

Integra SERVICE MANUAL

Sep., 2004

AV RECEIVER MODEL DTR-4.5

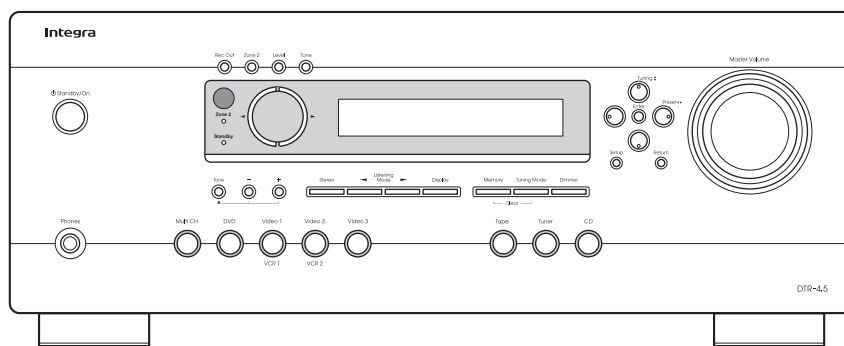

Black model

BMDD	120V AC, 60Hz
------	---------------

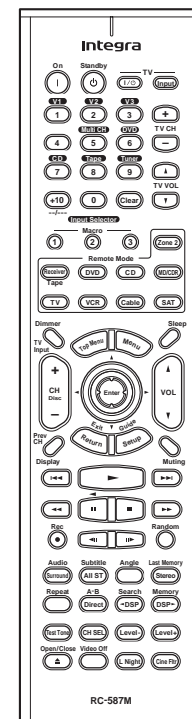

RC-587M

SAFETY-RELATED COMPONENT WARNING!!

THE MARK  FOUND ON SOME COMPONENT PARTS INDICATES THE CRITICAL FOR RISK OF FIRE AND ELECTRIC SHOCK.

WHEN REPLACING, BE SURE TO USE PARTS OF IDENTICAL DESIGNATION.

MAKE LEAKAGE-CURRENT OR RESISTANCE MEASUREMENTS TO DETERMINE THAT EXPOSED PARTS ARE ACCEPTABLY INSULATED FROM THE SUPPLY CIRCUIT BEFORE RETURNING THE APPLIANCE TO THE CUSTOMER.

SPECIFICATIONS

Amplifier Section

Power Output (2 channels driven):	85 W + 85 W (8Ω, 20Hz–20kHz, FTC) 120 W + 120 W (6Ω, 1kHz, DIN) 150 W + 150 W (6Ω, 1kHz, JEITA)
Dynamic Power	220 W + 220 W (3Ω, Front) 165 W + 165 W (4Ω, Front) 100 W + 100 W (8Ω, Front)
THD (Total Harmonic Distortion)	0.08 % (Power Rated)
Damping Factor	60 (Front, 1kHz, 8Ω)
Input Sensitivity and Impedance	200 mV / 47 kΩ (LINE)
Output Level and Impedance	200 mV / 470 Ω (REC OUT)
Frequency Response	10 Hz–100 kHz / +1 dB–3 dB (Direct mode)
Tone Control	±10 dB, 50 Hz (BASS) ±10 dB, 10 kHz (TREBLE)
SN Ratio	106 dB (LINE IHF-A)
Speaker Impedance	6Ω–8Ω

Video Section

Input Sensitivity/Output Level and Impedance	1 Vp-p / 75Ω (Component and S-Video Y) 0.7 Vp-p / 75Ω (Component Pb/Cb, Pr/Cr) 0.28 Vp-p / 75Ω (S-Video C) 1 Vp-p / 75Ω (Composite)
Component Video Frequency Response	5 Hz – 50 MHz

Tuner Section

FM

Tuning Frequency Range	87.5 MHz– 107.9 MHz
Usable Sensitivity	Stereo: 17.2 dBf 2 μV (75 Ω IHF) Mono: 11.2 dBf 1 μV (75 Ω IHF)
S/N Ratio	Stereo: 70 dB (IHF-A) Mono: 76 dB (IHF-A)
THD	Stereo: 0.3 % (1kHz) Mono: 0.2 % (1kHz)
Frequency Response	30 Hz–15 kHz / ±1 dB
Stereo Separation	45 dB (1kHz)

AM

Tuning Frequency Range	530 kHz–1700 kHz
Usable Sensitivity	30 μV
S/N Ratio	40 dB
THD	0.70%

General

Power Supply	AC 120 V, 60 Hz
Power Consumption	5.7A
Stand-by Power Consumption	1.0 W
Dimensions (W x H x D)	17-1/8" W x 6-7/8" H x 16-7/8" D inches
Weight	13.4 kg 27.6 lbs

Video Inputs

Component Video Input	1,2,3
S-Video Compatible Jack Input	DVD, VIDEO1, VIDEO2, VIDEO3
A/V Input	DVD, VIDEO1, VIDEO2, VIDEO3

Video Outputs

Component Video Output	OUT
S-Video Compatible Jack Output	MONITOR OUT, VIDEO1, VIDEO2
A/V Output	MONITOR OUT, VIDEO1, VIDEO2

Audio Inputs

Digital Inputs	Optical : 2 Coaxial : 2
Analog Inputs	DVD (MULTICHANNEL), VIDEO1, VIDEO2, VIDEO3, TAPE, CD
Multichannel Inputs	6

Audio Outputs

Digital Output	1 (Optical)
Analog Outputs	TAPE, VIDEO1, VIDEO2
Subwoofer Pre Output	1
Speaker Outputs	7
Phones	1

Other Jacks

RS-232 Control	1
IR Input/Output	1
12V Trigger Out	3

Specifications and features are subject to change without notice.

SERVICE PROCEDURES

1. Replacing the fuses



This symbol located near the fuses indicates that the fuse used is fast operating type. For continued protection against fire hazard, replace with same type fuse. For fuse rating refer to the marking adjacent to the symbol.



Ce symbole indique que le fusible utilise est a rapide. Pour une protection permanente, n'utiliser que fusibles de meme type. Ce dernier est la qu le present symbol est appse.

CIRCUIT NO.	PART NO.	DESCRIPTION
F6901,F6902	252301 or 252196	12A-TUL-250V or 12A-UL/T-314,Fuse
F901	252198	8A-UL,Fuse
F903	252164 or 252258	5A-UL/T-237 or 5A-T/UL-ST2,Fuse
F9501	252160 or 252254	2.5A-UL/T-237 or 2.5A-T/UL-ST2,Fuse

2. To initialize the unit

This device employs a microprocessor to perform various functions and operations. If interference generated by an external power supply, radio wave, or other electrical source results in accident which causes the specified operations and functions to operate abnormally.

To perform a result, please follow the procedure below.

1. Press and hold down the VIDEO-1 button, then press the STANDBY/ON button.
2. After "CLEAR" is displayed, the preset memory and each mode stored in the memory, such as surround, are initialized and will return to the factory setting.
3. Unplug the power supply cord.

3. Safety-check out

(U.S.A. model only)

After correcting the original service problem, perform the following safety check before releasing the set to the customer.

Leakage Current Check

Measure leakage current to a known earth ground(water pipe, conduit, etc.) by connecting a leakage current tester between the earth ground and exposed metal parts of the appliance (input/output terminals, screwheads,metal overlays, etc.).

Plug the power supply cord directly into a 120V AC 60 Hz outlet and turn Standby switch on. Any current measured must not exceed 0.5mA.

A

B

C

D

E

EXPLODED VIEW

1

2

3

4

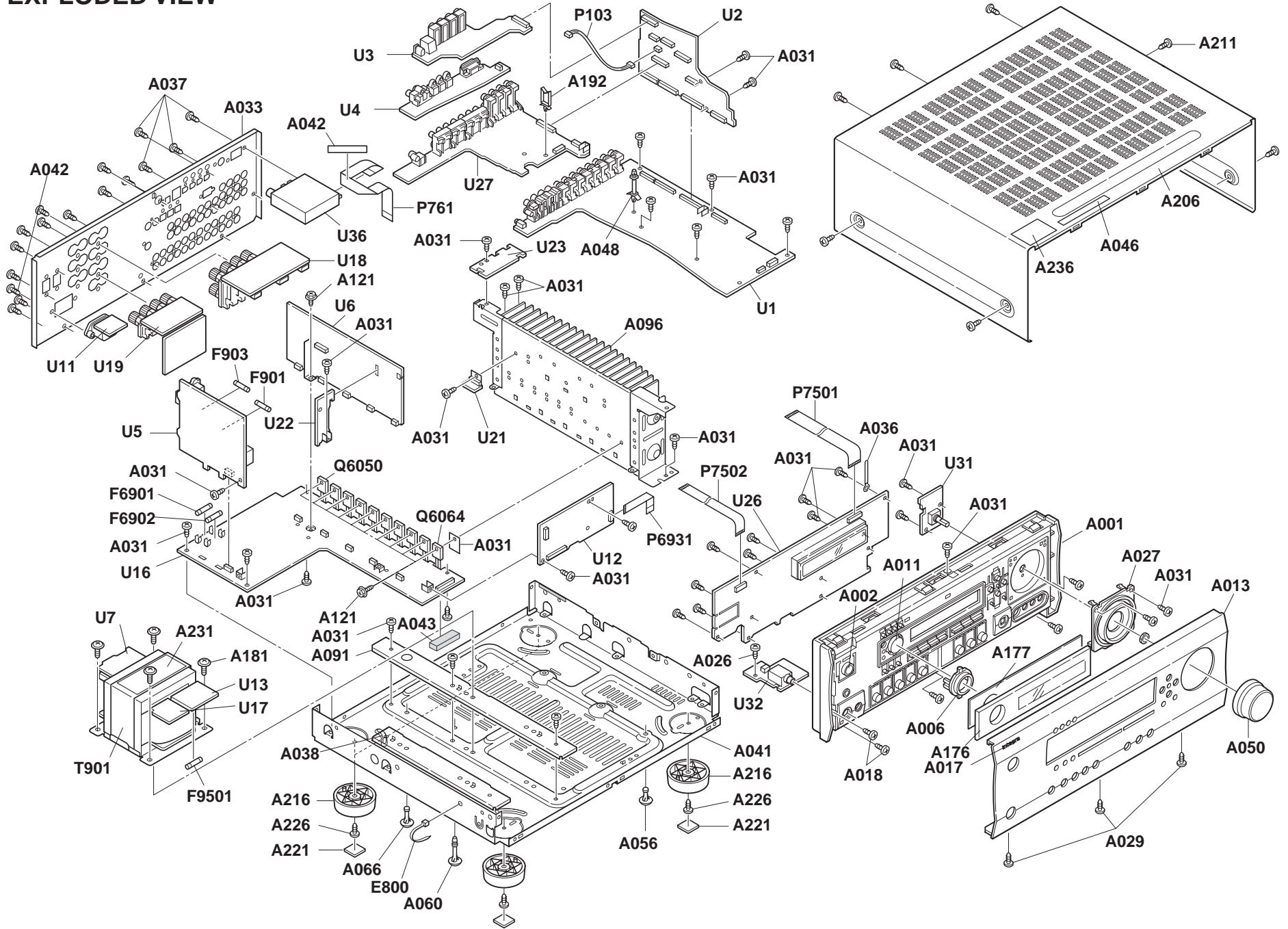

A B C D
BLCOK DIAGRAM Amplifier section

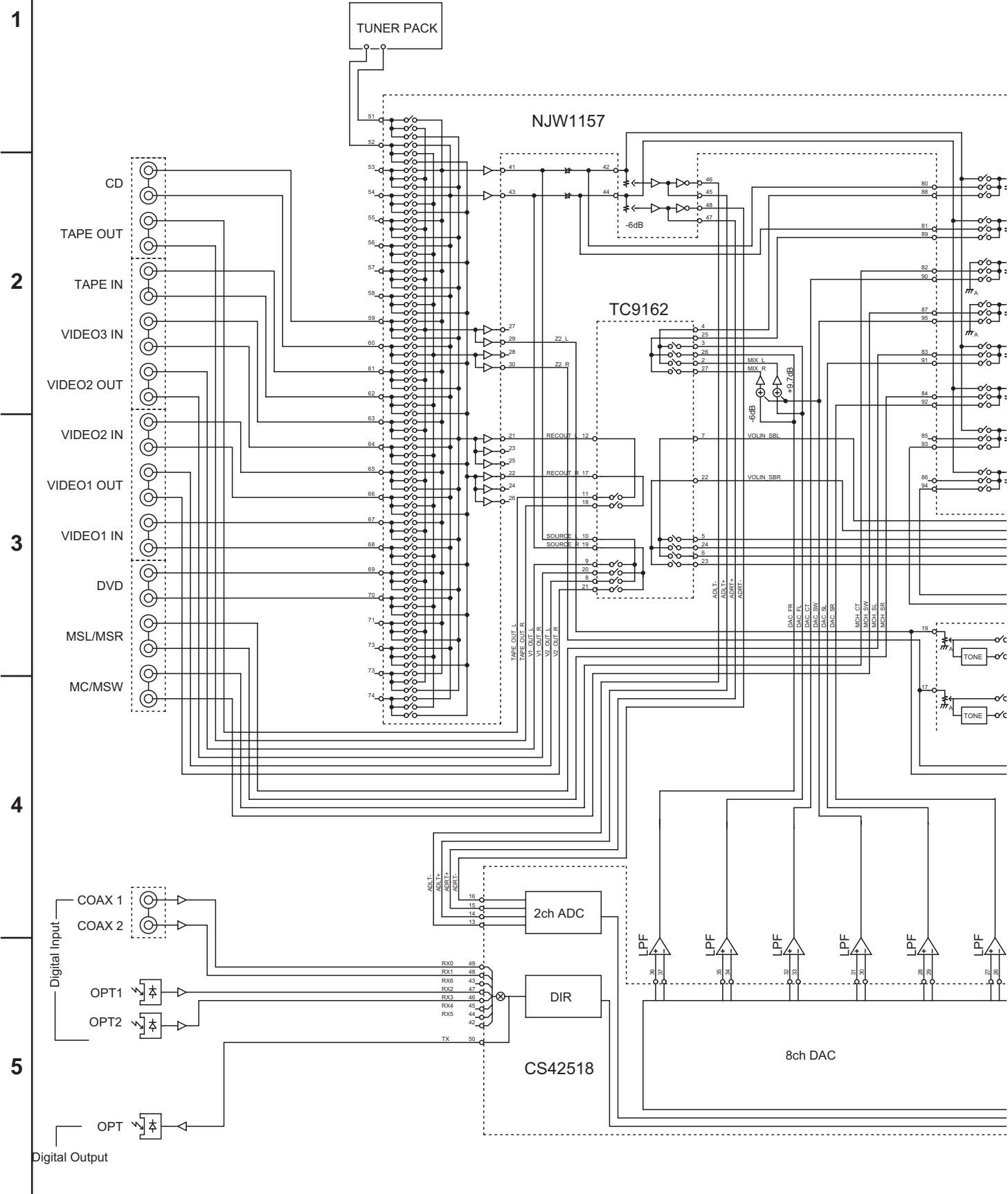

1

2

3

4

5

CD
TAPE OUT
TAPE IN
VIDEO3 IN
VIDEO2 OUT
VIDEO2 IN
VIDEO1 OUT
VIDEO1 IN
DVD
MSL/MSR
MC/MSW

Digital Input
COAX 1
COAX 2
OPT1
OPT2
OPT
Digital Output

TUNER PACK

NJW1157

TC9162

2ch ADC

DIR

CS42518

8ch DAC

tone

tone

A B C D

BLCOK DIAGRAM Amplifier section

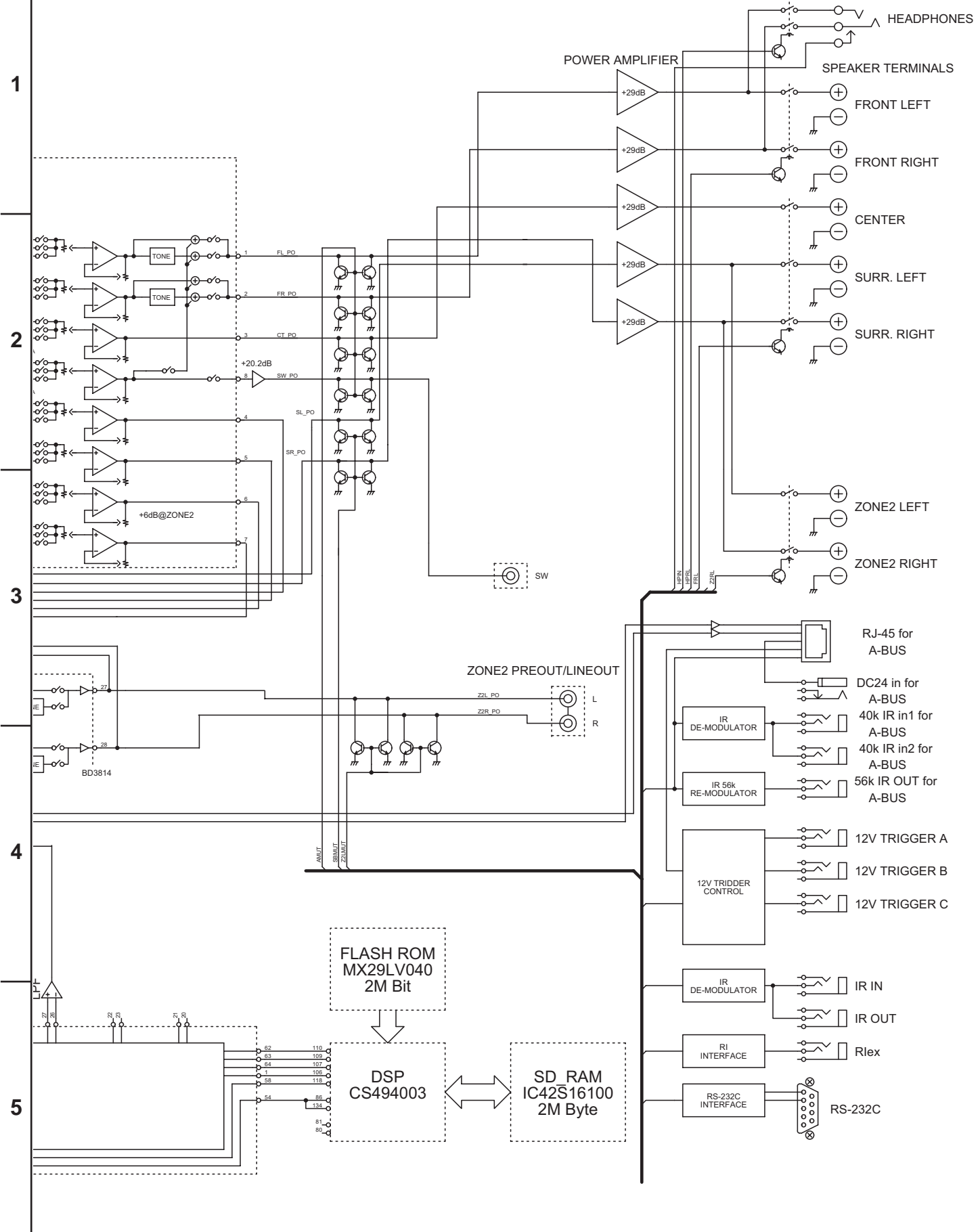

A

B

C

D

BLOCK DIAGRAM Video section

1

COMPONENT VIDEO INPUT

Y1

CB1

CR1

Y2

CB2

CR2

Y3

CB3

CR3

2

3

COMPOSITE VIDEO INPUT

DVD

VIDEO1

VIDEO2

VIDEO3

NJM2595

OSD
LC74763-9836

Y/C Mix
MM1512

4

5

S VIDEO INPUT

DVD

VIDEO1

VIDEO2

VIDEO3

NJM2595

NJM2595

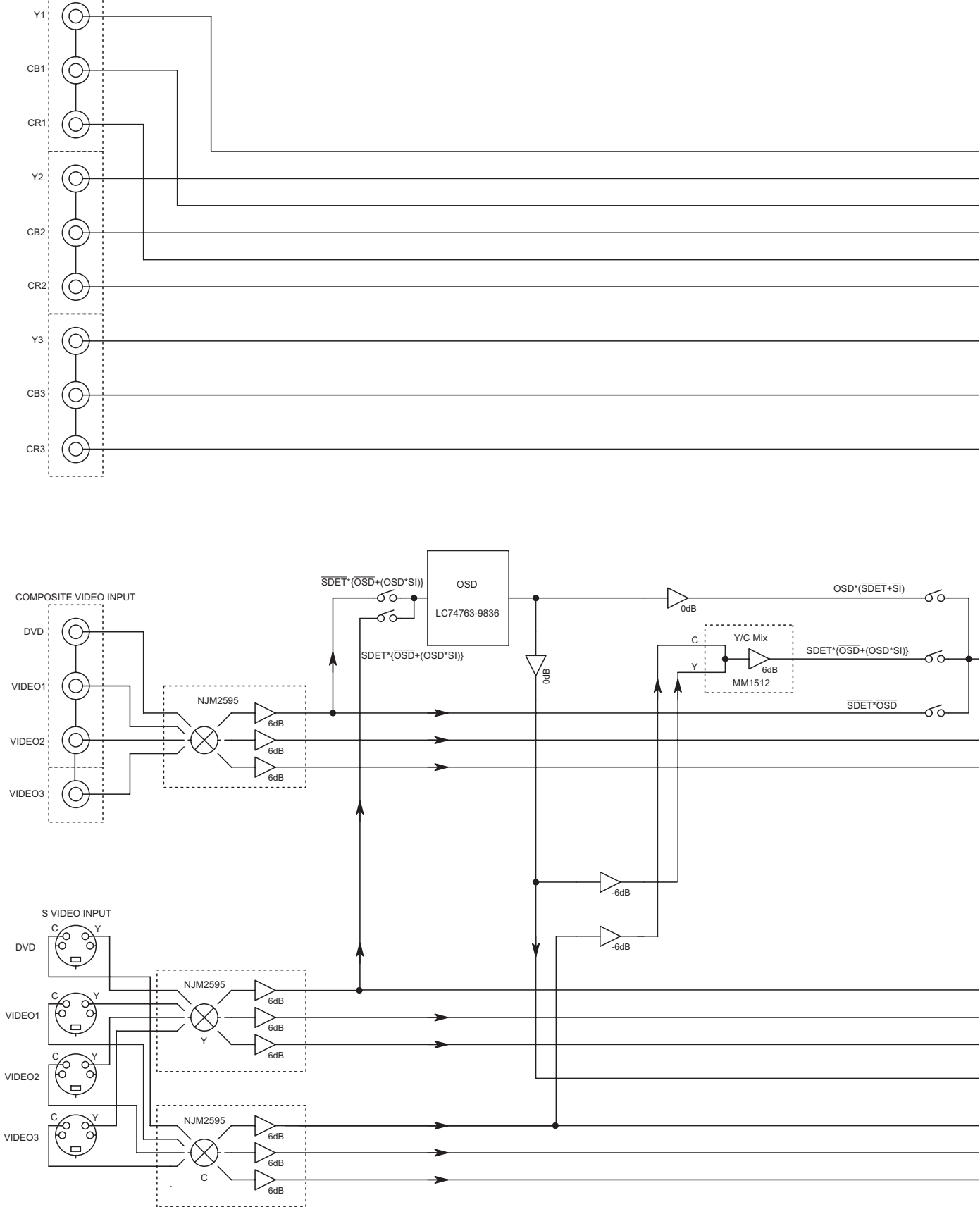

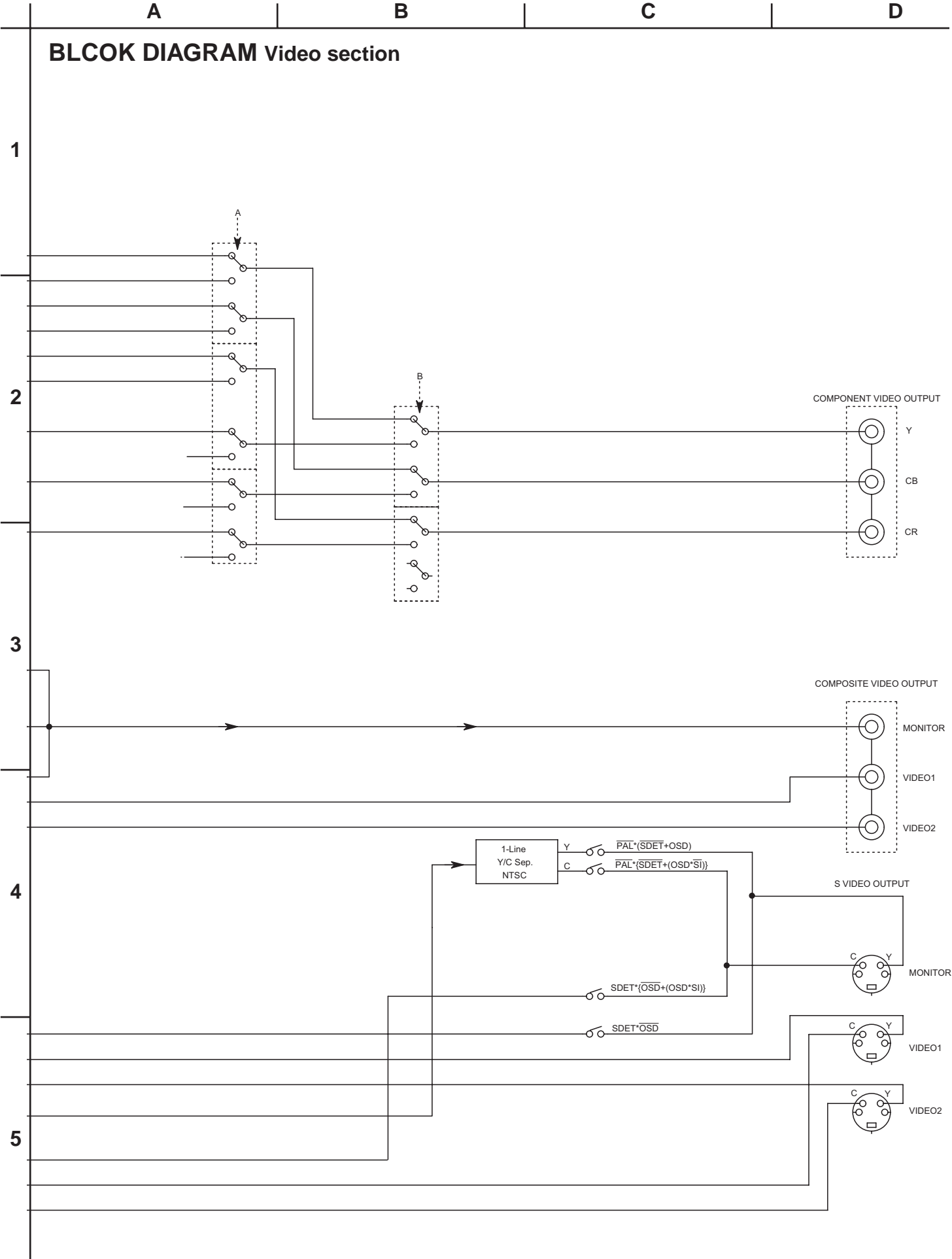

SCHEMATIC DIAGRAM 1 Preamplifier section

TO NAPS-8389 (SCH. 6)

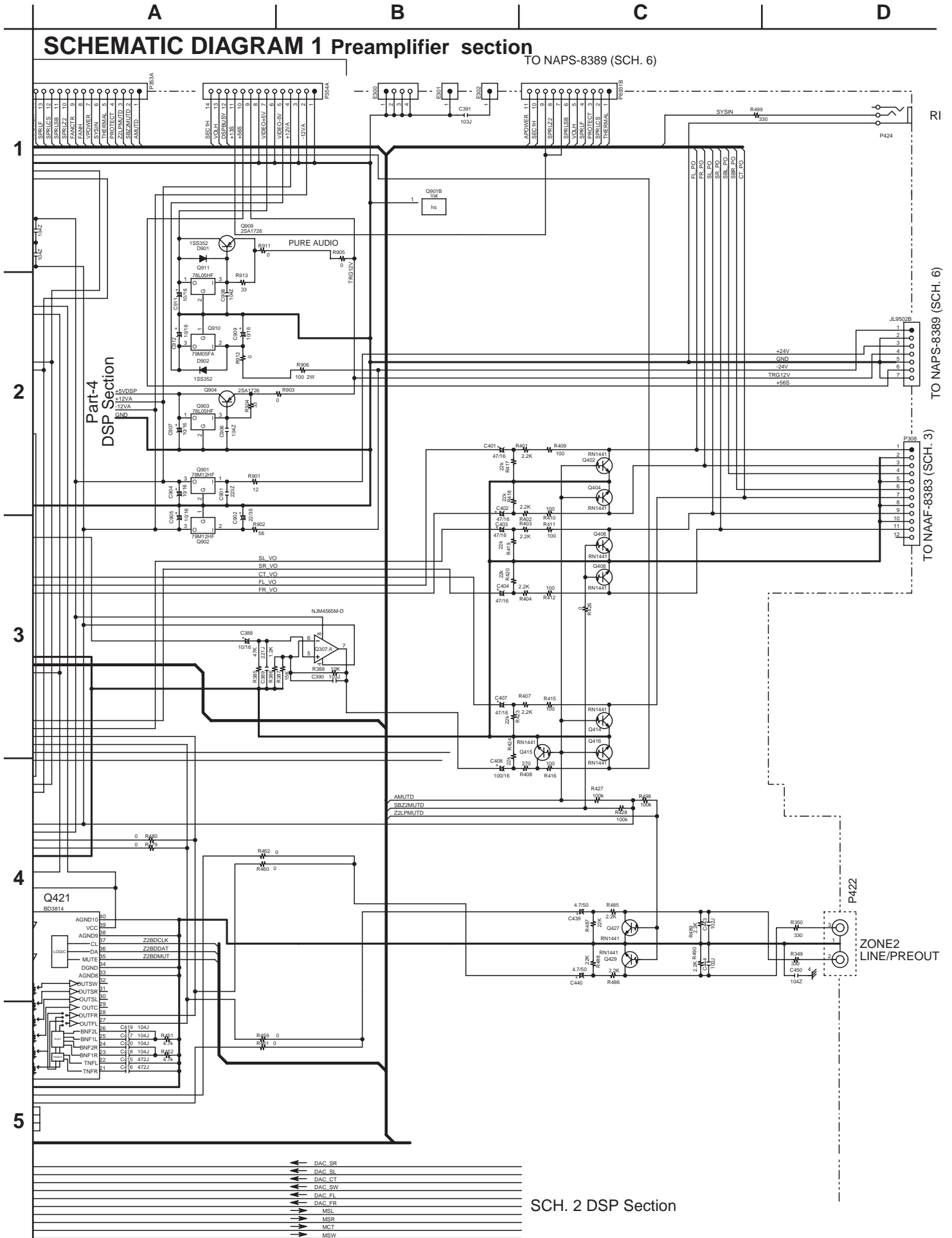

SCH. 2 DSP Section

- ↑ DAC_SR
- ↑ DAC_SL
- ↑ DAC_CT
- ↑ DAC_SW
- ↑ DAC_FL
- ↑ DAC_FR
- ↑ MSL
- ↑ MSR
- ↑ MCT
- ↑ MSW

A B C D
SCHEMATIC DIAGRAM 2 DSP section

1 NAAR-8365-1(2)

U1

1

2

3

4

5

SCH. 1
ASP Section

ADLT+
ADLT-
ADRT+
ADRT-
DAC_FL
DAC_FR
DAC_CT
DAC_SW
DAC_SL
DAC_SR

R157 0
R158 0
R159 0
R160 0
R161 0
R162 0
R163 0
R164 0
R165 0

FL FL
FL FR
FL CT
FL SW
FL SL
FL SR

+12VA
-12VA

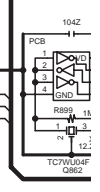
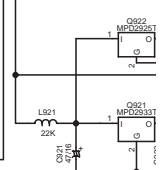
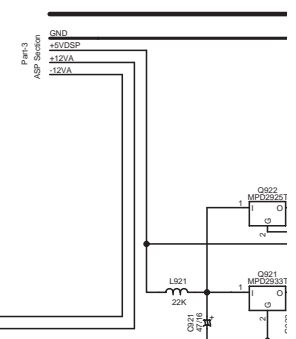
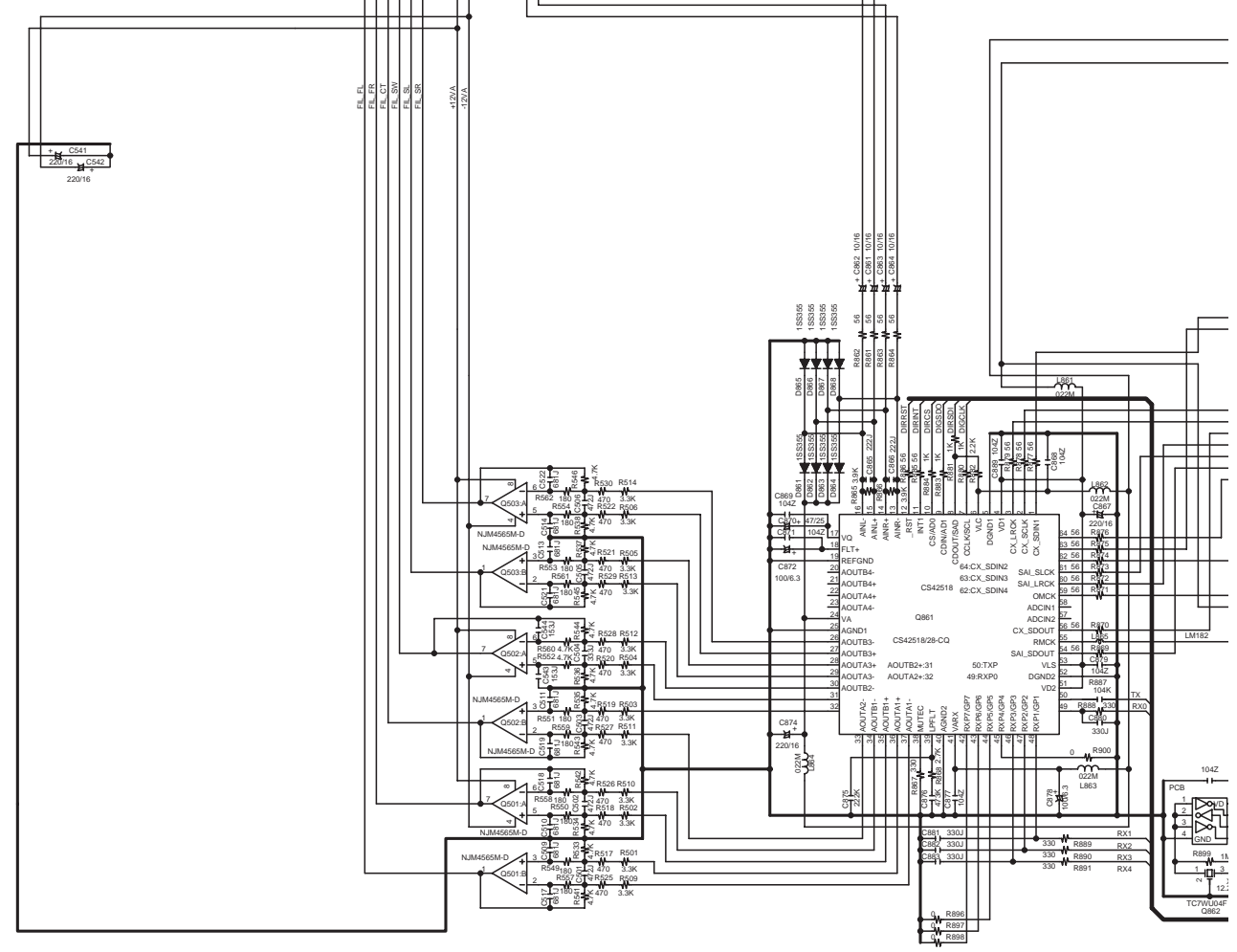
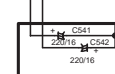

A B C D

SCHEMATIC DIAGRAM 3

Driver section

NAAF-8383

U6

1

2

3

4

5

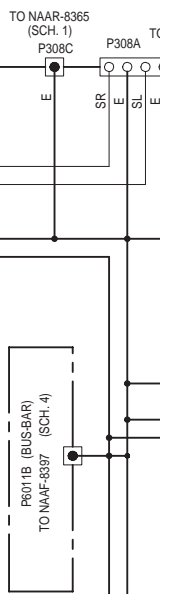
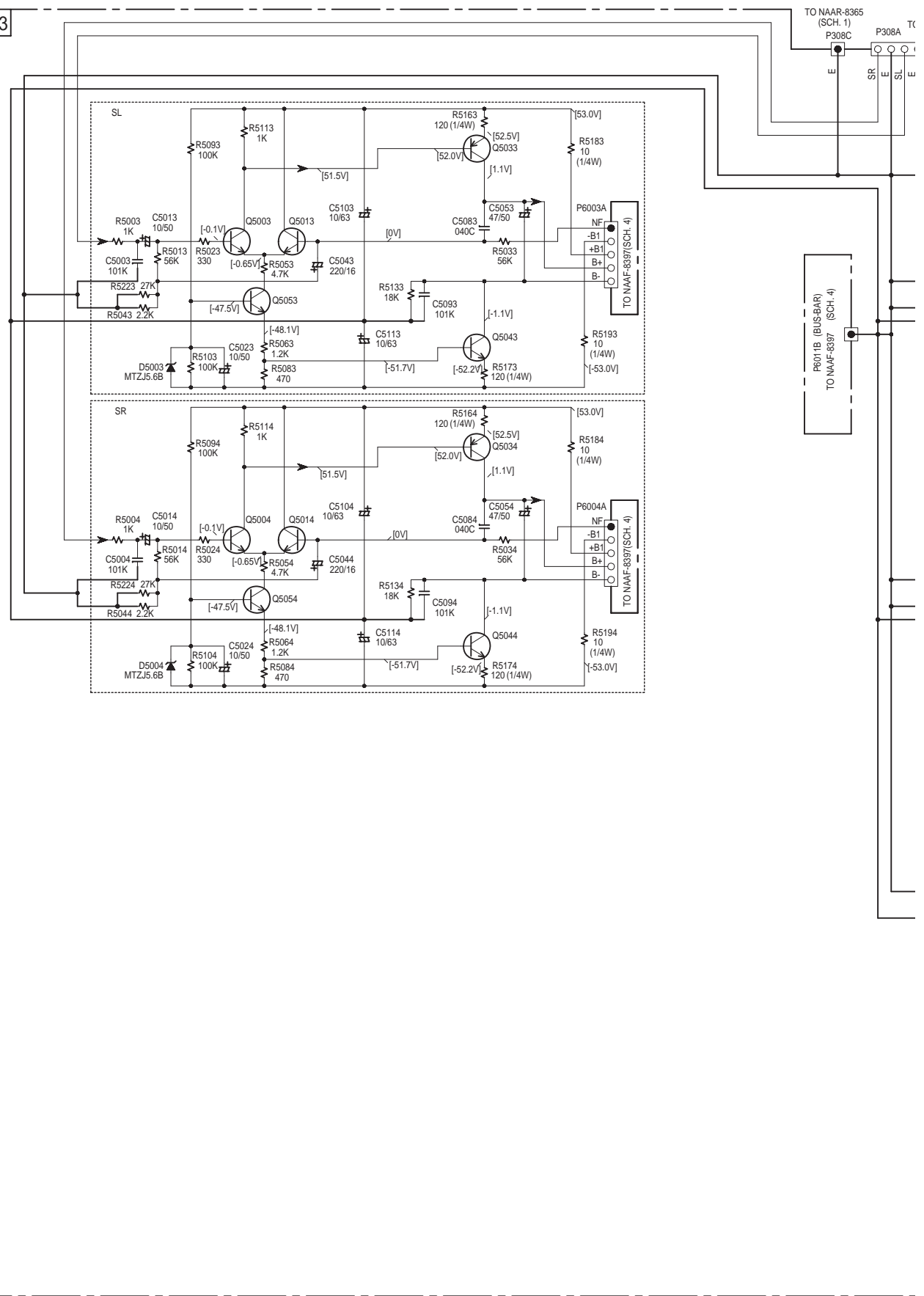

A B C D

SCHEMATIC DIAGRAM 3

Driver section

1

2

3

4

5

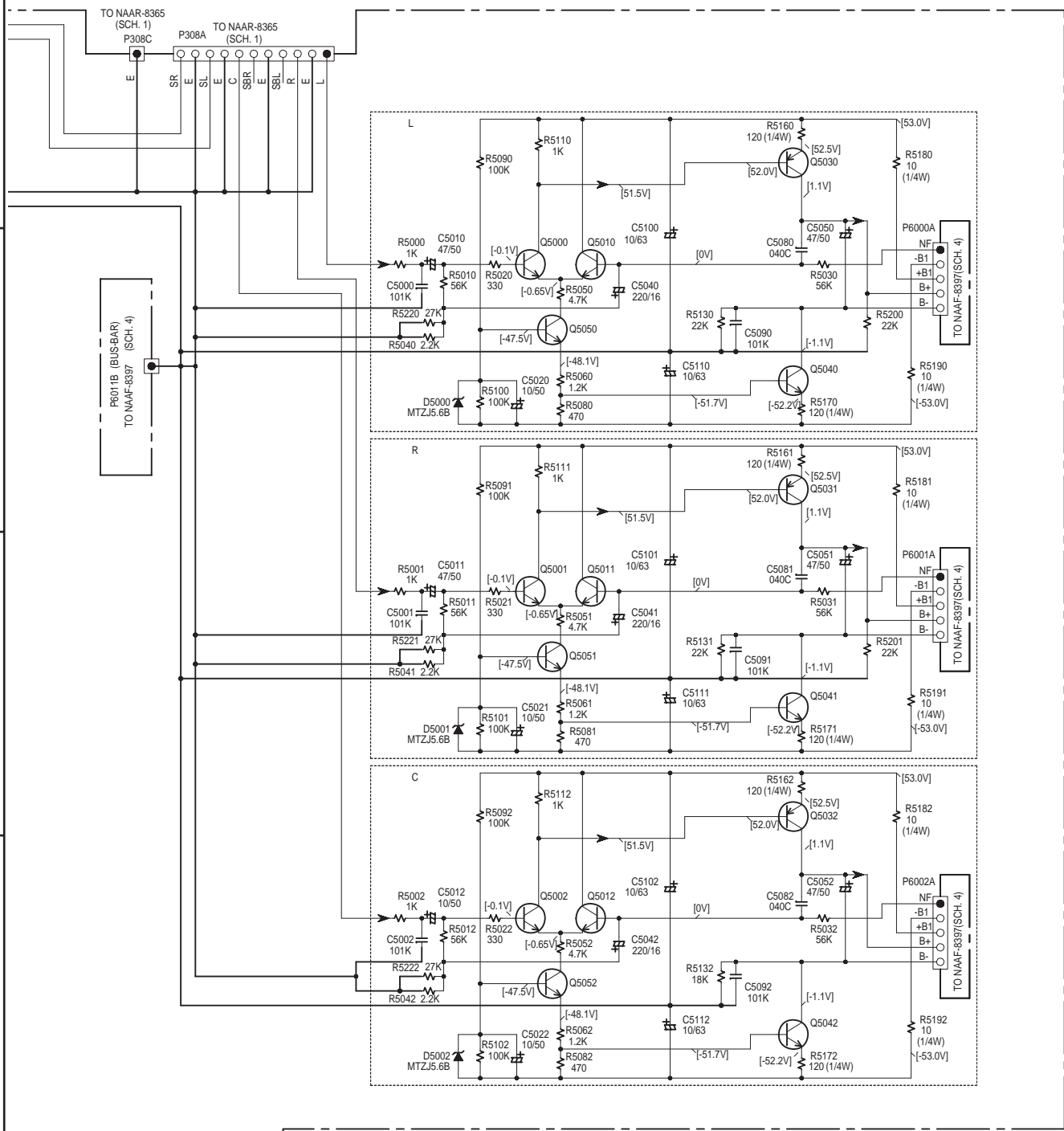

SEMICONDUCTORS

NO.	X=0.12 (0L, 1R, 2C)	X=3.4 (3SL, 4SR)
Q500X, Q501X	2SC1775A-E.F OR 2SC1845-E	KTC3200-BL OR 2SC1775A-E.F OR 2SC1845-E
Q503X	2SA1360-Y.O	KTA1024-Y.O OR 2SA949-Y.O
Q504X	2SC3423-Y.O	KTC3206-Y.O OR 2SC2229-Y.O
Q505X	KTC3200-BL,GR OR 2SC1775A-E.F OR 2SC1845-E.F	KTC3200-BL,GR OR 2SC1775A-E.F OR 2SC1845-E.F

SCHEMATIC DIAGRAM 4

Power amplifier section

NAAF-8397

U16

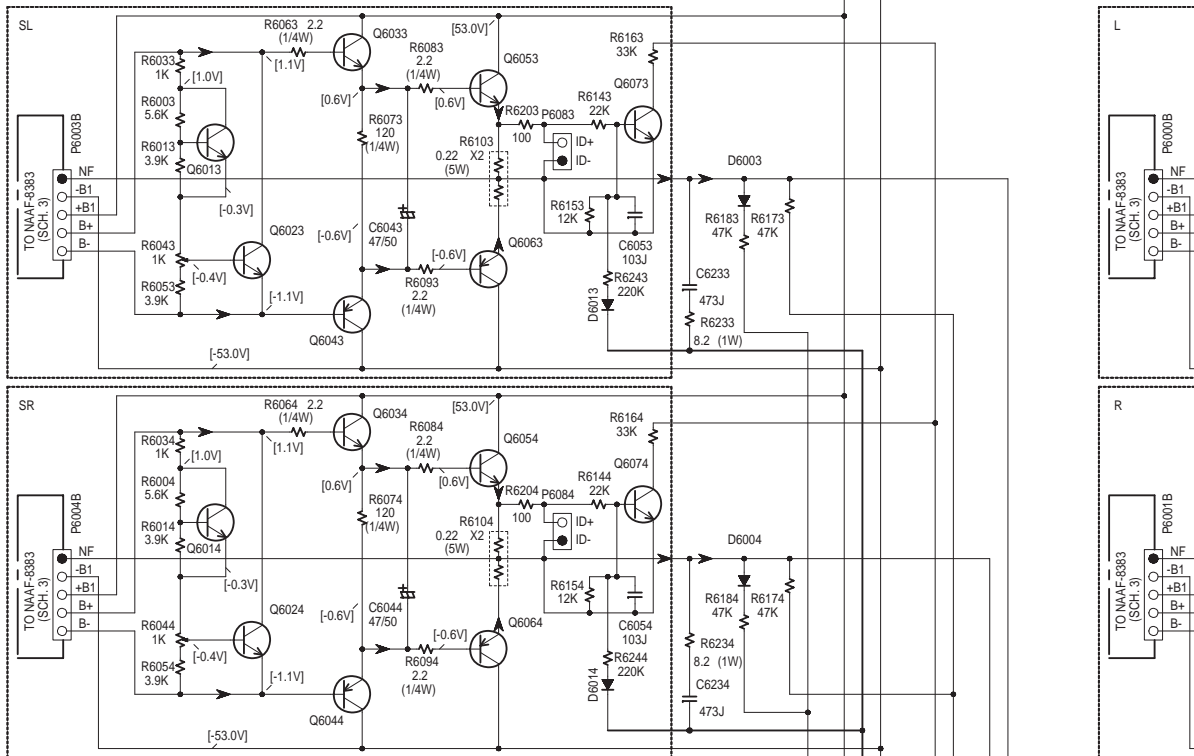

SEMICONDUCTORS

NO.	PARTS
Q6010-6014	2SC1740S-R,S
Q6020-6024	2SC1740S-R,S
Q6601-6604,Q6901	KTC3199-GR OR 2SC1740S-R,S OR 2SC2458-GR
Q6701,6702	KTC3200-BL GR OR 2SC1775A-E,F OR 2SC1845-E,F
Q6703	KTA1268-BL GR OR 2SA992-E,F
Q6303,6304	KTA1267-GR OR 2SA933S-R,S
Q6501	2SC1845-GR
Q6070-6074	KTC3200-BL GR OR 2SC1775A-E,F OR 2SC1845-E,F

SEMICONDUCTORS

NO.	CH-L(0) / R(1) / C(2)	SL(3) / SR(4)
Q6030-36	2SC5171	2SC5171 OR KTD2061-Y
Q6040-44	2SA1930	2SA1930 OR KTB1369-Y
Q6050-54	2SC5242-R,O	2SC5242-R,O OR MN130S-O,Y,P
Q6060-64	2SA1962-R,O	2SA1962-R,O OR MP130S-O,Y,P

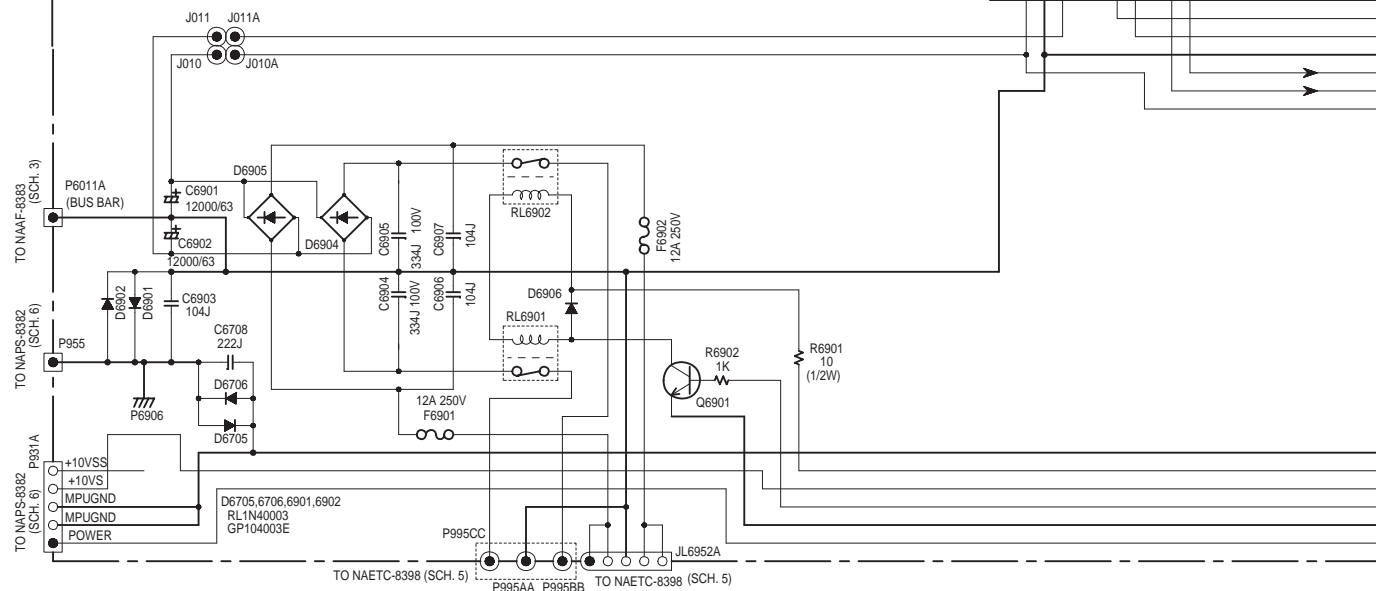

1

2

3

4

5

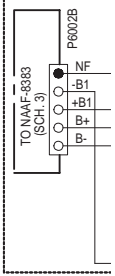
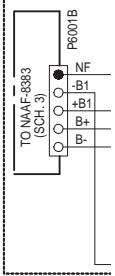
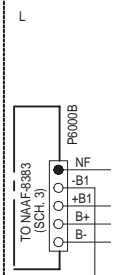

TO NAAF-8383 (SCH. 3)

TO NAPS-8382 (SCH. 6)

TO NAPS-8382 (SCH. 6)

TO NAPS-8382 (SCH. 6)

TO NAETC-8398 (SCH. 5) TO NAETC-8398 (SCH. 5)

SCHEMATIC DIAGRAM 4

Power amplifier section

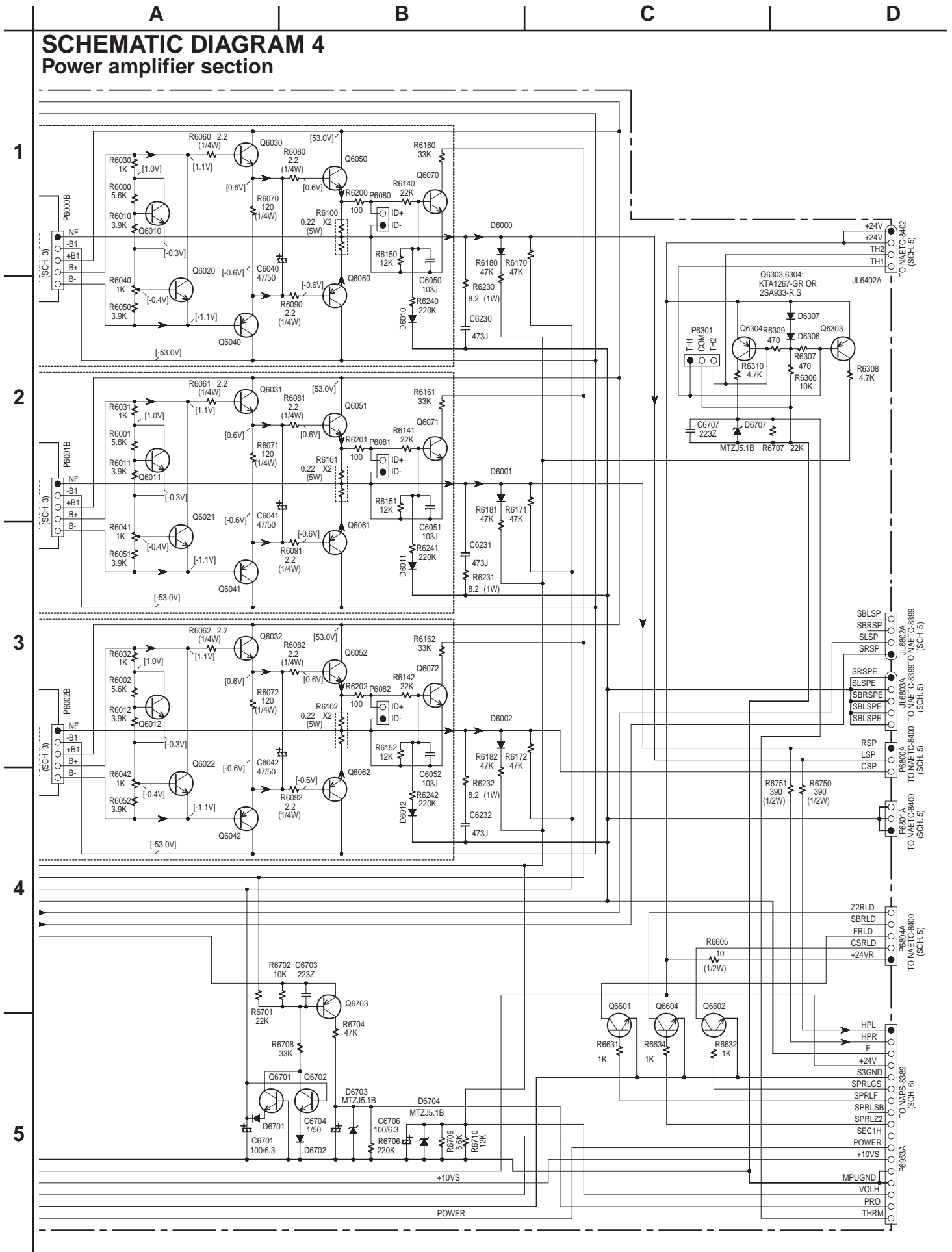

A

B

C

D

SCHEMATIC DIAGRAM 5

Speaker terminal section

1

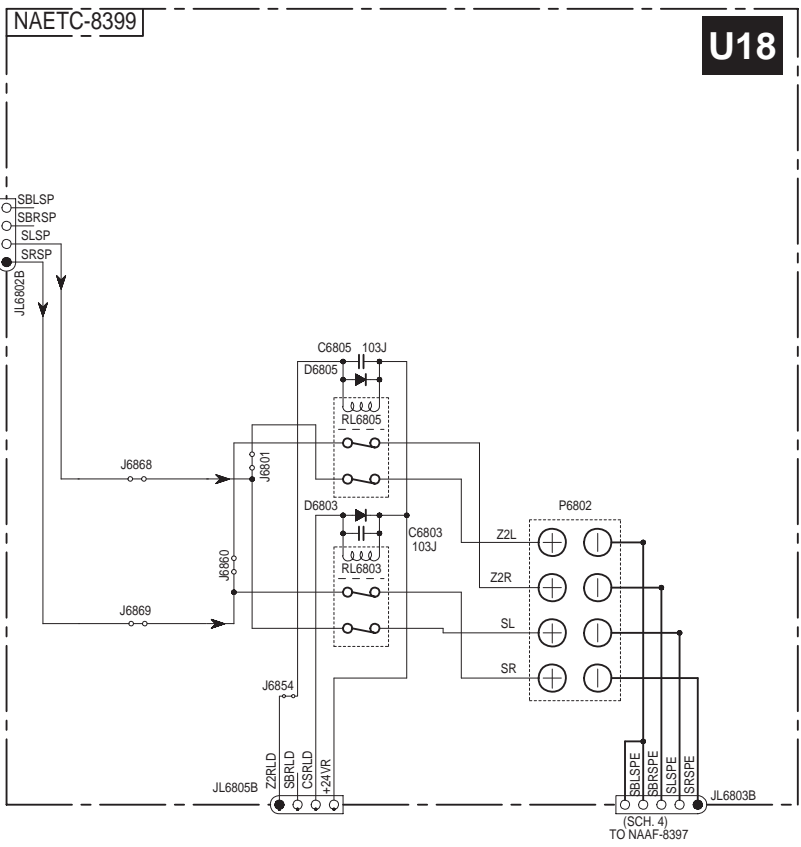

2

3

U21

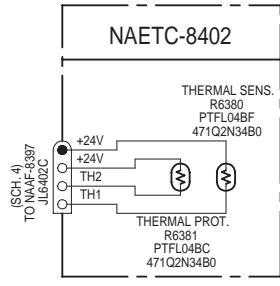

4

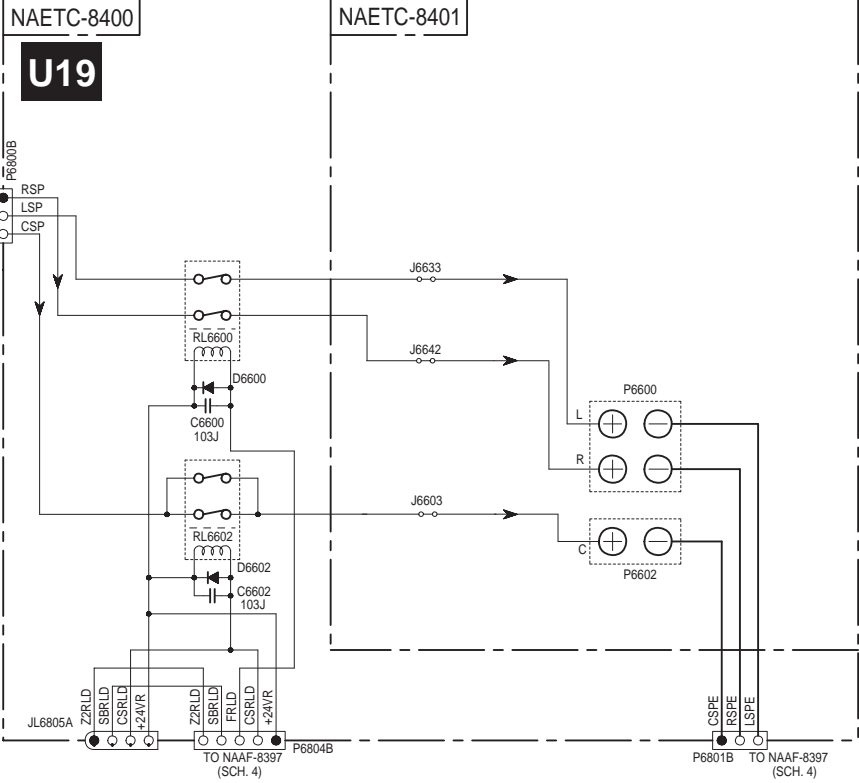

5

SCHEMATIC DIAGRAM 7 Display section

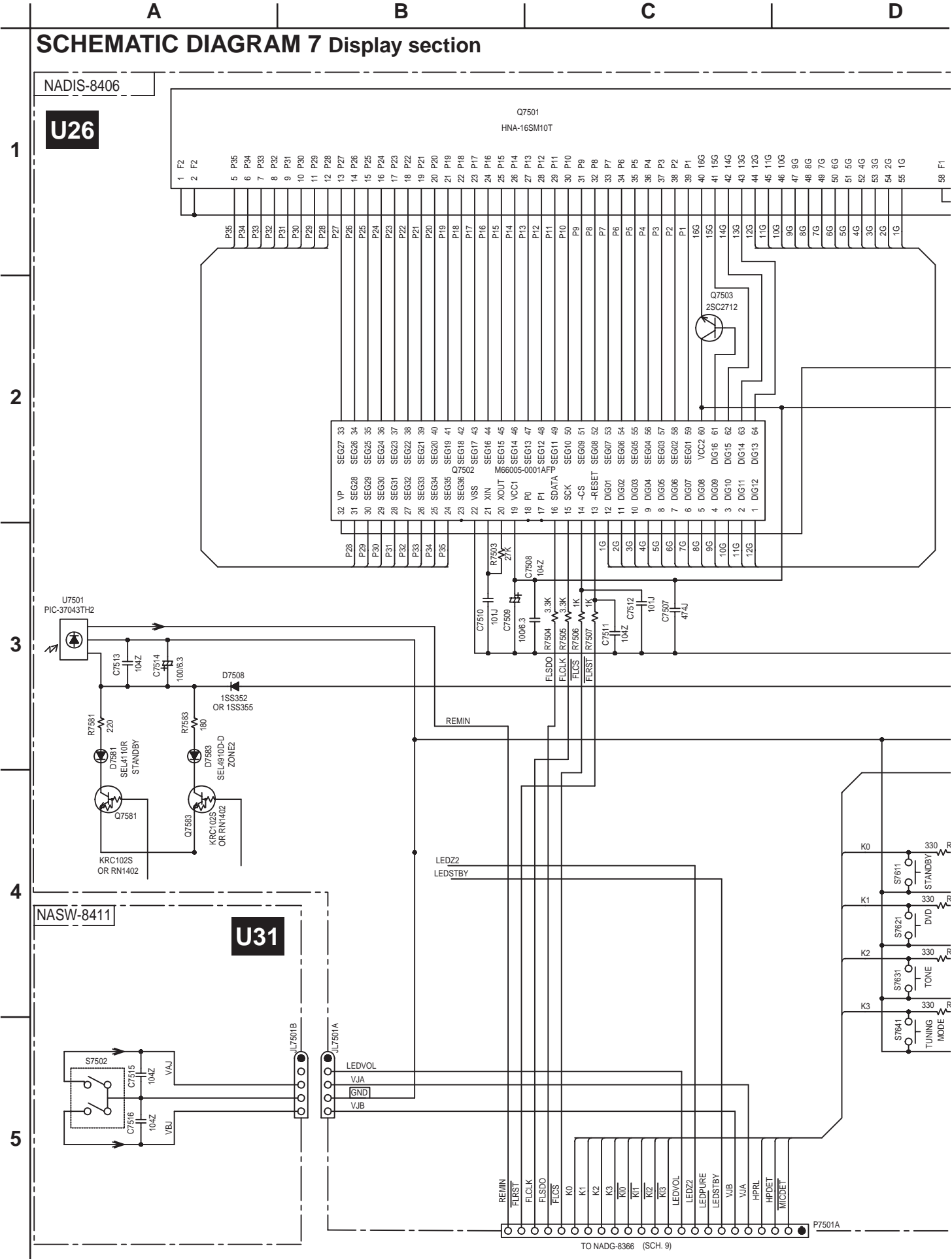

SCHEMATIC DIAGRAM 7 Display section

1

2

3

4

5

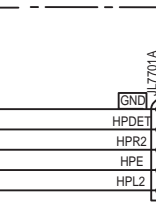
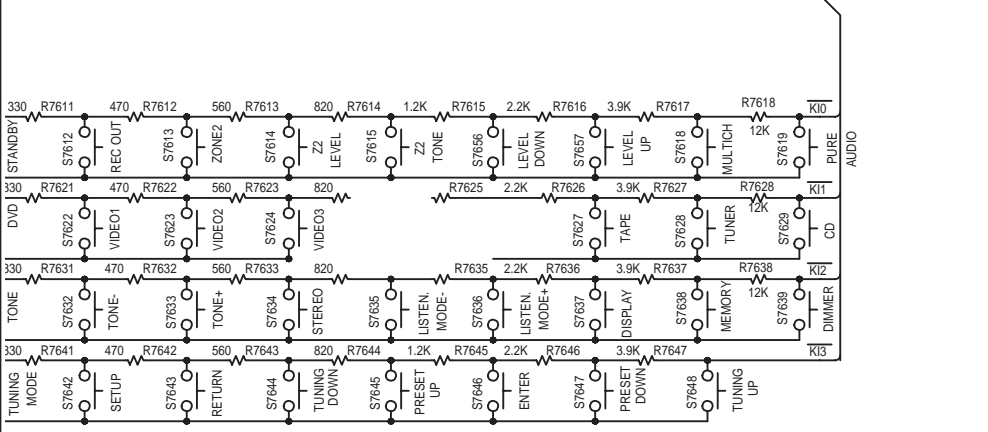
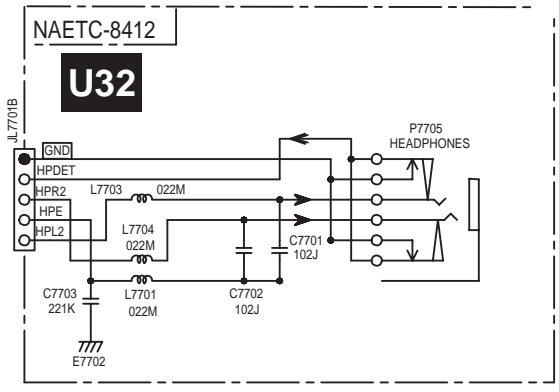
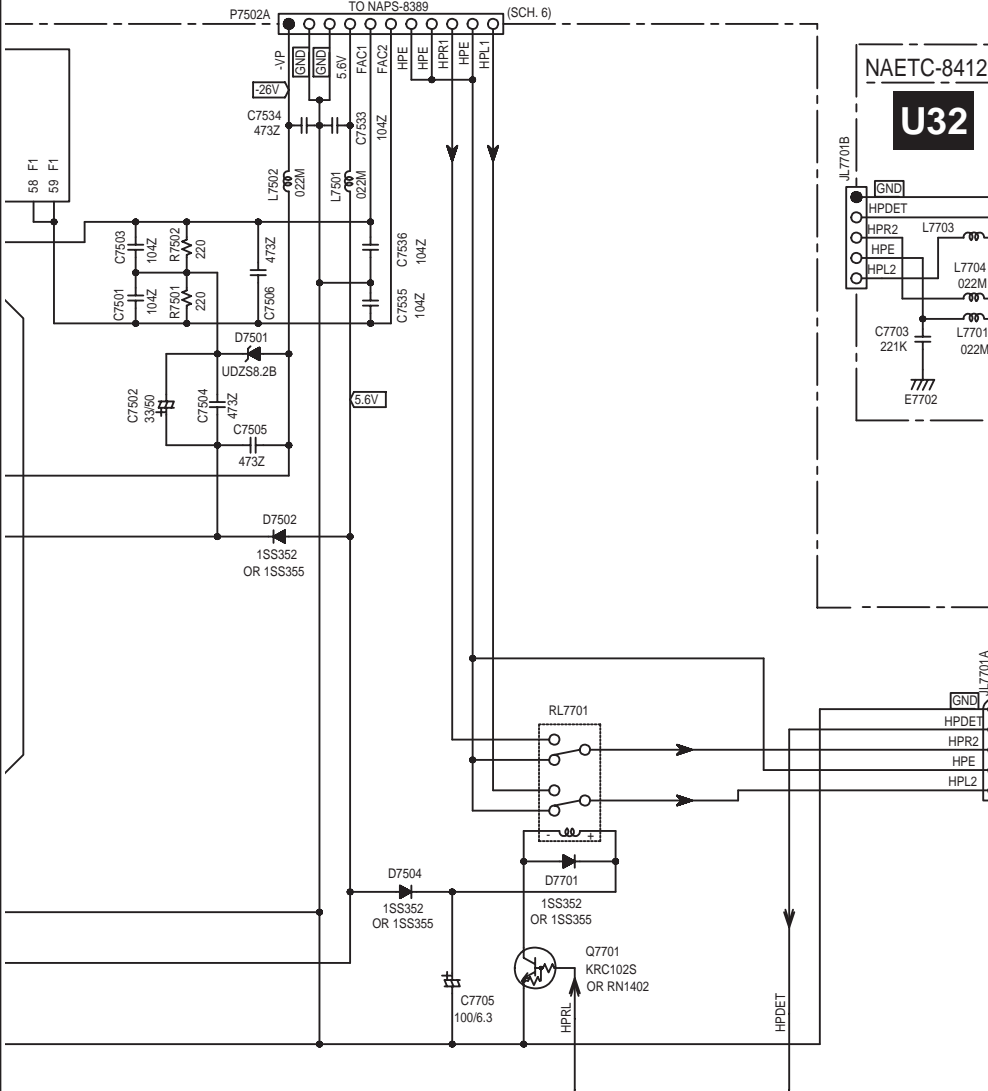

A

B

C

D

SCHEMATIC DIAGRAM 8 Video section

1

2

3

4

5

U27

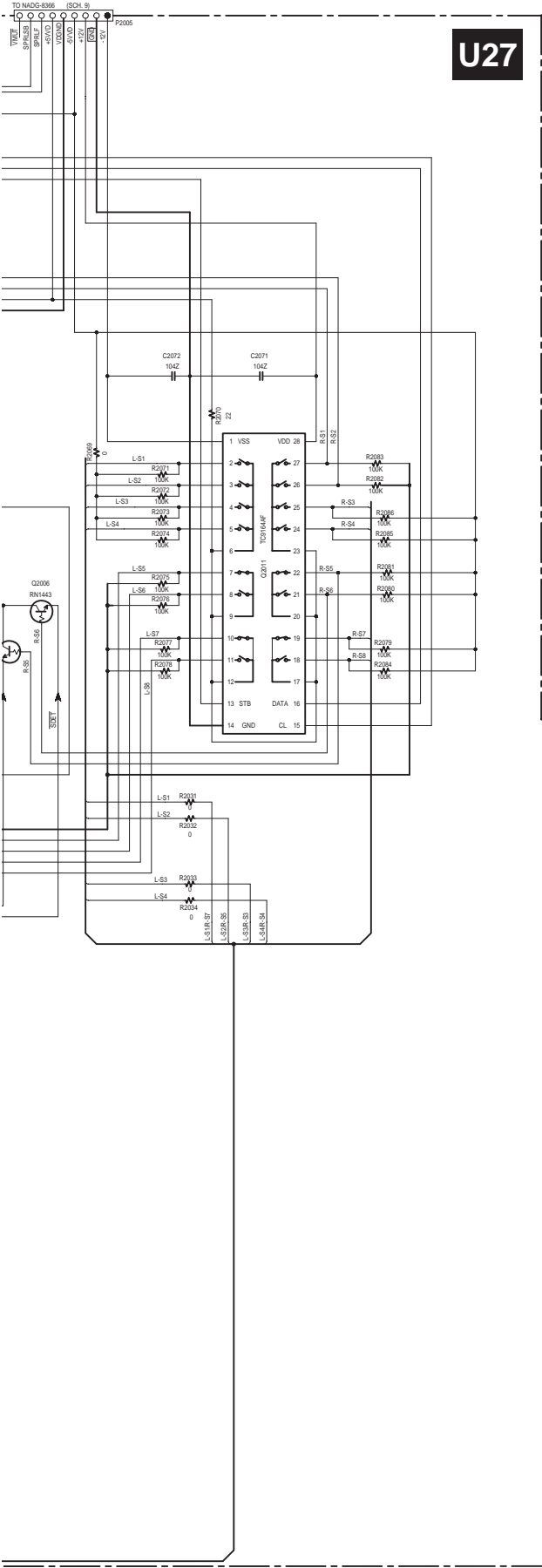

A B C D
SCHEMATIC DIAGRAM 9 Microprocessor section

U2
NADG-8366

1

2

3

4

5

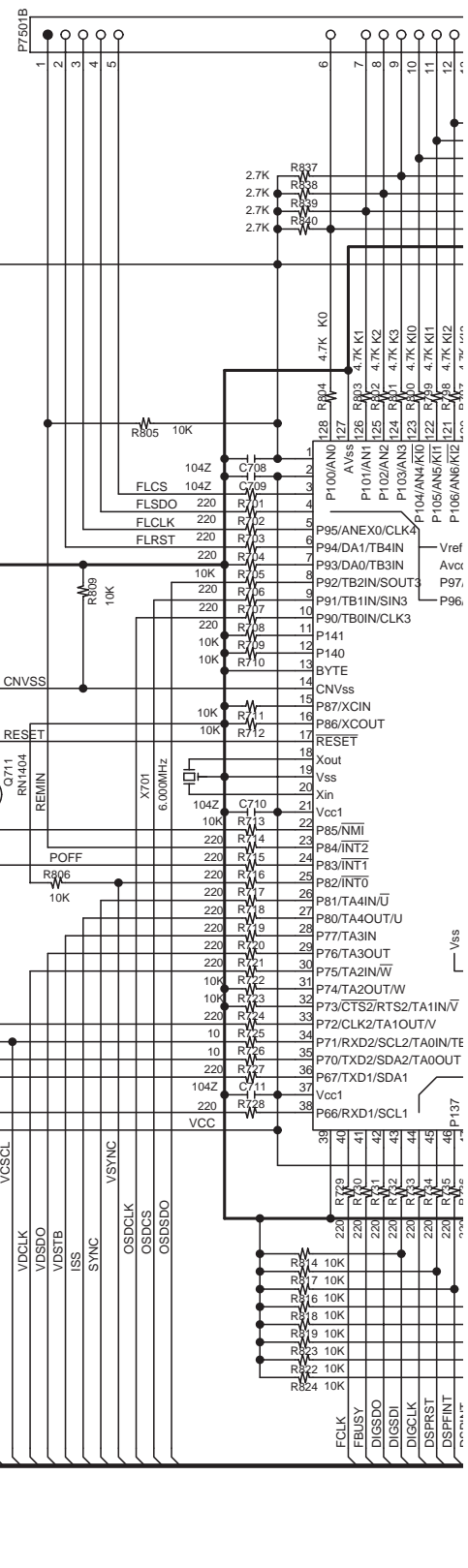
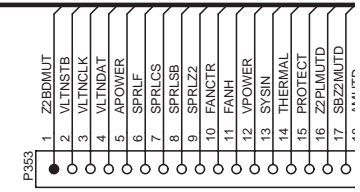
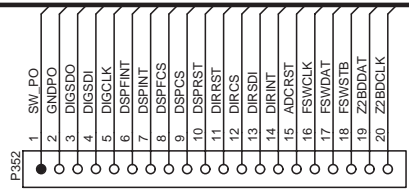
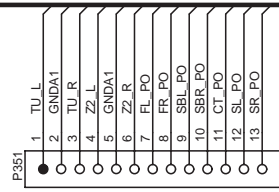
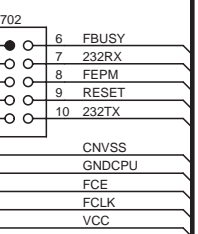
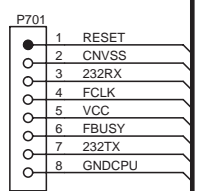
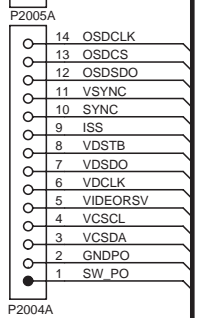
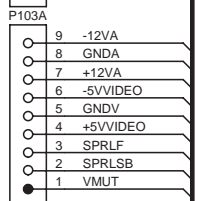
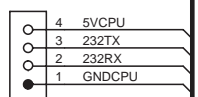
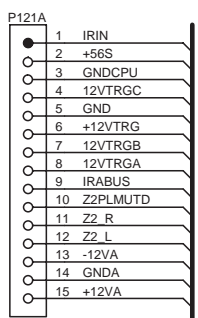

SCHEMATIC DIAGRAM 9 Microprocessor section

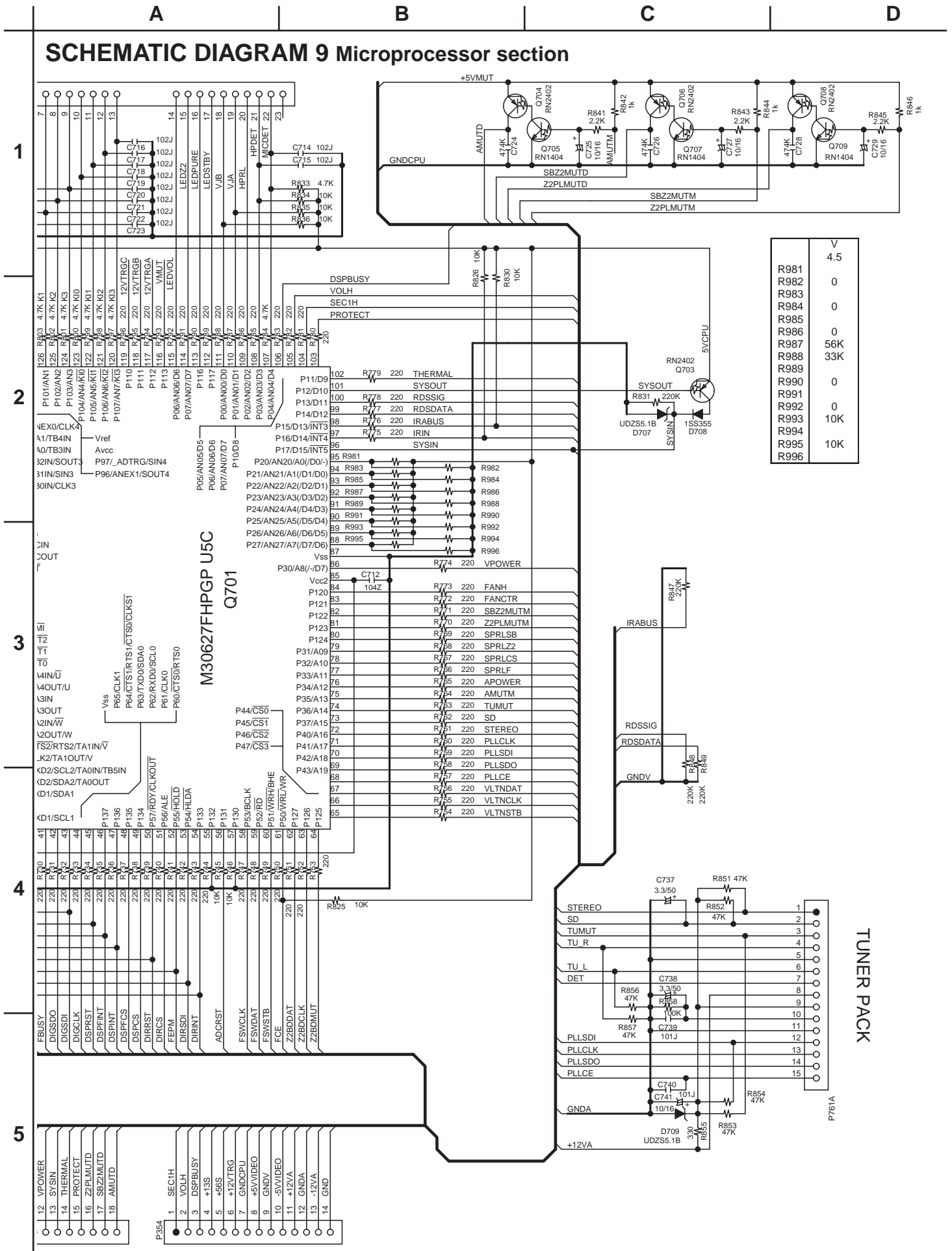

Resistor	Value
R981	4.5
R982	0
R983	0
R984	0
R985	0
R986	0
R987	56K
R988	33K
R989	0
R990	0
R991	0
R992	0
R993	10K
R994	0
R995	10K
R996	0

TUNER PACK

P761A

A

B

C

D

SCHEMATIC DIAGRAM 10

I/O terminal sections

1

2

3

4

5

NADG-8368

U4

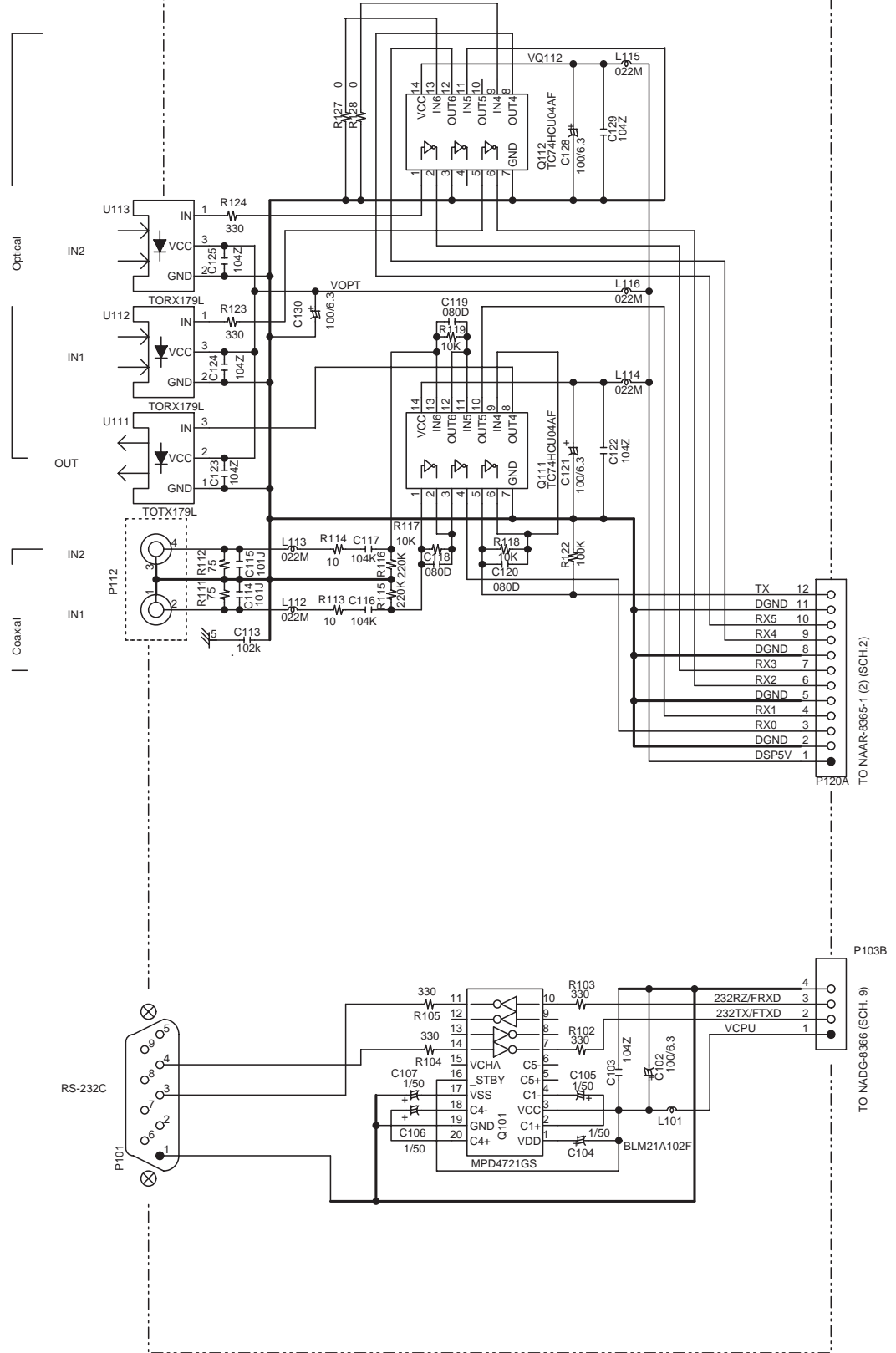

A

B

C

D

SCHEMATIC DIAGRAM 10

I/O terminal sections

1

NAETC-8367

U3

2

3

4

5

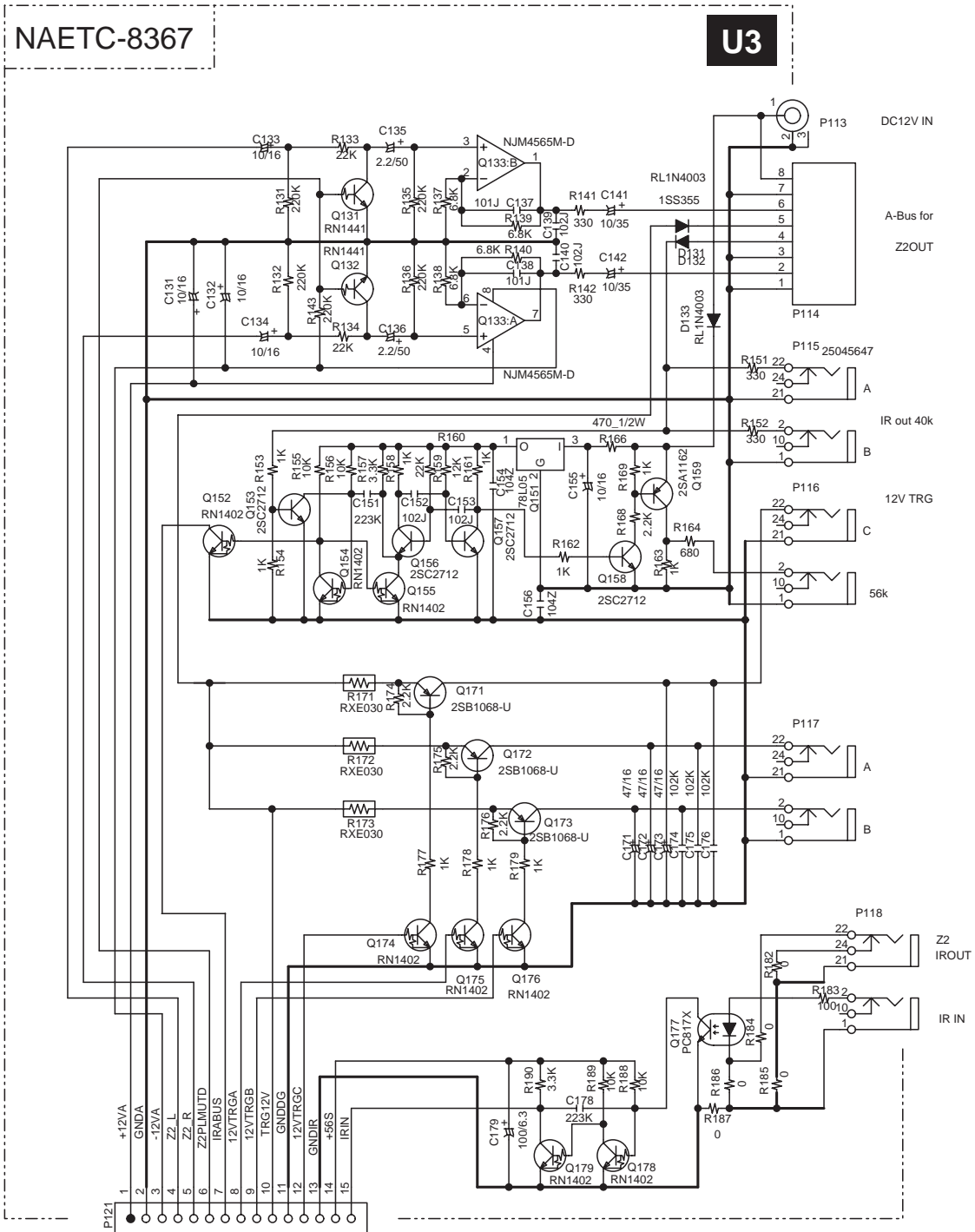

TO NADG-8366 (SCH. 9)

A B C D

WIRING VIEW

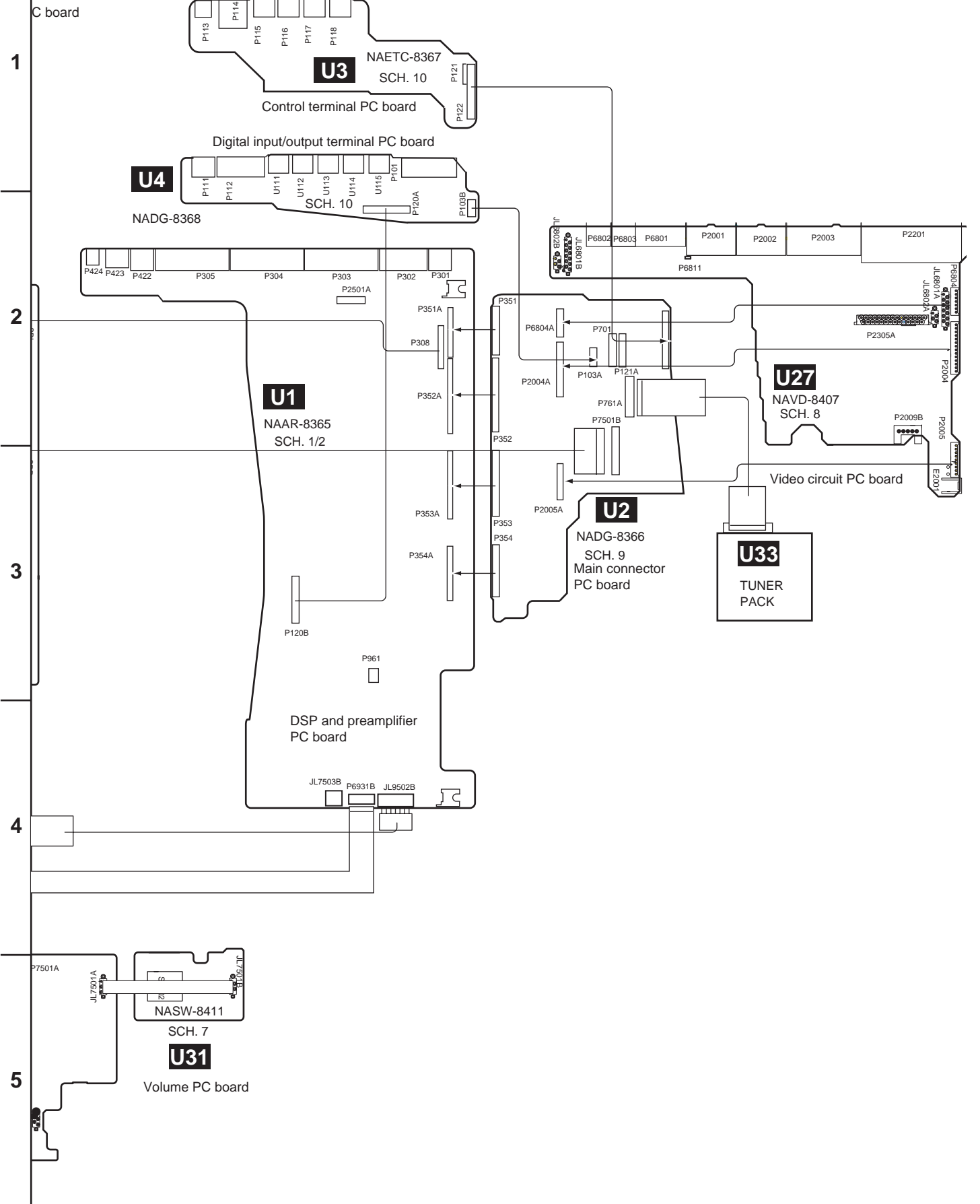

1

2

3

4

5

A

B

C

D

PRINTED CIRCUIT BOARD VIEW 1 FROM COMPONENT SIDE

1

2

3

4

5

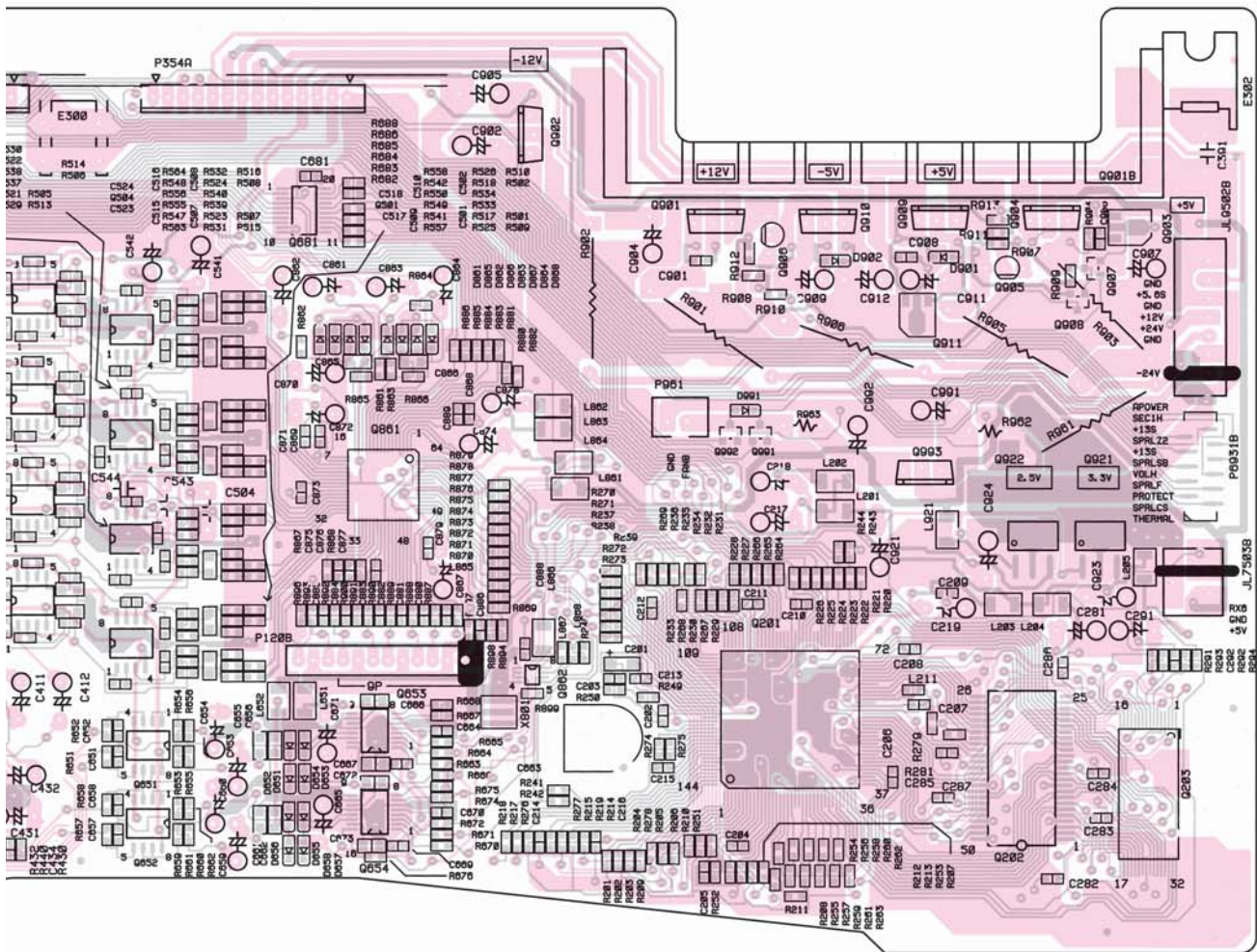

U1 NAAR-8365

DSP and preamplifier PC board

A

B

C

D

PRINTED CIRCUIT BOARD VIEW 2 FROM SOLDERING SIDE

U6

1

2

3

4

5

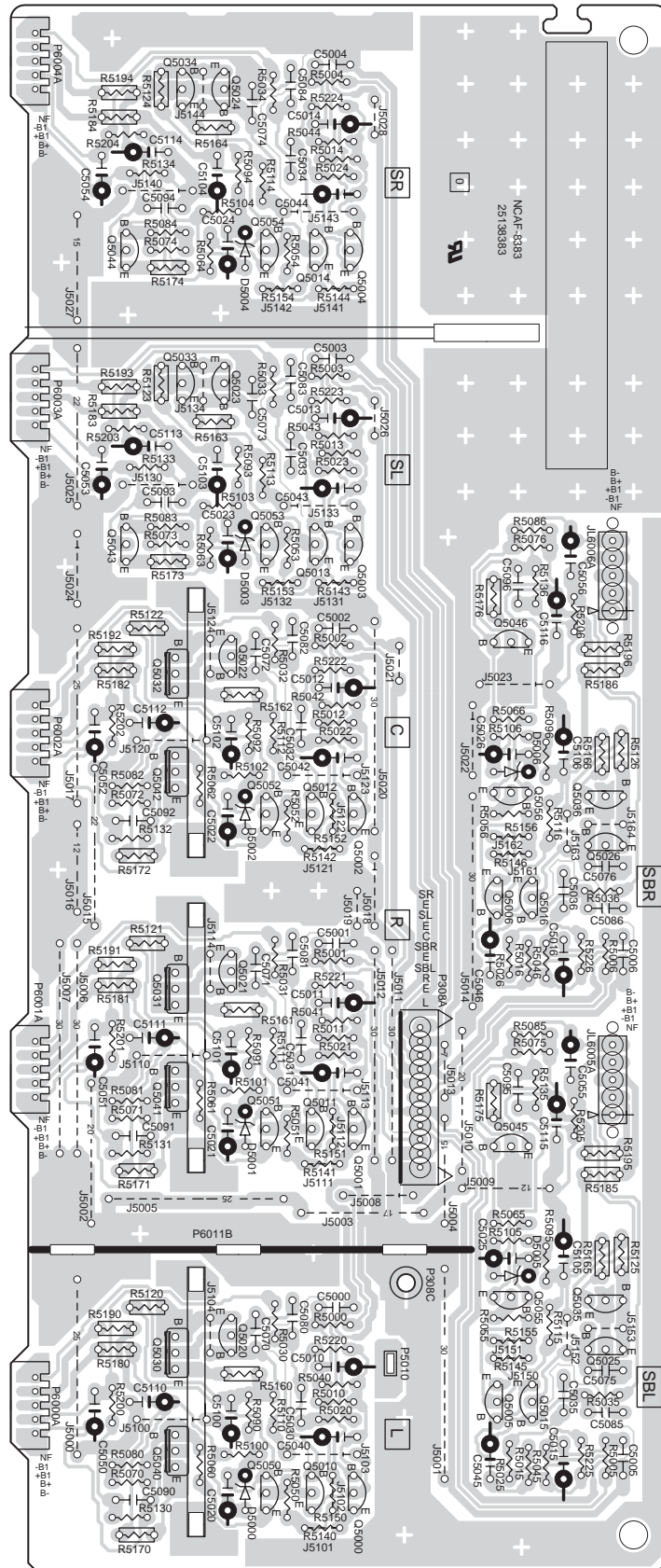

NAAF-8383

Driver circuit PC board

A

B

C

D

PRINTED CIRCUIT BOARD VIEW 3 FROM SOLDERING SIDE

1

2

3

4

5

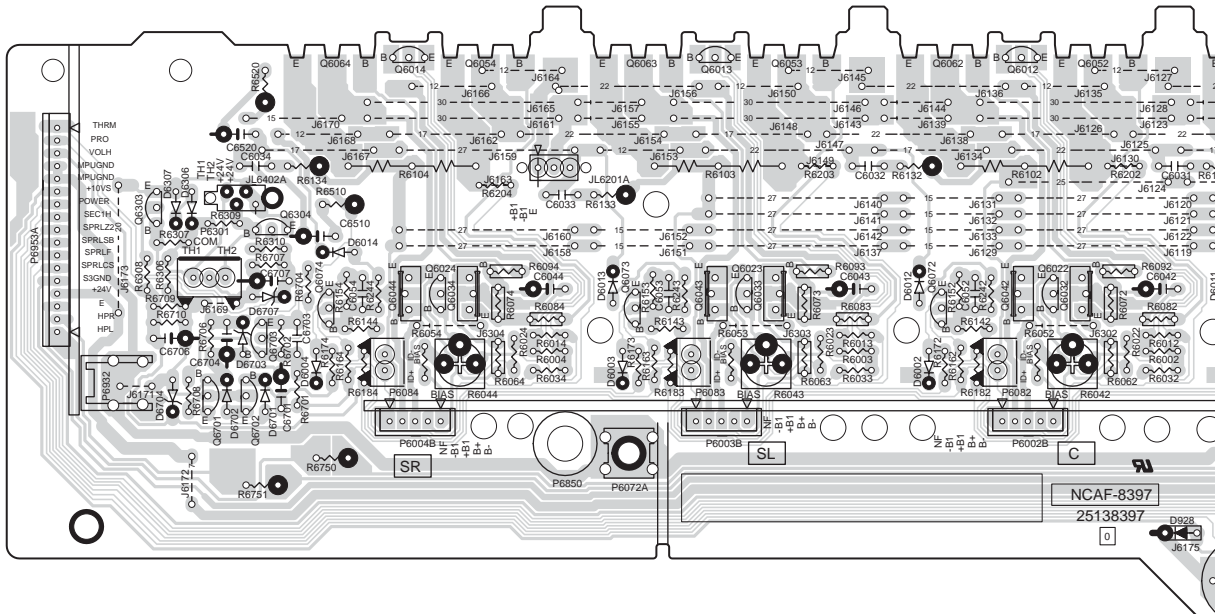

U16 NAAF-8397

Power amplifier PC board

A B C D

PRINTED CIRCUIT BOARD VIEW 3 FROM SOLDERING SIDE

1

2

3

4

5

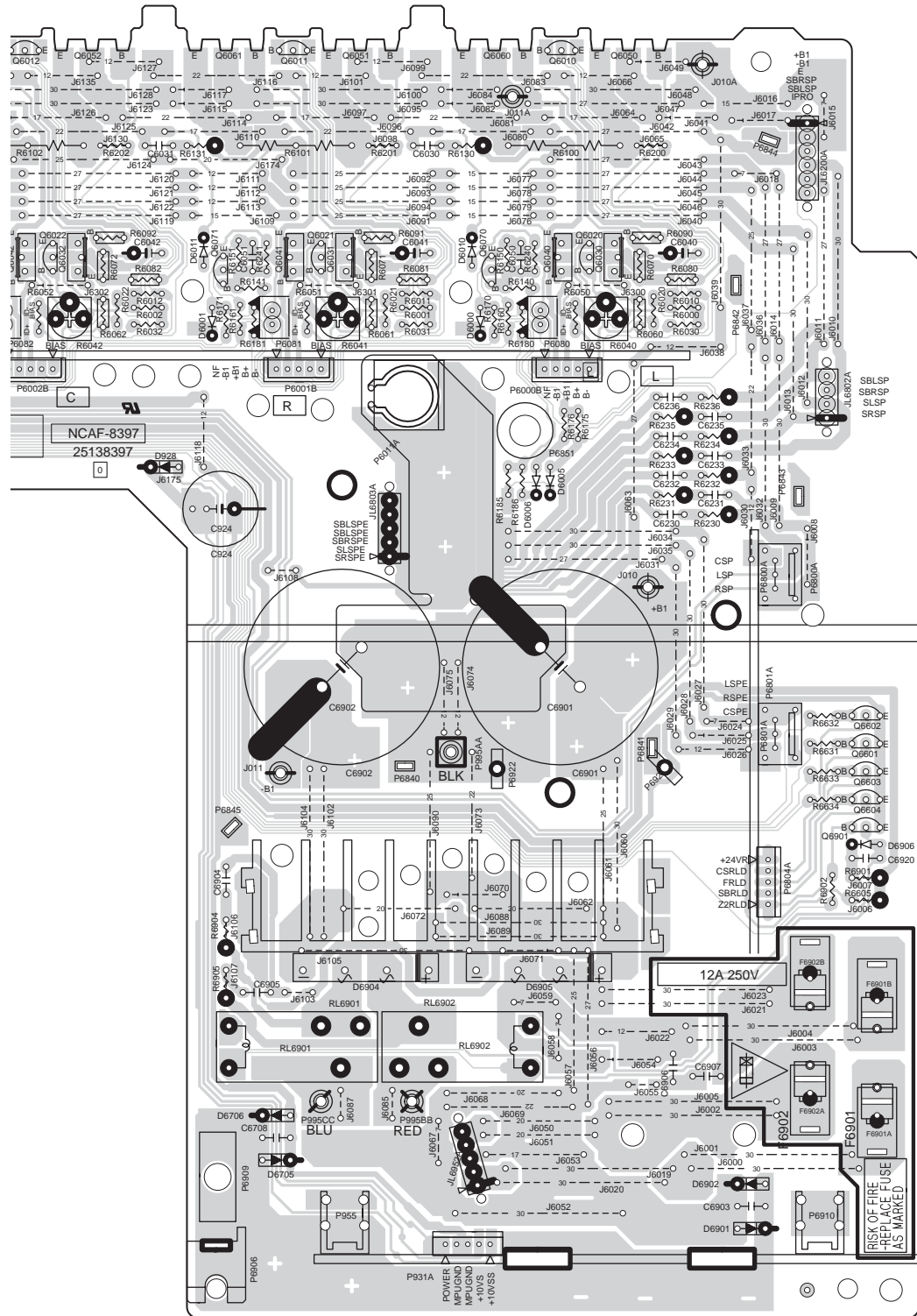

U16 NAAF-8397
 Power amplifier PC board

A

B

C

D

PRINTED CIRCUIT BOARD VIEW 5 FROM SOLDERING SIDE

1

U5

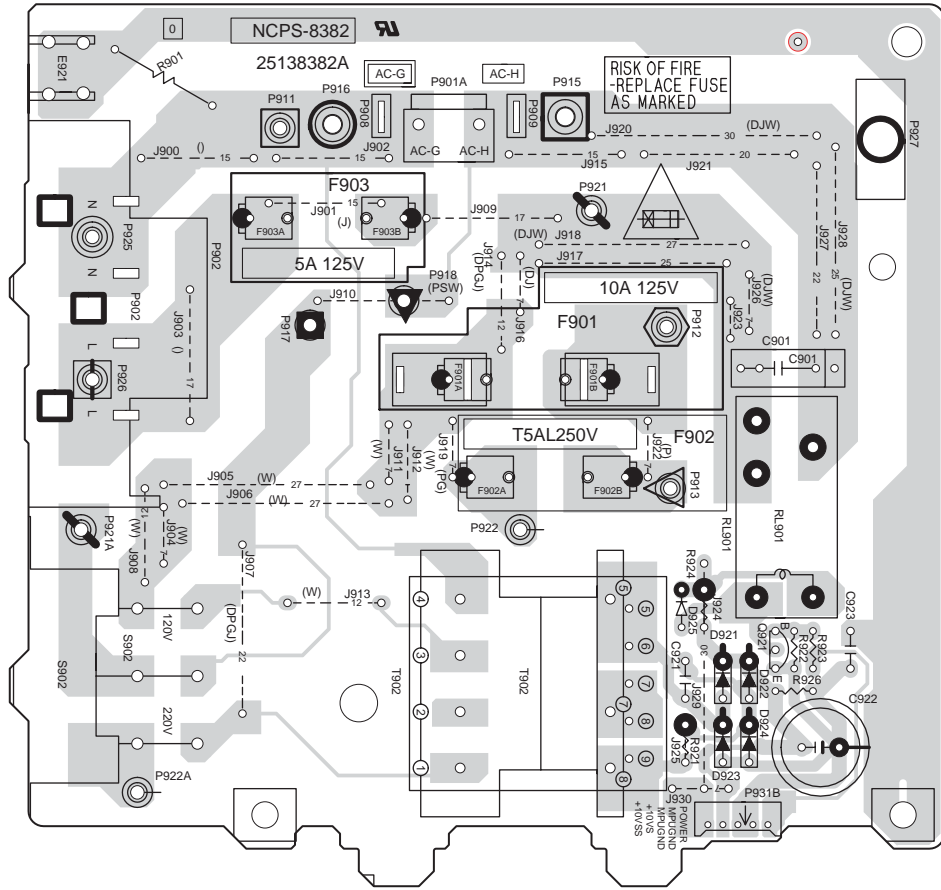

2

3

NAPS-8382 Primary circuit PC board

4

U11

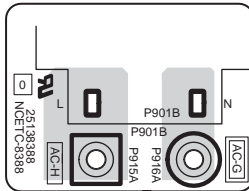

NAETC-8388 AC inlet terminal PC board

5

A B C D

PRINTED CIRCUIT BOARD VIEW 5 FROM SOLDERING SIDE

1

2

3

4

5

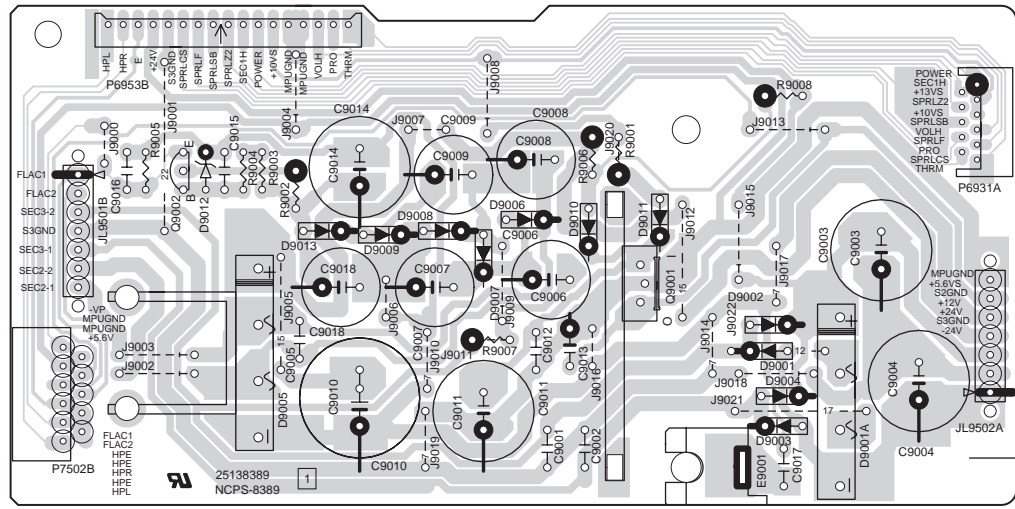

U12 NAPS-8389
Secondary circuit PC board

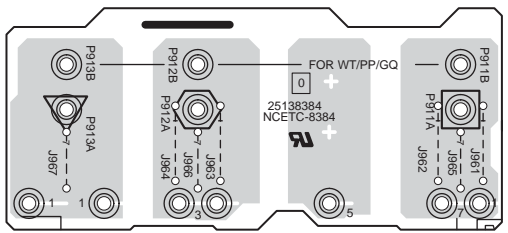

U7 NAETC-8384
Transformer terminal
PC board

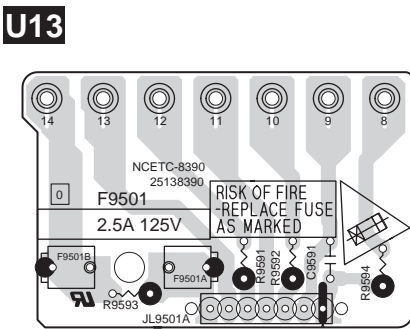

U13
NAETC-8390
Fuse terminal PC board

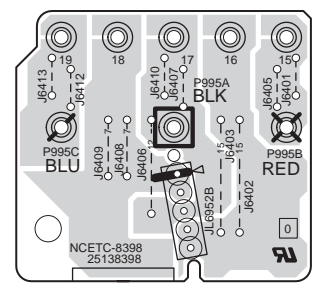

U17
NAETC-8398
Secondary circuit
PC board

A

B

C

D

PRINTED CIRCUIT BOARD VIEW 6

Side A

1

U26

2

3

Side B

4

5

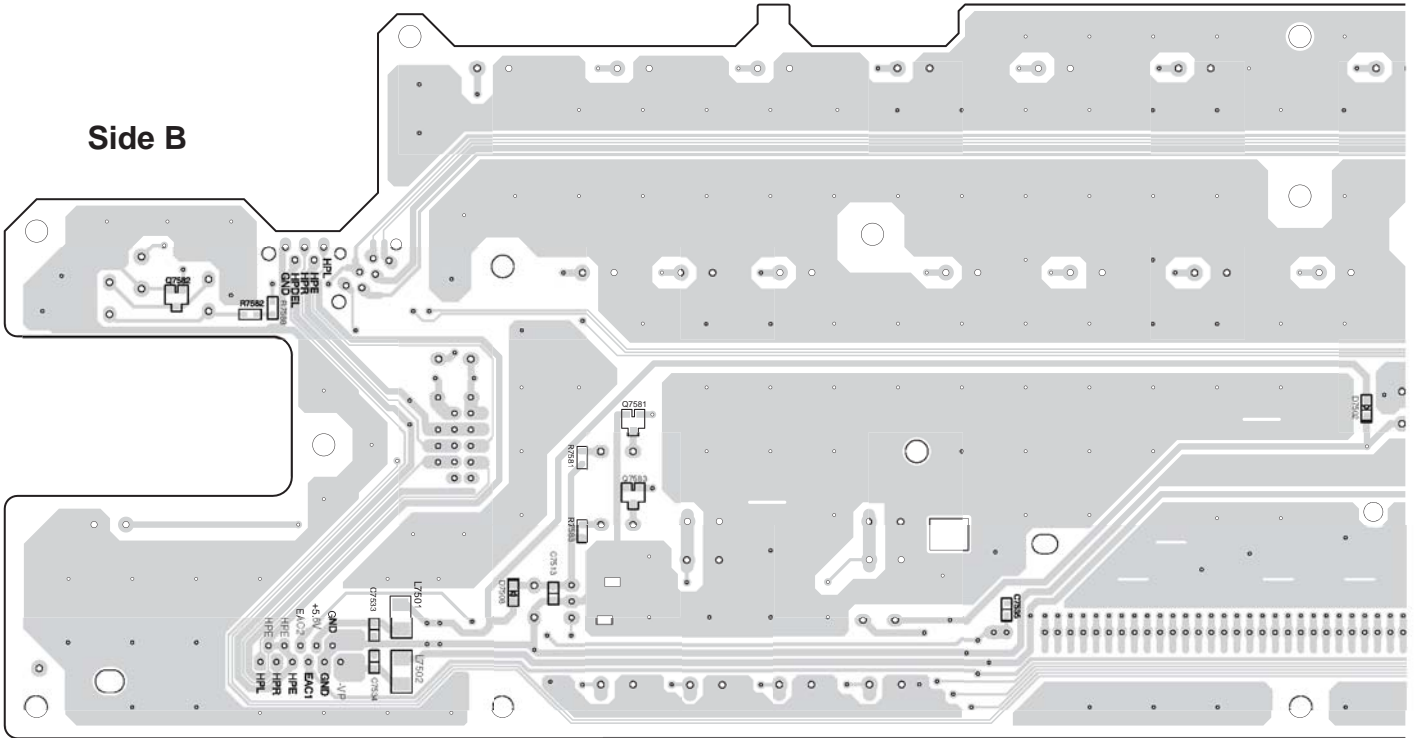
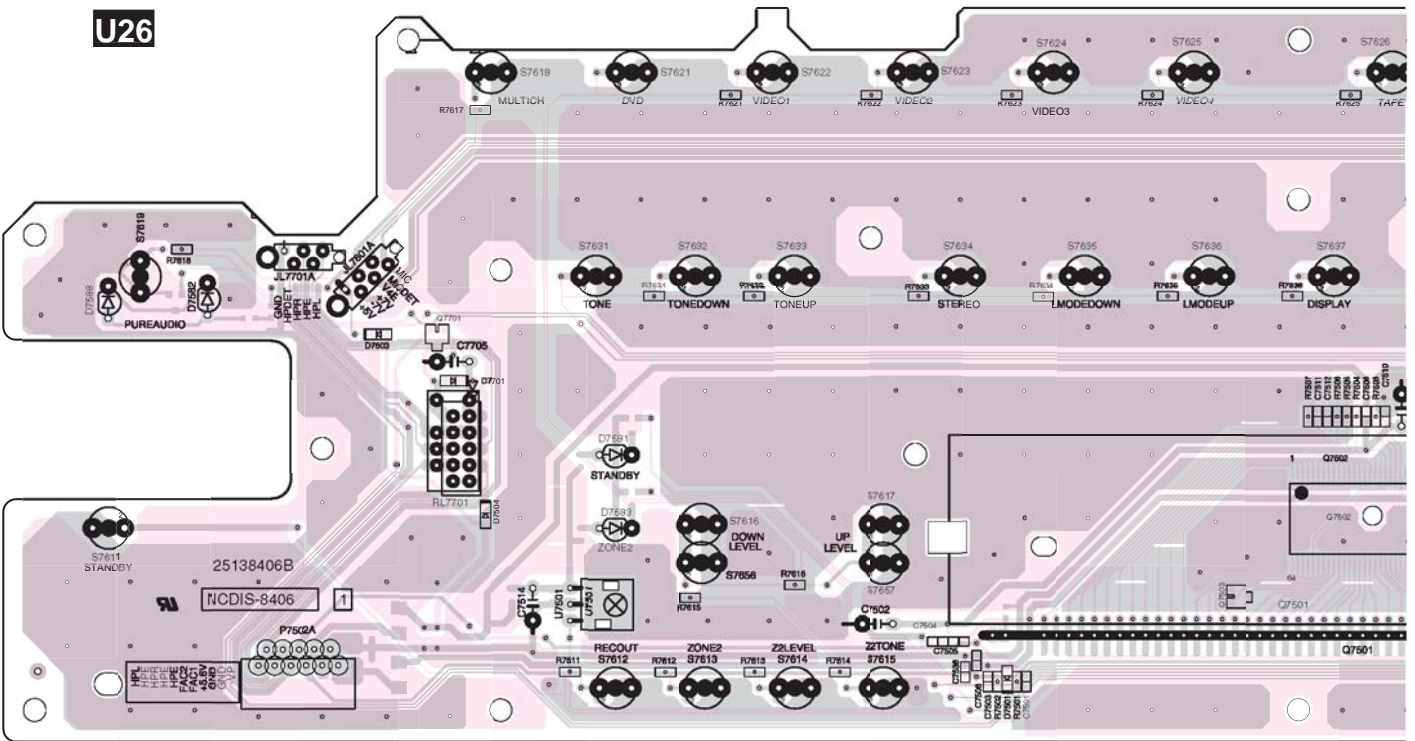

NADIS-8406
Display circuit PC board

A

B

C

D

PRINTED CIRCUIT BOARD VIEW 8

1

2

3

4

5

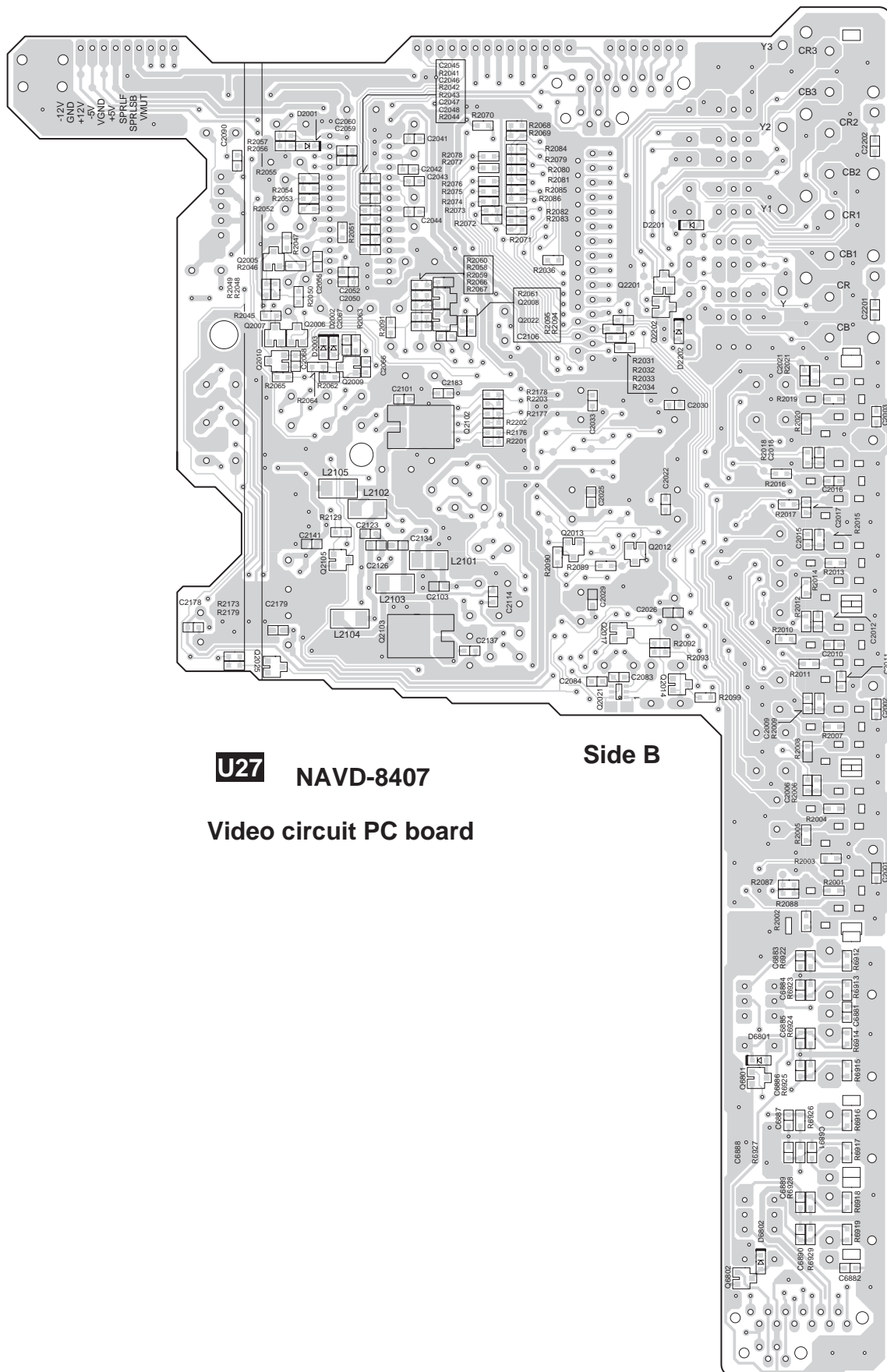

U27 NAVD-8407
Video circuit PC board

Side B

A

B

C

D

PRINTED CIRCUIT BOARD VIEW 8 FROM COMPONENT SIDE

1

2

3

4

5

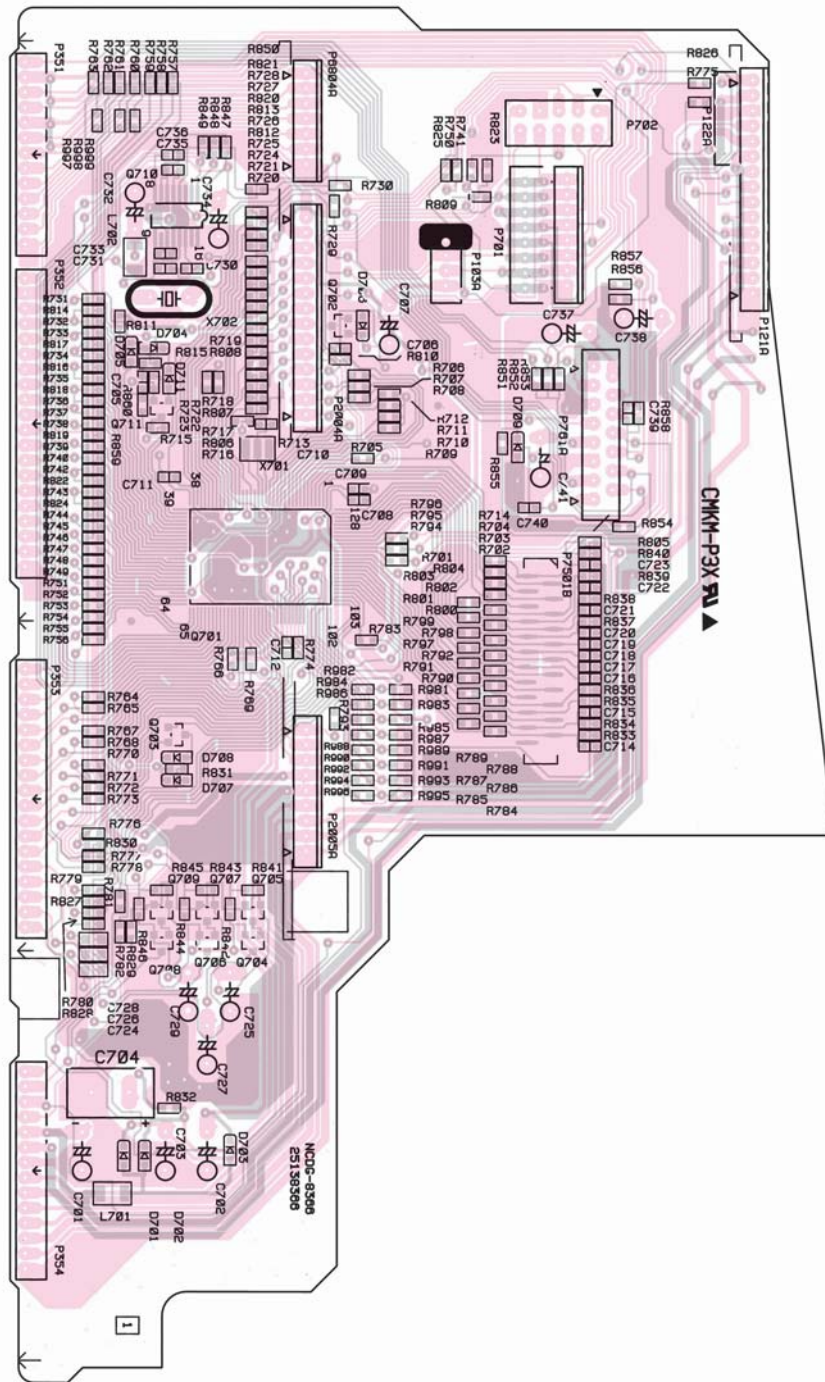

U2 NADG-8366

Main connector
PC board

A

B

C

D

PRINTED CIRCUIT BOARD VIEW 9 FROM COMPONENT SIDE

1

2

3

4

5

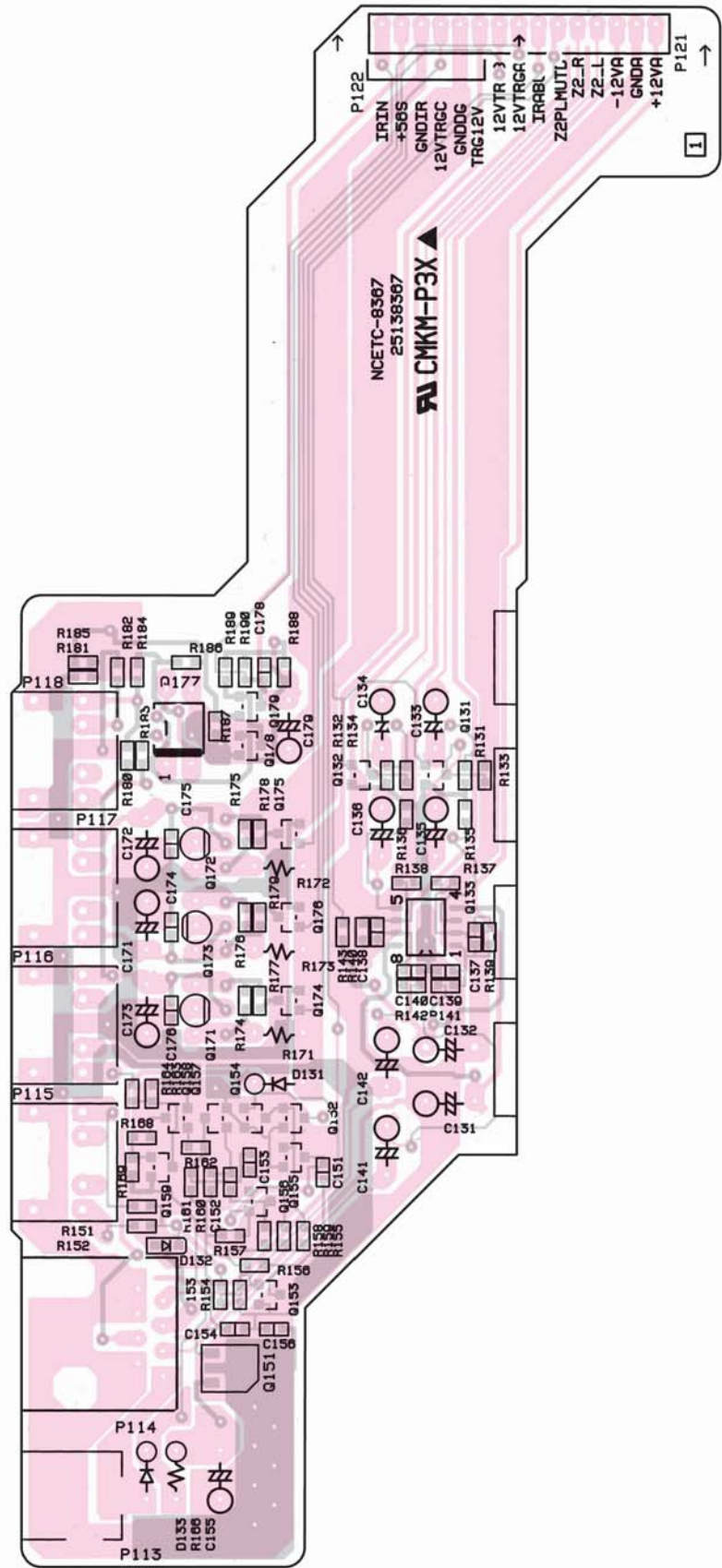

U3

NAETC-8367
Control terminal PC board

A

B

C

D

PRINTED CIRCUIT BOARD VIEW 9 FROM COMPONENT SIDE

1

2

3

4

5

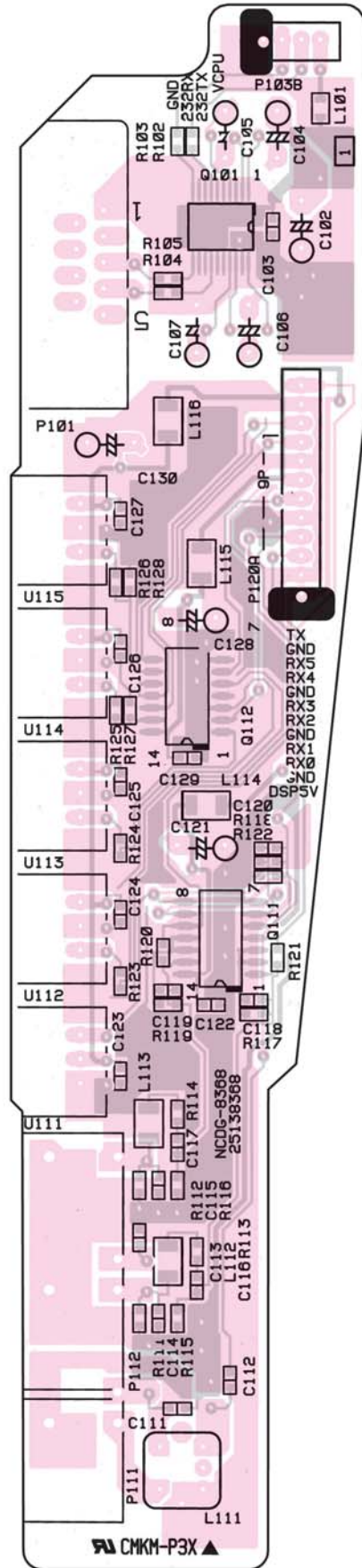

U4 NADG-8368

Digital input/output terminal PC board

IC BLOCK DIAGRAMS AND DESCRIPTION

ADV7172KSTZ(Digital PAL/NTSC Video Encoder with Six DACs)

FUNCTIONAL BLOCK DIAGRAM

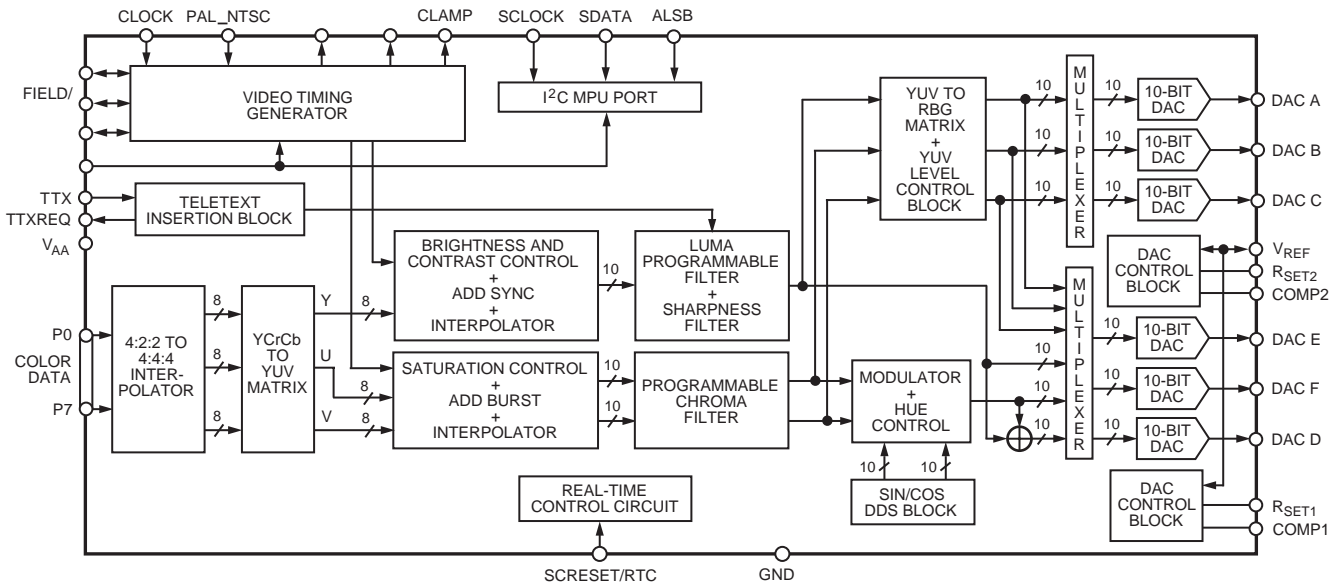

PIN CONFIGURATION

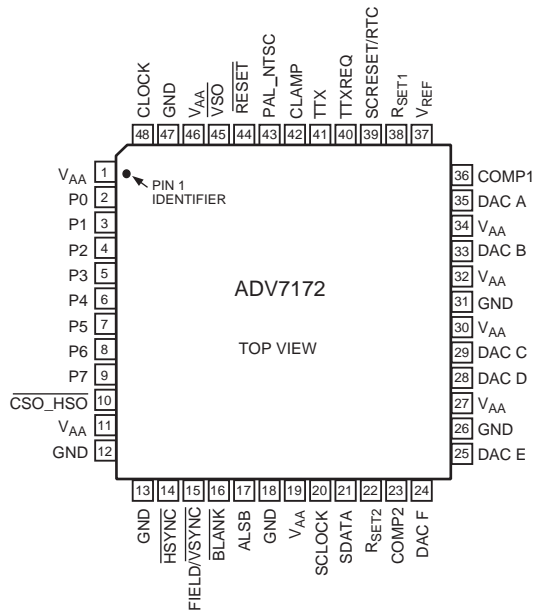

IC BLOCK DIAGRAMS AND DESCRIPTION

ADV7172KSTZ(Digital PAL/NTSC Video Encoder with Six DACs)

PIN FUNCTION DESCRIPTION

Mnemonic	Input/Output	Function
P7–P0	I	8-Bit 4:2:2 Multiplexed YCrCb Pixel Port (P7DP0) P0 represents the LSB.
CLOCK	I	TTL Clock Input. Requires a stable 27 MHz reference clock for standard operation. Alternatively, a 24.5454 MHz (NTSC) or 29.5 MHz (PAL) can be used for square pixel operation.
$\overline{\text{HSYNC}}$	I/O	$\overline{\text{HSYNC}}$ (Modes 1 and 2) Control Signal. This pin may be configured to output (Master Mode) or as an input and accept (Slave Mode) Sync signals.
$\overline{\text{FIELD/VSYNC}}$	I/O	Dual Function $\overline{\text{FIELD}}$ (Mode 1) and $\overline{\text{VSYNC}}$ (Mode 2) Control Signal. This pin may be configured to output (Master Mode) or as an input (Slave Mode) and accept these control signals.
$\overline{\text{BLANK}}$	I/O	Video Blanking Control Signal. The pixel inputs are ignored when this is Logic Level "0." This signal is optional.
SCRESET/RTC	I	This pin can be configured as an input by setting MR42 and MR41 of Mode Register 4. It can be configured as a subcarrier reset pin, in which case a low-to-high transition on this pin will reset the subcarrier phase to Field 0. Alternatively it may be configured as a Real-Time Control (RTC) Input.
V_{REF}	I/O	Voltage Reference Input for DACs or Voltage Reference Output (1.235 V).
R_{SET1}	I	A 150 Ω resistor connected from this pin to GND is used to control full-scale amplitudes of the Video Signals from DACs A, B, and C (the "large" DACs).
R_{SET2}	I	A 600 Ω resistor connected from this pin to GND is used to control full-scale amplitudes of the Video Signals from DACs D, E, and F (the "small" DACs).
COMP1	O	Compensation Pin for DACs A, B, and C. Connect a 0.1 μF Capacitor from COMP to V_{AA} . For Optimum Dynamic Performance in Low Power Mode, the value of the COMP1 capacitor can be lowered to as low as 2.2 nF.
COMP2	O	Compensation Pin for DACs D, E, and F. Connect a 0.1 μF Capacitor from COMP to V_{AA} .
DAC A	O	GREEN/Composite/Y Analog Output. This DAC is capable of providing 34.66 mA output.
DAC B	O	BLUE/S-Video Y/U Analog Output. This DAC is capable of providing 34.66 mA output.
DAC C	O	RED/S-Video C/V Analog Output. This DAC is capable of providing 34.66 mA output.
DAC D	O	GREEN/Composite/Y Analog Output. This DAC is capable of providing 8.66 mA output.
DAC E	O	BLUE/S-Video Y/U Analog Output. This DAC is capable of providing 8.66 mA output.
DAC F	O	RED/S-Video C/V Analog Output. This DAC is capable of providing 8.66 mA output.
SCLOCK	I	MPU Port Serial Interface Clock Input.
SDATA	I/O	MPU Port Serial Data Input/Output.
CLAMP	O	TTL Output Signal to external circuitry to enable clamping of all video signals.
PAL_NTSC	I	Input signal to select PAL or NTSC mode of operation, pin set to Logic "1" selects PAL.
$\overline{\text{VSO}}$	O	$\overline{\text{VSO}}$ TTL Output Sync Signal.
$\overline{\text{CSO_HSO}}$	O	Dual Function $\overline{\text{CSO}}$ or $\overline{\text{HSO}}$ TTL Output Sync Signal.
$\overline{\text{ALSB}}$	I	TTL Address Input. This signal sets up the LSB of the MPU address.
RESET	I	The input resets the on-chip timing generator and sets the ADV7172/ADV7173 into default mode. This is NTSC operation, Timing Slave Mode 0, DACs A, B, and C powered OFF, DACs D, E, and F powered ON, Composite and S-Video out.
TTX	I	Teletext Data Input Pin.
TTXREQ	O	Teletext Data Request output signal used to control teletext data transfer.
V_{AA}	P	Power Supply (3 V to 5 V).
GND	G	Ground Pin.

IC BLOCK DIAGRAMS AND DESCRIPTIONS

ADV7183AKST(Multiformat SDTV Video Decoder)

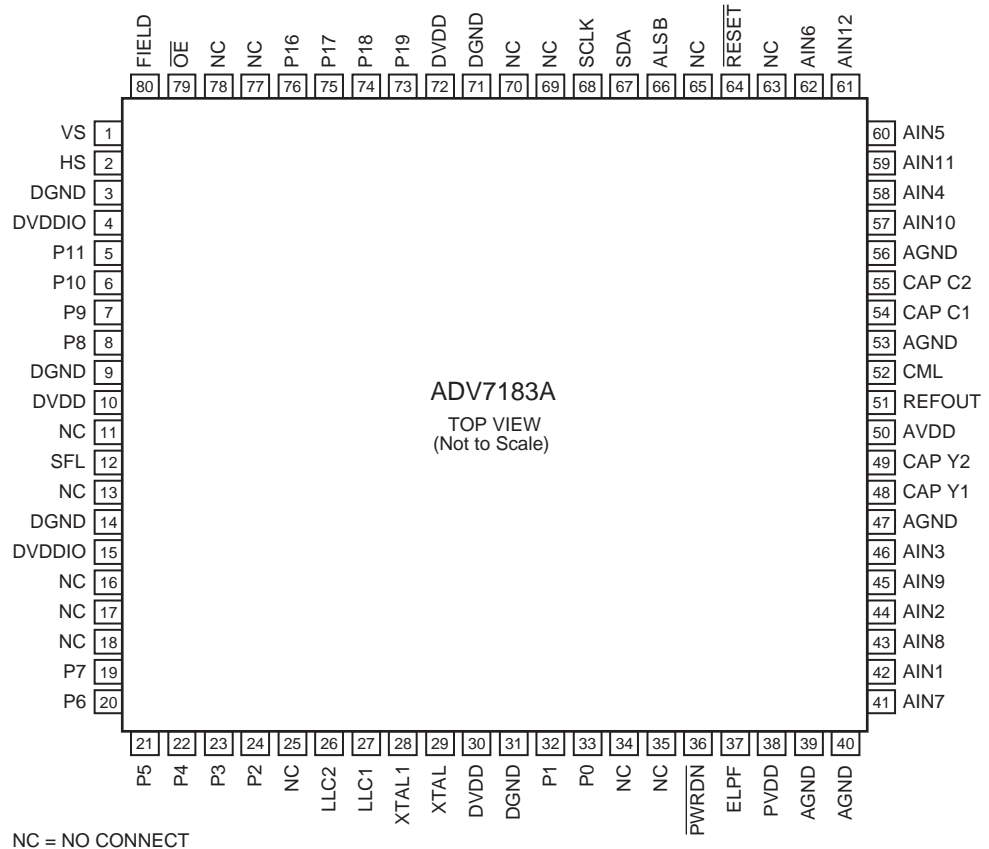
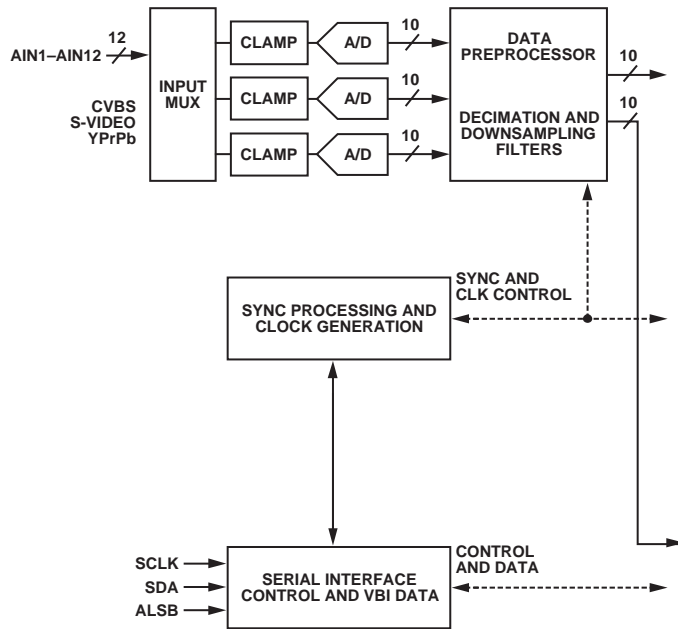

80-lead LQFP pin configuration

IC BLOCK DIAGRAMS AND DESCRIPTIONS

ADV7183AKST(Multiformat SDTV Video Decoder)

Pin Function Descriptions

Pin No.	Mnemonic	Type	Function
3, 9, 14, 31, 71	DGND	G	Digital Ground.
39, 40, 47, 53, 56	AGND	G	Analog Ground.
4, 15	DVDDIO	P	Digital I/O Supply Voltage (3.3 V)
10, 30, 72	DVDD	P	Digital Core Supply Voltage (1.8 V).
50	AVDD	P	Analog Supply Voltage (3.3 V).
38	PVDD	P	PLL Supply Voltage (1.8 V).
41...46, 57...62	AIN1...AIN12	I	Analog Video Input Channels.
11, 13, 16...18, 25, 34, 35, 63, 65, 69, 70, 77, 78	NC		No Connect Pins.
5...8, 19...24, 32, 33, 73...76	P0...P15	O	Video Pixel Output Port.
2	HS	O	HS is a horizontal synchronization output signal.
1	VS	O	VS is a vertical synchronization output signal.
80	FIELD	O	FIELD is a field synchronization output signal.
67	SDA	I/O	I ² C Port Serial Data Input/Output Pin.
68	SCLK	I	I ² C Port Serial Clock Input (Max Clock Rate of 400 kHz).
66	ALSB	I	This pin selects the I ² C address for the ADV7183A. ALSB set to Logic 0 sets the address for a write as 0x40; for ALSB set to logic high, the address selected is 0x42.
64	$\overline{\text{RESET}}$	I	System Reset Input, Active Low. A minimum low reset pulse width of 5 ms is required to reset the ADV7183A circuitry.
27	LLC1	O	This is a line-locked output clock for the pixel data output by the ADV7183A. Nominally 27 MHz, but varies up or down according to video line length.
26	LLC2	O	This is a divide-by-2 version of the LLC1 output clock for the pixel data output by the ADV7183A. Nominally 13.5 MHz, but varies up or down according to video line length.
29	XTAL	I	This is the input pin for the 27 MHz crystal, or can be overdriven by an external 3.3 V, 27 MHz clock oscillator source. In crystal mode, the crystal must be a fundamental crystal.
28	XTAL1	O	This pin should be connected to the 27 MHz crystal or left as a no connect if an external 3.3 V, 27 MHz clock oscillator source is used to clock the ADV7183A. In crystal mode, the crystal must be a fundamental crystal.
36	$\overline{\text{PWRDN}}$	I	A logic low on this pin places the ADV7183A in a power-down mode. Refer to the I ² C Control Register Map for more options on power-down modes for the ADV7183A.
79	$\overline{\text{OE}}$	I	When set to a logic low, $\overline{\text{OE}}$ enables the pixel output bus, P15...P0 of the ADV7183A. A logic high on the $\overline{\text{OE}}$ pin places Pins P15...P0, HS, VS, SE/SYNC_OUT into a high impedance state.
37	ELPF	I	The recommended external loop filter must be connected to this ELPF pin, as shown in Figure 42.
12	SFL	O	Subcarrier Frequency Lock. This pin contains a serial output stream that can be used to lock the subcarrier frequency when this decoder is connected to any Analog Devices, Inc. digital video encoder.
51	REFOUT	O	Internal Voltage Reference Output. Refer to Figure 42 for a recommended capacitor network for this pin.
52	CML	O	The CML pin is a common-mode level for the internal ADCs. Refer to Figure 42 for a recommended capacitor network for this pin.
48, 49	CAPY1, CAPY2	I	ADC s Capacitor Network. Refer to Figure 42 for a recommended capacitor network for this pin.
54, 55	CAPC1, CAPC2	I	ADC s Capacitor Network. Refer to Figure 42 for a recommended capacitor network for this pin.

IC BLOCK DIAGRAMS AND DESCRIPTIONS

CS42518(110dB,192kHz 8-Ch Codec with S/PDIF Receiver)

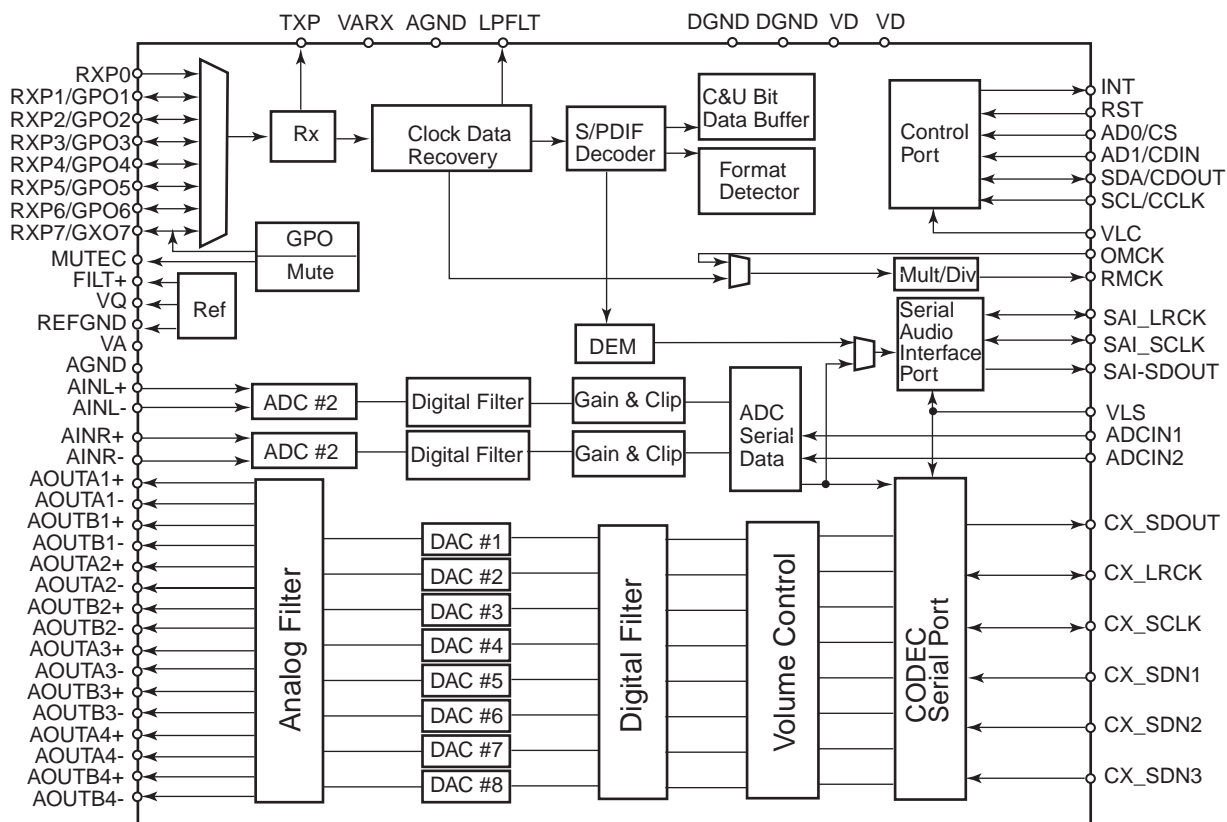

CS5333(24-Bit,96kHz Stereo A/D Converter)

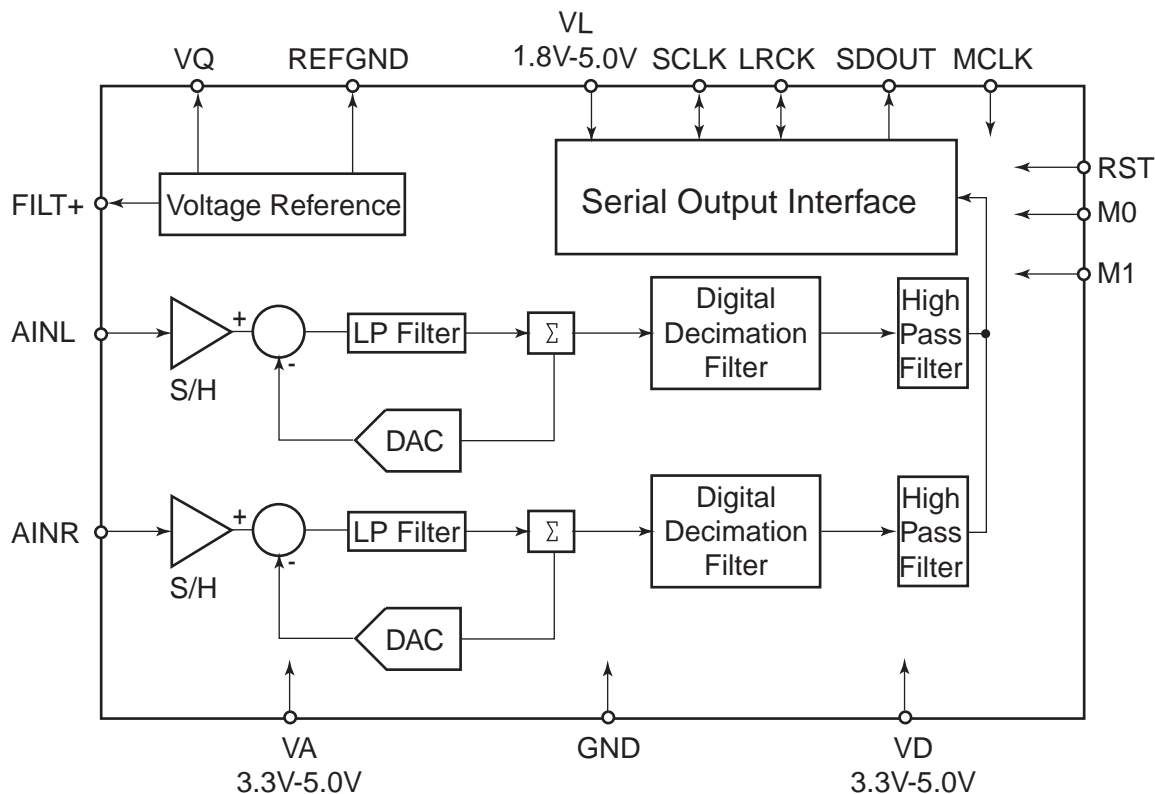

IC BLOCK DIAGRAMS AND DESCRIPTIONS
 CS494003(Audio Decoder DSP)

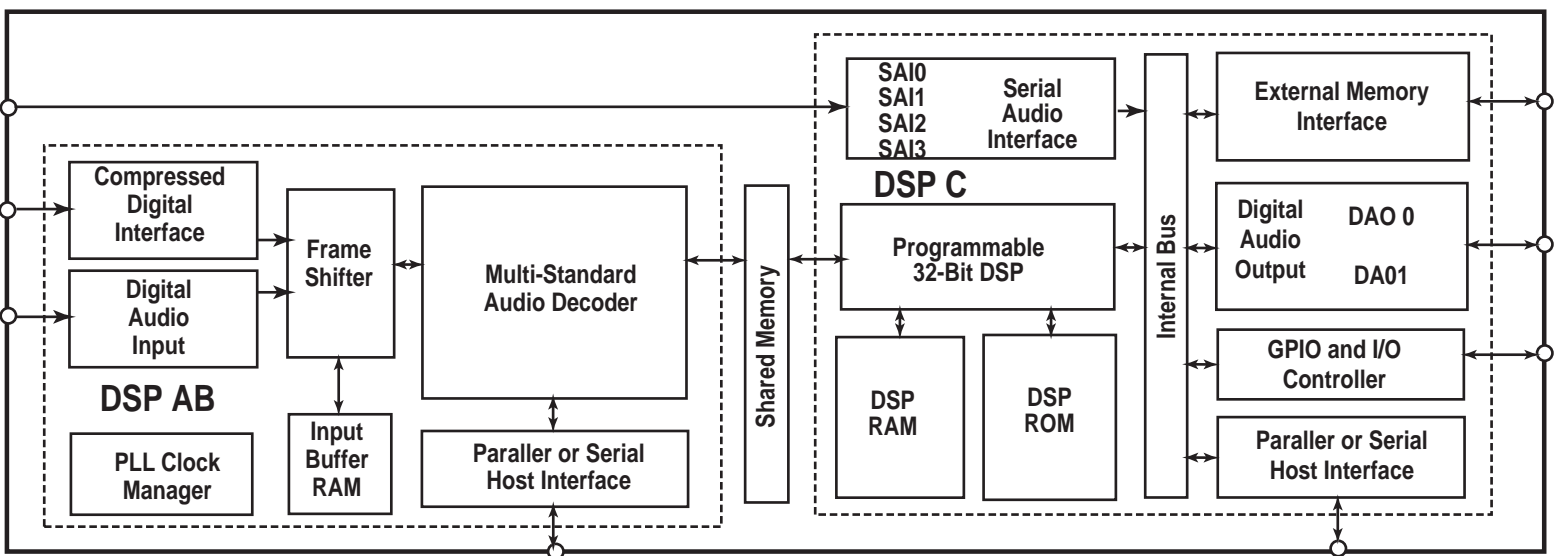

IC BLOCK DIAGRAMS AND TERMINAL DESCRIPTIONS

IC42S16100 (16-Mbit Synchronous Dynamic RAM)

BLOCK DIAGRAM

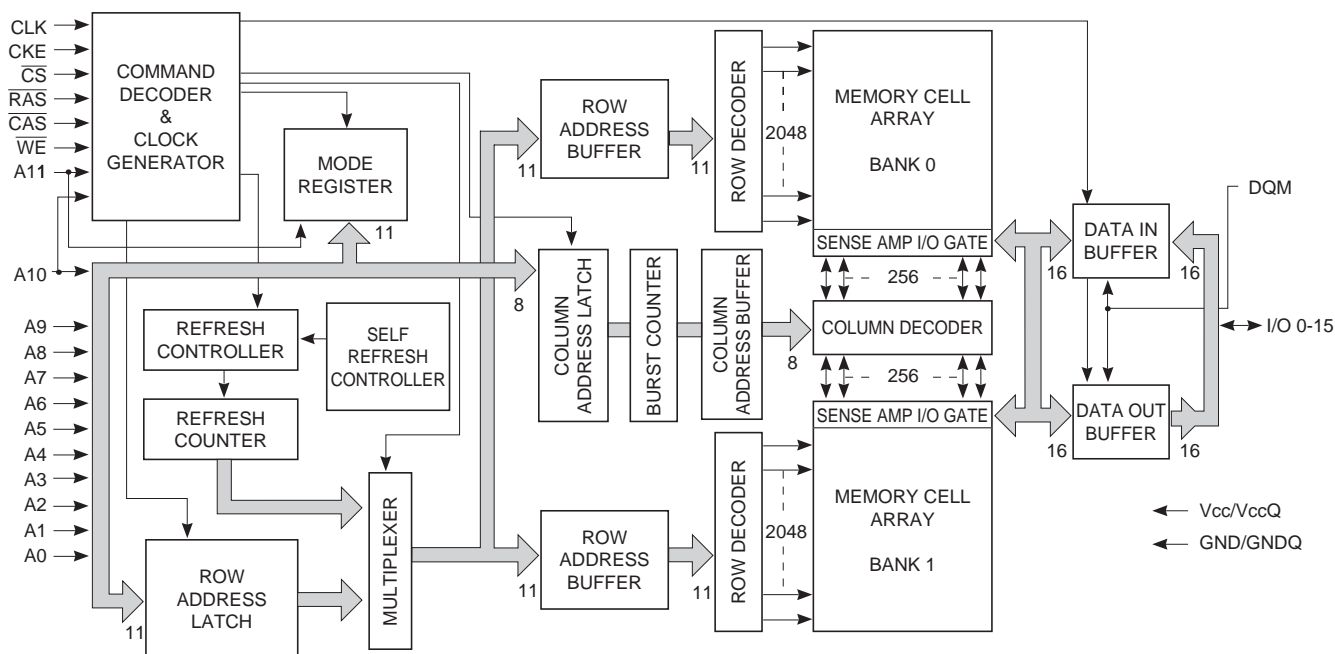

PIN LAYOUT

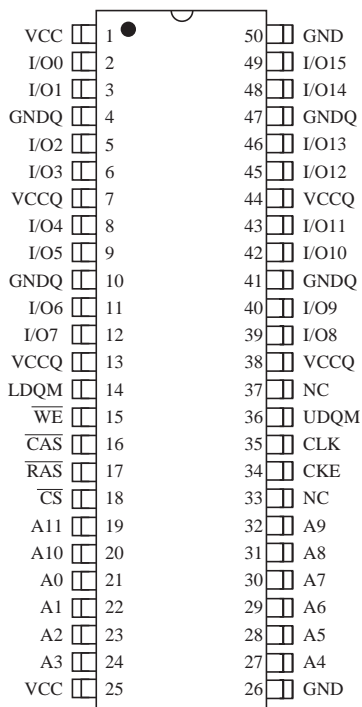

IC BLOCK DIAGRAMS AND TERMINAL DESCRIPTIONS

IC42S16100 (16-Mbit Synchronous Dynamic RAM)

TERMINAL DESCRIPTION

Pin No.	Pin name	Function
20 to 24 27 to 32	A0-A10	A0 to A10 are address inputs. A0-A10 are used as row address inputs during active command input and A0-A7 as column address inputs during read or write command input. A10 is also used to determine the precharge mode during other commands. If A10 is LOW during precharge command, the bank selected by A11 is precharged, but if A10 is HIGH, both banks will be precharged. When A10 is HIGH in read or write command cycle, the precharge starts automatically after the burst access. These signals become part of the OP CODE during mode register set command input.
19	A11	A11 is the bank selection signal. When A11 is LOW, bank 0 is selected and when high, bank 1 is selected. This signal becomes part of the OP CODE during mode register set command input.
16	$\overline{\text{CAS}}$	$\overline{\text{CAS}}$, in conjunction with the $\overline{\text{RAS}}$ and $\overline{\text{WE}}$, forms the device command. See the "Command Truth Table" item for details on device commands.
34	CKE	The CKE input determines whether the CLK input is enabled within the device. When is CKE HIGH, the next rising edge of the CLK signal will be valid, and when LOW, invalid. When CKE is LOW, the device will be in either the power-down mode, the clock suspend mode, or the self refresh mode. The CKE is an asynchronous input.
35	CLK	CLK is the master clock input for this device. Except for CKE, all inputs to this device are acquired in synchronization with the rising edge of this pin.
18	$\overline{\text{CS}}$	The $\overline{\text{CS}}$ input determines whether command input is enabled within the device. Command input is enabled when $\overline{\text{CS}}$ is LOW, and disabled with $\overline{\text{CS}}$ is HIGH. The device remains in the previous state when $\overline{\text{CS}}$ is HIGH.
2, 3, 5, 6, 8, 9, 11, 12, 39, 40, 42, 43, 45, 46, 48, 49	I/O0 to I/O15	I/O0 to I/O15 are I/O pins. I/O through these pins can be controlled in byte units using the LDQM and UDQM pins.
14, 36	LDQM, UDQM	LDQM and UDQM control the lower and upper bytes of the I/O buffers. In read mode, LDQM and UDQM control the output buffer. When LDQM or UDQM is LOW, the corresponding buffer byte is enabled, and when HIGH, disabled. The outputs go to the HIGH impedance state when LDQM/UDQM is HIGH. This function corresponds to $\overline{\text{OE}}$ in conventional DRAMs. In write mode, LDQM and UDQM control the input buffer. When LDQM or UDQM is LOW, the corresponding buffer byte is enabled, and data can be written to the device. When LDQM or UDQM is HIGH, input data is masked and cannot be written to the device.
17	$\overline{\text{RAS}}$	$\overline{\text{RAS}}$, in conjunction with $\overline{\text{CAS}}$ and $\overline{\text{WE}}$, forms the device command. See the "Command Truth Table" item for details on device commands.
15	$\overline{\text{WE}}$	$\overline{\text{WE}}$, in conjunction with $\overline{\text{RAS}}$ and $\overline{\text{CAS}}$, forms the device command. See the "Command Truth Table" item for details on device commands.
7, 13, 38, 44	VccQ	VccQ is the output buffer power supply.
1, 25	Vcc	Vcc is the device internal power supply.
4, 10, 41, 47	GNDQ	GNDQ is the output buffer ground.
26, 50	GND	GND is the device internal ground.

IC BLOCK DIAGRAMS AND DESCRIPTIONS

LA7106MFP(75 ohm video driver)

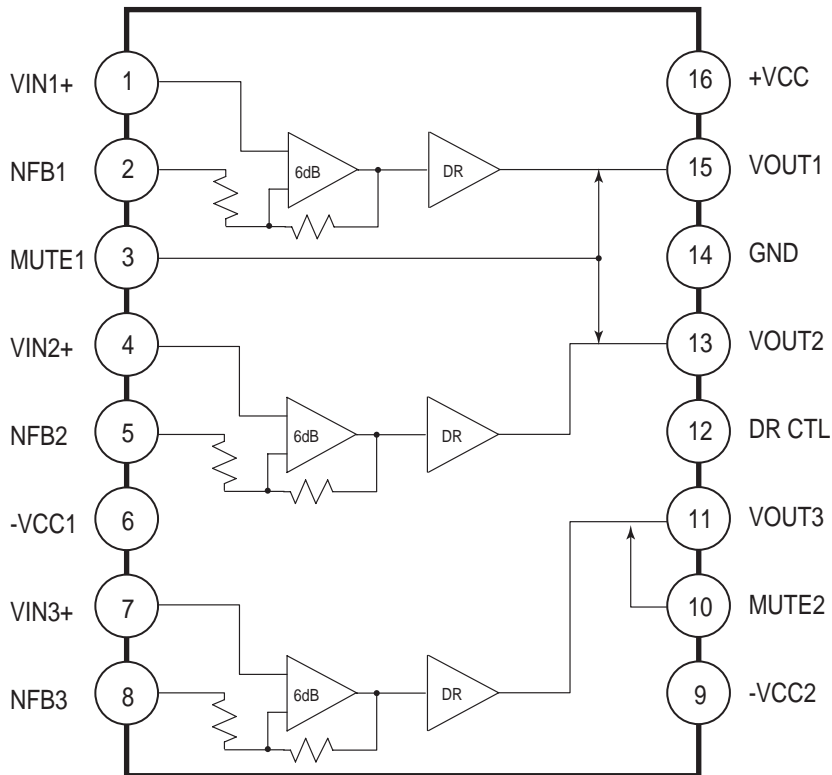

NJM2595M(Video Selector Switch)

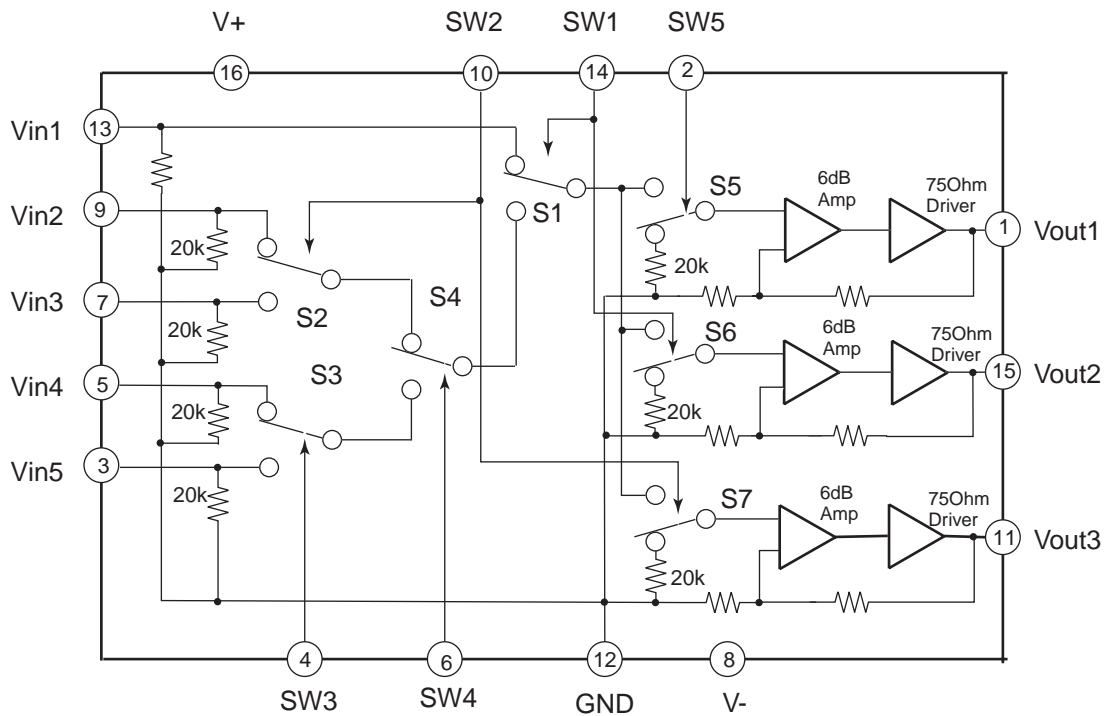

IC BLOCK DIAGRAMS AND DESCRIPTIONS

LC74763-9836(On-screen and controller)

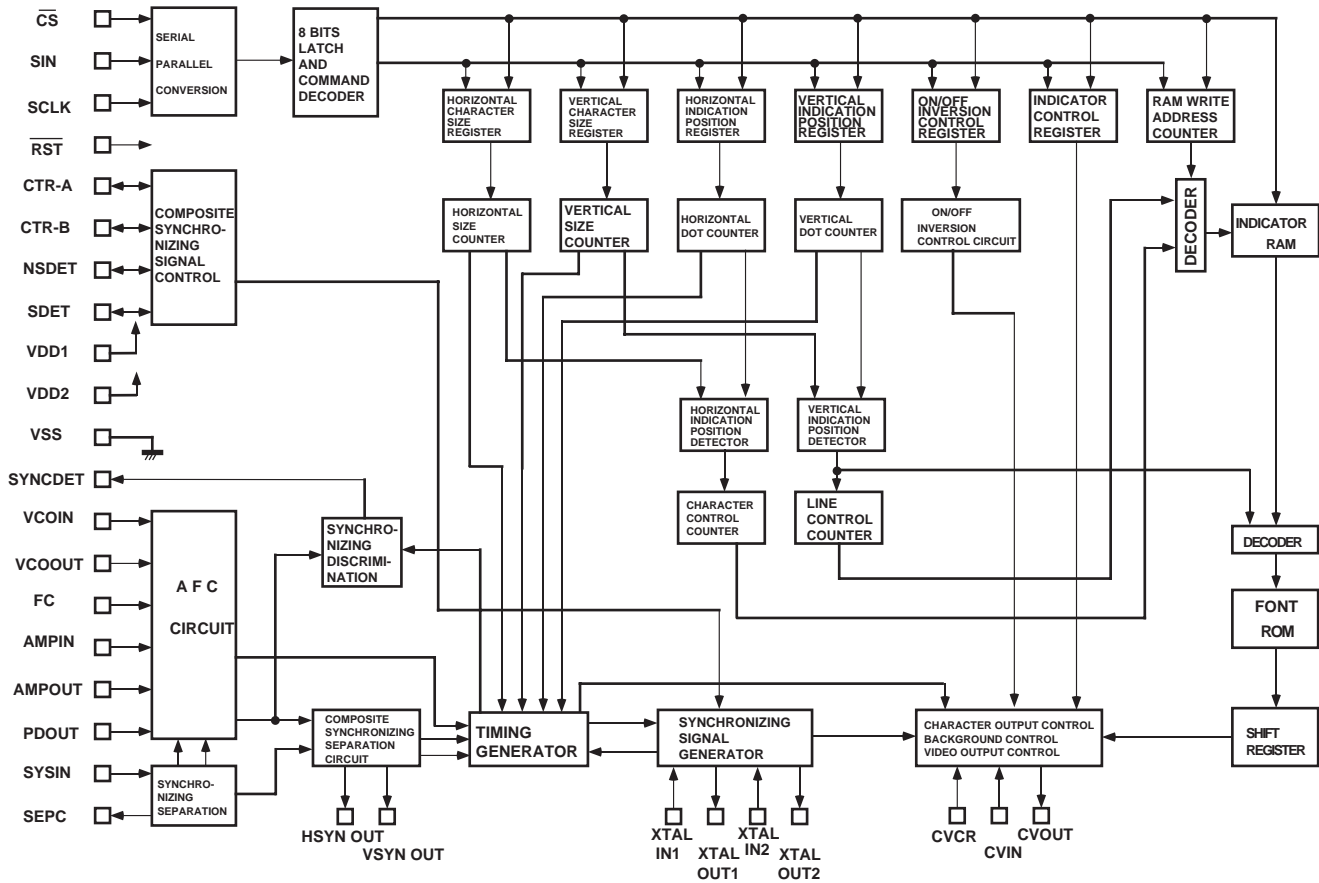

No.	Symbol	Description	No.	Symbol	Description
1	VSS	Ground terminal	16	CVOUT	Composite video output terminal
2	XTALIN1	Crystal oscillator connection terminals for.	17	VDD2	Power supply terminal for composite video signal
3	XTALOUT1	internal synchronizing signal generator	18	CVIN	Composite video signal input terminal
4	HSYNCOOUT	Horizontal synchronizing signal output terminal	19	CVCR	Chromatic signal input terminal
5	XTALIN2	Crystal oscillator connection terminals for	20	SYNCIN	Video signal input terminal for internal synchronizing separation circuit
6	XTALOUT2	internal synchronizing signal generator	21	SEPC	Bias output pin for internal synchronizing separation circuit
7	VSYNCOOUT	Vertical synchronizing signal output terminal	22	VSS	Ground terminal
8	CS	Chip enable input terminal	23	PDOUT	Power supply output terminal for AFC circuit
9	SIN	Serial data input terminal	24	AMPIN	Filter connection terminals
10	SCLK	Clock input terminal for serial data	25	AMPOUT	
11	CTR-A	Video control output terminal	26	FC	Power supply output terminal
12	CTR-B	Video control output terminal	27	VCOIN	LC resonator connection terminals for VCO
13	NSDET	Selection pin for PAL or NTSC	28	VCOOUT	
14	SDET	Signal detection terminal	29	SYNCDET	External synchronizing signal discrimination output terminal
15	RST	System reset input terminal	30	VDD1	Power supply terminal

IC BLOCK DIAGRAMS AND DESCRIPTIONS

M66005-0001AFP(FL tube drive IC)

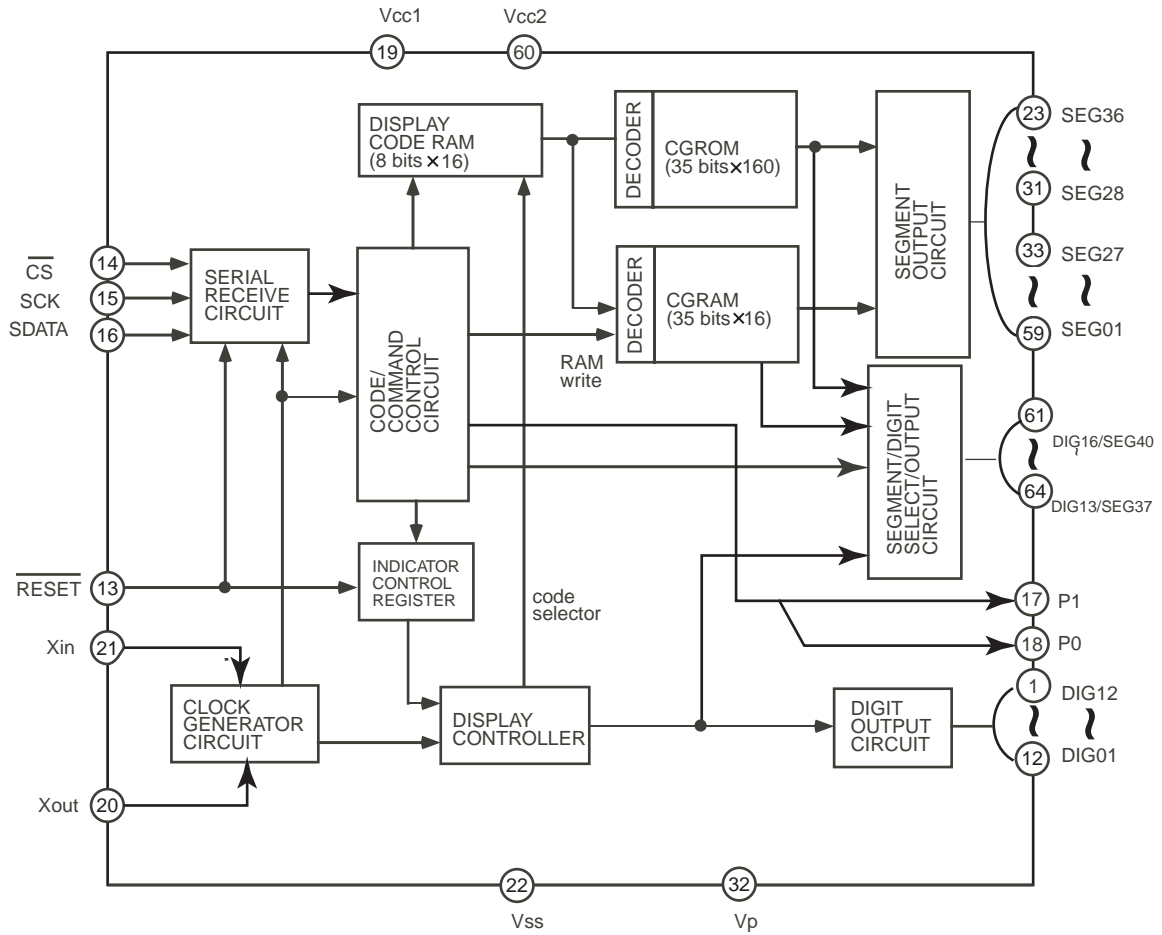

IC BLOCK DIAGRAMS AND DESCRIPTIONS

uPD4721GS (RS-232C Driver/ Receiver)

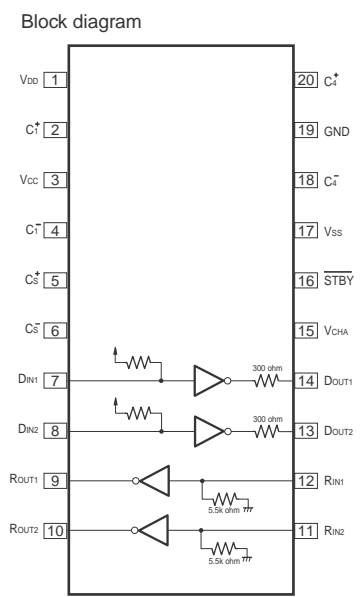

Truth table

Driver

STBY	DIN	DOUT	Remarks
L	X	Z	Standby mode (DC/DC converter is stopped)
H	L	H	Space level output
H	H	L	Mark level output

Receiver

STBY	RIN	ROUT	Remarks
L	X	H	Standby mode (DC/DC converter is stopped)
H	L	H	Space level input
H	H	L	Space level input

3 V/5 V switching

VCHA	Operating mode
L	5 V mode (double step-up)
H	3 V mode (3 times step-up)

IC BLOCK DIAGRAMS AND TERMINAL DESCRIPTIONS

MX29LV040 (4M-Bit CMOS Single Voltage 3V Only Equal Sector Flash Memory)

BLOCK DIAGRAM

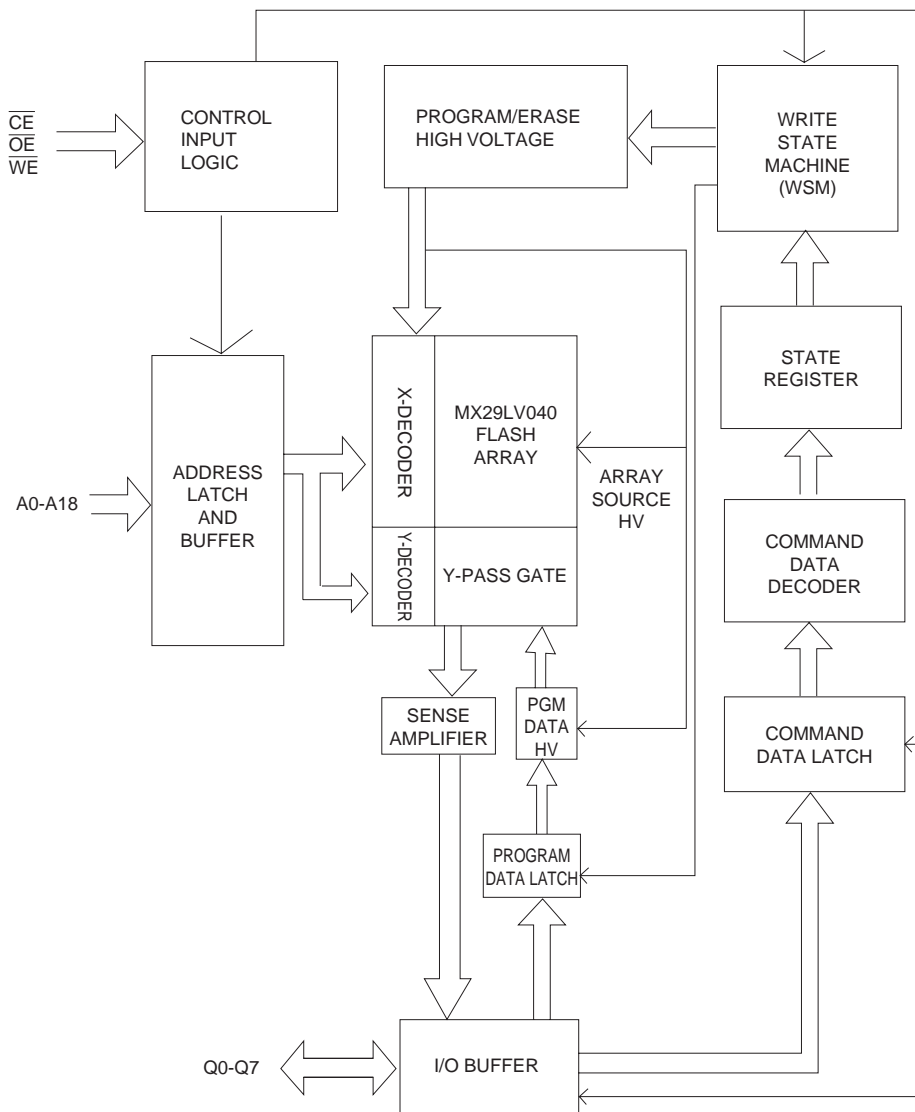

TERMINAL DESCRIPTION

PIN LAYOUT

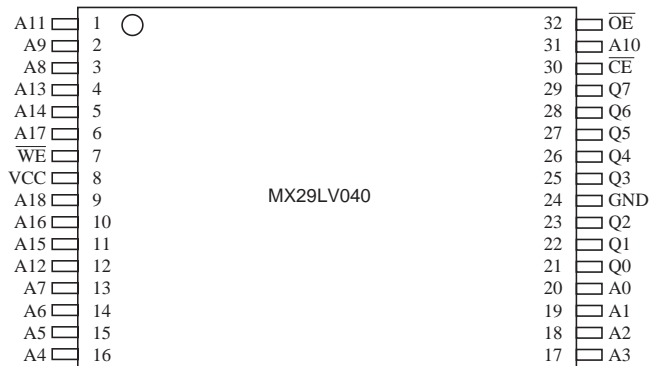

Pin Name	Description
A0~A18	Address Input
Q0~Q7	Data Input/Output
\overline{CE}	Chip Enable Input
\overline{WE}	Write Enable Input
\overline{OE}	Output Enable Input
GND	Ground Pin
VCC	+3.0V single power supply

IC BLOCK DIAGRAMS AND DESCRIPTIONS

NJW1157(8-Channel Electronic Volume with Input Selector)

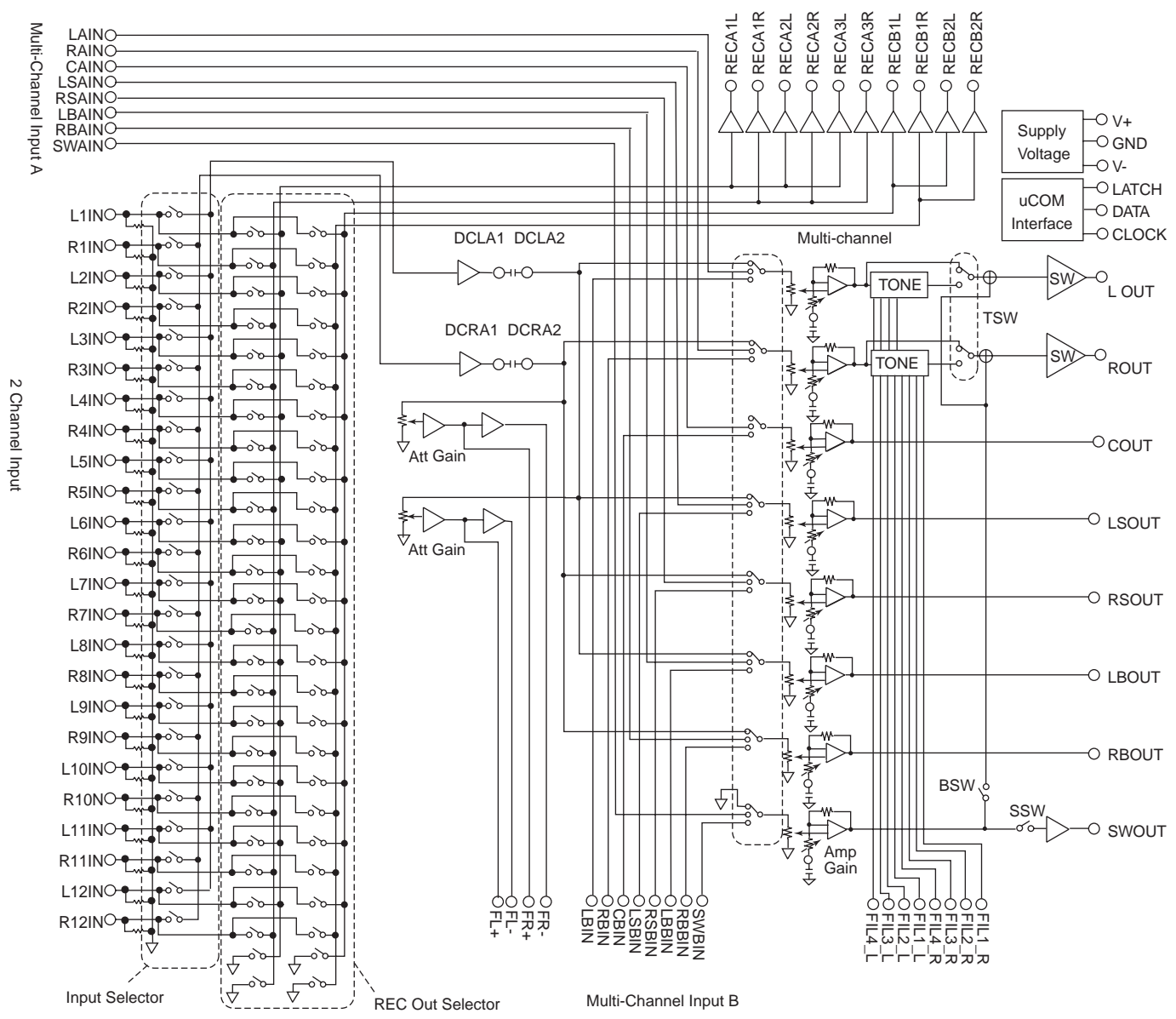

IC BLOCK DIAGRAMS AND DESCRIPTIONS

NJW1157(8-Channel Electronic Volume with Input Selector)

PIN FUNCTION

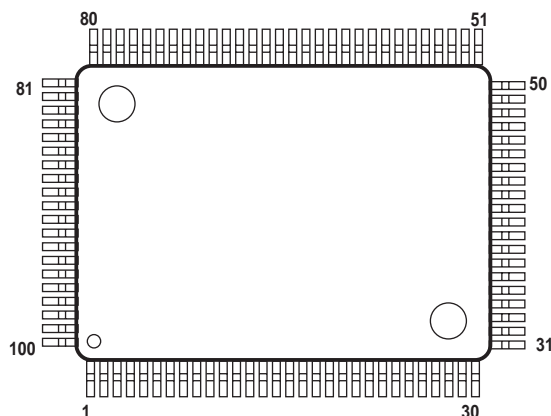

No.	SYMBOL	FUNCTION	No.	SYMBOL	FUNCTION
1	LOUT	Lch output	51	L1IN	"Input selector" Lch input 1
2	ROUT	Rch output	52	R1IN	"Input selector" Rch input 1
3	COOUT	Cch output	53	L2IN	"Input selector" Lch input 2
4	LSOUT	LSch output	54	R2IN	"Input selector" Rch input 2
5	RSOUT	RSch output	55	L3IN	"Input selector" Lch input 3
6	LBOUT	LBch output	56	R3IN	"Input selector" Rch input 3
7	RBOUT	RBch output	57	L4IN	"Input selector" Lch input 4
8	SWOUT	SWch output	58	R4IN	"Input selector" Rch input 4
9	DC_L1	Lch Bass filter DC cut capacitor output terminal	59	L5IN	"Input selector" Lch input 5
10	DC_L2	Lch Bass filter DC cut capacitor input terminal	60	R5IN	"Input selector" Rch input 5
11	FIL_BL	Lch Bass filter terminal	61	L6IN	"Input selector" Lch input 6
12	FIL_TL	Lch Treble filter terminal	62	R6IN	"Input selector" Rch input 6
13	DC_R1	Rch Bass filter DC cut capacitor output terminal	63	L7IN	"Input selector" Lch input 7
14	DC_R2	Rch Bass filter DC cut capacitor input terminal	64	R7IN	"Input selector" Rch input 7
15	FIL_BR	Rch Bass filter terminal	65	L8IN	"Input selector" Lch input 8
16	FIL_TR	Rch Treble filter terminal	66	R8IN	"Input selector" Rch input 8
17	N.C.	No connect	67	L9IN	"Input selector" Lch input 9
18	N.C.	No connect	68	R9IN	"Input selector" Rch input 9
19	V+	+ Power supply voltage input	69	L10IN	"Input selector" Lch input 10
20	V-*	- Power supply voltage input	70	R10IN	"Input selector" Rch input 10
21	REC_A1L	"Input selector" Lch REC output A1	71	L11IN	"Input selector" Lch input 11
22	REC_A1R	"Input selector" Rch REC output A1	72	R11IN	"Input selector" Rch input 11
23	REC_A2L	"Input selector" Lch REC output A2	73	L12IN	"Input selector" Lch input 12
24	REC_A2R	"Input selector" Rch REC output A2	74	R12IN	"Input selector" Rch input 12
25	REC_A3L	"Input selector" Lch REC output A3	75	NC	No connect
26	REC_A3R	"Input selector" Rch REC output A3	76	DGND	Digital Ground
27	REC_B1L	"Input selector" Lch REC output B1	77	DATA	Control data signal input
28	REC_B1R	"Input selector" Rch REC output B1	78	CLOCK	Clock signal input
29	REC_B2L	"Input selector" Lch REC output B2	79	LATCH	Latch signal input
30	REC_B2R	"Input selector" Rch REC output B2	80	LAIN	Multi-channel Lch input A
31	DCCAP_L	Switching noise rejection capacitor	81	RAIN	Multi-channel Rch input A
32	DCCAP_R	Switching noise rejection capacitor	82	CAIN	Multi-channel Cch input A
33	DCCAP_C	Switching noise rejection capacitor	83	LSAIN	Multi-channel LSch input A
34	GND	Ground	84	RSAIN	Multi-channel RSch input A
35	GND	Ground	85	LBAIN	Multi-channel LBch input A
36	DCCAP_LS	Switching noise rejection capacitor	86	RBAIN	Multi-channel RBch input A
37	DCCAP_RS	Switching noise rejection capacitor	87	SWAIN	Multi-channel SWch input A
38	DCCAP_LB	Switching noise rejection capacitor	88	LBIN	Multi-channel Lch input B
39	DCCAP_RB	Switching noise rejection capacitor	89	RBIN	Multi-channel Rch input B
40	DCCAP_SW	Switching noise rejection capacitor	90	CBIN	Multi-channel Cch input B
41	DCL_OUT	"Input selector" Lch output	91	LSBIN	Multi-channel LSch input B
42	DCL_IN	"Multi-channel selector" Lch output	92	RSBIN	Multi-channel RSch input B
43	DCR_OUT	"Input selector" Rch output	93	LBBIN	Multi-channel LBch input B
44	DCR_IN	"Multi-channel selector" Rch output	94	RBBIN	Multi-channel RBch input B
45	FL+	"Input selector gain control" Lch no-inverted output	95	SWBIN	Multi-channel SWch input B
46	FL-	"Input selector gain control" Lch inverted output	96	GND	Ground
47	FR+	"Input selector gain control" Rch no-inverted output	97	GND	Ground
48	FR-	"Input selector gain control" Rch inverted output	98	VSSOUT2	Internal Digital -Power Supply Output 2
49	VDDOUT	Internal Digital +Power Supply Output	99	VDDOUT2	Internal Digital +Power Supply Output 2
50	VSSOUT	Internal Digital -Power Supply Output	100	TCCAP	Switching noise rejection capacitor

IC BLOCK DIAGRAMS AND DESCRIPTIONS

TC9162BFG(Function Switch)

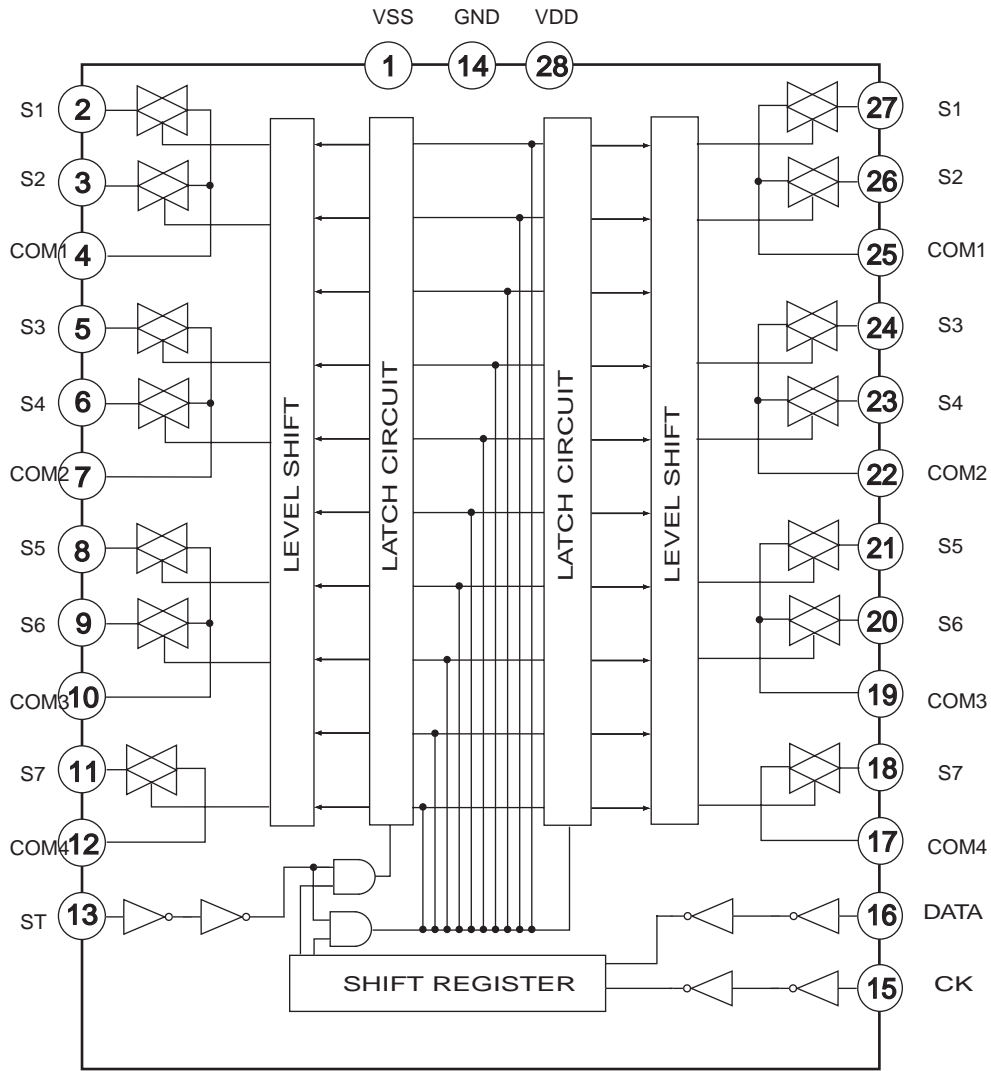

Pin No.	Symbol	Function
1	Vss	Negative power supply
14	GND	Ground
28	VDD	Positive power supply
2,3,5,6,8,9,11	S1~S7	Input/output terminals
27,26,24,23,21,20,18	S1~S7	Input/output terminals
4,7,10,12	COM1 ~ COM4	Common terminals
25,22,19,17	COM1 ~ COM4	Common terminals
13	ST	Strobe input terminal for data reading
15	CK	Clock input terminal for data transfer
16	DATA	Data input terminal for switch

IC BLOCK DIAGRAMS AND DESCRIPTIONS

TC9164AF(Function switch)

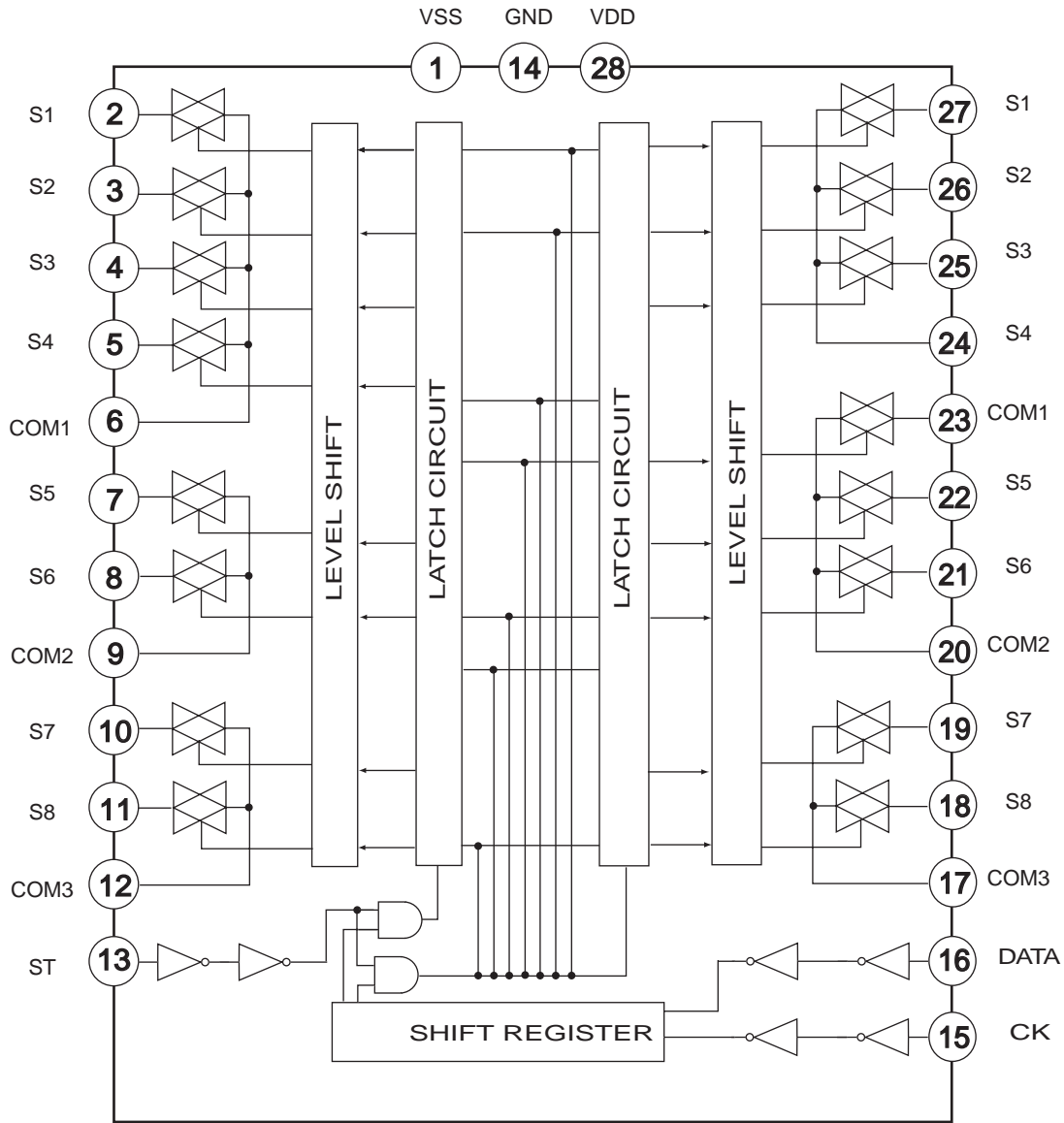

Pin No.	Symbol	Function
1	Vss	Negative power supply
14	GND	Ground
28	VDD	Positive power supply
2,3,4,6,7,8,10,11	S1~S8	Input/output terminals
18,19,21,22,23,25,26,27	S1~S8	Input/output terminals
5,9,12	COM1 ~ COMB	Common terminals
17,20,24	COM1 ~ COMB	Common terminals
13	ST	Strobe input terminal for data reading
15	C K	Clock input terminal for data transfer
16	DATA	Data input terminal for switch

IC BLOCK DIAGRAMS AND DESCRIPTIONS

TC74HCT7007AF(Hex buffer)

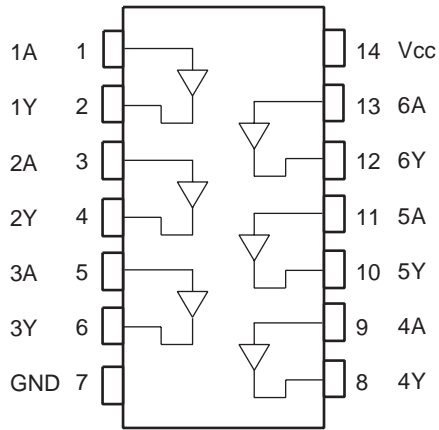

(TOP VIEW)

Truth table

A	Y
L	L
H	H

TC74VHC541FT(Octal bus buffer)

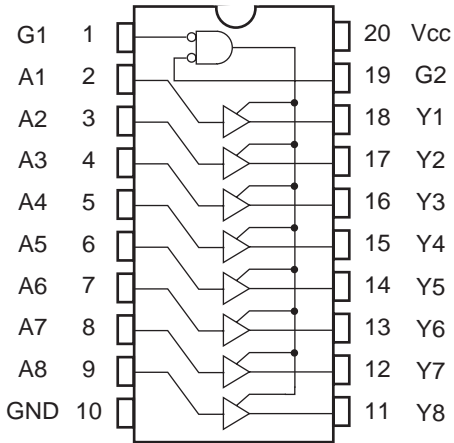

INPUTS			OUTPUT
$\overline{G1}$	$\overline{G2}$	A_n	
H	X	X	Z
X	H	X	Z
L	L	H	H
L	L	L	L

X :Don't care
Z :High impedance

74HCU04F(Hex Inverters)

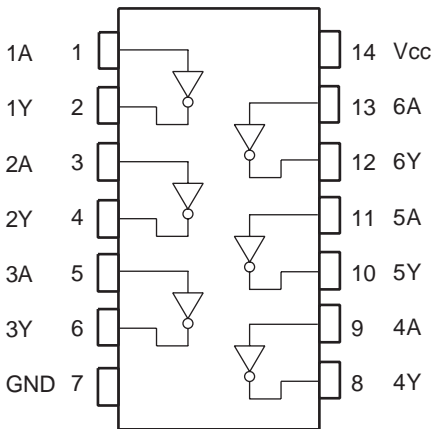

(TOP VIEW)

Truth table

A	Y
L	H
H	L

MICROPROCESSOR-CONNECTION DIAGRAM

1

2

3

4

5

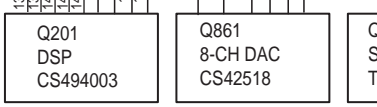
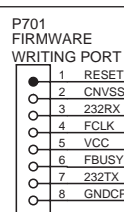
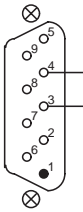
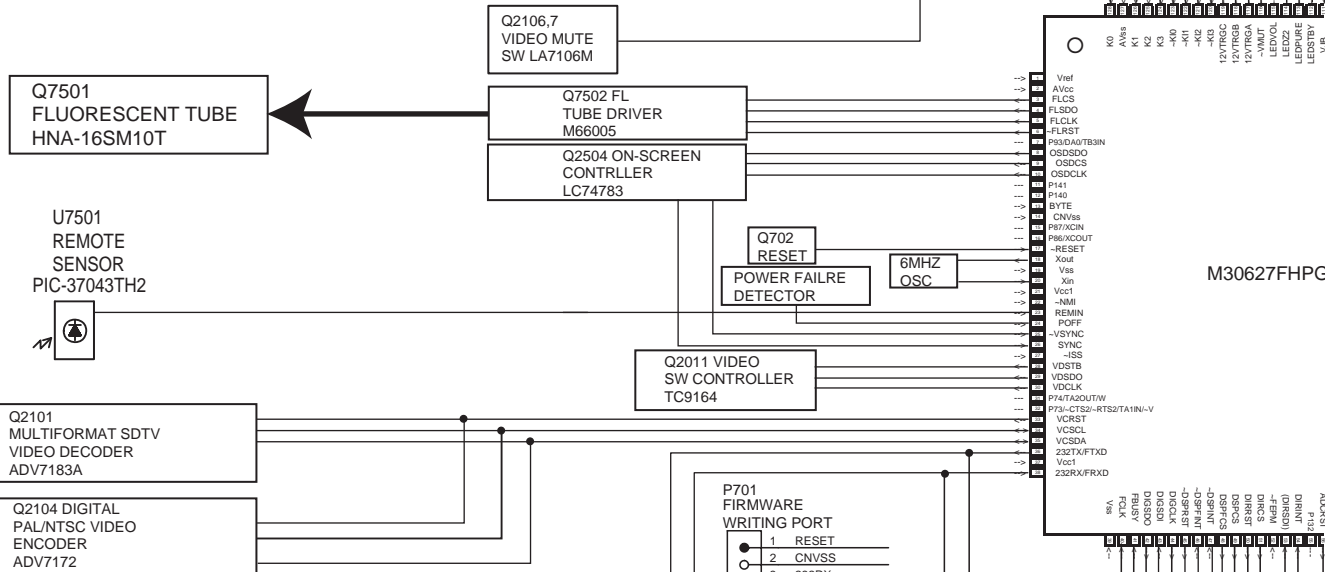
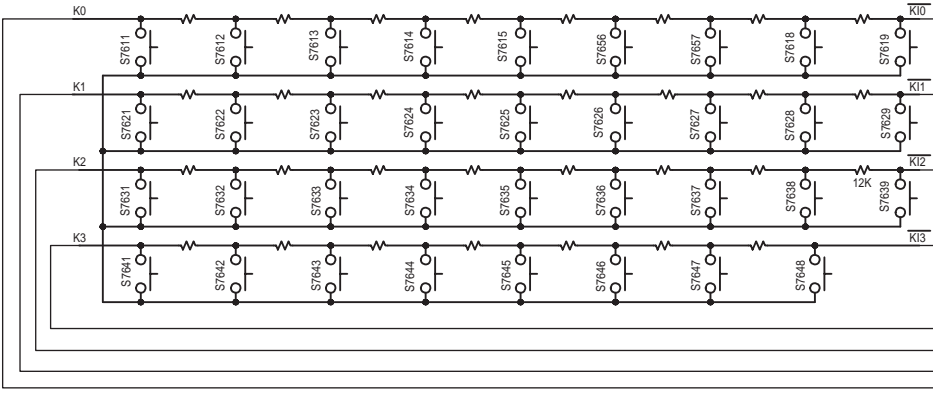
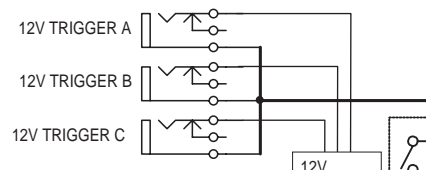

MICROPROCESSOR-CONNECTION DIAGRAM

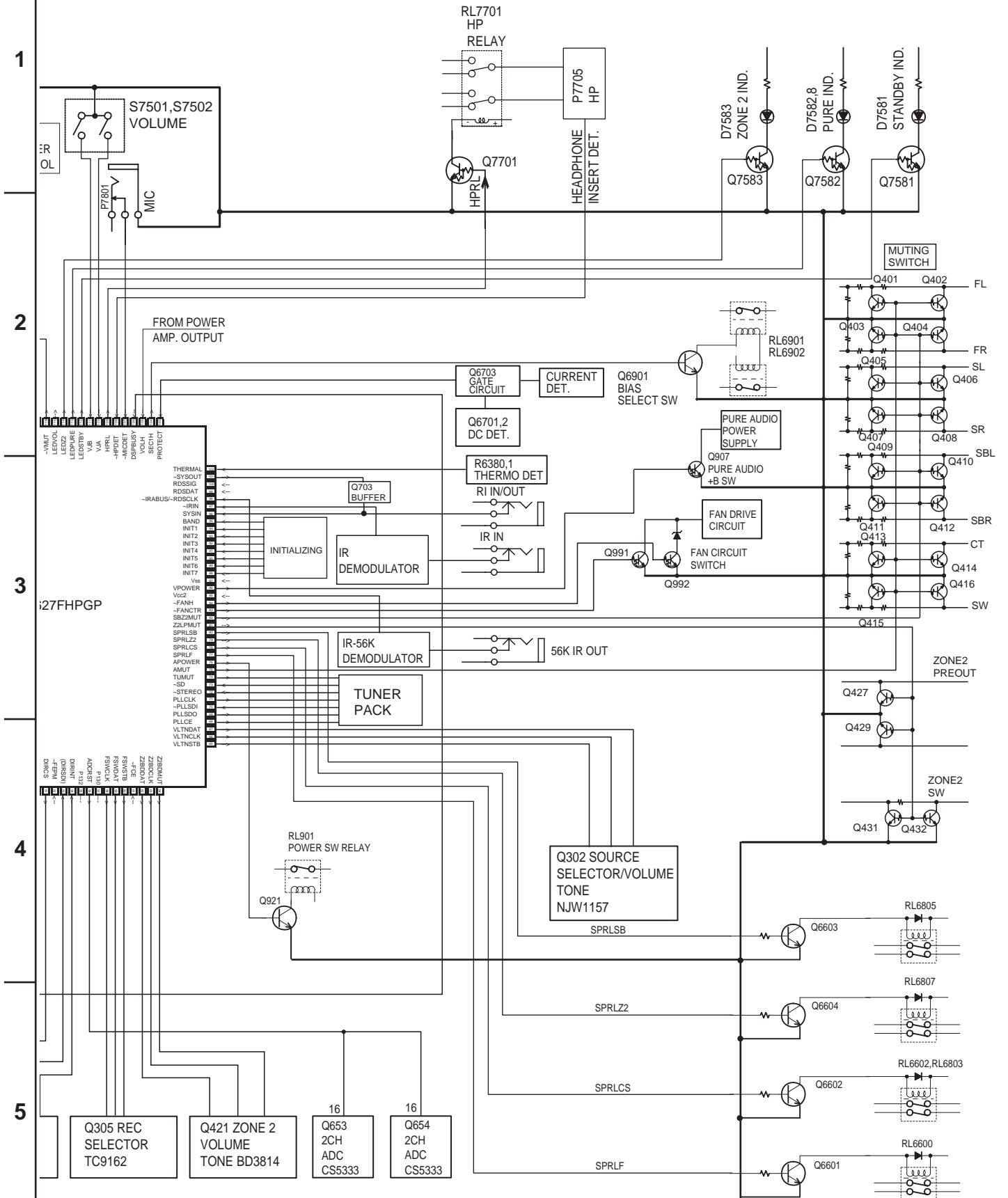

MICROPROCESSOR-TERMINAL DESCRIPTIONS

No.	Terminal	Symbol	I/O	Act.	Description
1	Vref	Vref	I		Connect to Vcc. Reference voltage input terminal for A/D converter.
2	AVcc	AVcc	I		Connect to Vcc. Power supply terminal for A/D converter.
3	P97/~ADTRG/SIN4	FLCS	O	L	Chip selector output terminal for FL tube driver
4	P96/ANEX1/SOUT4	FLSDO	O	H	Data output terminal for FL tube driver
5	P95/ANEX0/CLK4	FLCLK	O	CLK	Clock output terminal for FL tube driver
6	P94/DA1/TB4IN	~FLRST	O	L	Reset signal output terminal for FL tube driver
7	P93/DA0/TB3IN				
8	P92/TB2IN/SOUT3	OSDSO	O	H	Data output terminal for on-screen display IC
9	P91/TB1IN/SIN3	OSDCS	O	H	Chip select output terminal for on-screen display IC
10	P90/TB0IN/CLK3	OSDCLK	O	CLK	Clock output terminal for on-screen display IC
11	P141				
12	P140				
13	BYTE	BYTE	I		Connect to Vss. Change over input terminal of external data bus width.
14	CNVss	CNVss	I		Connect to Vss via a resistor. Change over terminal of processor mode.
15	P87/XCIN				
16	P86/XCOUT				
17	~RESET	~RESET	I		Reset signal input terminal for microprocessor.
18	Xout	Xout	O		Oscillation circuit output terminal of main clock.
19	Vss	Vss	I		Connect to a ground terminal.
20	Xin	Xin	I		Oscillation circuit input terminal for main clock
21	Vcc1	Vcc1	I		2.7V<Vcc2≤Vcc1<5.5V
22	P85/~NMI	~NMI	I	L	Connect to Vcc via a resistor.
23	P84/~INT2	REMIN	I	L	Remote control signal input terminal
24	P83/~INT1	POFF	I	L	Power failure detection input terminal
25	P82/~INT0	~VSYNC	I	L	Vertical synchronization detection input terminal
26	P81/TA4IN/~U	SYNC	I	H	Synchronization detection input terminal
27	P80/TA4OUT/U	~ISS	I	L	
28	P77/TA3IN	VDSTB	O	H	Strobe signal output terminal for video switch
29	P76/TA3OUT	VDSO	O	H	Data output terminal for video switch
30	P75/TA2IN/~W	VDCLK	O	CLK	Clock output terminal for video switch
31	P74/TA2OUT/W				
32	P73/~CTS2/~RTS2/TA1IN/~V				
33	P72/CLK2/TA1OUT/V	VCRST	O	H	Reset signal output terminal for Y/C separation and video converter ICs.
34	P71/RXD2/SCL2/TA0IN/TB5IN	VCSCS	I/O	H	Clock signal input/output terminal for Y/C separation and video converter ICs.
35	P70/TXD2/SDA2/TA0OUT	VCSDA	I/O	H	Data input/output terminal for Y/C separation and video converter ICs.
36	P67/TXD1/SDA1	232TX/FTXD	O	H	Data transfer terminal for RS-232C and flash writer.
37	Vcc1	Vcc1	I		2.7V<Vcc2≤Vcc1<5.5V
38	P66/RXD1/SCL1	232RX/FRXD	I	H	Data received terminal for RS-232C and flash writer.
39	Vss	Vss	I		Connect to ground terminal.
40	P65/CLK1	FCLK	I	CLK	Clock input terminal for flash writer
41	P64/~CTS1/~RTS1/~CTS0/CLKS1	FBUSY	I	H	Busy terminal for flash writer
42	P63/TXD0/SDA0	DIGSDO	O	H	Common data output terminal for digital section
43	P62/RXD0/SCL0	DIGSDI	I	H	Data input terminal from DSP IC
44	P61/CLK0	DIGCLK	O	CLK	Common clock output terminal for digital section
45	P60/~CTS0/~RTS0	~DSPRST	O	L	Reset signal output terminal for DSDP IC
46	P137	~DSPFINT	I	H	Input terminal to inform the status change of DSP IC.
47	P136	~DSPINT	I	H	Input terminal to inform the status change of DSP IC.
48	P135	DSPFCS	O	H	Chip select output terminal of DSP IC
49	P134	DSPCS	O	H	Chip select output terminal of DSP IC
50	P57/~RDY/CLKOUT	DIRRST	O	L	Reset signal output terminal of DIR IC
51	P56/ALE	DIRCS	O	L	Chip select output terminal for DIR IC
52	P55/~HOLD	~FEPM	I	L	Connect to ground terminal via resistor. Setting terminal of flash writer.
53	P54/~HLDA	(DIRSDI)	I	H	Data input terminal of DIR IC
54	P133	DIRINT	I	H	Unlock detection terminal of DIR IC
55	P132				
56	P131	ADCRST	O	L	Reset input terminal for multi channel A/D converter
57	P130				
58	P53/BCLK	FSWCLK	O	CLK	Clock signal output terminal of function switch
59	P52/~RD	FSWDAT	O	H	Data output terminal of function switch
60	P51/~WRH/~BHE	FSWSTB	O	H	Strobe signal output terminal of function switch
61	P50/~WRL/~WR	~FCE	I	L	Connect to Vcc2 terminal via resistor. Setting terminal of flash writer.
62	P127	Z2BDDAT	O	H	Data output terminal to volume and tone control IC for zone 2.
63	P126	Z2BDCLK	O	H	Clock output terminal to volume and tone control IC for zone 2.
64	P125	Z2BDMUT	O	H	Muting signal output terminal to volume and tone control IC for zone 2.

MICROPROCESSOR-TERMINAL DESCRIPTIONS

No.	Terminal	Symbol	I/O	Act.	Description
65	P47/~CS3	VLTNSTB	O	H	Strobe signal output terminal for selector, volume and tone control IC.
66	P46/~CS2	VLTNCLK	O	CLK	Clock output terminal for selector, volume and tone control IC.
67	P45/~CS1	VLTN DAT	O	H	Data output terminal for selector, volume and tone control IC.
68	P44/~CS0	PLLCE	O	H	Chip enable out terminal for tuner unit
69	P43/A19	PLLSDO	O	H	Data output terminal for tuner unit
70	P42/A18	~PLLSDI	I	L	Data input terminal from tuner unit
71	P41/A17	PLLCLK	O	CLK	Clock output terminal for tuner unit
72	P40/A16	~STEREO	I	L	Stereo detection input terminal from tuner unit
73	P37/A15	~SD	I	L	broadcast detection input terminal from tuner unit
74	P36/A14	TUMUT	O	H	Mute control output terminal for tuner unit
75	P35/A13	AMUT	O	H	Muting control output terminal of audio section
76	P34/A12	APOWER	O	H	Power supply relay control output terminal
77	P33/A11	SPRLF	O	H	Speaker relay control output terminal of front channel
78	P32/A10	SPRLCS	O	H	Speaker relay control output terminal of center and surround channels
79	P31/A09	SPRLZ2	O	H	Speaker relay control output terminal of zone 2
80	P124	SPRLSB	O	H	Speaker relay control output terminal of surround back channel
81	P123	Z2LPMUT	O	H	Muting control output terminal of zone 2 and pre output terminal
82	P122	SBZ2MUT	O	H	Muting control output terminal of zone 2 and surround back channels.
83	P121	~FANCTR	O	L	Lower speed or off setting output terminal of fun
84	P120	~FANH	O	L	High speed setting output terminal of fun
85	Vcc2	Vcc2	I		Connect to $2.7V < Vcc2 \leq Vcc1 < 5.5V$
86	P30/A8(/-/D7)	VPOWER	O	H	Power supply control output terminal of video section
87	Vss	Vss	I		Connect to ground terminal
88	P27/AN27/A7(/D7/D6)	INIT7	I	A/D	Initializing terminal
89	P26/AN26/A6(/D6/D5)	INIT6	I	A/D	Initializing terminal
90	P25/AN25/A5(/D5/D4)	INIT5	I	A/D	Initializing terminal
91	P24/AN24/A4(/D4/D3)	INIT4	I	A/D	Initializing terminal
92	P23/AN23/A3(/D3/D2)	INIT3	I	A/D	Initializing terminal
93	P22/AN22/A2(/D2/D1)	INIT2	I	A/D	Initializing terminal
94	P21/AN21/A1(/D1/D0)	INIT1	I	A/D	Initializing terminal
95	P20/AN20/A0(/D0/-)	BAND	I	A/D	Band area setting input terminals of tuner section
96	P17/D15/~INT5	SYSIN	I	H	RI input terminal
97	P16/D14/~INT4	~IRIN	I	L	IOR IN input terminal
98	P15/D13/~INT3	~IRABUS	I	L	IR ABUS input terminal
99	P14/D12	RDSDAT	I	L	RDS IC data input terminal
100	P13/D11	RDSSIG	I	L	RDS IC demodulator signal input terminal
101	P12/D10	~SYSOUT	O	H	RI output terminal
102	P11/D9	THERMAL	I	H	Thermal detection input terminal
103	P10/D8	PROTECT	I	H	Voltage protect input terminal
104	P07/AN07/D7	SEC1H	O	H	Power amplifier voltage select terminal
105	P06/AN06/D6	VOLH	I	A/D	Power amplifier voltage detection input terminal
106	P05/AN05/D5	DSPBUSY	I	H	DSP BUSY signal detection terminal
107	P04/AN04/D4	~MICDET	I	L	Microphone signal detection input terminal
108	P03/AN03/D3	~HPDET	I	L	Headphone detection input terminal
109	P02/AN02/D2	HPRL	O	H	Headphone relay control output terminal
110	P01/AN01/D1	VJA	I	H	Rotary encoder input terminal for volume
111	P00/AN00/D0	VJB	I	H	Rotary encoder input terminal for volume
112	P117	LEDSTBY	O	L	STANDBY/RECV indicator control output terminal
113	P116	LEDPURE	O	H	PURE AUDIO indicator control output terminal
114	P115	LEDZ2	O	H	ZONE2 indicator control; output terminal
115	P114	LEDVOL	O	H	VOLUME control output terminal
116	P113	~VMUT	O	L	Muting control output terminal of video section
117	P112	12VTRGA	O	H	12V Trigger A control output terminal
118	P111	12VTRGB	O	H	12V Trigger B control output terminal
119	P110	12VTRGC	O	H	12V Trigger C/Z2 control output terminal
120	P107/AN7/~KI3	~KI3	I	L	Key input interrupter input terminal
121	P106/AN6/~KI2	~KI2	I	L	Key input interrupter input terminal
122	P105/AN5/~KI1	~KI1	I	L	Key input interrupter input terminal
123	P104/AN4/~KI0	~KI0	I	L	Key input interrupter input terminal
124	P103/AN3	K3	I	A/D	Key input terminal
125	P102/AN2	K2	I	A/D	Key input terminal
126	P101/AN1	K1	I	A/D	Key input terminal
127	AVss	AVss	I		Connect to Vss. Power supply terminal for A/D converter.
128	P100/AN0	K0	I	A/D	Key input terminal

ADJUSTMENT AND CONFIRMATION PROCEDURES

1. Idling current adjustment

Before Idling adjustment, turn the trimming resistors R6040 to R6045 counter-clockwise fully.

Connect the DC voltmeter to sockets P6080 to P6084.

After turn POWER to ON, adjust the trimming resistors R6040, R6041 and R6042 so that the reading of voltmeter becomes 1.25mV. (Front and center channels)

Adjust the trimming resistors R6043, and R6044 so that the reading of voltmeter becomes 0.75 mV. (Surround and surround back channels)

After adjustment, attach the top cover.

Confirm the voltage of points above after about five minutes.

Front and center channels

When less than 5.0 mV, readjust the resistors above so that the voltage becomes 5.0 mV.

When 5.0 mV to 6.0 mV, it is not necessary to adjust.

When more than 6.0 mV, readjust the resistors above so that the voltage becomes 6.0 mV.

Surround and surround back channels

When less than 3.5 mV, readjust the resistors above so that the voltage becomes 3.5 mV.

When 3.5 mV to 4.5 mV, it is not necessary to adjust.

When more than 4.5 mV, readjust the resistors above so that the voltage becomes 4.5 mV.

Note: No load and No signal

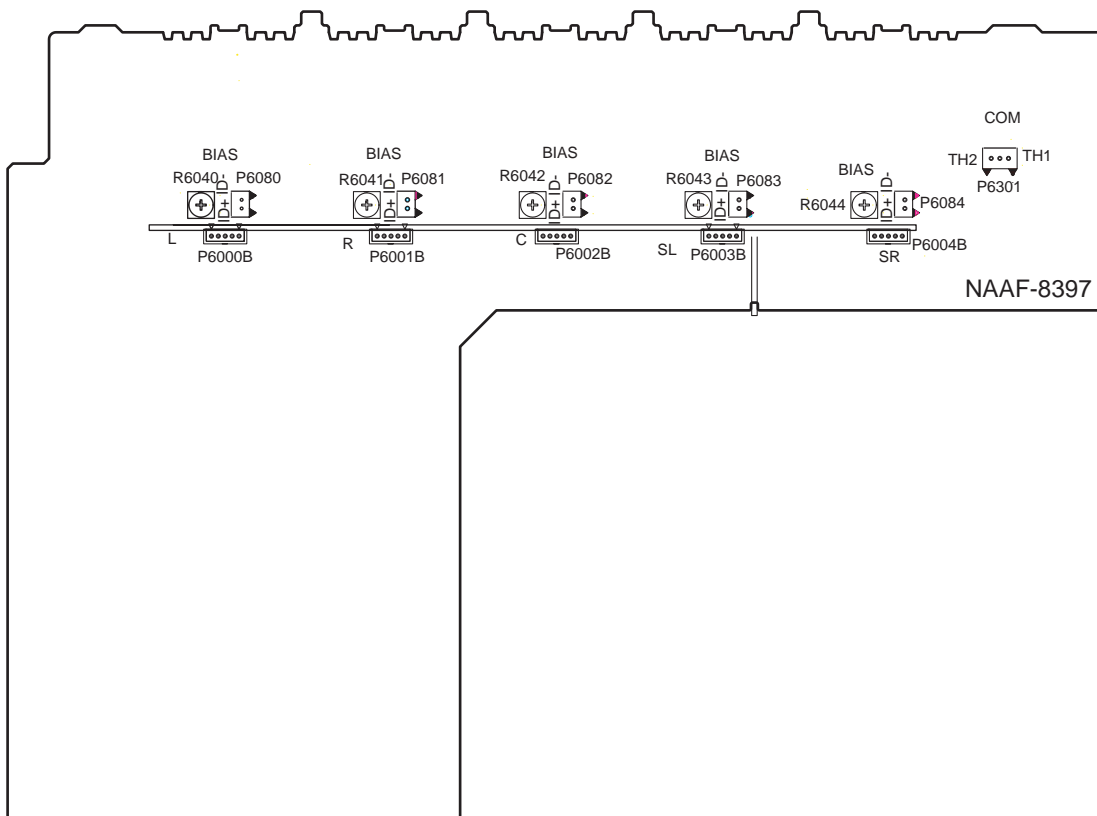

Confirmation of protection circuit

1. Confirmation of speaker relay

Confirm that the speaker relays turn ON approximately 5 seconds after the power switch is turned ON.
Confirm that the speaker relays turn OFF immediately after the power switch is turned OFF.

2. How to enter Test Mode

1. To enter a test mode (Test 1 to 4), when the unit is turned on, hold down "CD" + "DISPLAY" buttons and then press "STANDBY/ON" button.
2. Press the respective designated buttons and make sure that your target mode starts.

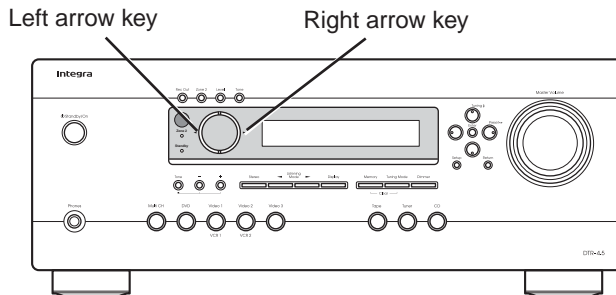

Mode	Button to be pressed	Message to be shown on the Front display
Test-1	"DVD"	"Test-1-00"
Test-2	"VIDEO 1"	"Test-2-00"
Test-3	"VIDEO 2"	"TUNER 82"
Test-4	"VIDEO 3"	"Test-4-00"

To move to the next step, press the right arrow key.

When you enter Test-3, it is necessary to press this button once to see "Test-3-00" is shown.

To move to the previous step, press the left arrow key.

To exit, press "STANDBY/ON" button.

3. Confirmation of protection circuit

Check of Voltage detection

1. Enter Test-4 mode.
2. Press and release the right arrow key repeatedly until "TEST-4-21" is shown on the Front display.
3. See your unit automatically start to check each channel.

During the check, the message on the display is changing as follows:

Channel	1st Message	2nd Message
FL+	TEST-4-21	Protect OK
FR-	TEST-4-22	Protect OK
C+	TEST-4-23	Protect OK
SL-	TEST-4-24	Protect OK
SR+	TEST-4-25	Protect OK
SBL-	TEST-4-26	Protect OK
SBR+	TEST-4-27	Protect OK

When the whole check is completed, "TEST-4-35" is shown.

4. Exit from the test mode.

Check of Current detection

1. Enter Test-4 mode.
2. Press and release the right arrow key repeatedly until "TEST-4-35" is shown on the Front display.
3. Connect a 3 ohm hollow resistor to a speaker terminal for each channel and make sure that the speaker relay would not cut off.
4. Connect a 1.5 ohm hollow resistor to a speaker terminal for each channel and make sure that the speaker relay would cut off.
5. Exit from the test mode.

4. Operation check of voltage sensor and thermal protector

1. Enter Test-4 mode.
2. Press and release the right arrow key repeatedly until "TEST-4-36" is shown on the front display.
3. Confirm that the FM STEREO indicator lights on and the relays of RL6901 and RL6902 turn OFF.
4. Press the right arrow key to set "TEST-4-37".
5. Confirm that the FM STEREO indicator lights on and the relays of RL6901 and RL6902 turn OFF.
6. Exit from the test mode.
7. Connect a metal oxide resistor 1.8 kohm/1W between "COM" and "TH2" terminals of P6302 with no input signal.
8. Set the unit to the test mode "TEST-1-00".
9. Confirm that "Thermal Protect" is displayed on the front display.

Test Mode of FL tube

To enter a test mode (Test 1 to 4), when the unit is turned on, hold down "CD" + "DISPLAY" buttons and then press "STANDBY/ON" button. After "TEST " on the FL tube is displayed, press CD button to set the unit to the test mode of FL tube.

Test mode of FL tube
 Right arrow key....UP
 Left arrow key.....DOWN

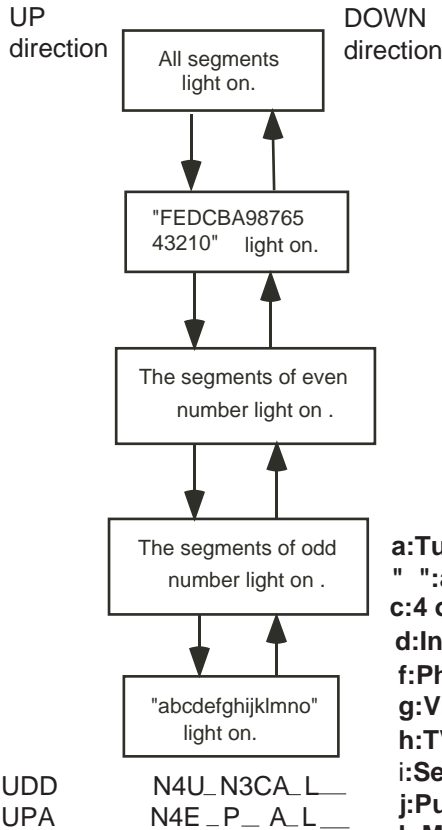

a:Tuner "U":USA and Canada "E":Europe "W":Worldwide "J":Japan
 " ":avaiable b:Amplifier ch, "5":5 ch "7":7 ch
 c:4 ohm correspondence "4":Yes "6":No
 d:Input numbers e:Front video: "F":Yes "N":No
 f:Phono: "P":avaiable
 g:Video converer function: "C":avaiable
 h:TV format function : "N":NTSC "P":PAL/NTSC
 i:Setup mic. function : "Y":avaiable
 j:Pure audio function : "P":avaiable
 k:Multi-ch. function "M":avaiable
 l: Zone 2 output function "L":LINE "P": LINE/Preout
 m12V trigger function:"Z":ZONE2 "A":A/B/C
 n:IR input function:"i":Yes o:RS232C function:"R":Yes
 Note: All functions " ": No avaiable

PACKING PROCEDURES

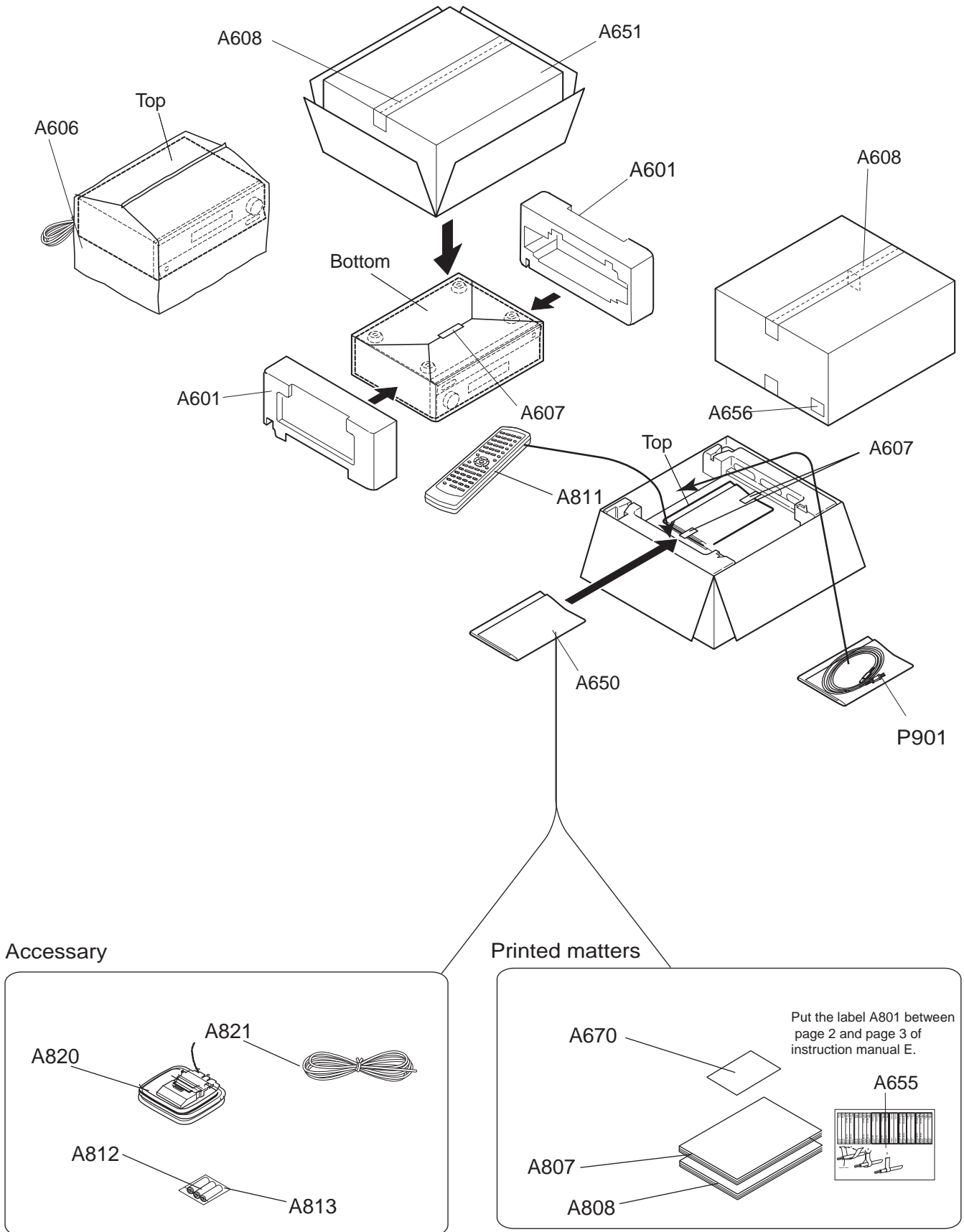

EXPLODED VIEW-PARTS LIST

NOTE: THE COMPONENTS IDENTIFIED BY MARK !
ARE CRITICAL FOR RISK OF FIRE AND
ELECTRIC SHOCK. REPLACE ONLY WITH
PART NUMBER SPECIFIED.

CAUTION: Replacement for transistor of mark *, if necessary
must be made from the same beta group (hFE) as
the original type.

REF. NO.	PART NO.	DESCRIPTION
A001	27111359	Front bracket
A002	28325756	Knob, standby
A006	28326235A	Knob, ring
A011	28192039	Clear plate, ring
A013	27212680	Front panel
A017	28135278	Badge
A018	801618	3TTB+8B(CU)SR,Self-tapping screw
A026	801618	3TTB+8B(CU)SR,Self-tapping screw
A027	27268128	Guide, volume
A029	838430088	3TTB+8B(BC),Self-tapping screw
A031	801618	3TTB+8B(CU)SR,Self-tapping screw
A033	27123334A	Rear panel
A036	27255004	CS-1U,Clip
A037	838430088	3TTB+8B(BC),Self-tapping screw
A038	27130973	Bracket PT-2
A041	27100451A	Chassis
A042	838440089	4TTB+8C(BC),Self-tapping screw
A043	28141620	Cushion
A045	29110083	Tape, cloth
A046	29363195	Label, hook-up Integra
A048	27190369	KGLS-22S,Holder
A050	28326231	Knob, volume
A056	27191112	KGPS-6RF,Holder
A060	27190926	KGPS-18RF,Holder
A066	27190965	Holder
A086	801618	3TTB+8B(CU)SR,Self-tapping screw
A091	27130970	Bracket PT
A096	27160559B	Heat sink
A121	801606	3SMH10W.SW+15B(CU),Special screw
A176	28192038A	Clear plate
A177	28133412	Back plate
A181	830440089	4TTC+8C(BC),Self-tapping screw
A192	260220	WS-3NS,Clamp
A206	28184903	Top cover
A211	838430088	3TTB+8B(BC),Self-tapping screw
A216	27175405	Leg
A221	28141599	Cushion
A226	801618	3TTB+8B(CU)SR,Self-tapping screw
A231	29363409-1	Label PT
A236	29362772	Label, cover
E800	260208	BSK-1,Wire tie
F6901,F6902	252301 or	! 12A-TUL-250V or
	252196	! 12A-UL/T-314,Fuse
F901	252198	! 8A-UL,Fuse
F903	252164 or	! 5A-UL/T-237 or
	252258	! 5A-T/UL-ST2,Fuse

REF. NO.	PART NO.	DESCRIPTION
F9501	252160 or 252254	! 2.5A-UL/T-237 or ! 2.5A-T/UL-ST2,Fuse
P6931	2045111012	NCFC5-111012,Flexible flat cable
P7501	2045235012	NCFC5-235012,Flexible flat cable
P7502	2047112012	NCFC7-112012,Flexible flat cable
P761	2047152512	NCFC7-152512,Flexible flat cable
Q6050,Q6051	2202843 or	* 2SC5242-O or
Q6052	2202842	* 2SC5242-R,Transistor
Q6050A	223024	AC238,Isolated plate
Q6053,Q6054	2203663 or	* MN130S-O or
	2203664 or	* MN130S-Y or
	2203666 or	* MN130S-P or
	2202843 or	* 2SC5242-O or
	2202842	* 2SC5242-R,Transistor
Q6060,Q6061	2202833 or	* 2SA1962-O or
Q6062	2202832	* 2SA1962-R,Transistor
Q6063,Q6064	2203673 or	* MP130S-O or
	2203674 or	* MP130S-Y or
	2203676 or	* MP130S-P or
	2202833 or	* 2SA1962-O or
	2202832	* 2SA1962-R,Transistor
T901	2301772	! NPT-1503D,Power transformer
U1	1B041565-1V	NAAR-8365-1V,DSP and main microprocessor PC board ass'y
U2	1B041566-1V	NADG-8366-1V,Main connector PC board ass'y
U3	1B041567-1V	NAETC-8367-1V,Control terminal PC board ass'y
U4	1B041568-1V	NADG-8368-1V,Digital input/output terminal PC board ass'y
U5	1B041582-2A	NAPS-8382-2A,Primary circuit PC board ass'y
U6	1B041583-2A	NAAF-8383-2A,Driver circuit PC board ass'y
U7	1B041584-2A	NAETC-8384-2A,Transformer terminal PC board ass'y
U11	1B041588-2A	NAETC-8388-2A,AC inlet terminal PC board ass'y
U12	1B041589-2A	NAPS-8389-2A,Secondary circuit PC board ass'y
U13	1B041590-2A	NAETC-8390-2A,Fuse terminal PC board ass'y
U16	1B041597-1V	NAAF-8397-1V,Power amplifier PC board ass'y
U17	1B041598-1V	NAETC-8398-1V,Secondary circuit PC board ass'y
U18	1B041599-1V	NAETC-8399-1V,Speaker terminal PC board ass'y
U19	1B041500-1V	NAETC-8400-1V,Speaker terminal F/C PC board ass'y
U21	1B041502-1V	NAETC-8402-1V,Thermal detector PC board ass'y
U22	1B041503-1V	NAETC-8403-1V,Holder PC board ass'y
U23	1B041504-1V	NAETC-8404-1V,PC board for cord clamp
U26	1B041506-1V	NADIS-8406-1V,Display circuit PC board ass'y
U27	1B041507-1V	NAVD-8407-1V,Video terminal PC board ass'y
U31	1B041511-1V	NASW-8411-1V,Volume PC board ass'y
U32	1B041512-1V	NAETC-8412-1V,Headphone terminal PC board ass'y
U36	240146 or	FAE385-A02F or
	240138A or	ENG06501QR or
	240134A	TFCE1U114B,Tuner unit

PACKING VIEW-PARTS LIST

REF. NO.	PART NO.	DESCRIPTION
A601	29092213A	Pad
A606	29100153	1020x770,Polybag
A607	29110149	Cellophane tape
A608	29110148	Tape PP
A650	29100097-1A	350*250,Polybag
A651	29054248	Carton box
A655	29363059A	Label, speaker cable
A656	29363890	Label UPC
A670	29365089A	Warranty card
A807	29343826	Instruction manual
A808	29355468	Instruction sheet, digest
A811	24140587	RC-587M,Remote controller
A812	3010054	R6/AA(UM-3),Three batteries
A813	29100217	t0.1*70*100,Polybag
A820	232140	NMA-3057,AM loop antenna
A821	292191	FM antenna
P901	253297KAW or !	AS-UC-2 or
	253352TES !	AS-UC-2,Power supply cord

PRINTED CIRCUIT BOARD-PARTS LIST

NOTE: THE COMPONENTS IDENTIFIED BY MARK !
ARE CRITICAL FOR RISK OF FIRE AND
ELECTRIC SHOCK. REPLACE ONLY WITH
PART NUMBER SPECIFIED.

CAUTION: Replacement for transistor of mark *, if necessary
must be made from the same beta group (h **FE**) as
the original type.

NOTE: <D>:120V model only <A>:Australian model only

DSP and preamplifier PC board (NAAR-8365-1V)

CIRCUIT NO.	PART NO.	DESCRIPTION
	ICs	
Q201	22242165R3	CS494003CQZ(CSSS)
Q202	22242123R3 or 22242152R2 or 22242123R2	IC42S16100 or K4S161622H-UC60 or IC42S16100
Q203	W0023R301386M100	MX29LV040TC-90
Q302	22242193R3	NJW1157B (After change)
Q303	222780073R2	78L07(SMT)
Q304	222790073R2	79L07(SMT)
Q305	22242099R2	TC9162BFG
Q306,Q307	22241383R2	NJM4565M-D
Q421	22242157R2	BD3814FV
Q501,Q502,Q503	22241383R2	NJM4565M-D
Q681	22274541ER2TO or 22274541IR2TI	TC74VHC541FT or SN74AHC541PWR
Q682	222740077R2TO	TC74HCT7007AF
Q861	22242168R3 or 22242168R2	CS42518-CQZR-C or CS42518-CQZR-C
Q862	22240935R2	TC7WU04FU
Q901	222780124TOS or 222780125	TA7812S or 78M12HF
Q902	222790124TOS or 222790125	TA79012S or 79M12HF
Q903	222780053R2JR	NJM78L05UA
Q910	222790054TOS or 222790055	TA79005S or 79M05FA
Q911	222780053R2JR	NJM78L05UA
Q921	22278033DR2JR or 22278033DR2NE	NJM2391DL1-33 or MPC2933T
Q922	22278025DR2JR or 22278025DR2NE	NJM2391DL1-25 or MPC2925T
	Transistors	
Q402,Q404	2215410R2	RN1441
Q406,Q408	2215410R2	RN1441
Q414,Q415,Q416	2215410R2	RN1441
Q427,Q429	2215410R2	RN1441
Q904,Q909	2202314	2SA1726-Y
	Diodes	
D861,D862,D863	223234R2 or	1SS352 or
D864,D865,D866	223269R2	1SS355
D867,D868,D901	223234R2 or	1SS352 or
D902	223269R2	1SS355
	Coils	
L201,L202	231237K022R2	NCH-1471
L203,L204,L205	233533M022R2 or	NCH-1587-022M or
L866	231237K022R2	NCH-1471
L211	230959R1	BK1608LL241-T
L861,L862	233533M022R2 or	NCH-1587-022M or
L863,L864	231237K022R2	NCH-1471
L865,L867,L868	230958R1	BK1608LM182-T

CIRCUIT NO.	PART NO.	DESCRIPTION
L921	233533K022R2 or 231237K022R2	NCH-1587-022K or NCH-1471
X801	Oscillator 3010324R2	CSTCV12.2MTJ0C4
	Capacitors	
C201	395640227R2	CS772SB1C-2.2M,Chip tantal
C202	347341224R2	CC732CH1H-122J,Chip ceramic
C203	342106804R1	CC725CH1H-680J1,Chip ceramic
C204,C205,C206	332161040R1	CK725F1E-104Z1,Chip ceramic
C207,C208,C209	332161040R1	CK725F1E-104Z1,Chip ceramic
C210,C211,C212	332161040R1	CK725F1E-104Z1,Chip ceramic
C213,C214,C215	332161040R1	CK725F1E-104Z1,Chip ceramic
C216	342101014R1	CC725CH1H-101J1,Chip ceramic
C217,C218,C281	394644707 or	CE04W16V-47M(VR) or
C291	394744707	CE04W16V47M(SC),Elect.
C219	394680107 or	CE04W50V-1M(VR) or
	394780107	CE04W50V1.0M(SC),Elect.
C282,C283,C284	332161040R1	CK725F1E-104Z1,Chip ceramic
C285,C286,C287	332161040R1	CK725F1E-104Z1,Chip ceramic
C292,C302	332161040R1	CK725F1E-104Z1,Chip ceramic
C303,C304,C305	332161040R1	CK725F1E-104Z1,Chip ceramic
C309,C310,C313	342102214R1	CC725CH1H-221J1,Chip ceramic
C314,C315,C316	342102214R1	CC725CH1H-221J1,Chip ceramic
C319,C320,C323	342102214R1	CC725CH1H-221J1,Chip ceramic
C324,C325,C326	342102214R1	CC725CH1H-221J1,Chip ceramic
C327,C328	342102214R1	CC725CH1H-221J1,Chip ceramic
C329,C330	342102214R1	CC725CH1H-221J1,Chip ceramic
C351,C352	332161040R1	CK725F1E-104Z1,Chip ceramic
C353,C354	394642217 or	CE04W16V-220M(VR) or
	394742217	CE04W16V220M(SC),Elect.
C355,C358	393380477	CE04W50V-4.7M(VX),Elect.
C356,C359	375522244	MMT50V-224J,Plastic
C357,C360	373044724R2	ECHU16V-472J,Chip film
C364,C365	332161040R1	CK725F1E-104Z1,Chip ceramic
C366,C367,C368	393344707	CE04W16V-47M(VX),Elect.
C369,C370,C371	393344707	CE04W16V-47M(VX),Elect.
C372,C373	393344707	CE04W16V-47M(VX),Elect.
C374,C375	393341007	CE04W16V-10M(VX),Elect.
C376,C377	394641007 or	CE04W16V-10M(VR) or
C378,C379	394741007	CE04W16V10M(SC),Elect.
C380	394680107 or	CE04W50V-1M(VR) or
	394780107	CE04W50V1M(SC),Elect.
C381,C382	342103304R1	CC725CH1H-330J1,Chip ceramic
C383,C384	394644707 or	CE04W16V-47M(VR) or
	394744707	CE04W16V47M(SC),Elect.
C388	393341007	CE04W16V-10M(VX),Elect.
C389	342102214R1	CC725CH1H-221J1,Chip ceramic
C390	373041034R2	ECHU16V-103J,Chip film
C391	375521034	MMT50V-103J,Plastic
C401,C402	393344707	CE04W16V-47M(VX),Elect.
C403,C404,C407	393344707	CE04W16V-47M(VX),Elect.
C408	393381007	CE04W50V-10M(VX),Elect.
C411,C412	393341007	CE04W16V-10M(VX),Elect.
C415,C416	373044724R2	ECHU16V-472J,Chip film
C417,C418	373041044R2	ECHU16V-104J,Chip film
C419,C420	373041044R2	ECHU16V-104J,Chip film
C421,C422,C423	393341007	CE04W16V-10M(VX),Elect.
C424,C425,C426	393341007	CE04W16V-10M(VX),Elect.
C427,C428	393341007	CE04W16V-10M(VX),Elect.
C431,C432	394644707 or	CE04W16V-47M(VR) or
	394744707	CE04W16V47M(SC),Elect.
C439,C440	393380477	CE04W50V-4.7M(VX),Elect.

CIRCUIT NO.	PART NO.	DESCRIPTION
C443,C444	342111024R1	CC725CH1E-102J1,Chip ceramic
C450	332161040R1	CK725F1E-104Z1,Chip ceramic
C501,C502,C503	373044724R2	ECHU16V-472J,Chip film
Capacitors		
C504	374723334	ECQ-V50V-333J,Plastic
C505,C506	373044724R2	ECHU16V-472J,Chip film
C509,C510,C511	342106814R1	CC725CH1H-681J1,Chip ceramic
C513,C514	342106814R1	CC725CH1H-681J1,Chip ceramic
C517,C518,C519	342106814R1	CC725CH1H-681J1,Chip ceramic
C521,C522	342106814R1	CC725CH1H-681J1,Chip ceramic
C541,C542	394642217 or 394742217	CE04W16V-220M(VR) or CE04W16V220M(SC),Elect.
C543,C544	374721534	ECQ-B50V-153J,Plastic
C681,C682	332161040R1	CK725F1E-104Z1,Chip ceramic
C861,C862	393341007	CE04W16V-10M(VX),Elect.
C863,C864	393341007	CE04W16V-10M(VX),Elect.
C865,C866	373022224R2	ECHU50V-222J,Chip film
C867	394642217	CE04W16V-220M(VR),Elect.
C868,C869,C871	332161040R1	CK725F1E-104Z1,Chip ceramic
C870	395954707	CE04W25V-47M(RFS),Elect.
C872	394621017	CE04W6.3V-100M(VR),Elect.
C874	394642217	CE04W16V-220M(VR),Elect.
C875	332102225R1	CK725B1H-222K1,Chip ceramic
C876	332104735R1	CK725B1H-473K1,Chip ceramic
C877,C888,C889	332161040R1	CK725F1E-104Z1,Chip ceramic
C878	394621017	CE04W6.3V-100M(VR),Elect.
C879	332161040R1	CK725F1E-104Z1,Chip ceramic
C880,C881,C882	342103304R1	CC725CH1H-330J1,Chip ceramic
C883	342103304R1	CC725CH1H-330J1,Chip ceramic
C901	332152230R1	CK725F1H-223Z1,Chip ceramic
C902	394662207 or 394762207	CE04W35V-22M(VR) or CE04W35V22M(SC),Elect.
C904,C905,C907	394641007 or	CE04W16V-10M(VR) or
C911,C912	394741007	CE04W16V10M(SC),Elect.
C906,C908	332161040R1	CK725F1E-104Z1,Chip ceramic
C909	394681007 or 394781007 or 393381007	CE04W50V-10M(VR) or CE04W50V10M(SC) or CE04W50V-10M(VX),Elect.
C921,C923,C924	394644707 or 394744707	CE04W16V-47M(VR) or CE04W16V47M(SC),Elect.
R887	332121045R1	CK725B1C-104K1,Chip ceramic
Resistors		
R201,R202	435033324R1	RN72K1J-332JE,Chip carbon
R203,R204,R205	435032214R1	RN72K1J-221JE,Chip carbon
R206,R207,R208	435032214R1	RN72K1J-221JE,Chip carbon
R209,R210,R211	435033324R1	RN72K1J-332JE,Chip carbon
R212,R213	435033324R1	RN72K1J-332JE,Chip carbon
R214,R215	435032214R1	RN72K1J-221JE,Chip carbon
R217,R218	435032214R1	RN72K1J-221JE,Chip carbon
R219	435033324R1	RN72K1J-332JE,Chip carbon
R221,R222,R223	435034704R1	RN72K1J-470JE,Chip carbon
R224,R225,R226	435034704R1	RN72K1J-470JE,Chip carbon
R227,R228	435034704R1	RN72K1J-470JE,Chip carbon
R229	435031034R1	RN72K1J-103JE,Chip carbon
R230,R231,R232	435034704R1	RN72K1J-470JE,Chip carbon
R233,R234,R235	435034704R1	RN72K1J-470JE,Chip carbon
R236,R237,R238	435034704R1	RN72K1J-470JE,Chip carbon
R239,R240	435034704R1	RN72K1J-470JE,Chip carbon
R241,R242	435034704R1	RN72K1J-470JE,Chip carbon
R243,R244	435030004R1	RN72K1J-000JE,Chip carbon
R249	435033314R1	RN72K1J-331JE,Chip carbon
R250	435032724R1	RN72K1J-272JE,Chip carbon

CIRCUIT NO.	PART NO.	DESCRIPTION
R251,R252,R253	435031034R1	RN72K1J-103JE,Chip carbon
R254,R255,R256	435031034R1	RN72K1J-103JE,Chip carbon
R257,R258,R259	435031034R1	RN72K1J-103JE,Chip carbon
R260,R261,R262	435031034R1	RN72K1J-103JE,Chip carbon
Resistors		
R263,R264,R265	435031034R1	RN72K1J-103JE,Chip carbon
R266,R267,R268	435031034R1	RN72K1J-103JE,Chip carbon
R269,R270,R271	435031034R1	RN72K1J-103JE,Chip carbon
R272,R273,R274	435031034R1	RN72K1J-103JE,Chip carbon
R275,R276,R277	435031034R1	RN72K1J-103JE,Chip carbon
R278	435032214R1	RN72K1J-221JE,Chip carbon
R279	435034704R1	RN72K1J-470JE,Chip carbon
R281	435031034R1	RN72K1J-103JE,Chip carbon
R291,R292	435032214R1	RN72K1J-221JE,Chip carbon
R303,R304,R305	435033314R1	RN72K1J-331JE,Chip carbon
R306,R307,R308	435033314R1	RN72K1J-331JE,Chip carbon
R309,R310,R311	435033314R1	RN72K1J-331JE,Chip carbon
R312,R313,R314	435033314R1	RN72K1J-331JE,Chip carbon
R315,R316,R317	435033314R1	RN72K1J-331JE,Chip carbon
R318,R319,R320	435033314R1	RN72K1J-331JE,Chip carbon
R321,R322,R323	435033314R1	RN72K1J-331JE,Chip carbon
R324	435033314R1	RN72K1J-331JE,Chip carbon
R329,R330,R335	435035634R1	RN72K1J-563JE,Chip carbon
R336,R339,R340	435035634R1	RN72K1J-563JE,Chip carbon
R345,R346,R347	435035634R1	RN72K1J-563JE,Chip carbon
R348	435035634R1	RN72K1J-563JE,Chip carbon
R349,R350	435033314R1	RN72K1J-331JE,Chip carbon
R371,R372	435031224R1	RN72K1J-122JE,Chip carbon
R373,R374	435034714R1	RN72K1J-471JE,Chip carbon
R375,R376,377	435031034R1	RN72K1J-103JE,Chip carbon
R378,R379,R380	435031034R1	RN72K1J-103JE,Chip carbon
R385	435034734R1	RN72K1J-473JE,Chip carbon
R386	435031224R1	RN72K1J-122JE,Chip carbon
R387	435031534R1	RN72K1J-153JE,Chip carbon
R388	435031034R1	RN72K1J-103JE,Chip carbon
R401,R402,R403	435032224R1	RN72K1J-222JE,Chip carbon
R404,R407	435032224R1	RN72K1J-222JE,Chip carbon
R408	435032714R1	RN72K1J-271JE,Chip carbon
R409,R410,R411	435031014R1	RN72K1J-101JE,Chip carbon
R412,R415,R416	435031014R1	RN72K1J-101JE,Chip carbon
R417,R418,R419	435032234R1	RN72K1J-223JE,Chip carbon
R420,R423	435032234R1	RN72K1J-223JE,Chip carbon
R426	435030004R1	RN72K1J-000JE,Chip carbon
R427,R428	435031044R1	RN72K1J-104JE,Chip carbon
R441,R442,R443	435030004R1	RN72K1J-000JE,Chip carbon
R444,R445	435030004R1	RN72K1J-000JE,Chip carbon
R446,R447,R448	435030004R1	RN72K1J-000JE,Chip carbon
R451,R452	435034724R1	RN72K1J-472JE,Chip carbon
R459,R460	435030004R1	RN72K1J-000JE,Chip carbon
R479,R480	435030004R1	RN72K1J-000JE,Chip carbon
R485,R486	435032224R1	RN72K1J-222JE,Chip carbon
R487,R488	435032234R1	RN72K1J-223JE,Chip carbon
R498	435031044R1	RN72K1J-104JE,Chip carbon
R499	435033314R1	RN72K1J-331JE,Chip carbon
R501,R502,R503	435033324R1	RN72K1J-332JE,Chip carbon
R504,R505,R506	435033324R1	RN72K1J-332JE,Chip carbon
R509,R510,R511	435033324R1	RN72K1J-332JE,Chip carbon
R512,R513,R514	435033324R1	RN72K1J-332JE,Chip carbon
R517,R518,R519	435034714R1	RN72K1J-471JE,Chip carbon
R520,R521,R522	435034714R1	RN72K1J-471JE,Chip carbon
R525,R526,R527	435034714R1	RN72K1J-471JE,Chip carbon
R528,R529,R530	435034714R1	RN72K1J-471JE,Chip carbon

CIRCUIT NO.	PART NO.	DESCRIPTION
R533,R534,R535	435034724R1	RN72K1J-472JE,Chip carbon
R536,R537,R538	435034724R1	RN72K1J-472JE,Chip carbon
R541,R542,R543	435034724R1	RN72K1J-472JE,Chip carbon
R544,R545,R546	435034724R1	RN72K1J-472JE,Chip carbon
R549,R550, R551	435031814R1	RN72K1J-181JE,Chip carbon
Resistors		
R552	435034724R1	RN72K1J-472JE,Chip carbon
R553,R554	435031814R1	RN72K1J-181JE,Chip carbon
R557,R558,R559	435031814R1	RN72K1J-181JE,Chip carbon
R560	435034724R1	RN72K1J-472JE,Chip carbon
R561,R562	435031814R1	RN72K1J-181JE,Chip carbon
R637,R638,R639	435030004R1	RN72K1J-000JE,Chip carbon
R640,R641,R642	435030004R1	RN72K1J-000JE,Chip carbon
R682,R683,R684	435032214R1	RN72K1J-221JE,Chip carbon
R685,R686	435032214R1	RN72K1J-221JE,Chip carbon
R688,R689,R690	435032214R1	RN72K1J-221JE,Chip carbon
R691,R692,R693	435032214R1	RN72K1J-221JE,Chip carbon
R859	435031034R1	RN72K1J-103JE,Chip carbon
R861,R862	435035604R1	RN72K1J-560JE,Chip carbon
R863,R864	435035604R1	RN72K1J-560JE,Chip carbon
R865,R866	435033924R1	RN72K1J-392JE,Chip carbon
R867	435033314R1	RN72K1J-331JE,Chip carbon
R868	435032724R1	RN72K1J-272JE,Chip carbon
R869,R870,R871	435035604R1	RN72K1J-560JE,Chip carbon
R872,R873,R874	435035604R1	RN72K1J-560JE,Chip carbon
R875,R876,R877	435035604R1	RN72K1J-560JE,Chip carbon
R878,R879	435035604R1	RN72K1J-560JE,Chip carbon
R880,R881	435031024R1	RN72K1J-102JE,Chip carbon
R882	435032224R1	RN72K1J-222JE,Chip carbon
R883,R884	435031024R1	RN72K1J-102JE,Chip carbon
R885,R886	435035604R1	RN72K1J-560JE,Chip carbon
R888,R889	435033314R1	RN72K1J-331JE,Chip carbon
R890,R891	435033314R1	RN72K1J-331JE,Chip carbon
R897,R898,R900	435030004R1	RN72K1J-000JE,Chip carbon
R899	435031054R1	RN72K1J-105JE,Chip carbon
R901	441721204F	RS2WBJ-12,Metal oxide
R902	441725604F	RS2WBJ-56,Metal oxide
R904,R913	435033304R1	RN72K1J-330JE,Chip carbon
R906	441721014F	RS2WBJ-100,Metal oxide
R911,R912	435030004R1	RN72K1J-000JE,Chip carbon
Terminals		
P302	25045491	NPJ-4PDBL308
P303,P304	25045565	NPJ-6PDBL380
P305	25045734	NPJ-6PDWRLEGP522
P422	25045424	NPJ-2PDBL249
P424	25045696	LGY2502-0200C
Sockets		
JL9502B	25050271	NSCT-7P99
P308	2009990919UL	NSAS-24P1448
P6931B	25052577R2	NSCT-11P2474
Plugs		
P351A	25055709	NPLG-13P665
P352A	25055712	NPLG-20P668
P353A	25055807	NPLG-18P763
P354A	25055710	NPLG-14P666
Isolated sheets		
Q904B,Q909B	223026	ISO SHEET
Transistor accessory		
Q904C,Q909C	223034	MT-25
Heat sink		
Q901B	27160500	RAD-165
Screws		

Q901A,Q904A	82143010	3P+10FN(BC),Pan head
Q909A,Q910A	82143010	3P+10FN(BC),Pan head

Main connector PC board (NADG-8366-1V)

CIRCUIT NO.	PART NO.	DESCRIPTION
	ICs	
Q701	W0025R301150M105	M30627FHPGP U5C
	Transistors	
Q702,Q705,Q707	2216210R2 or	KRC104S or
Q709,Q711	2214490R2	RN1404
Q703,Q704	2216220R2 or	KRA102S or
Q706,Q708	2214530R2	RN2402
	Diodes	
D701,D702,D703	223234R2 or	1SS352 or
	223269R2	1SS355
D704,D707	224660514R2 or	HZU5.1B or
D709	224550510R2	UDZS5.1B
D705,D706,D708	223234R2 or	1SS352 or
	223269R2	1SS355
D711	224551300R2 or	UDZS13B or
	224661304R2	HZU13B
	Oscillator	
X701	3010397R2	CSTCR6M0055-R0
	Choke coil	
L701	233533K470R2 or	NCH-1587-470K or
	231237K470R2	NCH-1479
	Capacitors	
C701,C702,C703	394680107 or	CE04W50V-1M(VR) or
	394780107	CE04W50V1.0M(SC),Elect.
C704	3000126 or	FM0H224Z or
	3000079	DX-5R5L224,Super
C705	332121045R1	CK725B1C-104K1,Chip ceramic
C706	332161040R1	CK725F1E-104Z1,Chip ceramic
C707	394680107 or	CE04W50V-1M(VR) or
	394780107	CE04W50V1.0M(SC),Elect.
C708,C709,C710	332161040R1	CK725F1E-104Z1,Chip ceramic
C711,C712	332161040R1	CK725F1E-104Z1,Chip ceramic
C714,C715,C716	342111024R1	CC725CH1E-102J1,Chip ceramic
C717,C718,C719	342111024R1	CC725CH1E-102J1,Chip ceramic
C720,C721,C722	342111024R1	CC725CH1E-102J1,Chip ceramic
C723,C724	342111024R1	CC725CH1E-102J1,Chip ceramic
C725,C727	394641007 or	CE04W16V-10M(VR) or
C729,C741	394741007	CE04W16V10M(SC),Elect.
C726,C728	337394745R1	CK732B1C-474K,Chip ceramic
C737,C738	394680337 or	CE04W50V-3.3M(VR) or
	394780337	CE04W50V3.3M(SC),Elect.
C739,C740	342101014R1	CC725CH1H-101J1,Chip ceramic
	Resistors	
R701,R702	435032214R1	RN72K1J-221JE,Chip carbon
R703,R704	435032214R1	RN72K1J-221JE,Chip carbon
R705,R709,R710	435031034R1	RN72K1J-103JE,Chip carbon
R706,R707,R708	435032214R1	RN72K1J-221JE,Chip carbon
R711,R712,R713	435031034R1	RN72K1J-103JE,Chip carbon
R714,R715,R716	435032214R1	RN72K1J-221JE,Chip carbon
R717,R718,R719	435032214R1	RN72K1J-221JE,Chip carbon
R720,R721,R724	435032214R1	RN72K1J-221JE,Chip carbon
R722,R723	435031034R1	RN72K1J-103JE,Chip carbon
R725,R726	435031004R1	RN72K1J-100JE,Chip carbon
R727,R728,R729	435032214R1	RN72K1J-221JE,Chip carbon
R730,R731,R732	435032214R1	RN72K1J-221JE,Chip carbon

CIRCUIT NO.	PART NO.	DESCRIPTION
R733,R734,R735	435032214R1	RN72K1J-221JE,Chip carbon
R736,R737,R738	435032214R1	RN72K1J-221JE,Chip carbon
R739,R740,R741	435032214R1	RN72K1J-221JE,Chip carbon
R742,R743,R744	435032214R1	RN72K1J-221JE,Chip carbon
R745,R746	435031034R1	RN72K1J-103JE,Chip carbon
R747,R748	435032214R1	RN72K1J-221JE,Chip carbon
R749,R750	435032214R1	RN72K1J-221JE,Chip carbon
Resistors		
R751,R752,R753	435032214R1	RN72K1J-221JE,Chip carbon
R754,R755,R756	435032214R1	RN72K1J-221JE,Chip carbon
R757,R758,R759	435032214R1	RN72K1J-221JE,Chip carbon
R760,R761	435032214R1	RN72K1J-221JE,Chip carbon
R762,R763	435032214R1	RN72K1J-221JE,Chip carbon
R764,R770,R771	435030004R1	RN72K1J-000JE,Chip carbon
R765,R766,R767	435032214R1	RN72K1J-221JE,Chip carbon
R768,R769	435032214R1	RN72K1J-221JE,Chip carbon
R772,R773,R774	435032214R1	RN72K1J-221JE,Chip carbon
R775,R776,R777	435032214R1	RN72K1J-221JE,Chip carbon
R778,R779,R780	435032214R1	RN72K1J-221JE,Chip carbon
R781,R782,R783	435032214R1	RN72K1J-221JE,Chip carbon
R784	435034724R1	RN72K1J-472JE,Chip carbon
R785,R786,R787	435032214R1	RN72K1J-221JE,Chip carbon
R788,R789,R790	435032214R1	RN72K1J-221JE,Chip carbon
R791,R792,R793	435032214R1	RN72K1J-221JE,Chip carbon
R794,R795,R796	435032214R1	RN72K1J-221JE,Chip carbon
R797,R798,R799	435034724R1	RN72K1J-472JE,Chip carbon
R800,R801,R802	435034724R1	RN72K1J-472JE,Chip carbon
R803,R804,R833	435034724R1	RN72K1J-472JE,Chip carbon
R805,R806,R809	435031034R1	RN72K1J-103JE,Chip carbon
R810,R815	435034734R1	RN72K1J-473JE,Chip carbon
R811	435031054R1	RN72K1J-105JE,Chip carbon
R812,R813	435031024R1	RN72K1J-102JE,Chip carbon
R814,R816,R817	435031034R1	RN72K1J-103JE,Chip carbon
R818,R819,R820	435031034R1	RN72K1J-103JE,Chip carbon
R821,R822,R823	435031034R1	RN72K1J-103JE,Chip carbon
R824,R825,R526	435031034R1	RN72K1J-103JE,Chip carbon
R830,R860	435031034R1	RN72K1J-103JE,Chip carbon
R831	435032244R1	RN72K1J-224JE,Chip carbon
R832	435031014R1	RN72K1J-101JE,Chip carbon
R834,R835,R836	435031034R1	RN72K1J-103JE,Chip carbon
R837,R838,R839	435032724R1	RN72K1J-272JE,Chip carbon
R840	435032724R1	RN72K1J-272JE,Chip carbon
R841,R843,R845	435032224R1	RN72K1J-222JE,Chip carbon
R842,R844,R846	435031024R1	RN72K1J-102JE,Chip carbon
R847,R848,R849	435032244R1	RN72K1J-224JE,Chip carbon
R851,R852,R853	435034734R1	RN72K1J-473JE,Chip carbon
R854,R856,R857	435034734R1	RN72K1J-473JE,Chip carbon
R855	435033314R1	RN72K1J-331JE,Chip carbon
R858	435031044R1	RN72K1J-104JE,Chip carbon
R982,R984,R986	435030004R1	RN72K1J-000JE,Chip carbon
R987	435035634R1	RN72K1J-563JE,Chip carbon
R988	435033334R1	RN72K1J-333JE,Chip carbon
R990,R992	435030004R1	RN72K1J-000JE,Chip carbon
R993,R995	435031034R1	RN72K1J-103JE,Chip carbon
Sockets		
P103A	200AA390815UL	NSAS-8P0834
P351	25051238	NSCT-13P1028
P352	25051241	NSCT-20P1031
P353	25051529	NSCT-18P1316
P354	25051239	NSCT-14P1029
P7501B	25052589R2	NSCT-23P2486
P761A	25052211 or	NSCT-15P2108 or

	25051822	NSCT-15P1609
	Plugs	
P121A	25055711	NPLG-15P667
P2004A	25055710	NPLG-14P666
P2005A	25055705	NPLG-9P661
P701	25055704	NPLG-8P660

Control terminal PC board (NAETC-8367-1V)

CIRCUIT NO.	PART NO.	DESCRIPTION
	ICs	
Q133	22241383R2 or 22240581R2	NJM4565M-D or NJM4565M
Q151	222780053R2JR	NJM78L05UA
	Photo coupler	
Q177	24120080	PC817X
	Transistors	
Q131,Q132	2215410R2	RN1441
Q152,Q154,Q155	2216190R2 or 2214470R2	KRC102S or RN1402
Q153,Q156,Q157	2216175R2 or	KTC3875-GR or
Q158	2213145R2	2SC2712-GR
Q159	2216185R2 or 2214375R2	KTA1504-GR or 2SA1162-GR
Q171,Q172,Q173	2212855 or 2212853	2SB1068-U or 2SB1068-K
Q174,Q175,Q176 Q178,Q179	2216190R2 or 2214470R2	KRC102S or RN1402
	Diodes	
D131,D133	22380260 or 22380035	RL1N4003 or GP104003E
D132	223234R2 or 223269R2	1SS352 or 1SS355
	Capacitors	
C131,C132,C155	394641007 or 394741007	CE04W16V-10M(VR) or CE04W16V10M(SC),Elect.
C133,C134	393341007	CE04W16V-10M(VX),Elect.
C135,C136	393380227	CE04W50V-2.2M(VX),Elect.
C137,C138	342101014R1	CC725CH1H-101J1,Chip ceramic
C139,C140	342111024R1	CC725CH1E-102J1,Chip ceramic
C141,C142	393361007	CE04W35V-10M(VX),Elect.
C151	332112235R1	CK725B1E-223K1,Chip ceramic
C152,C153	342111024R1	CC725CH1E-102J1,Chip ceramic
C154	332161040R1	CK725F1E-104Z1,Chip ceramic
C156	332161040R1	CK725F1E-104Z1,Chip ceramic
C171,C172,C173	394644707 or 394744707	CE04W16V-47M(VR) or CE04W16V47M(SC),Elect.
C174,C175,C176	332101025R1	CK725B1H-102K1,Chip ceramic
C178	332112235R1	CK725B1E-223K1,Chip ceramic
C179	394621017 or 394721017	CE04W6.3V-100M(VR) or CE04W6.3V100M(SC),Elect.
	Resistors	
R131,R132	435032244R1	RN72K1J-224JE,Chip carbon
R133,R134,R189	435032234R1	RN72K1J-223JE,Chip carbon
R135,R136,R143	435032244R1	RN72K1J-224JE,Chip carbon
R137,R138	435036824R1	RN72K1J-682JE,Chip carbon
R139,R140	435036824R1	RN72K1J-682JE,Chip carbon
R141,R142	435033314R1	RN72K1J-331JE,Chip carbon
R151,R152	435033314R1	RN72K1J-331JE,Chip carbon
R153,R154,R158	435031024R1	RN72K1J-102JE,Chip carbon
R155,R156	435031034R1	RN72K1J-103JE,Chip carbon
R157	435033324R1	RN72K1J-332JE,Chip carbon
R160	435031234R1	RN72K1J-123JE,Chip carbon

R161,R162,R163	435031024R1	RN72K1J-102JE,Chip carbon
R164	435036814R1	RN72K1J-681JE,Chip carbon
R166	443524714	RS1/2WBJ-470,Metal oxide
R168	435032224R1	RN72K1J-222JE,Chip carbon
R169	435031024R1	RN72K1J-102JE,Chip carbon
R171,R172,R173	4000195	RXE030,Thermistor
R174,R175,R176	435032224R1	RN72K1J-222JE,Chip carbon
R177,R178,R179	435031024R1	RN72K1J-102JE,Chip carbon
R182,R184,R185	435030004R1	RN72K1J-000JE,Chip carbon
CIRCUIT NO.	PART NO.	DESCRIPTION
	Resistors	
R183	435031014R1	RN72K1J-101JE,Chip carbon
R188	435031034R1	RN72K1J-103JE,Chip carbon
R190	435033324R1	RN72K1J-332JE,Chip carbon
	Terminals	
P113	25045598	HEC0470-01-630
P115,P116	25045647	HSJ1002-01-1020
P117,P118	25045647	HSJ1002-01-1020
	Sockets	
P114	25052662	NSCT-8P2558
P121	25051240	NSCT-15P1030

Digital input/output terminal PC board (NADG-8368-1V)

CIRCUIT NO.	PART NO.	DESCRIPTION
	ICs	
Q101	22241537R2	MPD4721GS
Q111,Q112	222740046R2	74HCU04F
	Photo couplers	
U111	24120102	TOTX179L
U112,U113	24120101	TORX179L
	Coils	
L101	230948R2	BLM21A102F
L112,L113,L114	233533M022R2 or	NCH-1587-022M or
L115,L116	231237K022R2	NCH-1471
	Capacitors	
C102,C121	394621017 or 394721017	CE04W6.3V-100M(VR) or CE04W6.3V100M(SC),Elect.
C103	332161040R1	CK725F1E-104Z1,Chip ceramic
C104,C105,C106	394680107 or	CE04W50V-1M(VR) or
C107	394780107	CE04W50V1.0M(SC),Elect.
C113	332101025R1	CK725B1H-102K1,Chip ceramic
C114,C115	342101014R1	CC725CH1H-101J1,Chip ceramic
C116,C117	332121045R1	CK725B1C-104K1,Chip ceramic
C118,C119	342100802R1	CC725CH1H-080D1,Chip ceramic
C120	342100802R1	CC725CH1H-080D1,Chip ceramic
C122,C123	332161040R1	CK725F1E-104Z1,Chip ceramic
C124,C125	332161040R1	CK725F1E-104Z1,Chip ceramic
C128,C130	394621017 or 394721017	CE04W6.3V-100M(VR) or CE04W6.3V100M(SC),Elect.
C129	332161040R1	CK725F1E-104Z1,Chip ceramic
	Resistors	
R102,R103	435033314R1	RN72K1J-331JE,Chip carbon
R104,R105	435033314R1	RN72K1J-331JE,Chip carbon
R111,R112	435037504R1	RN72K1J-750JE,Chip carbon
R113,R114	435031004R1	RN72K1J-100JE,Chip carbon
R115,R116	435032244R1	RN72K1J-224JE,Chip carbon
R117,R118,R119	435031034R1	RN72K1J-103JE,Chip carbon
R122	435031044R1	RN72K1J-104JE,Chip carbon
R123,R124	435033314R1	RN72K1J-331JE,Chip carbon
R127,R128	435030004R1	RN72K1J-000JE,Chip carbon
	Terminal	
P112	25045758	NPJ-2PDO543
	Sockets	

P101	25052379	NSCT-9P2277
P120A	2009990917UL	NSAS-24P1446

Primary circuit PC board (NAPS-8382-2A)

CIRCUIT NO.	PART NO.	DESCRIPTION
	Transistor	
Q921	2215864 or 2213284 or 2213285 or 2212115	KTC3199-GR or 2SC1740S-R or 2SC1740S-S or 2SC2458-GR
	Diodes	
D921,D922 D923,D924 D925	22380260 or 22380035 223163 or 223205 or 223222	RL1N4003 or GP104003E 1SS133 or 1SS270A or WG713A
	Capacitors	
C901	3800039S or 3500196S	! ECQU2A103MLC or ! RE275V-103M,IS
C921	335622230	CK45F50V-223Z,Ceramic
C922	394654717	CE04W25V-470M(VR),Elect.
C923	335321025	CK45B50V-102K,Ceramic
	Resistors	
R921	453630824	RNU1WCJ-8.2,Metal
R922	417341034	R16J-10K,Carbon
R923	417341024	R16J-1K,Carbon
R926	417344724	R16J-4.7K,Carbon
	Power transformer	
T902	2301775	! NPT-1504D
	Fuse holders	
F901A,F901B F903A,F903B	25052133 25052133	! NSCT-1P2031 ! NSCT-1P2031
	Label	
F901C	29360842	
	AC outlet	
P902	25051126	! NSCT-4P913
	Socket	
P931B	25051230	NSCT-5P1020
	Relay	
RL901	25065670 or 25065671	! NRL-1P10A-DC9-180 or ! NRL-1P10A-DC9-181

Driver circuit PC board (NAAF-8383-2A)

CIRCUIT NO.	PART NO.	DESCRIPTION
	Transistors	
Q5000,Q5001	2210755 or	* 2SC1775A-E or
Q5002,Q5010	2210756 or	* 2SC1775A-F or
Q5011,Q5012	2211733	* 2SC1845-E
Q5003,Q5004	2215896 or	* KTC3200-BL or
Q5013,Q5014	2210755 or 2210756 or 2211733	* 2SC1775A-E or * 2SC1775A-F or * 2SC1845-E
Q5030,Q5031	2202094 or	2SA1360-Y or
Q5032	2202093	2SA1360-O
Q5033,Q5034	2215844 or 2215843 or 2211354 or 2211353	KTA1024-Y or KTA1024-O or 2SA949-Y or 2SA949-O
Q5040,Q5041	2202104 or	2SC3423-Y or
Q5042	2202103	2SC3423-O
Q5043,Q5044	2215854 or 2215853 or	KTC3206-Y or KTC3206-O or

	2211634 or 2211633	2SC2229-Y or 2SC2229-O
Q5050,Q5051	2215896 or	KTC3200-BL or
Q5052,Q5053	2215895 or	KTC3200-GR or
Q5054	2210755 or 2210756 or 2211733 or 2211732	2SC1775A-E or 2SC1775A-F or 2SC1845-E or 2SC1845-F
	Diodes	
D5000,D5001	224470562	MTZJ5.6B
D5002,D5003,D5004	224470562	MTZJ5.6B
CIRCUIT NO.	PART NO.	DESCRIPTION
	Capacitors	
C5000,C5001	374721015	ECQ-B50V-101K,Plastic
C5002,C5003	374721015	ECQ-B50V-101K,Plastic
C5004	374721015	ECQ-B50V-101K,Plastic
C5010,C5011	393384707	CE04W50V-47M(VX),Elect.
C5012,C5013	393381007	CE04W50V-10M(VX),Elect.
C5014	393381007	CE04W50V-10M(VX),Elect.
C5020,C5021	394681007	CE04W50V-10M(VX),Elect.
C5022,C5023	394681007	CE04W50V-10M(VX),Elect.
C5024	394681007	CE04W50V-10M(VX),Elect.
C5040,C5041	393342217	CE04W16V-220M(VX),Elect.
C5042,C5043	393342217	CE04W16V-220M(VX),Elect.
C5044	393342217	CE04W16V-220M(VX),Elect.
C5050,C5051	394684707	CE04W50V-47M(VR),Elect.
C5052,C5053	394684707	CE04W50V-47M(VR),Elect.
C5054	394684707	CE04W50V-47M(VR),Elect.
C5080,C5081	345020401	CC45SL50V-040C,Ceramic
C5082,C5083	345020401	CC45SL50V-040C,Ceramic
C5084	345020401	CC45SL50V-040C,Ceramic
C5090,C5091	374721015	ECQ-B50V-101K,Plastic film
C5092,C5093	374721015	ECQ-B50V-101K,Plastic film
C5094	374721015	ECQ-B50V-101K,Plastic film
C5100,C5101	394571007	CE04W63V-10M(VZ),Elect.
C5102	394571007	CE04W63V-10M(VZ),Elect.
C5103,C5104	394671007	CE04W63V-10M(VR),Elect.
C5110,C5111	394571007	CE04W63V-10M(VZ),Elect.
C5112	394571007	CE04W63V-10M(VZ),Elect.
C5113,C5114	394671007	CE04W63V-10M(VR),Elect.
	Resistors	
R5000,R5001	417341024	R16J-1K,Carbon
R5002,R5003	417341024	R16J-1K,Carbon
R5004	417341024	R16J-1K,Carbon
R5010,R5011	417345634	R16J-56K,Carbon
R5012,R5013	417345634	R16J-56K,Carbon
R5014	417345634	R16J-56K,Carbon
R5020,R5021	417343314	R16J-330,Carbon
R5022,R5023	417343314	R16J-330,Carbon
R5024	417343314	R16J-330,Carbon
R5030,R5031	417345634	R16J-56K,Carbon
R5032,R5033	417345634	R16J-56K,Carbon
R5034	417345634	R16J-56K,Carbon
R5040,R5041	417342224	R16J-2.2K,Carbon
R5042,R5043	417342224	R16J-2.2K,Carbon
R5044	417342224	R16J-2.2K,Carbon
R5050,R5051	417344724	R16J-4.7K,Carbon
R5052,R5053	417344724	R16J-4.7K,Carbon
R5054	417344724	R16J-4.7K,Carbon
R5060,R5061	417341224	R16J-1.2K,Carbon
R5062,R5063	417341224	R16J-1.2K,Carbon
R5064	417341224	R16J-1.2K,Carbon
R5080,R5081	417344714	R16J-470,Carbon

R5082,R5083	417344714	R16J-470,Carbon
R5084	417344714	R16J-470,Carbon
R5090,R5091	417341044	R16J-100K,Carbon
R5092,R5093	417341044	R16J-100K,Carbon
R5094	417341044	R16J-100K,Carbon
R5100,R5101	417341044	R16J-100K,Carbon
R5102,R5103	417341044	R16J-100K,Carbon
R5104	417341044	R16J-100K,Carbon
R5110,R5111	417341024	R16J-1K,Carbon
R5112,R5113	417341024	R16J-1K,Carbon
R5114	417341024	R16J-1K,Carbon
R5130,R5131	417342234	R16J-22K,Carbon
CIRCUIT NO.	PART NO.	DESCRIPTION
Resistors		
R5132,R5133	417341834	R16J-18K,Carbon
R5134	417341834	R16J-18K,Carbon
R5160,R5161	415471214	R25J-120,NF carbon
R5162,R5163	415471214	R25J-120,NF carbon
R5164	415471214	R25J-120,NF carbon
R5170,R5171	415471214	R25J-120,NF carbon
R5172,R5173	415471214	R25J-120,NF carbon
R5174	415471214	R25J-120,NF carbon
R5180,R5181	415471004	R25J-10,NF carbon
R5182,R5183	415471004	R25J-10,NF carbon
R5184	415471004	R25J-10,NF carbon
R5190,R5191	415471004	R25J-10,NF carbon
R5192,R5193	415471004	R25J-10,NF carbon
R5194,	415471004	R25J-10,NF carbon
R5200,R5201	417342234	R16J-22K,Carbon
R5220,R5221	417342734	R16J-27K,Carbon
R5222,R5223	417342734	R16J-27K,Carbon
R5224	417342734	R16J-27K,Carbon
Sockets		
P6000A,P6001A	25052288	NSCT-5P2185
P6002A,P6003A	25052288	NSCT-5P2185
P6004A	25052288	NSCT-5P2185
Plug		
P308A	25055155	NPLG-11P139
Retainer		
P6011B	27141859	(BUS-U)

AC inlet terminal PC board (NAETC-8388-2A)

CIRCUIT NO.	PART NO.	DESCRIPTION
	Terminal	
P901B	25055960	! NPLG-2P913

Secondary circuit PC board (NAPS-8389-2A)

CIRCUIT NO.	PART NO.	DESCRIPTION
	IC	
Q9001	222780565JRC or 222780574TOS	NJM78M56FA or TA78057S
	Transistor	
Q9002	2215975 or 2211455	KTA1266-GR or 2SA1015-GR
	Diodes	
D9001,D9002	22380260 or	RL1N4003 or
D9003,D9004	22380035	GP104003E
D9005	22380271 or 22380285 or 22380022	D3SBA20 or RS403M or RBV402
D9009,D9010	22380260 or	RL1N4003 or
D9011,D9013	22380035	GP104003E
D9012	224472704	MTZJ27D

Capacitors		
CIRCUIT NO.	PART NO.	DESCRIPTION
C9001,C9002	375523344	MMT50V-334J,Plastic
C9003	394661027S	CE04W35V-1000M(VR),Elect.
C9004	394664717	CE04W35V-470M(VR),Elect.
C9005	375523344	MMT50V-334J,Plastic
C9009	394662217	CE04W35V-220M(VR),Elect.
C9010	394644727S	CE04W16V-4700M(VR),Elect.
C9011	394651027S	CE04W25V-1000M(VR),Elect.
C9012	335622230	CK45F50V-223Z,Ceramic
C9013	394641007	CE04W16V-10M(VR),Elect.
C9014	394674717S	CE04W63V-470M(VR),Elect.
C9015,C9016	335622230	CK45F50V-223Z,Ceramic
C9017	374721024	ECQ-B50V-102J,Plastic

Resistors		
CIRCUIT NO.	PART NO.	DESCRIPTION
R9002	443522204	RS1/2WBJ-22,Metal oxide
R9003,R9004	417348224	R16J-8.2K,Carbon
R9005	417343334	R16J-33K,Carbon
R9006	453530474	RNU1/2WCJ-4.7,Metal
Sockets		
JL9501B	25051111	NSCT-7P898
JL9502A	25051111	NSCT-7P898
P6931A	25052532 or 25052348	NSCT-11P2429 or NSCT-11P2245
P6953B	25051528	NSCT-17P1315
P7502B	25052244	NSCT-11P2141
Screw		
D9002B	838430107	3TTB+10S(BC)
Radiator		
D9005A	27160211	RAD-68

Fuse terminal PC board (NAETC-8390-2A)

CIRCUIT NO.	PART NO.	DESCRIPTION
Capacitor		
C9591	374721044	ECQ-V50V-104J,Plastic
Resistors		
R9591,R9592	453530104	RNU1/2WCJ-1,Metal
R9594	453530224	RNU1/2WCJ-2.2,Metal
Fuse holders		
F9501A,F9501B	25052133	! NSCT-1P2031
Socket		
JL9501A	25051111	NSCT-7P898

Speaker terminal F/C PC board (NAETC-8400-1V)

CIRCUIT NO.	PART NO.	DESCRIPTION
Diodes		
D6600,D6602	223163 or 223205 or 223222	1SS133 or 1SS270A or WG713A
Capacitors		
C6600,C6602	374721034	ECQ-B50V-103J,Plastic film
Relays		
RL6600,RL6602	25065618	NRL-2P5A-DC24-158
Terminals		
P6600	25060389	NTM-4PDMN320
P6602	25060387	NTM-2PDMN318
Sockets		
P6804B	25051230	NSCT-5P1020
JL6805A	25051108	NSCT-4P895
Plugs		
P6800B,P6801B	25055722	NPLG-3P678

Thermal detector PC board (NAETC-8402-1V)

CIRCUIT NO.	PART NO.	DESCRIPTION
R6380	4000217	PTFL04BF471Q2N34B0 (80) ,Thermistor
R6381	4000220	PTFL04BC471Q2N34B0 (110) ,Thermistor
	Socket	
JL6402C	25051088	NSCT-4P875

Power amplifier PC board (NAAF-8397-1V)

CIRCUIT NO.	PART NO.	DESCRIPTION
	Transistors	
Q6010,Q6011	2213284 or	2SC1740S-R or
Q6012,Q6013	2213285	2SC1740S-S
Q6014	2213284 or	2SC1740S-R or
Q6020,Q6021	2213285	2SC1740S-S
	Transistors	
Q6022,Q6023	2213284 or	2SC1740S-R or
Q6024	2213285	2SC1740S-S
Q6030,Q6031	2203010	2SC5171
Q6032	2203010	2SC5171
Q6033,Q6034	2203010 or 2203434	2SC5171 or KTD2061-Y
Q6040,Q6041	2203000	2SA1930
Q6042	2203000	2SA1930
Q6043,Q6044	2203000 or 2203424	2SA1930 or KTB1369-Y
Q6070,Q6071	2215896 or	KTC3200-BL or
Q6072,Q6073	2210755 or	2SC1775A-E or
Q6074	2210756 or 2211733 or 2211732 or 2215895	2SC1775A-F or 2SC1845-E or 2SC1845-F or KTC3200-GR
Q6303,Q6304	2215995 or 2213354 or 2213355	KTA1267-GR or 2SA933S-R or 2SA933S-S
Q6601,Q6602	2215864 or	KTC3199-GR or
Q6604	2212115 or	2SC2458-GR or
Q6901	2213284 or 2213285	2SC1740S-R or 2SC1740S-S
Q6701,Q6702	2215896 or 2210755 or 2210756 or 2211732 or 2211733 or 2215895	KTC3200-BL or 2SC1775A-E or 2SC1775A-F or 2SC1845-F or 2SC1845-E or KTC3200-GR
Q6703	2215886 or 2211792 or 2211793 or 2215885	KTA1268-BL or 2SA992-F or 2SA992-E or KTA1268-GR
	Diodes	
D6000,D6001	223163 or	1SS133 or
D6002,D6003	223205 or	1SS270A or
D6004	223222	WG713A
D6010,D6011	223163 or	1SS133 or
D6012,D6013	223205 or	1SS270A or
D6014	223222	WG713A
D6306,D6307	223163 or	1SS133 or
D6701,D6702	223205 or	1SS270A or
D6906	223222	WG713A
D6703,D6704	224470512	MTZJ5.1B
D6705,D6706	22380260 or	RL1N4003 or
D6901,D6902	22380035	GP104003E
D6707	224470512	MTZJ5.1B

D6904,D6905	22380337	D10XB60H
	Capacitors	
C6040,C6041	394584707	CE04W50V-47M(VZ),Elect.
C6042,C6043	394584707	CE04W50V-47M(VZ),Elect.
C6044	394584707	CE04W50V-47M(VZ),Elect.
C6050,C6051	374721034	ECQ-B50V-103J,Plastic film
C6052,C6053	374721034	ECQ-B50V-103J,Plastic film
C6054	374721034	ECQ-B50V-103J,Plastic film
C6230,C6231	374724734	ECQ-V50V-473J,Plastic film
C6232,C6233	374724734	ECQ-V50V-473J,Plastic film
C6234	374724734	ECQ-V50V-473J,Plastic film
C6701,C6706	394621017	CE04W6.3V-100M(VR),Elect.
C6703,C6707	335622230	CK45F50V-223Z,Ceramic
C6704	394680107	CE04W50V-1M(VR),Elect.
C6708	374722224	ECQ-B50V-222J,Plastic film
CIRCUIT NO.	PART NO.	DESCRIPTION
	Capacitors	
C6901,C6902	3504408	CE69W63V-12000M,Elect.
C6903	374721044	ECQ-V50V-104J,Plastic film
C6904,C6905	374733344	ECQ-V100-334J,Plastic film
C6906,C6907	374721044	ECQ-V50V-104J,Plastic film
	Resistors	
R6000,R6001	417345624	R16J-5.6K,Carbon
R6002,R6003	417345624	R16J-5.6K,Carbon
R6004	417345624	R16J-5.6K,Carbon
R6010,R6011	417343924	R16J-3.9K,Carbon
R6012,R6013	417343924	R16J-3.9K,Carbon
R6014,R6054	417343924	R16J-3.9K,Carbon
R6030,R6031	417341024	R16J-1K,Carbon
R6032,R6033	417341024	R16J-1K,Carbon
R6034	417341024	R16J-1K,Carbon
R6040,R6041	5210258	N06HR1KBC,Trimming
R6042,R6043	5210258	N06HR1KBC,Trimming
R6044	5210258	N06HR1KBC,Trimming
R6050,R6051	417343924	R16J-3.9K,Carbon
R6052,R6053	417343924	R16J-3.9K,Carbon
R6060,R6061	415470224	R25J-2.2,NF carbon
R6062,R6063	415470224	R25J-2.2,NF carbon
R6064	415470224	R25J-2.2,NF carbon
R6070,R6071	415471214	R25J-120,NF carbon
R6072,R6073	415471214	R25J-120,NF carbon
R6074	415471214	R25J-120,NF carbon
R6080,R6081	415470224	R25J-2.2,NF carbon
R6082,R6083	415470224	R25J-2.2,NF carbon
R6084,R6090	415470224	R25J-2.2,NF carbon
R6091,R6092	415470224	R25J-2.2,NF carbon
R6093,R6094	415470224	R25J-2.2,NF carbon
R6100,R6101	4000201 or	RF-5EGKR22 or
R6102,R6103	4500245 or	BPR55FK0.22 or
R6104	4000132	RGC55 0.22,Metal plate
R6140,R6141	417342234	R16J-22K,Carbon
R6142,R6143	417342234	R16J-22K,Carbon
R6144	417342234	R16J-22K,Carbon
R6150,R6151	417341234	R16J-12K,Carbon
R6152,R6153	417341234	R16J-12K,Carbon
R6154	417341234	R16J-12K,Carbon
R6160,R6161	417343334	R16J-33K,Carbon
R6162,R6163	417343334	R16J-33K,Carbon
R6164	417343334	R16J-33K,Carbon
R6170,R6171	417344734	R16J-47K,Carbon
R6172,R6173	417344734	R16J-47K,Carbon
R6174,R6184	417344734	R16J-47K,Carbon
R6180,R6181	417344734	R16J-47K,Carbon

R6182,R6183	417344734	R16J-47K,Carbon
R6200,R6201	417341014	R16J-100,Carbon
R6202,R6203	417341014	R16J-100,Carbon
R6204	417341014	R16J-100,Carbon
R6230,R6231	453630824	RNU1WCJ-8.2,Metal
R6232,R6233	453630824	RNU1WCJ-8.2,Metal
R6234	453630824	RNU1WCJ-8.2,Metal
R6240,R6241	417342244	R16J-220K,Carbon
R6242,R6243	417342244	R16J-220K,Carbon
R6244	417342244	R16J-220K,Carbon
R6306	417341034	R16J-10K,Carbon
R6307,R6309	417344714	R16J-470,Carbon
R6308,R6310	417344724	R16J-4.7K,Carbon
R6605	443521004	RS1/2WBJ-10,Metal oxide
R6631,R6632	417341024	R16J-1K,Carbon
R6634,R6902	417341024	R16J-1K,Carbon
CIRCUIT NO.	PART NO.	DESCRIPTION
Resistors		
R6701,R6707	417342234	R16J-22K,Carbon
R6702	417341034	R16J-10K,Carbon
R6704	417344734	R16J-47K,Carbon
R6706	417342244	R16J-220K,Carbon
R6708	417343334	R16J-33K,Carbon
R6709	417345624	R16J-5.6K,Carbon
R6710	417341234	R16J-12K,Carbon
R6750,R6751	443523914	RS1/2WBJ-390,Metal oxide
R6901	443521004	RS1/2WBJ-10,Metal oxide
Relays		
RL6901,RL6902	25065584 or 25065516	NRL-1P10A-DC12-140 or NRL-1P10A-DC12-097
Fuse holders		
F6901A,F6901B	250113	SN5051
F6902A,F6902B	250113	SN5051
Label		
Sockets		
JL6402A	25051088	NSCT-4P875
JL6802A	25051108	NSCT-4P895
JL6803A,JL6952A	25051109	NSCT-5P896
P6800A,P6801A	25051255	NSCT-3P1045
P995	2009990875UL	NSAS-6P1334
Plugs		
P6000B,P6001B	25056010	NPLG-5P0960
P6002B,P6003B	25056010	NPLG-5P0960
P6004B	25056010	NPLG-5P0960
P6080,P6081	25055038	NPLG-2P29
P6082,P6083	25055038	NPLG-2P29
P6084	25055038	NPLG-2P29
P6301	25055042	NPLG-3P32
P6804A	25055701	NPLG-5P657
P6953A	25055806	NPLG-17P762
P931A	25055701	NPLG-5P657
Retainer		
P6011A	27141860	(BUS-D)
Heat sink		
D6904A	27160499	RAD-164
Screws		
D6904B,D6905B	82143010	3P+10FN(BC)

Secondary circuit PC board (NAETC-8398-1V)

CIRCUIT NO.	PART NO.	DESCRIPTION
JL6952B	25051109	NSCT-5P896,Socket

Speaker terminal PC board (NAETC-8399-1V)

CIRCUIT NO.	PART NO.	DESCRIPTION
D6803,D6805	Diodes 223163 or 223205 or 223222	1SS133 or 1SS270A or WG713A
C6803,C6805	Capacitors 374721034	ECQ-B50V-103J,Plastic film
RL6803,RL6805	Relays 25065618	NRL-2P5A-DC24-158
P6802 P6072A,P6073B	Terminals 25060393 25060301	NTM-8PDMN324 NTM-1P232(M1700)
JL6802B,JL6805B JL6803B	Sockets 25050281 25050282	NSCT-4P109 NSCT-5P110
P6850,P6851	Holders 27190926	KGPS-18RF
Display circuit PC board (NADIS-8406-1V)		
CIRCUIT NO.	PART NO.	DESCRIPTION
Q7502	ICs 22241680AR2	M66005-0001AFP
Q7501	FL tube 212249A	HNA-16SM10T
U7501	Remote sensor 241336	PIC-37043TH2
Q7503	Transistors 2216175R2 or 2213145R2	KTC3875-GR or 2SC2712-GR
Q7581,Q7583 Q7701	2216190R2 or 2214470R2	KRC102S or RN1402
D7501	Diodes 224550820R2 or 224660824R2	UDZS8.2B or HZU8.2B
D7502,D7504 D7508 D7581 D7583 D7701	223234R2 or 223269R2 225290T 225291DT 223234R2 or 223269R2	1SS352 or 1SS355 SEL4110R SEL4910D-D 1SS352 or 1SS355
L7501,L7502	Coils 233533M022R2 or 231237M022R2	NCH-1587-022M or NCH-1471
C7501,C7503 C7502 C7504,C7505 C7506 C7507 C7508,C7511 C7509 C7510,C7512 C7513,C7533 C7514,C7705 C7534 C7535,C7536	332161040R1 355783309 332154730R1 332154730R1 375524744 332161040R1 353721019 342101014R1 332161040R1 353721019 332154730R1 332161040R1	CK725F1E-104Z1,Chip ceramic CE04W50V-33M,Elect. CK725F1H-473Z1,Chip ceramic CK725F1H-473Z1,Chip ceramic MMT50V-474J,Plastic film CK725F1E-104Z1,Chip ceramic CE04W6.3V-100M(S),Elect. CC725CH1H-101J1,Chip ceramic CK725F1E-104Z1,Chip ceramic CE04W6.3V-100M(S),Elect. CK725F1H-473Z1,Chip ceramic CK725F1E-104Z1,Chip ceramic
R7501,R7502 R7503 R7504,R7505 R7506,R7507 R7581	Resistors 435032214R1 435032734R1 435033324R1 435031024R1 435032214R1	RN72K1J-221JE,Chip carbon RN72K1J-273JE,Chip carbon RN72K1J-332JE,Chip carbon RN72K1J-102JE,Chip carbon RN72K1J-221JE,Chip carbon

R7583	435031814R1	RN72K1J-181JE,Chip carbon
R7611,R7621	435033314R1	RN72K1J-331JE,Chip carbon
R7612,R7622	435034714R1	RN72K1J-471JE,Chip carbon
R7613,R7623	435035614R1	RN72K1J-561JE,Chip carbon
R7614,R7624	435038214R1	RN72K1J-821JE,Chip carbon
R7615,R7625	435031224R1	RN72K1J-122JE,Chip carbon
R7616,R7626	435032224R1	RN72K1J-222JE,Chip carbon
R7617,R7627	435033924R1	RN72K1J-392JE,Chip carbon
R7618,R7628	435031234R1	RN72K1J-123JE,Chip carbon
R7631,R7641	435033314R1	RN72K1J-331JE,Chip carbon
R7632,R7642	435034714R1	RN72K1J-471JE,Chip carbon
R7633,R7643	435035614R1	RN72K1J-561JE,Chip carbon
R7634,R7644	435038214R1	RN72K1J-821JE,Chip carbon
R7635,R7645	435031224R1	RN72K1J-122JE,Chip carbon
R7636,R7646	435032224R1	RN72K1J-222JE,Chip carbon
R7637,R7647	435033924R1	RN72K1J-392JE,Chip carbon
R7638	435031234R1	RN72K1J-123JE,Chip carbon

CIRCUIT NO.**PART NO.****DESCRIPTION**

	Relay	
RL7701	25065610 or 25065645 or 25065654 or 25065658	NRL-2P1A-DC4.5-156 or NPL-2P1A-DC4.5-169 or NRL-2P2A-DC4.5-172 or NRL-2P2A-DC4.5-173
	Switches	
S7611,S7612	25035714 or	NPS-111-S677 or
S7613,S7614	25035718	NPS-111-S681
S7615,S7618	25035714 or	NPS-111-S677 or
S7621,S7622	25035718	NPS-111-S681
S7623,S7624	25035714 or	NPS-111-S677 or
S7627,S7628	25035718	NPS-111-S681
S7629,S7631	25035714 or	NPS-111-S677 or
S7632,S7633	25035718	NPS-111-S681
S7634,S7635	25035714 or	NPS-111-S677 or
S7636,S7637	25035718	NPS-111-S681
S7638,S7639	25035714 or	NPS-111-S677 or
S7641,S7642	25035718	NPS-111-S681
S7643,S7644	25035714 or	NPS-111-S677 or
S7645,S7646	25035718	NPS-111-S681
S7647,S7648	25035714 or	NPS-111-S677 or
S7656,S7657	25035718	NPS-111-S681
	Sockets	
JL7501A	25051089	NSCT-5P876
JL7701A	25051089	NSCT-5P876
P7501A	25052360 or 25052544	NSCT-23P2257 or NSCT-23P2441
P7502A	25052244 or 25052057 or 25051855	NSCT-11P2141 or NSCT-11P1844 or NSCT-11P1642
	Holder	
Q7501A	27191222A	(FL)

Video terminal PC board (NAVD-8407-1V)

CIRCUIT NO.	PART NO.	DESCRIPTION
	ICs	
Q2001,Q2002	22241946R2	NJM2595M
Q2003	22241946R2	NJM2595M
Q2004	22241779	LC74763-9836
Q2011	22241221R2	TC9164AF
Q2021	22241849R2	MM1512

CIRCUIT NO.	PART NO.	DESCRIPTION
Transistors		
Q2005	2216175R2 or	KTC3875-GR or
Q2201,Q2202	2213145R2	2SC2712-GR
Q2006,Q2007	2215510R2	RN1443
Q2008,Q2009	2216185R2 or	KTA1504-GR or
Q2022	2214375R2	2SA1162-GR
Q2010	2214530R2 or	RN2402 or
	2216220R2	KRA102S
Q2012,Q2013	2215510R2	RN1443
Q2014,Q2015	2215510R2	RN1443
Q2017,Q2018	2215510R2	RN1443
Q2020	2215510R2	RN1443
Diodes		
D2001,D2002	223234R2 or	1SS352 or
D2003	223269R2	1SS355
D2201,D2202	223234R2 or	1SS352 or
	223269R2	1SS355
Oscillator		
X2001	3010318	HC-49/U0314.318M
Coils		
L2001	231292J056R2	NCH-1572
L2002,L2003	231237K022R2 or	NCH-1471 or
L2005	233533K022R2	NCH-1587-022K
Capacitors		
C2001,C2002	332101025R1	CK725B1H-102K1,Chip ceramic
C2003	332101025R1	CK725B1H-102K1,Chip ceramic
C2004,C2005	394641007 or	CE04W16V-10M(VR) or
C2007,C2008	394741007	CE04W16V10M(SC),Elect.
C2006,C2009	332161040R1	CK725F1E-104Z1,Chip ceramic
C2010,C2011	342104704R1	CC725CH1H-470J1,Chip ceramic
C2012,C2018	342104704R1	CC725CH1H-470J1,Chip ceramic
C2013,C2014	394641007 or	CE04W16V-10M(VR) or
C2019,C2020	394741007	CE04W16V10M(SC),Elect.
C2015	332161040R1	CK725F1E-104Z1,Chip ceramic
C2016,C2017	342104704R1	CC725CH1H-470J1,Chip ceramic
C2021,C2022	332161040R1	CK725F1E-104Z1,Chip ceramic
C2023,C2024	394621017 or	CE04W6.3V-100M(VR) or
C2027,C2028	394721017	CE04W6.3V100M(SC),Elect.
C2025,C2026	332161040R1	CK725F1E-104Z1,Chip ceramic
C2029,C2030	332161040R1	CK725F1E-104Z1,Chip ceramic
C2031,C2032	394621017 or	CE04W6.3V-100M(VR) or
C2053	394721017	CE04W6.3V100M(SC),Elect.
C2033	332161040R1	CK725F1E-104Z1,Chip ceramic
C2041	342101002R1	CC725CH1H-100D1,Chip ceramic
C2042	342101804R1	CC725CH1H-180J1,Chip ceramic
C2045,C2046	342104704R1	CC725CH1H-470J1,Chip ceramic
C2047,C2048	342104704R1	CC725CH1H-470J1,Chip ceramic
C2049,C2057	394680107 or	CE04W50V-1M(VR) or
	394780107	CE04W50V1.0M(SC),Elect.
C2050	342104704R1	CC725CH1H-470J1,Chip ceramic
C2051	394624717 or	CE04W6.3V-470M(VR) or
	394724717	CE04W6.3V470M(SC),Elect.
C2052	332161040R1	CK725F1E-104Z1,Chip ceramic
C2054	394683397	CE04W50V-0.33M(VR),Elect.
C2055	332101225R1	CK725B1H-122K1,Chip ceramic
C2056	374726824	ECQ-B50V-682J,Plastic film
C2058	374722234	ECQ-B50V-223J,Plastic film
C2059	342102204R1	CC725CH1H-220J1,Chip ceramic
C2060	342102704R1	CC725CH1H-270J1,Chip ceramic

C2061	394684797 or 394784797	CE04W50V-0.47M(VR) or CE04W50V0.47M(SC),Elect.
C2063	375524744	MMT50V-474J,Plastic film
C2064	394641007 or 394741007	CE04W16V-10M(VR) or CE04W16V10M(SC),Elect.
C2065	394621017 or 394721017	CE04W6.3V-100M(VR) or CE04W6.3V100M(SC),Elect.
C2066,C2067	332161040R1	CK725F1E-104Z1,Chip ceramic
C2068	332161040R1	CK725F1E-104Z1,Chip ceramic
C2071,C2072	332161040R1	CK725F1E-104Z1,Chip ceramic
C2073,C2078	394624717 or 394724717	CE04W6.3V-470M(VR) or CE04W6.3V470M(SC),Elect.
C2074,C2076	342111024R1	CC725CH1E-102J1,Chip ceramic
C2080	394642207 or 394742207	CE04W16V-22M(VR) or CE04W16V22M(SC),Elect.
C2081,C2082	394621017 or	CE04W6.3V-100M(VR) or
C2083,C2084	332161040R1	CK725F1E-104Z1,Chip ceramic
C2201,C2202	332101025R1	CK725B1H-102K1,Chip ceramic
C6887	342111024R1	CC725CH1E-102J1,Chip ceramic
C6891	332101025R1	CK725B1H-102K1,Chip ceramic
CIRCUIT NO.	PART NO.	DESCRIPTION
	Resistors	
R2001,R2002	435031034R1	RN72K1J-103JE,Chip carbon
R2003	435031034R1	RN72K1J-103JE,Chip carbon
R2004,R2005	435037504R1	RN72K1J-750JE,Chip carbon
R2006,R2007	435037504R1	RN72K1J-750JE,Chip carbon
R2008,R2009	435037504R1	RN72K1J-750JE,Chip carbon
R2010,R2011	435037504R1	RN72K1J-750JE,Chip carbon
R2012,R2013	435037504R1	RN72K1J-750JE,Chip carbon
R2014,R2015	435037504R1	RN72K1J-750JE,Chip carbon
R2016,R2017	435037504R1	RN72K1J-750JE,Chip carbon
R2018,R2019	435037504R1	RN72K1J-750JE,Chip carbon
R2020,R2021	435037504R1	RN72K1J-750JE,Chip carbon
R2031,R2032	435030004R1	RN72K1J-000JE,Chip carbon
R2033,R2034	435030004R1	RN72K1J-000JE,Chip carbon
R2041,R2042	435032224R1	RN72K1J-222JE,Chip carbon
R2043,R2044	435032224R1	RN72K1J-222JE,Chip carbon
R2045,R2065	435031034R1	RN72K1J-103JE,Chip carbon
R2046,R2055	435031024R1	RN72K1J-102JE,Chip carbon
R2047,R2057	435034734R1	RN72K1J-473JE,Chip carbon
R2048,R2053	435036824R1	RN72K1J-682JE,Chip carbon
R2049,R2062	435033324R1	RN72K1J-332JE,Chip carbon
R2050	435032214R1	RN72K1J-221JE,Chip carbon
R2051	435038244R1	RN72K1J-824JE,Chip carbon
R2052	435031524R1	RN72K1J-152JE,Chip carbon
R2054	435031214R1	RN72K1J-121JE,Chip carbon
R2056,R2061	435032724R1	RN72K1J-272JE,Chip carbon
R2058,R2059	435032214R1	RN72K1J-221JE,Chip carbon
R2060	435031234R1	RN72K1J-123JE,Chip carbon
R2063	435036804R1	RN72K1J-680JE,Chip carbon
R2064	435032224R1	RN72K1J-222JE,Chip carbon
R2066,R2067	435032214R1	RN72K1J-221JE,Chip carbon
R2069,R2090	435030004R1	RN72K1J-000JE,Chip carbon
R2070	435032204R1	RN72K1J-220JE,Chip carbon
R2071,R2072	435031044R1	RN72K1J-104JE,Chip carbon
R2073,R2074	435031044R1	RN72K1J-104JE,Chip carbon
R2075,R2076	435031044R1	RN72K1J-104JE,Chip carbon
R2077,R2078	435031044R1	RN72K1J-104JE,Chip carbon
R2079,R2080	435031044R1	RN72K1J-104JE,Chip carbon

R2081,R2082	435031044R1	RN72K1J-104JE,Chip carbon
R2083,R2084	435031044R1	RN72K1J-104JE,Chip carbon
R2085,R2086	435031044R1	RN72K1J-104JE,Chip carbon
R2087	435033314R1	RN72K1J-331JE,Chip carbon
R2088	435038204R1	RN72K1J-820JE,Chip carbon
R2089	435030394R1	RN72K1J-039JE,Chip carbon
R2091,R2096	435031024R1	RN72K1J-102JE,Chip carbon
R2092,R2097	435034714R1	RN72K1J-471JE,Chip carbon
R2093,R2098	435038204R1	RN72K1J-820JE,Chip carbon
R2094,R2095	435031214R1	RN72K1J-121JE,Chip carbon
R2099	435030274R1	RN72K1J-027JE,Chip carbon
R2101,R2102	435031024R1	RN72K1J-102JE,Chip carbon
R2103,R2104	435031024R1	RN72K1J-102JE,Chip carbon
R2105,R2106	435031024R1	RN72K1J-102JE,Chip carbon
R2107,R2108	435031024R1	RN72K1J-102JE,Chip carbon
R2201,R2202	435034754R1	RN72K1J-475JE,Chip carbon
R2203	435034754R1	RN72K1J-475JE,Chip carbon
R2204,R2205	435031024R1	RN72K1J-102JE,Chip carbon
R6916	435031014R1	RN72K1J-101JE,Chip carbon
R6926	435032234R1	RN72K1J-223JE,Chip carbon

CIRCUIT NO.	PART NO.	DESCRIPTION
	Relays	
RL2201,RL2202	25065645 or	NPL-2P1A-DC4.5-169 or
RL2203,RL2204	25065654 or	NRL-2P2A-DC4.5-172 or
RL2205	25065658	NRL-2P2A-DC4.5-173
	Terminals	
P2001,P2002	25045730	NPJ-10PDBY518
P2003	25045728	NPJ-15PDBY516
P2201	25045814	NPJ-12PDGLR594
P6803	25045738	NPJ-1PDP526
	Sockets	
P2004	25051239	NSCT-14P1029
P2005	25051234	NSCT-9P1024
JL6802A,JL6802B	25051088	NSCT-4P875

Volume PC board (NASW-8411-1V)

CIRCUIT NO.	PART NO.	DESCRIPTION
	Capacitors	
C7515,C7516	332161040R1	CK725F1E-104Z1,Chip ceramic
	Rotary encoder	
S7502	25065611	EC16B24C25
	Sockets	
JL7501B	25051089	NSCT-5P876

Headphone terminal PC board (NAETC-8412-1V)

CIRCUIT NO.	PART NO.	DESCRIPTION
	Coils	
L7701,L7703	233533M022R2 or	NCH-1587-022M or
L7704	231237M022R2	NCH-1471
	Capacitors	
C7701,C7702	342111024R1	CC725CH1E-102J1,Chip ceramic
C7703	374722215	ECQ-B50V-221K,Plastic film
C7704	342101014R1	CC725CH1H-101J1,Chip ceramic
	Terminal	
P7705	25045385	YKB26-5153
	Plug	
JL7701B	25055626	NPLG-5P588

Integra Division of

ONKYO CORPORATION

Sales & Product Planning Div. : 2-1, Nisshin-cho, Neyagawa-shi, OSAKA 572-8540, JAPAN

Tel: 072-831-8023 Fax: 072-831-8124 <http://www.onkyo.com/jp/>

Integra Division of

ONKYO U.S.A. CORPORATION

18 Park Way, Upper Saddle River, N.J. 07458, U.S.A.

Tel: 201-785-2600 Fax: 201-785-2650 <http://www.integrahometheater.com>