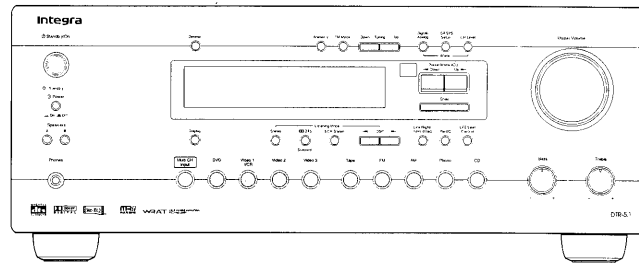

Integra. SERVICE MANUAL**AUDIO VIDEO
CONTROL RECEIVER
MODEL DTR-5.1****Black model**

BMDD

120V AC, 60Hz

SAFETY-RELATED COMPONENT WARNING!!

COMPONENTS IDENTIFIED BY MARK \triangle ON THE SCHEMATIC DIAGRAM AND IN THE PARTS LIST ARE CRITICAL FOR RISK OF FIRE AND ELECTRIC SHOCK. REPLACE THESE COMPONENTS WITH ONKYO PARTS WHOSE PARTS NUMBERS APPEAR AS SHOWN IN THIS MANUAL.

MAKE LEAKAGE-CURRENT OR RESISTANCE MEASUREMENTS TO DETERMINE THAT EXPOSED PARTS ARE ACCEPTABLY INSULATED FROM THE SUPPLY CIRCUIT BEFORE RETURNING THE APPLIANCE TO THE CUSTOMER.

TABLE OF CONTENTS

Specifications.....	2
Service procedures.....	3
Panel views.....	4
IC block diagrams and descriptions.....	7
Microprocessor connection diagram.....	14
Microprocessor terminal descriptions.....	15
FL tube view.....	16
Printed circuit board-part list.....	17
Adjustment procedures and confirmation.....	23
Wiring view.....	25
Block diagram.....	27
DSP schematic diagram	29
DSP PC board view	31
Video circuit PC board view.....	32
Video circuit schematic diagram.....	33
Power amplifier PC board view.....	35
Power amplifier schematic diagram.....	37
Preamplifier PC board view.....	40
Preamplifier schematic diagram.....	41
Display PC board view.....	43
Display circuit schematic diagram.....	45
Main circuit PC board view.....	47
Main circuit schematic diagram	49
Exploded view.....	51
Parts list.....	53
Packing view.....	54

ONKYO®
AUDIO COMPONENTS

SPECIFICATIONS

AMPLIFIER SECTION

Continuous Average Power output (FTC) All channels:	70 watts per channel min. RMS at 8 ohms, 2 channels driven from 20 Hz to 20 kHz with no more than 0.08% total harmonic distortion. 90 watts min. RMS at 6 ohms, 2 channels driven from 1 kHz with no more than 0.1% total harmonic distortion.
Maximum Power output (EIAJ)	130 watts at 6 ohms
Total Harmonic Distortion:	0.08% at rated power (Front)
IM Distortion:	0.08% at rated power (Front)
Damping Factor:	60 at 8 ohms (Front)
Input Sensitivity and Impedance	
PHONO:	2.5 mV, 50 kohms
LINE (CD, TAPE, DVD, VIDEO 1, 2, 3):	300 mV, 50 kohms
MULTICHANNEL INPUT FRONT L/R, SURROUND L/R, CENTER:	300 mV, 50 kohms
SUBWOOFER:	53 mV, 50 kohms
COAXIAL 1, 2 (DIGITAL):	0.5 Vp-p, 75 ohms
Output Level and Impedance	
Rec out (TAPE, VIDEO 1):	300 mV, 2.2 kohms
Pre out (SUBWOOFER):	1 V, 2.2 kohms
Phono Overload:	70 mV RMS at 1 kHz, 0.5% T.H.D.
Frequency Response:	5 Hz to 100 kHz, +1/-3 dB
RIAA Deviation:	20 Hz to 20 kHz, ± 0.8 dB
Tone Control	
Bass:	± 10 dB at 100 Hz
Treble:	± 10 dB at 10 kHz
Signal-to-Noise Ratio	
Phono:	80 dB (IHF A, 5 mV input)
CD/Tape:	100 dB (IHF A)

VIDEO SECTION

Input sensitivity/Impedance (DVD, VIDEO 1, 2, 3)	
VIDEO (Composite):	1 Vp-p, 75 ohms
S-VIDEO (Y signal):	1 Vp-p/75 ohms
Output Level/Impedance (VIDEO 1, MONITOR)	
VIDEO (Composite):	1 Vp-p, 75 ohms
S-VIDEO (Y signal):	1 Vp-p, 75 ohms

TUNER SECTION

FM

Tuning Range:	87.5 — 108.0 MHz
Usable Sensitivity	
Mono:	11.2 dBf, 1.0 μ V (75 ohms)
Stereo:	17.2 dBf, 2.0 μ V (75 ohms)
50 dB Quieting Sensitivity	
Mono:	17.2 dBf, 2.0 μ V (75 ohms)
Stereo:	37.2 dBf, 20 μ V (75 ohms)
Capture Ratio:	2.0 dB
Image Rejection Ratio:	40 dB

IF Rejection Ratio:	90 dB
Signal-to-Noise Ratio	
Mono:	76 dB
Stereo:	70 dB
Alternate Channel Attenuation:	55 dB
Selectivity:	50 dB (DIN)
AM Suppression Ratio:	50 dB
Total Harmonic Distortion	
Mono:	0.2%
Stereo:	0.3%
Frequency Response:	30 Hz — 15 kHz, ± 1.0 dB
Stereo Separation:	45 dB at 1 kHz 30 dB at 100 Hz — 10 kHz

AM

Tuning Range:	530—1,710 kHz (10 kHz steps)
Usable Sensitivity:	30 μ V
Image Rejection Ratio:	40 dB
IF Rejection Ratio:	40 dB
Signal-to-Noise Ratio:	40 dB
Total Harmonic Distortion:	0.7%

GENERAL

Power Supply:	AC 120 V, 60 Hz
Power Consumption:	3.9 A
Dimensions (W x H x D):	17-1/8" x 6-7/8" x 15-5/8"
Weight:	27.3 lbs.

REMOTE CONTROL

Transmitter:	Infrared
Signal range:	Approx. 5 meters, 16 ft.
Power supply:	Two "AA" batteries (1.5 V x 2)

Specifications and features are subject to change without notice.

SERVICE PROCEDURES

1. Replacing the fuses

 This symbol located near the fuses indicates that the fuse used is fast operating type. For continued protection against fire hazard, replace with same type fuse. For fuse rating refer to the marking adjacent to the symbol.

 Ce symbole indique que le fusible utilise est a rapide. Pour une protection permanente, n'utiliser que fusibles de meme type. Ce dernier est la qu le present symbol est appse.

CIRCUIT NO.	PART NO.	DESCRIPTION
F911	252198Y	8A-UL, Primary

2. To initialize the unit

This device employs a microprocessor to perform various functions and operations. If interference generated by an external power supply, radio wave, or other electrical source results in accident which causes the specified operations and functions to operate abnormally.

To perform a result, please follow the procedure below.

1. Press and hold down the VIDEO-1 button, then press the SPEAKER A button.
2. After "clear" is displayed, the preset memory and each mode stored in the memory, such as surround, are initialized and will return to the factory setting.

3. Safety-check out

(Only U.S.A. model)

After correcting the original service problem, perform the following safety check before releasing the set to the customer. Connect the insulating-resistance tester between the plug of power supply cord and screw on the back panel.
Specifications: 3.3Mohm \pm 10% at 500V.

4. Memory Preservation

This unit does not require memory preservation batteries. A built-in memory power back-up system preserves the contents of the memory during power failures and even when the unit is unplugged. The unit must be plugged in order to charge the back-up system.

The memory preservation period after the unit has been unplugged varies depending on climate and placement of the unit. On the average, memory contents are protected over a period of a few weeks after the last time the unit has been unplugged. This period is shorter when the unit is exposed to a highly humid climate.

5. Changing the AM band step

With the exception of the worldwide models, a tuning step selector switch is not provided. When you change the band step, change the parts as shown below.

	To 10kHz	To 9kHz
R7077	Open	2.2k
R7130	10k	18k

MICROPROCESSOR CONNECTION DIAGRAM

S7138	S7137	S7136	S7135	S7134	S7133	S7132	S7131	K3
S7128	S7127	S7126	S7125	S7124	S7123	S7122	S7121	K2
S7118	S7117	S7116	S7115	S7114	S7113	S7112	S7111	K1
S7109	S7108	S7107	S7106	S7104	S7103	S7102	S7101	K0

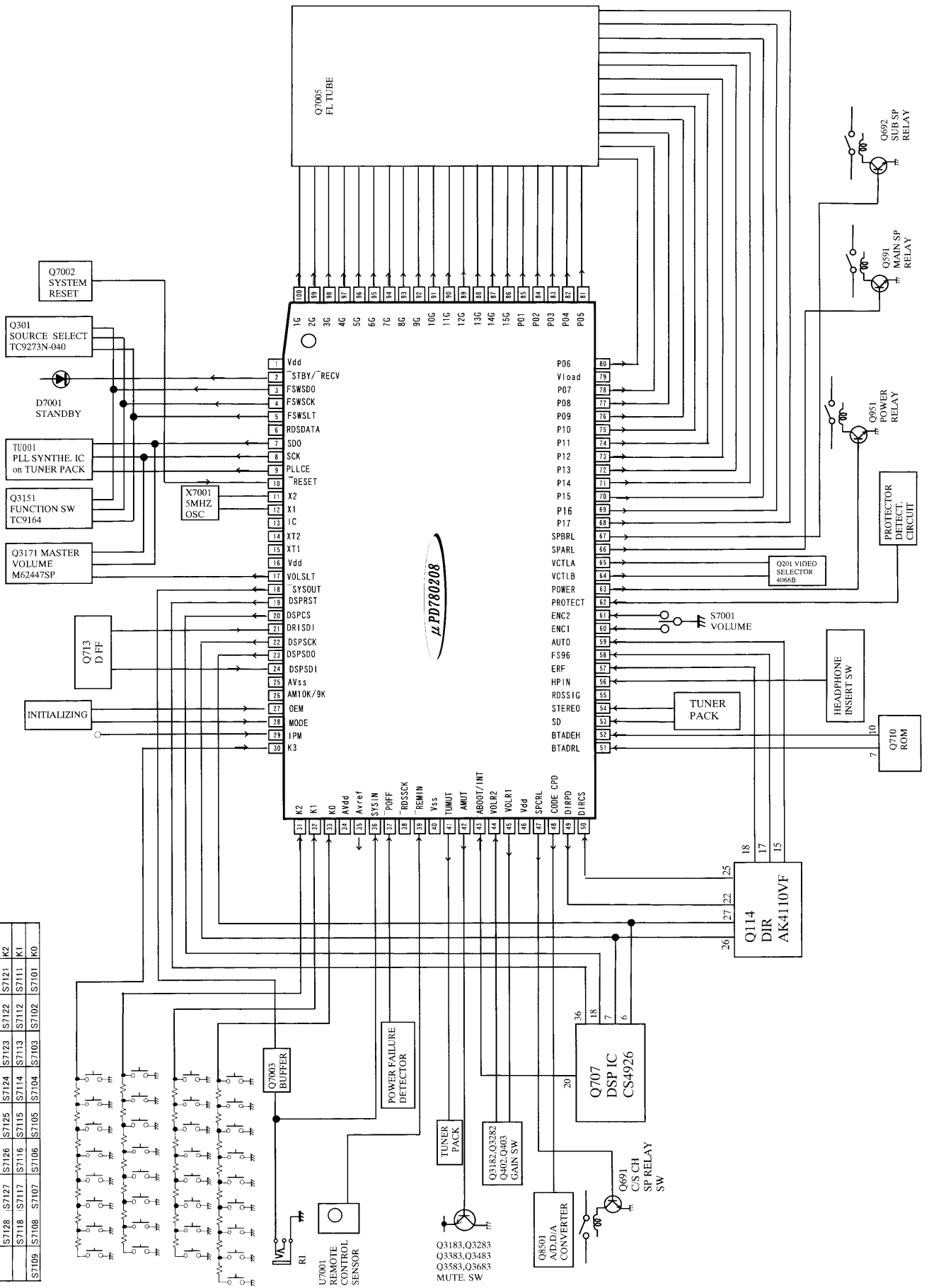

MICROPROCESSOR TERMINAL DESCRIPTION

No.	Symbol	I/O	Description	No.	Symbol	I/O	Description
1	V _{DD}	-	Power supply pin	38	RDSSCK	I	Clock input pin from RDS decoder
2	STBY/RECV	0	Standby/Received indicator control output pin	39	REMIN	I	Signal input pin for remoter controller
3	FSWSDO	0	Serial data output pin to function switch IC	40	AV _{SS}	-	Ground pin
4	FSWSCK	0	Serial clock output pin to function switch IC	41	TUMUT	0	Muting control signal output pin for tuner section
5	FSWSLT	0	Serial latch output pin to function switch IC	42	AMUT	0	Muting control signal output pin for amplifier section
6	RDSDATA	1	Data input pin from RDS decoder	43	ABOOTS/INT	I/O	AUTOBOOT/INTREQ input/output pin
7	SDO	0	Serial data output pin to PLL and Electro volume ICs.	44	VOL RL2	0	Control output pin for volume selector relay 2
8	SCK	0	Serial clock output pin to PLL and Electro volume ICs	45	VOL RL1	0	Control output pin for volume selector relay 1
9	PLLCE	0	Serial data latch output pin to PLL IC	46	V _{DD}	-	Power supply pin
10	RESET	1	System reset input pin	47	SPCRL	0	Speaker relay control output pin
11	X2	0	Master clock connection pins.	48	CODE CPD	0	Power down control output pin for CODEC IC
12	X1	1	Connect the ceramic oscillator across the both pins.	49	DIRPD	0	Power down control output pin for AK4110
13	IC	1	Internal connection pin.	50	DIRCS	0	Chip select output pin for AK4110
14	XT2	0	Sub clock connection pins. Not used.	51	BTADRH	0	Setting input pin for LSB address of boot ROM
15	XT1	1	Not used.	52	BTADRL	0	Setting input pin for MSB address of boot ROM
16	V _{DD1}	-	Power supply pin	53	SD	1	Broadcast detection input
17	VOLSLT	0	Serial latch output pin to Electro volume IC	54	STEREO	1	FM stereo broadcast detection input pin
18	SYSOUT	0	Signal output pin for system code	55	RDSSIG	1	Signal input pin from RDS decoder
19	DSPRST	0	Reset signal output pin to DSP IC CS492604	56	HPIN	1	Detection input pin when the headphones are inserted.
20	DSPCS	0	Chip select output pin to DSP IC	57	ERF	1	Not used.
21	DRISOI	1	Serial data input pin from the digital audio interface receiver IC AK4110	58	FS96	1	Not used.
22	DSPSCK	0	Serial clock output pin to AK4110 and CS492604	59	AUTO	1	AUTO signal input pin from AK4110
23	DSPSDO	0	Serial data output pin to AK4110 and CS492604	60	ENC1	1	Rotary encoder input pin for volume control
24	DSPSDI	1	Serial data input pin from CS4926	61	ENC2	1	Rotary encoder input pin for volume control
25	AV _{SS}	1	Ground pin for A/D converter	62	PROTECT	1	Detection input pin for protection circuit
26	AM9K/10K	1	Initializing input pin for AM band step. 9 kHz step at "H".	63	POWER	0	Control output pin for power switch relay
27	OEM	1	Initializing input pin for unit setting	64	VCTRB	0	Control output pin for video selector switch
28	MODE	1	Initializing input pin for operation mode	65	VCTRA	0	Control output pin for video selector switch
29	IPM	1	IPM switch connection pin. Not used.	66	SPARL	0	Control output pin for speaker relay A
30-33	K3-K0	1	Operation key connection pins.	67	SPBRL	0	Control output pin for speaker relay B
34	AV _{DD}	-	Power supply pin for A/D converter	68-78	P17-P07	0	Segment output pins
35	AVREF	1	Reference voltage input pin for A/D converter	79	VLOAD	-	Power supply pin for FL controller
36	SYSIN	1	System code input pin	80-85	P06-P01	0	Segment output pins
37	POFF	1	Power failure detect input pin	86-100	15G-1G	0	Grid output pins

FL TUBE VIEW

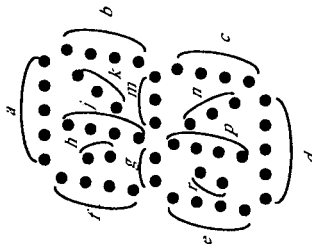
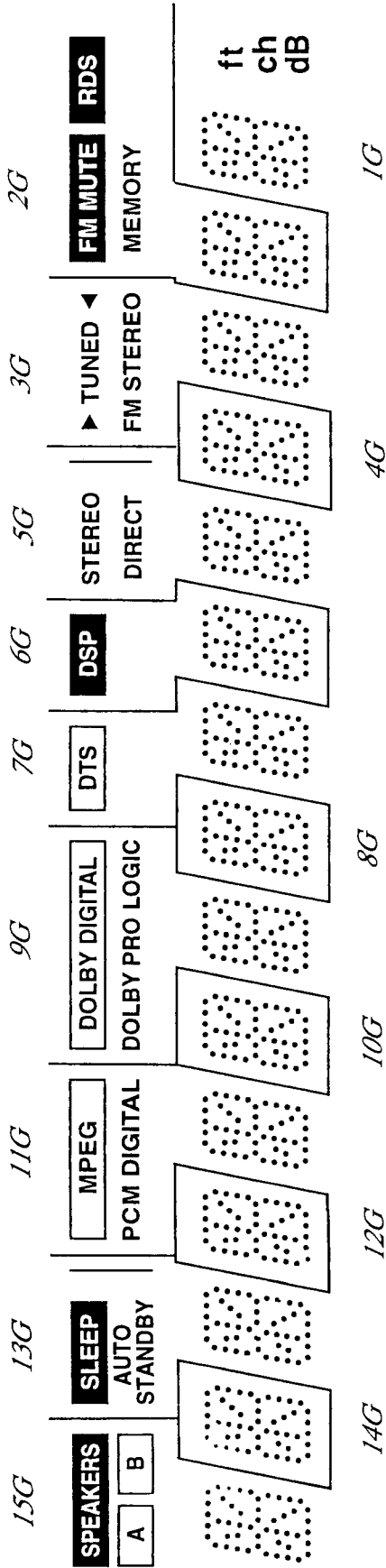

	15G	14G	13G	12G	11G	10G	9G	8G	7G	6G	5G	4G	3G	2G	1G
P1	SPEAKERS		SLEEP		MPEG		DOLBY DIGITAL		DTS	DSP	STEREO		TUNED	RDS	dB
P2	A		AUTO STANDBY										▶	FM MUTE	ch
P3	B				PCM DIGITAL		DOLBY PRO LOGIC						◀	MEMORY	ft
P4	c	c	c	c	c	c	c	c	c	c	c	c	c	c	c
P5	h	h	h	h	h	h	h	h	h	h	h	h	h	h	h
P6	j	j	j	j	j	j	j	j	j	j	j	j	j	j	j
P7	k	k	k	k	k	k	k	k	k	k	k	k	k	k	k
P8	b	b	b	b	b	b	b	b	b	b	b	b	b	b	b
P9	f	f	f	f	f	f	f	f	f	f	f	f	f	f	f
P10	m	m	m	m	m	m	m	m	m	m	m	m	m	m	m
P11	g	g	g	g	g	g	g	g	g	g	g	g	g	g	g
P12	c	c	c	c	c	c	c	c	c	c	c	c	c	c	c
P13	e	e	e	e	e	e	e	e	e	e	e	e	e	e	e
P14	r	r	r	r	r	r	r	r	r	r	r	r	r	r	r
P15	p	p	p	p	p	p	p	p	p	p	p	p	p	p	p
P16	n	n	n	n	n	n	n	n	n	n	n	n	n	n	n
P17	d	d	d	d	d	d	d	d	d	d	d	d	d	d	d

PRINTED CIRCUIT BOARD PARTS LIST

NOTE: THE COMPONENTS IDENTIFIED BY MARK Δ ARE
CRITICAL FOR RISK OF FIRE AND ELECTRIC SHOCK.
REPLACE ONLY WITH PART NUMBER SPECIFIED.

PRE., AMPLIFIER PC BOARD (NAVD-6746-1F)

CIRCUIT NO.	PART NO.	DESCRIPTION
	ICs	
Q203	22240373	BA7625
Q3171	22241296	M62447SP
Q3180,Q3181	22270247 or	BA15218N or
Q3281,Q3381	22240293	NJM4558L-D
Q3184	22240025	LC4966
Q3581	22270247 or 22240293	BA15218N or NJM4558L-D
	Transistors	
Q201,Q204	2213354, 2212125 or 2215995	2SA933S-R, 2SA1048-GR or KTA1267-GR
Q202	2212286 or 2212285	2SC2878-B or 2SC2878-A
Q205	2213640, 2214660 or 2215830	DTC123JS, RN1205 or KRC105M
Q3182,Q3183	2213631 or 2213632	RN1241-A or RN1241-B
Q3185	2213510, 2214350 or 2215770	DTA114ES, RN2202 or KRA102M
Q3186	2213290, 2214230 or 2215960	DTC114ES, RN1202 or KRC102M
Q3187	2213580, 2215780 or 2212600	RN2203, KRA103M or DTA124ES
Q3188	2213560, 2215820 or 221282	RN1204, KRC104M or DTC144ES
Q3282,Q3283	2213631 or	RN1241-A or
Q3383,Q3483	2213632	RN1241-B
Q3583	2213631 or	RN1241-A or
Q3683,Q3684	2213632	RN1241-B
	Diodes	
D201,D202	223163 or	1SS133 or
D207,D208	223205	1SS270A
D3171	224470512	MTZJ5.1B
D3182	223163 or 223205	1SS133 or 1SS270A
D3276,D3277	224470472	MTZJ4.7B
	Capacitors	
C201-C204	354780229	2.2 μ F,50V,Elect.
C205,C206	354724719	470 μ F,6.3V,Elect.
C210	354721019	100 μ F,6.3V,Elect.
C3171,C3177	354741009	10 μ F,16V,Elect.
C3173,C3175	354744709	47 μ F,16V,Elect.
C3186,C3271	354741009	10 μ F,16V,Elect.
C3187,C3287	374721534	0.015 μ F \pm 5%,50V,Plastic
C3189,C3195	354784709	47 μ F,50V,Elect.
C3192,C3193	354744709	47 μ F,16V,Elect.
C3194	354780479	4.7 μ F,50V,Elect.
C3196,C3296	354782209	22 μ F,50V,Elect.
C3286	354741009	10 μ F,16V,Elect.
C3289,C3295	354784709	47 μ F,50V,Elect.
C3371,C3471	354741009	10 μ F,16V,Elect.

CIRCUIT NO.	PART NO.	DESCRIPTION
	Capacitors	
C3381,C3481	354782209	22 μ F,50V,Elect.
C3384,C3484	354744709	47 μ F,16V,Elect.
C3571,C3671	354741009	10 μ F,16V,Elect.
C3581,C3681	354782209	22 μ F,50V,Elect.
C3586,C3684	354744709	47 μ F,16V,Elect.
C3683	374724734	0.047 μ F \pm 5%,50V,Plastic
	Terminals	
P201	25045477	NPJ-1PDBL295
P202,P203	25045363	NPJ-3PDYE208
	Sockets	
P204	25051430	NSCT-8P1217
P205	25051438	NSCT-16P1225
P206	25051426	NSCT-4P1213
P391	2009990554UL	NSAS-16P0734
P601	2009990541UL	NSAS-10P0712

S TERMINAL PC BOARD (NAVD-6747-1F)

This PC board is included to NAVD-6746.

CIRCUIT NO.	PART NO.	DESCRIPTION
	ICs	
Q2003,Q2004	22240373	BA7625
	Transistors	
Q2001,Q2002	2212125,	2SA1048-GR,
Q2005,Q2006	2215995 or 2213354	KTA1267-GR or 2SA933S-R
	Diodes	
D2001,D2002	223163 or 223205	1SS133 or 1SS270A
	Capacitors	
C2001-C2009	354780229	2.2 μ F,50V,Elect.
C2010,C2012	354724719	470 μ F,6.3V,Elect.
C2011	354780229	2.2 μ F,50V,Elect.
C2024	354781009	10 μ F,50V,Elect.
C2028,C2029	354722219	220 μ F,6.3V,Elect.
	Terminals	
P2001,P2002	25051957	NSCT-12P1744

PRIMARY CIRCUIT PC BOARD (NAPS-6748-1F)

CIRCUIT NO.	PART NO.	DESCRIPTION
	Transistor	
Q951	2213640, 2214660 or 2215830	DTC123JS, RN1205 or KRC105M
	Diodes	
D952	22380032, 22380035 or 22380260	1SR139-100, GP104003E or RL1N4003
D955	223163 or 223205	1SS133 or 1SS270A
	Power transformer	
T902	2301381 or 2301258	Δ NPT-1358D or Δ NPT-1294D
	Capacitors	
C901	3500196S	Δ RE275V-103M
C952	354743319	330 μ F,16V,Elect.
	Resistor	
R901	431533355	Δ RC1/2GFKUL-3.3M

NOTE: THE COMPONENTS IDENTIFIED BY MARK Δ ARE CRITICAL FOR RISK OF FIRE AND ELECTRIC SHOCK. REPLACE ONLY WITH PART NUMBER SPECIFIED.

CIRCUIT NO.	PART NO.	DESCRIPTION
	Relay	
RL901	25065561, Δ	NRL-1P5A-DC12-127,
	25065508, Δ	NRL-1P10A-DC12-093,
	25065515 or Δ	NRL-1P5A-DC12-096 or
	25065526 Δ	NRL-1P5A-DC12-102
	Fuse	
F911	252198Y Δ	8A-UL
	Fuse holders	
F901,F902	25052133 Δ	NSCT-1P2031
	AC outlet	
P903	25051126 Δ	NSCT-4P913
	Socket	
JL961B	25050267	NSCT-3P95
	Plug	
P901A	25055675 Δ	NPLG-2P631

DIGITAL INPUT PC BOARD (NADG-6749-1F)

CIRCUIT NO.	PART NO.	DESCRIPTION
	IC	
Q7301	222755	TC74HCU04P
	Photo couplers	
U7301,U7302	24120037	TORX178B
Q7304	24120043	ON3131
	Coils	
L7301	233454K220	NCH-1452 220K
L7302,L7303	233454M022	NCH-1452 022M
	Capacitors	
C7302	354721019	100 μ F,6.3V,Elect.
C7307,C7311	374721044	0.1 μ F \pm 5%,50V,Plastic
	Terminals	
P7301,P7304	25045504	NPJ-1PDBL319
P7302,P7303	25045478	NPJ-1PDOR296
	Plugs	
P7205C	25055238	NPLG-7P222
P7206C	25055235	NPLG-4P219

POWER SWITCH PC BOARD (NAPS-6750-1F)

CIRCUIT NO.	PART NO.	DESCRIPTION
S901	25035550 Δ	NPS-111-L512P,Switch
C902	3500196S Δ	RE275V-103M,IS capacitor

SPEAKER TERMINAL B PC BOARD (NAETC-6751-1C)

CIRCUIT NO.	PART NO.	DESCRIPTION
	Transistors	
Q691,Q692	2213640,	DTC123JS,
	2214660 or	RN1205 or
	2215830	KRC105M
	Diodes	
D691,D692	223163 or	1SS133 or
	223205	1SS270A
	Terminal	
P603	25060296	NTM-8PDMN227
	Relays	
RL601,RL602	25065563,	NRL-2P5A-DC24-129,
	25065510 or	NRL-2P5A-DC24-095 or
	25065590	NRL-2P8A-DC24-144
	Socket	
JL602B	25051112	NSCT-8P899

INPUT SWITCH PC BOARD (NAETC-6752-1F)

CIRCUIT NO.	PART NO.	DESCRIPTION
	ICs	
Q301	22240864	TC9273N-004
Q302	22270247 or	BA15218N
	22240293	NJM4558L-D
	Capacitors	
C315,C316	354741009	10 μ F,16V,Elect.
C321,C322	354782209	22 μ F,50V,Elect.
	Terminals	
P301,P302	25045491 or	NPJ-4PDBL308 or
	25045582	NPJ-4PDRW393
P305	25045565 or	NPJ-6PDBL380 or
	25045583	NPJ-6PDRW394
	Sockets	
P303	25051440	NSCT-18P1227
P304	25051426	NSCT-4P1213

AC INLET PC BOARD (NAETC-6754-1C)

CIRCUIT NO.	PART NO.	DESCRIPTION
P901D	25055960 Δ	NPLG-2P913,AC inlet
P901E	2009990547UL	NSAS-2P0724,Socket

MULTI-CHANNEL INPUT PC BOARD (NAETC-6757-1F)

CIRCUIT NO.	PART NO.	DESCRIPTION
	ICs	
Q241-Q243	22270247 or	BA15218N
	22240293	NJM4558L-D
	Capacitors	
C248,C249	354741009	10 μ F,16V,Elect.
	Terminal	
P241	25045585 or	NPJ-6PDBRW396 or
	25045584	NPJ-6PDBRW395
	Plug	
P242A	25055995	NPLG-9P947

POWER AMPLIFIER PC BOARD (NAAF-6760-1C)

CIRCUIT NO.	PART NO.	DESCRIPTION
	Transistors	
Q1501,Q1502	2211732,	* 2SC1845-F,
Q601-Q604	2210755,	* 2SC1775A-E,
	2210756 or	* 2SC1775A-F or
	2211733	* 2SC1845-E
Q1504,Q1505	2211353,	2SA949-O,
Q1507	2215843 or	KTA1024-O or
	2215844	KTA1024-Y
Q1508	2211633,	2SC2229-O,
	2215853 or	KTC3206-O or
	2215854	KTC3206-Y
Q1509	2212653 or	2SC3421-O or
	2212654	2SC3421-Y
Q1510	2203010 or	2SC5171 or
	2203434	KTD2061-Y
Q1511	2203000 or	2SA1930 or
	2203424	KTB1369-Y
Q1512	2203063,	* 2SC5198-O,
Q623,Q624	2202523,	* 2SC4468-O,
	2202524,	* 2SC4468-Y,
	2202526 or	* 2SC4468-P or
	2203062	* 2SC5198-R

CIRCUIT NO.	PART NO.	DESCRIPTION	CIRCUIT NO.	PART NO.	DESCRIPTION
	Transistors			Capacitors	
Q1513	2203053,	* 2SA1941-O,	C627,C628	354772219	220 μ F,63V,Elect.
Q625,Q626	2202513,	* 2SA1695-O,	C631-C634	354774709	47 μ F,63V,Elect.
	2202514,	* 2SA1695-Y,	C635-C638	354771009	10 μ F,63V,Elect.
	2202516 or	* 2SA1695-P or	C639,C640	354780109	1 μ F,50V,Elect.
	2203052	* 2SA1941-R	C681	354781009	10 μ F,50V,Elect.
Q1515	2212115,	2SC2458-GR,		Resistors	
	2215864 or	KTC3199-GR or	R1512,R1513	443528204	82 Ω \pm 5%,1/2W,Metal oxide
	2213284	2SC1740S-R	R1515	443526804	68 Ω \pm 5%,1/2W,Metal oxide
Q1591	2213640,	DTC123JS,	R1516	443528204	82 Ω \pm 5%,1/2W,Metal oxide
	2214660 or	RN1205 or	R1517	443525604	56 Ω \pm 5%,1/2W,Metal oxide
	2215830	KRC105M	R1519	443522214	220 Ω \pm 5%,1/2W,Metal oxide
Q605,Q606	2211353,	2SA949-O,	R1522,R1523	453530224	2.2 Ω \pm 5%,1/2W,Metal
Q613,Q614	2215843 or	KTA1024-O or	R1524	4000132,	RGC55 0.22,
	2215844	KTA1024-Y		4000201 or	RF-5EGKR22 or
Q1503	2211732,	2SC1845-F,		4500245	BPR55FK0.22,Metal plate
Q1514	2210755,	2SC1775A-E,	R1529	453630824	8.2 Ω \pm 5%,1W,Metal
Q609,Q610	2210756 or	2SC1775A-F or	R1532	5210288	N06HR2.2KBE,Trimming
Q627,Q628	2211733	2SC1845-E	R1534,R1535	4500159	0.22 Ω \pm 5%,1/4W,Metal
Q611,Q612	2215864,	KTC3199-GR,	R623-R626	443528204	82 Ω \pm 5%,1/2W,Metal oxide
	2212115 or	2SC2458-GR or	R629,R630	443525604	56 Ω \pm 5%,1/2W,Metal oxide
	2213284	2SC1740S-R	R633,R634	443526804	68 Ω \pm 5%,1/2W,Metal oxide
Q615,Q616	2212653 or	2SC3421-O or	R635,R636	443528204	82 Ω \pm 5%,1/2W,Metal oxide
	2212654	2SC3421-Y	R641,R642	443522214	220 Ω \pm 5%,1/2W,Metal oxide
Q617,Q618	2211633,	2SC2229-O	R643-R646	453530224	2.2 Ω \pm 5%,1/2W,Metal
	2215853 or	KTC3206-O	R647,R648	4000132,	RGC55 0.22,
	2215854	KTC3206-Y		4000201 or	RF-5EGKR22 or
Q619,Q620	2203010 or	2SC5171 or		4500245	BPR55FK0.22,Metal plate
	2203434	KTD2061-Y	R655,R656	453630824	8.2 Ω \pm 5%,1W,Metal
Q621,Q622	2203000 or	2SA1930 or	R659,R660	4500268	2.2 Ω \pm 5%,1/2W,Metal
	2203424	KTB1369-Y	R673,R674	5210288	N06HR2.2KBE,Trimming
Q629,Q630	2215843,	KTA1024-O,	R675-R678	4500159F	0.22 Ω \pm 5%,1/4W,Metal
	2211353 or	2SA949-O or		Relay	
	2215844	KTA1024-Y	RL1501	25065574	NRL-1P5A-DC24-134
	Diodes			Sockets	
D1501,D1506	223163 or	1SS133 or	JL501B	25050283	NSCT-6P111
D607,D608	223205	1SS270A	JL602A	25051112	NSCT-8P899
	Coils		JL902B	25050282	NSCT-5P110
L1501	231176SY	S-1.3C	JL903B	25050281	NSCT-4P109
L601,L602	231176SY	S-1.3C		Plugs	
	Capacitors		P1511	25055038	NPLG-2P29
C1501	354784709	47 μ F,50V,Elect.	P601A	25055236	NPLG-5P220
C1502	374721015	100pF \pm 10%,50V,Plastic	P611,P612	25055038	NPLG-2P29
C1503	354742219	220 μ F,16V,Elect.			
C1504,C1505	354781009	10 μ F,50V,Elect.			
C1510	374724734	0.047 μ F \pm 5%,50V,Plastic			
C1511	374721044	0.1 μ F \pm 5%,50V,Plastic			
C1512	354744709	47 μ F,16V,Elect.			
C1530	354780109	1 μ F,50V,Elect.			
C1533,C1534	354771009	10 μ F,63V,Elect.			
C601,C602	354784709	47 μ F,50V,Elect.			
C603,C604	374721015	100pF \pm 10%,50V,Plastic			
C605,C606	354744709	47 μ F,16V,Elect.			
C607,C608	354742219	220 μ F,16V,Elect.			
C615,C616	354781009	10 μ F,50V,Elect.			
C619,C620	354781009	10 μ F,50V,Elect.			
C621,C622	374724734	0.047 μ F \pm 5%,50V,Plastic			
C623,C624	374721044	0.1 μ F \pm 5%,50V,Plastic			
				FRONT CHANNEL POWER AMPLIFIER PC BOARD (NAAF-6761-1C)	
			CIRCUIT NO.	PART NO.	DESCRIPTION
				Transistors	
			Q501-Q504	2211732,	* 2SC1845-F,
				2210755,	* 2SC1775A-E,
				2210756 or	* 2SC1775A-F or
				2211733	* 2SC1845-E
			Q505,Q506	2210755,	2SC1775A-E,
			Q527,Q528	2210756,	2SC1775A-F,
				2211733 or	2SC1845-E or
				2211732	2SC1845-F
			Q507-Q510	2211353,	2SA949-O,
				2215843 or	KTA1024-O or
				2215844	KTA1024-Y

CAUTION: Replacement of the transistor of mark * , if necessary, must be made from the same beta group (HFE) as the original type.

CIRCUIT NO.	PART NO.	DESCRIPTION	CIRCUIT NO.	PART NO.	DESCRIPTION
	Transistors			Resistors	
Q513,Q514	2211353, 2215844 or 2215843	2SA949-O, KTA1024-Y or KTA1024-O	R521-R524	443528204	82 Ω \pm 5%, 1/2W, Metal oxide
Q515,Q516	2211633, 2215854 or 2215853	2SC2229-O, KTC3206-Y or KTC3206-O	R525,R526	443526804	68 Ω \pm 5%, 1/2W, Metal oxide
Q517,Q518	2212654 or 2212653	2SC3421-Y or 2SC3421-O	R527,R528	443528204	82 Ω \pm 5%, 1/2W, Metal oxide
Q519,Q520	2203010 or 2203434	2SC5171 or KTD2061-Y	R529,R530	443525604	56 Ω \pm 5%, 1/2W, Metal oxide
Q521,Q522	2203000 or 2203424	2SA1930 or KTB1369-Y	R539-R542	453530224	2.2 Ω \pm 5%, 1/2W, Metal
Q523,Q524	2203063, 2202523, 2202524, 2202526 or 2203062	* 2SC5198-O, * 2SC4468-O, * 2SC4468-Y, * 2SC4468-P or * 2SC5198-R	R543,R544	443522214	220 Ω \pm 5%, 1/2W, Metal oxide
Q525,Q526	2203053, 2202513, 2202514, 2202516 or 2203052	* 2SA1941-O, * 2SA1695-O, * 2SA1695-Y, * 2SA1695-P or * 2SA1941-R	R547,R548	4000132, 4000201 or 4500245	RGC55 0.22, RF-5EGKR22 or BPR55FK0.22, Metal plate
Q529,Q530	2212115, 2213284 or 2215864	2SC2458-GR, 2SC1740S-R or KTC3199-GR	R555,R556	453630824	8.2 Ω \pm 5%, 1W, Metal
Q581,Q582	2210755, 2210756, 2211733 or 2211732	2SC1775A-E, 2SC1775A-F, 2SC1845-E or 2SC1845-F	R557,R558	443623914	390 Ω \pm 5%, 1W, Metal oxide
Q583	2211793 or 2211792	2SA992-E or 2SA992-F	R573,R574	5210259	N06HR2KBC, Trimming
Q591	2213640, 2214660 or 2215830	DTC123JS, RN1205 or KRC105M	R591,R592	4500171	2.2 Ω \pm 5%, 1/4W, Metal
D511,D512	223163 or 223205	1SS133 or 1SS270A		Sockets	
D571	224470512	MTZJ5.1B	JL501A	25051110	NSCT-6P897
L501,L502	231176SY	S-1.3C	JL503A	25051112	NSCT-8P899
C501,C502	393884707	47 μ F, 50V, Elect.	JL901A	25051111	NSCT-7P898
C503,C504	374721015	100pF \pm 10%, 50V, Plastic	JL902A	25051109	NSCT-5P896
C505,C506	354742219	220 μ F, 16V, Elect.	JL903A	25051108	NSCT-4P895
C507-C510	354781009	10 μ F, 50V, Elect.	P502	200B010420UL	NSAS-4P0717
C517,C518	374724734	0.047 μ F \pm 5%, 50V, Plastic	P504	2002381460UL	NSAS-14P0710
C519,C520	374721044	0.1 μ F \pm 5%, 50V, Plastic		Plugs	
C521,C522	354744709	47 μ F, 16V, Elect.	P511,P512	25055038	NPLG-2P29
C525,C526	354771019	100 μ F, 63V, Elect.	P520A	25055913	NPLG-7P866
C581	354721019	100 μ F, 6.3V, Elect.		Retainer	
C583	354780109	1 μ F, 50V, Elect.	C916A	27141757	Bus
C905,C906	374731044	0.1 μ F \pm 5%, 100V, Plastic		SPEAKER TERMINAL PC BOARD (NAETC-6763-1C)	
C915,C916	3504356	10000 μ F, 56V, Elect.		CIRCUIT NO.	PART NO.
				Diodes	DESCRIPTION
			D591	223163 or 223205	1SS133 or 1SS270A
			RL501	25065563, 25065510 or 25065590	NRL-2P5A-DC24-129, NRL-2P5A-DC24-095 or NRL-2P8A-DC24-144
			P501	25060297	NTM-6PDMN228
			JL503B	25051112	NSCT-8P899
				Relay	
				Terminal	
				Socket	
				SECONDARY CIRCUIT PC BOARD (NAETC-6766-1C)	
				CIRCUIT NO.	PART NO.
				Capacitors	DESCRIPTION
			C992	374731044	0.1 μ F \pm 5%, 100V, Plastic
			C993,C994	374721044	0.1 μ F \pm 5%, 50V, Plastic
			R991,R992	453530104	1 Ω \pm 5%, 1/2W, Metal
			R993	4500229	0.1 Ω \pm 5%, 1/4W, Metal
			JL901B	25051111	NSCT-7P898
			JL911B	25050284	NSCT-7P112
				Sockets	
				VOLUME CONTROL PC BOARD (NAETC-6767-1C)	
				CIRCUIT NO.	PART NO.
				DESCRIPTION	
			JL701A	25051087	NSCT-3P874, Socket
			S7001	25065575	EC16B2425, Rotary encoder

DSP CIRCUIT PC BOARD (NADG-6575-6C)

CIRCUIT NO.	PART NO.	DESCRIPTION
		ICs
Q101,Q102	22240581R1 or 22241383R2	NJM4565M or NJM4565M-D
Q114	22241338R2	AK4110VF
Q701	22278033ENEC	MPC29M33HF
Q702	22241399R2	TC7WU04F
Q707	22241340R9	CS492604-CL
Q708,Q709	22274574ER2TO	TC74VHC574FT
Q710	22241415R2 or 22241532R3	LC372100PT-K34-TLM or IN-0095
Q713	22274244ER2TO	TC74VHC244FT
Q8501	22241341R3	AK4526A-VQ
		Diodes
D101,D102	223233R1 or	1SS355 or
D104-D109	223234R2	1SS352
		Coils
L108-L110	231237M022R2	NCH-1471
L170,L171	230921R2	BLM21B222SPT
L703-L705	231237M022R2	NCH-1471
L8501,L8502	231237M022R2	NCH-1471
R8507,R8508	230921R2	BLM21B222SPT
		Oscillators
X103	3010327 or 3010320	AT-4912.288MHz or AT-49 12.288MHz
X701	3010278	CST12.2MTW040
		Capacitors
C101,C102	356741009R2	10 μ F,16V,Elect.
C108	356741009R2	10 μ F,16V,Elect.
C115,C116	373021524R2	1500pF \pm 5%,50V,Plastic
C148,C158	356724709R2	47 μ F,6.3V,Elect.
C701,C702	354724719S	470 μ F,6.3V,Elect.
C703,C704	356721019R2	100 μ F,6.3V,Elect.
C716,C718	356724709R2	47 μ F,6.3V,Elect.
C8501,C8507	356721019R2	100 μ F,6.3V,Elect.
C8504	356741009R2	10 μ F,16V,Elect.
C8509-C8514	356741009R2	10 μ F,16V,Elect.
C8515-C8520	373023324R2	3300pF \pm 5%,50V,Plastic
C8521-C8526	373021524R2	1500pF \pm 5%,50V,Plastic
C8527-C8532	373021024R2	1000pF \pm 5%,50V,Plastic
		Sockets
P7004B	25052049, 25050980, 25051306, 25051847 or 25052236	NSCT-40P1836, NSCT-40P767, NSCT-40P1095, NSCT-40P1634 or NSCT-40P2133
P7205	2009990589UL	NSAS-14P0802

DISPLAY CIRCUIT PC BOARD (NADIS-6576-3F)

CIRCUIT NO.	PART NO.	DESCRIPTION
		FL tube
Q7005	212198	15-BT-64GNK
		Remote sensor
U7001	241330	PIC-26043TE2
		ICs
Q401	22240581R1 or 22241383R2	NJM4565M or NJM4565M-D
Q7001	22241479	MPD780208GF-064-3BA
Q761	22241383R2	NJM4565M-D

CIRCUIT NO.	PART NO.	DESCRIPTION
		Transistors
Q402,Q403	2215410R2	RN1441
Q7002	2214490R2	RN1404
Q7003,Q7004	2214540R2	RN2403
Q7202,Q7203	2214490R2	RN1404
Q763,Q764	2212445 or 2212446	2SK365-GR or 2SK365-BL
		Diodes
D7001	225290	SEL4110R
D7002,D7003	223233R1 or	1SS355 or
D7005-D7008	223234R2	1SS352
D7004	224490560R2	UDZ5.6B
D7009	224490750R2	UDZ7.5B
D7010	223233R1 or	1SS355 or
D7201	223234R2	1SS352
D761,D762	223233R1 or 223233R1	1SS355 or 1SS355
		Coils
L7001-L7003	231237K220R2	NCH-1477
		Oscillators
X7001	3010242	CST5.00MGW
		Capacitors
C401,C402	355744709	47 μ F,16V,Elect.
C407,C408	355741009	10 μ F,16V,Elect.
C7001	355780229	2.2 μ F,50V,Elect.
C7002	3000078	DX-5R5L104,Super
C7004,C7005	355721019	100 μ F,6.3V,Elect.
C7008,C7018	355721019	100 μ F,6.3V,Elect.
C7009,C7010	355780109	1 μ F,50V,Elect.
C7014	355780109	1 μ F,50V,Elect.
C7015	355741009	10 μ F,16V,Elect.
C7019,C7213	355721019	100 μ F,6.3V,Elect.
C761	355744709	47 μ F,16V,Elect.
C762	374723344	0.33 μ F \pm 5%,50V,Plastic
C763	374721544	0.15 μ F \pm 5%,50V,Plastic
C764	374721044	0.1 μ F \pm 5%,50V,Plastic
C767,C768	355744709	47 μ F,16V,Elect.
C769,C770	355741009	10 μ F,16V,Elect.
		Switches
S7101-S7109	25035652	NPS-111-S604
S7111-S7118	25035652	NPS-111-S604
S7121-S7128	25035652	NPS-111-S604
S7131-S7138	25035652	NPS-111-S604
		Sockets
JL702A	25051090	NSCT-6P877
P7001A	25052086,	NSCT-40P1873
P7004B	25050946, 25051344, 25051884 or 25052273	NSCT-40P733 NSCT-40P1133 NSCT-40P1671 NSCT-40P2170
P7206	2009990591UL	NSAS-8P0804
		Plug
JL701B	25055624	NPLG-3P586
		Holder
Q7005A	27191074	(FL)

MAIN PC BOARD (NAAR-6577-3F)

CIRCUIT NO.	PART NO.	DESCRIPTION
		ICs
Q251	222780053	78L05
Q261	22241383R2	NJM4565M-D
Q3151	22241221R2	TC9164AF
Q921	222780125	78M12HF
Q922	222790125	79M12HF
Q931	222780565JRC	NJM78M56FA
Q933,Q934	222780055	78M05HF
		Transistors
Q244	2214350,	RN2202,
	2215770 or	KRA102M or
	2213510	DTA114ES
Q245,Q246	2215024	2SD1468S-R
Q932	2215975 or	KTA1266-GR or
	2211455	2SA1015-GR
		Diodes
D203,D204	224490620R2	UDZ6.2B
D901	22380022 or	RBV402 or
	22380285F	RS403M
D931	224490620R2	UDZ6.2B
D932	223233R1 or	1SS355 or
	223234R2	1SS352
D933-D938	22380032,	1SR139-100,
D940,D941	22380035 or	GP104003E or
	22380260	RL1N4003
D939	224492700R2	UDZ27B
D942,D943	224490750R2	UDZ7.5B
		Capacitors
C266	354780229	2.2 μ F,50V,Elect.
C267,C268	354741009	10 μ F,16V,Elect.
C269,C270	354721019	100 μ F,6.3V,Elect.
C273,C274	374728224	8200pF \pm 5%,50V,Plastic
C275,C276	374721824	1800pF \pm 5%,50V,Plastic
C277,C278	354744709	47 μ F,16V,Elect.
C281	354741009	10 μ F,16V,Elect.
C282,C284	354780339	3.3 μ F,50V,Elect.
C3151,C3152	354741009	10 μ F,16V,Elect.
C923	3504213	4700 μ F,35V,Elect.
C924	354761029	1000 μ F,35V,Elect.
C927,C928	354741009	10 μ F,16V,Elect.
C930	355780229	2.2 μ F,50V,Elect.
C933	354742229	2200 μ F,16V,Elect.
C935	354741009	10 μ F,16V,Elect.
C936	354762219	220 μ F,35V,Elect.
C937	354772219	220 μ F,63V,Elect.
C942,C943	354741009	10 μ F,16V,Elect.
C944,C945	354744709	47 μ F,16V,Elect.
		Resistors
R921-R925	453532294	0.22 Ω \pm 5%,1/2W,Metal
R926,R927	452630564	5.6 Ω \pm 5%,1W,Metal
R929	441623304	33 Ω \pm 5%,1W,Metal oxide
R932	452530224	2.2 Ω \pm 5%,1/2W,Metal
R933	452630224	2.2 Ω \pm 5%,1W,Metal
R934	442522204	22 Ω \pm 5%,1/2W,Metal oxide
R937	452630334	3.3 Ω \pm 5%,1W,Metal
R938,R939	443523314	330 Ω \pm 5%,1/2W,Metal oxide

CIRCUIT NO.	PART NO.	DESCRIPTION
		Terminal
P261	25045491 or	NPJ-4PDBL308 or
	25045582	NPJ-4PDRW393
		Sockets
JL911A	25051111	NSCT-7P898
P101	25052024,	NSCT-15P1811,
	25050955,	NSCT-15P742,
	25051281,	NSCT-15P1070,
	25051822 or	NSCT-15P1609 or
	25052211	NSCT-15P2108
P242	200A2281810UL	NSAS-18P0731
P520	25052138	NSCT-7P2036
P7001B	25052049,	NSCT-40P1836,
	25050980,	NSCT-40P767,
	25051306,	NSCT-40P1095,
	25051847 or	NSCT-40P1634 or
	25052236	NSCT-40P2133
JL961A	25051107	NSCT-3P894
		Plugs
P204A	25055787	NPLG-8P743
P205A	25055795	NPLG-16P751
P206A,P304A	25055783	NPLG-4P739
P303A	25055797	NPLG-18P753
		Heat sinks
Q921	27160179	
Q922	27160229	RAD-078
Q933A	27160391	
		Screws
Q921B,Q922B	82143010	3P+10FN(BC),Pan head
Q933B,Q934B	82143010	3P+10FN(BC),Pan head

HEADPHONE TERMINAL PC BOARD (NAETC-6779-3F)

CIRCUIT NO.	PART NO.	DESCRIPTION
		Terminal
P7003	25045385	YKB26-5153
		Socket
JL702B	25051090	NSCT-6P877
		Plugs
P504B	25055445	NPLG-7P427

TONE CONTROL PC BOARD (NAETC-6780-3F)

CIRCUIT NO.	PART NO.	DESCRIPTION
		Plug
P391A	25055139	NPLG-9P123
		Capacitors
C391,C392	374721534	0.015 μ F \pm 5%,50V,Plastic
		Resistor
R391,R392	5104356Y	N14RLC100KWT20Z,Variable

ADJUSTMENT PROCEDURES AND CONFIRMATION

1. Idling current adjustment

Before Idling adjustment, turn the trimming resistors R573, R574, R673, R674 and R1532 to counter clockwise. Connect the DC voltmeter to sockets P511, P512, P611, P612 and P1511.

After turn POWER to ON, adjust the trimming resistors R573, R574, R673, R674 and R1532 so that the reading of voltmeter becomes $2.5 \pm 0.2\text{mV}$.

After adjustment, attach the top cover.

Confirm the voltage of above points after five minutes.

Readjust the above resistors so that the voltage becomes $6.5 \pm 0.2\text{mV}$.

Note: No load and No signal

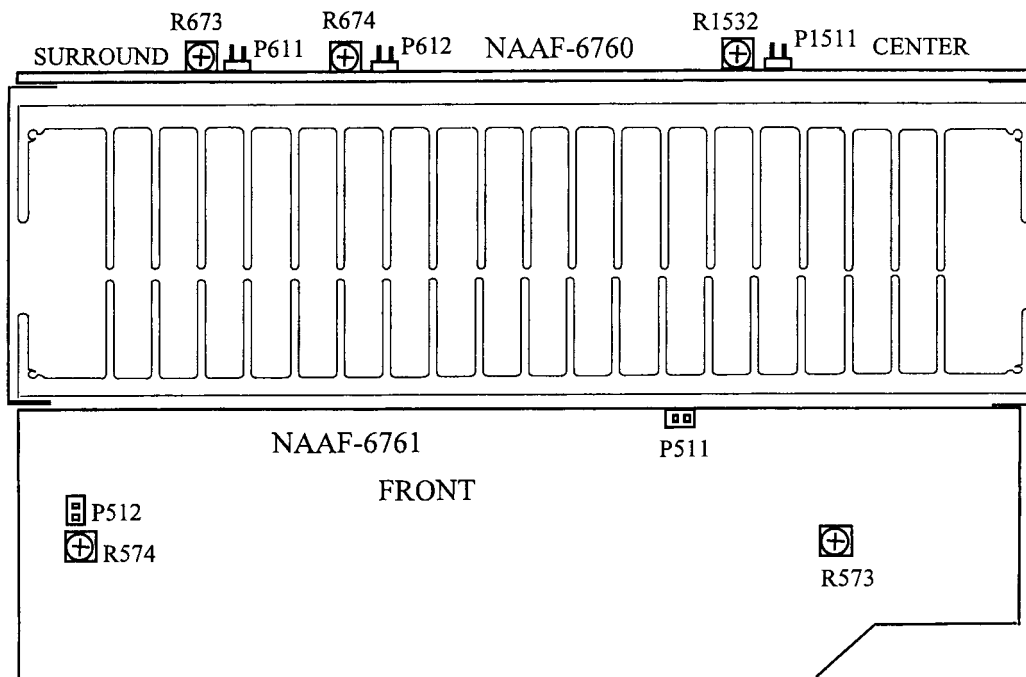

Confirmation of protection circuit

1. Confirmation of operation of speaker relay

Confirm that the speaker relay turns ON approximate. 5 seconds after the power switch is turned ON.
Confirm that the speaker relay turns OFF immediately after the power switch is turned OFF.

2. Confirmation of DC detection circuit

Press and hold down CD button, then press SPEAKERS-A and SPEAKERS-B buttons at the same time.
During "TEST-" on the FL tube is displayed, press DVD button. Next, press CD button.(Refer to Test mode.)
Apply DC 1.5~3V to MULTI CHANNEL INPUT terminals with no load.
Confirm that the speaker relay turns OFF.
Apply DC -1.5~-3V to MULTI CHANNEL INPUT terminals with no load.
Confirm that the speaker relay turns OFF.

3. Confirmation of Current detection circuit

Press and hold down CD button, then press SPEAKERS-A and SPEAKERS-B buttons at the same time.
During "TEST-" on the FL tube is displayed, press DVD button. Next, press CD button.
Connect Differential circuit and apply the 50Hz square signal to the terminal of MULTI CHANNEL INPUT.
Adjust the attenuator or Volume so that the output level becomes 30V p-p.
Confirm that the speaker relay turns OFF when a 1.5 ohm load is connected.

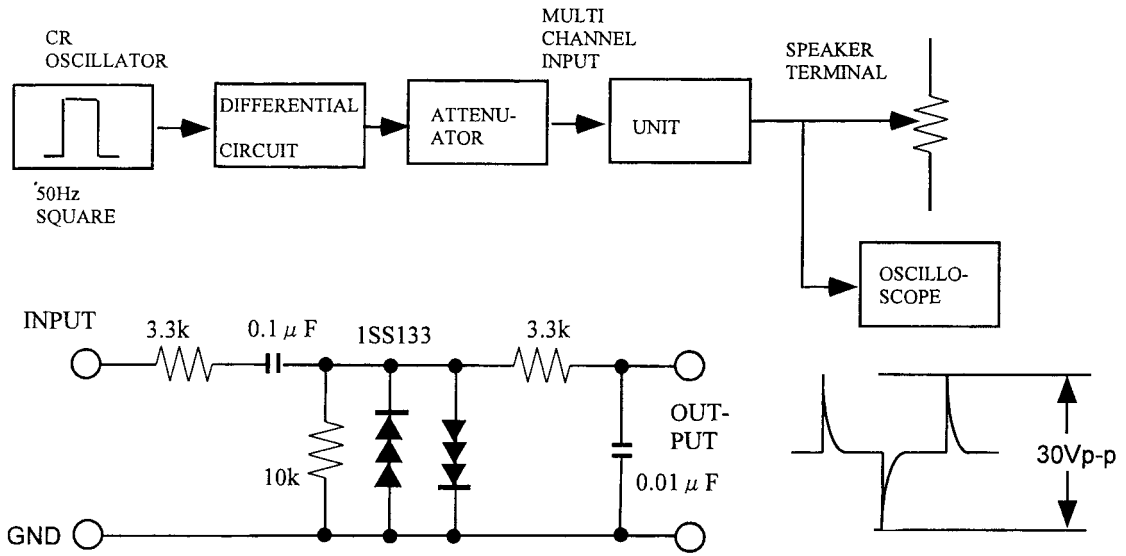

Test Mode Differential Circuit

1. Turn POWER button on.
2. Press and hold down CD button, then press SPEAKERS-A and SPEAKERS-B buttons at the same time.
3. During "TEST-" on the FL tube is displayed, press CD, DVD, VIDEO 1, or VIDEO 2 button to set the unit to the test mode shown below.
4. Press CD or PHONO button to select the test item.

Button Operation in the Test Mode

Button Operation	Test Mode
CD	TEST-0
DVD	TEST-1
VIDEO 1	TEST-2
VIDEO 2	TEST-3
CD	UP of item
PHONO	DOWN of item

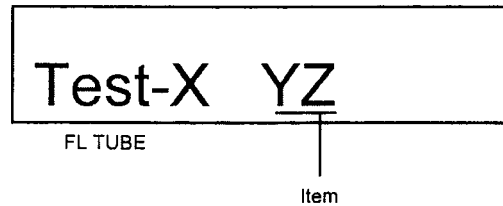

TEST-0

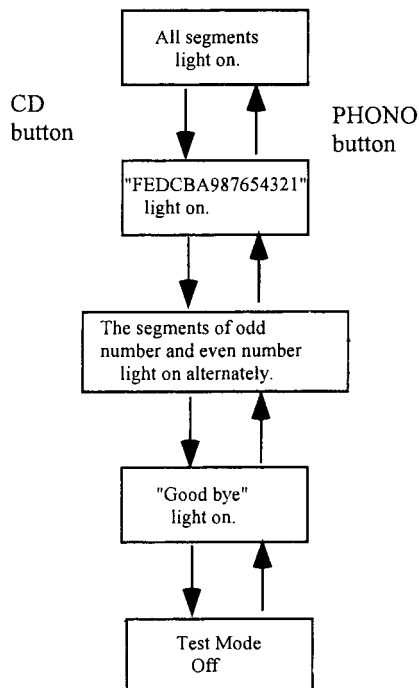

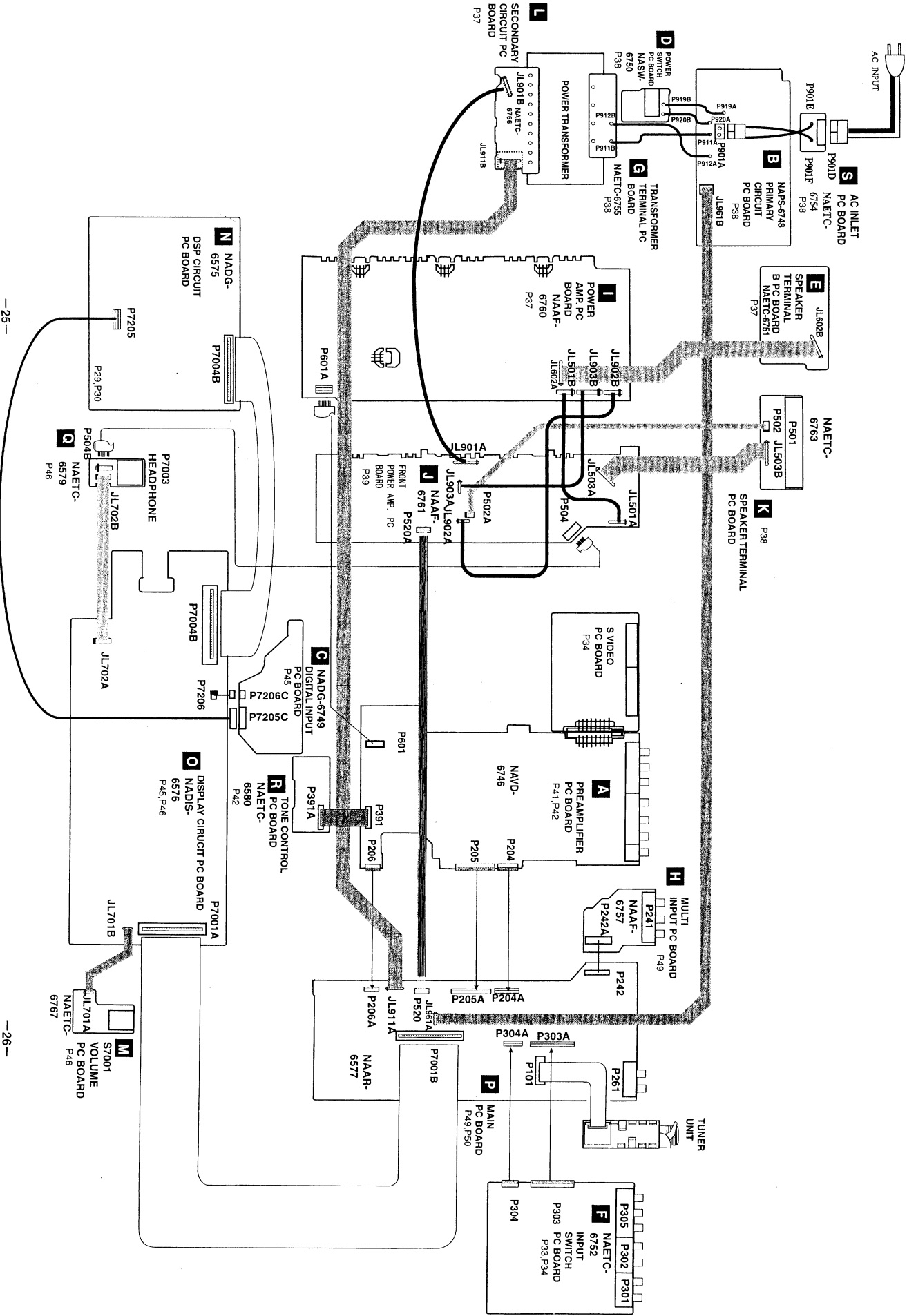

A B C D E F G

BLOCK DIAGRAM

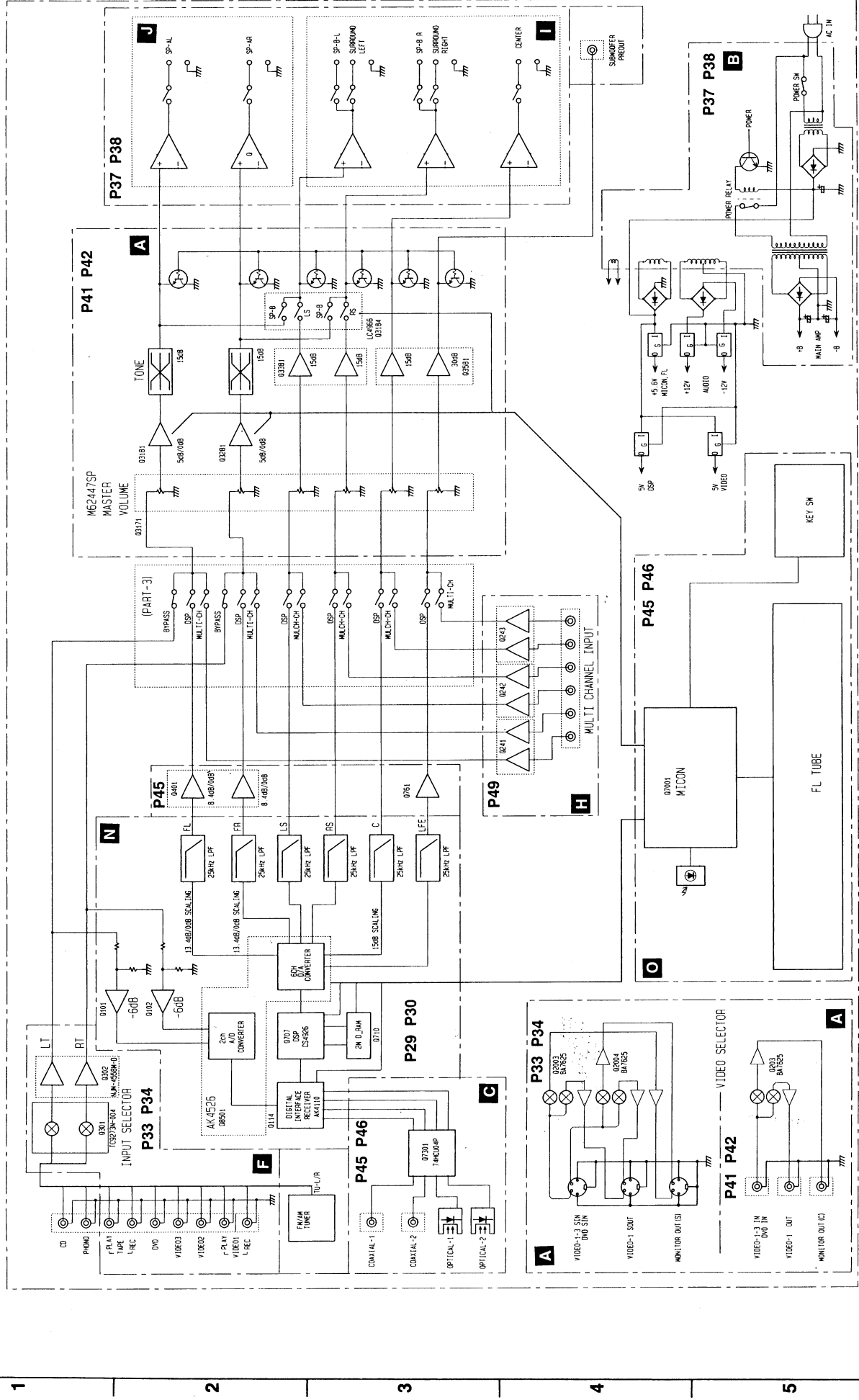

SCHEMATIC DIAGRAM 1

MA06-5575-*

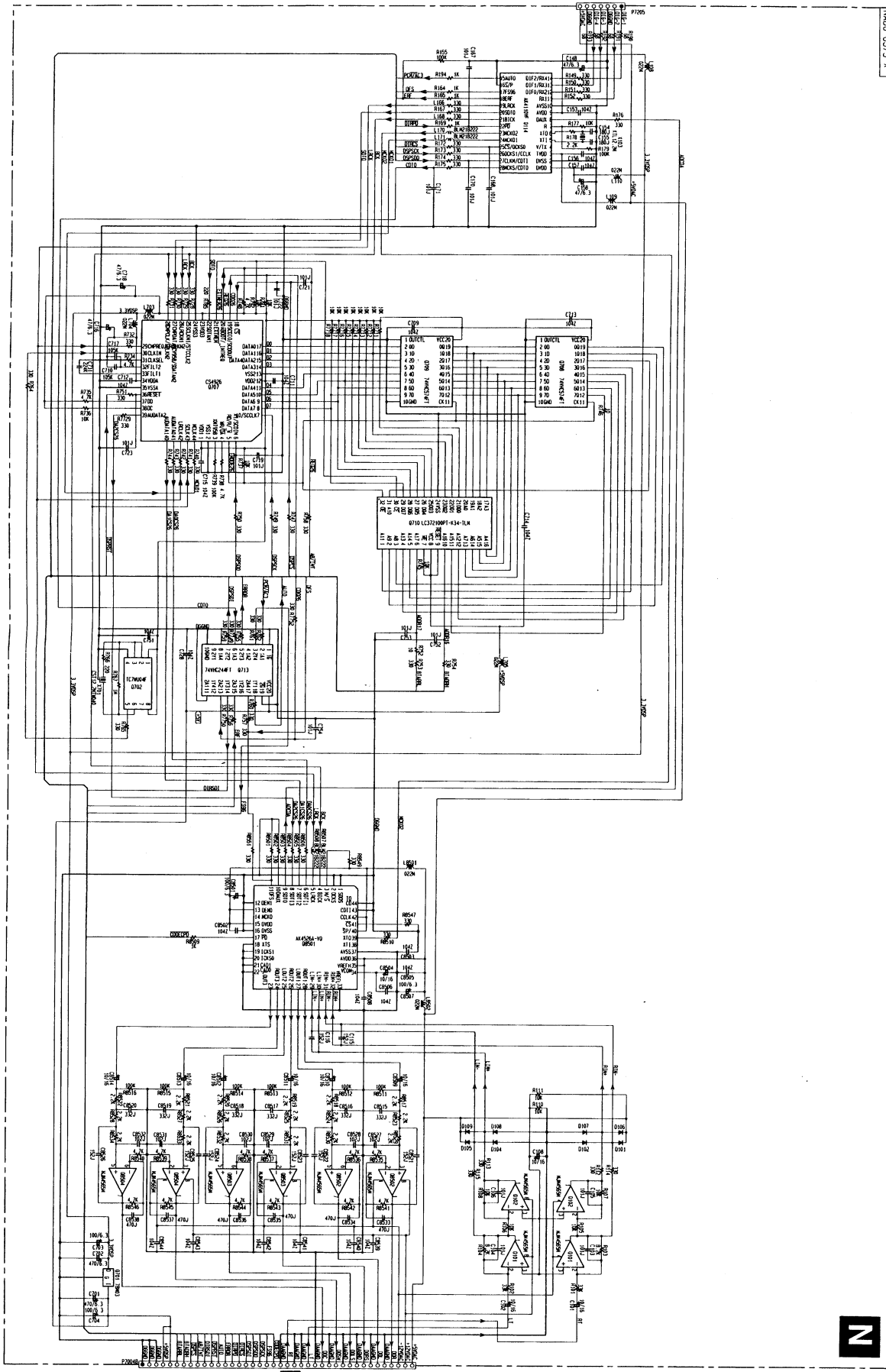

A B C D E F G

DTR-5.1 DTR-5.1

N

P45

P45

5

4

3

2

1

G

F

E

D

C

B

A

SCHEMATIC DIAGRAM 2

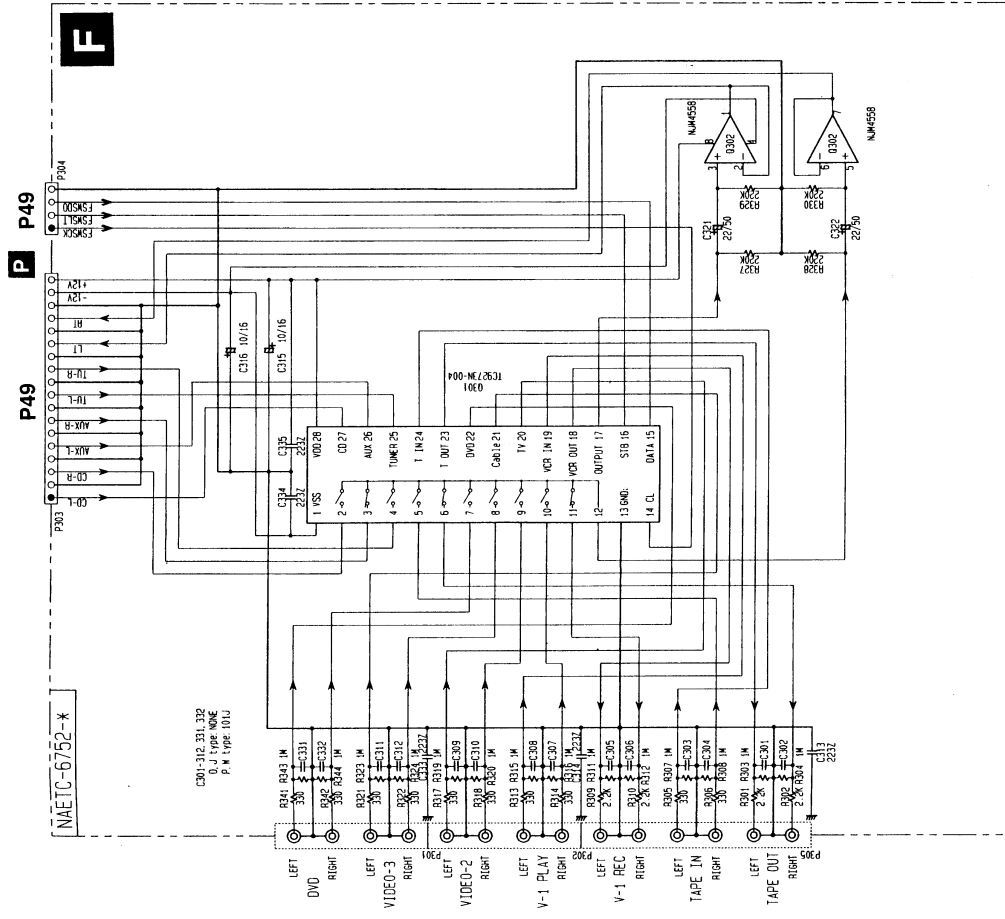
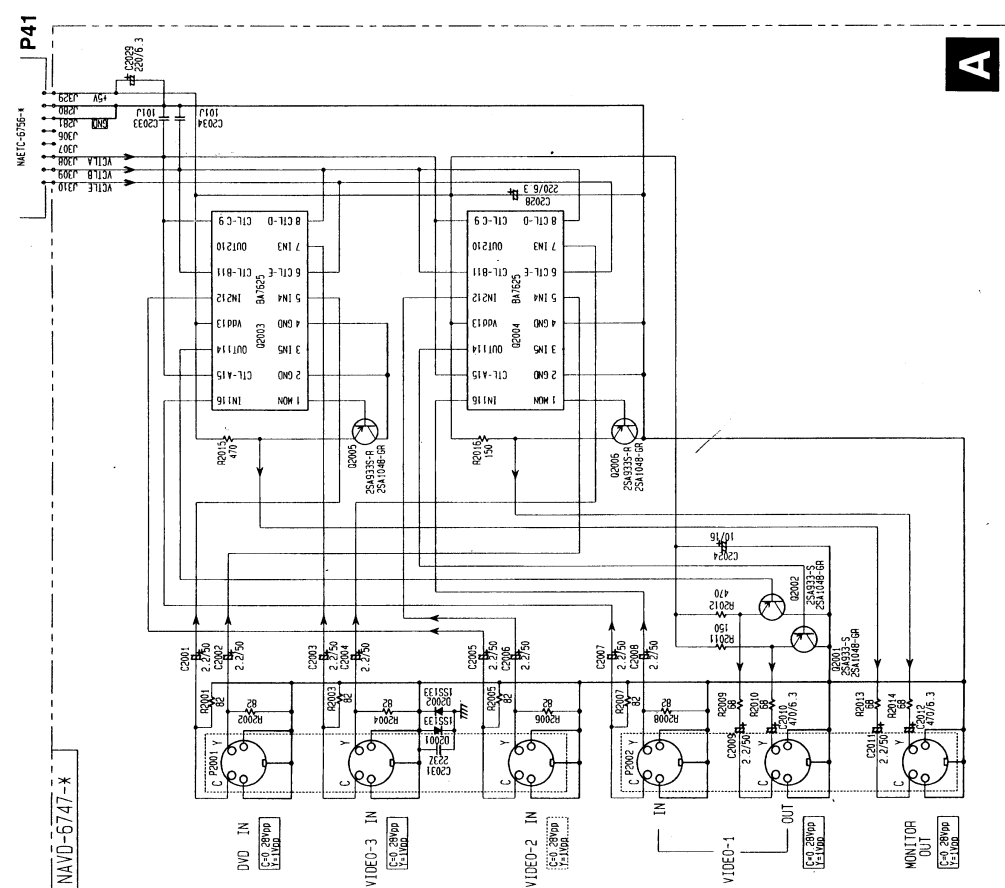

1

2

3

4

5

A B C D E F G

SCHEMATIC DIAGRAM 3

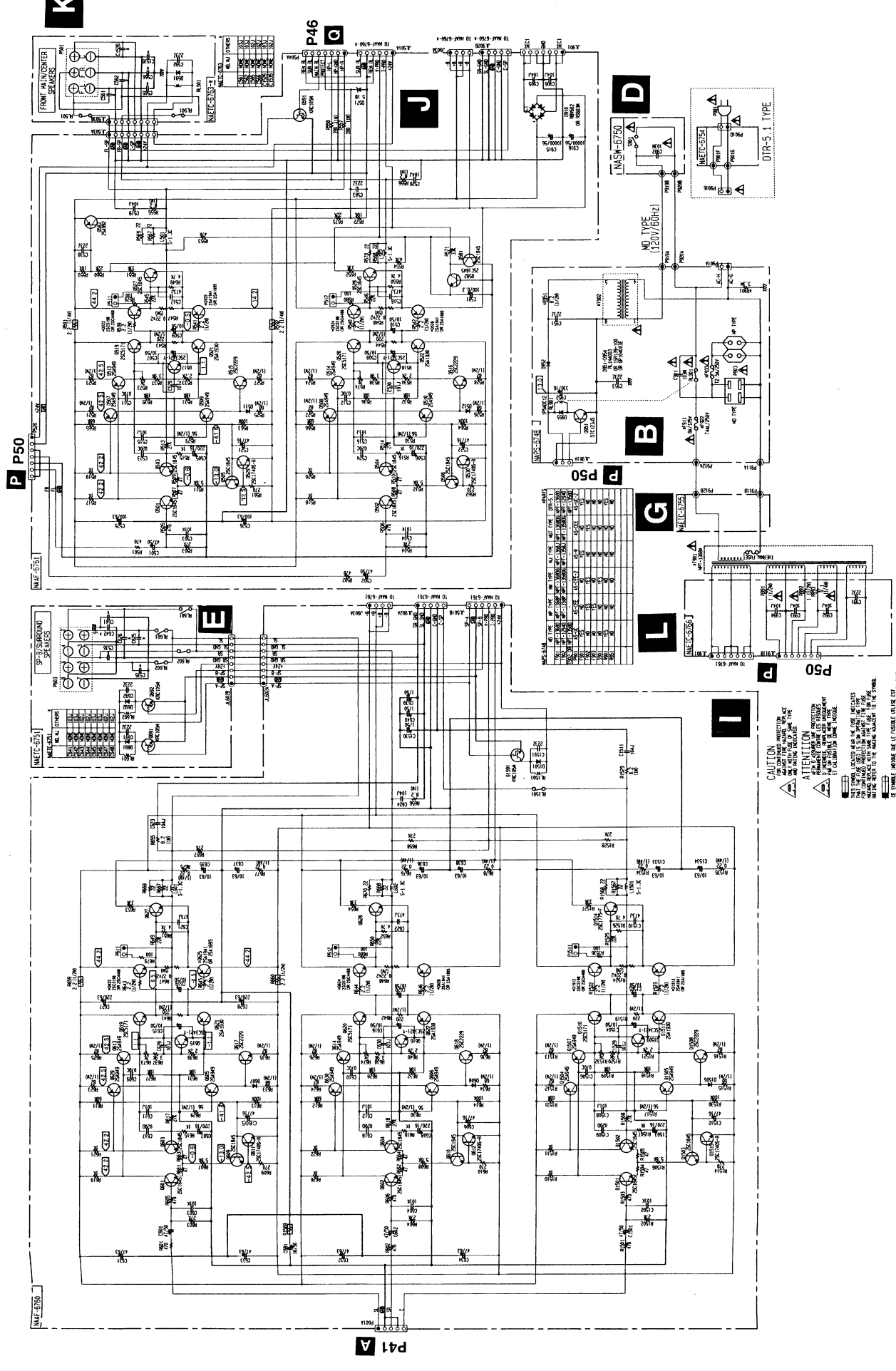

1 2 3 4 5

A B C D E F G

SCHEMATIC DIAGRAM 4

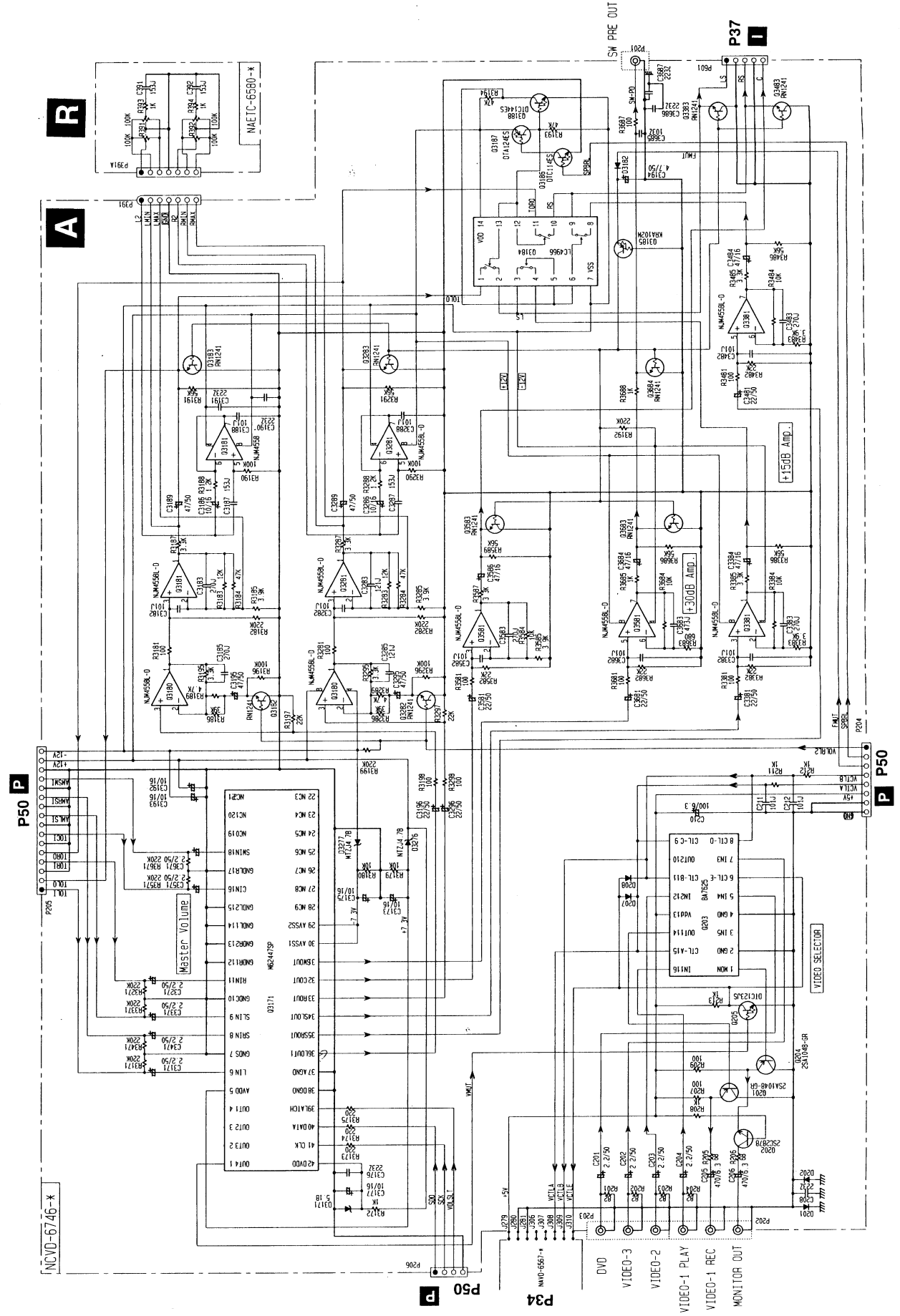

A

R

P50 P

NCVD-674G-X

P50

P50

P50

P50

P50

P50

P50

P50

P50

P50

P50

P50

P50

P50

P50

P50

P50

P50

P50

P50

P50

P50

P50

P50

P50

P50

P50

P50

P50

P50

P50

P50

P50

P50

P50

P50

P50

P50

P50

P50

P50

P50

P50

P50

P50

P50

P50

P50

P50

P50

P50

P50

P50

P50

P50

P50

P50

P50

P50

P50

P50

P50

P50

P50

P50

P50

P50

P50

P50

P50

P50

P50

P50

P50

P50

P50

P50

P50

P50

P50

P50

P50

P50

P50

P50

P50

P50

P50

P50

P50

P50

P50

P50

P50

P50

P50

P50

P50

P50

P50

P50

P50

P50

P50

P50

P50

P50

P50

P50

P50

P50

P50

P50

P50

P50

P50

P50

P50

P50

P50

P50

P50

P50

P50

P50

P50

P50

P50

P50

P50

P50

P50

P50

P50

P50

P50

P50

P50

P50

P50

P50

P50

P50

P50

P50

P50

P50

P50

P50

P50

P50

P50

P50

P50

P50

P50

P50

P50

P50

P50

P50

P50

P50

P50

P50

A B C D E F G

SCHEMATIC DIAGRAM 6

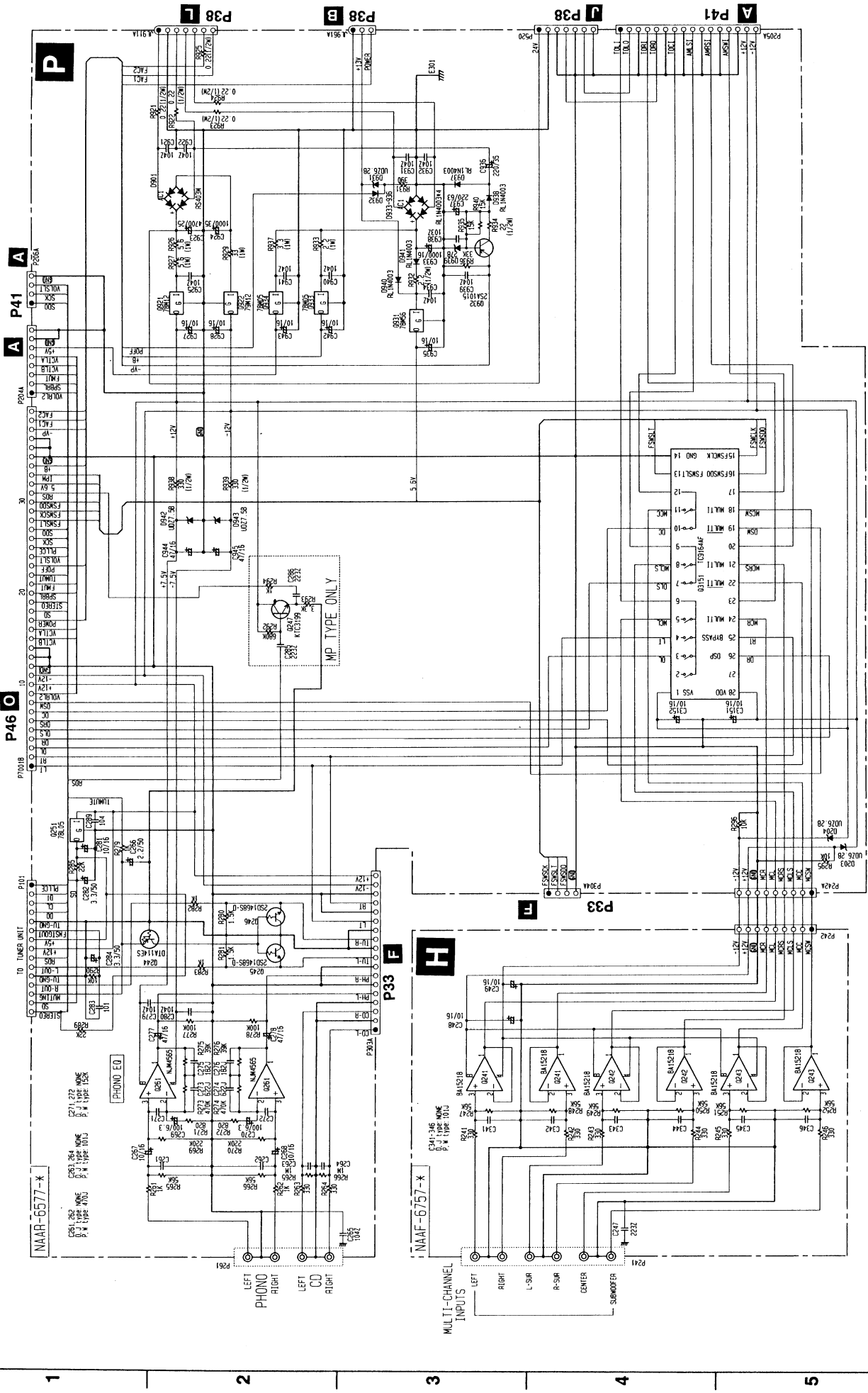

EXPLODED VIEW

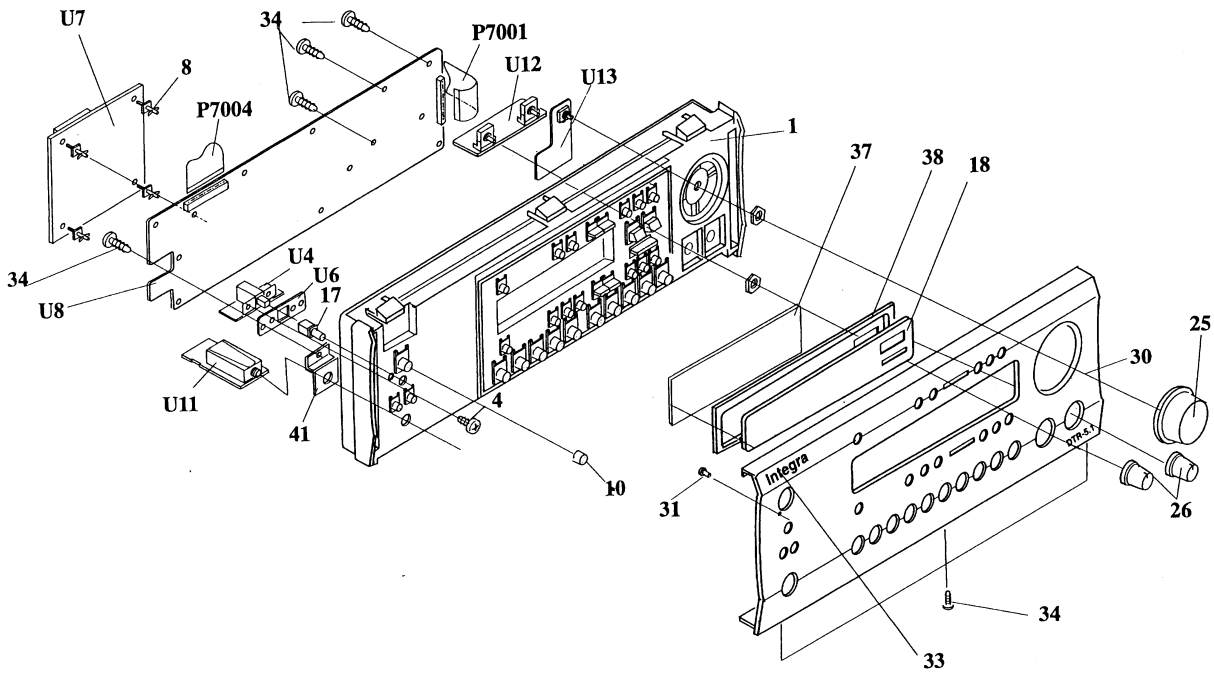

—51—

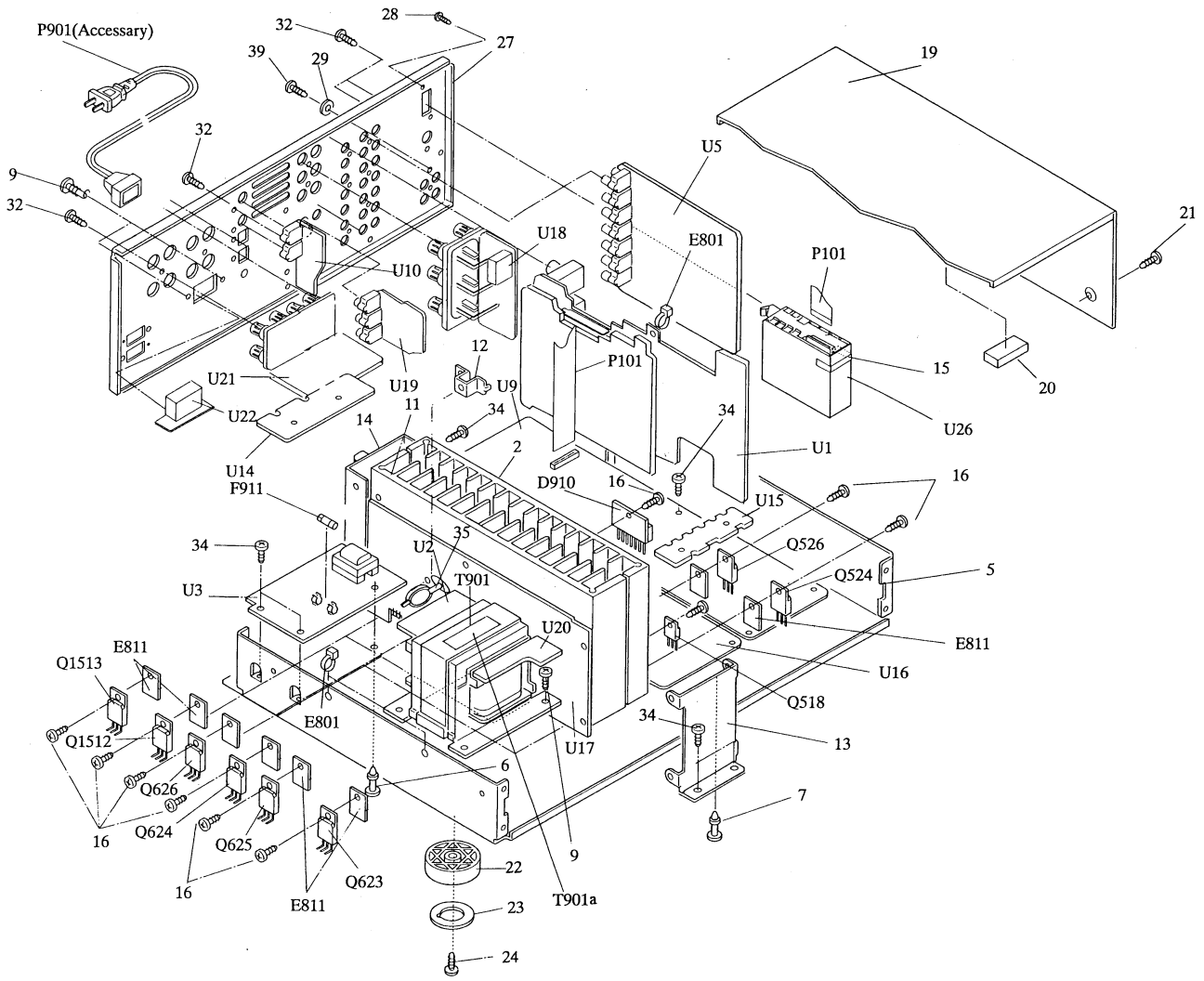

—52—

DTR-5.1
DTR-5.1

PARTS LIST

REF.NO.	PART NO.	DESCRIPTION	REF.NO.	PART NO.	DESCRIPTION
1	27111163	Front bracket	D910	22380038 or 22380274	RBV602 or RS603M, Diode
2	27160439	Heat sink S	E801	260208	Wire tie
4	82143010	3P+10FN(BC),Pan head screw	E811	223024Y	AC238, Isolated sheet
5	27100371A	Chassis	F911	252198Y	8A-UL, Primary fuse
6	27190266	KGLS-12RF Holder	P101	2047152012	NCFC7-152012,Flexible flat cable
7	27190428A	KGLS-10RF,Holder	P7001	2047402512	NCFC7-402512, Flexible flat cable
8	27190896	KGLS-10S,Holder	P7004	2047401512	NCFC7-401512,Flexible flat cable
9	830440089	4TTC+8C(BC),Self-tapping screw	P901	253193HIT or 253195MAR	AS-CEE, or AS CEE, Power supply cord
10	28325756	Knob, standby	Q1512	2203063,	* 2SC5198-O,
11	27160438	Heat sink L	Q523	2202523,	* 2SC4468-O,
12	27141681	Retainer PWB	Q524	2202524,	* 2SC4468-Y,
13	27141736	Retainer, front	Q623	2202526 or	* 2SC4468-P or
14	27141737	Retainer, rear	Q624	2203062	* 2SC5198-R,Transistor
15	29110083	Tape, cloth	Q1513	2203053,	* 2SA1941-O,
16	801433	3SMS8W,SW+14B(BC), Special screw	Q525	2202513,	* 2SA1695-O,
17	28325753	Knob, power	Q526	2202514,	* 2SA1695-Y,
18	28191884	Clear plate	Q625	2202516 or	* 2SA1695-P or
19	28184752	Top cover	Q626	2203052	* 2SA1941-R,Transistor
20	28141272Y	t 10x60x20, Cushion	Q517	2212654 or	2SC3421-Y or
21	838430088	3TTB+8B(BC),Self-tapping screw	Q518	2212653	2SC3421-O, Transistor
22	27175319A	Leg	T901	2301405	NPT-1368D,Power transformer
23	28141332	Cushion	T901a	29362609	Label PT
24	831430088	3TTW+8B(BC),Self-tapping screw	U1	1A873546-1F	NAVD-6746-1F,Pre., amplifier PC board assy
25	28325757	Knob, volume	U2	1A873555-1F	NAETC-6755-1F,Transformer terminal PC board assy
26	28325405	Knob, tone	U3	1A873548-1F	NAPS-6748-1F,Primary circuit PC board assy
27	27122721A	Rear panel	U4	1A873550-1F	NASW-6750-1F,Power switch PC board assy
28	838430068	3TTB+6B(BC),Self-tapping screw	U5	1A873552-1F	NAETC-6752-1F,Input switch PC board assy
29	87643010	W3*10F(BC),Flat washer	U6	25136753	NCETC-6753,PC board for holder
30	27212203A	Front panel	U7	1A873575-6C	NADG-6575-6C,DSP circuit PC board assy
31	28198905	Facet	U8	1A873576-3F	NADIS-6576-3F,Display circuit PC board assy
32	838430088	3TTB+8B(BC),Self-tapping screw	U9	1A873577-3F	NAAR-6577-3F,Main PC board assy
33	28135278	Badge	U10	1A873549-1F	NADG-6749-1F, Digital input PC board assy
34	838130088	3TTB+8B, Self-tapping screw	U11	1A873579-3F	NAETC-6579-3F,Headphone terminal PC board assy
35	27190807	Holder	U12	1A873580-3F	NAETC-6580-3F, Tone control PC board assy
36	27190541	WS-1NS, Wire clamp	U13	1A873567-1C	NAETC-6767-1C,Volume control PC board assy
37	28133387	Back plate	U14	25136765	NCETC-6765,PC board for lead wire
38	27191105	Holder	U15	25136764	NCETC-6764,PC board for lead wire
39	838930088	3TTB+8B(UN),Self-tapping screw	U16	1A873561-1C	NAAF-6761-1C,Front channel power amplifier PC board assy
40	27190608-1	Holder	U17	1A873560-1C	NAAF-6760-1C,Power amplifier PC board assy
41	27141756	Retainer HP	U18	1A873563-1C	NAETC-6763-1C,Speaker terminal PC board assy
			U19	1A873557-1F	NAAF-6757-1F, Multi-channel input terminal PC board assy
			U20	1A873566-1C	NAETC-6766-1C,Secondary circuit PC board assy
			U21	1A873551-1C	NAETC-6751-1C,Speaker terminal B PC board assy
			U22	1A873554-1C	NAETC-6754-1C,AC inlet terminal PC board assy
			U26	240134	TFCE1U114A,Tuner unit

CAUTION: Replacement for transistor of mark *, if necessary must be made from the same beta group (HFE) as the original type.

NOTE: THE COMPONENTS IDENTIFIED BY MARK Δ ARE CRITICAL FOR RISK OF FIRE AND ELECTRICAL SHOCK. REPLACE ONLY WITH PART NUMBER SPECIFIED.

PACKING VIEW

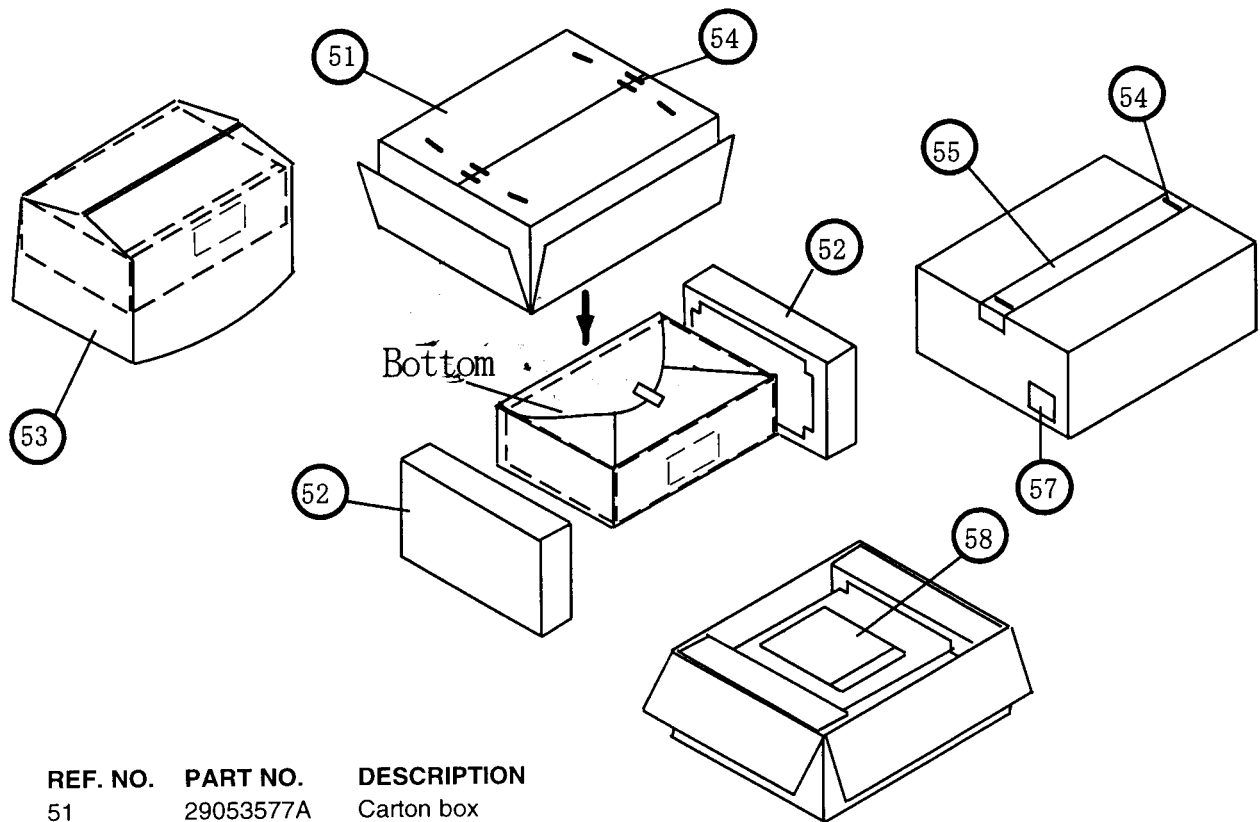

REF. NO.	PART NO.	DESCRIPTION
51	29053577A	Carton box
52	29091844-1	Pad
53	29095886	1180x650,Protection sheet
54	282301	Staple
55	29110071	PP tape
57	29362610	Label UPC
58	29100097-1A	350*250,Polybag
	29365080B	Warranty card
	29095865	Sheet, warranty
	29342866	Instruction manual
	29342867	Instruction sheet
	24140424A	RC-424M,Remote controller
	3010054	UM-3,Two batteries
	292142	FM antenna
	232140	NMA-3057,AM loop antenna
	253297KAW	AS-UC-2,Power supply cord

Integra Division of
 ONKYO U.S.A. CORPORATION
 200 Williams Drive, Ramesy, N.J. 07446, U.S.A.
 Tel: 201-825-7950 Fax: 201-825-8150 E-mail: integra@onkyousa.com

Integra Division of
 ONKYO CORPORATION
 Sales & Product Planning Div. :
 2-1, Nisshin-cho, Neyagawa-shi, OSAKA 572-8540, JAPAN
 Tel: 072-831-8111 Fax: 072-833-5222