

ONKYO SERVICE MANUAL

Ref. No. 4149
072009 (CDC1N)

BLU-RAY DISC PLAYER MODEL DV-BD507(B)CDC1N

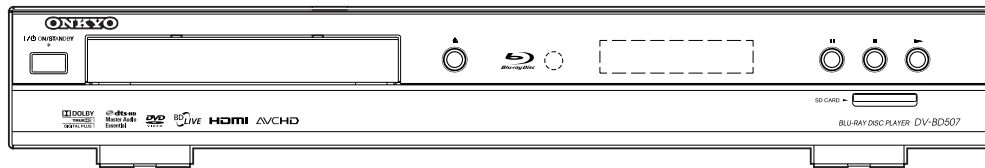

Black model



RC-730DV

B CDC1N	120 V AC, 60Hz
---------	----------------

SAFETY-RELATED COMPONENT WARNING!!

COMPONENTS IDENTIFIED BY MARK  ON THE SCHEMATIC DIAGRAM AND IN THE PARTS LIST ARE CRITICAL FOR RISK OF FIRE AND ELECTRIC SHOCK. REPLACE THESE COMPONENTS WITH ONKYO PARTS WHOSE PART NUMBERS APPEAR AS SHOWN IN THIS MANUAL.

MAKE LEAKAGE-CURRENT OR RESISTANCE MEASUREMENTS TO DETERMINE THAT EXPOSED PARTS ARE ACCEPTABLY INSULATED FROM THE SUPPLY CIRCUIT BEFORE RETURNING THE APPLIANCE TO THE CUSTOMER.

ONKYO
IMAGINATIVE SIGHT & SOUND

TABLE OF CONTENTS

Specifications	1-1-1
Laser Beam Safety Precautions	1-2-1
Important Safety Precautions	1-3-1
Standard Notes for Servicing	1-4-1
Cabinet Disassembly Instructions	1-5-1
How to Initialize the BLU-RAY Disc Player	1-6-1
Firmware Renewal Mode	1-7-1
Block Diagrams	1-8-1
Schematic Diagrams / CBA and Test Points	1-9-1
Exploded Views	1-10-1
Mechanical Parts List	1-11-1
Electrical Parts List	1-12-1

Manufactured under license from Dolby Laboratories.
Dolby and the double-D symbol are trademarks of Dolby Laboratories.

SPECIFICATIONS

General	
Signal system	NTSC color
Power requirements	120V AC, 60Hz
Power consumption	22W (standby: 0.7W)
Dimensions (width x height x depth)	17 ^{-1/8} x 2 ^{-3/4} x 12 ^{-3/16} inches (435 x 69.3 x 310mm)
Weight	6.6 lbs (3.0kg)
Operating temperature	41°F (5°C) to 104°F (40°C)
Operating humidity	Less than 80% (no condensation)

Terminals		
Rear	Audio output (Analog)	
	RCA jack x 2	L/R: 2Vrms (output impedance: more than 1kΩ)
	Video output	
	RCA jack x 1	1Vp-p (75Ω)
	Component video output	
	RCA jack x 3	Y: 1Vp-p (75Ω) PB: 700mVp-p (75Ω) PR: 700mVp-p (75Ω)
	Audio output (Digital)	
	RCA jack x 1	500mVp-p (75Ω)
	Optical jack x 1	Digital connector
	HDMI output	
HDMI jack x 1	Video: 480p, 720p, 1080i, 1080p, 1080p24 / Audio	
ETHERNET terminal	10BASE-T/100BASE-TX	

Note

- The specifications and design of this product are subject to change without notice.

LASER BEAM SAFETY PRECAUTIONS

This BD player uses a pickup that emits a laser beam.

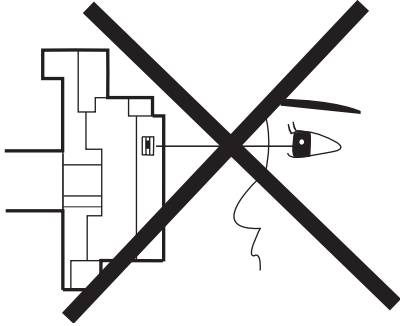

Do not look directly at the laser beam coming from the pickup or allow it to strike against your skin.

The laser beam is emitted from the location shown in the figure. When checking the laser diode, be sure to keep your eyes at least 30 cm away from the pickup lens when the diode is turned on. Do not look directly at the laser beam.

CAUTION: Use of controls and adjustments, or doing procedures other than those specified herein, may result in hazardous radiation exposure.

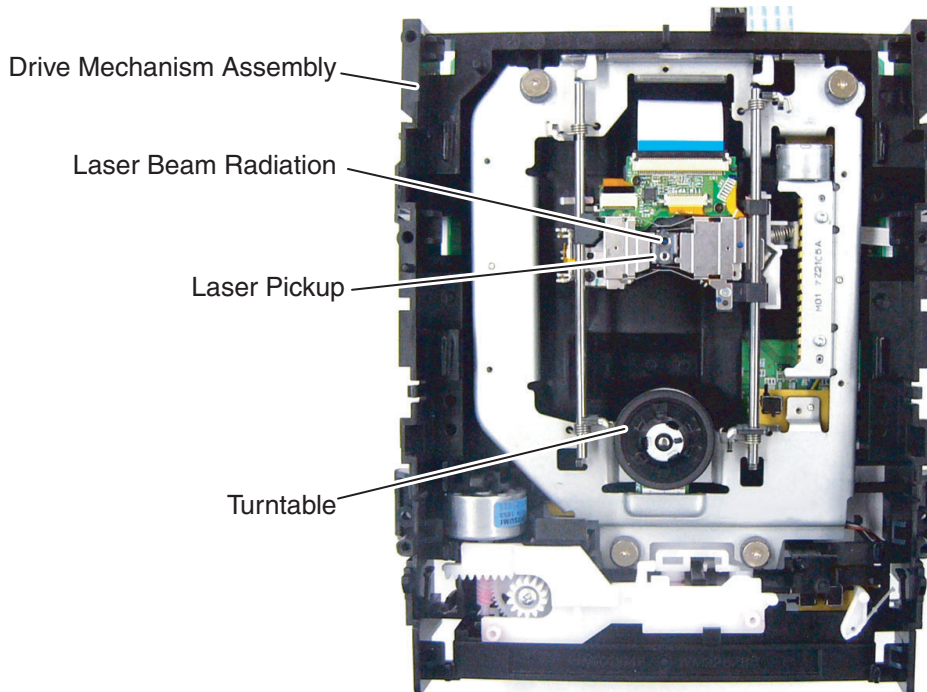

CAUTION - LASER RADIATION WHEN OPEN.
DO NOT STARE INTO BEAM. (FDA 21CFR/Class II)

CAUTION - CLASS 2 LASER RADIATION WHEN OPEN
DO NOT STARE INTO THE BEAM (IEC60825-1/Class 2)

ATTENTION - RAYONNEMENT LASER DE CLASSE 2 EN CAS D'OUVERTURE
NE PAS REGARDER DANS LE FAISCEAU

注意 - ここを覗くとクラス2のレーザー放射が出る
ビームをのぞき込まないこと

Location: Inside Top of BD mechanism.

IMPORTANT SAFETY PRECAUTIONS

Product Safety Notice

Some electrical and mechanical parts have special safety-related characteristics which are often not evident from visual inspection, nor can the protection they give necessarily be obtained by replacing them with components rated for higher voltage, wattage, etc. Parts that have special safety characteristics are identified by a **▲** on schematics and in parts lists. Use of a substitute replacement that does not have the same safety characteristics as the recommended replacement part might create shock, fire, and/or other hazards. The Product's Safety is under review continuously and new instructions are issued whenever appropriate. Prior to shipment from the factory, our products are carefully inspected to confirm with the recognized product safety and electrical codes of the countries in which they are to be sold. However, in order to maintain such compliance, it is equally important to implement the following precautions when a set is being serviced.

- I. Also check areas surrounding repaired locations.
- J. Be careful that foreign objects (screws, solder droplets, etc.) do not remain inside the set.
- K. When connecting or disconnecting the internal connectors, first, disconnect the AC plug from the AC outlet.

Precautions during Servicing

- A. Parts identified by the **▲** symbol are critical for safety. Replace only with part number specified.
- B. In addition to safety, other parts and assemblies are specified for conformance with regulations applying to spurious radiation. These must also be replaced only with specified replacements. Examples: RF converters, RF cables, noise blocking capacitors, and noise blocking filters, etc.
- C. Use specified internal wiring. Note especially:
 - 1) Wires covered with PVC tubing
 - 2) Double insulated wires
 - 3) High voltage leads
- D. Use specified insulating materials for hazardous live parts. Note especially:
 - 1) Insulation tape
 - 2) PVC tubing
 - 3) Spacers
 - 4) Insulators for transistors
- E. When replacing AC primary side components (transformers, power cord, etc.), wrap ends of wires securely about the terminals before soldering.
- F. Observe that the wires do not contact heat producing parts (heat sinks, oxide metal film resistors, fusible resistors, etc.).
- G. Check that replaced wires do not contact sharp edges or pointed parts.
- H. When a power cord has been replaced, check that 5 - 6 kg of force in any direction will not loosen it.

Safety Check after Servicing

Examine the area surrounding the repaired location for damage or deterioration. Observe that screws, parts, and wires have been returned to their original positions. Afterwards, do the following tests and confirm the specified values to verify compliance with safety standards.

1. Clearance Distance

When replacing primary circuit components, confirm specified clearance distance (d) and (d') between soldered terminals, and between terminals and surrounding metallic parts. (See Fig. 1)

Table 1: Ratings for selected area

AC Line Voltage	Clearance Distance (d), (d')
120 V	$\geq 3\text{mm}(d)$ $\geq 4\text{mm}(d')$

Note: This table is unofficial and for reference only. Be sure to confirm the precise values.

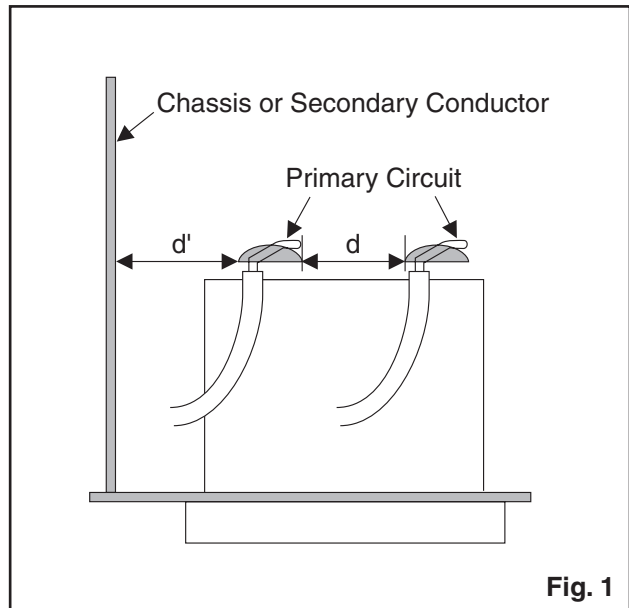

Fig. 1

2. Leakage Current Test

Confirm the specified (or lower) leakage current between B (earth ground, power cord plug prongs) and externally exposed accessible parts (RF terminals, antenna terminals, video and audio input and output terminals, microphone jacks, earphone jacks, etc.) is lower than or equal to the specified value in the table below.

Measuring Method (Power ON):

Insert load Z between B (earth ground, power cord plug prongs) and exposed accessible parts. Use an AC voltmeter to measure across the terminals of load Z. See Fig. 2 and the following table.

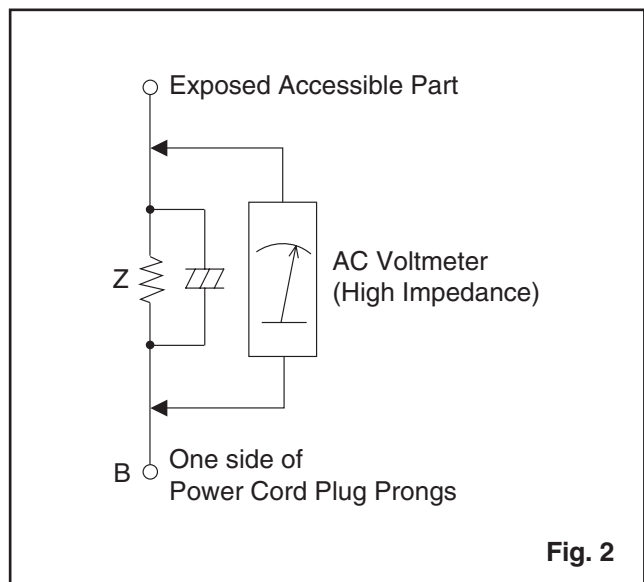

Fig. 2

Table 2: Leakage current ratings for selected areas

AC Line Voltage	Load Z	Leakage Current (i)	One side of power cord plug prongs (B) to:
120 V	2k Ω RES. Connected in parallel	$i \leq 0.7\text{mA AC Peak}$ $i \leq 2\text{mA DC}$	RF or Antenna terminals
	50k Ω RES. Connected in parallel	$i \leq 0.7\text{mA AC Peak}$ $i \leq 2\text{mA DC}$	A/V Input, Output

Note: This table is unofficial and for reference only. Be sure to confirm the precise values.

STANDARD NOTES FOR SERVICING

Circuit Board Indications

1. The output pin of the 3 pin Regulator ICs is indicated as shown.

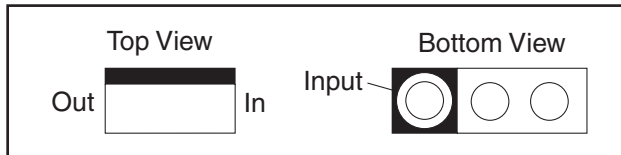

2. For other ICs, pin 1 and every fifth pin are indicated as shown.

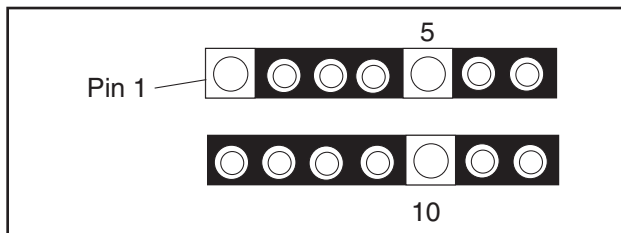

3. The 1st pin of every male connector is indicated as shown.

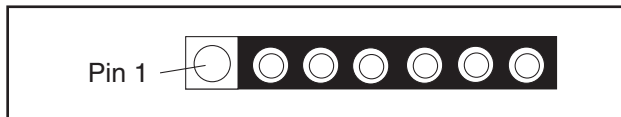

Instructions for Connectors

1. When you connect or disconnect the FFC (Flexible Foil Connector) cable, be sure to first disconnect the AC cord.
2. FFC (Flexible Foil Connector) cable should be inserted parallel into the connector, not at an angle.

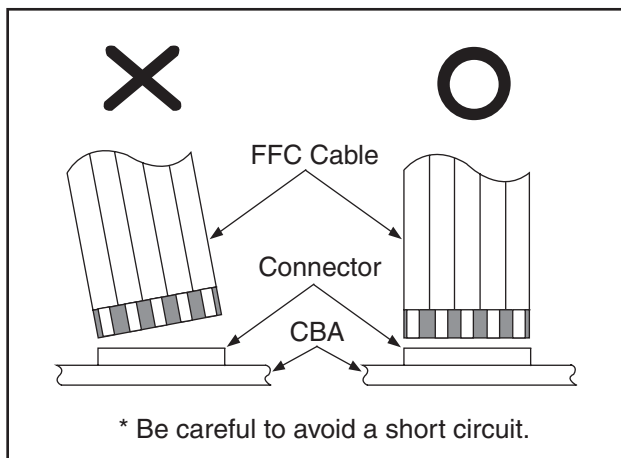

Pb (Lead) Free Solder

When soldering, be sure to use the Pb free solder.

How to Remove / Install Flat Pack-IC

1. Removal

With Hot-Air Flat Pack-IC Desoldering Machine:

1. Prepare the hot-air flat pack-IC desoldering machine, then apply hot air to the Flat Pack-IC (about 5 to 6 seconds). (Fig. S-1-1)

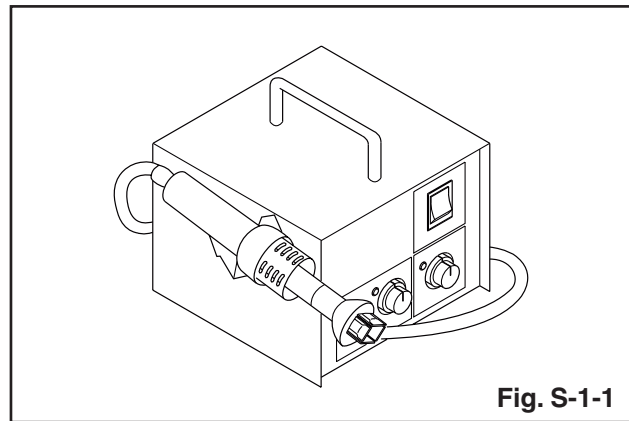

2. Remove the flat pack-IC with tweezers while applying the hot air.
3. Bottom of the flat pack-IC is fixed with glue to the CBA; when removing entire flat pack-IC, first apply soldering iron to center of the flat pack-IC and heat up. Then remove (glue will be melted). (Fig. S-1-6)
4. Release the flat pack-IC from the CBA using tweezers. (Fig. S-1-6)

CAUTION:

1. The Flat Pack-IC shape may differ by models. Use an appropriate hot-air flat pack-IC desoldering machine, whose shape matches that of the Flat Pack-IC.
2. Do not supply hot air to the chip parts around the flat pack-IC for over 6 seconds because damage to the chip parts may occur. Put masking tape around the flat pack-IC to protect other parts from damage. (Fig. S-1-2)

3. The flat pack-IC on the CBA is affixed with glue, so be careful not to break or damage the foil of each pin or the solder lands under the IC when removing it.

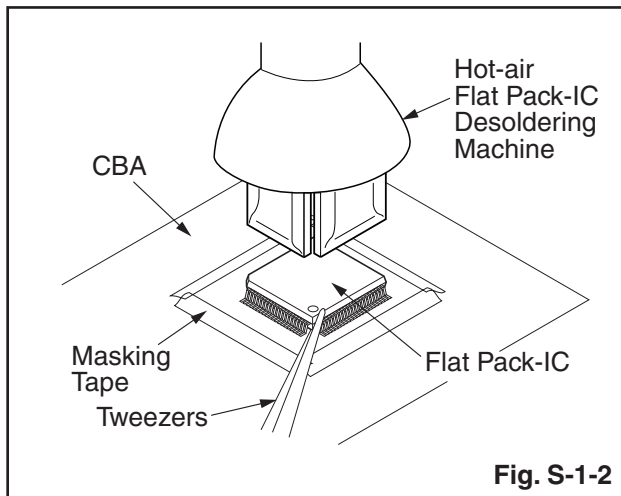

With Soldering Iron:

1. Using desoldering braid, remove the solder from all pins of the flat pack-IC. When you use solder flux which is applied to all pins of the flat pack-IC, you can remove it easily. (Fig. S-1-3)

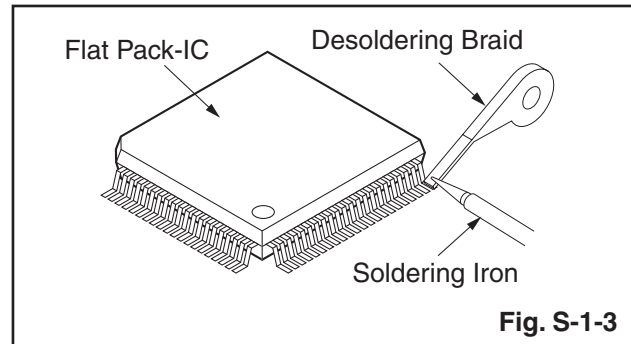

2. Lift each lead of the flat pack-IC upward one by one, using a sharp pin or wire to which solder will not adhere (iron wire). When heating the pins, use a fine tip soldering iron or a hot air desoldering machine. (Fig. S-1-4)

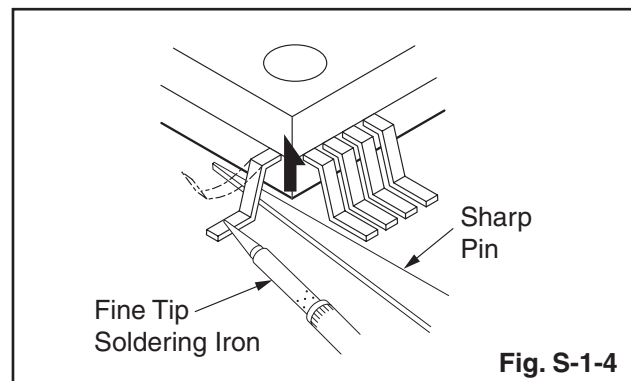

3. Bottom of the flat pack-IC is fixed with glue to the CBA; when removing entire flat pack-IC, first apply soldering iron to center of the flat pack-IC and heat up. Then remove (glue will be melted). (Fig. S-1-6)
4. Release the flat pack-IC from the CBA using tweezers. (Fig. S-1-6)

With Iron Wire:

1. Using desoldering braid, remove the solder from all pins of the flat pack-IC. When you use solder flux which is applied to all pins of the flat pack-IC, you can remove it easily. (Fig. S-1-3)
2. Affix the wire to a workbench or solid mounting point, as shown in Fig. S-1-5.
3. While heating the pins using a fine tip soldering iron or hot air blower, pull up the wire as the solder melts so as to lift the IC leads from the CBA contact pads as shown in Fig. S-1-5.
4. Bottom of the flat pack-IC is fixed with glue to the CBA; when removing entire flat pack-IC, first apply soldering iron to center of the flat pack-IC and heat up. Then remove (glue will be melted). (Fig. S-1-6)
5. Release the flat pack-IC from the CBA using tweezers. (Fig. S-1-6)

Note: When using a soldering iron, care must be taken to ensure that the flat pack-IC is not being held by glue. When the flat pack-IC is removed from the CBA, handle it gently because it may be damaged if force is applied.

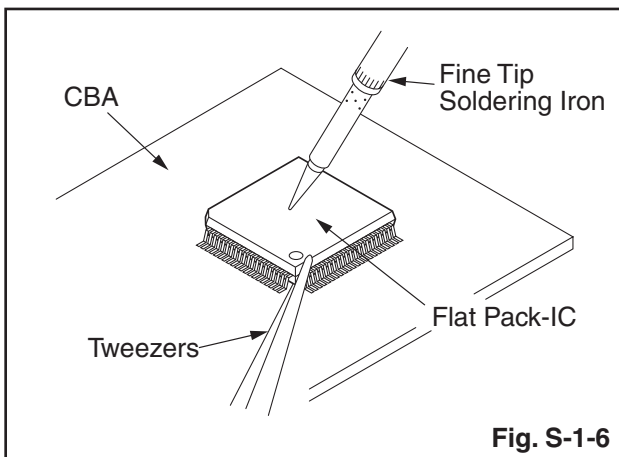
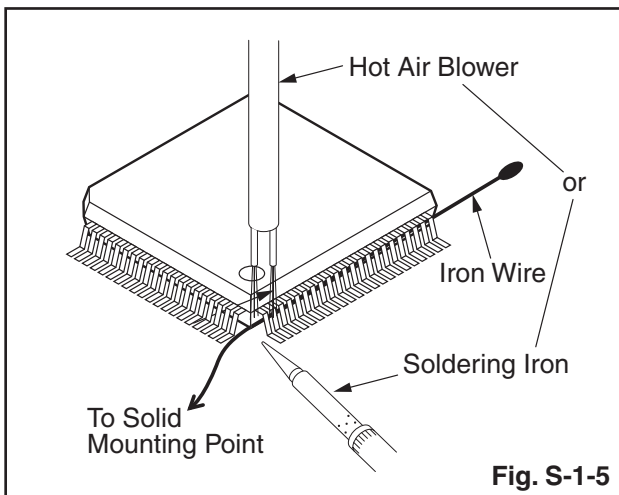

2. Installation

1. Using desoldering braid, remove the solder from the foil of each pin of the flat pack-IC on the CBA so you can install a replacement flat pack-IC more easily.
2. The "●" mark on the flat pack-IC indicates pin 1. (See Fig. S-1-7.) Be sure this mark matches the pin 1 on the PCB when positioning for installation. Then presolder the four corners of the flat pack-IC. (See Fig. S-1-8.)
3. Solder all pins of the flat pack-IC. Be sure that none of the pins have solder bridges.

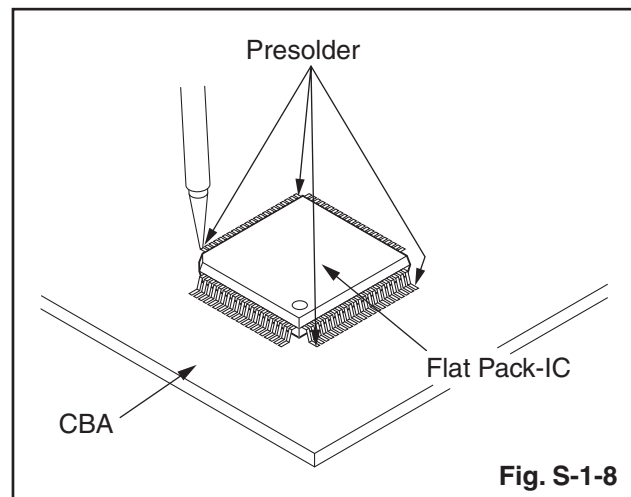
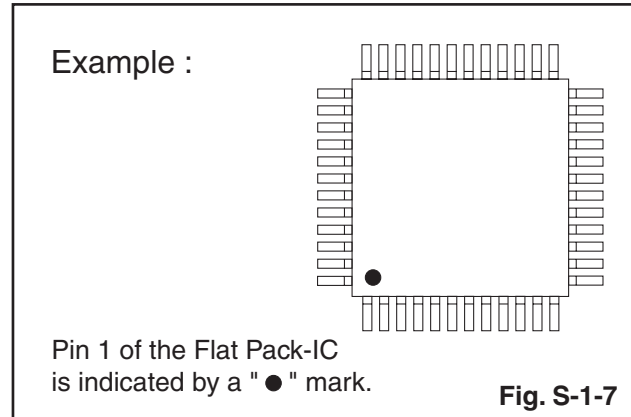

Instructions for Handling Semi-conductors

Electrostatic breakdown of the semi-conductors may occur due to a potential difference caused by electrostatic charge during unpacking or repair work.

1. Ground for Human Body

Be sure to wear a grounding band (1 MΩ) that is properly grounded to remove any static electricity that may be charged on the body.

2. Ground for Workbench

Be sure to place a conductive sheet or copper plate with proper grounding (1 MΩ) on the workbench or other surface, where the semi-conductors are to be placed. Because the static electricity charge on clothing will not escape through the body grounding band, be careful to avoid contacting semi-conductors with your clothing.

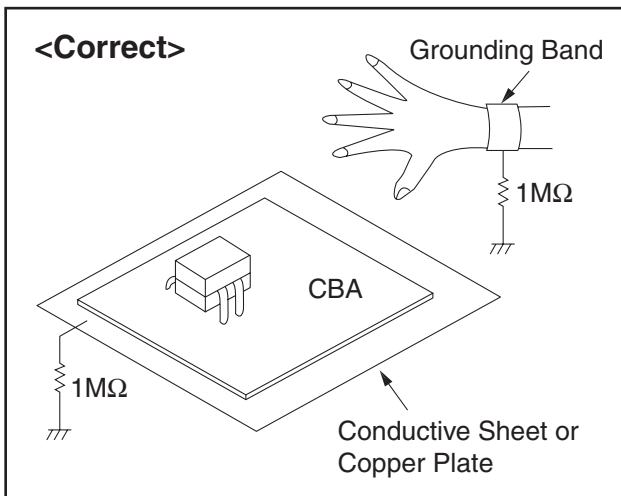
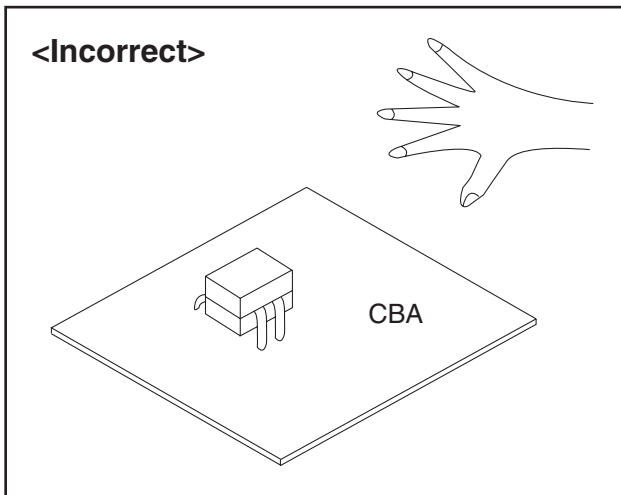

CABINET DISASSEMBLY INSTRUCTIONS

1. Disassembly Flowchart

This flowchart indicates the disassembly steps to gain access to item(s) to be serviced. When reassembling, follow the steps in reverse order. Bend, route, and dress the cables as they were originally.

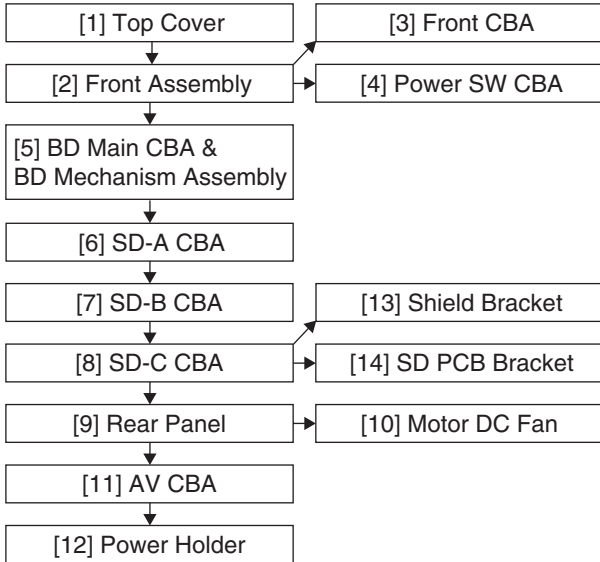

ID/ Loc. No.	Part	Removal		
		Fig. No.	Remove/*Unhook/ Unlock/Release/ Unplug/Desolder	Note
[12]	Power Holder	D5	(S-12)	---
[13]	Shield Bracket	D5	4(S-13)	---
[14]	SD PCB Bracket	D5	(S-14)	---

↓ (1) ↓ (2) ↓ (3) ↓ (4) ↓ (5)

Note:

- (1) Identification (location) No. of parts in the figures
- (2) Name of the part
- (3) Figure Number for reference
- (4) Identification of parts to be removed, unhooked, unlocked, released, unplugged, unclamped, or desoldered.
P = Spring, L = Locking Tab, S = Screw,
CN = Connector
* = Unhook, Unlock, Release, Unplug, or Desolder
e.g. 2(S-2) = two Screws (S-2),
2(L-2) = two Locking Tabs (L-2)
- (5) Refer to "Reference Notes."

2. Disassembly Method

ID/ Loc. No.	Part	Removal		
		Fig. No.	Remove/*Unhook/ Unlock/Release/ Unplug/Desolder	Note
[1]	Top Cover	D1	9(S-1)	---
[2]	Front Assembly	D2	*5(L-1), *3(L-2), *5(S-2) *CN2002, *CN3001	1
[3]	Front CBA	D2	-----	---
[4]	Power SW CBA	D2	-----	---
[5]	BD Main CBA & BD Mechanism Assembly	D3	(S-3), 2(S-4), 4(S-5), 2(S-6), 4(S-7), *CN6001, *CN7101, *CN7601, Main PCB Earth Plate, Front Shield	2
[6]	SD-A CBA	D3	Desolder	---
[7]	SD-B CBA	D3	Desolder	---
[8]	SD-C CBA	D3	-----	---
[9]	Rear Panel	D4	2(S-8), 4(S-9), 2(S-10)	---
[10]	Motor DC Fan	D4	*CN2004, Fan Holder	---
[11]	AV CBA	D5	5(S-11)	---

Reference Notes

- CAUTION 1:** Locking Tabs (L-1) and (L-2) are fragile. Be careful not to break them.
- The BD Main CBA & BD Mechanism Assembly is adjusted as a unit at factory. Therefore, do not disassemble it. Replace the BD Main CBA & BD Mechanism Assembly as a unit.**

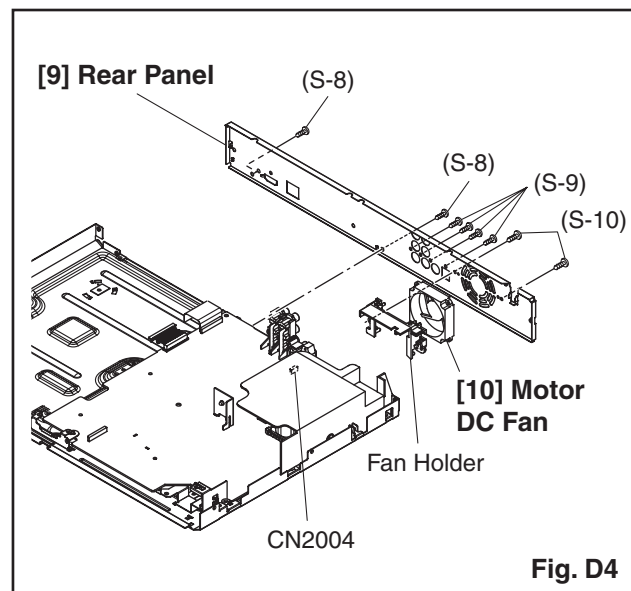
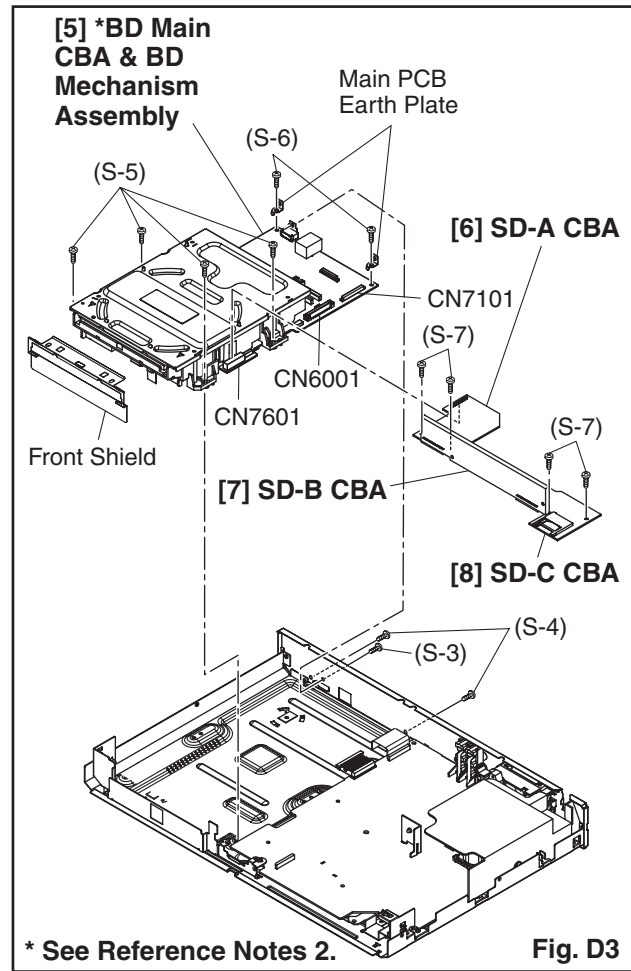
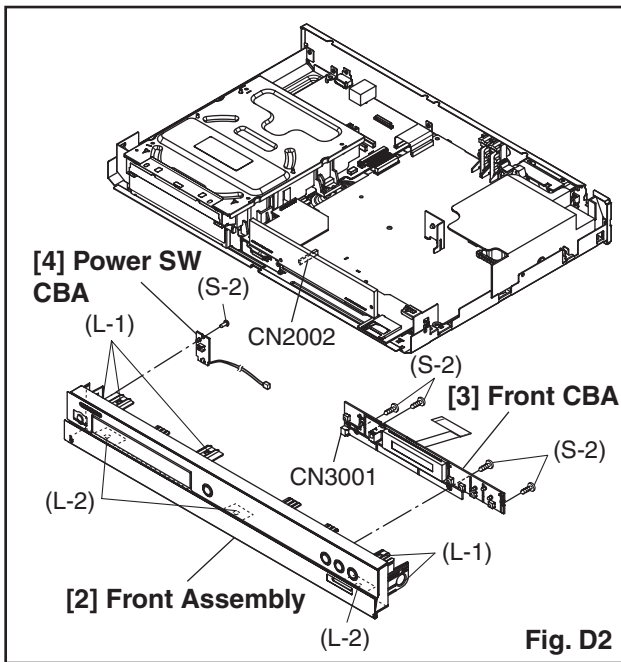
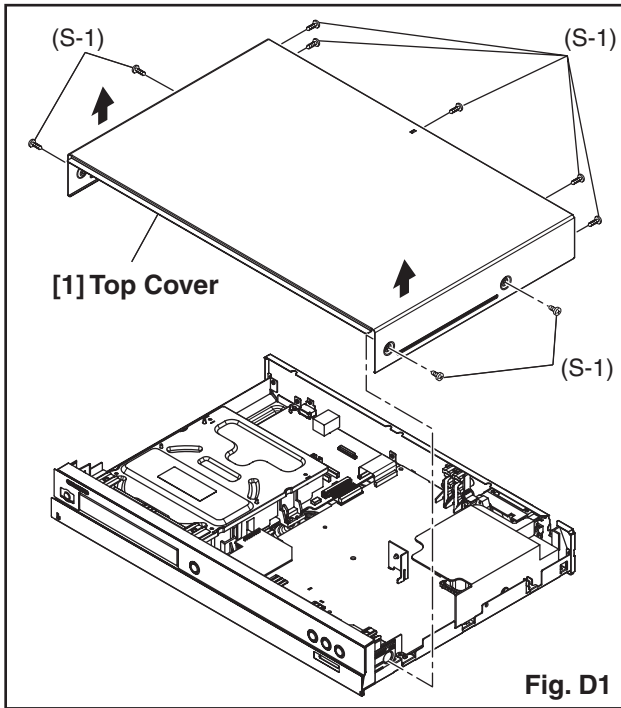

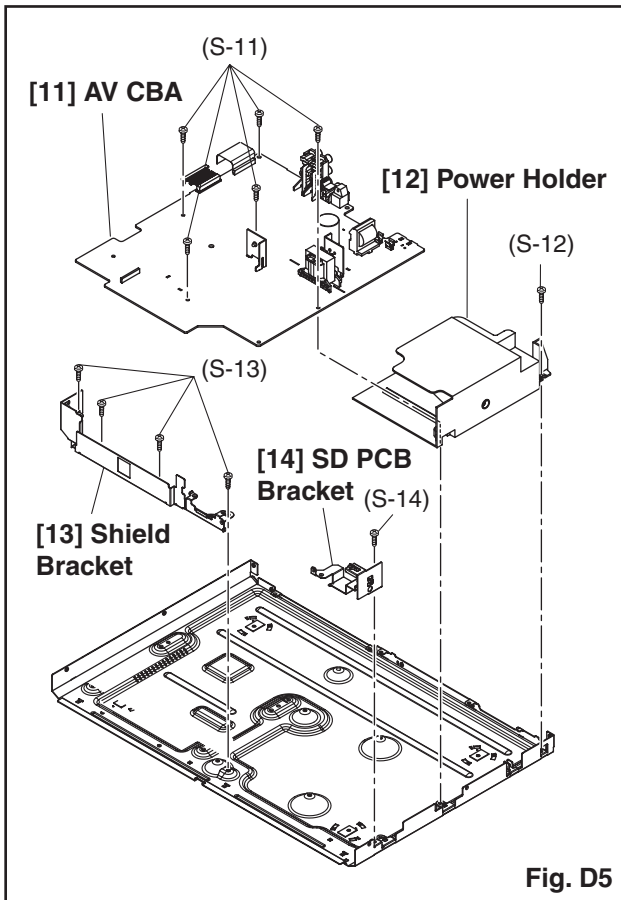
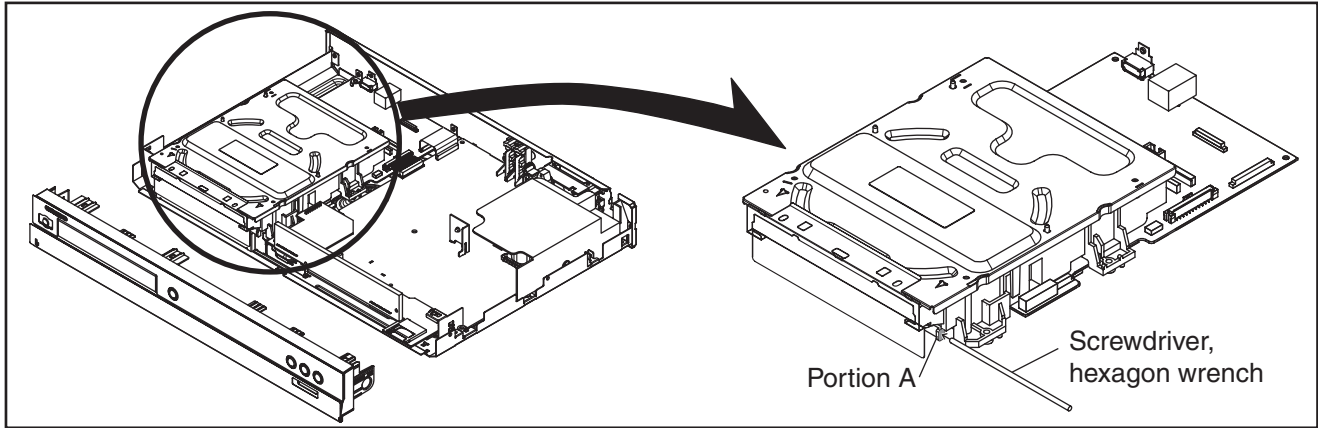

Fig. D5

3. How to Eject Manually

1. Remove the Top Cover.
2. Insert a screwdriver, etc. into the Hole A straightly so that the Portion A is pushed.
3. Pull the tray out manually and remove a disc.



HOW TO INITIALIZE THE BLU-RAY DISC PLAYER

To put the program back at the factory-default, initialize the BD player as the following procedure.

1. Turn the power on.
2. Remove the disc on the tray and close the tray.
3. Press [1], [2], [3], [4], and [DISPLAY] buttons on the remote control unit in that order.

Fig. a appears on the screen.

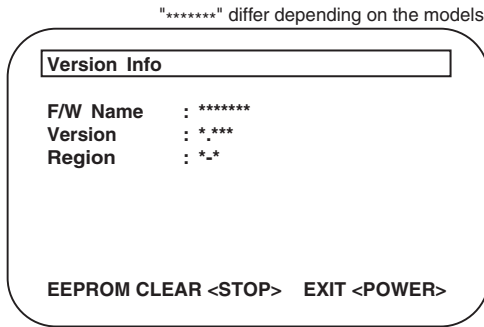

Fig. a

4. Press [■] button on the remote control unit.
Fig. b appears on the screen and Fig. c appears on the VFD.

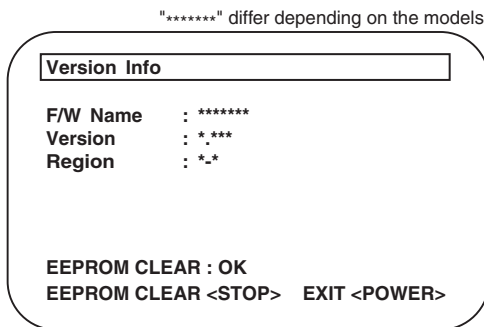

Fig. b

CLEAR

Fig. c

5. To exit this mode, press [ON/STANDBY] button.

FIRMWARE RENEWAL MODE

Note: The file extension of the available firmware is "b20".

1. Turn the power on and remove the disc on the tray and close the tray.
2. To put the BD player into version up mode, press [9], [8], [7], [6], and [POP UP MENU/MENU] buttons on the remote control unit in that order. The tray will open automatically. Fig. a appears on the screen and Fig. b appears on the VFD.

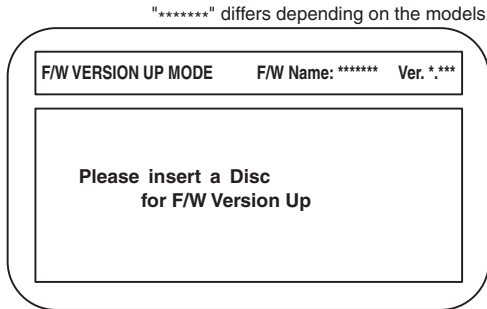

Fig. a Version Up Mode Screen

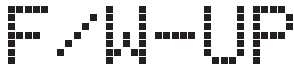

Fig. b VFD in Version Up Mode

3. Load the disc for version up.
4. The BD player enters the F/W version up mode automatically. Fig. c appears on the screen and Fig. d appears on the VFD. Make sure to insert the proper F/W for the state of this model.

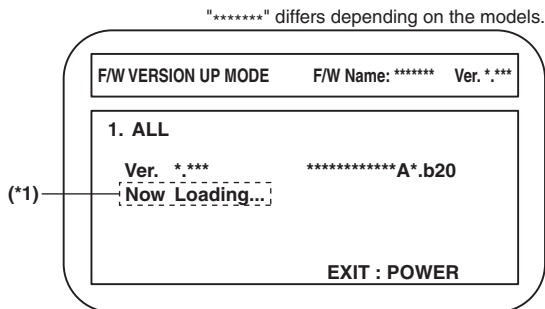

Fig. c Programming Mode Screen (Example)



Fig. d VFD in Programming Mode (Example)

The appearance shown in (*1) of Fig. c is described as follows:

No.	Appearance	State
1	Now Loading...	Loading the disc
2	Reading...	Sending files into the memory. After reading, automatically the tray opens.
3	See FL Display	Writing new version data, the progress will be displayed as shown in Fig. e.



Fig. e VFD in Vresion Up Mode

5. After programming is finished, the checksum on the VFD (Fig. f).



Fig. f VFD upon Finishing the Programming Mode (Example)

Checksum appears on the VFD then the tray will open automatically. Remove the disc on the tray. At this time, no button is available.

6. Unplug the AC cord from the AC outlet. Then plug it again.
7. Turn the power on.
8. Press [1], [2], [3], [4], and [DISPLAY] buttons on the remote control unit in that order. Fig. g appears on the screen.

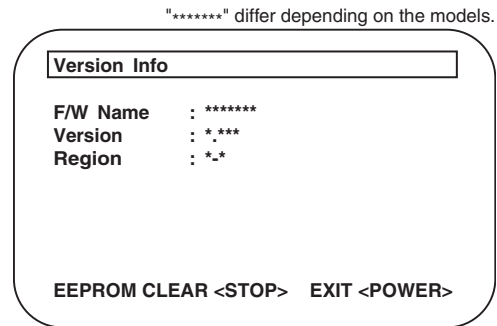

Fig. g

9. Press [■] button on the remote control unit. Fig. h appears on the screen and Fig. i appears on the VFD.

"*****" differ depending on the models.

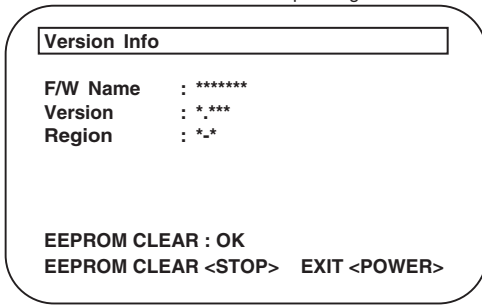

Fig. h

CLEAR

Fig. i

10. To exit this mode, press [ON/STANDBY] button.

How to Verify the Firmware Version

1. Turn the power on.
2. Remove the disc on the tray and close the tray.
3. Press [1], [2], [3], [4], and [DISPLAY] buttons on the remote control unit in that order.

Fig. j appears on the screen.

"*****" differ depending on the models.

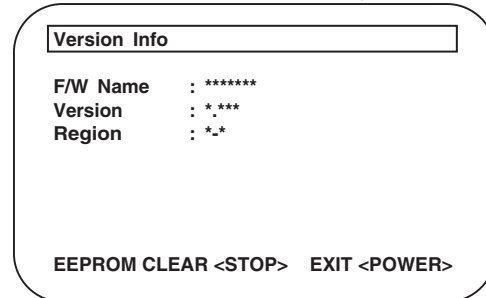
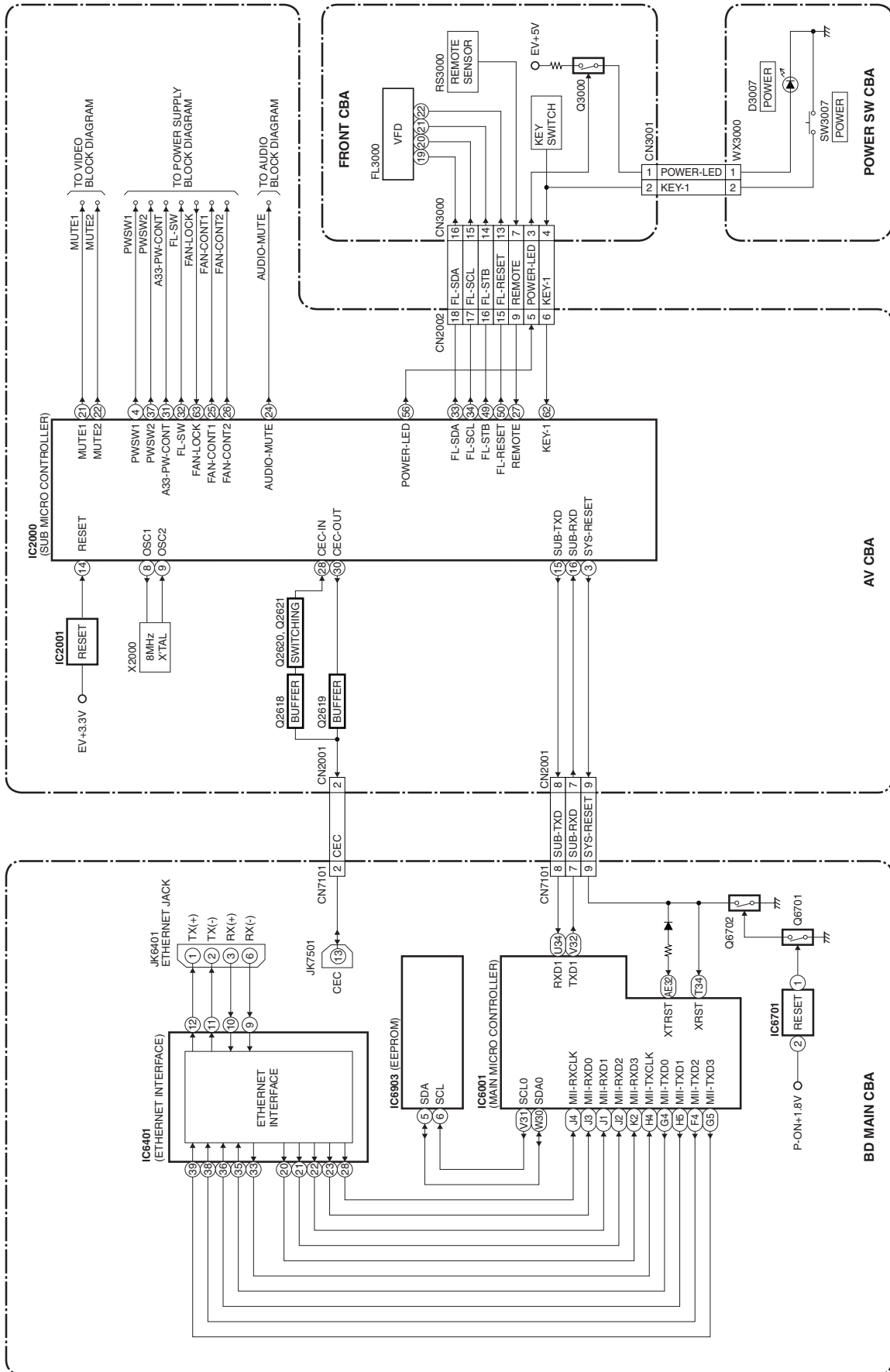

Fig. j

4. To exit this mode, press [ON/STANDBY] button.

BLOCK DIAGRAMS

System Control Block Diagram



Digital Signal Process 1 Block Diagram

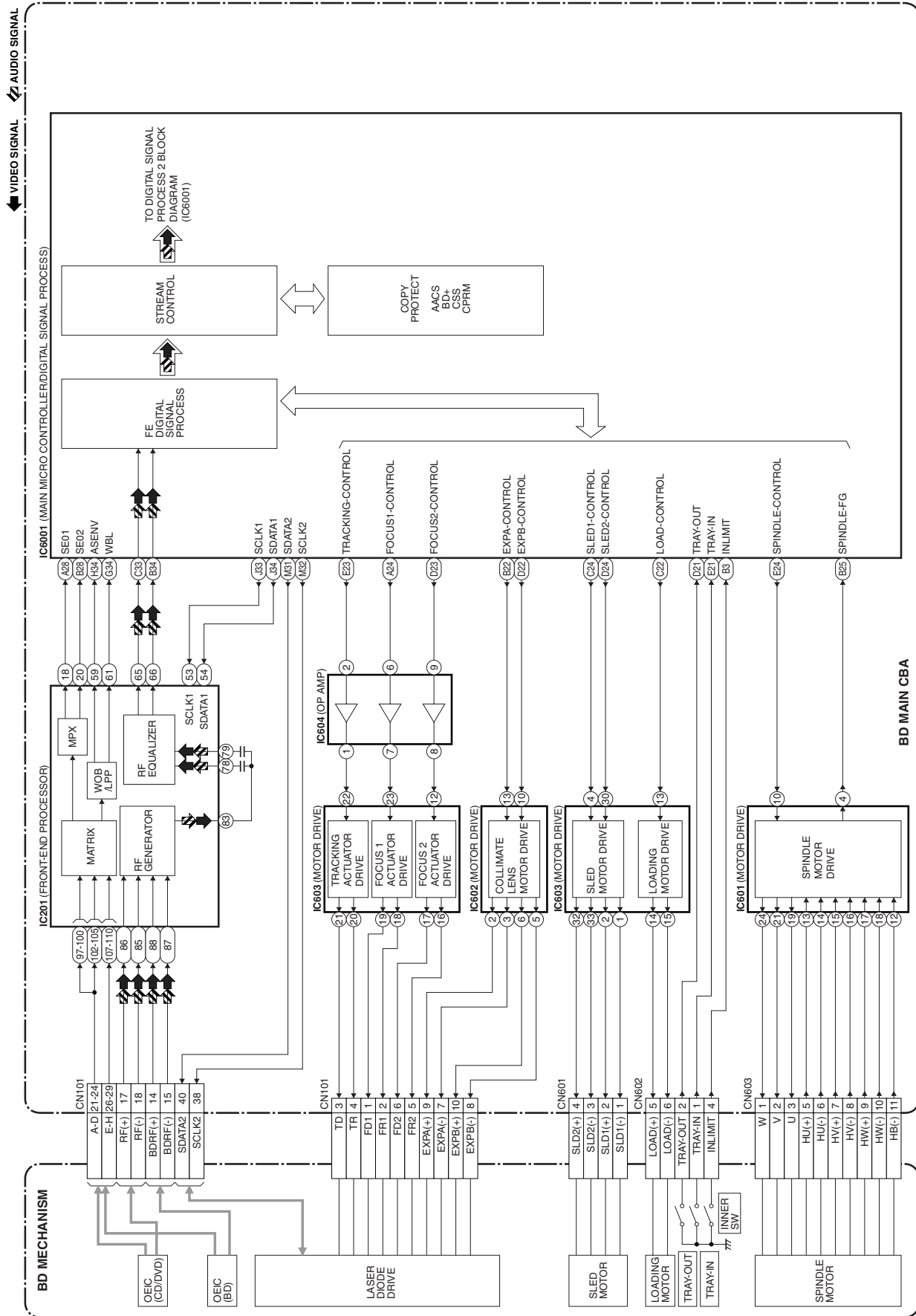

Digital Signal Process 2 Block Diagram

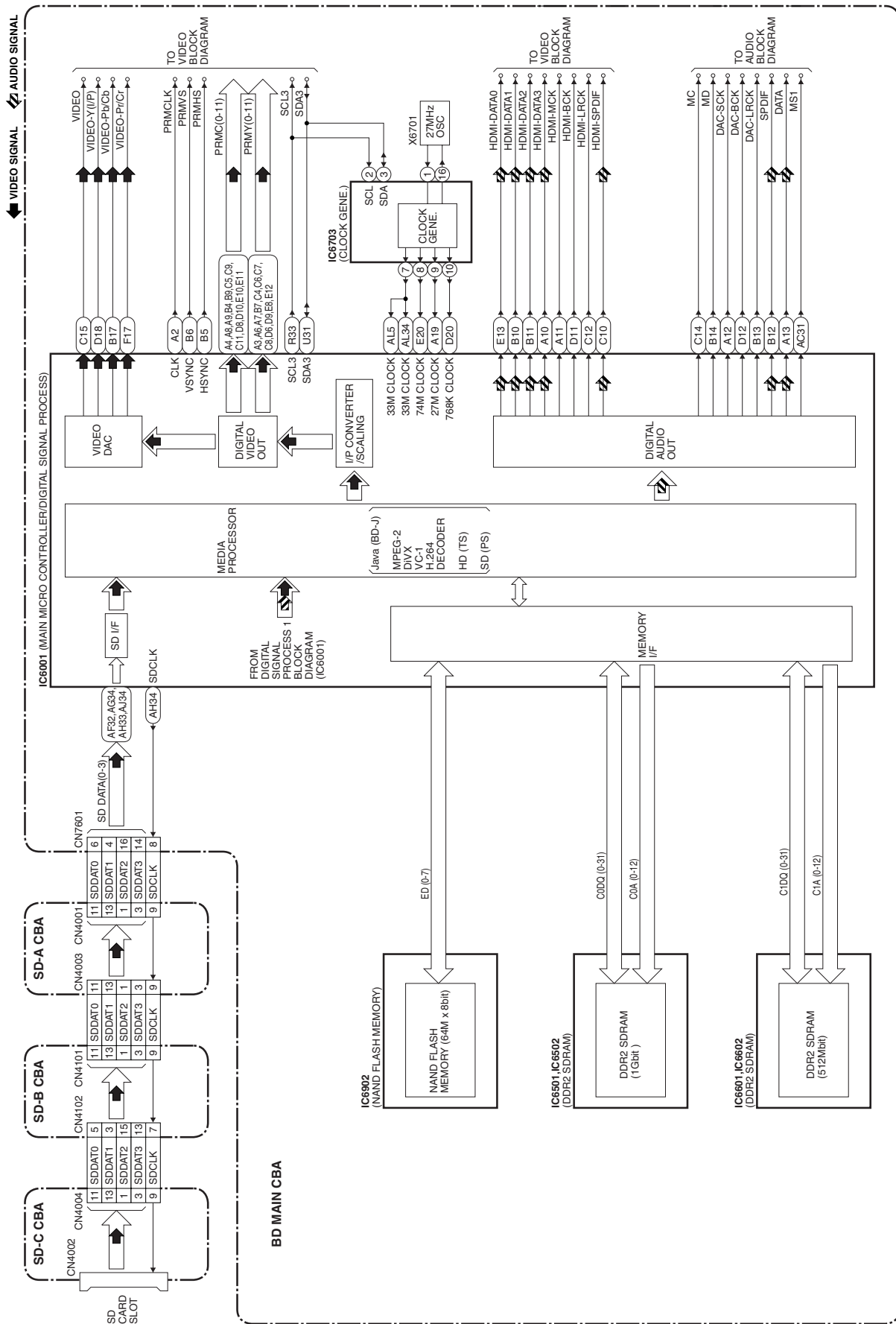

Video Block Diagram

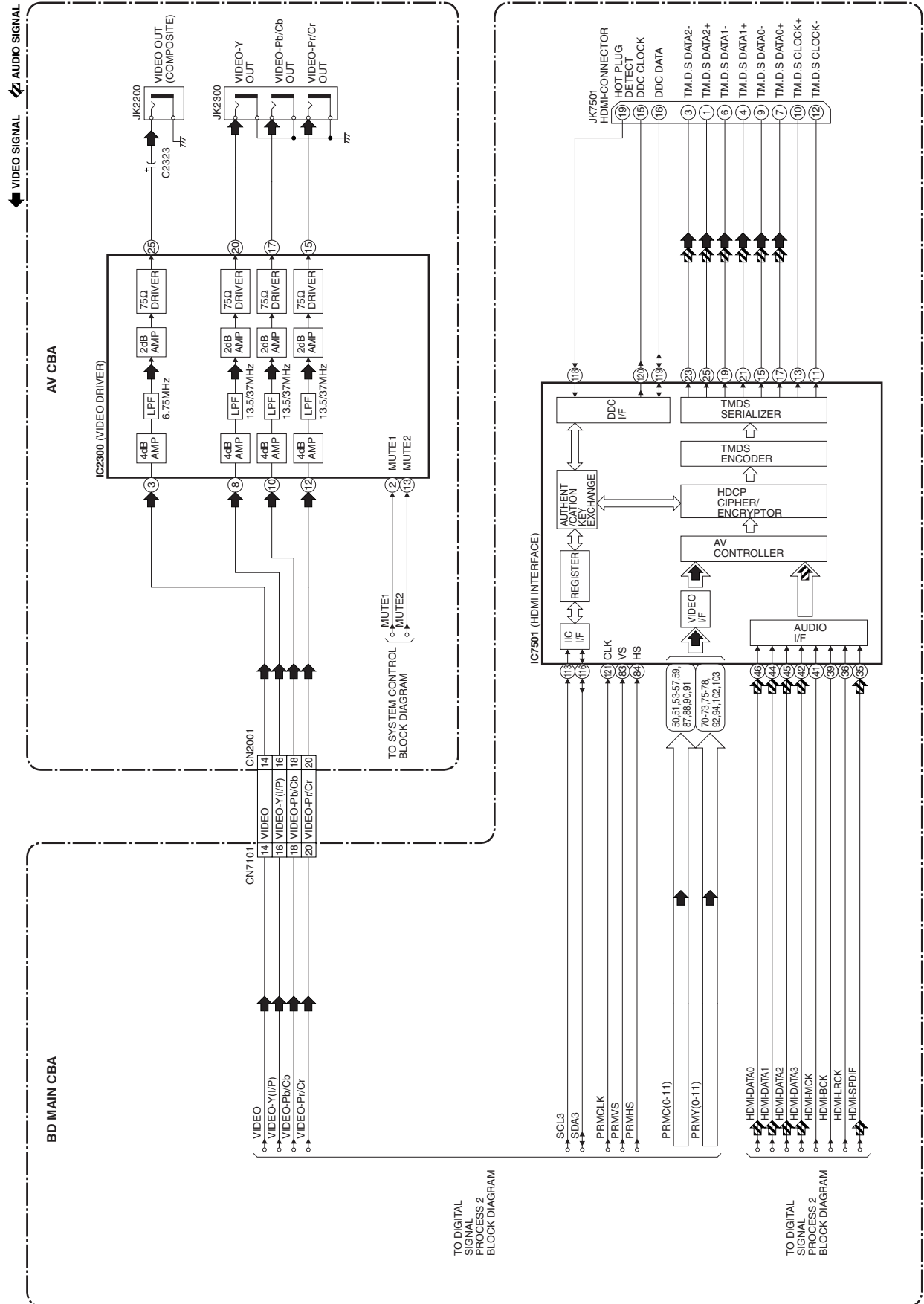

Audio Block Diagram

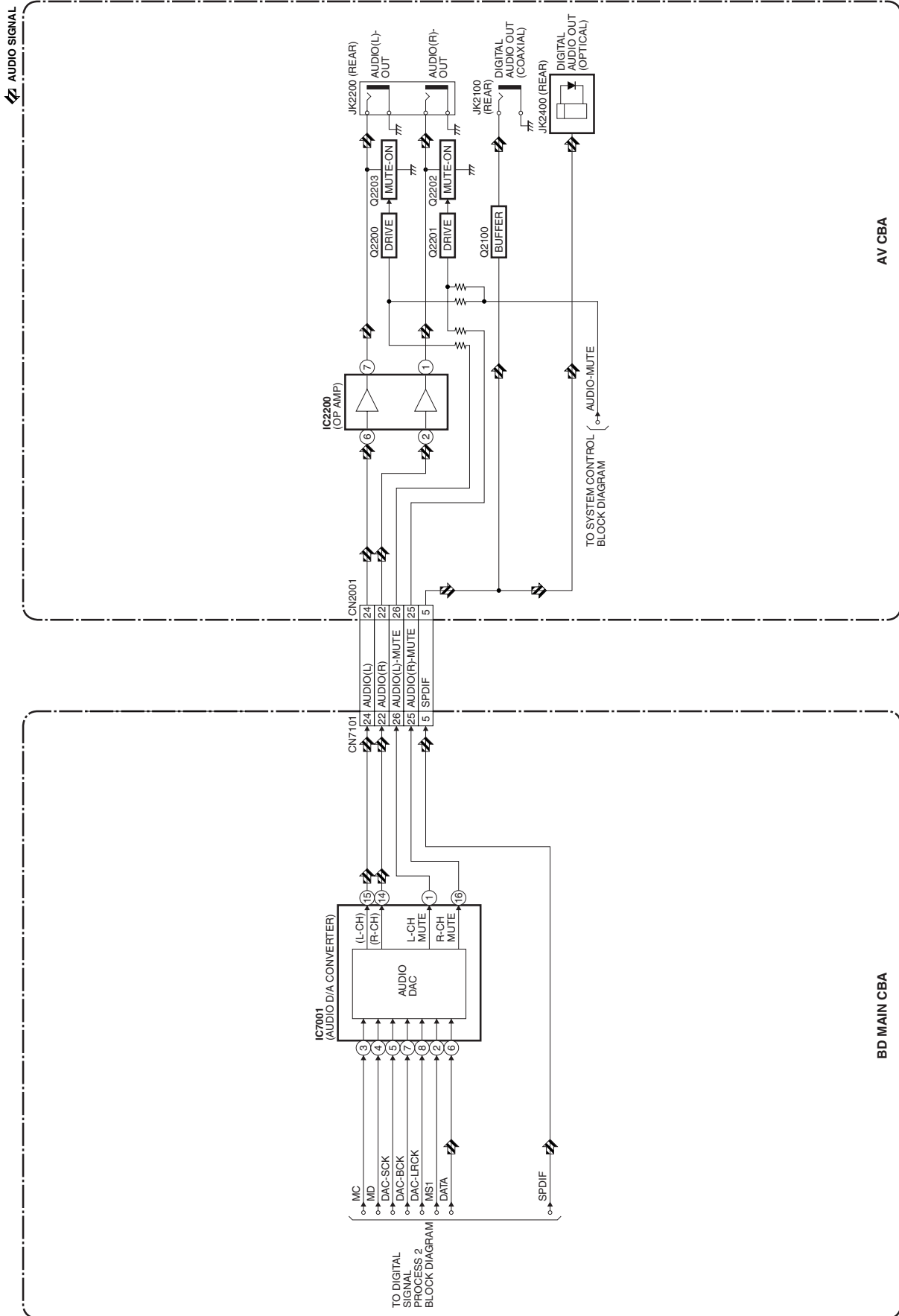

Power Supply Block Diagram

CAUTION !

Fixed voltage (or Auto voltage selectable) power supply circuit is used in this unit.
If Main Fuse (F1001) is blown, check to see that all components in the power supply circuit are not defective before you connect the AC plug to the AC power supply. Otherwise it may cause some components in the power supply circuit to fail.

CAUTION !

For continued protection against fire hazard, replace only with the same type fuse.
ATTENTION : Pour une protection continue les risques d'incendie n'utiliser que des fusibles de même type.
Risk of fire-replace fuse as marked.

"This symbol means fast operating fuse."
"Ce symbole représente un fusible à fusion rapide."

NOTE:

The voltage for parts in hot circuit is measured using hot GND as a common terminal.

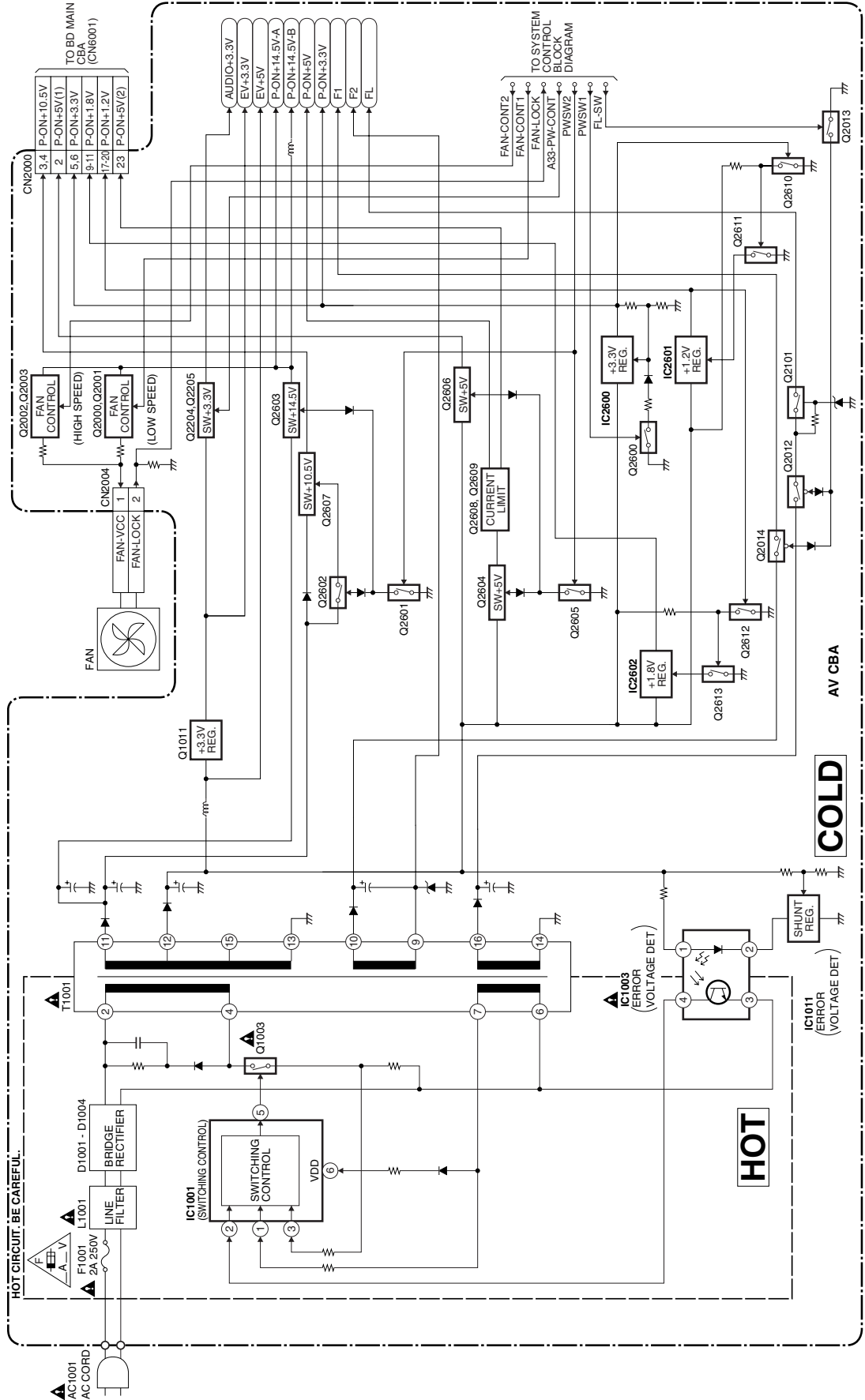

SCHEMATIC DIAGRAMS / CBA AND TEST POINTS

Standard Notes

WARNING

Many electrical and mechanical parts in this chassis have special characteristics. These characteristics often pass unnoticed and the protection afforded by them cannot necessarily be obtained by using replacement components rated for higher voltage, wattage, etc. Replacement parts that have these special safety characteristics are identified in this manual and its supplements; electrical components having such features are identified by the mark “▲” in the schematic diagram and the parts list. Before replacing any of these components, read the parts list in this manual carefully. The use of substitute replacement parts that do not have the same safety characteristics as specified in the parts list may create shock, fire, or other hazards.

Notes:

1. Do not use the part number shown on these drawings for ordering. The correct part number is shown in the parts list, and may be slightly different or amended since these drawings were prepared.
2. All resistance values are indicated in ohms (K = 10^3 , M = 10^6).
3. Resistor wattages are 1/4W or 1/6W unless otherwise specified.
4. All capacitance values are indicated in μF (P = 10^{-6} μF).
5. All voltages are DC voltages unless otherwise specified.

LIST OF CAUTION, NOTES, AND SYMBOLS USED IN THE SCHEMATIC DIAGRAMS ON THE FOLLOWING PAGES:

1. CAUTION:

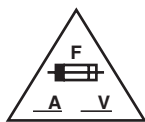

FOR CONTINUED PROTECTION AGAINST FIRE HAZARD, REPLACE ONLY WITH THE SAME TYPE FUSE.
 ATTENTION: POUR UNE PROTECTION CONTINUE LES RISQUES D'INCELE N'UTILISER QUE DES FUSIBLE DE MÊME TYPE.
 RISK OF FIRE-REPLACE FUSE AS MARKED.



This symbol means fast operating fuse.
 Ce symbole représente un fusible à fusion rapide.

2. CAUTION:

Fixed Voltage (or Auto voltage selectable) power supply circuit is used in this unit.
 If Main Fuse (F1001) is blown, first check to see that all components in the power supply circuit are not defective before you connect the AC plug to the AC power supply. Otherwise it may cause some components in the power supply circuit to fail.

3. Note:

- Do not use the part number shown on the drawings for ordering. The correct part number is shown in the parts list, and may be slightly different or amended since the drawings were prepared.
- To maintain original function and reliability of repaired units, use only original replacement parts which are listed with their part numbers in the parts list section of the service manual.

4. Voltage indications for PLAY and STOP mode on the schematics are as shown below:

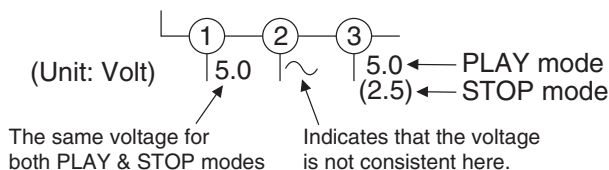

5. How to read converged lines

1-D3
 ↑ Distinction Area
 ↑ Line Number
 (1 to 3 digits)

Examples:

- "1-D3" means that line number "1" goes to the line number "1" of the area "D3".
- "1-B1" means that line number "1" goes to the line number "1" of the area "B1".

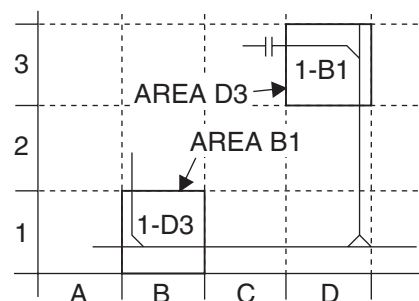

6. Test Point Information

- : Indicates a test point with a jumper wire across a hole in the PCB.
- : Used to indicate a test point with a component lead on foil side.
- : Used to indicate a test point with no test pin.
- : Used to indicate a test point with a test pin.

AV 1/3 Schematic Diagram

CAUTION !

Fixed voltage (or Auto voltage selectable) power supply circuit is used in this unit.
If Main Fuse (F1001) is blown, check to see that all components in the power supply circuit are not defective before you connect the AC plug to the AC power supply.
Otherwise it may cause some components in the power supply circuit to fail.

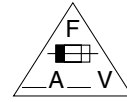

CAUTION !

For continued protection against fire hazard, replace only with the same type fuse.
ATTENTION : Pour une protection continue les risques d'Incele n'utiliser que des fusible de même type.
Risk of fire-replace fuse as marked.
This symbol means fast operating fuse.
"Ce symbole représente un fusible à fusion rapide."

NOTE:

The voltage for parts in hot circuit is measured using hot GND as a common terminal.

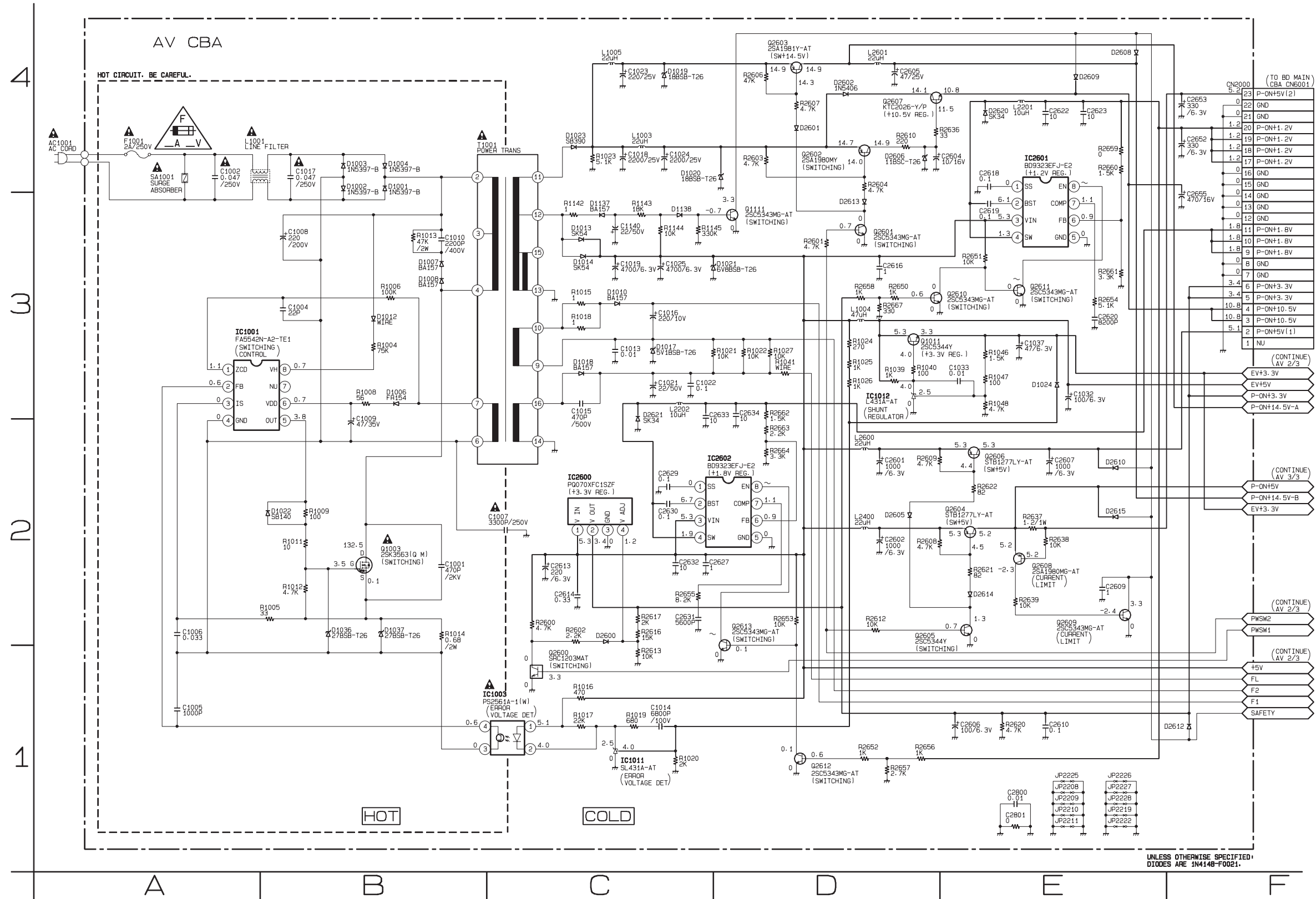

UNLESS OTHERWISE SPECIFIED, DIODES ARE 1N4148-F0021.

AV 2/3 Schematic Diagram

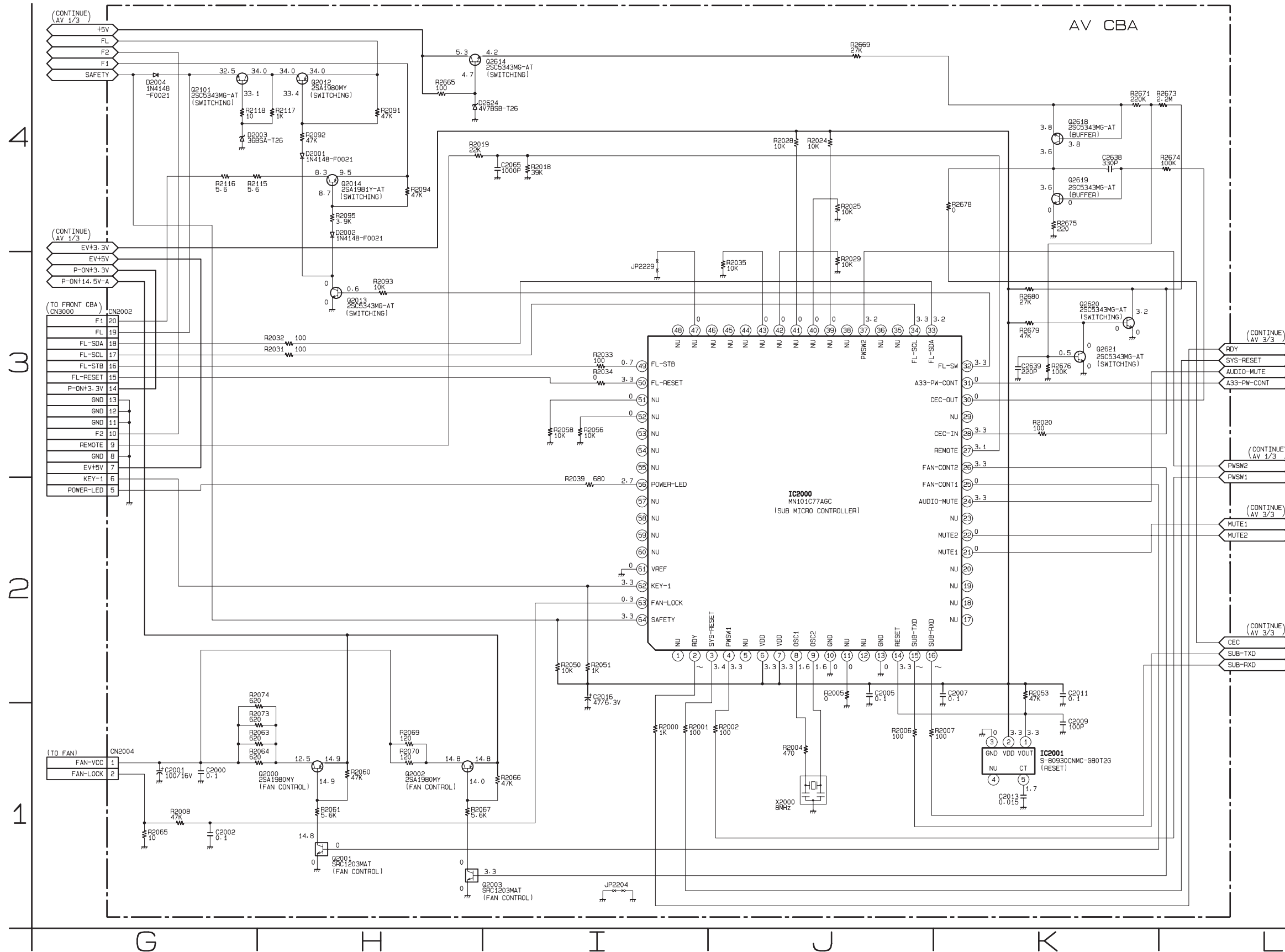

AV 3/3 Schematic Diagram

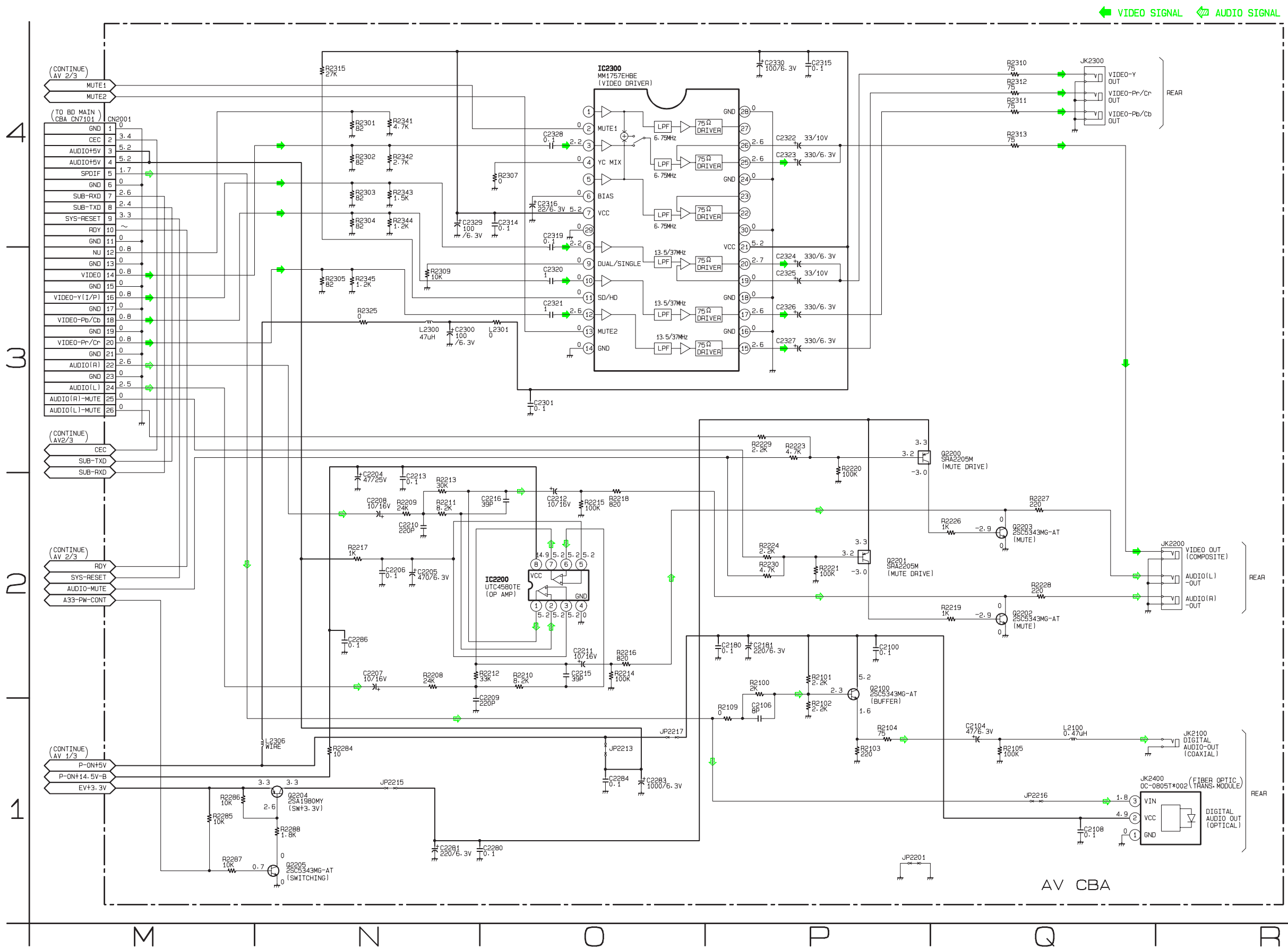

Front & Power SW Schematic Diagram

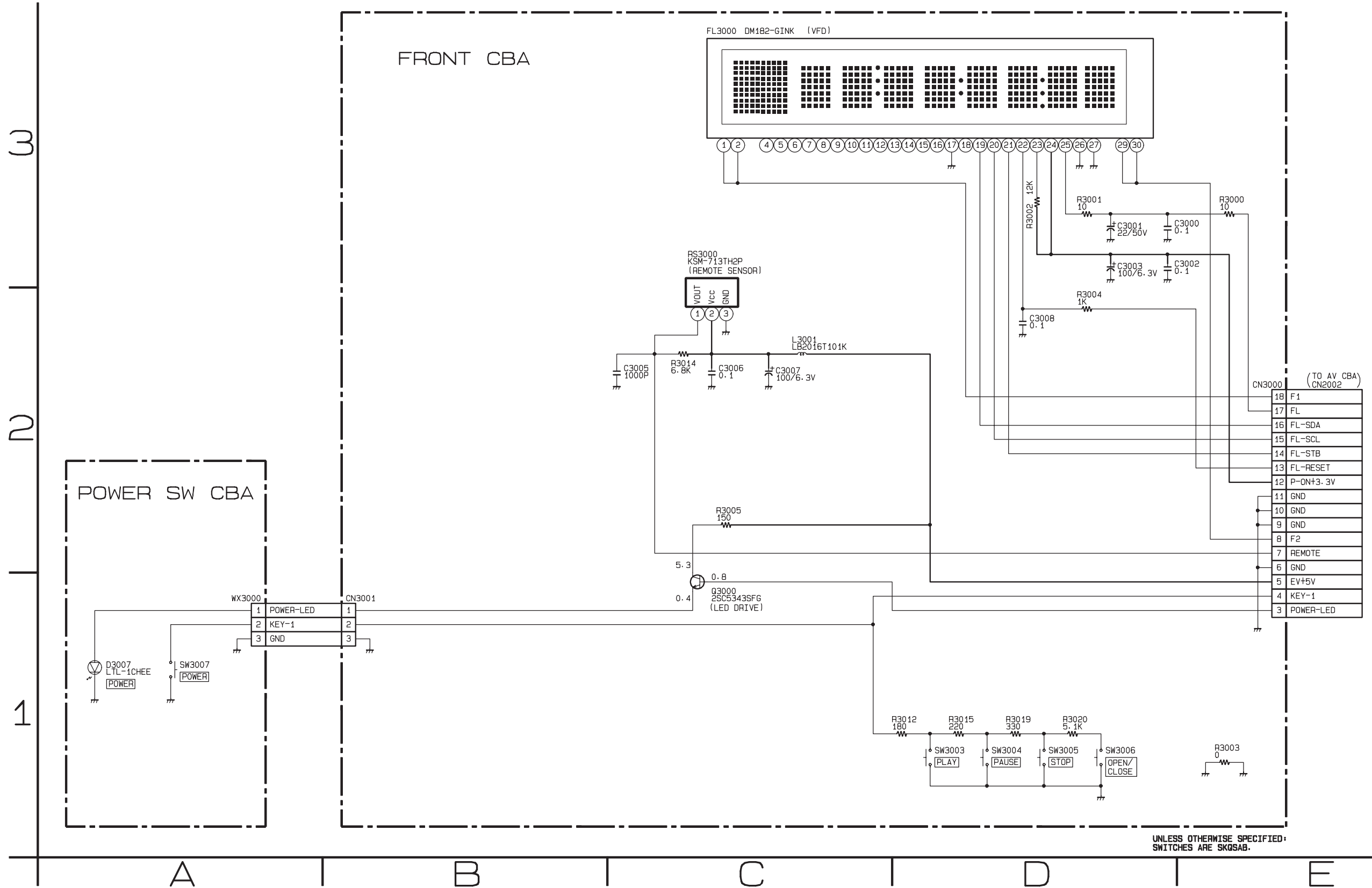

SD-A, SD-B & SD-C Schematic Diagram

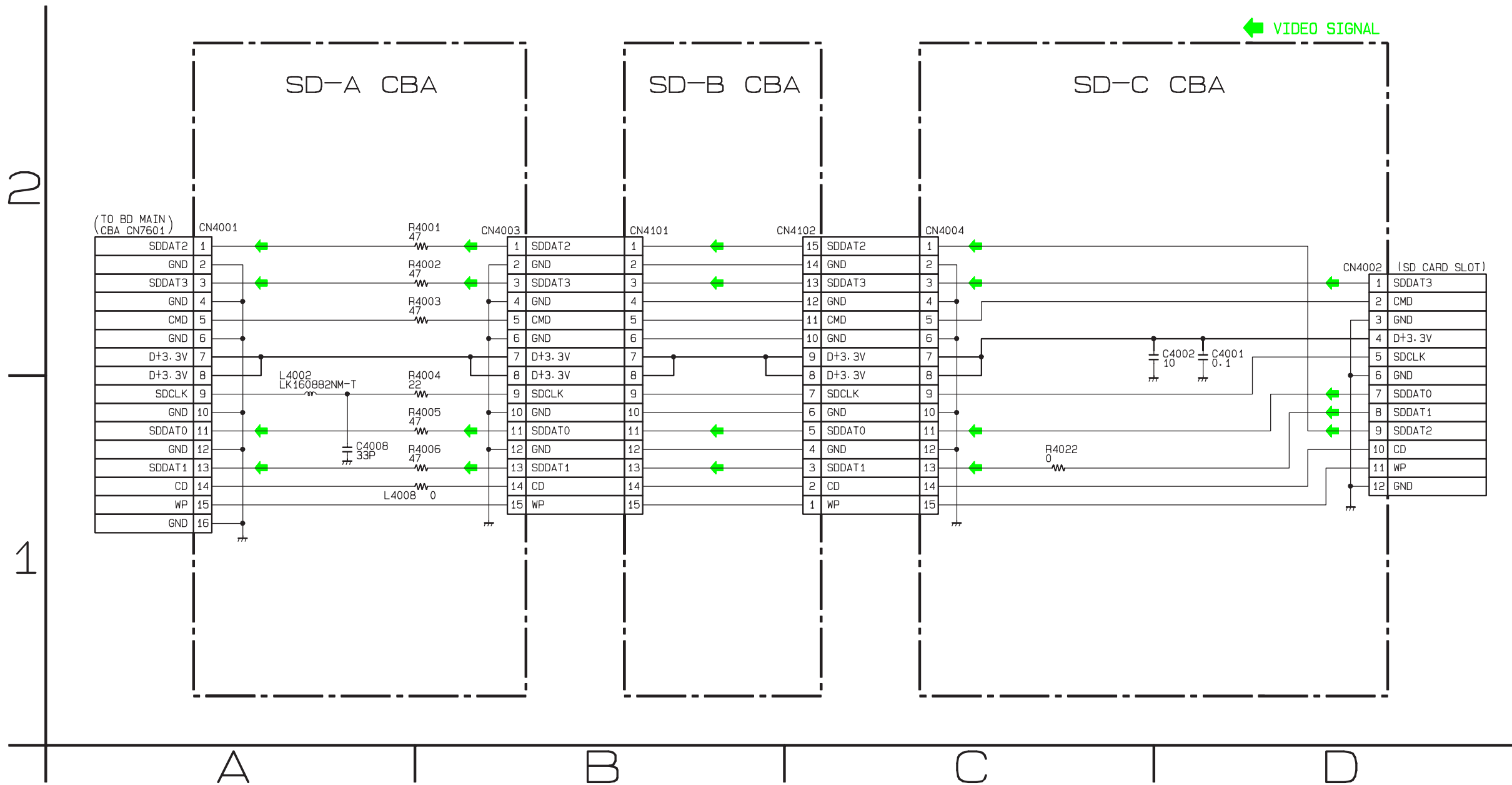

BD Main 1/11 Schematic Diagram

*1 NOTE:

The order of pins shown in this diagram is different from that of actual IC6001.
IC6001 is divided into nine and shown as IC6001 (1/9) ~ IC6001 (9/9) in this BD Main Schematic Diagram Section.

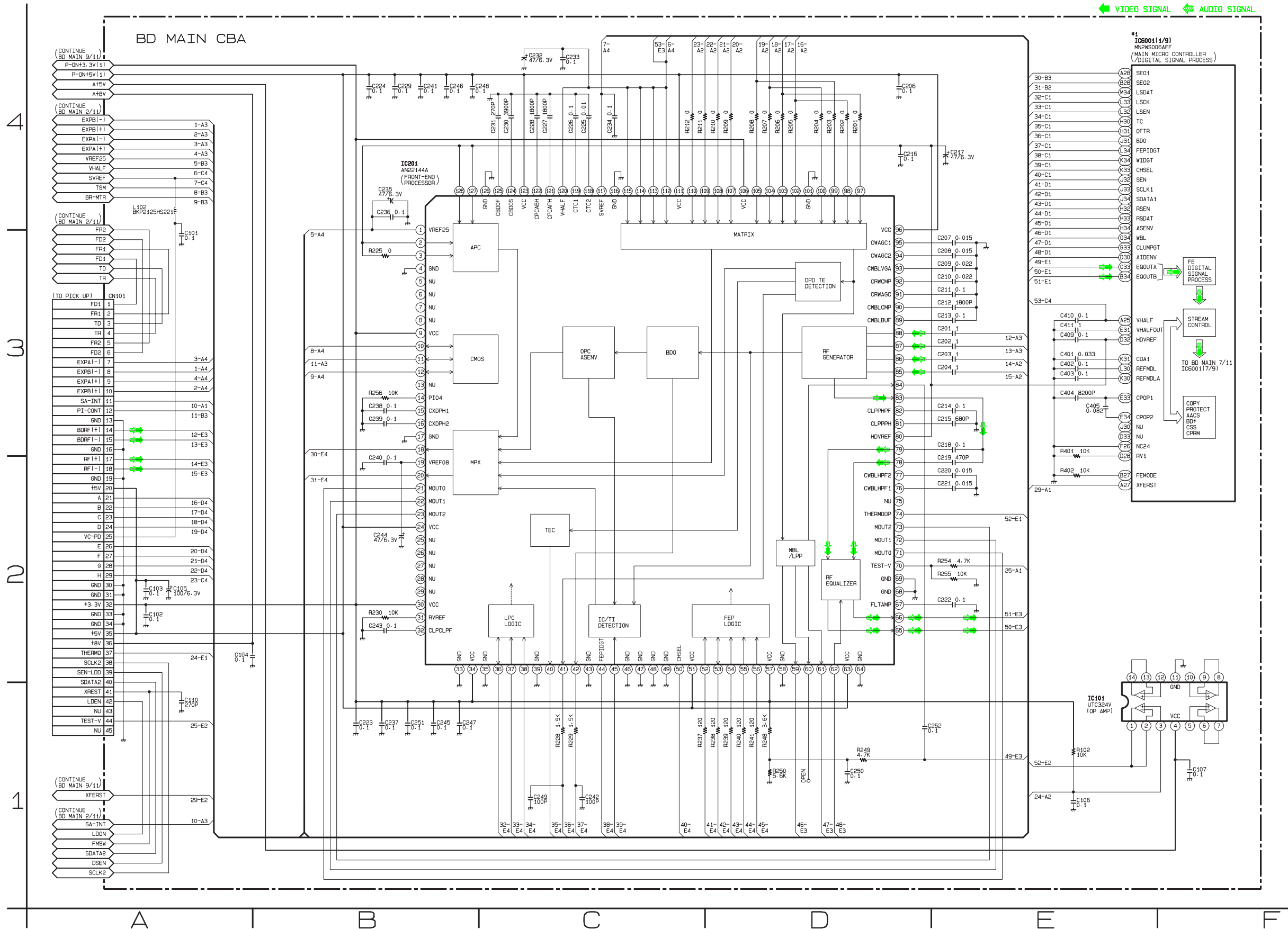

BD Main 2/11 Schematic Diagram

***1 NOTE:**

The order of pins shown in this diagram is different from that of actual IC6001.
 IC6001 is divided into nine and shown as IC6001 (1/9) ~ IC6001 (9/9) in this BD Main Schematic Diagram Section.

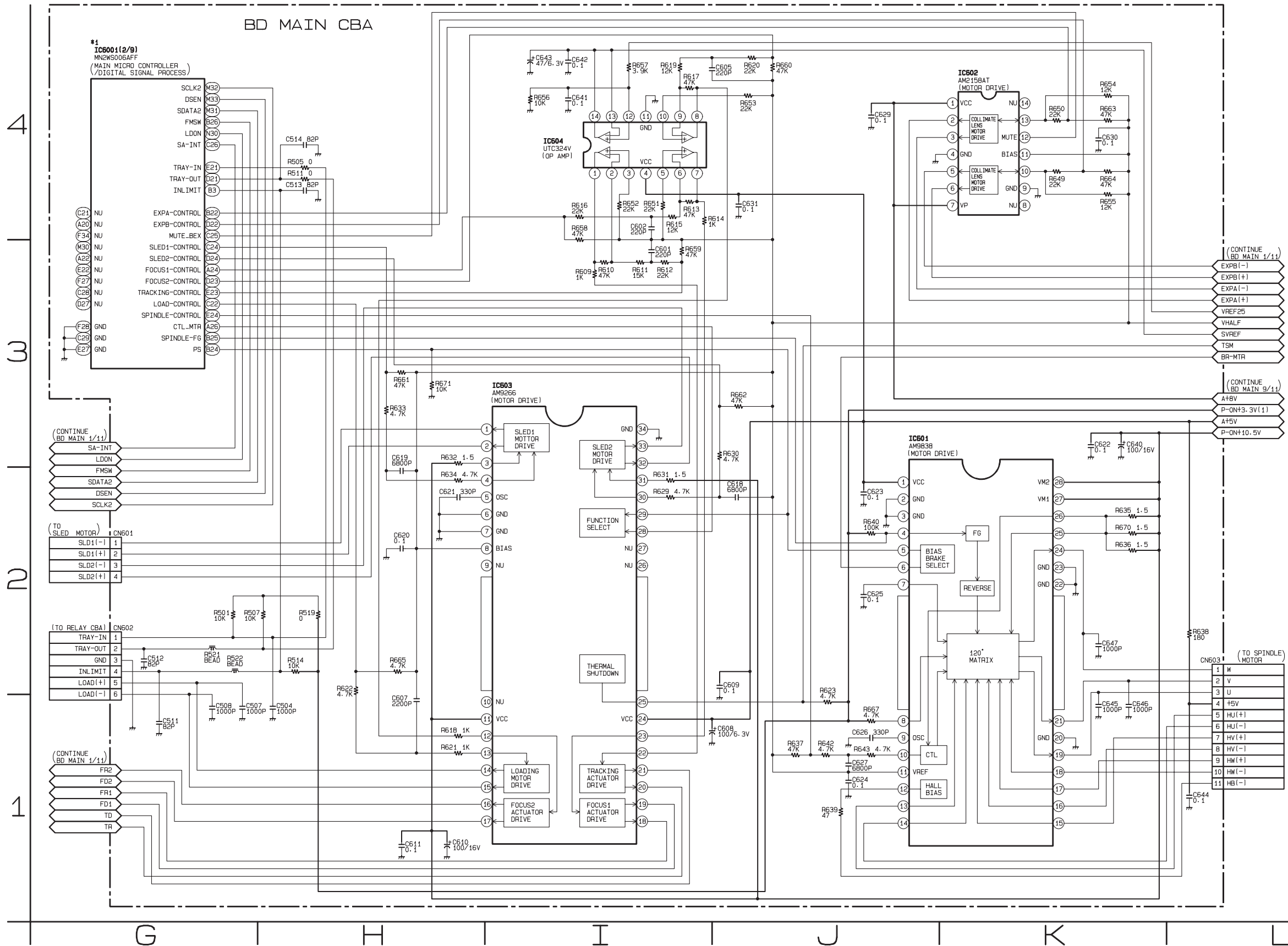

BD Main 3/11 Schematic Diagram

***1 NOTE:**

The order of pins shown in this diagram is different from that of actual IC6001.
 IC6001 is divided into nine and shown as IC6001 (1/9) ~ IC6001 (9/9) in this BD Main Schematic Diagram Section.

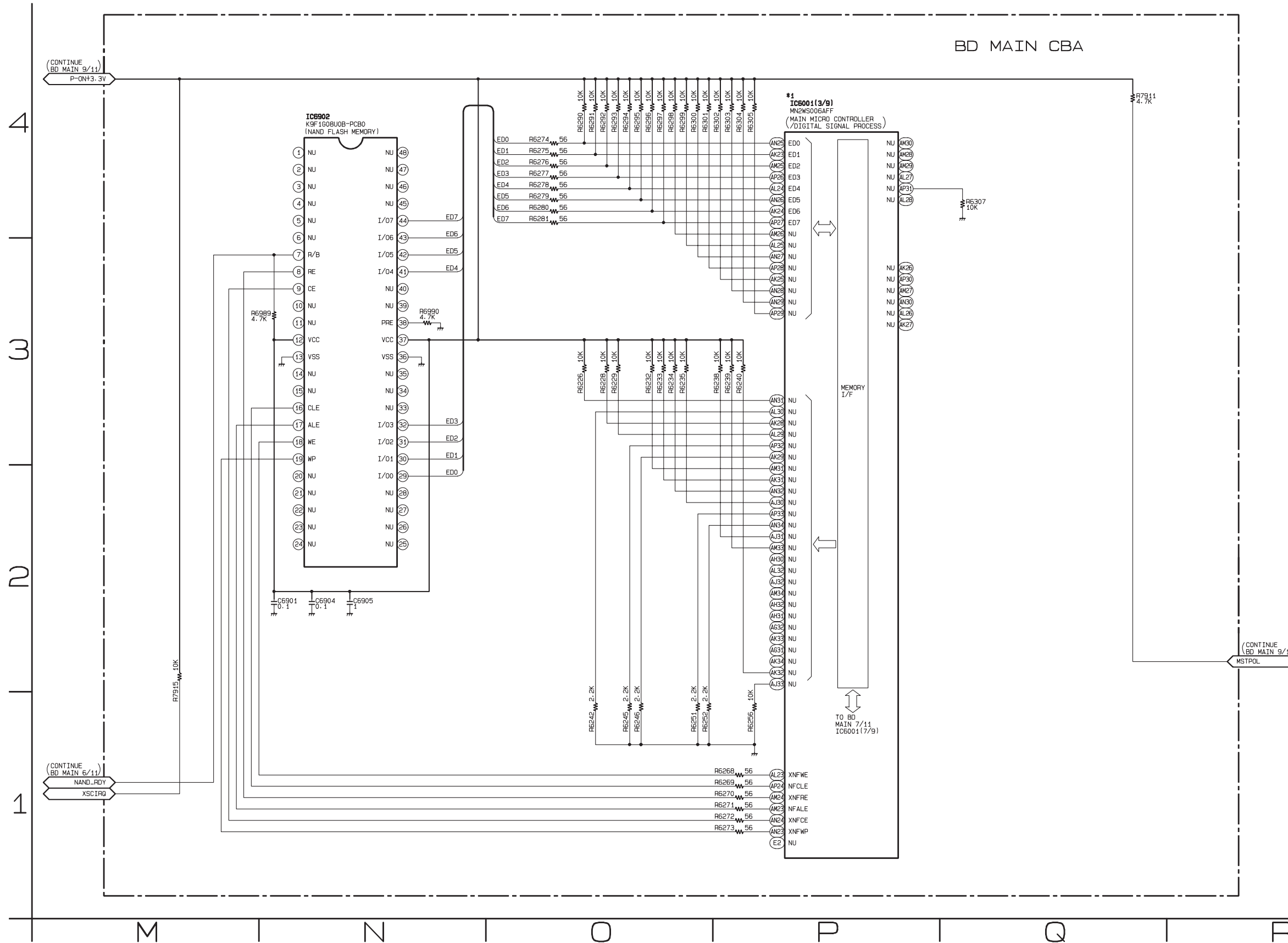

BD Main 4/11 Schematic Diagram

*1 NOTE:

The order of pins shown in this diagram is different from that of actual IC6001.
IC6001 is divided into nine and shown as IC6001 (1/9) ~ IC6001 (9/9) in this BD Main Schematic Diagram Section.

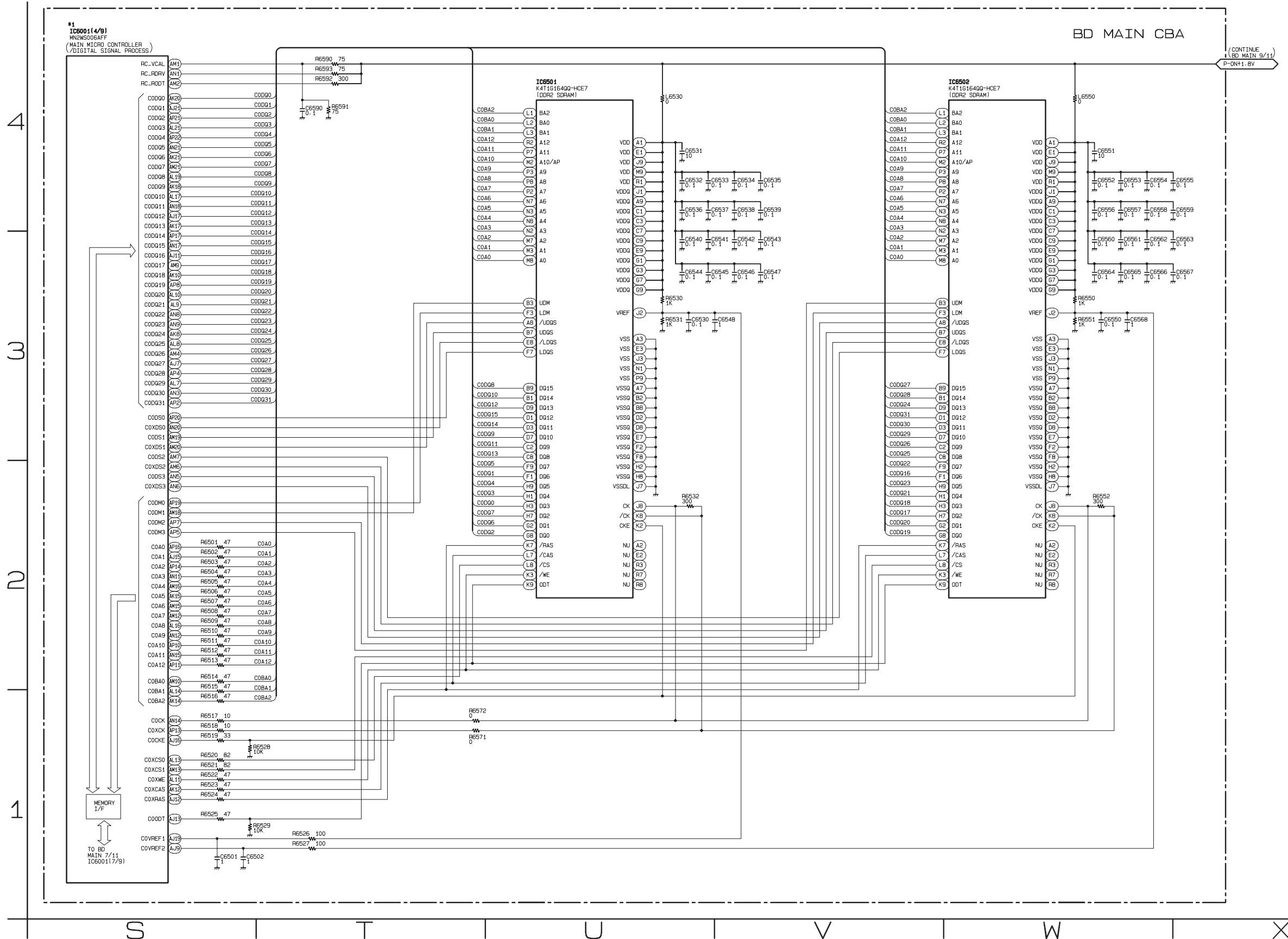

(CONTINUE)
BD MAIN 9/11
P-OH1: 8V

BD Main 5/11 Schematic Diagram

*1 NOTE:

The order of pins shown in this diagram is different from that of actual IC6001.
IC6001 is divided into nine and shown as IC6001 (1/9) ~ IC6001 (9/9) in this BD Main Schematic Diagram Section.

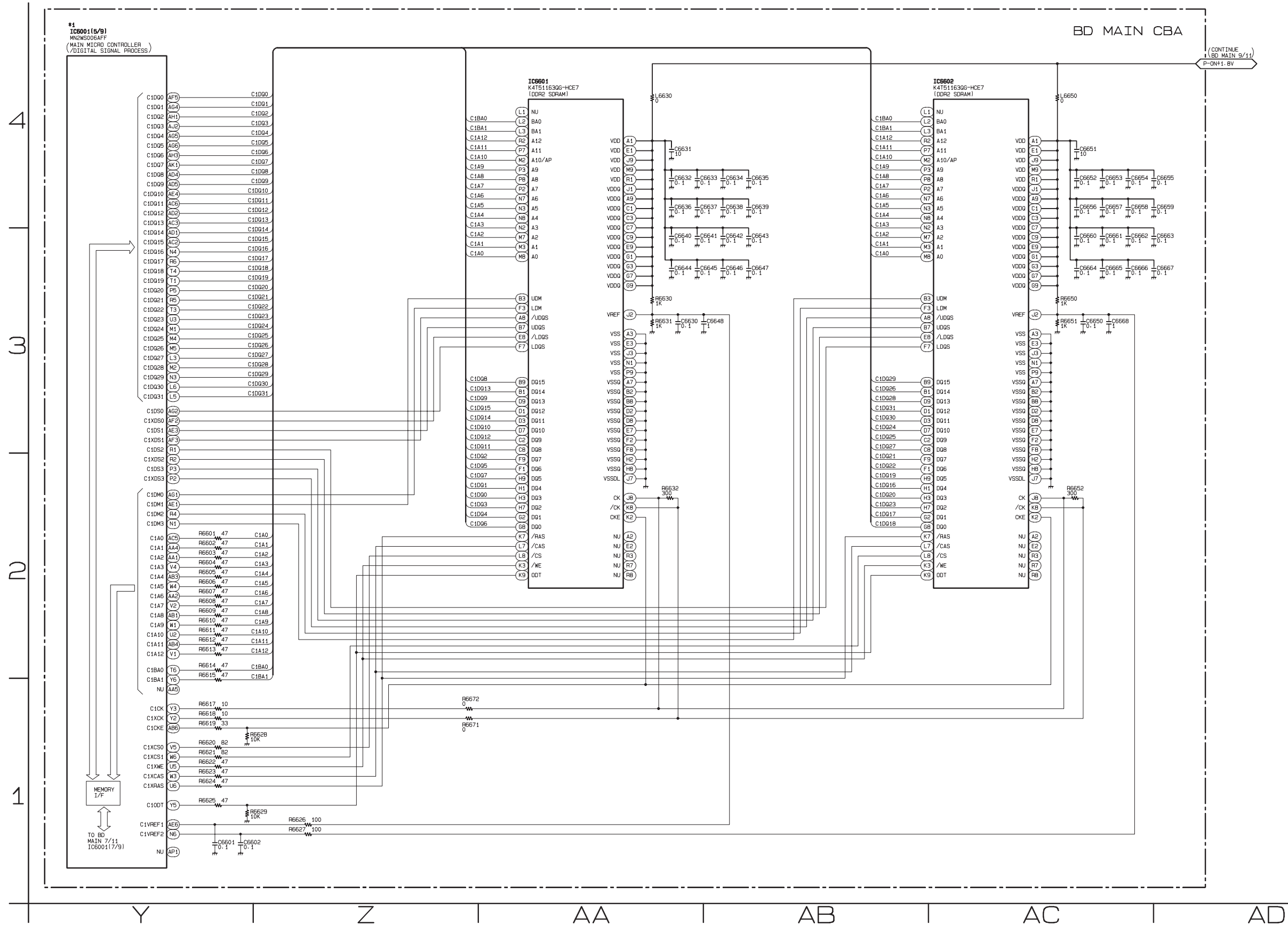

(CONTINUE)
BD MAIN 9/11
P-0H1: BV

BD Main 6/11 Schematic Diagram

***1 NOTE:**

The order of pins shown in this diagram is different from that of actual IC6001.
 IC6001 is divided into nine and shown as IC6001 (1/9) ~ IC6001 (9/9) in this BD Main Schematic Diagram Section.

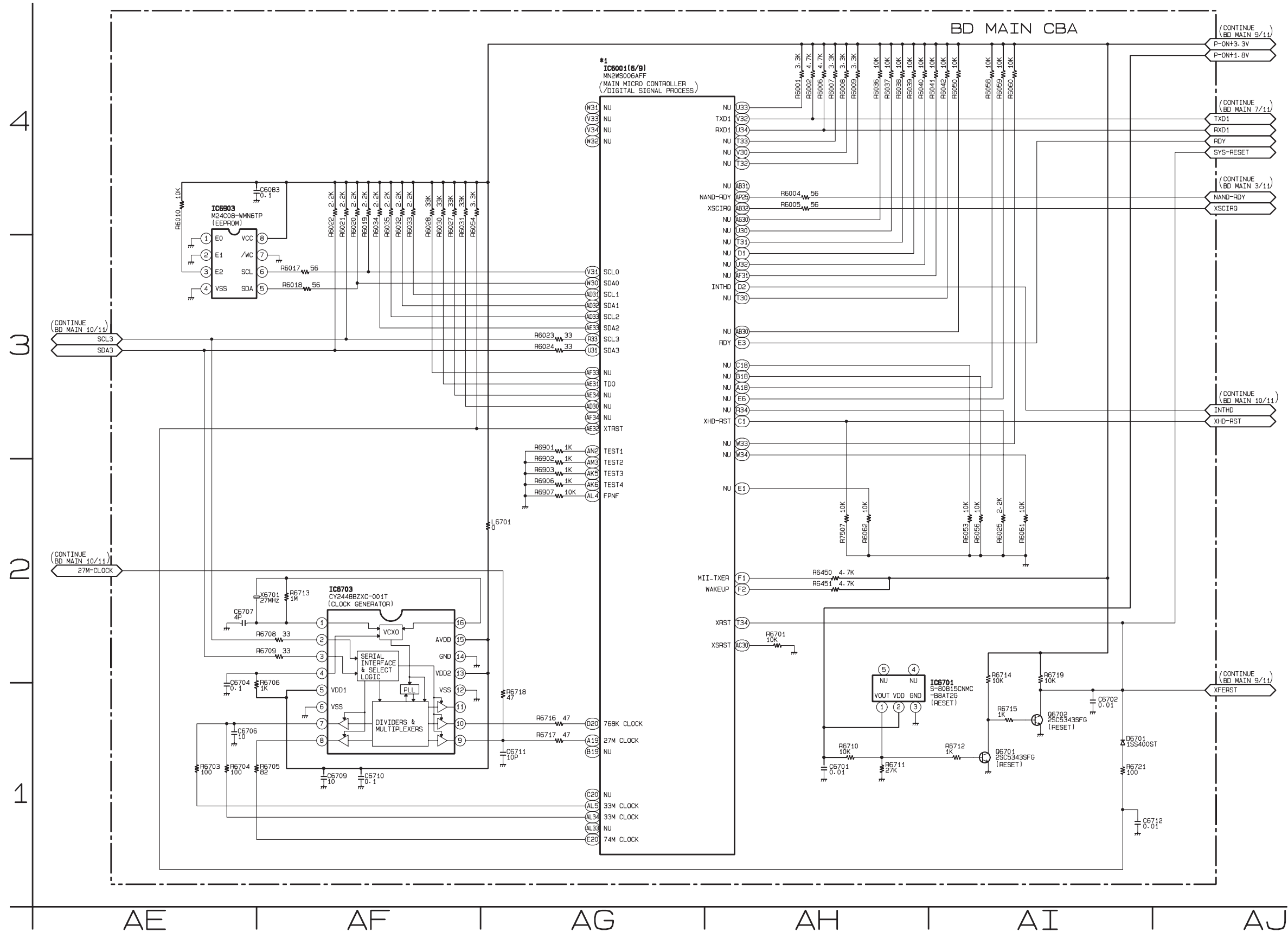

BD Main 7/11 Schematic Diagram

***1 NOTE:**

The order of pins shown in this diagram is different from that of actual IC6001.
 IC6001 is divided into nine and shown as IC6001 (1/9) ~ IC6001 (9/9) in this BD Main Schematic Diagram Section.

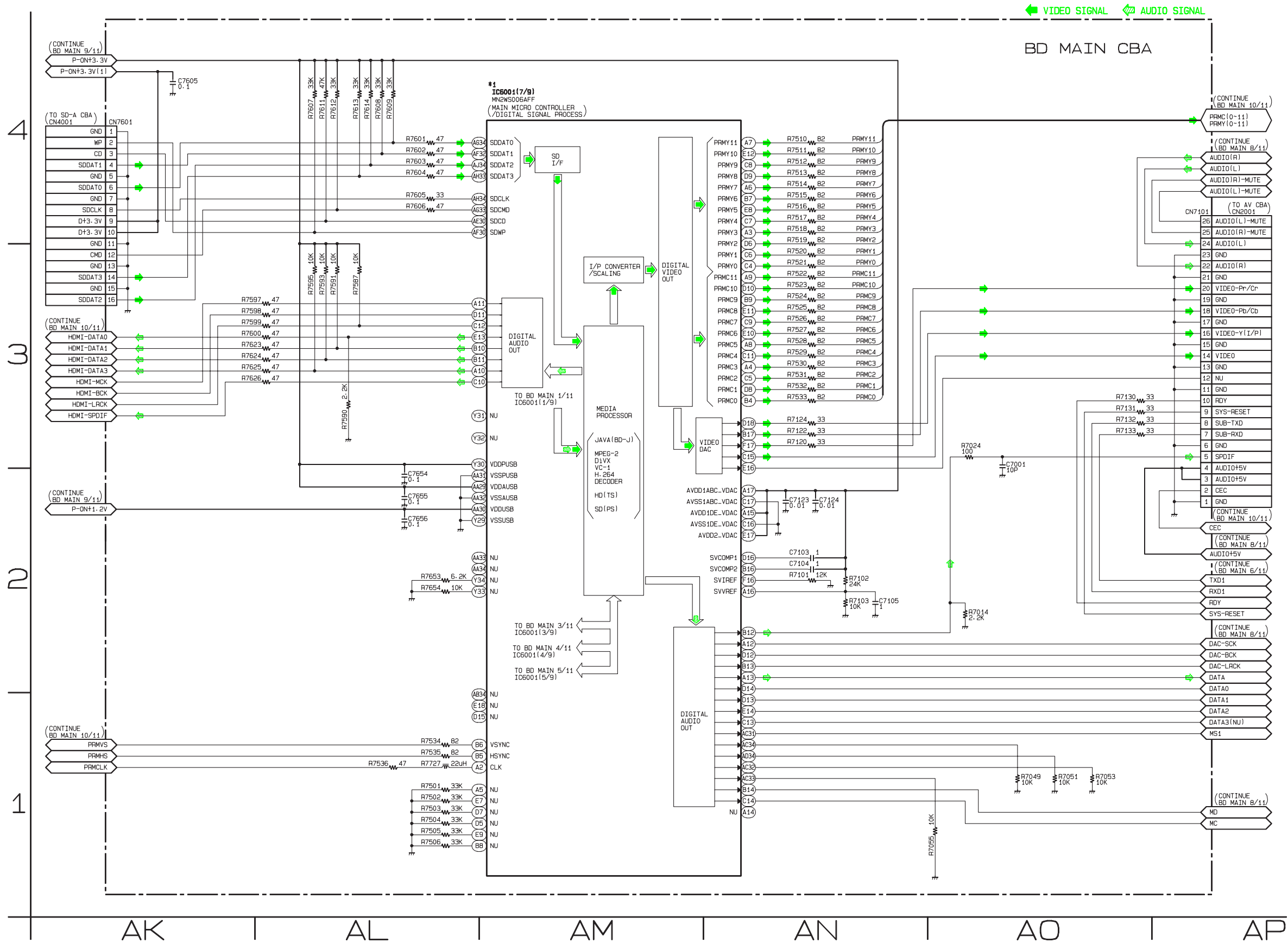

BD Main 8/11 Schematic Diagram

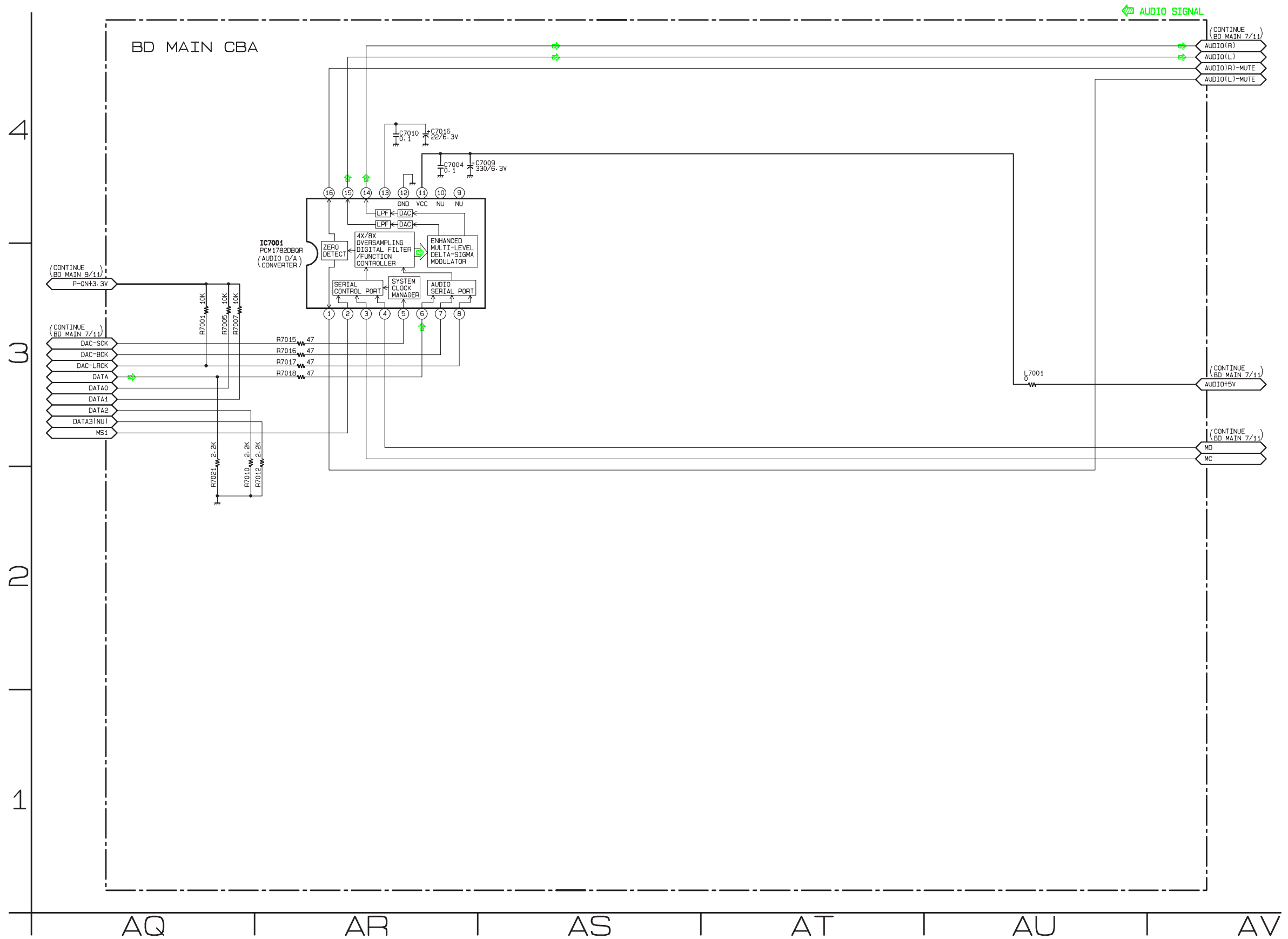

BD Main 9/11 Schematic Diagram

***1 NOTE:**

The order of pins shown in this diagram is different from that of actual IC6001.
 IC6001 is divided into nine and shown as IC6001 (1/9) ~ IC6001 (9/9) in this BD Main Schematic Diagram Section.

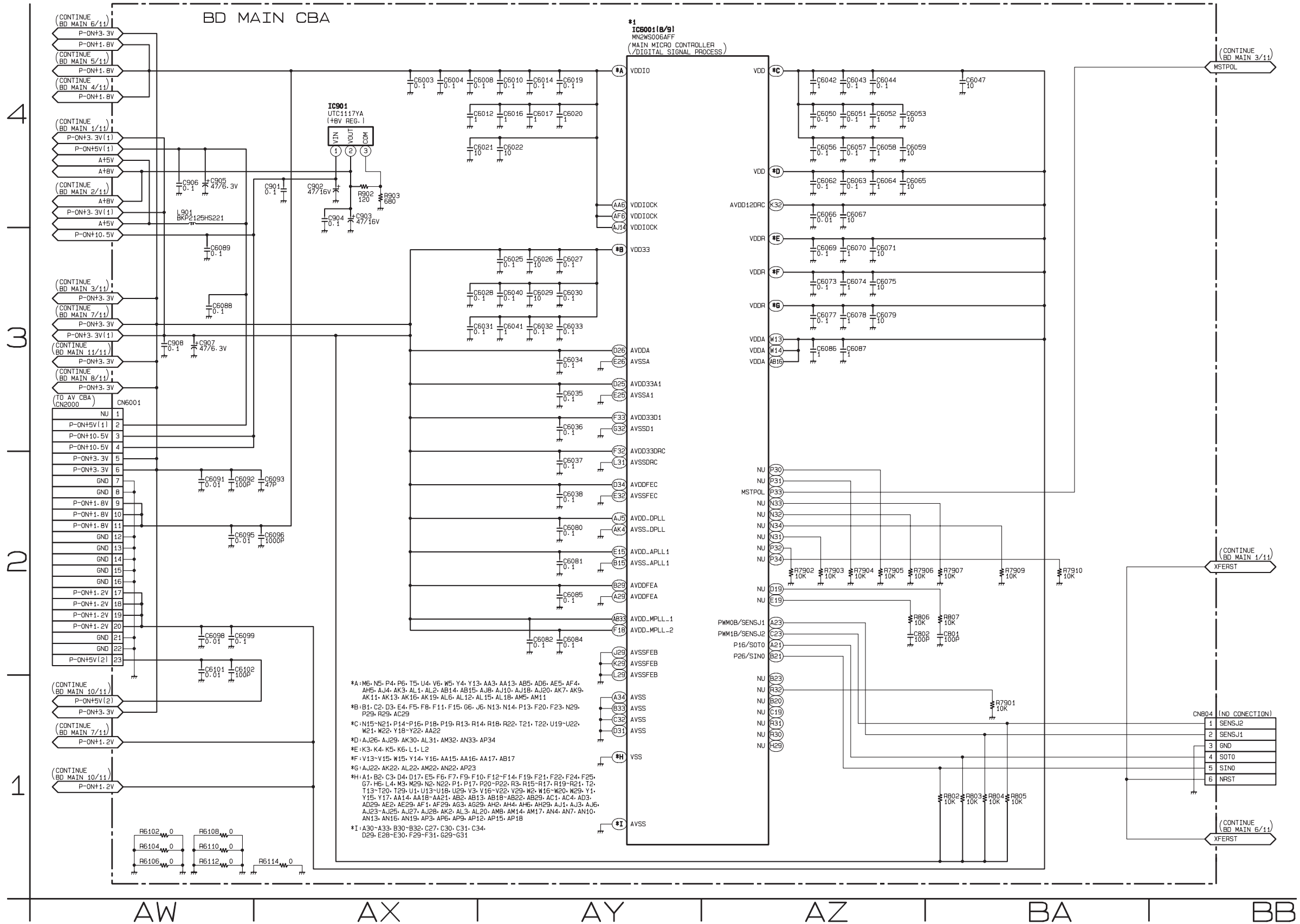

BD Main 10/11 Schematic Diagram

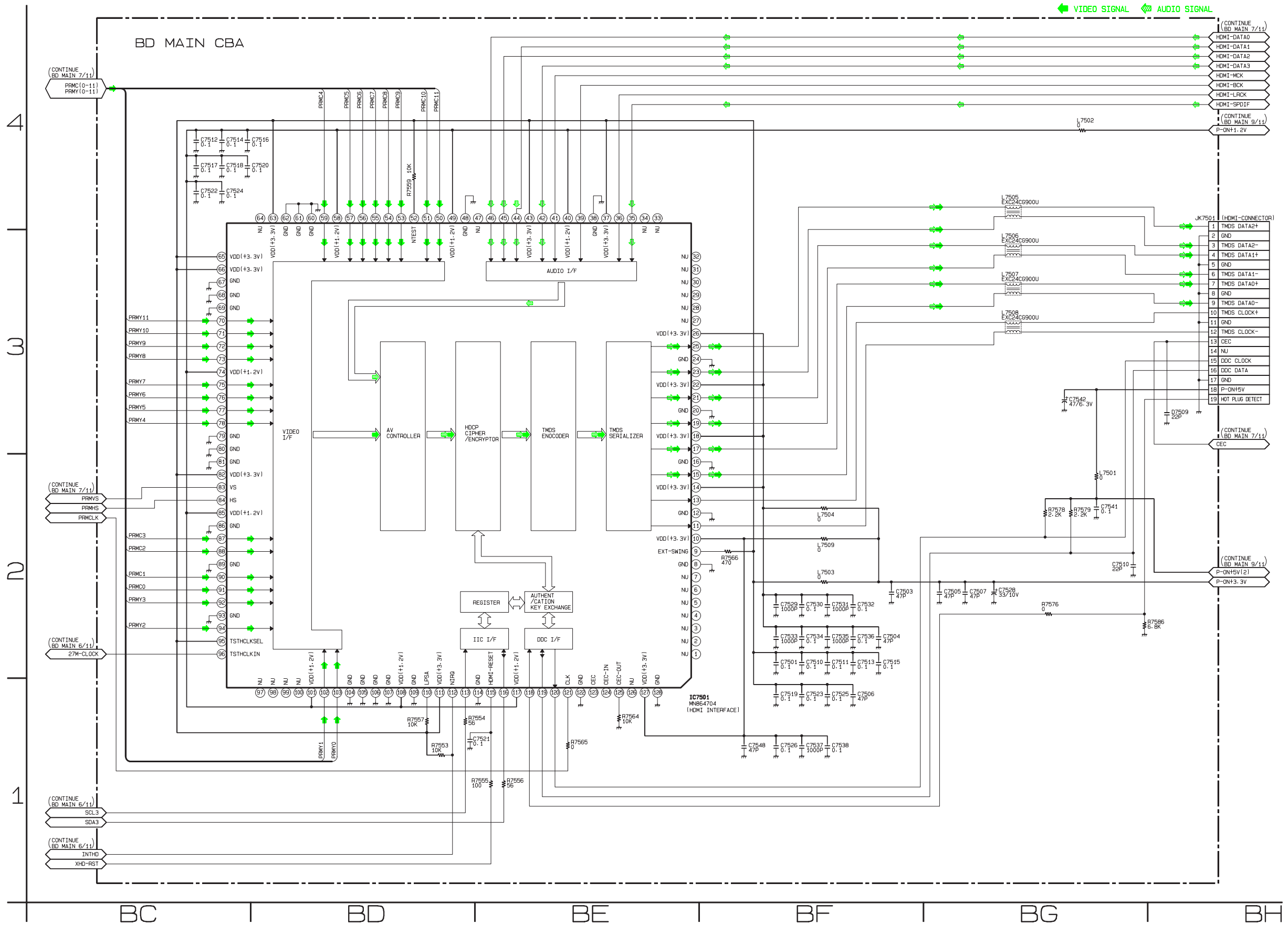

BD Main 11/11 Schematic Diagram

***1 NOTE:**

The order of pins shown in this diagram is different from that of actual IC6001.
 IC6001 is divided into nine and shown as IC6001 (1/9) ~ IC6001 (9/9) in this BD Main Schematic Diagram Section.

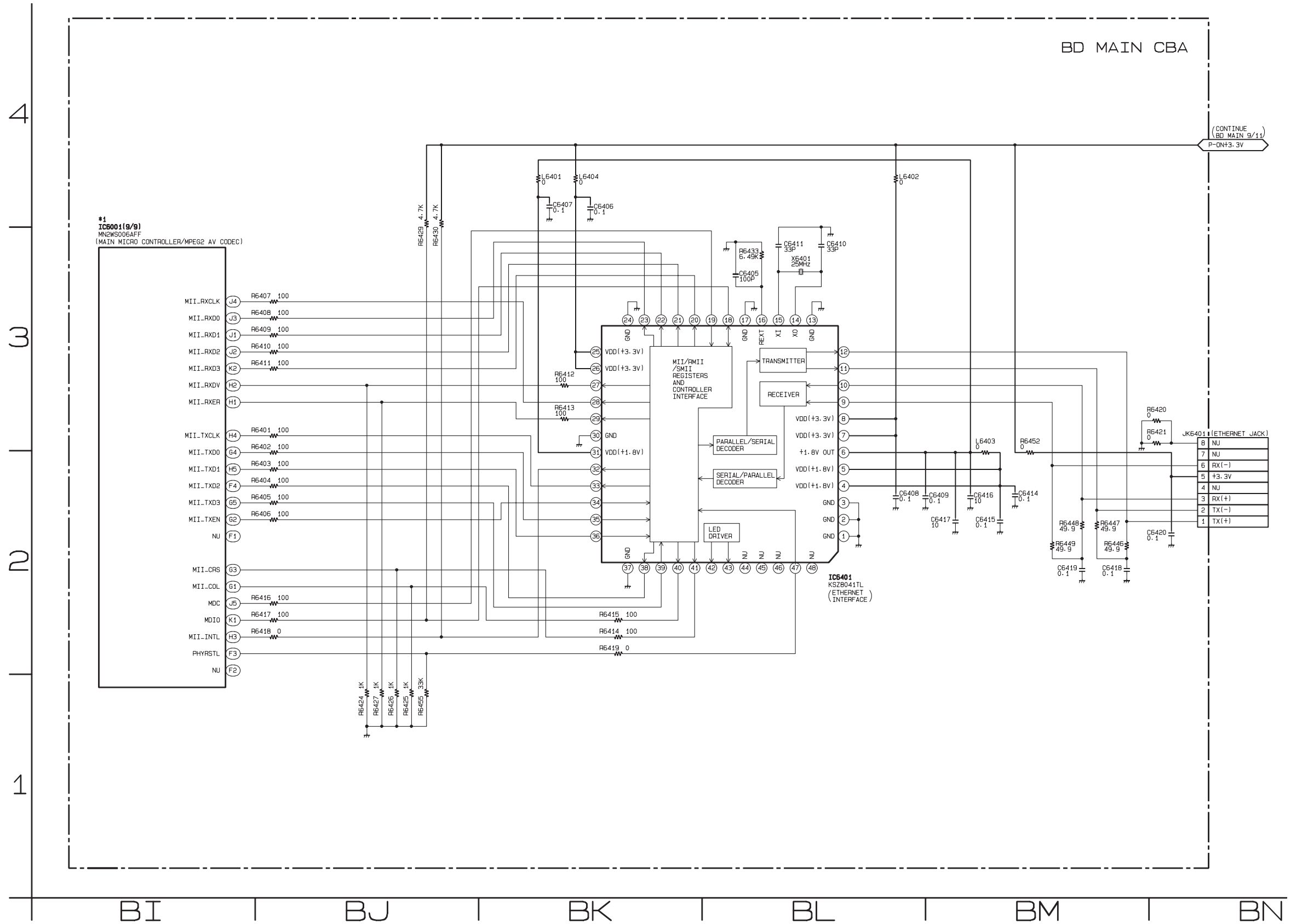

AV CBA Top View

CAUTION !

Fixed voltage (or Auto voltage selectable) power supply circuit is used in this unit.
If Main Fuse (F1001) is blown, check to see that all components in the power supply circuit are not defective before you connect the AC plug to the AC power supply.
Otherwise it may cause some components in the power supply circuit to fail.

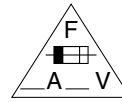

CAUTION !

For continued protection against fire hazard, replace only with the same type fuse.
ATTENTION : Pour une protection continue les risques d'Incele n'utiliser que des fusible de même type.
Risk of fire-replace fuse as marked.

■ This symbol means fast operating fuse.
"Ce symbole représente un fusible à fusion rapide."

Because a hot chassis ground is present in the power supply circuit, an isolation transformer must be used.
Also, in order to have the ability to increase the input slowly, when troubleshooting this type power supply circuit, a variable isolation transformer is required.

NOTE:

The voltage for parts in hot circuit is measured using hot GND as a common terminal.

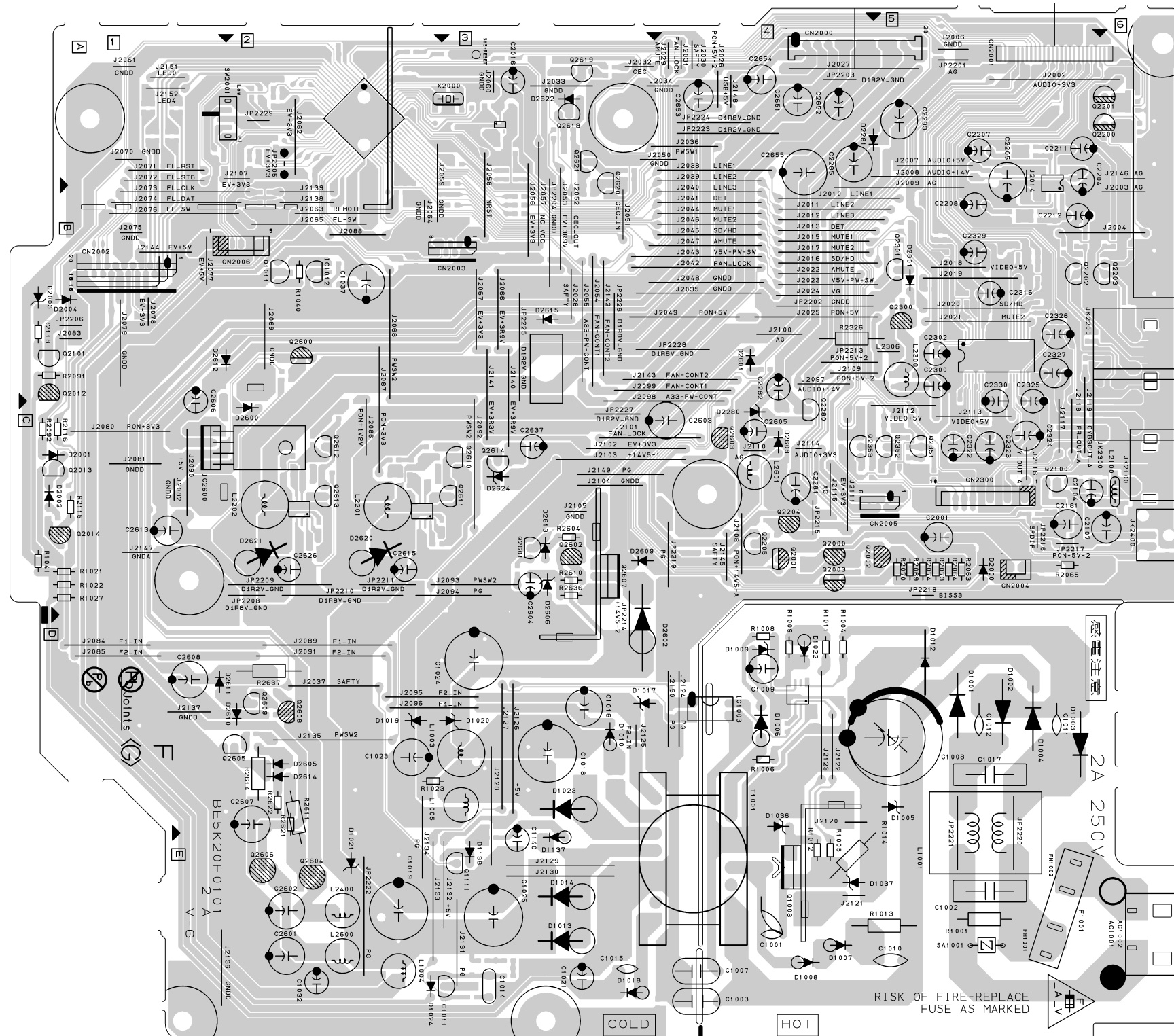

AV CBA Bottom View

CAUTION !

Fixed voltage (or Auto voltage selectable) power supply circuit is used in this unit.
If Main Fuse (F1001) is blown, check to see that all components in the power supply circuit are not defective before you connect the AC plug to the AC power supply.
Otherwise it may cause some components in the power supply circuit to fail.

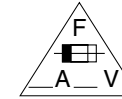

CAUTION !

For continued protection against fire hazard, replace only with the same type fuse.
ATTENTION : Pour une protection continue les risques d'incendie n'utiliser que des fusibles de même type.

Risk of fire-replace fuse as marked.

"This symbol means fast operating fuse."
"Ce symbole représente un fusible à fusion rapide."

NOTE:

The voltage for parts in hot circuit is measured using hot GND as a common terminal.

Because a hot chassis ground is present in the power supply circuit, an isolation transformer must be used. Also, in order to have the ability to increase the input slowly, when troubleshooting this type power supply circuit, a variable isolation transformer is required.

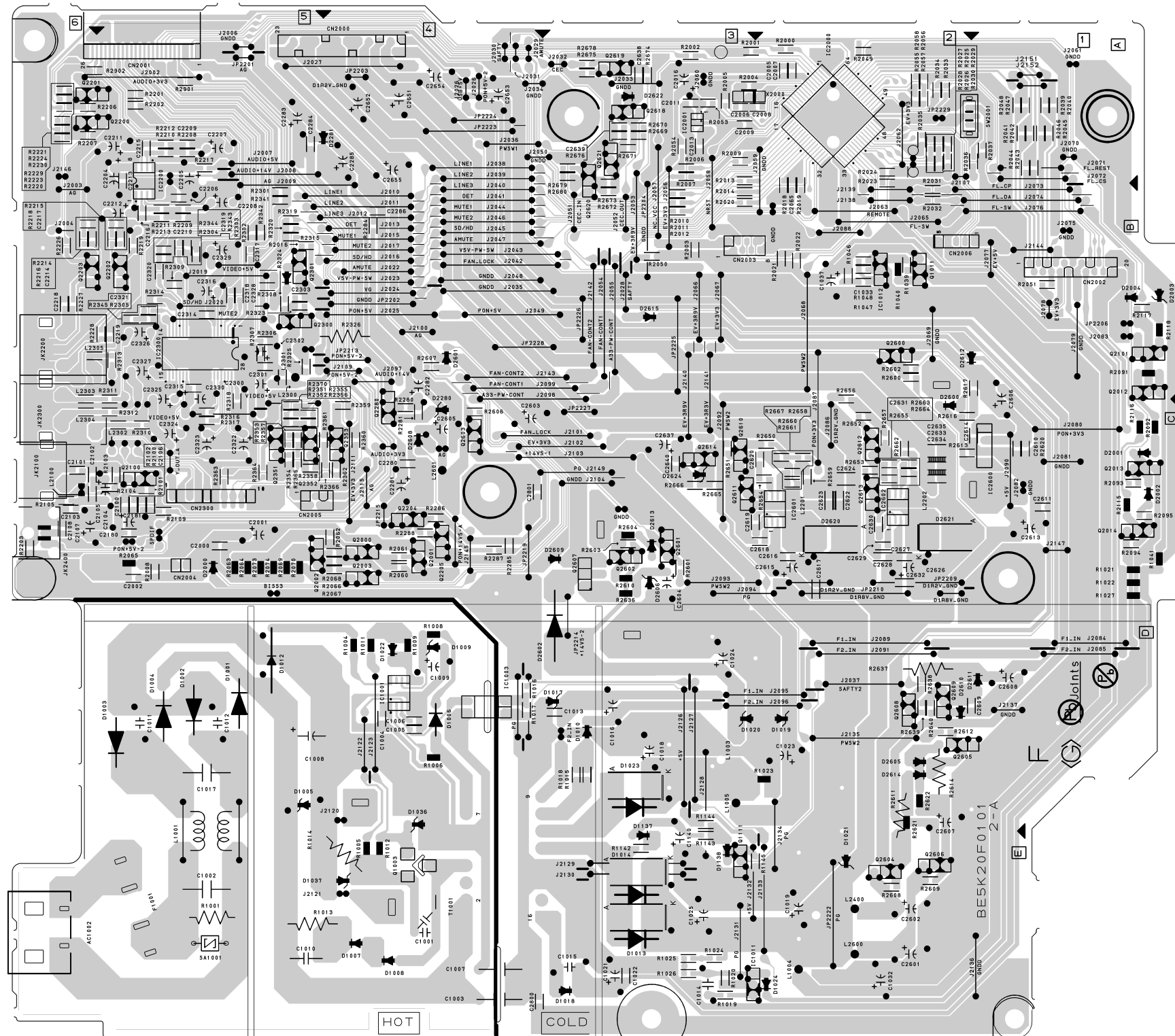

Front CBA Top View

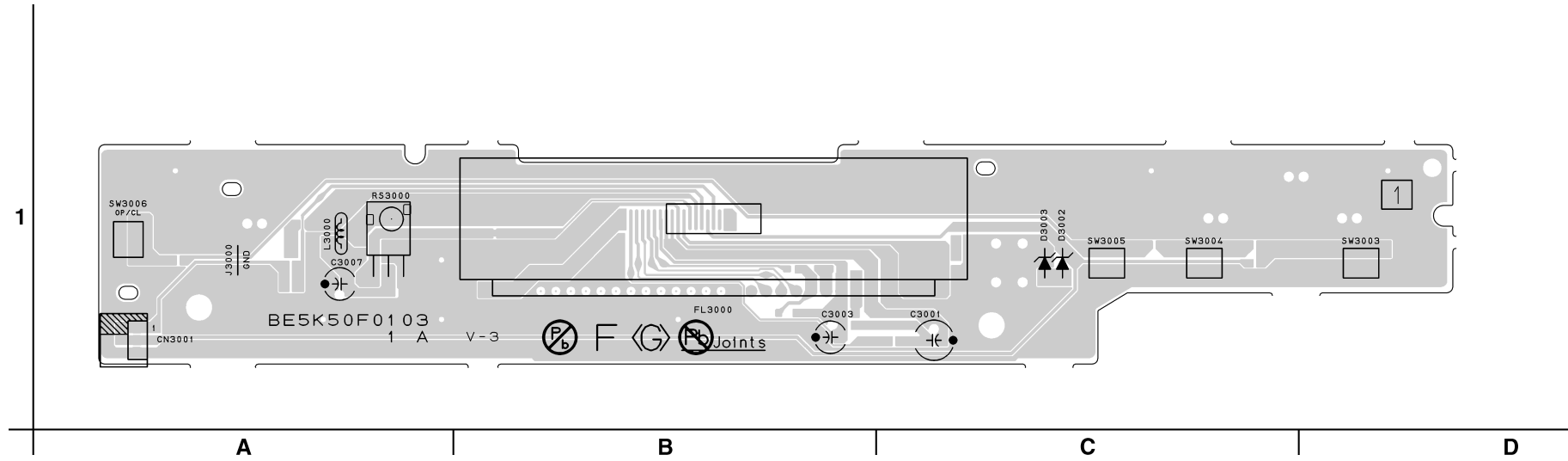

Power SW CBA Top View

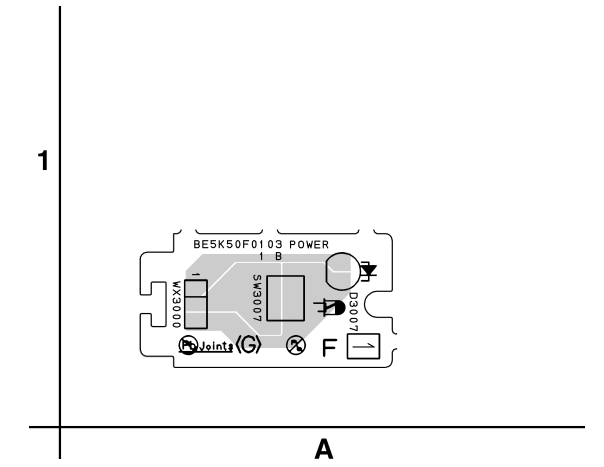

Front CBA Bottom View

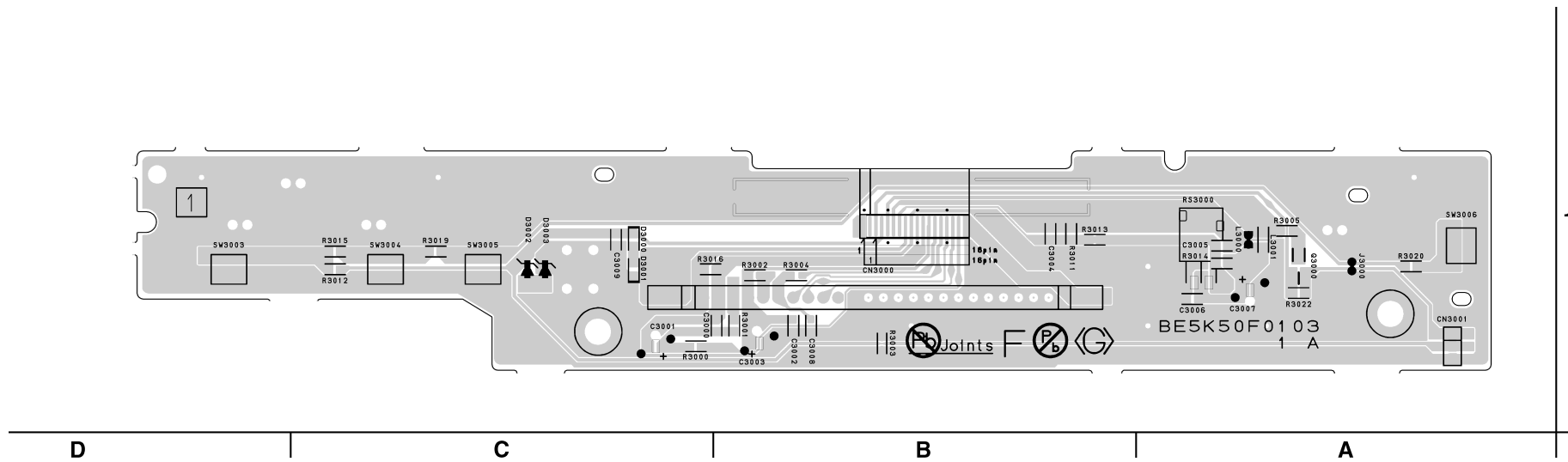

Power SW CBA Bottom View

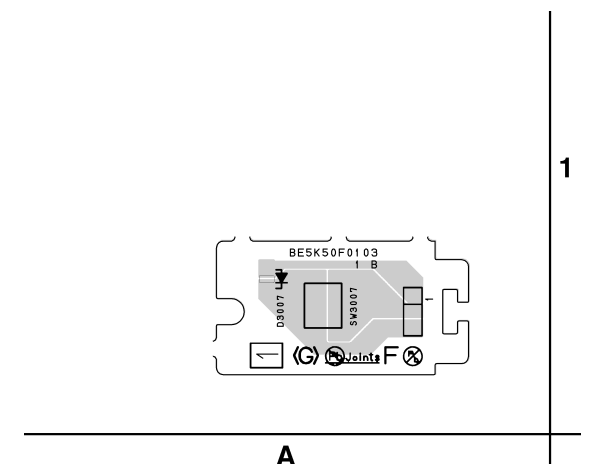

BE5K50F01031A

BE5K50F01031B

SD-A CBA Top View

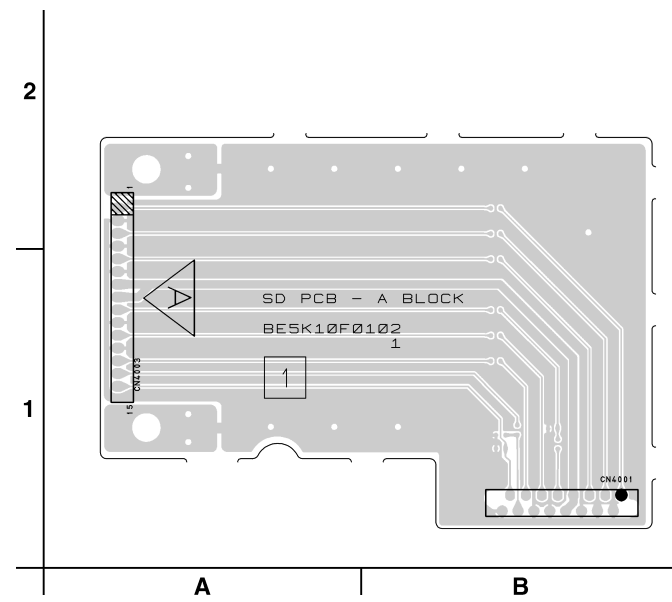

SD-B CBA Top View

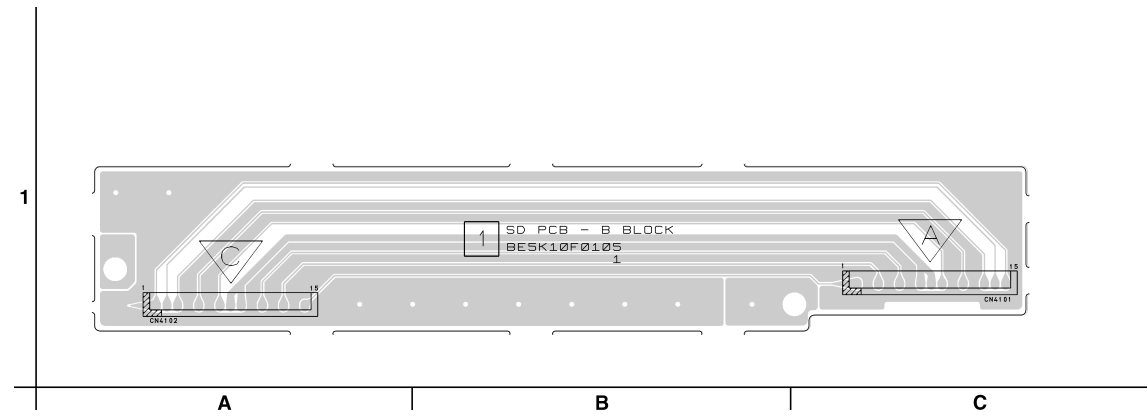

SD-C CBA Top View

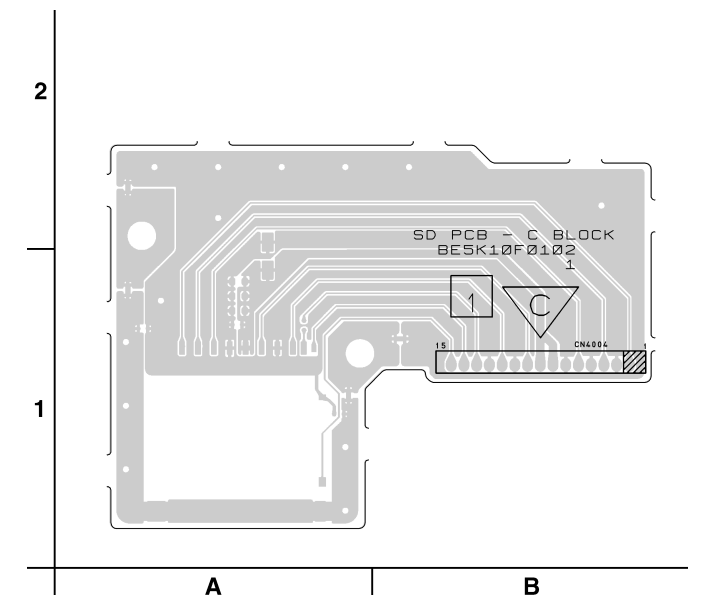

SD-A CBA Bottom View

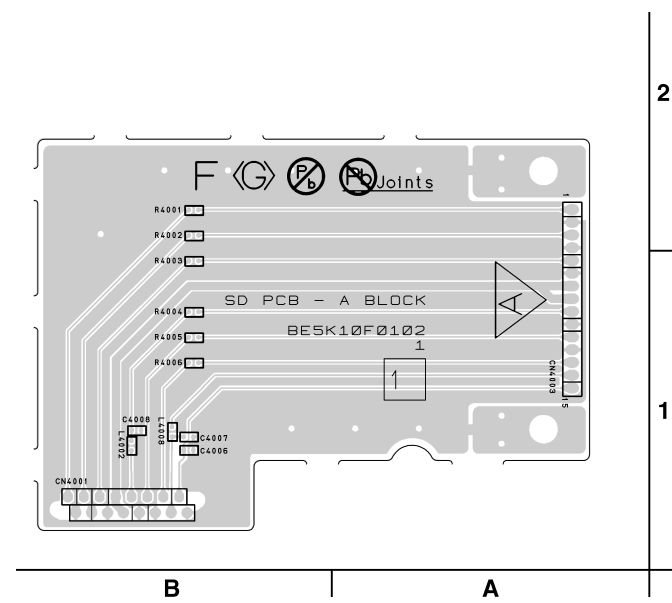

SD-B CBA Bottom View

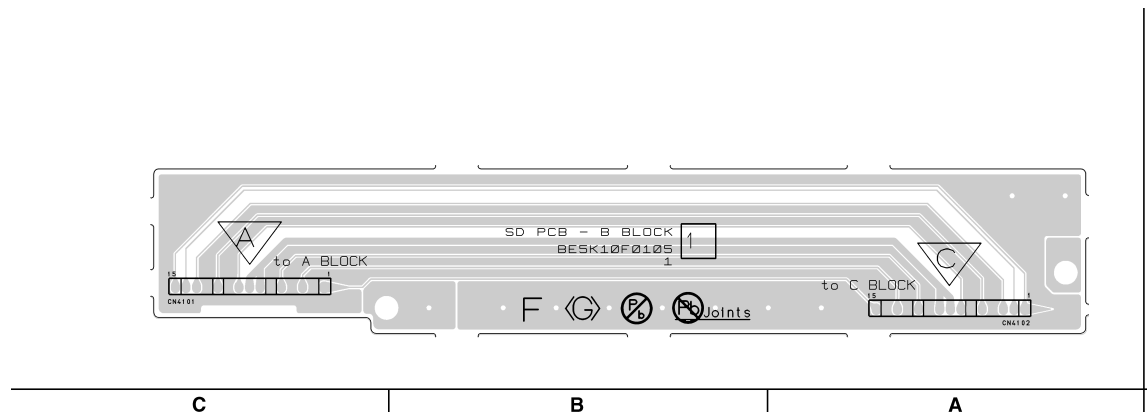

SD-C CBA Bottom View

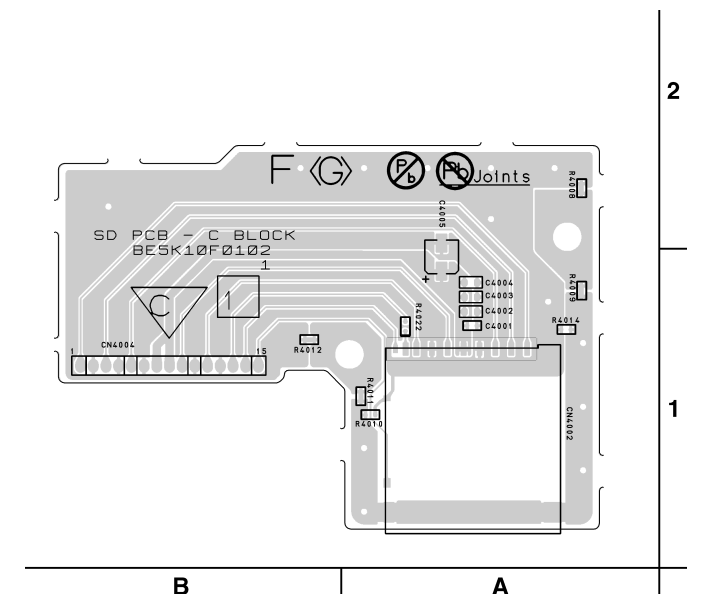

BE5K10F01021A

BE5K10F01051

BE5K10F01021C

EXPLODED VIEWS

Cabinet

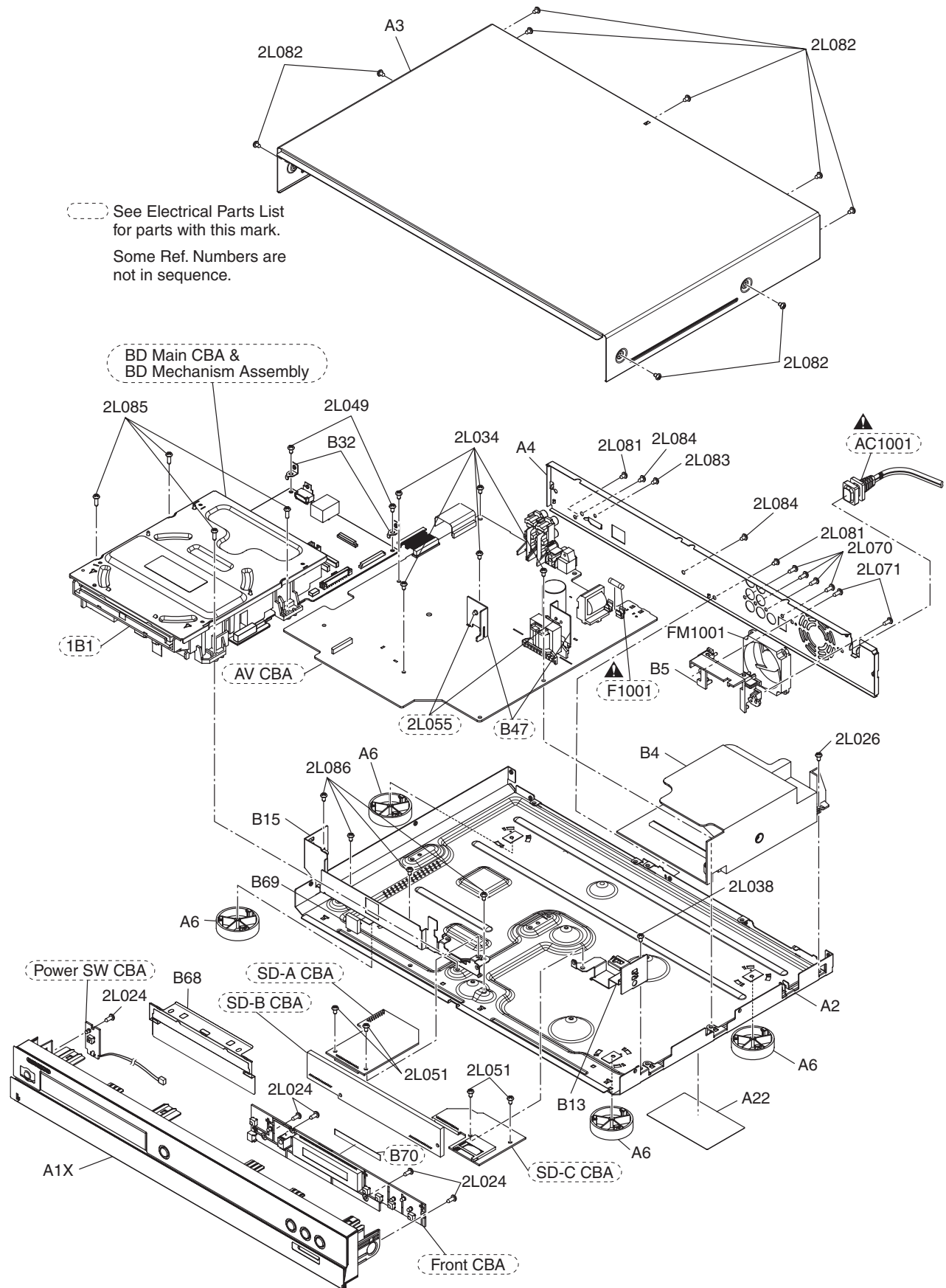

Packing

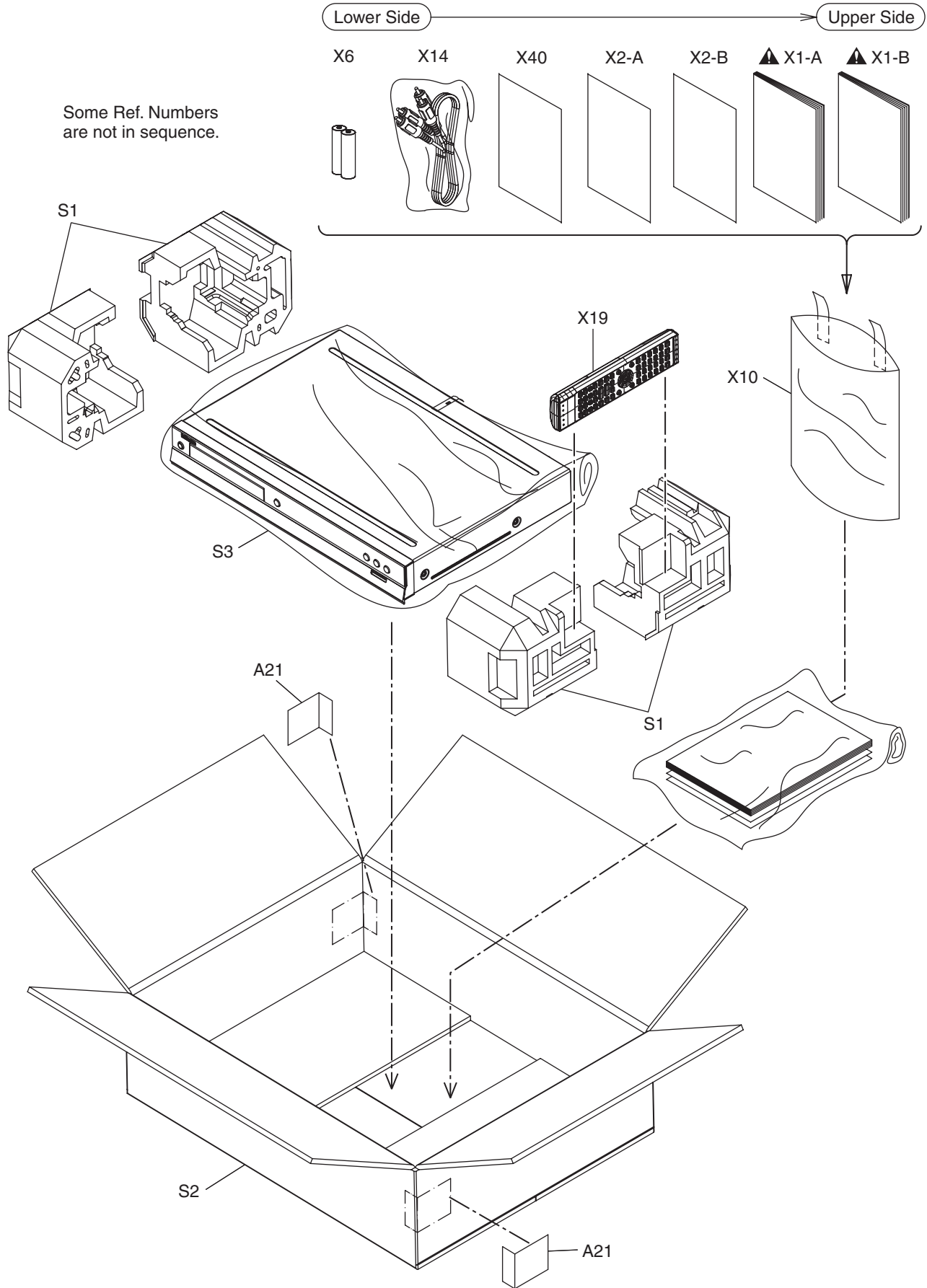

MECHANICAL PARTS LIST

PRODUCT SAFETY NOTE: Products marked with a  have special characteristics important to safety. Before replacing any of these components, read carefully the product safety notice in this service manual. Don't degrade the safety of the product through improper servicing.

NOTE: Parts that are not assigned part numbers (-----) are not available.

Ref. No.	Description	Part No.
A1X	FRONT ASSEMBLY E5K50UD	1VM123179
A2	CHASSIS E5K50UD	1VM330278
A3	TOP COVER E5K20UD	1VM122080
A4	REAR PANEL E5K50UD	1VM227696
A6	FOOT ASSEMBLY E5H50UD	1VM430199A
A21	BAR CODE LABEL E5K50UD	-----
A22	LICENSE LABEL E5K12UD	-----
2L024	SCREW P-TIGHT M3X8 BIND HEAD+	GBJP3080
2L026	SCREW C-TIGHT M3X6 E5610UD	0VM412937A
2L034	SCREW C-TIGHT M3X6 E5610UD	0VM412937A
2L038	SCREW C-TIGHT M3X6 E5610UD	0VM412937A
2L049	SCREW C-TIGHT M3X6 E5610UD	0VM412937A
2L051	SCREW C-TIGHT M3X6 E5610UD	0VM412937A
2L070	B-TIGHT SCREW M3X8 E5E00UD	1VM428563
2L071	B-TIGHT SCREW M3X8 E5E00UD	1VM428563
2L081	S-TIGHT SCREW M3X6 E5E00UD	1VM428564
2L082	SCREW TAP TIGHT M3X5 BIND HEAD+BLK NI	GBHC3050
2L083	S-TIGHT SCREW M3X6 E5E00UD	1VM428564
2L084	S-TIGHT SCREW M3X6 E5E00UD	1VM428564
2L085	SCREW S-TIGHT M3X10 E5610UD	0VM412936A
2L086	SCREW S-TIGHT M3X5 E5K10UD	1VM431079
B4	POWER HOLDER E5K20UD	1VM225697
B5	FAN HOLDER E6700UD	1VM320504L
B13	SD PCB BRACKET E5K10UD	1VM329203
B15	SHIELD BRACKET E5K10UD	1VM226756
B32	MAIN PCB EARTH PLATE E5K20UD	1VM430800
B68	FRONT SHIELD E5K20UD	1VM328838
B69	PORON SPONGE E5K20UD	1VM431100
FM1001	MOTOR DC FAN 2D57NL100010	MMEZR12XNR05
PACKING		
S1	SIDE PAD E5K50UD	1VM123159
S2	GIFT BOX CARTON E5K50UD	1VM330520
S3	SET BAG E7708UA	ODM400731D
ACCESSORIES		
X1-A 	OWNERS MANUAL(EN) E5K50UD	1VMN27515
X1-B 	OWNERS MANUAL(ES/FR) E5K50UD	1VMN27615
X2-A	QUICK GUIDE(EN) E5K50UD	1VMN27593
X2-B	QUICK GUIDE(ES/FR) E5K50UD	1VMN27616
X6	MANGANESE DRY BATTERY R6UWC/2STA	XB0M311MS003
X10	ACCESSORY BAG E5795ED	0VM416059
X14	AV CORD 1000/BLACK	WFPZ0102TM018
X19	REMOTE CONTROL UNIT NB821UD	NB821UD
X40	WARRANTY CARD E5H50UD	1VMN26325

ELECTRICAL PARTS LIST

PRODUCT SAFETY NOTE: Products marked with a **▲** have special characteristics important to safety. Before replacing any of these components, read carefully the product safety notice in this service manual. Don't degrade the safety of the product through improper servicing.

NOTES:

- Parts that are not assigned part numbers (-----) are not available.
- Tolerance of Capacitors and Resistors are noted with the following symbols.

C.....±0.25% D.....±0.5% F.....±1%
 G.....±2% J.....±5% K.....±10%
 M.....±20% N.....±30% Z.....+80/-20%

BD MAIN CBA & BD MECHANISM ASSEMBLY

Ref. No.	Description	Part No.
1B1	BD MAIN CBA & BD MECHANISM ASSEMBLY	N77R0BUN

AV CBA

Ref. No.	Description	Part No.
	AV CBA Consists of the following:	1VSA22027
CAPACITORS		
C1001	CAP CERAMIC 470pF/2KV/K	CA3D471PAN17
C1002▲	LINE ACROSS CAP. 0.047µF/250V K	CT2E473DC016
C1004	CHIP CERAMIC CAP.(1608) CH J 22pF/50V	CHD1JJ3CH220
C1005	CHIP CERAMIC CAP.(1608) B K 1000pF/50V	CHD1JK30B102
C1006	CHIP CERAMIC CAP.(1608) B K 0.033µF/50V	CHD1JK30B333
C1007▲	SAFETY CAP. 3300pF/250V	CCD2EMA0E332
C1008	ELECTROLYTIC CAPACITOR ZR200TA221K18EB	CA2D221DYG04
C1009	ELECTROLYTIC CAP. 47µF/35V/M	CEE47RENW016
C1010	METALIZED FILM CAP. 0.0022µF/400V K	CT2H222DT034
C1013	CHIP CERAMIC CAP.(1608) B K 0.01µF/50V	CHD1JK30B103
C1014	POLYESTER FILM CAP. (PB FREE) 0.0068µF/ 100V J	CA2A682DT018
C1015	CERAMIC CAP. B K 470pF/500V	CCD2JKS0B471
C1016	ELECTROLYTIC CAP. 220µF/10V M	CEB221ENW016
C1017▲	LINE ACROSS CAP. 0.047µF/250V K	CT2E473DC016
C1018	ELECTROLYTIC CAP 2200µF/25V/M	CED222ENW009
C1019	ELECTROLYTIC CAP 4700µF/6.3V/M	CEA472ENW009
C1021	ELECTROLYTIC CAP. 22µF/50V/M	CEF22RENW016
C1022	CHIP CERAMIC CAP.(1608) F Z 0.1µF/50V	CHD1JZ30F104
C1023	ELECTROLYTIC CAP. 220µF/25V/M	CED221ENW016
C1024	ELECTROLYTIC CAP 2200µF/25V/M	CED222ENW009
C1025	ELECTROLYTIC CAP 4700µF/6.3V/M	CEA472ENW009
C1032	ELECTROLYTIC CAP. 100µF/6.3V/M	CEA101ENW016
C1033	CHIP CERAMIC CAP.(1608) B K 0.01µF/50V	CHD1JK30B103
C1037	ELECTROLYTIC CAP. 47µF/6.3V/M	CEA47RENW016
C1140	ELECTROLYTIC CAP. 22µF/50V/M	CEF22RENW016
C2000	CHIP CERAMIC CAP.(1608) B K 0.1µF/25V	CHD1EK30B104
C2001	ELECTROLYTIC CAP. 100µF/16V/M	CEC101ENW016
C2002	CHIP CERAMIC CAP.(1608) B K 0.1µF/25V	CHD1EK30B104
C2005	CHIP CERAMIC CAP.(1608) F Z 0.1µF/50V	CHD1JZ30F104

Ref. No.	Description	Part No.
C2007	CHIP CERAMIC CAP.(1608) F Z 0.1µF/50V	CHD1JZ30F104
C2009	CHIP CERAMIC CAP.(1608) CH J 100pF/50V	CHD1JJ3CH101
C2011	CHIP CERAMIC CAP.(1608) F Z 0.1µF/50V	CHD1JZ30F104
C2013	CHIP CERAMIC CAP.(1608) B K 0.015µF/50V	CHD1JK30B153
C2016	ELECTROLYTIC CAP. 47µF/6.3V/M	CEA47RENW016
C2065	CHIP CERAMIC CAP.(1608) B K 1000pF/50V	CHD1JK30B102
C2100	CHIP CERAMIC CAP.(1608) B K 0.1µF/25V	CHD1EK30B104
C2104	ELECTROLYTIC CAP. 47µF/6.3V/M	CEA47RENW016
C2106	CHIP CERAMIC CAP. CH D 8pF/50V	CHD1JD3CH8R0
C2108	CHIP CERAMIC CAP.(1608) F Z 0.1µF/50V	CHD1JZ30F104
C2180	CHIP CERAMIC CAP.(1608) F Z 0.1µF/50V	CHD1JZ30F104
C2181	ELECTROLYTIC CAP. 220µF/6.3V/M	CEA221ENW016
C2204	ELECTROLYTIC CAP. 47µF/25V/M	CEA47RENW016
C2205	ELECTROLYTIC CAP. 470µF/6.3V/M	CEA471ENW016
C2206	CHIP CERAMIC CAP.(1608) F Z 0.1µF/50V	CHD1JZ30F104
C2207	ELECTROLYTIC CAP. 10µF/16V/M	CEC10RENW016
C2208	ELECTROLYTIC CAP. 10µF/16V/M	CEC10RENW016
C2209	CHIP CERAMIC CAP. CH J 220pF/50V	CHD1JJ3CH221
C2210	CHIP CERAMIC CAP. CH J 220pF/50V	CHD1JJ3CH221
C2211	ELECTROLYTIC CAP. 10µF/16V/M	CEC10RENW016
C2212	ELECTROLYTIC CAP. 10µF/16V/M	CEC10RENW016
C2213	CHIP CERAMIC CAP.(1608) F Z 0.1µF/50V	CHD1JZ30F104
C2215	CHIP CERAMIC CAP. CH J 39pF/50V	CHD1JJ3CH390
C2216	CHIP CERAMIC CAP. CH J 39pF/50V	CHD1JJ3CH390
C2280	CHIP CERAMIC CAP.(1608) F Z 0.1µF/50V	CHD1JZ30F104
C2281	ELECTROLYTIC CAP. 220µF/6.3V/M	CEA221ENW016
C2283	ELECTROLYTIC CAP. 1000µF/6.3V/M	CEA102ENW016
C2284	CHIP CERAMIC CAP.(1608) F Z 0.1µF/50V	CHD1JZ30F104
C2286	CHIP CERAMIC CAP.(1608) F Z 0.1µF/50V	CHD1JZ30F104
C2300	ELECTROLYTIC CAP. 100µF/6.3V/M	CEA101ENW016
C2301	CHIP CERAMIC CAP.(1608) F Z 0.1µF/50V	CHD1JZ30F104
C2314	CHIP CERAMIC CAP.(1608) F Z 0.1µF/50V	CHD1JZ30F104
C2315	CHIP CERAMIC CAP.(1608) F Z 0.1µF/50V	CHD1JZ30F104
C2316	ELECTROLYTIC CAP. 22µF/6.3V/M	CEA22RENW016
C2319	CHIP CERAMIC CAP.(1608) B K 0.1µF/50V	CHD1JK30B104
C2320	CHIP CERAMIC CAP.(1608) B K 1µF/10V	CHD1AK30B105
C2321	CHIP CERAMIC CAP.(1608) B K 1µF/10V	CHD1AK30B105
C2322	ELECTROLYTIC CAP. 33µF/10V/M	CEB33RENW016
C2323	ELECTROLYTIC CAP. 330µF/6.3V/M	CEA331ENW016
C2324	ELECTROLYTIC CAP. 330µF/6.3V/M	CEA331ENW016
C2325	ELECTROLYTIC CAP. 33µF/10V/M	CEB33RENW016
C2326	ELECTROLYTIC CAP. 330µF/6.3V/M	CEA331ENW016
C2327	ELECTROLYTIC CAP. 330µF/6.3V/M	CEA331ENW016
C2328	CHIP CERAMIC CAP.(1608) B K 0.1µF/50V	CHD1JK30B104
C2329	ELECTROLYTIC CAP. 100µF/6.3V/M	CEA101ENW016
C2330	ELECTROLYTIC CAP. 100µF/6.3V/M	CEA101ENW016
C2601	ELECTROLYTIC CAP. 1000µF/6.3V/M	CEA102ENW016
C2602	ELECTROLYTIC CAP. 1000µF/6.3V/M	CEA102ENW016
C2604	ELECTROLYTIC CAP. 10µF/16V/M	CEC10RENW016
C2605	ELECTROLYTIC CAP. 47µF/25V/M	CED47RENW016
C2606	ELECTROLYTIC CAP. 100µF/6.3V/M	CEA101ENW016
C2607	ELECTROLYTIC CAP. 1000µF/6.3V/M	CEA102ENW016
C2609	CHIP CERAMIC CAP.(1608) B K 1µF/10V	CHD1AK30B105
C2610	CHIP CERAMIC CAP.(1608) B K 0.1µF/25V	CHD1EK30B104
C2613	ELECTROLYTIC CAP. 220µF/6.3V/M	CEA221ENW016
C2614	CHIP CERAMIC CAP.(1608) B K 0.33µF/10V	CHD1AK30B334
C2616	CHIP CERAMIC CAP.(1608) B K 1µF/10V	CHD1AK30B105
C2618	CHIP CERAMIC CAP.(1608) F Z 0.1µF/50V	CHD1JZ30F104
C2619	CHIP CERAMIC CAP.(1608) F Z 0.1µF/50V	CHD1JZ30F104
C2620	CHIP CERAMIC CAP. B K 8200pF/50V	CHD1JK30B822

Ref. No.	Description	Part No.
C2622	CHIP CERAMIC CAP(2125) B K 10 μ F/6.3V	CHE0KK30B106
C2623	CHIP CERAMIC CAP(2125) B K 10 μ F/6.3V	CHE0KK30B106
C2627	CHIP CERAMIC CAP(1608) B K 1 μ F/10V	CHD1AK30B105
C2629	CHIP CERAMIC CAP(1608) F Z 0.1 μ F/50V	CHD1JZ30F104
C2630	CHIP CERAMIC CAP(1608) F Z 0.1 μ F/50V	CHD1JZ30F104
C2631	CHIP CERAMIC CAP(1608) B K 5600pF/50V	CHD1JK30B562
C2632	CHIP CERAMIC CAP(2125) B K 10 μ F/6.3V	CHE0KK30B106
C2633	CHIP CERAMIC CAP(2125) B K 10 μ F/6.3V	CHE0KK30B106
C2634	CHIP CERAMIC CAP(2125) B K 10 μ F/6.3V	CHE0KK30B106
C2638	CHIP CERAMIC CAP. CH J 330pF/50V	CHD1J3CH331
C2639	CHIP CERAMIC CAP. CH J 220pF/50V	CHD1J3CH221
C2640	CHIP CERAMIC CAP(1608) B K 0.01 μ F/50V	CHD1JK30B103
C2652	ELECTROLYTIC CAP. 330 μ F/6.3V/M	CEA331ENW016
C2653	ELECTROLYTIC CAP. 330 μ F/6.3V/M	CEA331ENW016
C2655	ELECTROLYTIC CAP. 470 μ F/16V/M	CEC471ENW016
C2800	CHIP CERAMIC CAP(1608) B K 0.01 μ F/50V	CHD1JK30B103
C2801	CHIP RES.(1608) 1/10W 0 Ω	RRXAZR5Z0000
CONNECTORS		
CN2000	TWG CONNECTOR 23P TWG-P23P-A1	J3TWA23TG001
CN2001	WIRE ASSEMBLY AV-MAIN 26P WX1E5K20-001	WX1E5K20-001
CN2002	FFC CONNECTOR IMSA-9615S-16A-PP-A	JC96J16ER007
CN2004	PH CONNECTOR TOP 2P B2B-PH-K-S (LF)(SN)	J3PHC02JG029
DIODES		
D1001	DIODE 1N5397-B	NDLZ001N5397
D1002	DIODE 1N5397-B	NDLZ001N5397
D1003	DIODE 1N5397-B	NDLZ001N5397
D1004	DIODE 1N5397-B	NDLZ001N5397
D1006	DIODE FR154	NDLZ000FR154
D1007	RECTIFIER DIODE BA157	NDQZ000BA157
D1008	RECTIFIER DIODE BA157	NDQZ000BA157
D1010	RECTIFIER DIODE BA157	NDQZ000BA157
D1012	PCB JUMPER D0.6-P15.0	JW15.0T
D1013	SCHOTTKY BARRIER DIODE SMD SK54	ND1Z0000SK54
D1014	SCHOTTKY BARRIER DIODE SMD SK54	ND1Z0000SK54
D1017	DIODE ZENER 5V1BSB-T26	NDTB5R1BST26
D1018	RECTIFIER DIODE BA157	NDQZ000BA157
D1019	DIODE ZENER 18BSB-T26	NDTB018BST26
D1020	DIODE ZENER 18BSB-T26	NDTB018BST26
D1021	DIODE ZENER 6V8BSB-T26	NDTB6R8BST26
D1022	SCHOTTKY BARRIER DIODE SB140	NDQZ000SB140
D1023	SCHOTTKY BARRIER DIODE SMD SK39	ND1Z0000SK39
D1024	DIODE SWITCHING 1N4148-F0021	NDT201N4148F
D1036	DIODE ZENER 27BSB-T26	NDTB027BST26
D1037	DIODE ZENER 27BSB-T26	NDTB027BST26
D1137	RECTIFIER DIODE BA157	NDQZ000BA157
D1138	DIODE SWITCHING 1N4148-F0021	NDT201N4148F
D2001	DIODE SWITCHING 1N4148-F0021	NDT201N4148F
D2002	DIODE SWITCHING 1N4148-F0021	NDT201N4148F
D2003	DIODE ZENER 36BSA-T26	NDTA036BST26
D2004	DIODE SWITCHING 1N4148-F0021	NDT201N4148F
D2600	DIODE SWITCHING 1N4148-F0021	NDT201N4148F
D2601	DIODE SWITCHING 1N4148-F0021	NDT201N4148F
D2602	DIODE 1N5406	NDLZ001N5406
D2605	DIODE SWITCHING 1N4148-F0021	NDT201N4148F
D2606	DIODE ZENER 11BSC-T26	NDTC011BST26
D2608	DIODE SWITCHING 1N4148-F0021	NDT201N4148F
D2609	DIODE SWITCHING 1N4148-F0021	NDT201N4148F
D2610	DIODE SWITCHING 1N4148-F0021	NDT201N4148F
D2612	DIODE SWITCHING 1N4148-F0021	NDT201N4148F
D2613	DIODE SWITCHING 1N4148-F0021	NDT201N4148F
D2614	DIODE SWITCHING 1N4148-F0021	NDT201N4148F

Ref. No.	Description	Part No.
D2615	DIODE SWITCHING 1N4148-F0021	NDT201N4148F
D2620	SCHOTTKY BARRIER DIODE SMD SK34	ND1Z0000SK34
D2621	SCHOTTKY BARRIER DIODE SMD SK34	ND1Z0000SK34
D2624	DIODE ZENER 4V7BSB-T26	NDTB4R7BST26
ICS		
IC1001	IC SWITCHING FA5542N-A2-TE1 SOP8	QSZBA0TFD005
IC1003▲	PHOTOCOUPLER PS2561A-1(W)	QPEWPS2561A1
IC1011	IC SHUNT REGULATOR SL431A-AT	NSZBA0TAUK01
IC1012	IC SHUNT REGULATOR SL431A-AT	NSZBA0TAUK01
IC2000	IC SUB MICON MN101C77A GC	QSAAR0RMS010
IC2001	RESET IC S-80930CNMC-G80T2G	QSCA0T0SK018
IC2200	IC OP AMP UTC4580TE	NSCA0T02H001
IC2300	IC VIDEO DRIVER MM1757EHBE	QSCA0T0MM001
IC2600	IC VOLTAGE REGULATOR PQ070XFC1SZF / 4PIN	QSZBA0RSH083
IC2601	IC DC-DC CONVERTER BD9323EFJ-E2	QSCA0T0RM002
IC2602	IC DC-DC CONVERTER BD9323EFJ-E2	QSCA0T0RM002
COILS		
L1001▲	LINE FILTER 27MH 5703	LLBG00ZKT009
L1003	POWER INDUCTORS CWKBNP-220K	LLF2200KV002
L1004	RADIAL TYPE CHOKE COIL CW68-470K-841040NP	LLBD00PKV023
L1005	CHOKE COIL 22 μ H-K	LLBD00PKV021
L2100	INDUCTOR(0.47 μ H K) LAP02TAR47K	LLAXKATTUR47
L2201	POWER INDUCTORS CWKBNP-100K	LLF1000KV002
L2202	POWER INDUCTORS CWKBNP-100K	LLF1000KV002
L2300	RADIAL TYPE CHOKE COIL CW68-470K-841040NP	LLBD00PKV023
L2301	CHIP RES.(1608) 1/10W 0 Ω	RRXAZR5Z0000
L2306	PCB JUMPER D0.6-P5.0	JW5.0T
L2400	CHOKE COIL 22 μ H-K	LLBD00PKV021
L2600	CHOKE COIL 22 μ H-K	LLBD00PKV021
L2601	CHOKE COIL 22 μ H-K	LLBD00PKV021
TRANSISTORS		
Q1003▲	FET MOS 2SK3563(Q M)	QFQZSK3563QM
Q1011	NPN TRANSISTOR 2SC5344 Y	NQSY02SC5344
Q1111	NPN TRANSISTOR 2SC5343MG-AT	NQSG2SC5343M
Q2000	PNP TRANSISTOR 2SA1980M Y	NQSY2SA1980M
Q2001	NPN TRANSISTOR RES-IN SRC1203MAT	NQSZSRC1203M
Q2002	PNP TRANSISTOR 2SA1980M Y	NQSY2SA1980M
Q2003	NPN TRANSISTOR RES-IN SRC1203MAT	NQSZSRC1203M
Q2012	PNP TRANSISTOR 2SA1980M Y	NQSY2SA1980M
Q2013	NPN TRANSISTOR 2SC5343MG-AT	NQSG2SC5343M
Q2014	PNP TRANSISTOR 2SA1981Y-AT	NQSY02SA1981
Q2100	NPN TRANSISTOR 2SC5343MG-AT	NQSG2SC5343M
Q2101	NPN TRANSISTOR 2SC5343MG-AT	NQSG2SC5343M
Q2200	PNP TRANSISTOR RES-IN SRA2205M	NQZSRA2205M
Q2201	PNP TRANSISTOR RES-IN SRA2205M	NQZSRA2205M
Q2202	NPN TRANSISTOR 2SC5343MG-AT	NQSG2SC5343M
Q2203	NPN TRANSISTOR 2SC5343MG-AT	NQSG2SC5343M
Q2204	PNP TRANSISTOR 2SA1980M Y	NQSY2SA1980M
Q2205	NPN TRANSISTOR 2SC5343MG-AT	NQSG2SC5343M
Q2600	NPN TRANSISTOR RES-IN SRC1203MAT	NQSZSRC1203M
Q2601	NPN TRANSISTOR 2SC5343MG-AT	NQSG2SC5343M
Q2602	PNP TRANSISTOR 2SA1980M Y	NQSY2SA1980M
Q2603	PNP TRANSISTOR 2SA1981Y-AT	NQSY02SA1981
Q2604	PNP TRANSISTOR STB1277LY-AT	NQSYSTB1277L
Q2605	NPN TRANSISTOR 2SC5344 Y	NQSY02SC5344
Q2606	PNP TRANSISTOR STB1277LY-AT	NQSYSTB1277L
Q2607	TRANSISTOR(PB FREE) KTC2026-Y/P	NQEYKTC2026P
Q2608	PNP TRANSISTOR 2SA1980MG-AT	NQSG2SA1980M
Q2609	NPN TRANSISTOR 2SC5343MG-AT	NQSG2SC5343M
Q2610	NPN TRANSISTOR 2SC5343MG-AT	NQSG2SC5343M

Ref. No.	Description	Part No.
Q2611	NPN TRANSISTOR 2SC5343MG-AT	NQSG2SC5343M
Q2612	NPN TRANSISTOR 2SC5343MG-AT	NQSG2SC5343M
Q2613	NPN TRANSISTOR 2SC5343MG-AT	NQSG2SC5343M
Q2614	NPN TRANSISTOR 2SC5343MG-AT	NQSG2SC5343M
Q2618	NPN TRANSISTOR 2SC5343MG-AT	NQSG2SC5343M
Q2619	NPN TRANSISTOR 2SC5343MG-AT	NQSG2SC5343M
Q2620	NPN TRANSISTOR 2SC5343MG-AT	NQSG2SC5343M
Q2621	NPN TRANSISTOR 2SC5343MG-AT	NQSG2SC5343M
RESISTORS		
R1004	CARBON RES. 1/4W J 75k Ω	RCX4JATZ0753
R1005	CARBON RES. 1/4W J 33 Ω	RCX4JATZ0330
R1006	CARBON RES. 1/4W J 100k Ω	RCX4JATZ0104
R1008	CARBON RES. 1/4W J 56 Ω	RCX4JATZ0560
R1009	CARBON RES. 1/4W J 100 Ω	RCX4JATZ0101
R1011	CARBON RES. 1/4W J 10 Ω	RCX4JATZ0100
R1012	CARBON RES. 1/4W J 4.7k Ω	RCX4JATZ0472
R1013	METAL OXIDE FILM RES. 2W J 47k Ω	RN02473ZU001
R1014	METAL OXIDE FILM RES. 2W J 0.68 Ω	RN02R68ZU001
R1015	CHIP RES. 1/10W J 1 Ω	RRXAJR5Z01R0
R1016	CHIP RES. 1/10W J 470 Ω	RRXAJR5Z0471
R1017	CHIP RES. 1/10W J 22k Ω	RRXAJR5Z0223
R1018	CHIP RES. 1/10W J 1 Ω	RRXAJR5Z01R0
R1019	CHIP RES. 1/10W J 680 Ω	RRXAJR5Z0681
R1020	CHIP RES. 1/10W F 2k Ω	RRXAFR5H2001
R1021	CARBON RES. 1/4W J 10k Ω	RCX4JATZ0103
R1022	CARBON RES. 1/4W J 10k Ω	RCX4JATZ0103
R1023	CARBON RES. 1/4W J 5.1k Ω	RCX4JATZ0512
R1024	CHIP RES. 1/10W F 270 Ω	RRXAFR5H2700
R1025	CHIP RES. 1/10W F 1.0k Ω	RRXAFR5H1001
R1026	CHIP RES. 1/10W F 1.0k Ω	RRXAFR5H1001
R1027	CARBON RES. 1/4W J 10k Ω	RCX4JATZ0103
R1039	CHIP RES. 1/10W J 1k Ω	RRXAJR5Z0102
R1040	CARBON RES. 1/4W J 100 Ω	RCX4JATZ0101
R1041	PCB JUMPER D0.6-P5.0	JW5.0T
R1046	CHIP RES. 1/10W F 1.5k Ω	RRXAFR5H1501
R1047	CHIP RES. 1/10W F 100 Ω	RRXAFR5H1000
R1048	CHIP RES. 1/10W F 4.7k Ω	RRXAFR5H4701
R1142	CHIP RES. 1/10W J 1 Ω	RRXAJR5Z01R0
R1143	CHIP RES. 1/10W F 18k Ω	RRXAFR5H1802
R1144	CHIP RES. 1/10W F 10k Ω	RRXAFR5H1002
R1145	CHIP RES. 1/10W J 330k Ω	RRXAJR5Z0334
R2000	CHIP RES. 1/10W J 1k Ω	RRXAJR5Z0102
R2001	CHIP RES. 1/10W J 100 Ω	RRXAJR5Z0101
R2002	CHIP RES. 1/10W J 100 Ω	RRXAJR5Z0101
R2004	CHIP RES. 1/10W J 470 Ω	RRXAJR5Z0471
R2005	CHIP RES.(1608) 1/10W 0 Ω	RRXAZR5Z0000
R2006	CHIP RES. 1/10W J 100 Ω	RRXAJR5Z0101
R2007	CHIP RES. 1/10W J 100 Ω	RRXAJR5Z0101
R2008	CHIP RES. 1/10W J 47k Ω	RRXAJR5Z0473
R2018	CHIP RES. 1/10W J 39k Ω	RRXAJR5Z0393
R2019	CHIP RES. 1/10W J 22k Ω	RRXAJR5Z0223
R2020	CHIP RES. 1/10W J 100 Ω	RRXAJR5Z0101
R2024	CHIP RES. 1/10W J 10k Ω	RRXAJR5Z0103
R2025	CHIP RES. 1/10W J 10k Ω	RRXAJR5Z0103
R2028	CHIP RES. 1/10W J 10k Ω	RRXAJR5Z0103
R2029	CHIP RES. 1/10W J 10k Ω	RRXAJR5Z0103
R2031	CHIP RES. 1/10W J 100 Ω	RRXAJR5Z0101
R2032	CHIP RES. 1/10W J 100 Ω	RRXAJR5Z0101
R2033	CHIP RES. 1/10W J 100 Ω	RRXAJR5Z0101
R2034	CHIP RES.(1608) 1/10W 0 Ω	RRXAZR5Z0000
R2035	CHIP RES. 1/10W J 10k Ω	RRXAJR5Z0103
R2039	CHIP RES. 1/10W J 680 Ω	RRXAJR5Z0681

Ref. No.	Description	Part No.
R2050	CHIP RES. 1/10W J 10k Ω	RRXAJR5Z0103
R2051	CHIP RES. 1/10W J 1k Ω	RRXAJR5Z0102
R2053	CHIP RES. 1/10W J 47k Ω	RRXAJR5Z0473
R2056	CHIP RES. 1/10W J 10k Ω	RRXAJR5Z0103
R2058	CHIP RES. 1/10W J 10k Ω	RRXAJR5Z0103
R2060	CHIP RES. 1/10W J 47k Ω	RRXAJR5Z0473
R2061	CHIP RES. 1/10W J 5.6k Ω	RRXAJR5Z0562
R2063	CARBON RES. 1/4W J 620 Ω	RCX4JATZ0621
R2064	CARBON RES. 1/4W J 620 Ω	RCX4JATZ0621
R2065	CARBON RES. 1/4W J 10 Ω	RCX4JATZ0100
R2066	CHIP RES. 1/10W J 47k Ω	RRXAJR5Z0473
R2067	CHIP RES. 1/10W J 5.6k Ω	RRXAJR5Z0562
R2069	CARBON RES. 1/4W J 120 Ω	RCX4JATZ0121
R2070	CARBON RES. 1/4W J 120 Ω	RCX4JATZ0121
R2073	CARBON RES. 1/4W J 620 Ω	RCX4JATZ0621
R2074	CARBON RES. 1/4W J 620 Ω	RCX4JATZ0621
R2091	CARBON RES. 1/4W J 47k Ω	RCX4JATZ0473
R2092	CARBON RES. 1/4W J 47k Ω	RCX4JATZ0473
R2093	CHIP RES. 1/10W J 10k Ω	RRXAJR5Z0103
R2094	CHIP RES. 1/10W J 47k Ω	RRXAJR5Z0473
R2095	CHIP RES. 1/10W J 3.9k Ω	RRXAJR5Z0392
R2100	CHIP RES. 1/10W J 2k Ω	RRXAJR5Z0202
R2101	CHIP RES. 1/10W J 2.2k Ω	RRXAJR5Z0222
R2102	CHIP RES. 1/10W J 2.2k Ω	RRXAJR5Z0222
R2103	CHIP RES. 1/10W J 220 Ω	RRXAJR5Z0221
R2104	CHIP RES. 1/10W J 75 Ω	RRXAJR5Z0750
R2105	CHIP RES. 1/10W J 100k Ω	RRXAJR5Z0104
R2109	CHIP RES.(1608) 1/10W 0 Ω	RRXAZR5Z0000
R2115	CARBON RES. 1/4W J 5.6 Ω	RCX4JATZ05R6
R2116	CARBON RES. 1/4W J 5.6 Ω	RCX4JATZ05R6
R2117	CHIP RES. 1/10W J 1k Ω	RRXAJR5Z0102
R2118	CARBON RES. 1/4W J 10 Ω	RCX4JATZ0100
R2208	CHIP RES. 1/10W F 24k Ω	RRXAFR5H2402
R2209	CHIP RES. 1/10W F 24k Ω	RRXAFR5H2402
R2210	CHIP RES. 1/10W J 8.2k Ω	RRXAJR5Z0822
R2211	CHIP RES. 1/10W J 8.2k Ω	RRXAJR5Z0822
R2212	CHIP RES. 1/10W F 33.0k Ω	RRXAFR5H3302
R2213	CHIP RES. 1/10W F 33.0k Ω	RRXAFR5H3302
R2214	CHIP RES. 1/10W J 100k Ω	RRXAJR5Z0104
R2215	CHIP RES. 1/10W J 100k Ω	RRXAJR5Z0104
R2216	CHIP RES. 1/10W J 820 Ω	RRXAJR5Z0821
R2217	CHIP RES. 1/10W J 1k Ω	RRXAJR5Z0102
R2218	CHIP RES. 1/10W J 820 Ω	RRXAJR5Z0821
R2219	CHIP RES. 1/10W J 1k Ω	RRXAJR5Z0102
R2220	CHIP RES. 1/10W J 100k Ω	RRXAJR5Z0104
R2221	CHIP RES. 1/10W J 100k Ω	RRXAJR5Z0104
R2223	CHIP RES. 1/10W J 4.7k Ω	RRXAJR5Z0472
R2224	CHIP RES. 1/10W J 2.2k Ω	RRXAJR5Z0222
R2226	CHIP RES. 1/10W J 1k Ω	RRXAJR5Z0102
R2227	CHIP RES. 1/10W J 220 Ω	RRXAJR5Z0221
R2228	CHIP RES. 1/10W J 220 Ω	RRXAJR5Z0221
R2229	CHIP RES. 1/10W J 2.2k Ω	RRXAJR5Z0222
R2230	CHIP RES. 1/10W J 4.7k Ω	RRXAJR5Z0472
R2284	CHIP RES. 1/10W J 10 Ω	RRXAJR5Z0100
R2285	CHIP RES. 1/10W J 10k Ω	RRXAJR5Z0103
R2286	CHIP RES. 1/10W J 10k Ω	RRXAJR5Z0103
R2287	CHIP RES. 1/10W J 10k Ω	RRXAJR5Z0103
R2288	CHIP RES. 1/10W J 1.8k Ω	RRXAJR5Z0182
R2301	CHIP RES.(1608) 1/10W F 82.0 Ω	RRXAFR5H82R0
R2302	CHIP RES.(1608) 1/10W F 82.0 Ω	RRXAFR5H82R0
R2303	CHIP RES.(1608) 1/10W F 82.0 Ω	RRXAFR5H82R0
R2304	CHIP RES.(1608) 1/10W F 82.0 Ω	RRXAFR5H82R0
R2305	CHIP RES.(1608) 1/10W F 82.0 Ω	RRXAFR5H82R0

Ref. No.	Description	Part No.
R2307	CHIP RES.(1608) 1/10W 0 Ω	RRXAZR5Z0000
R2309	CHIP RES. 1/10W J 10k Ω	RRXAJR5Z0103
R2310	CHIP RES. 1/10W J 75 Ω	RRXAJR5Z0750
R2311	CHIP RES. 1/10W J 75 Ω	RRXAJR5Z0750
R2312	CHIP RES. 1/10W J 75 Ω	RRXAJR5Z0750
R2313	CHIP RES. 1/10W J 75 Ω	RRXAJR5Z0750
R2315	CHIP RES. 1/10W J 27k Ω	RRXAJR5Z0273
R2325	CHIP RES.(1608) 1/10W 0 Ω	RRXAZR5Z0000
R2341	CHIP RES. 1/10W F 4.7k Ω	RRXAFR5H4701
R2342	CHIP RES. 1/10W F 2.7k Ω	RRXAFR5H2701
R2343	CHIP RES. 1/10W F 1.5k Ω	RRXAFR5H1501
R2344	CHIP RES. 1/10W F 1.2k Ω	RRXAFR5H1201
R2345	CHIP RES. 1/10W F 1.2k Ω	RRXAFR5H1201
R2600	CHIP RES. 1/10W J 4.7k Ω	RRXAJR5Z0472
R2601	CHIP RES. 1/10W J 4.7k Ω	RRXAJR5Z0472
R2602	CHIP RES. 1/10W J 2.2k Ω	RRXAJR5Z0222
R2603	CHIP RES. 1/10W J 4.7k Ω	RRXAJR5Z0472
R2604	CARBON RES. 1/4W J 4.7k Ω	RCX4JATZ0472
R2606	CHIP RES. 1/10W J 47k Ω	RRXAJR5Z0473
R2607	CHIP RES. 1/10W J 4.7k Ω	RRXAJR5Z0472
R2608	CHIP RES. 1/10W J 4.7k Ω	RRXAJR5Z0472
R2609	CHIP RES. 1/10W J 4.7k Ω	RRXAJR5Z0472
R2610	CARBON RES. 1/4W J 220 Ω	RCX4JATZ0221
R2612	CHIP RES. 1/10W J 10k Ω	RRXAJR5Z0103
R2613	CHIP RES. 1/10W F 10k Ω	RRXAFR5H1002
R2616	CHIP RES. 1/10W F 15k Ω	RRXAFR5H1502
R2617	CHIP RES. 1/10W F 2k Ω	RRXAFR5H2001
R2620	CHIP RES. 1/10W J 4.7k Ω	RRXAJR5Z0472
R2621	CARBON RES. 1/4W J 82 Ω	RCX4JATZ0820
R2622	CARBON RES. 1/4W J 82 Ω	RCX4JATZ0820
R2636	CARBON RES. 1/4W J 33 Ω	RCX4JATZ0330
R2637	METAL OXIDE FILM RES. 1W J 1.2 Ω	RN011R2ZU001
R2638	CHIP RES. 1/10W J 10k Ω	RRXAJR5Z0103
R2639	CHIP RES. 1/10W J 10k Ω	RRXAJR5Z0103
R2650	CHIP RES. 1/10W J 1k Ω	RRXAJR5Z0102
R2651	CHIP RES. 1/10W J 10k Ω	RRXAJR5Z0103
R2652	CHIP RES. 1/10W J 1k Ω	RRXAJR5Z0102
R2653	CHIP RES. 1/10W J 10k Ω	RRXAJR5Z0103
R2654	CHIP RES. 1/10W J 5.1k Ω	RRXAJR5Z0512
R2655	CHIP RES. 1/10W J 8.2k Ω	RRXAJR5Z0822
R2656	CHIP RES. 1/10W J 1k Ω	RRXAJR5Z0102
R2657	CHIP RES. 1/10W J 2.7k Ω	RRXAJR5Z0272
R2658	CHIP RES. 1/10W J 1k Ω	RRXAJR5Z0102
R2659	CHIP RES.(1608) 1/10W 0 Ω	RRXAZR5Z0000
R2660	CHIP RES. 1/10W F 1.5k Ω	RRXAFR5H1501
R2661	CHIP RES. 1/10W F 3.3k Ω	RRXAFR5H3301
R2662	CHIP RES. 1/10W F 1.5k Ω	RRXAFR5H1501
R2663	CHIP RES. 1/10W F 2.2k Ω	RRXAFR5H2201
R2664	CHIP RES. 1/10W F 3.3k Ω	RRXAFR5H3301
R2665	CHIP RES. 1/10W J 100 Ω	RRXAJR5Z0101
R2667	CHIP RES. 1/10W J 330 Ω	RRXAJR5Z0331
R2669	CHIP RES. 1/10W J 27k Ω	RRXAJR5Z0273
R2671	CHIP RES. 1/10W J 220k Ω	RRXAJR5Z0224
R2673	CHIP RES. 1/10W J 2.2M Ω	RRXAJR5Z0225
R2674	CHIP RES. 1/10W J 100k Ω	RRXAJR5Z0104
R2675	CHIP RES. 1/10W J 220 Ω	RRXAJR5Z0221
R2676	CHIP RES. 1/10W J 100k Ω	RRXAJR5Z0104
R2678	CHIP RES.(1608) 1/10W 0 Ω	RRXAZR5Z0000
R2679	CHIP RES. 1/10W J 47k Ω	RRXAJR5Z0473
R2680	CHIP RES. 1/10W J 27k Ω	RRXAJR5Z0273
MISCELLANEOUS		
2L055	SCREW S-TIGHT M3X8 BIND HEAD+	GBJS3080

Ref. No.	Description	Part No.
AC1001▲	AC CORD W/O A GND WIRE UL/CSA/1700/NO/BLACK	WAC1720LW001
B47	HEAT SINK E2A00JD	1VM424636E
F1001▲	FUSE TIME RAG FSL 250V 2A(EM)	PDGJAB0NG202
FH1001	FUSE HOLDER MSF-015 LF (B110)	XH01Z00LY002
FH1002	FUSE HOLDER MSF-015 LF (B110)	XH01Z00LY002
JK2100	RCA JACK(BLACK) MSP-251V-01 NI FE LF	JXRL010LY125
JK2200	PIN JACK 3P MSD-243V-48 NI FE LF	JXRL030LY167
JK2300	RCA JACK 3PIN MSD-243V-18 NI FE LF	JXRL030LY132
JK2400	FIBER OPTIC TRANS.MODULE OC-0805T*002	JWHHA00JD002
JP2201	PCB JUMPER D0.6-P7.0	JW7.0T
JP2204	PCB JUMPER D0.6-P25.0	JW25.0T
JP2208	PCB JUMPER D0.6-P8.5	JW8.5T
JP2209	PCB JUMPER D0.6-P24.0	JW24.0T
JP2210	PCB JUMPER D0.6-P28.0	JW28.0T
JP2211	PCB JUMPER D0.6-P13.0	JW13.0T
JP2213	PCB JUMPER D0.6-P13.0	JW13.0T
JP2215	PCB JUMPER D0.6-P8.0	JW8.0T
JP2216	PCB JUMPER D0.6-P5.0	JW5.0T
JP2217	PCB JUMPER D0.6-P5.0	JW5.0T
JP2219	PCB JUMPER D0.6-P15.0	JW15.0T
JP2222	PCB JUMPER D0.6-P27.5	JW27.5T
JP2225	PCB JUMPER D0.6-P25.0	JW25.0T
JP2226	PCB JUMPER D0.6-P13.0	JW13.0T
JP2227	PCB JUMPER D0.6-P10.5	JW10.5T
JP2228	PCB JUMPER D0.6-P17.0	JW17.0T
JP2229	PCB JUMPER D0.6-P5.0	JW5.0T
SA1001▲	VARIATOR 10D 471K SVR	NVQZVR10D471
T1001▲	TRANS POWER 8733	LTT2PCOKT050
X2000	CERAMIC RESONATOR ZTT8.00MT47	FY0805PLN004

FRONT ASSEMBLY

Ref. No.	Description	Part No.
	FRONT ASSEMBLY Consists of the following:	1VSA22025
	FRONT CBA POWER SW CBA	-----

FRONT CBA

Ref. No.	Description	Part No.
	FRONT CBA Consists of the following:	-----
CAPACITORS		
C3000	CHIP CERAMIC CAP.(1608) F Z 0.1μF/50V	CHD1JZ30F104
C3001	ELECTROLYTIC CAP. 22μF/50V/MMH7	CEF22RENW025
C3002	CHIP CERAMIC CAP.(1608) F Z 0.1μF/50V	CHD1JZ30F104
C3003	ELECTROLYTIC CAP. 100μF/6.3V/MMH7	CEA101ENW025
C3005	CHIP CERAMIC CAP.(1608) B K 1000pF/50V	CHD1JK30B102
C3006	CHIP CERAMIC CAP.(1608) F Z 0.1μF/50V	CHD1JZ30F104
C3007	ELECTROLYTIC CAP. 100μF/6.3V/MMH7	CEA101ENW025
C3008	CHIP CERAMIC CAP.(1608) B K 0.1μF/50V	CHD1JK30B104
CONNECTORS		
CN3000	WIRE ASSEMBLY FRONT-AV 16P WX1E5K10-002	WX1E5K10-002
CN3001	CONNECTOR PRINT OSU S3B-PH-K-S(LF)(SN)	J3PHC03JG030
COIL		
L3001	CHIP INDUCTOR LB 2016T101K	LLC101KTU007
TRANSISTOR		
Q3000	NPN TRANSISTOR SMD 2SC5343SFG	NQ1G2SC5343S
RESISTORS		
R3000	CHIP RES. 1/10W J 10 Ω	RRXAJR5Z0100

Ref. No.	Description	Part No.
R3001	CHIP RES. 1/10W J 10 Ω	RRXAJR5Z0100
R3002	CHIP RES. 1/10W J 12k Ω	RRXAJR5Z0123
R3003	CHIP RES.(1608) 1/10W 0 Ω	RRXAZR5Z0000
R3004	CHIP RES. 1/10W J 1k Ω	RRXAJR5Z0102
R3005	CHIP RES. 1/10W J 150 Ω	RRXAJR5Z0151
R3012	CHIP RES. 1/10W J 180 Ω	RRXAJR5Z0181
R3014	CHIP RES. 1/10W J 6.8k Ω	RRXAJR5Z0682
R3015	CHIP RES. 1/10W J 220 Ω	RRXAJR5Z0221
R3019	CHIP RES. 1/10W J 330 Ω	RRXAJR5Z0331
R3020	CHIP RES. 1/10W J 5.1k Ω	RRXAJR5Z0512
SWITCHES		
SW3003	TACT SWITCH SKQSAB	SST0101AL038
SW3004	TACT SWITCH SKQSAB	SST0101AL038
SW3005	TACT SWITCH SKQSAB	SST0101AL038
SW3006	TACT SWITCH SKQSAB	SST0101AL038
MISCELLANEOUS		
B70	TAPE HIMERON(60*6) HG470ED	1VM421170
FL3000	FL DM182-GINK	TVFD150FT018
RS3000	PHOTO LINK MODULE KSM-713TH2P	USESJR5K061

POWER SW CBA

Ref. No.	Description	Part No.
	POWER SW CBA Consists of the following:	-----
DIODE		
D3007	LED(RED) LTL-1CHEE	NPQZLTL1CHEE
SWITCH		
SW3007	TACT SWITCH SKQSAB	SST0101AL038
MISCELLANEOUS		
WX3000	WIRE ASSEMBLY FRONT-SWITCH 3P WIRE WX1E5K50-001	WX1E5K50-001

SD ASSEMBLY

Ref. No.	Description	Part No.
	SD ASSEMBLY Consists of the following:	1VSA20906
	SD-A CBA	-----
	SD-B CBA	-----
	SD-C CBA	-----

SD-A CBA

Ref. No.	Description	Part No.
	SD-A CBA Consists of the following:	-----
CAPACITOR		
C4008	CHIP CERAMIC CAP,(1608) CH J 33pF/50V	CHD1JJ3CH330
CONNECTORS		
CN4001	B TO B CONNECTOR 16P SOKET 131101116K2	J313160TG001
CN4003	242 SERIES CONNECTOR TUC-P15X-B1 WHT ST	JCTUB15TG002
COILS		
L4002	CHIP INDUCTOR LK160882NM-T	LLACMB3TU82N
L4008	CHIP RES.(1608) 1/10W 0 Ω	RRXAZR5Z0000
RESISTORS		
R4001	CHIP RES. 1/10W J 47 Ω	RRXAJR5Z0470
R4002	CHIP RES. 1/10W J 47 Ω	RRXAJR5Z0470
R4003	CHIP RES. 1/10W J 47 Ω	RRXAJR5Z0470
R4004	CHIP RES. 1/10W J 22 Ω	RRXAJR5Z0220
R4005	CHIP RES. 1/10W J 47 Ω	RRXAJR5Z0470
R4006	CHIP RES. 1/10W J 47 Ω	RRXAJR5Z0470

SD-B CBA

Ref. No.	Description	Part No.
	SD-B CBA Consists of the following:	-----
CONNECTORS		
CN4101	242 SERIES CONNECTOR 224202115W1	J322C15TG001
CN4102	242 SERIES CONNECTOR 224202115W1	J322C15TG001

SD-C CBA

Ref. No.	Description	Part No.
	SD-C CBA Consists of the following:	-----
CAPACITORS		
C4001	CHIP CERAMIC CAP,(1608) B K 0.1μF/16V	CHD1CK30B104
C4002	CHIP CERAMIC CAP,(2125) B K 10μF/6.3V	CHE0KK30B106
CONNECTORS		
CN4002	CONNECTOR IC CARD MES 9PIN 1939115-1	JF18090AP001
CN4004	242 SERIES CONNECTOR TUC-P15X-B1 WHT ST	JCTUB15TG002
RESISTOR		
R4022	CHIP RES.(1608) 1/10W 0 Ω	RRXAZR5Z0000

ONKYO CORPORATION

Service Dept. Technical Support : 2-1, Nisshin-cho, Neyagawa-shi, OSAKA 572-8540, JAPAN
Tel: 072-831-8023 Fax: 072-831-8163

ONKYO U.S.A. CORPORATION

18 Park Way, Upper Saddle River, N.J. 07458, U.S.A.
Tel: 201-785-2600 Fax: 201-785-2650 <http://www.us.onkyo.com/>

ONKYO EUROPE ELECTRONICS GmbH (DUISBURG OFFICE)

Hafennr.7602, Logport Office-Center, Bliersheimerstr.80B, 47229 Duisburg, Germany
Tel: +49-2065-90198-00 Fax: +49-2065-90198-40 <http://www.eu.onkyo.com/>

ONKYO EUROPE UK Office

Suite 1, Gregories Court, Gregories Road, Beaconsfield, Buckinghamshire, HP9 1HQ
UNITED KINGDOM Tel: +44-(0)1494-681515 Fax: +44(0)-1494-680452

ONKYO CHINA LIMITED

Units 2102-2107, Metroplaza Tower I, 223 Hing Fong Road, Kwai Chung,
N.T., HONG KONG Tel: 852-2429-3118 Fax: 852-2428-9039
<http://www.ch.onkyo.com/>

