

# ONKYO SERVICE MANUAL

## DVD Changer MODEL DV-C503

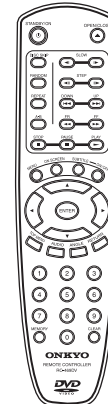
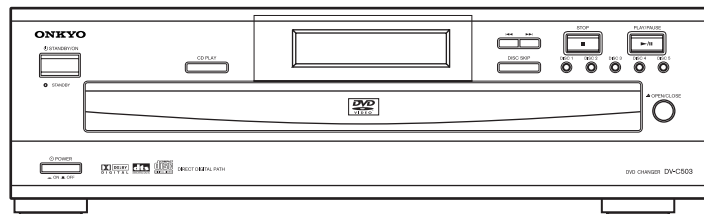

RC-469DV

### Black model

BUDD	120V AC, 60Hz
------	---------------

### SAFETY-RELATED COMPONENT WARNING!!

THE MARK  FOUND ON SOME COMPONENT PARTS INDICATES THE CRITICAL FOR RISK OF FIRE AND ELECTRIC SHOCK.

WHEN REPLACING, BE SURE TO USE PARTS OF IDENTICAL DESIGNATION.

MAKE LEAKAGE-CURRENT OR RESISTANCE MEASUREMENTS TO DETERMINE THAT EXPOSED PARTS ARE ACCEPTABLY INSULATED FROM THE SUPPLY CIRCUIT BEFORE RETURNING THE APPLIANCE TO THE CUSTOMER.

## SPECIFICATIONS

### DVD Changer

---

Power supply	AC 120 V, 60 Hz
Power consumption	20 W
Weight	15.0 lbs
External dimensions	17 1/8" x 5 1/16" x 16 15/16" (W/H/D)
Signal system	NTSC
Frequency range (digital audio)	48 kHz sampling 4 Hz to 22 kHz 96 kHz sampling 4 Hz to 42 kHz
Signal-to-noise ratio (digital audio)	More than 98 dB
Audio dynamic range (digital audio)	More than 95 dB
Harmonic distortion (digital audio)	Less than 0.005 %
Wow and flutter	Below measurable level
Operating conditions	Temperature: 5°C to 35°C (41°F to 95°F), Operation status: Horizontal

### Outputs

---

Video output	1.0 V (p-p), 75 ohm, negative sync., pin jack × 1
S-video output	(Y) 1.0 V (p-p), 75 ohm, negative sync. (C) 0.286 V (p-p), 75 ohm, Mini DIN 4-pin × 1
Component video output	(Y) 1.0 V (p-p), 75 ohm, negative sync., pin jack × 1 (PB)/(PR) 0.7 V (p-p), 75 ohm, pin jack × 2
Audio output (digital output Optical)	Optical connector × 1
Audio output (digital output Coaxial)	0.5 V (p-p), 75 ohm, pin jack × 1
Audio output (analog output)	2.0 V (rms), 320 ohm, pin jack (L, R) × 2

### Supplied Accessories

---

Audio/video connection cable	1
Remote controller (RC-469DV)	1
Batteries (size AAA/R3)	2

Specifications and features are subject to change without notice.

## SERVICE NOTE

### PRECAUTIONS

1. Ground for the work-desk.

Place a conductive sheet such as a sheet of copper (with impedance lower than 10Mohm) on the work-desk and place the set on the conductive sheet so that the chassis.

2. Grounding for the test equipments and tools.

Test equipments and toolings should be grounded in order that their ground level is the same the ground of the power source.

3. Grounding for the human body.

Be sure to put on a wrist-strap for grounding whose other end is grounded.

Be particularly careful when the workers wear synthetic fiber clothes, or air is dry.

4. Select a soldering iron that permits no leakage and have the tip of the iron well-grounded.

5. Do not check the laser diode terminals with the probe of a circuit tester or oscilloscope.

#### 1. Replacing the fuses

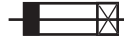
 This symbol located near the fuse indicates that the fuse used is show operating type, For continued protection against fire hazard, replace with same type fuse , For fuse rating, refer to the marking adjust to the symbol.

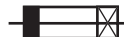
 Ce symbole indique que le fusible utilise est e lent. Pour une protection permanente, n'utiliser que des fusibles de meme type. Ce demier est indique la qu le present symbol est appose.

#### 2. Safety-check out

(Only U.S.A. model)

After correcting the original service problem perform the following safety check before releasing the set to the customer  
Connect the insulating-resistance tester between the plug of power supply cord and terminal GND on the back panel.

Specifications: More than 10M ohm at 500V

REF.NO.	PART NO.	DESCRIPTION
F1	252159 	2A-UL/T-237

### LASER CAUTION

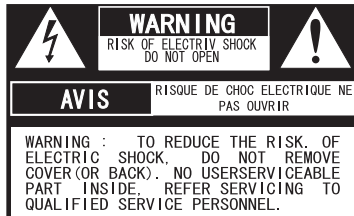

The lightning flash with arrowhead symbol, within an equilateral triangle, is intended to alert the user to the presence of uninsulated "dangerous voltage" within the product's enclosure that may be of sufficient magnitude to constitute a risk of electric shock to persons.



The exclamation point within an equilateral triangle is intended to alert the user to the presence of important operating and maintenance (servicing) instruction in the literature accompanying the appliance.

**WARNING :** TO REDUCE THE RISK OF FIRE OR ELECTRIC SHOCK, DO NOT EXPOSE THIS APPLIANCE TO RAIN OR MOISTURE. DANGEROUS HIGH VOLTAGES ARE PRESENT INSIDE THE ENCLOSURE. DO NOT OPEN THE CABINET. REFER SERVICING TO QUALIFIED PERSONNEL ONLY.

**CAUTION :** TO PREVENT ELECTRIC SHOCK, MATCH WIDE BLADE OF PLUG TO WIDE SLOT, FULLY INSERT.

**ATTENTION :** POUR EVITER LES CHOC ELECTRIQUE, INTRODUIRE LA LAME LA PLUS LARGE DA LA FICHE DANS LA BORNE CORRESPONDANTE DA LA PRISE ET POUSSER JUSQU' AU FOND.

### Initialization of setup

1. Press the "DISC 4" and "CDPLAY" key to the same timing.

The "DISC 4 key is pushed previously.

Then, light off the FL tube.

2. Push the power switch.

# EXPLODE VIEW CHASSIS

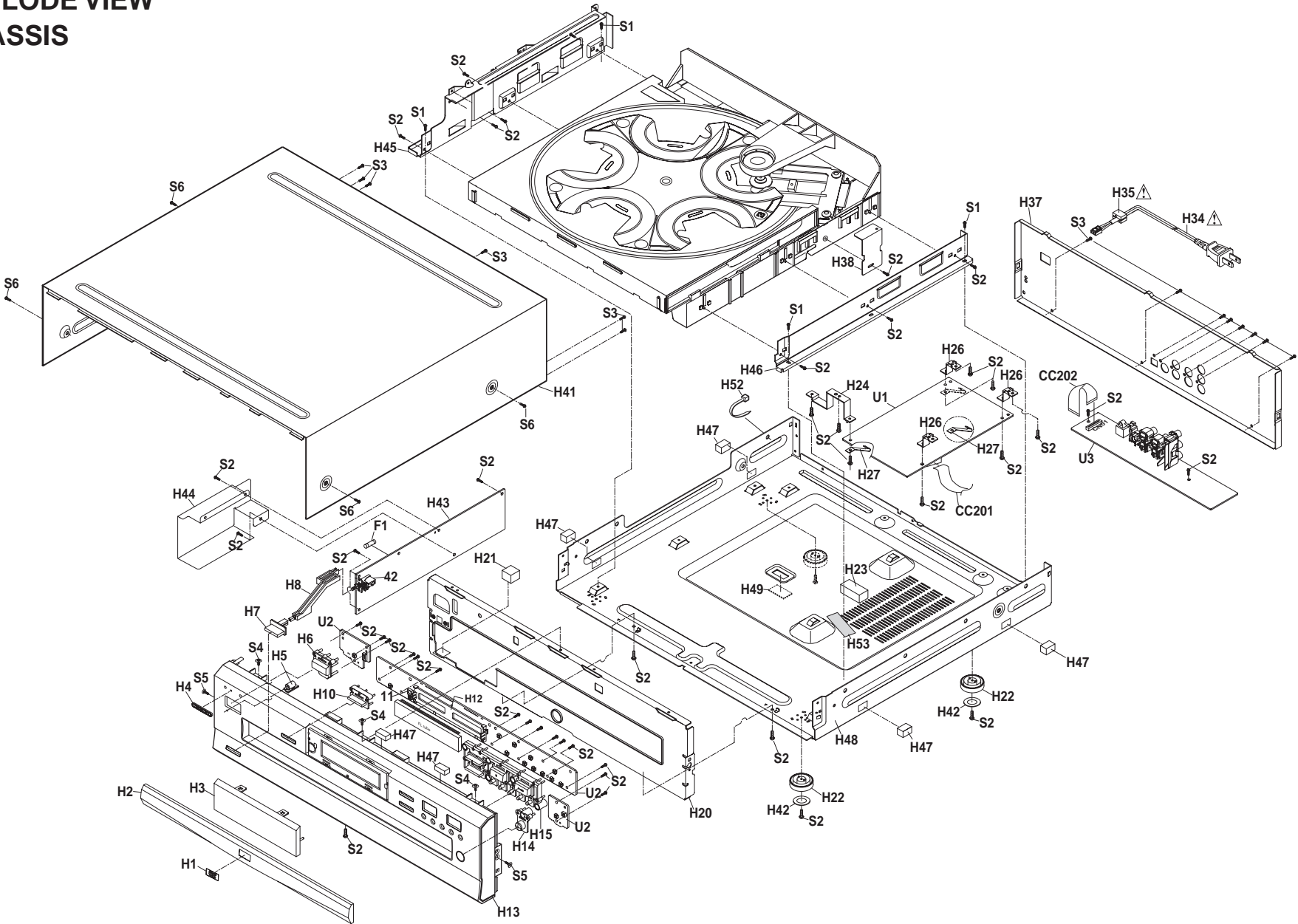

## PARTS LIST

## CHASSIS

REF. NO.	PART NO.	DESCRIPTION	REF. NO.	PART NO.	DESCRIPTION
H1	55221110	Plate, DVD	S1	838130068	3TTB+6B, Self tapping screw
H2	55184480	Drawer panel	S2	838130088	3TTB+8B, Self tapping screw
H3	55221120	Clear plate	S3	838130108	3TTB+10B(BC), Self tapping screw
H4	55186750	Badge Logo	S4	831130088	3TTW+8B, Self tapping screw
H5	55186710	Facet	S6	838440088	4TTB+8B(BC), Self tapping screw
H6	55244650	Button, STANDBY	U1	55183100	Main circuit PC board
H7	55244620	Knob, POWER	U2	55183110	Display PC board, Open/Close SW PC board, Standby LED PC board
H8	55184600	Shaft, power	U3	55183120	Output terminal PC board
H10	55244670	Button, PLAY	F1	△ 252159	2A-UL/T-237, Fuse
H12	55164930	FL holder			
H13	55184330	Front panel			
H14	55244660	Button, OPEN/CLOSE			
H15	55244680	Button, Keys (9-keys)			
H20	55236110	Front chassis			
H21	55201610	Sponge, front bracket			
H22	55125120	Foot (4)			
H23	55196510	Sponge, chassis			
H24	55174580	Bracket ground			
H26	55186640	Bracket main PC board			
H27	55178960	Spring			
H34	△ 55011170	Power cord, 1830mm			
H35	△ 55125180	Cord bushing			
H37	55186610	Rear panel			
H38	55174610	Bracket R small			
H41	55186600	Top cover			
H42	55141370	Rubber (4)			
H42	55127310	Washer foot			
H43	55184690	Power supply board unit			
H44	55221140	Shield cover			
H45	55186670	Bracket L, Frame			
H46	55186680	Bracket R, Frame			
H47	55174550	Cushion, 12 x 8 x 20			
H48	55186620	Main chassis			
H49	55190690	Rubber sheet			
H52	55170390	Wire tie			
H53	55190770	Sheet			

**NOTE: THE COMPONENTS IDENTIFIED BY MARK △ ARE CRITICAL FOR RISK OF FIRE AND ELECTRIC SHOCK. REPLACE ONLY WITH PART NUMBER SPECIFIED.**

EXPLODED VIEW  
ROULETTE MECHANISM

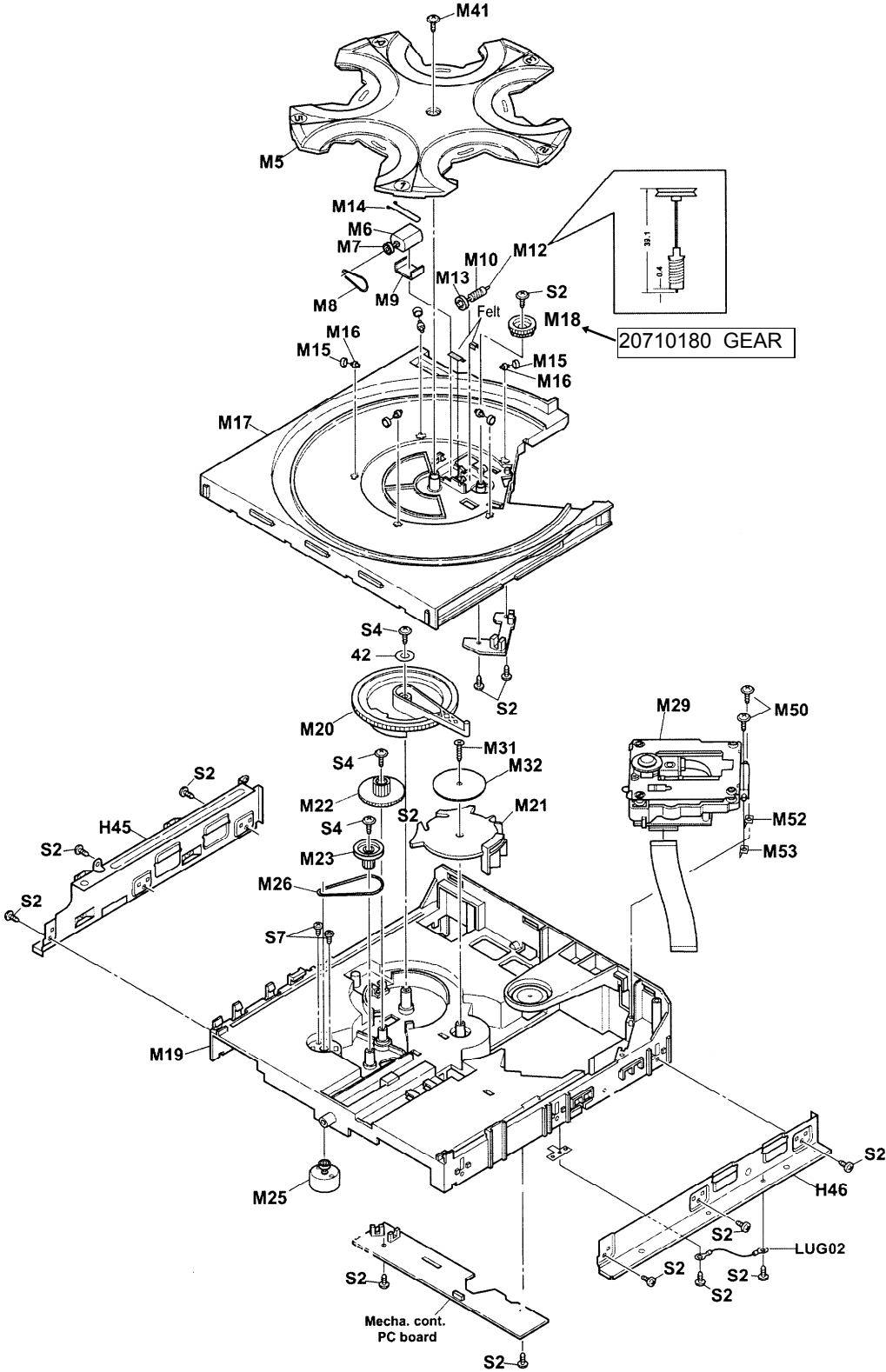

## EXPLODED VIEW PARTS LIST

## ROULETTE MECHANISM

REF. NO.	PART NO.	DESCRIPTION
M5	55020070	Roulette
M6	20581820	Roulette motor
M7	20584560	Pulley
M8	20710160	Rubber belt, Roulette motor
M9	20634190	Felt, 30mm x 2
M10	20710170	Worm gear
M12	20711380	Metal shaft
M13	20711410	Pulley
M14	20712060	Clip
M15	20712120	Rubber roller
M16	20712170	Plastic roller
M17	55020080	Drawer
M18	20710180	GEAR
M19	55020090	Base chassis
M20	55020110	Main gear
M21	20712230	Lift cam
M22	20712240	Drive gear
M23	20712250	Pulley
M25	20581800	Loading motor
M26	20712270	Rubber belt
M29	55186040	DVD mechanism assy
M31	J80200031820	Special screw, 3 x 18
M32	J60300048000	Washer, 55mm t=1mm
M41	20366370	Special screw with washer
M50	20349380	Special screw
M52	55232980	Spring L
M53	55232990	Spring R
LUG02	55184700	Climp AS, 190mm UL1007 PVC
S2	838130088	3TTB+8B, Self tapping screw
S4	831130108	3TTW+10B, Self tapping screw
S7	82112604	2.6+4FN, Pan head screw

BLOCK DIAGRAM

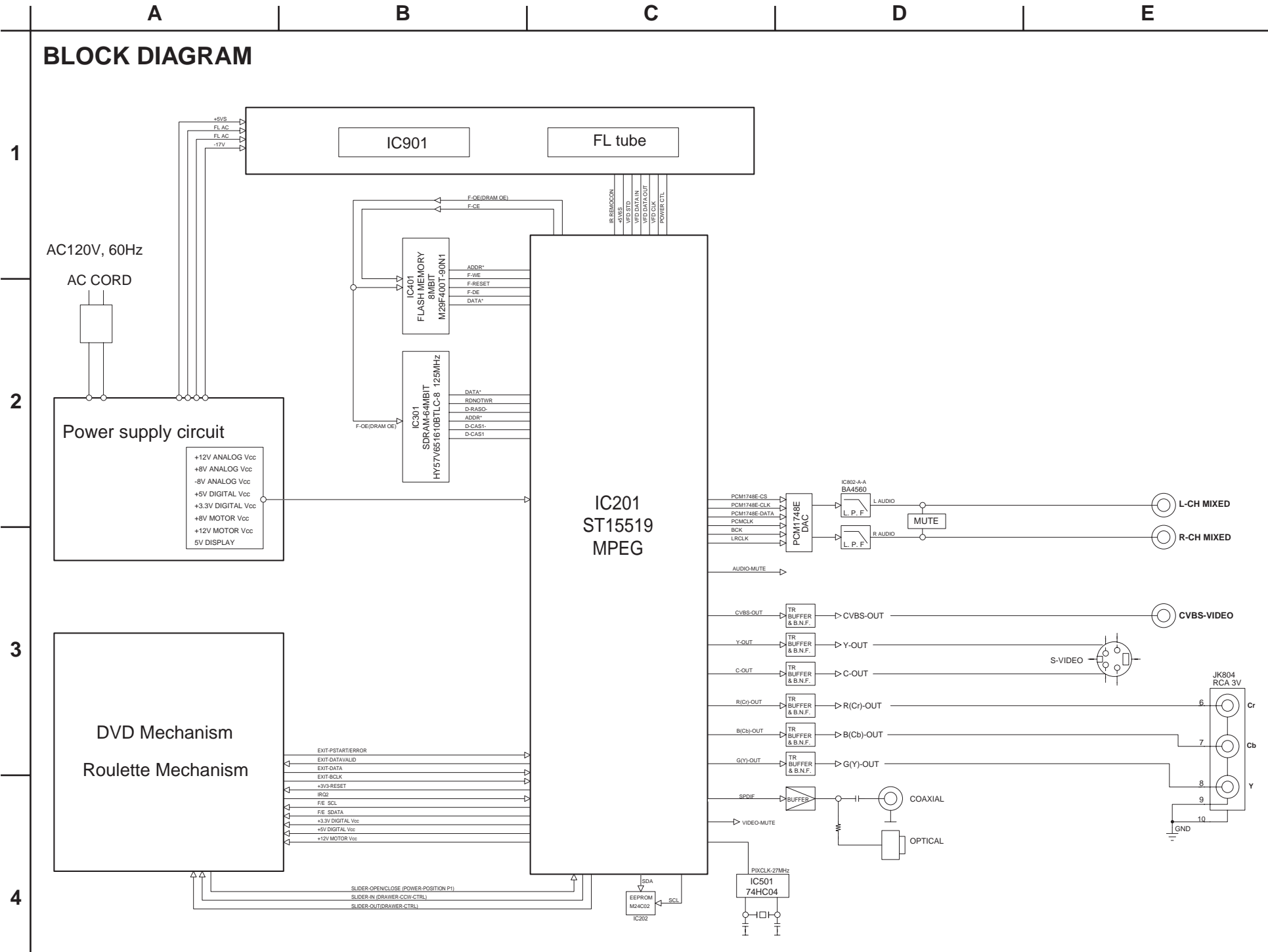



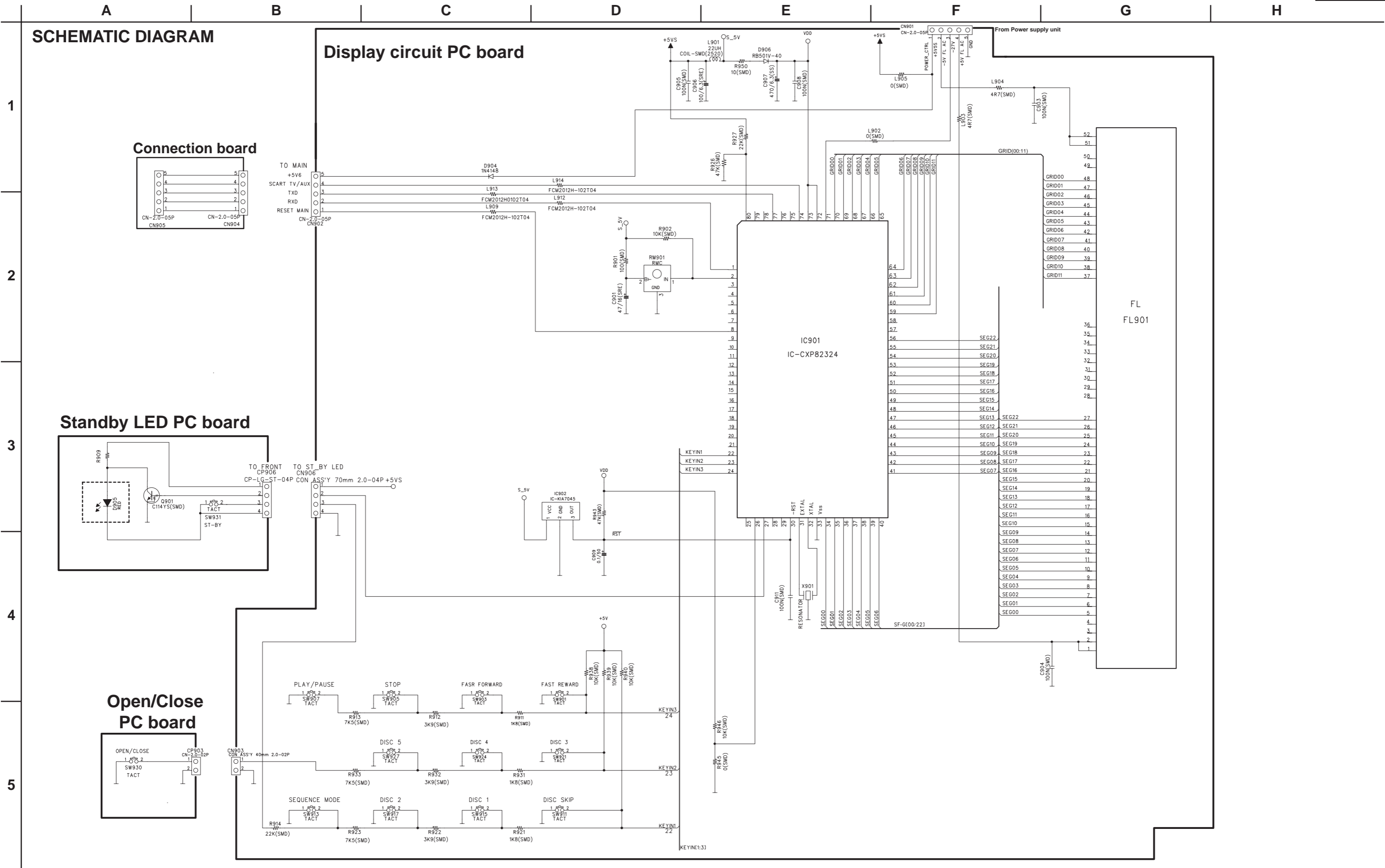

A

B

C

D

E

# SCHEMATIC DIAGRAM

## Output terminal PC board

1

2

3

4

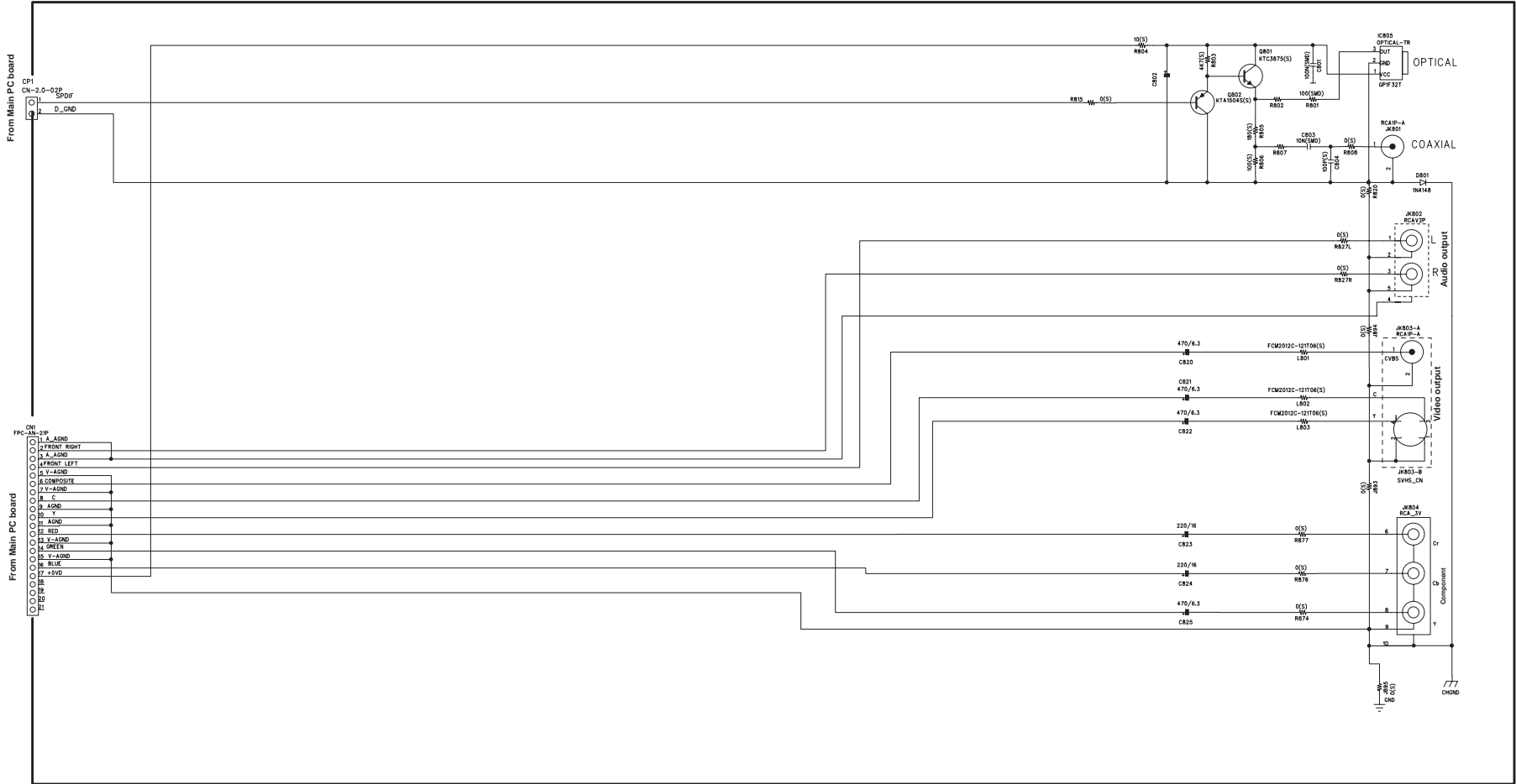

Main circuit PC board

SCHEMATIC DIAGRAM

1

2

3

4

5

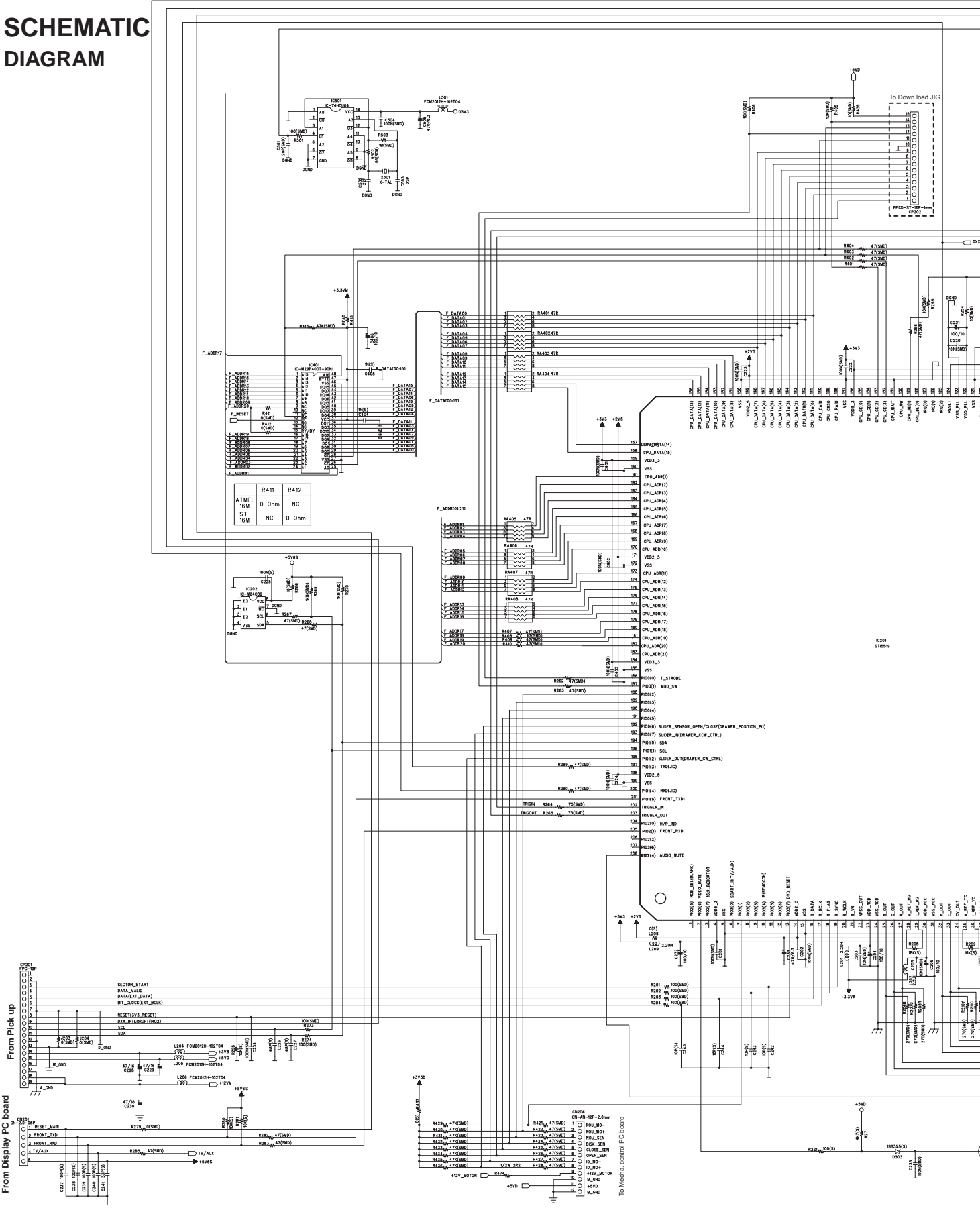

From Pick up  
From Display PC board

To Mecha control PC board

A B C D

SCHEMATIC DIAGRAM

1

2

3

4

5

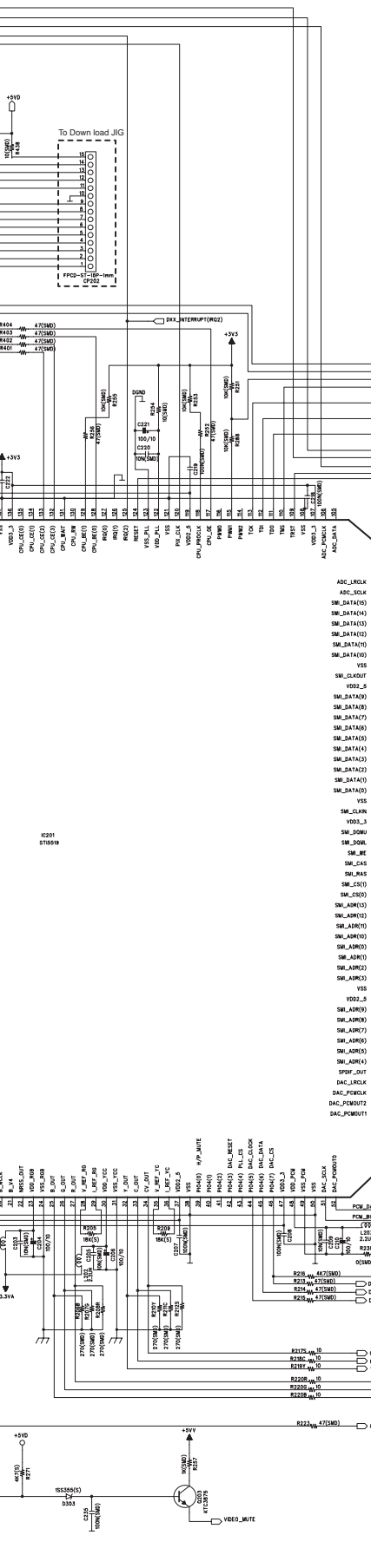
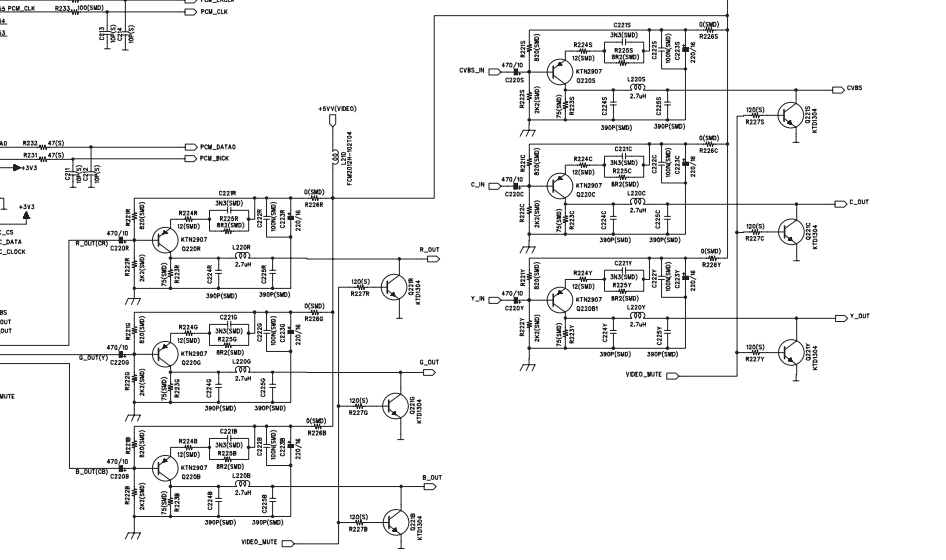
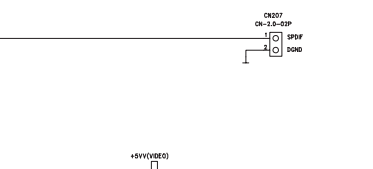
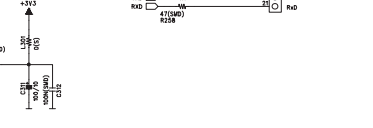
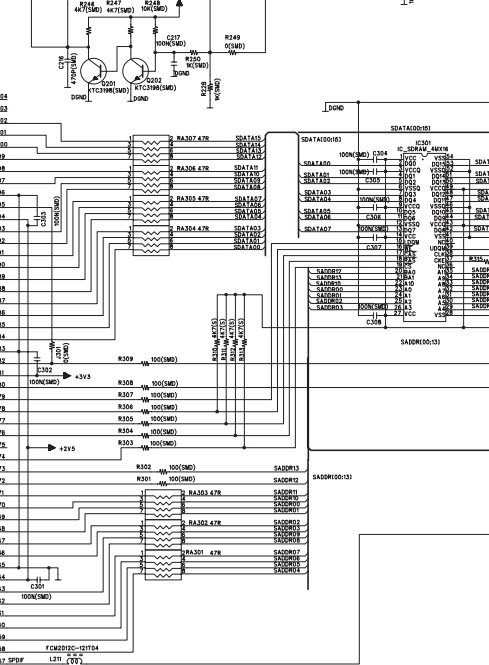
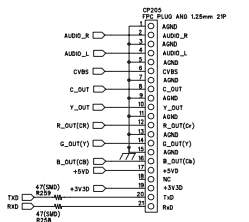
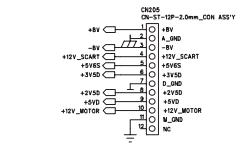
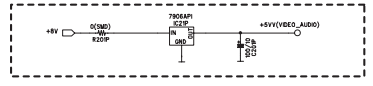
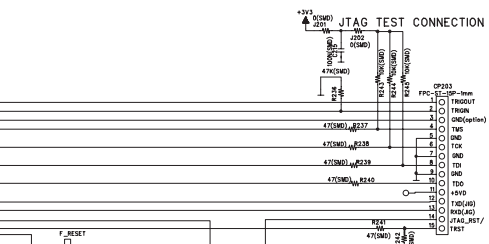
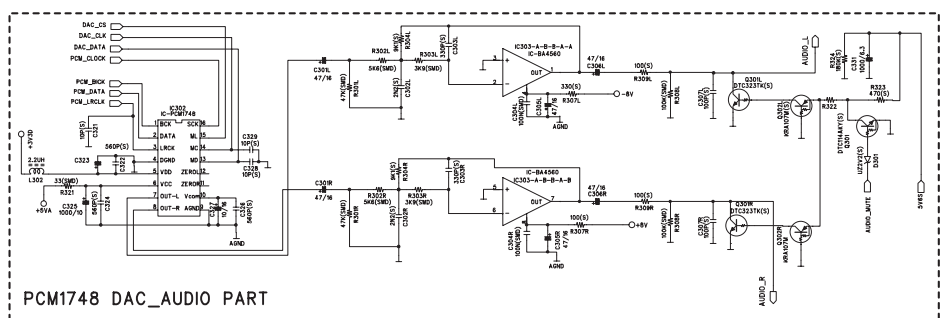



A

B

C

D

E

# SCHEMATIC DIAGRAM

## Output terminal PC board

1

2

3

4





## PRINTED CIRCUIT BOARD PARTS LIST

## DISPLAY CIRCUIT PC BOARD ASSY (PART NO. 55183110)

CIRCUIT NO.	PART NO.	DESCRIPTION
		<b>ICs</b>
IC901	55183040NR	CXP82324
IC902	55191090NR	KIA7045
		<b>Transistor</b>
Q901	5513318092	DTC114YKA
		<b>Remote sensor</b>
RM901	55156010NR	NJL63H38
		<b>FL tube</b>
FL901	55183030NR	HNA-12SM17
		<b>Diodes</b>
D904	7043654016	1N4148
D905	55125510NR	LED
D906	5517787088	RB501V-40
		<b>Coils</b>
L901	1403936091	22uH, Chip
L902,L905	1032875091	0 ohm, Chip
L903,L904	2053866091	4.7 ohm, Chip
L909,L912, L913,L914	5512667050	Choke
		<b>Resonator</b>
X901	55126140NR	10MHz
		<b>Socket AS</b>
CN901	55191010NR	
CN902	55182990NR	
CN903	55199600NR	
CN904,CN905	55123320XX	2.0MM 5 MA ST
CN906	55199610NR	
		<b>Socket</b>
CP903	55090070XX	
CP906	55123310XX	
		<b>Capacitors</b>
C901	2034206030	47uF,+/-20%, 16V, Elect
C903-C905, C908,C911	2028804091	0.1uF, +80-0%,Chip
C906	2025205030	100uF,+/-20%, 6.3V, Elect
C907	2026862041	470uF,+/-20%, 6.3V, Elect
C909	2026884030	1uF,+/-20%, 50V, Elect
		<b>Switches</b>
SW901,SW903, SW905,SW907, SW911,SW913, SW915,SW917, SW921,SW924, SW927,SW930, SW931	55145270NR	
		<b>Spring</b>
Finger	55178960XX	Finger type



A

B

C

D

E

PRINTED CIRCUIT BOARD VIEW

1

Display circuit PC board

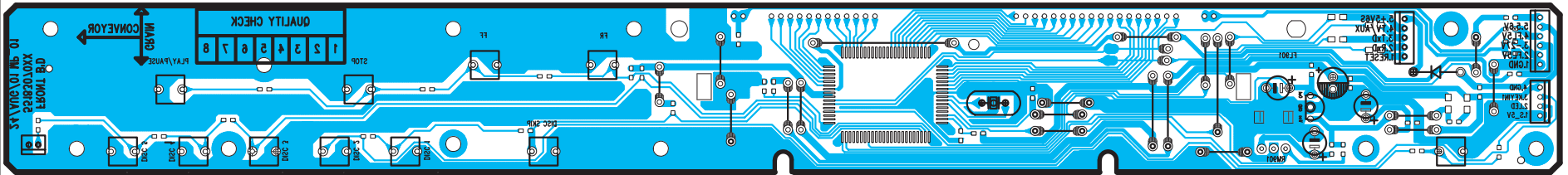

2

Component side view

3

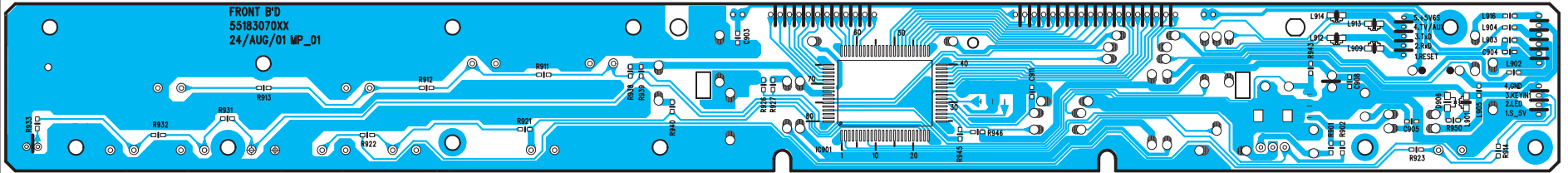

Soldering side view

4



A

B

C

D

E

PRINTED CIRCUIT BOARD VIEW

Main circuit board

Bottom pattern and bottom parts

1

2

3

4

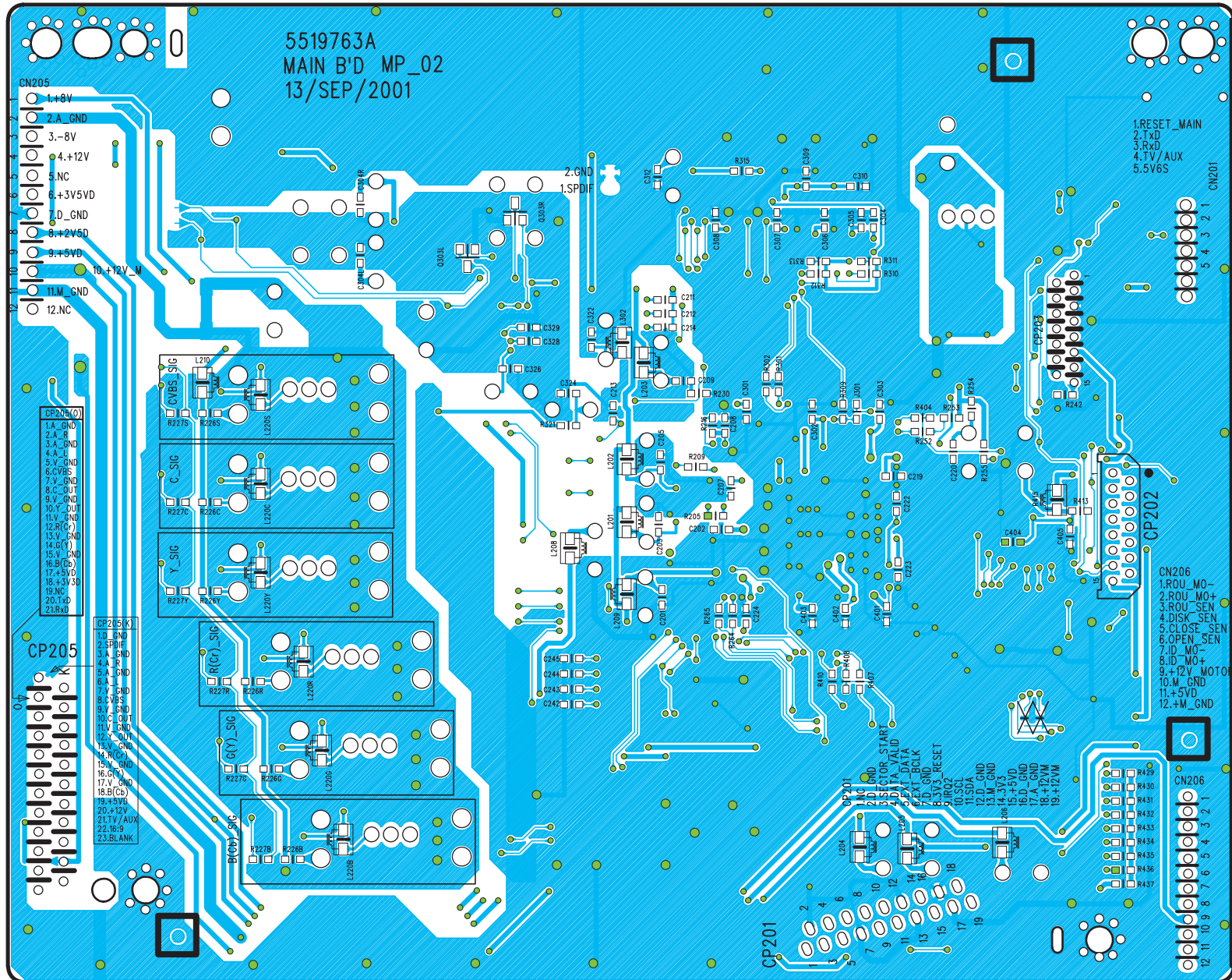

A B C D E

**PRINTED CIRCUIT BOARD VIEW**

**Output terminal PC board**

1

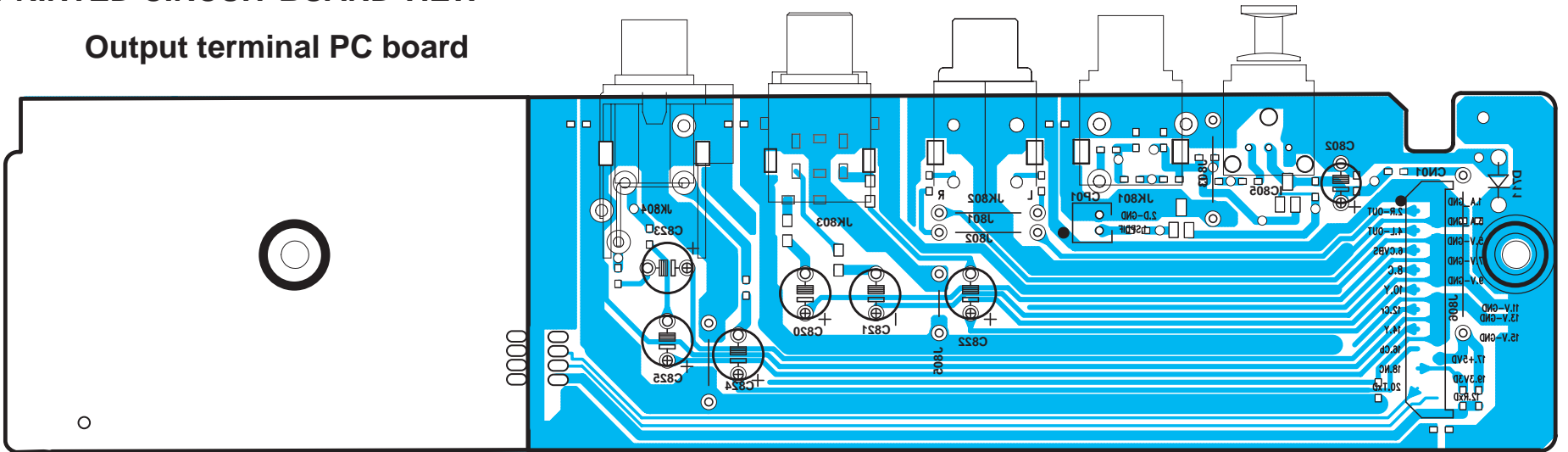

**Component side view**

2

3

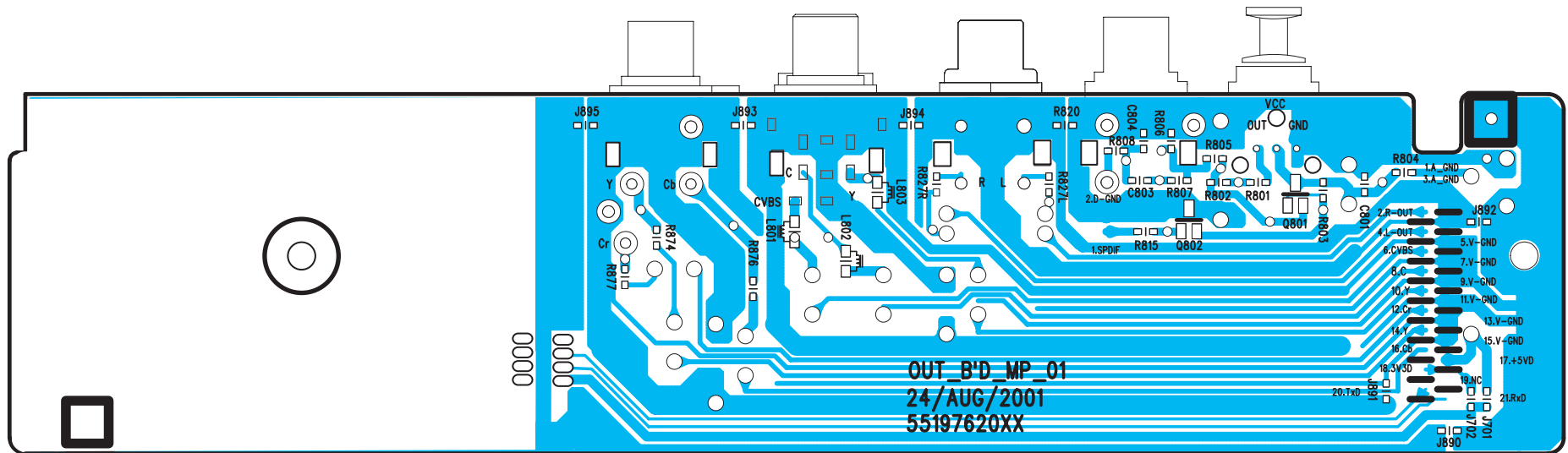

**Soldering side view**

4

# PRINTED CIRCUIT BOARD VIEW

### Open/Close switch PC board

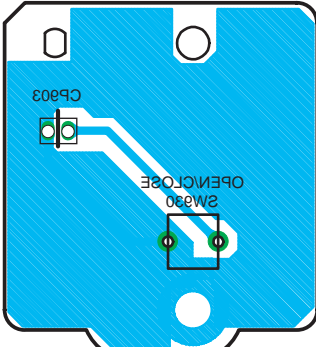

Soldering side view

### Standby switch PC board

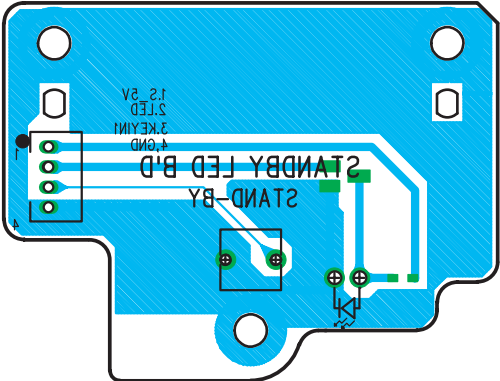

Component side view

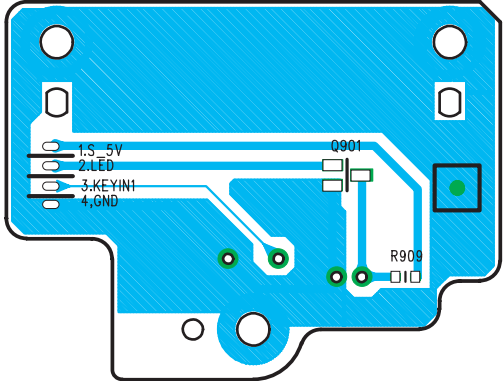

Soldering side view

### Connection PC board

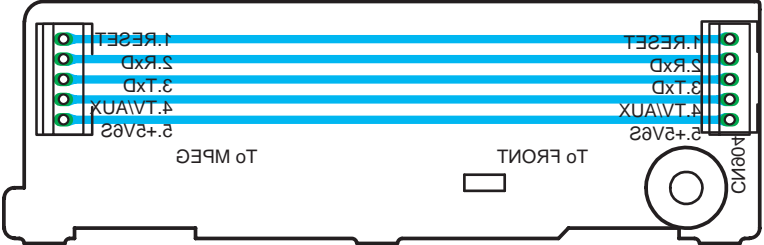

Component side view

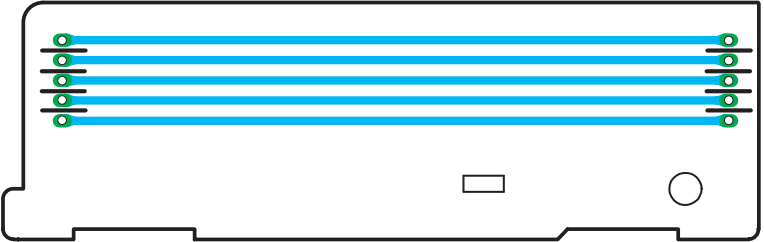

Soldering side view





## PRINTED CIRCUIT BOARD PARTS LIST

### MECHANISM CONTROL PC BOARD ASSY (PART NO. 55186040)

CIRCUIT NO.	PART NO.	DESCRIPTION
	<b>ICs</b>	
IC001,IC002	20656300NR	LB1641
	<b>Diodes</b>	
D001,D002	2041428001	1N5232B, 5.6V, Zener
	<b>Photo diodes</b>	
PI001-PI003	20586840NR	ITR9606/F2
PI004	20556130NR	GP2S28 20M
	<b>Coil</b>	
L001	20265120NR	LF 39U0H +10% 130M
	<b>Capacitors</b>	
C001,C003	8043459071	22pF,+/-5%, Ceramic (CH)
C002,C004	20246950AF	0.1uF,+/-10%, Ceramic
C005	20268030AM	1000uF,+/-20%, 25V, Elect
	<b>Socket</b>	
P003	20504010XX	2.0MM 6 MA ST
P027	20713500NR	06187F
P406	55183020NR	
	<b>Resistors</b>	
R001,R002	5088295016	100 ohm, +/-5%, 1/6W
R003,R004	2054943001	2.2 ohm, +/-5%, 1/2W



# PRINTED CIRCUIT BOARD PARTS LIST

## OUTPUT TERMINAL PC BOARD

CIRCUIT NO.	PART NO.	DESCRIPTION
	<b>IC</b>	
IC805	55164740NR	Optical output terminal
	<b>Tansistors</b>	
Q801	2097046092	KTC3875Y
Q802	2097048092	KTA1504Y
	<b>Diode</b>	
D711	7043654016	1N4148
	<b>Coils</b>	
L801-L803	5512671050	
	<b>Socket</b>	
CN01	55124600XX	1.25mm, 19P
CP01	55090070XX	2.0mm, 2P
	<b>Capacitors</b>	
C801	2026729091	0.1uF, +80-0%, Chip
C802	2026783030	47uF,+/-20%, 16V, Elect
C803	1105934091	0.01uF, +/-10%, Chip
C804	1105867091	100pF, +/-5%, Chip
C820-C822, C825	2026862030	470uF,+/-20%, 6.3V, Elect
C823,C824	2025265030	220uF,+/-20%, 16V, Elect
	<b>Resistors</b>	
J893-J895	8044051091	o ohm
	<b>Terminals</b>	
JK801	55164750XX	Coaxial output
JK802	55175260XX	RCAV2P, Audio output
JK803	55191220XX	RCA1P, Video output
JK804	55149420XX	RCV3V, Component output

## PRINTED CIRCUIT BOARD PARTS LIST

### MECHANISM CONTROL PC BOARD ASSY (PART NO. 55183130)

CIRCUIT NO.	PART NO.	DESCRIPTION
	<b>ICs</b>	
IC001,IC002	20656300NR	LB1641
	<b>Diodes</b>	
D001,D002	2041428001	1N5232B, 5.6V, Zener
	<b>Photo diodes</b>	
PI001-PI003	20586840NR	ITR9606/F2
PI004	20556130NR	GP2S28 20M
	<b>Coil</b>	
L001	20265120NR	LF 39U0H +10% 130M
	<b>Capacitors</b>	
C001,C003	8043459071	22pF,+/-5%, Ceramic (CH)
C002,C004	20246950AF	0.1uF,+/-10%, Ceramic
C005	20268030AM	1000uF,+/-20%, 25V, Elect
	<b>Socket</b>	
P003	20504010XX	2.0MM 6 MA ST
P027	20713500NR	06187F
P406	55183020NR	
	<b>Resistors</b>	
R001,R002	5088295016	100 ohm, +/-5%, 1/6W
R003,R004	2054943001	2.2 ohm, +/-5%, 1/2W

## PANEL VIEW

### FL DISPLAY

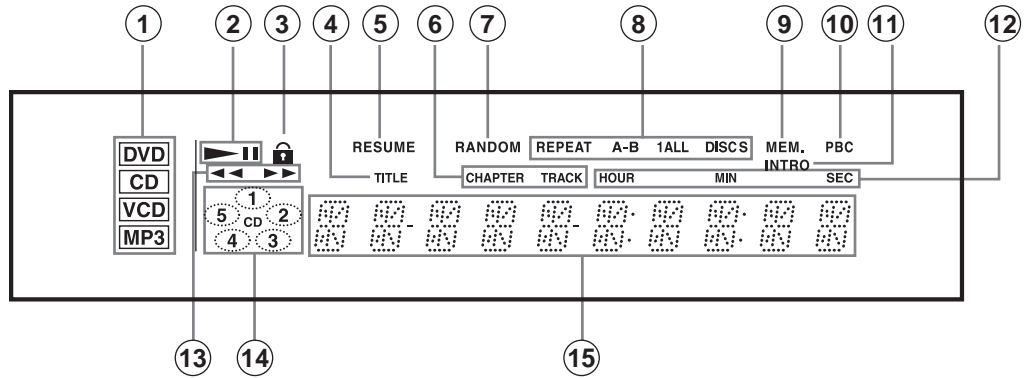

- ① **Inserted disc indicators**  
Indicate the type of current disc that is loaded.
- ② **Play/Pause indicators**  
Illuminate in play or pause mode.
- ③ **Parental Lock indicator**  
Illuminates in parental lock mode.
- ④ **TITLE indicator**  
Illuminates to indicate the current title number.
- ⑤ **RESUME indicator**  
Illuminates when the player is ready for resume playback.
- ⑥ **CHAPTER/TRACK indicators**  
Indicate display mode of the current chapter of DVD disc or track number of Video CD or CD.
- ⑦ **RANDOM indicator**  
Illuminates during random playback.
- ⑧ **REPEAT indicators**  
Illuminate during repeat playback.
- ⑨ **MEM. indicator**  
Illuminates during memory playback.
- ⑩ **PBC indicator**  
Illuminates when PBC is on for Video CD.
- ⑪ **INTRO indicator**  
Illuminates during intro-scan playback.
- ⑫ **Elapsed time indicators**  
Indicate playing time.
- ⑬ **Search indicators**  
Illuminate during search and slow playback mode.
- ⑭ **Disc number indicator/CD indicator**  
Disc number indicators indicate the presence of a disc. CD indicator illuminates when the DVD Changer is in CD Play mode.
- ⑮ **Multifunction indicator**  
Indicates operating status, messages, etc.

## MICROPROCESSOR TERMINAL DESCRIPTION

## IC901 CXP82532 PIN LIST

PIN NUMBER	PIN NAME	MAIN FUNCTION	IN/OUT
1	PE3/INT3	INPUT FOR EXTERNAL INTERRUPT REQUEST.	I
2	PE4/RMC	INPUT FOR REMOTE CONTROL RECEIVING CIRCUIT.	I
3	PE5	-	I
4	PE6	-	O
5	PE7/TO	OUTPUT PIN FOR 16-BIT TIME/COUNTER RECTANGULAR WAVEFORM.	O
6	PBO/CINT	EXTERNAL CAPTURE INPUT FOR 16-BIT TIME/COUNTER.	I/O
7	PBI/CSO	CHIP SELLECT INPUT FOR SERIAL INTERFACE(CH0).	I/O
8	PB2/SCKO	SERIAL CLOCK (CH0) INPUT/OUTPUT.	I/O
9	PB3/SIO	SERIAL DATA (CH0) INPUT.	I/O
10	PB4/SOO	SERIAL DATA (CH0) OUTPUT.	I/O
11	PB5/SCK1	SERIAL CLOCK (CH1) INPUT/OUTPUT.	I/O
12	PB6/SI1	SERIAL DATA (CH1) INPUT.	I/O
13	PB7/SO1	SERIAL DATA (CH1) OUTPUT.	O
14	PCO/KRO	KEY RETURN INPUT FOR FDP SEGMENT SIGNAL WITCH PERFORMS KEY SCANNING.	I/O
15	PC1/KR1	KEY RETURN INPUT FOR FDP SEGMENT SIGNAL WITCH PERFORMS KEY SCANNING.	I/O
16	PC2/KR2	KEY RETURN INPUT FOR FDP SEGMENT SIGNAL WITCH PERFORMS KEY SCANNING.	I/O
17	PC3/KR3	KEY RETURN INPUT FOR FDP SEGMENT SIGNAL WITCH PERFORMS KEY SCANNING.	I/O
18	PC4/KR4	KEY RETURN INPUT FOR FDP SEGMENT SIGNAL WITCH PERFORMS KEY SCANNING.	I/O
19	PC5/KR5	KEY RETURN INPUT FOR FDP SEGMENT SIGNAL WITCH PERFORMS KEY SCANNING.	I/O
20	PC6/KR6	KEY RETURN INPUT FOR FDP SEGMENT SIGNAL WITCH PERFORMS KEY SCANNING.	I/O
21	PC7/KR7	KEY RETURN INPUT FOR FDP SEGMENT SIGNAL WITCH PERFORMS KEY SCANNING.	I/O
22	PA0/AN0	ANALOG INPUT TO A/D CONVERTER.	I/O
23	PA1/AN1	ANALOG INPUT TO A/D CONVERTER.	I/O
24	PA2/AN2	ANALOG INPUT TO A/D CONVERTER.	I/O
25	PA3/AN3	ANALOG INPUT TO A/D CONVERTER.	I/O
26	PA4/AN4	ANALOG INPUT TO A/D CONVERTER.	I/O
27	PA5/AN5	ANALOG INPUT TO A/D CONVERTER.	I/O
28	PA6/AN6	ANALOG INPUT TO A/D CONVERTER.	I/O
29	PA7/AN7	ANALOG INPUT TO A/D CONVERTER.	I/O
30	'RESET	SYSTEM RESET,ACTIVE "L"	I/O
31	EXTAL	CONNECTION FOR SYSTEM CLOCK OSCILLATION CRYSTAL.	I
32	XTAL	CONNECTION FOR SYSTEM CLOCK OSCILLATION CRYSTAL.	-
33	VSS	GND	-
34	PD0/S0	8-BIT DEDICATED OUTPUT PORT/SEGMENT SIGNAL OUTPUT FOR FDP.	O
35	PD1/S1	8-BIT DEDICATED OUTPUT PORT/SEGMENT SIGNAL OUTPUT FOR FDP.	O
36	PD2/S2	8-BIT DEDICATED OUTPUT PORT/SEGMENT SIGNAL OUTPUT FOR FDP.	O
37	PD3/S3	8-BIT DEDICATED OUTPUT PORT/SEGMENT SIGNAL OUTPUT FOR FDP.	O
38	PD4/S4	8-BIT DEDICATED OUTPUT PORT/SEGMENT SIGNAL OUTPUT FOR FDP.	O
39	PD5/S5	8-BIT DEDICATED OUTPUT PORT/SEGMENT SIGNAL OUTPUT FOR FDP.	O
40	PD6/S6	8-BIT DEDICATED OUTPUT PORT/SEGMENT SIGNAL OUTPUT FOR FDP.	O
41	PD7/S7	8-BIT DEDICATED OUTPUT PORT/SEGMENT SIGNAL OUTPUT FOR FDP.	O
42	PF0/S8	8-BIT DEDICATED OUTPUT PORT/SEGMENT SIGNAL OUTPUT FOR FDP.	O
43	PF1/S9	8-BIT DEDICATED OUTPUT PORT/SEGMENT SIGNAL OUTPUT FOR FDP.	O
44	PF2/S10	8-BIT DEDICATED OUTPUT PORT/SEGMENT SIGNAL OUTPUT FOR FDP.	O
45	PF3/S11	8-BIT DEDICATED OUTPUT PORT/SEGMENT SIGNAL OUTPUT FOR FDP.	O
46	PF4/S12	8-BIT DEDICATED OUTPUT PORT/SEGMENT SIGNAL OUTPUT FOR FDP.	O
47	PF5/S13	8-BIT DEDICATED OUTPUT PORT/SEGMENT SIGNAL OUTPUT FOR FDP.	O

## DISASSEMBLY PROCEDURE

### Replacement of DVD mechanism

The laser diode in the optical pickup block so sensitive to static electricity, surge current and etc..

That the components are liable to be broken down or its reliability remarkable deteriorated.

During repair, carefully take the following precautions.

Do not touch the optical pickup object lens with the hands.

#### Short Land

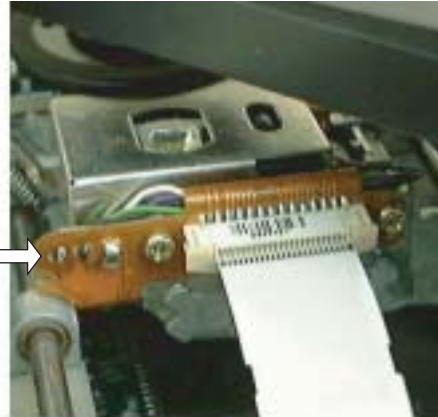
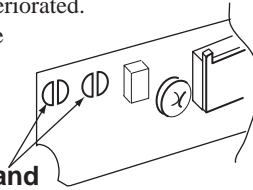

1. Remove the top cover with six screws.
2. Remove the tray.
3. Remove the roulette assembly.
4. Remove the roulette. (Roulette is removed as written below.)
5. Solder the LD output lands on the DVD optical pickup.  
Please perform right photo to reference.
6. Replace the pickup mechanism assembly etc. . After unsolder the laser diodes output lands.

### Remove the roulette

1. Pull out the tray.
2. Stops in the position (cut deeply).
3. Remove in the direction of arrow.
4. Reassembly is performed by 3 to 1.

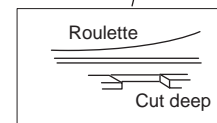

PACKING VIEW

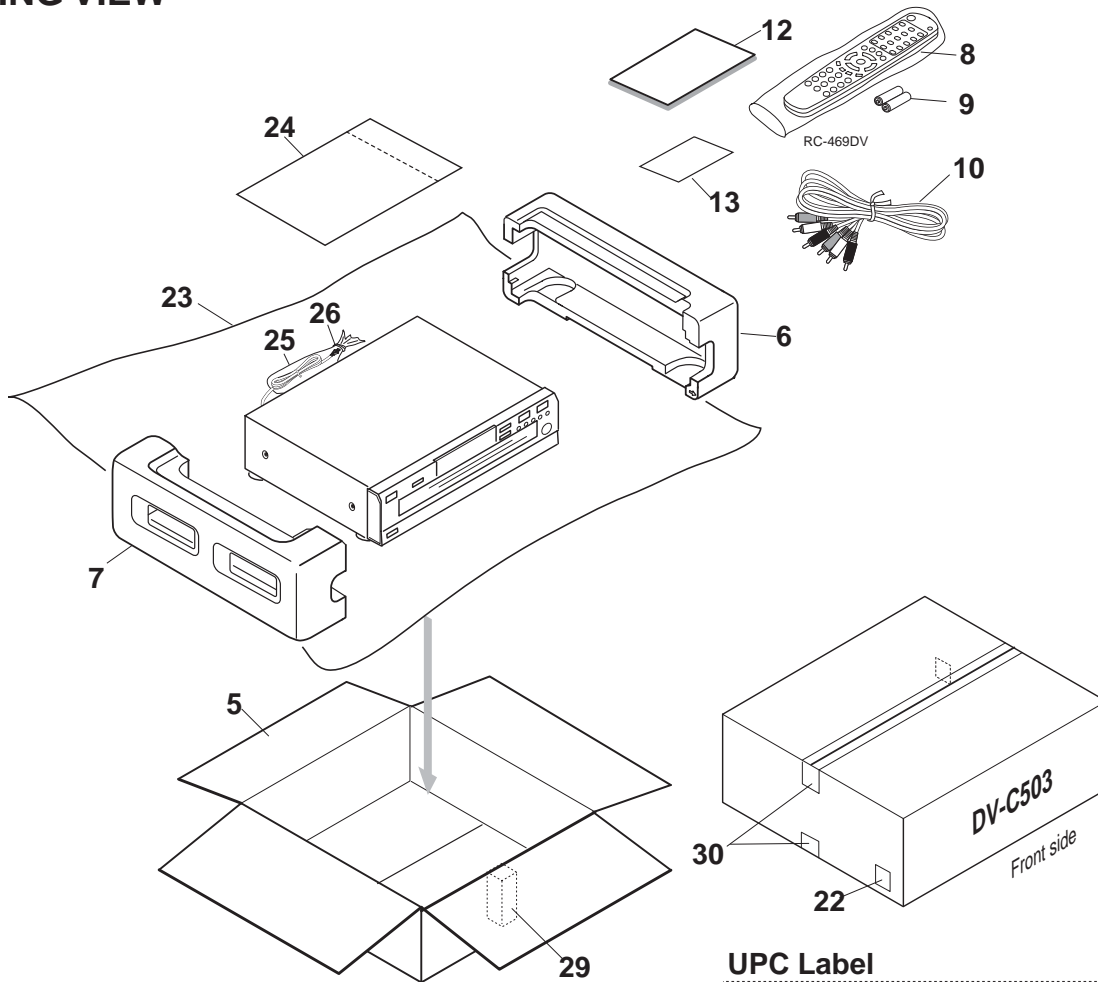

UPC Label

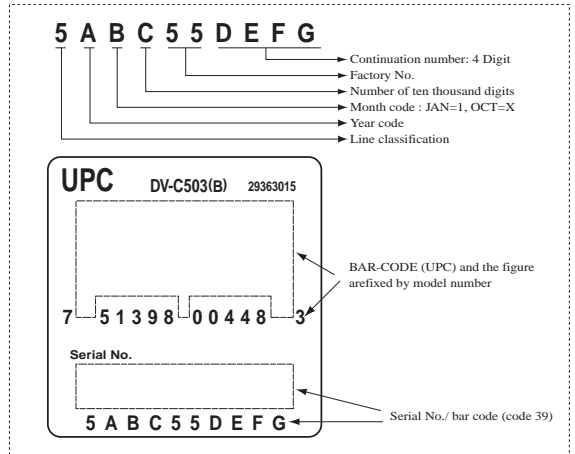

PARTS LIST

NO.	PART NO.	DESCRIPTION	NO.	PART NO.	DESCRIPTION
5	55184380	Carton box	13	55186720	Warranty card
6	55184410	Pad, Right	22	55184430	UPC label
7	55184420	Pad, Left	23	55170660	Sheet, 1150 x 1000
8	55184440	Remote controller RC-469DV	24	55170650	Polybag, Instruction manual
9	3010124	Battery, UM-4 x 2	25	20715540	Polybag, Power cord
10	55176530	Audio/ Video connection cable	26	—	Cable tie
12	55184460	Instruction manual	29	55208740	Cushion, 35sq x 80
			30	29110141	PP Tape

## UPGRADE THE FIRMWARE 1

- a. The program for writing
  - b. The program of binary form AAAABBB.bin
- Two files are saved to the same directory.
- AAAA : model name  
 BBB : Version

### 1. Jigs connection

#### 1-1. PC-JIG

Connect the D-Sub(25 pin) cable.

#### 1.2. JIG-DV-C503

Connect the FFC and socket (down load PCB).

#### 1.3. Remove a sheet at the bottom.

Connect the socket (CP202).

#### 1-4. Turn on the power switch of DV-C503.

Light up the LED on the JIG PC board assy.

#### 1-5. Start an MS-DOS window.

(Click **Strat**, point to **Programs**, point to **Accessories**, and then click **MS-DOS Prompt**.)

#### 1-6. Input key the "dvd down AAAABBB.bin" and then click **Return**.

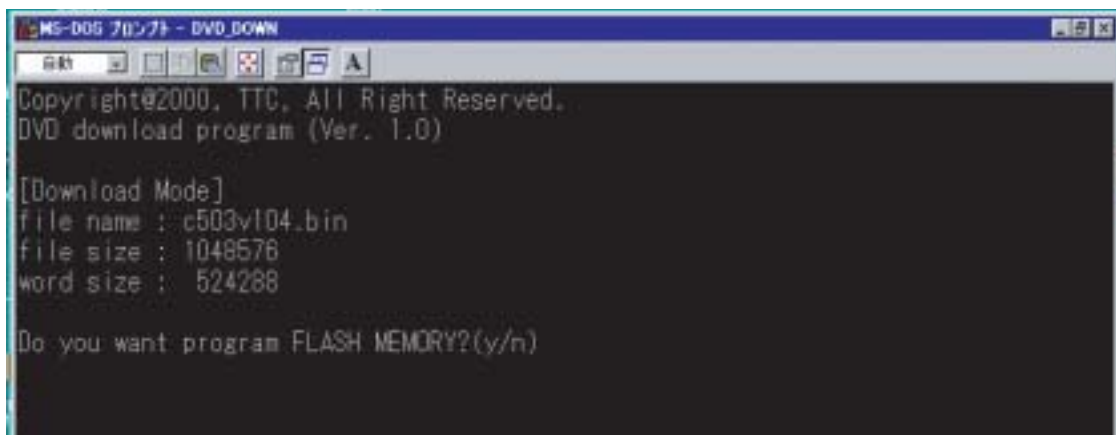
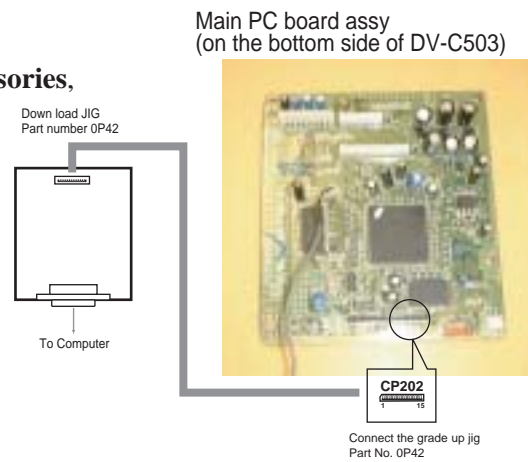

## UPGRADE THE FIRMWARE 2

### 1-7. Key input "Y".

It is automatically written in order of Identify, ROM ERASE, WRITE and Verify.  
Writing time are about 1 minute

```

MS-DOS 7.0571 - DVD Down
Copyright©2000, TTC, All Right Reserved.
DVD download program (Ver. 1.0)

[Download Mode]
file name : c503v104.bin
file size : 1048576
word size : 524288

Do you want program FLASH MEMORY?(y/n)
Identify! ---Done!
Erase now ...
Transfer Size ----
Transfer Data---- count: 1048576 [100%]
Verify... count: 1048576 [100%]

Complete (press any key)
  
```

Writing was completed. →

### 1-8. Press any key.

## 2. Confirmation of version of firmware

### 2-1. Press the "DIS 3" and "CDPLAY" key to the same timing.

The "DISC 3" key is pushed previously.

### 2-2. Version number is displayed on FL tube. (wait several seconds )

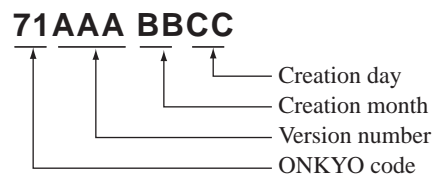



---

**ONKYO CORPORATION**

Sales & Product Planning Div. : 2-1, Nisshin-cho, Neyagawa-shi, OSAKA 572-8540, JAPAN  
Tel: 072-831-8111 Fax: 072-833-5222

**ONKYO U.S.A. CORPORATION**

18 Park Way, Upper Saddle River, N.J. 07458, U.S.A.  
Tel: 201-785-2600 Fax: 201-785-2650 E-mail: onkyo@onkyousa.com

**ONKYO EUROPE ELECTRONICS GmbH**

Industriestrasse 20, 82110 Germering, GERMANY  
Tel: 089-849-320 Fax: 089-849-3265 E-mail: info@onkyo.de

**ONKYO CHINA LIMITED**

Units 2102-2107, Metroplaza Tower I, 223 Hing Fong Road, Kwai Chung,  
N.T., HONG KONG Tel: 852-2429-3118 Fax: 852-2428-9039