

ONKYO® SERVICE MANUAL

DVD CHANGER MODEL DV-C600

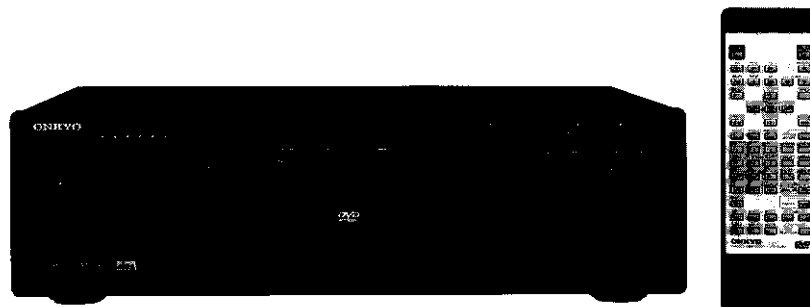

BMD	120V AC, 60Hz
BMP	100-240V AC, 50/60Hz
BMPA	100-240V AC, 50/60Hz

SAFETY-RELATED COMPONENT WARNING!!

COMPONENTS IDENTIFIED BY MARK \triangle ON THE SCHEMATIC DIAGRAM AND IN THE PARTS LIST ARE CRITICAL FOR RISK OF FIRE AND ELECTRIC SHOCK. REPLACE THESE COMPONENTS WITH ONKYO PARTS WHOSE PART NUMBERS APPEAR AS SHOWN IN THIS MANUAL.



MAKE LEAKAGE-CURRENT OR RESISTANCE MEASUREMENTS TO DETERMINE THAT EXPOSED PARTS ARE ACCEPTABLY INSULATED FROM THE SUPPLY CIRCUIT BEFORE RETURNING THE APPLIANCE TO THE CUSTOMER.

TABLE OF CONTENTS

Operating instructions Safety precautions-----	2
Specifications-----	3
Front panel/ Rear panel views-----	4
DVD display/ Remote controller views-----	5
Block diagram-----	6
Parts replacement and adjustment procedure-----	7-17
Replacement of optical pickup-----	18
Exploded view-----	19-20
Exploded parts list-----	21
Exploded view (Roulet mecha.)-----	22
Exploded view (Mechanism)-----	23
Roulette mechanism parts list-----	24
Location of mechanism parts-----	25-26
Electric parts list-----	27-28, 37
Schematic diagram-----	29-36
Printed circuit board view(Roulet mecha.)-----	38
Microprocessor terminal description-----	39-40
IC Block diagram-----	41-42
Trouble shooting-----	43-50
Printed circuit board view-----	51-56
PC board connection diagram-----	57-58
Main PC board view-----	59-62
DVD mechanism/ Main PC board parts list-----	63-64
Upgrade firmware-----	65-67
Packing view-----	68



OPERATING INSTRUCTIONS SAFETY PRECAUTIONS

	WARNING RISK OF ELECTRIC SHOCK DO NOT OPEN	
AVIS	RISQUE DE CHOC ELECTRIQUE NE PAS OUVRIR	
WARNING : TO REDUCE THE RISK OF ELECTRIC SHOCK, DO NOT REMOVE COVER (OR BACK). NO USER-SERVICEABLE PART INSIDE. REFER SERVICING TO QUALIFIED SERVICE PERSONNEL.		



The lightning flash with arrowhead symbol, within an equilateral triangle, is intended to alert the user to the presence of uninsulated "dangerous voltage" within the product's enclosure that may be of sufficient magnitude to constitute a risk of electric shock to persons.



The exclamation point within an equilateral triangle is intended to alert the user to the presence of important operating and maintenance (servicing) instructions in the literature accompanying the appliance.

WARNING : TO REDUCE THE RISK OF FIRE OR ELECTRIC SHOCK, DO NOT EXPOSE THIS APPLIANCE TO RAIN OR MOISTURE. DANGEROUS HIGH VOLTAGES ARE PRESENT INSIDE THE ENCLOSURE. DO NOT OPEN THE CABINET. REFER SERVICING TO QUALIFIED PERSONNEL ONLY.

CAUTION : TO PREVENT ELECTRIC SHOCK, MATCH WIDE BLADE OF PLUG TO WIDE SLOT, FULLY INSERT.

ATTENTION : POUR EVITER LES CHOCES ELECTRIQUE, INTRODUIRE LA LAME LA PLUS LARGE DA LA FICHE DANS LA BORNE CORRESPONDANTE DA LA PRISE ET POUSSER JUSQU' AU FOND.

PRECAUTIONS

Replacing the fuses

For continued protection against risk fire, replace only with same type and same rating fuse.

CIRCUIT No.	PART No.	DESCRIPTION
F901 <MD>	252157	1.25A-UL/T-237
F901 <MP/MPA>	252071	1.25A-SE-E-AWK

 This symbol located near the fuse indicates that the fuse used is fast operating type. For continued protection against fire hazard, replace with same type fuse. For fuse rating refer to the marking adjacent to the symbol.

 Ce symbole indique que le fusible utilise est a rapide. Pour une protection permanente, n'utiliser que des fusibles de meme type. Ce dernier est indique la qu le present symbol est appose.

LASER BEAM CAUTION LABEL

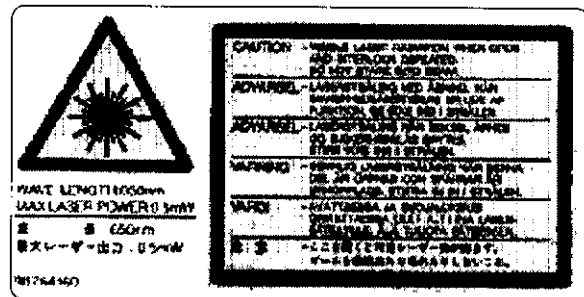

The label features a laser beam symbol (a starburst) within a triangle. Below the symbol, it lists 'MAX LASER POWER 0.5mW' and 'MAX LASER LENGTH 500mm'. The text is provided in English, French, and Japanese.

When the power supply is being turned on, you may not remove this laser caution label, radiation of a laser may be received. Pickup Head consists of a laser diode that is very susceptible to external static electricity. Although it operates properly after replacement, if it was subject to electrostatic discharge during replacement, its life might be shortened. When replacing, use a conductive mat, soldering iron with ground wire, etc. to protect the laser diode from damage by static electricity. And also, the LSI and IC are same as above.

SPECIFICATIONS

DVD Changer

Power supply	AC 120 V, 60 Hz (MD) AC 100-240 V, 50/60 Hz (MP/MPA)
Power consumption	19 W
Weight	7.0 kg
External dimensions	435 x 131 x 433 mm (W/H/D)
Signal system	Standard NTSC (MD), PAL / 3.58 NTSC (MP/MPA)
Laser	Semiconductor laser, wavelength 650 nm
Frequency range (digital audio)	DVD linear sound : 48 kHz sampling 4 Hz to 22 kHz 96 kHz sampling 4 Hz to 44 kHz Audio CD : 4 Hz to 20 kHz
Signal-to-noise ratio (digital audio)	More than 96 dB (EIAJ)
Audio dynamic range (digital audio)	More than 90 dB (EIAJ)
Harmonic distortion (digital audio)	Less than 0.01 %
Wow and flutter	Below measurable level (less than ± 0.001 % (W .PEAK)) (EIAJ)
Operating conditions	Temperature: 5°C to 35°C (41 to 95 degrees), Operation status: Horizontal

Outputs

Video output	1.0 V (p-p), 75 Ω , negative sync., pin jack x 1
S video output	(Y) 1.0 V (p-p), 75 Ω , negative sync., Mini DIN 4-pin x 1 (C) 0.286 V (p-p), 75 Ω
Component Video output (MD)	(Y) 1.0 V (p-p), 75 Ω , negative sync., pin jack x 1 (Cb)/(Cr) 0.7 V (p-p), 75 Ω
Digital Audio output (optical)	Optical connector x 1
Digital Audio output (coaxial)	0.5 V (p-p), 75 Ω , pin jack x 1
Audio output (analog audio)	2.0 V (rms), 470 Ω , pin jack (L, R) x 1

* Design and specifications are subject to change without notice.

BLOCK DIAGRAM

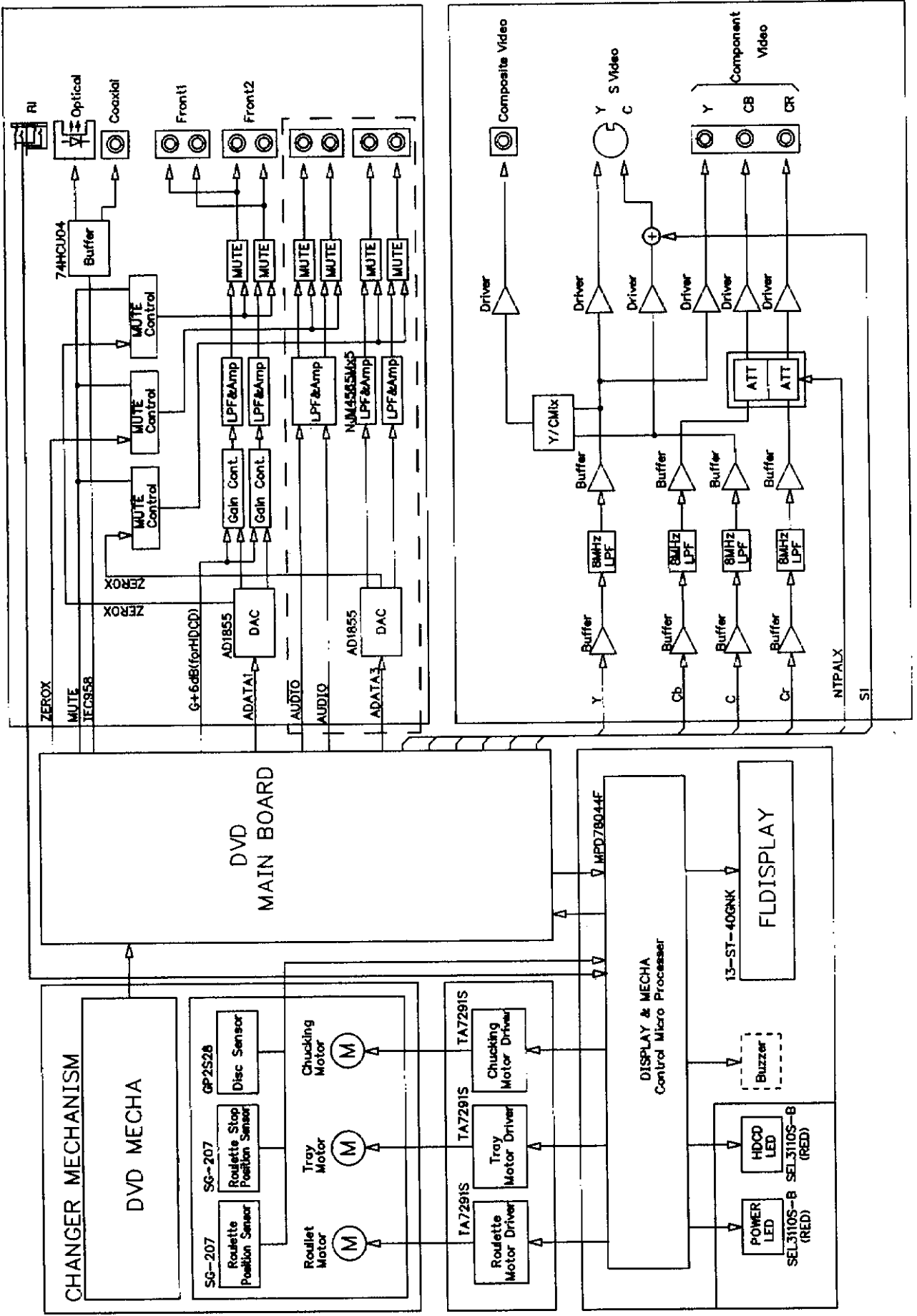

1. REPLACEMENT OF MECHANICAL PARTS

1-1. Cabinet Replacement

1-1-1. Top Cover

1. Remove 7 screws (1) and remove the top cover (2).

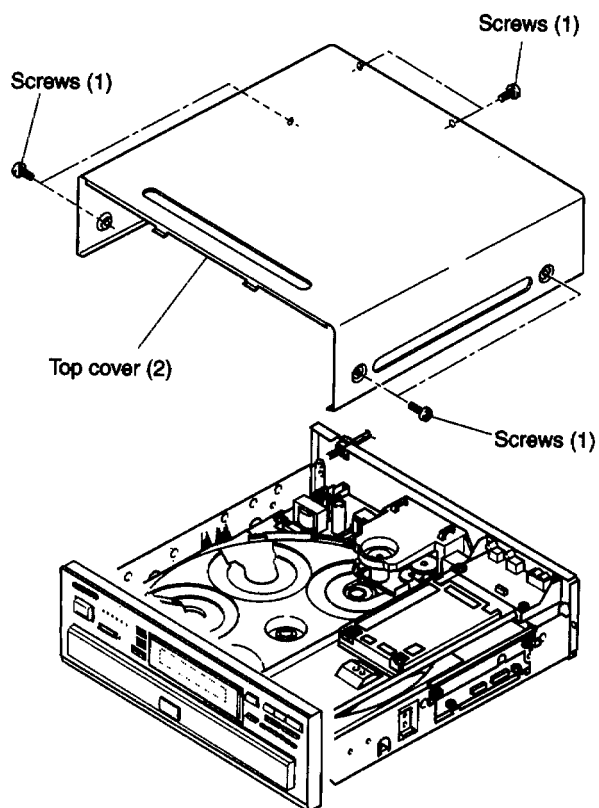

Fig. 2-1-1

1-1-2. Tray Panel

1. Eject the tray (1).
2. Twist the tray panel (2) a little in the arrow A direction with the tray (1) held to release two claws and lift up the tray panel (2) in the arrow B direction, then the tray panel (2) is removed.
3. When mounting the tray panel (2), insert the tray panel (2) along the groove of the both sides of the tray (1) until it clicks.

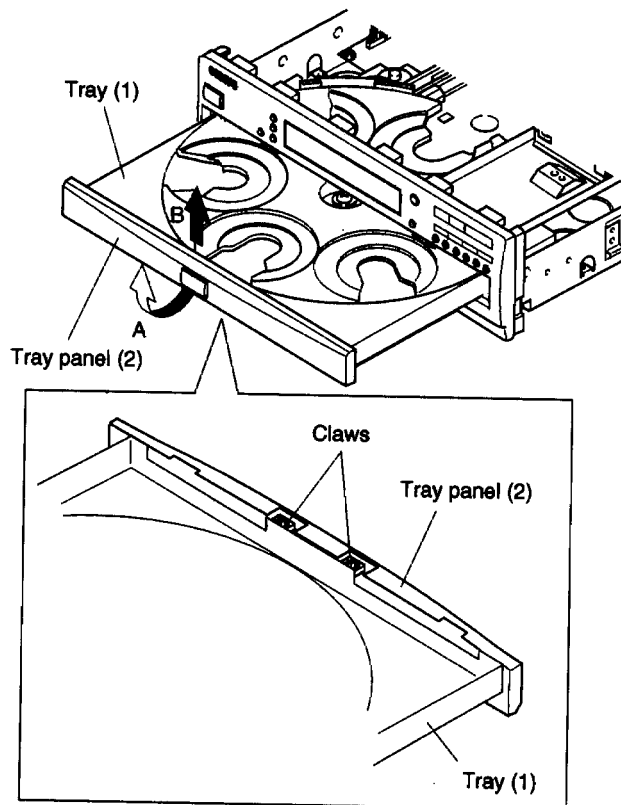

Fig. 2-1-2

1-1-3. Front Panel

1. Remove three screws(4) of the aluminum front panel.
2. Pull out the tray and remove the tray panel.
(Refer to item Fig.2-1-2)
3. Remove three screws(6) of the front bracket.
4. Peel off the tape(1) and disconnect the FFC(2).
5. Disconnect the FFC(3).
6. Remove the bosses of the front panel(9).

NOTE:

- When connecting the FFC(2), be sure to insert it to the connector after passing through the FFC band.

1-2. PC Board Replacement

1-2-1. Main PC Board

1. Peel off the tape(1).
2. Disconnect five FFCs(4) and one connector(3).

Note:

Before disconnecting the FFC from the main PC board, pull out the round bottom cover (attached with both-side adhesive tape) and be sure to short-circuit the LD-SHORT J019 by a clip or soldering.

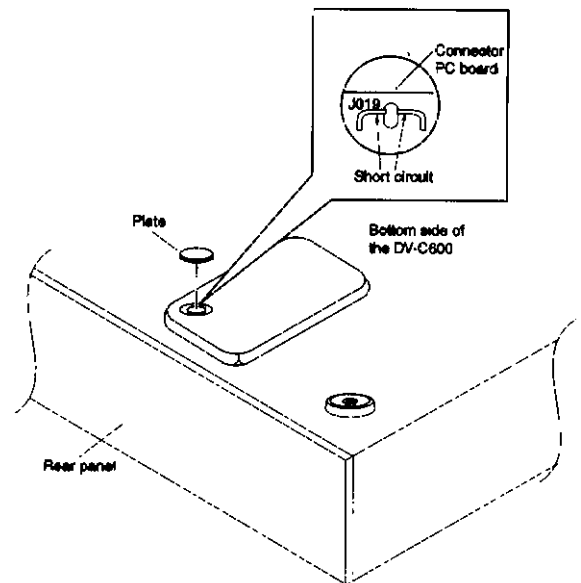

Fig. 2-1-5

1-1-4. Rear panel

1. Remove the AC cord bushing(1).
2. Remove the 17 screws(2) and remove the rear panel(3).

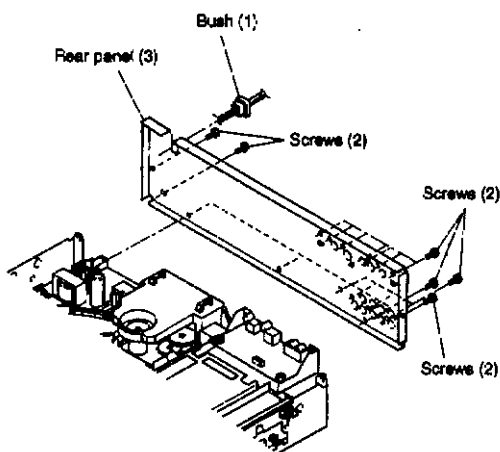

Fig. 2-1-4

DV-C600

1-2-2. Video Output PC Board

1. Disconnect one FFC (1) and one connector (2).
2. Remove two screws (3).
3. Remove four screws (4) and remove the video output PC board (5).

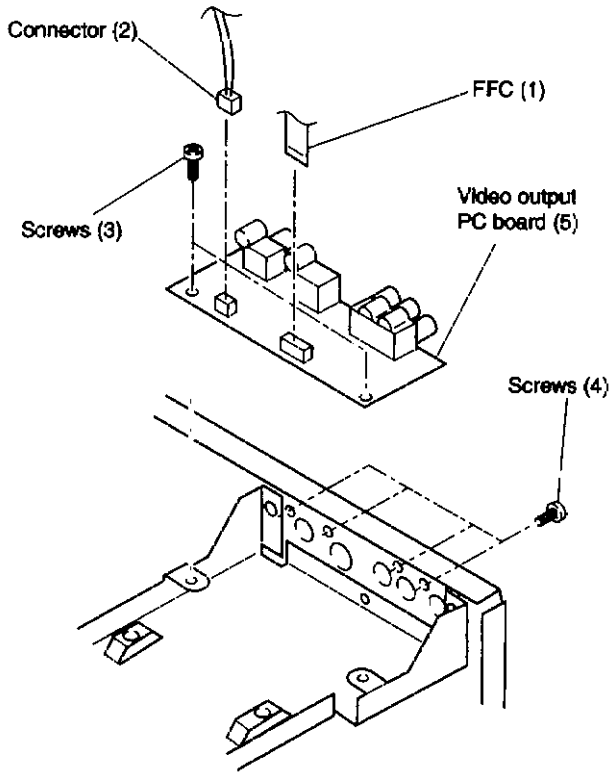

Fig. 2-1-6

1-2-3. Mechanism Drive/Audio Output PC Board

1. Peel off the tape (1).
2. Disconnect five FFCs (2) and two connectors (3).
3. Remove one screw (4) and remove the shield cover (5).
4. Remove seven screws (6) and remove the stay (7).
5. Pull out the tray (8) to this side until it stops.
6. Disconnect two FFCs (9) and three connectors (10).
7. Remove four screws (11) and four screws (12) and remove mechanism drive/audio output PC board (13).

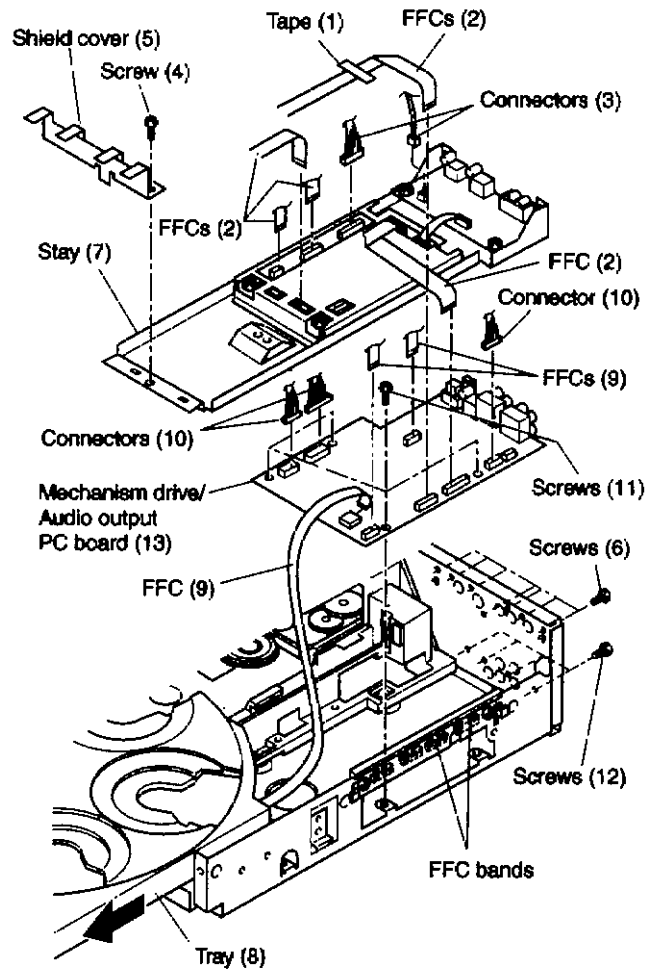

Fig. 2-1-7

1-2-4. Power Supply PC Board

1. Pull out the tray to this side until it stops.
2. Remove one screw (1).
3. Disconnect one connector (2).
4. Remove the PC board clip (3) and remove the power supply PC board (4) by lifting upward.

(The power supply PC board (4) is connected to the DC power PC board (5) with the connector (6).)

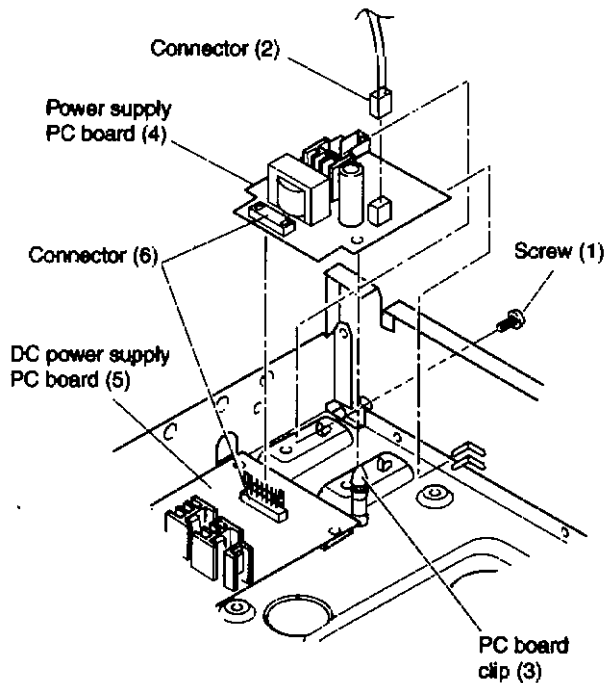

Fig. 2-1-8

1-2-5. DC Power Supply PC Board

1. Remove the power supply PC board. (Refer to item 1-2-4.)
 2. Cut off three cord bands (1).
 3. Remove four screws (2) and remove the DC power supply PC board (3).
- (Refer to Figure A when mounting the cord band (1).)

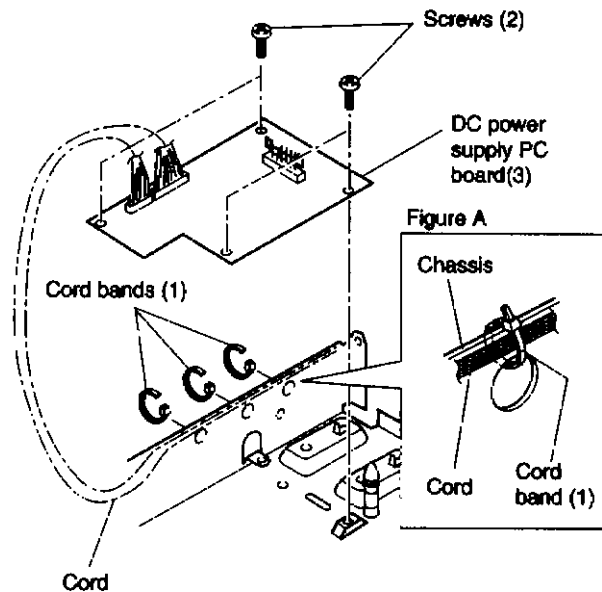

Fig. 2-1-9

1-2-6. Front PC Board and Power Switch PC Board

1. Remove the front panel. (Refer to item 1-1-3.)
2. Remove six screws (1), and remove the metal plate (2) and the front PC board (3).
3. Remove three screws (4) and remove the power switch PC board (5).

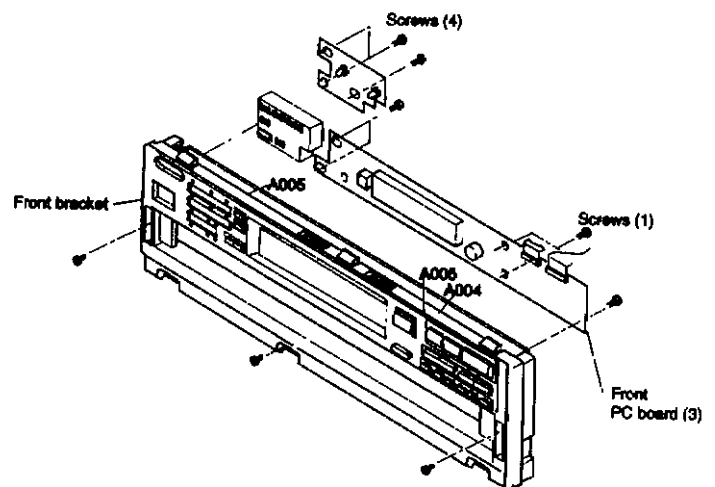

Fig. 2-1-10

1-3. Tray Replacement

1-3-1. Tray

1. Remove the front panel. (Refer to item 1-1-3.)
2. Pull out the tray (1) until it stops.
3. Disconnect one FFC (2).
4. Push the claw and pull out the tray to this side.

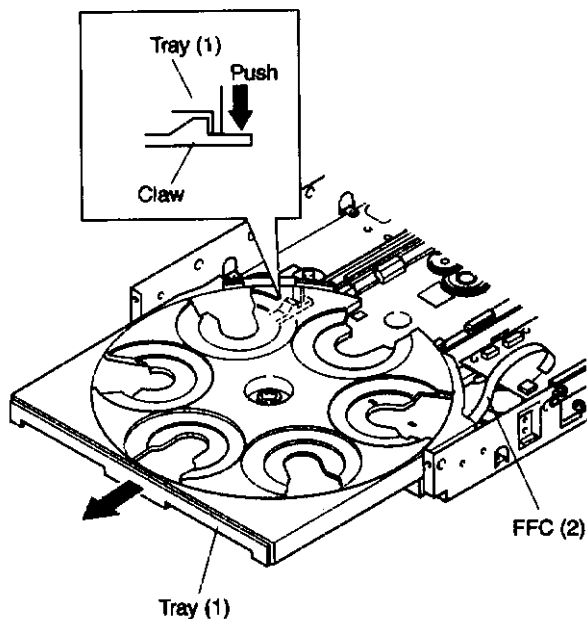

Fig. 2-1-11

1-3-2. Roulette

1. Remove the tray. (Refer to item 1-3-1.)
2. Remove one screw (1) and remove the roulette (2).

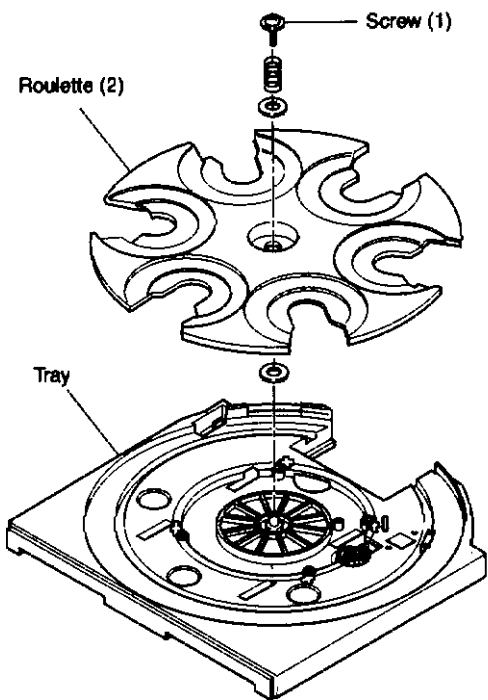

Fig. 2-1-12

1-3-3. Wheel Gear, Worm Gear, Disc Sensor PC Board, Position Sensor PC Board, Loading Motor

1. Remove the tray roulette. (Refer to item 1-3-2.)
2. Remove one screw (1) and remove the wheel gear (2).

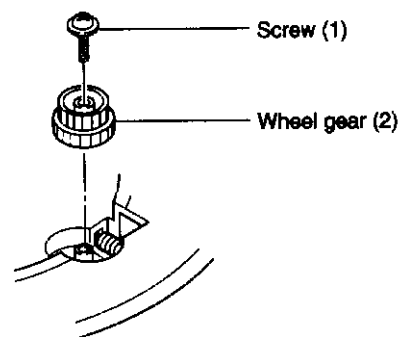

Fig. 2-1-13

3. Turn over the tray.
4. Remove one screw (3), and remove the worm gear (4), pin (5), and belt (6).
5. Remove one screw (7) and remove the disc sensor PC board (8).
6. Remove two screws (9) and remove the motor cover (10).
7. Remove one screw (11) and release three claws, and remove the position sensor PC board (12).
8. Desolder and remove the loading motor (13).

Note:

- Be sure to pass the cords through the cord clamps when wiring.

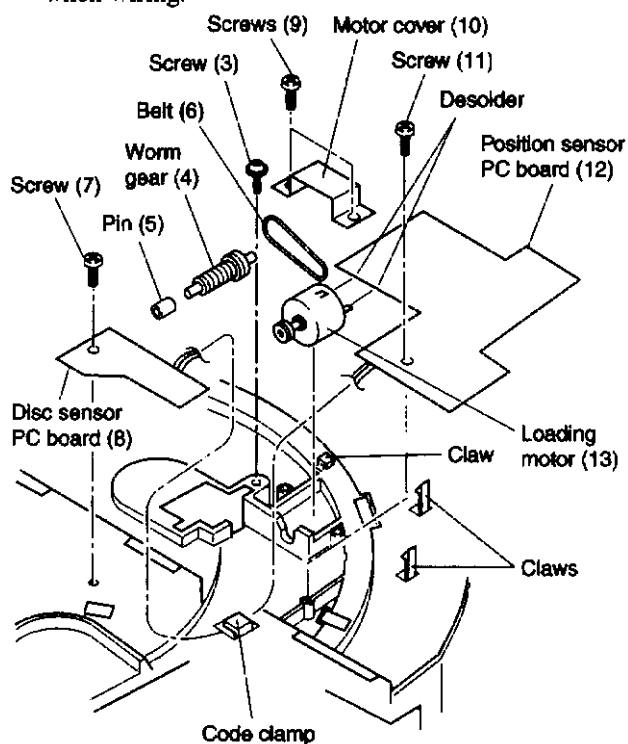

Fig. 2-1-14

1-4. Mechanism Parts Replacement

1-4-1. Mechanism Chassis Assembly

1. Remove the tray. (Refer to item 1-3-1.)
2. Remove two cords (2) from the cord clamps (1).
3. Disconnect one FFC (4) and two connectors (5).
4. Remove seven screws (6).
5. Remove two screws (7) and remove the mechanism chassis assembly (8).

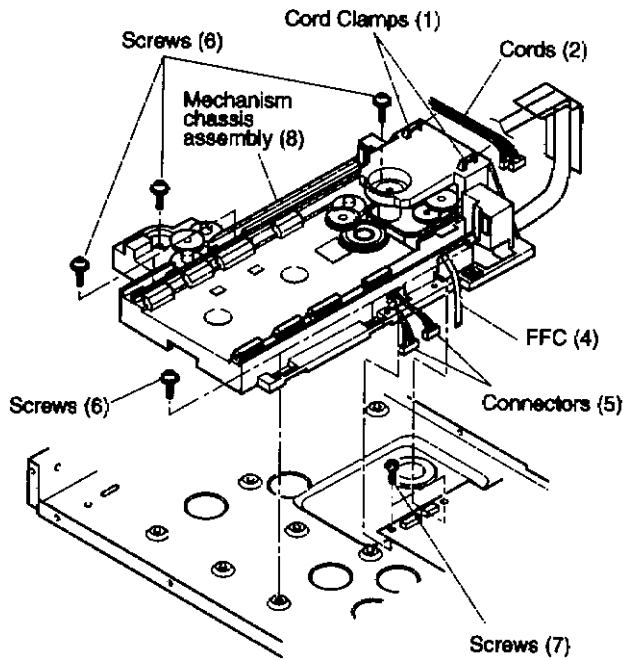

Fig. 2-1-15

1-4-2. Sub Chassis Assembly

1. Remove the mechanism chassis assembly. (Refer to item 1-3-4.)
2. Turn over the mechanism chassis assembly.
3. Remove one screw (1) and remove the sub chassis assembly (2).

Note:

- When mounting, tighten the screw (1) after fitting the boss with the cam groove.

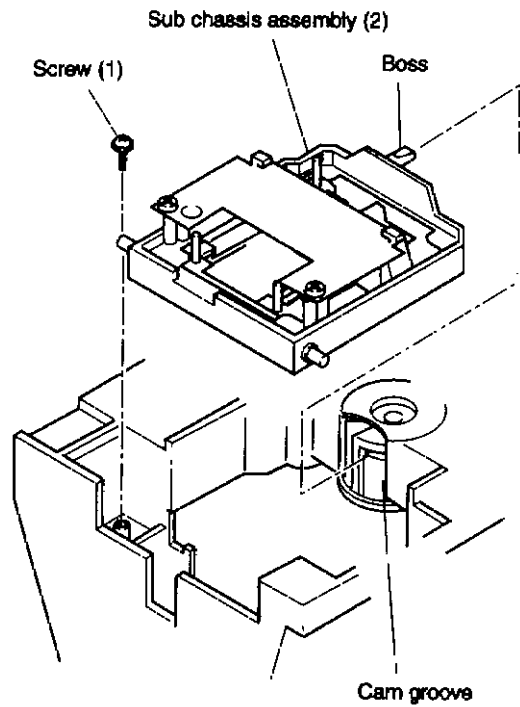

Fig. 2-1-16

1-4-3. LD Short PC Board

1. Remove the sub chassis assembly. (Refer to item 1-4-1.)
2. Remove two screws (1) and remove the LD short PC board (2).

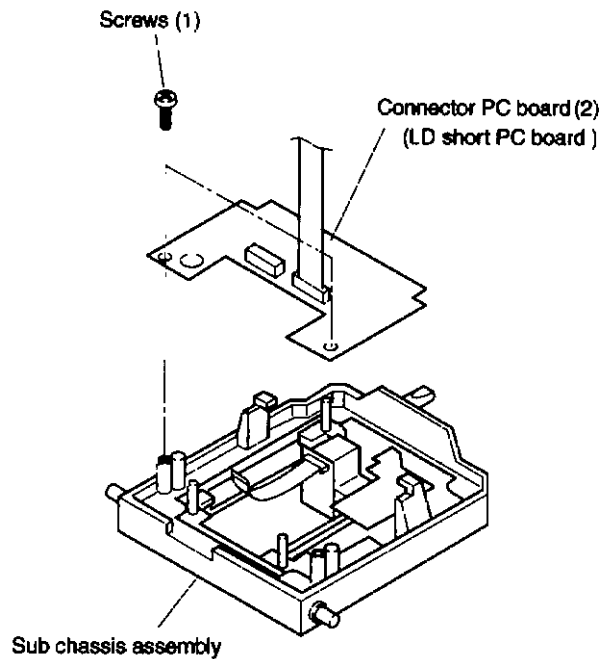

Fig. 2-1-17

1-4-4. Pickup Mechanism Assembly

1. Remove the sub chassis assembly. (Refer to item 1-4-1)
2. Disconnect the FFC (1).
3. Remove four screws (2) and remove the pickup mechanism assembly. (3).

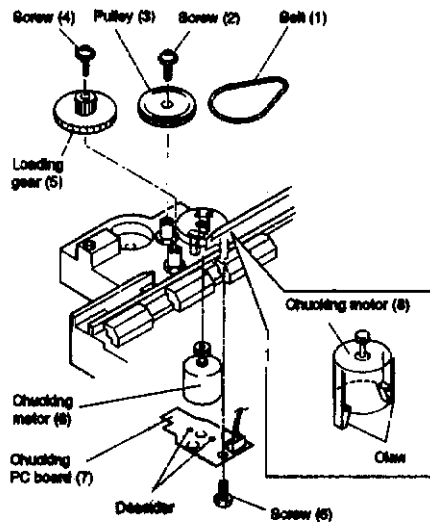

Fig. 2-1-18

Note:

The dampers' color differs when used for the front side and the rear.

when mounting the pickup mechanism assembly (3) with the screws (1), push the pickup mechanism assembly (3) downward without being caught and tighten the screws (1) after placing the washer with the damper bent.

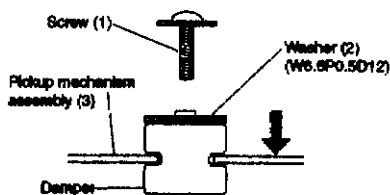

Fig. 2-1-19

1-4-5. Gear B Assembly, Gear A and Rack Gear Assembly

<Removal>

1. Release one claw and remove the gear B assembly (1).
2. Remove the gear A (2).
3. Remove one screw (3) and remove the rack gear assembly (4).

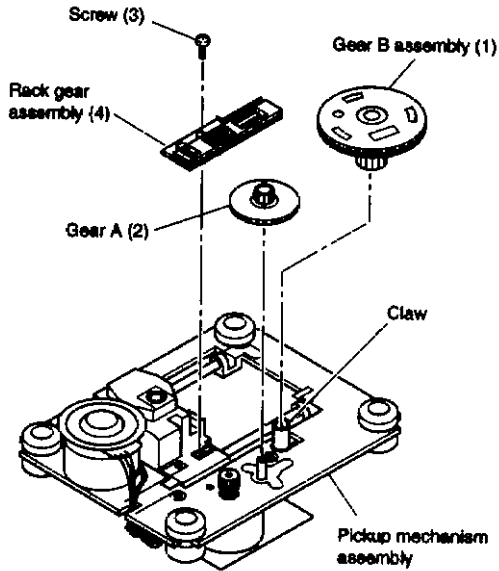

Fig. 2-1-20

<Mounting>

1. When mounting, perform the reverse order of the removal.
2. Mount the gear B assembly (1) by pushing the pickup head (5) to the disc motor side (arrow A direction) and shifting the upper gear of the rack gear assembly (4) in the arrow B direction. (Refer to Fig.2-1-22)
3. Fit the positioning holes on the upper gear and lower gear of the gear B assembly (1) and mount on the pickup mechanism assembly with the phase matched. At this time, note that the phase of the gear B assembly (1) and the gear A (2) show's the status in the Fig.2-1-23.

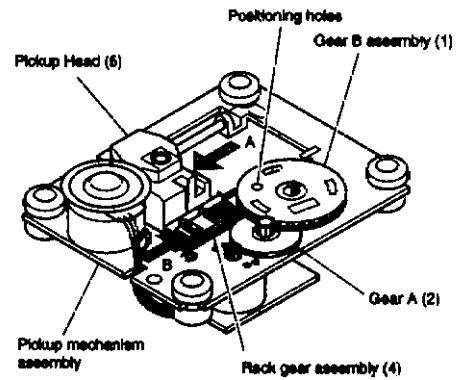

Fig. 2-1-21

Note:

- Mount the gear B assembly (1) and the gear a (2) with their gear teeth placed more than on tooth at least inside the shaded portion.

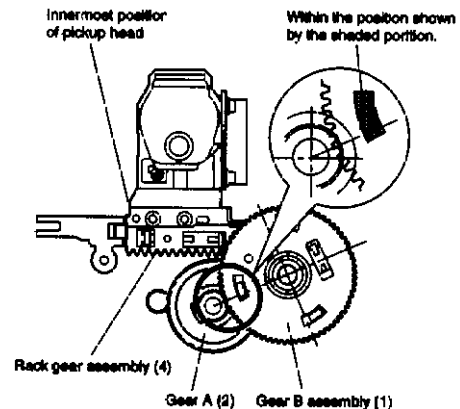

Fig. 2-1-22

1-4-6. Feed Motor

<Removal>

1. Remove the gear B assembly (1) and the gear A (2).
2. Remove two screws (1) and remove the feed motor (2) (with the feed motor PC board (3) attached.)
3. Desolder the terminals of the feed motor (2) and remove the feed motor PC board (3).

<Mounting>

1. Tighten the feed motor (2) on the pickup mechanism assembly with two screws (1).
2. Insert the feed motor PC board (3) with the positioning pin on the chassis matched and solder the terminals.
3. Perform the reverse order of the removal.

Note:

- After mounting, put the lead wires through the notch of the pickup mechanism assembly.
- When replacing the loading motor, meet the polarity phase of the terminals.

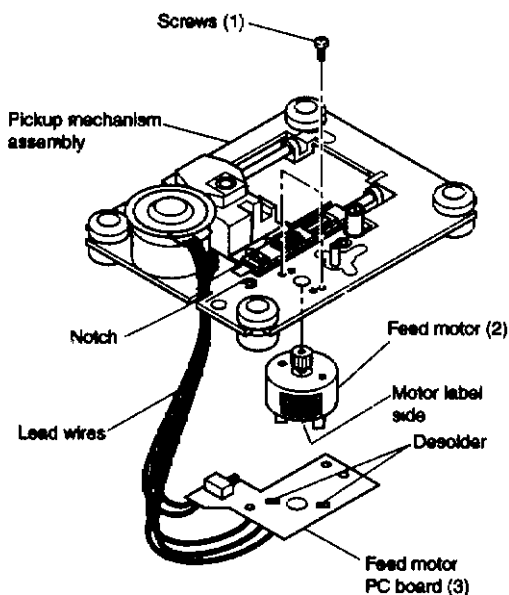

Fig. 2-1-23

1-4-7. Chucking Motor

1. Remove the mechanism chassis assembly. (Refer to item 1-3-4.)
2. remove the belt (1).
3. Remove one screw (2) and remove the pulley (3).
4. Remove one screw (4) and remove the loading gear.
5. Turn over the mechanism chassis assembly.
6. remove one screw (6).
7. De-solder and remove the chucking PC board (7).
8. Release two claws and remove the chucking motor (8).

Note:

When mounting, be sure to fix the cords with the cord clamps specified locations. (Refer to item 1-4-11).

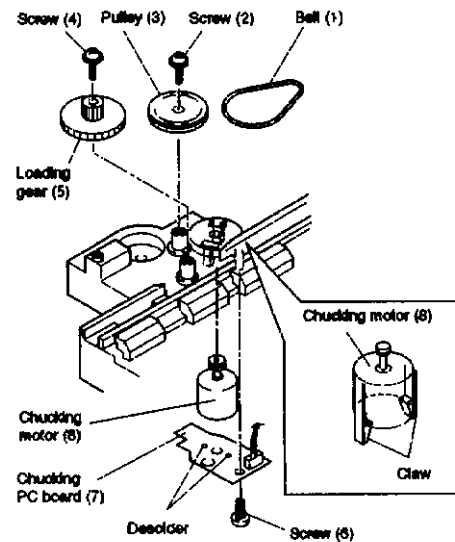

Fig. 2-1-24

1-4-8. Chucking sw PC Board

1. Remove the mechanism chassis assembly. (Refer to item 1-3-4).
2. Turn over the mechanism chassis assembly.
3. Remove one screw (1) and remove the chucking SW PC board (2).

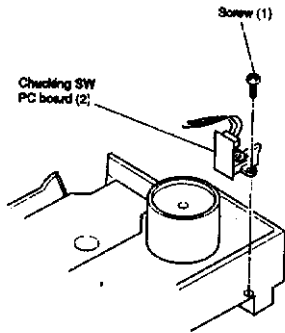

Fig. 2-1-25

1-4-9. Loading Motor PC Board

1. Remove the mechanism chassis assembly. (Refer to item 1-3-4).
2. Remove the belt (1).
3. Remove one screw (2) and remove the pulley (3).
4. remove one screw (4) and remove the cam gear (5).
5. Turn over the mechanism chassis assembly.
6. Remove one screw (6).
7. De-solder and remove the loading motor PC board (7).
8. Release two claws and remove the loading motor (8).

Note:

The cam gear (5) is divided in upper and lower sides by releasing two claws.

When mounting, be sure fix the cords with the cord clamps at specified locations. (Refer to item 1-4-11).

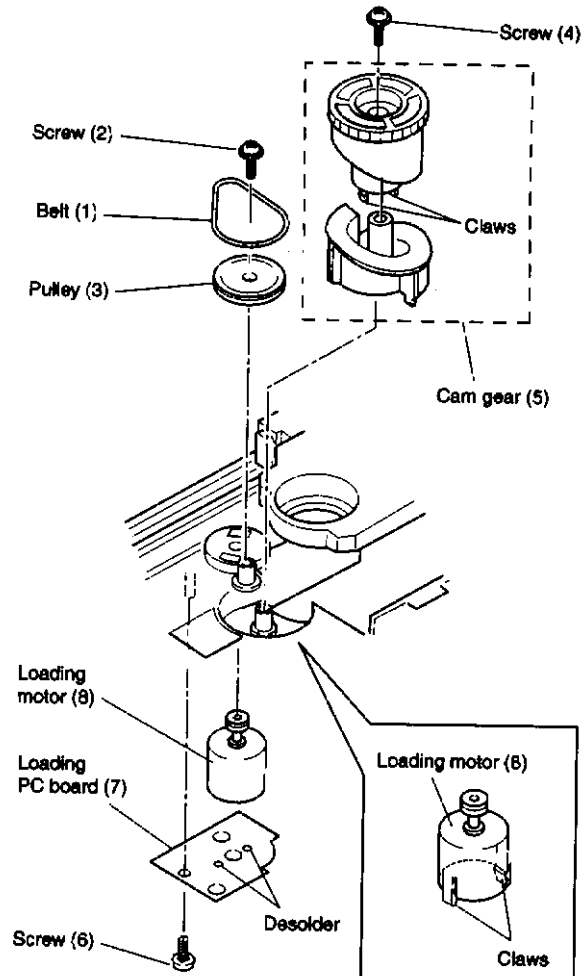

Fig. 2-1-26

1-4-10. Roulette IN/ OUT PC Board

1. Remove the tray rail. (Refer to item 1-3-4.)
2. Turn over the mechanism chassis assembly.
3. Remove one screw (1) and remove the roulette IN/ OUT PC board (2).

When mounting, be sure to fix the cords with the cord clamps at specified locations. (Refer to item 1-4-8.)

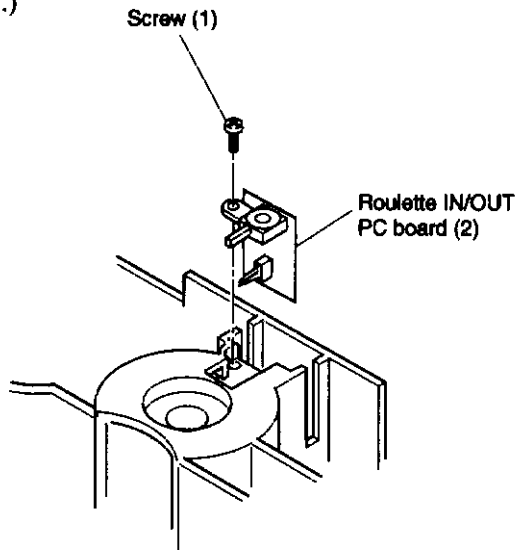

Fig. 2-1-27

1-4-11. Cord Wiring**Note:**

- When removing the PC boards located on the bottom side of the mechanism chassis, switches, etc., wire the cords shown in the figure below and fix with the cord clamps

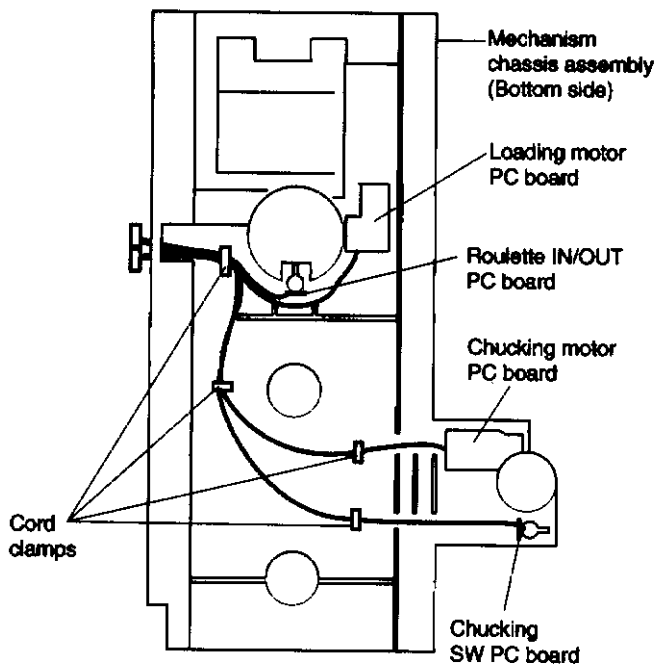

Fig. 2-1-28

REPLACEMENT OF OPTICAL PICKUP

The laser diode in the optical pickup block is so sensitive to static electricity, surge current and etc. That the components are liable to be broken down or its reliability remarkably deteriorated. During repair, carefully take the following precautions.
Do not touch the optical pickup object lens with the hands.

1. Remove the spacer on bottom side of the chassis. (Fig. A)
When replacing the optical pick up, first short J019 on Connector PC board(NAAR-3397).
2. Solder the LD terminal on the DVD mechanism.
(Fig. B)
3. Disconnect the flexible flat cable E101 and E103..
4. Replace the optical pickup.
5. Connect the flexible flat cable E101 and E103.
6. Unsolder the LD terminal on Mechanism.
(Fig. C)
7. Cutting the J019.

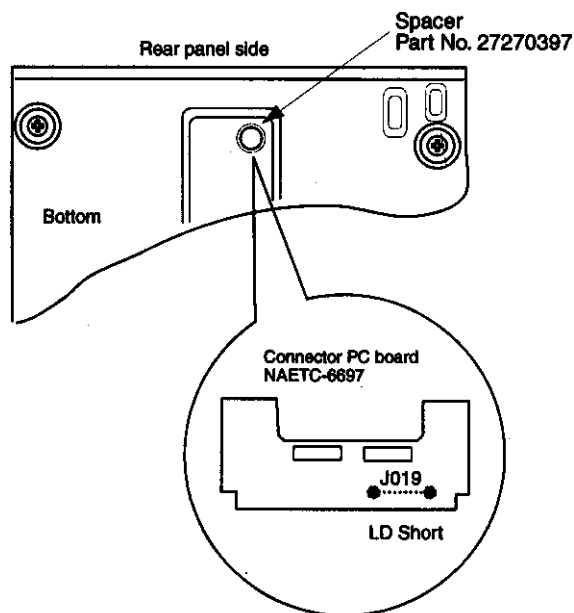

Fig. A

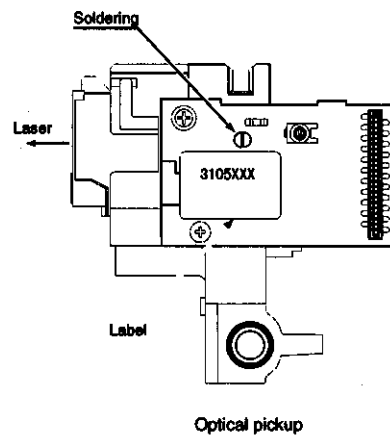

Fig. B

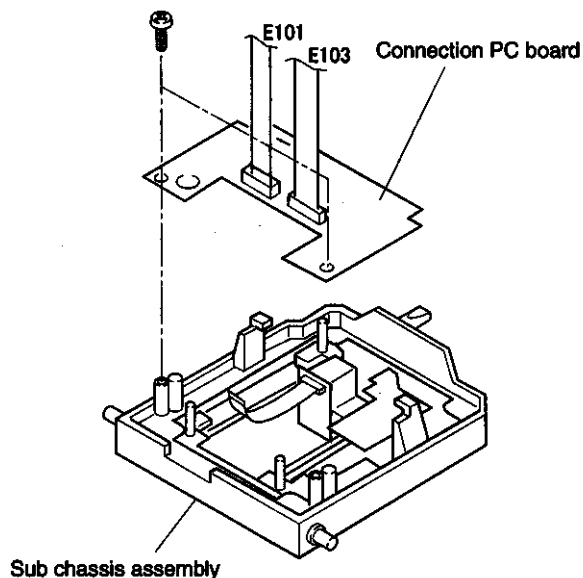
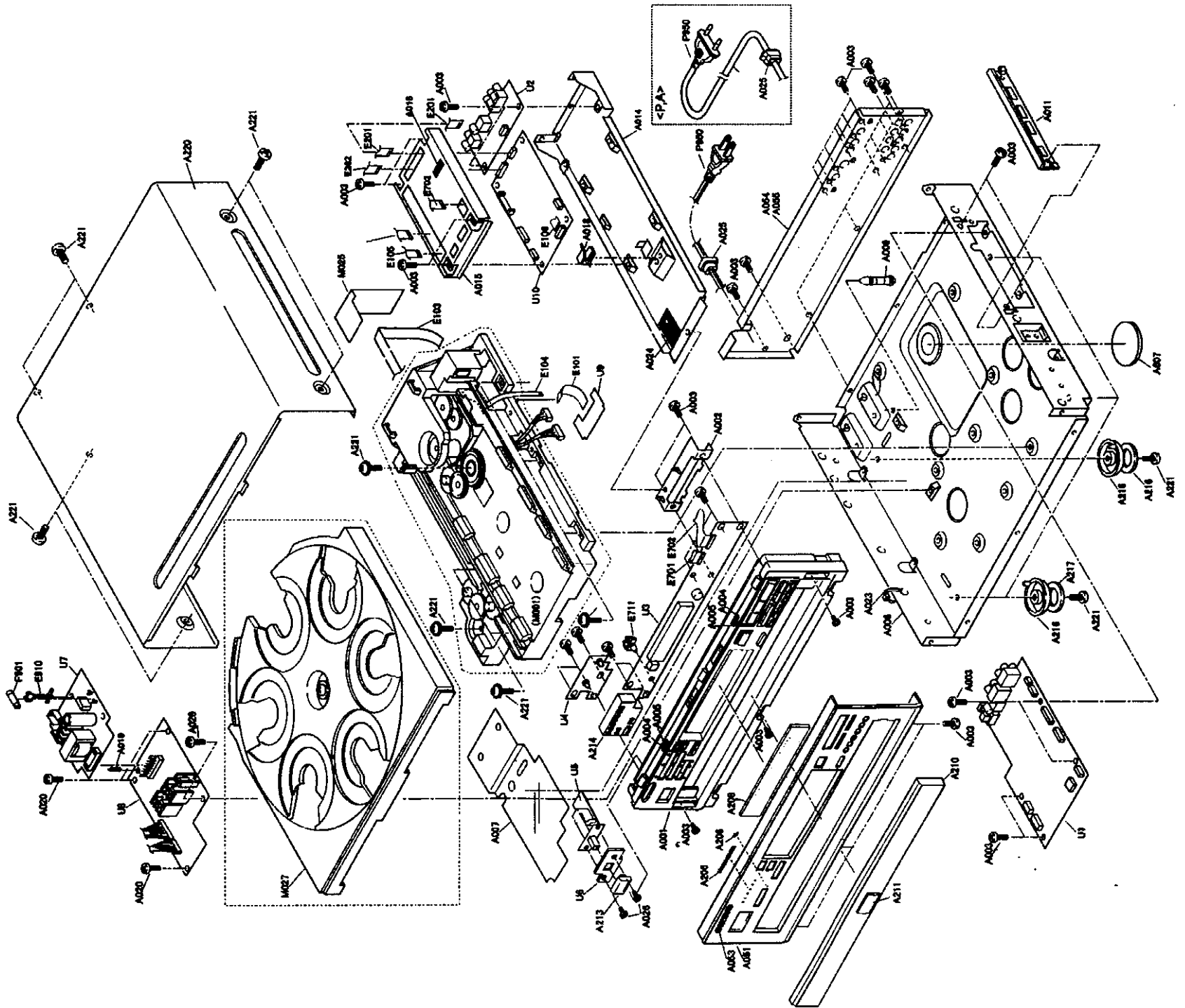
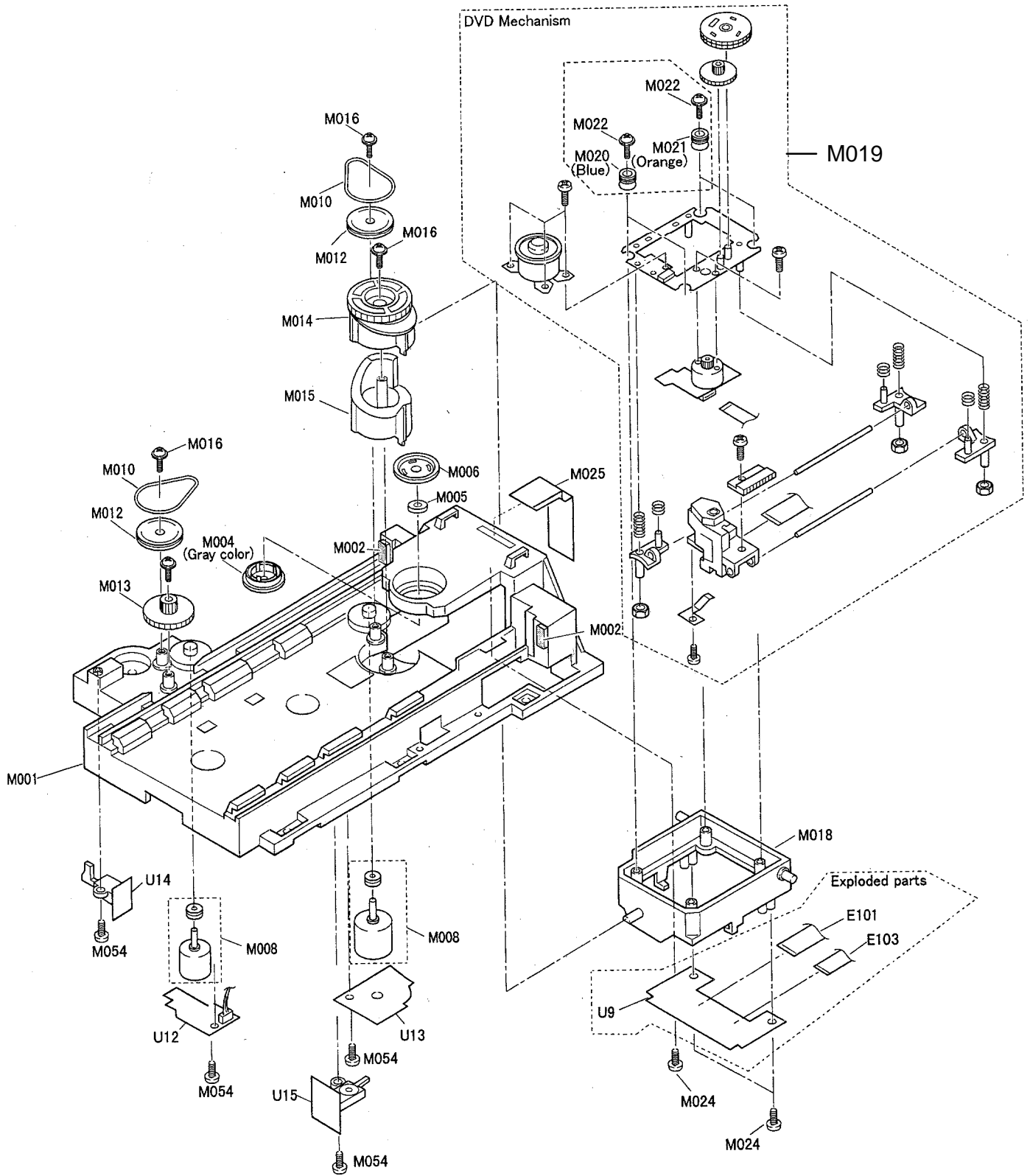

Fig. C

EXPLODED VIEW



MECHANICAL EXPLODED VIEW (1)



EXPLODED PARTS LIST

REF.NO.	PART NO.	DESCRIPTION
A001	27111129A	Front bracket
A002	27141746	Retainer F
A003	838130088	3TTB+8B,Self-tapping screw
A004	29110138	Tape, copper
A005	28141400	Cushion
A006	27100327B	Chassis
A007	28175252B	Isolated plate
A008	27190511	KGLS-16RF,Holder
A010	27191089	WLS-10-0,Holder
A011	27191084	Holder FFC
A014	27130828	Bracket PC
A015	27225143A	Shield case
A016	28141387	Cushion
A018	27191000Y	MFS-1000,Holder
A020	831430088	3TTW+8B(BC),Self-tapping screw
A023	260208	Wire tie
A024	29362285	Label
A025	△ 27300750	Bushing cord
A026	838430107	3TTB+10S(BC),Self tapping screw
A051	27212139	Front panel <P/A>
A051	27212124	Front panel <D>
A053	28135244Y	Badge
A054	27122634	Rear panel <D>
A055	27122666	Rear panel <A>
A055	27122635	Rear panel <P>
A205	28198896	Facet 6
A206	28198897	Facet 1
A208	28191858	Clear plate
A210	28148417A	Door
A211	27262641	Plate DVD
A213	28325465	Knob, POWER
A214	28325686	Knob ST
A216	27175316B	Leg
A217	28141332	Cushion for leg
A218	838130088	3TTB+8B,Tapping screw
A220	28184680A	Top cover
A221	838430088	3TTB+8B(BC),Self-tapping screw
A607	27270397Y	Spacer
E101	2042180512	NCFC2-180512,Flexible flat cable
E103	2042183512	NCFC3-183512,Flexible flat cable

REF.NO.	PART NO.	DESCRIPTION
E104	2042080812	NCFC2-080812,Flexible flat cable
E105	2045082012	NCFC5-082012,Flexible flat cable
E106	2046072022	NCFC6-072022,Flexible flat cable
E201	2045130512	NCFC5-130512,Flexible flat cable
E202	2044180122	NCFC4-180122,Flexible flat cable
E701	2045132512	NCFC5-132512,Flexible flat cable
E702	2045194512	NCFC5-194512,Flexible flat cable
E711	27190608-1	Holder
E801	260208	Wire tie
E910	27301396	HL-28-0,Clamper
F901	△ 252071	1.25A-SE-EAWK,Fuse <P/A>
F901	△ 252157	1.25A-UL/T-237,Fuse <D>
P950	△ 253193HIT or	AS-CEE or
P950	△ 253195MAR	AS CEE,Power supply cord <P/A>
P950	△ 253279HIT or	AS-UC-2#18 or
P950	△ 253280VOL	AS-UC-2#18,Power supply cord <D>
U1	1H412589-1A	NAAF-6689-1A,Output terminal PC board ass'y <D>
	1H412589-1B	NAAF-6689-1B,Output terminal PC board ass'y <P/A>
U2	1H412590-1A	NAAF-6690-1A,Video amplifier PC board ass'y <D>
	1H412590-1B	NAAF-6690-1B,Video amplifier PC board ass'y <P/A>
U3	1H412591-1A	NADIS-6691-1A,Display circuit PC board ass'y <D>
	1H412591-1B	NADIS-6691-1B,Display circuit PC board ass'y <P/A>
U4	1H412592-1A	NADIS-6692-1A,LED indicator PC board ass'y <D>
	1H412592-1B	NADIS-6692-1B,LED indicator PC board ass'y <P/A>
U5	1H412593-1A	NASW-6693-1A,Power switch PC board ass'y <D>
	1H412593-1B	NASW-6693-1B,Power switch PC board ass'y <P/A>
U6	1H412594-1A	NAETC-6694-1A,PC board ass'y <D>
	1H412594-1B	NAETC-6694-1B,PC board ass'y <P/A>
U7	1H412595-1A	NAPS-6695-1A,Power supply PC board ass'y (1) <D>
	1H412595-1B	NAPS-6695-1B,Power supply PC board ass'y (1) <P/A>
U8	1H412596-1A	NAPS-6696-1A,Power supply PC board ass'y (2) <D>
	1H412596-1B	NAPS-6696-1B,Power supply PC board ass'y (2) <P/A>
U9	1H412597-1A	NAETC-6697-1A,Connector PC board ass'y <D>
	1H412597-1B	NAETC-6697-1B,Connector PC board ass'y <P/A>
U10	24150011	SD-20D1, Main circuit PC board ass'y <D>
	24150012	SD-20E2,Main circuit PC board ass'y <P/A>

NOTE:

- <D>: 120V model only
- <P>: European model only
- <A>: Australian model only

MECHANICAL EXPLODED VIEW (2)

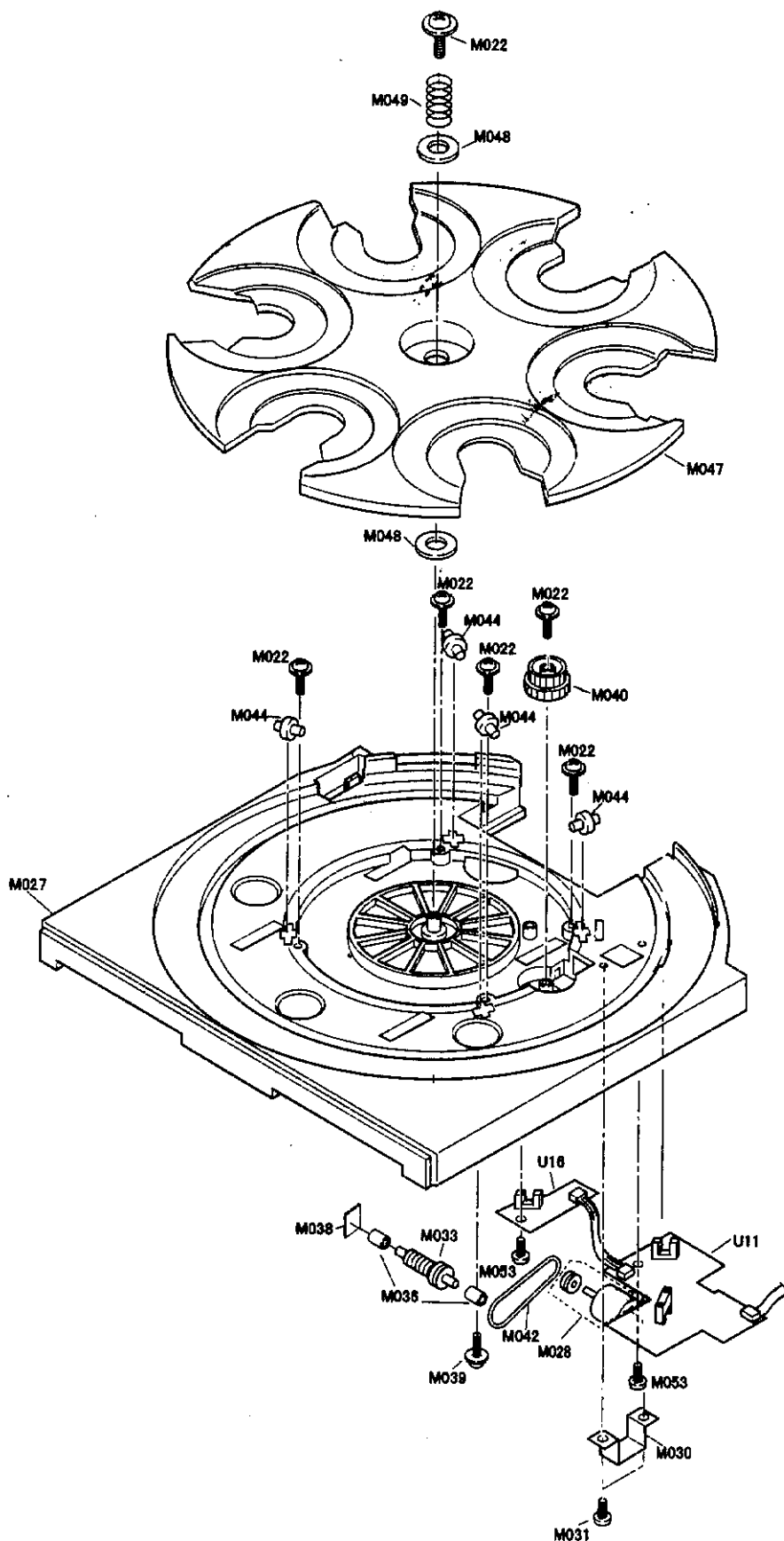

ROULETTE MECHANISM PARTS LIST

REF. NO.	PART NO.	DESCRIPTION	REF. NO.	PART NO.	DESCRIPTION
M001	24840109B	Rail	M036	24834017A	Spacer
M002	28141337Y	Cushion	M038	28141340Y	Cushion
M004	24824028	Cap CHD	M039	831430088	3TTW+8B(BC),Self-tapping screw
M005	24832028	Magnet CHC	M040	24810043Y	Gear, wheel
M006	24830028	Yoke CHC	M041	24840111	Special screw
M008	1H412901	RF-500TB-14415,Loading motor ass'y	M042	24816035	Rubber belt
M010	24816010AY	Rubber belt	M044	24840110Y	Roller
M012	24810040Y	Gear, pulley	M045	24840111	Special screw
M013	24810039A	Gear, load	M047	24840108A	Roulette
M014	24810041Y	Cam gear A	M048	24834016	Washer A
M015	24810042Y	Cam gear B	M049	24820033Y	Spring A
M016	831430088	3TTW+8B(BC),Self-tapping screw	M050	24840111	Special screw
M018	24802046A	Sub chassis	M053	838130088	3TTB+8B,Self-tapping screw
M019	24801003	SD-2109K1-ZX,DVD mechanism	M054	838426088	2.6TTB+8B(BC),Self-tapping screw
M020	24818013Y	Insulator A	U11	1H412554-2	NAETC-5854-2 Position Sensor PCB assy.
M021	24818014Y	Insulator B	U12	1H412555-2	NAETC-5855-2,Chucking motor PC board ass'y
M022	24840111	Special screw	U13	1H412556-2	NAETC-5856-2,Loading motor PC board ass'y
M024	838130088	3TTB+8B,Self-tapping screw	U14	1H412557-2	NASW-5857-2,Chucking switch PC board ass'y
M025	28175255	Isolated plate	U15	1H412558-2	NASW-5858-2,Roulette in/out PC board ass'y
M027	24840142	Tray	U16	1H412559-2	NAETC-5859-2,Disc sensor PC board ass'y
M028	1H412902	RF-310TA-11400,Roulette motor ass'y			
M030	24822018Y	Retainer			
M031	838130088	3TTB+8B,self-tapping screw			
M033	24810045A	Worm ass'y			

LOCATION OF MECHANISM PARTS

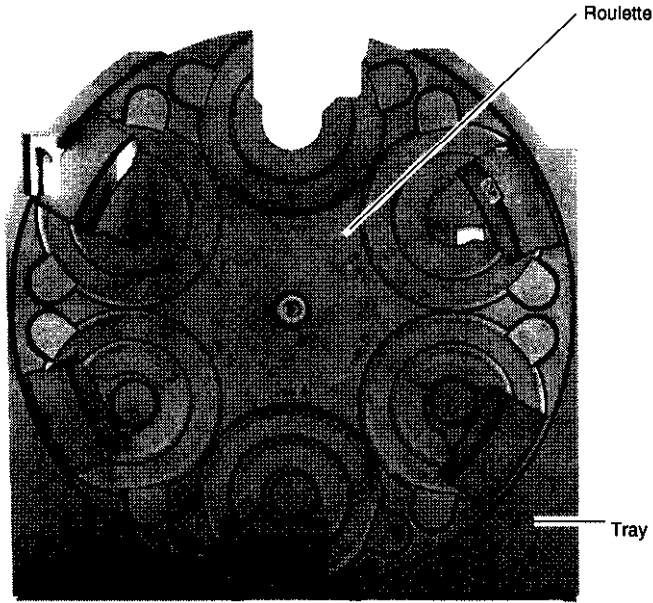

Mechanism chassis ass'y (Top side)

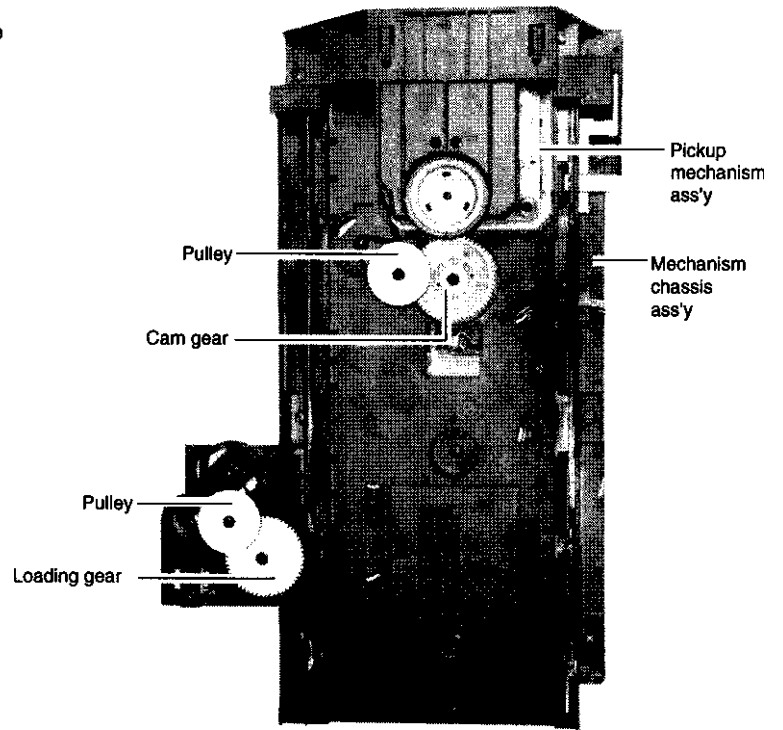

Mechanism chassis ass'y (Top side)

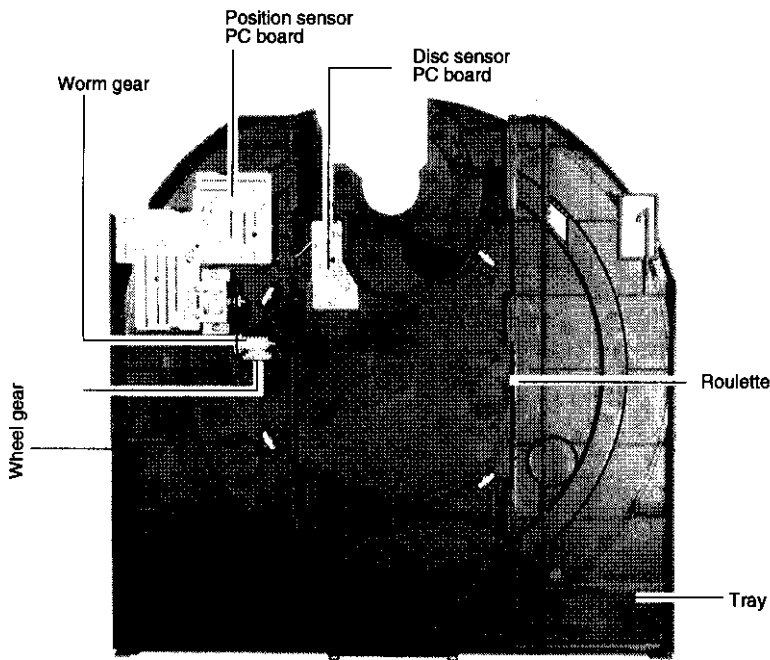

Mechanism chassis ass'y (Bottom side)

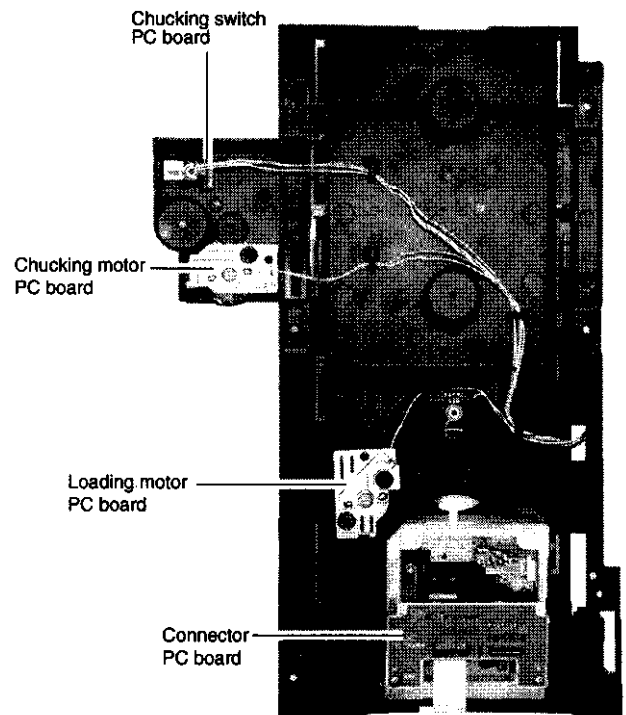

Mechanism chassis ass'y (Bottom side)

ELECTRICAL PARTS LIST

OUTPUT TERMINAL PC BOARD (NAAF-6689-1A/1B)			DISPLAY CIRCUIT PC BOARD (NADIS-6691-1A/1B)		
CIRCUIT NO.	PART NO.	DESCRIPTION	CIRCUIT NO.	PART NO.	DESCRIPTION
Q101-Q103	22240239	TA7291S	Q212,Q213	2213284 or	2SC1740S-R or
Q301	222740046R2	74HC004F		2215864	KTC3199-GR
Q401	22241383R1 or	NJM4565M-D or	Q217,Q220	2213284 or	2SC1740S-R or
	22241383R2	NJM4565M-D		2215864	KTC3199-GR <D>
	Transistors		Q218	2213354,	2SA933S-R,
Q104,Q410	221281 or	DTC114YS or		2213355 or	2SA933S-S or
	2213570	RN1207		2215995	KTA1267-GR <D>
Q105	2213354,	2SA933S-R,	Q221	2213354 or	2SA933S-R or
	2213355 or	2SA933S-S or		2213355	2SA933S-S
	2215995	KTA1267-GR		2215995	KTA1267-GR
Q403-Q406	2211705,	2SD655-E	Q230	2211705 or	2SD655-E or
	2211706 or	2SD655-F or		2211706	2SD655-F
	2216002	KTC2874-B		Diode	
Q411	2212600 or	DTA124ES or	D201	224490750R2	UD27.5B
	2215780	KRA103M		Coils	
	Photo coupler		L201	231253K100	NCH-1490
Q302	24120031	TOTX178A	L210	230921R2	BLM21B222SPT <D>
	Diodes		L211,L212	230921R2 or	BLM21B222SPT or
D101,	223233R1 or	1SS355 or		230952R2	BK2125LM182-T <D>
D401-D403	223234R2	1SS352	L213-L215	230921R2	BLM21B222SPT
	Coil		Z201,Z202	3030041	Y-5(8.00MHz)
L301	230921R2 or	BLM21B222SPT or	Z203,Z204	3030041	Y-5(8.00MHz)
	230952R2	BK2125LM182-T		Capacitors	
	Capacitors		C201	354744719	470 μ F,16V,Elect.
C101-C106	354744709	47 μ F,16V,Elect.	C211,C215	354744709	47 μ F,16V,Elect.
C303,C307	354721019	100 μ F,6.3V,Elect.	C222-C224	354724719	470 μ F,6.3V,Elect. <D>
C401,C402	374722224	2200pF \pm 5%,50V,Plastic	C225,C227	354724719	470 μ F,6.3V,Elect.
C403,C404	374724724	4700pF \pm 5%,50V,Plastic	C230	354744709	47 μ F,16V,Elect.
C407,C408	354782209	22 μ F,50V,Elect.		Terminals	
C409,C410	354744709	47 μ F,16V,Elect.	P201	25045546	NPJ-3PDRE367 <D>
C411,C412	354782209	22 μ F,50V,Elect.	P203	25045547	NPJ-1PDYE368
C421	354724719	470 μ F,6.3V,Elect.		Sockets	
	Resistor		P202	25051750	NSCT-4P1537
R108	453530474	4.7 Ω \pm 5%,1/2W,Metal	P212	25051765A	NSCT-13P1552
	Terminals			Plug	
P301	25045548	NPJ-1FDOR369	P211	25055146	NPLG-2P130
P310	25045330 or	NPJ-2PDBL184 or			
	25045481	NPJ-2PDBL299			
P401	25045371	NPJ-2PDWR214			
	Plugs				
P103A	25055149	NPLG-5P133			
P104A	25055150	NPLG-6P134			
	Sockets				
P113,P114	25051760A	NSCT-8P1547			
P115	25051851	NSCT-7P1638			
P210	25051777A	NSCT-25P1564			
P211A	2002A390420	NSAS-4P0754			
P302	2009990560UL	NSAS-4P0752 <D>			
P712B	25051771A	NSCT-19P1558			
VIDEO AMPLIFIER PC BOARD (NAAF-6690-1A/1B)					
CIRCUIT NO.	PART NO.	DESCRIPTION	CIRCUIT NO.	PART NO.	DESCRIPTION
	Transistors		Q703	212201	13-ST-40GNK
Q201,Q202	2213354 or	2SA933S-R or		IC	
Q205,Q206	2213355	2SA933S-S	Q701	22241389R3	MPD78042FGF-113-3B9
Q207,Q210,	2213284 or	2SC1740S-R or		Remote sensor	
Q211	2215864	KTC3199-GR <D>	Q705	24130011 or	PIC-12043TE2 or
Q214,Q215	2215995	KTA1267-GR <D>		241330	PIC-26043TE2
Q203,Q204	2213354 or	2SA933S-R or		Transistors	
Q208,Q209	2213355	2SA933S-S	Q702	2211504	2SA950-Y
Q216,Q219	2215995	KTA1267-GR	Q704	2212600 or	DTA124ES or
				2215780	KRA103M
				Diodes	
			D701	223233R1 or	1SS355 or
				223234R2	1SS352
			D702	224490560R2	UD25.6B
				Oscillator	
			X701	3010242	CST5.00MGW,Ceramic
				Capacitors	
			C701	354782209	22 μ F,50V,Elect.
			C702,C703	354721019	100 μ F,6.3V,Elect.
				Switches	
			S701-S719	25035652	NFS-111-S604

CIRCUIT NO.	PART NO.	DESCRIPTION	CIRCUIT NO.	PART NO.	DESCRIPTION	
	Sockets			Fuse holders		
P710	25051793A	NSCT-13P1580	F901A,F901B	25050065	YSH403T	
P712A	25051799A	NSCT-19P1586		Fuse label		
	Plug		E902	29361580	T1.25AL250V <P>	
P713A	25055152	NPLG-8P136		29362309	1.25A/125V <D>	
	Holder			Socket		
E710	27191085	(FL)	P920A	25051553	NSCT-12P1340	
	LED INDICATOR PC BOARD(NADIS-6692-1A/1B)			Plug		
	CIRCUIT NO.	PART NO.	DESCRIPTION	P950A	25055675	NPLG-2P631
Q707	222745955R2	74HC595F,IC		Heat sink		
D703	225255B	SEL3110S-B,LED	Q901A	27160412 or	RAD-111 or	
D704-D709	225324D	SEL6910A-D,LED		27160428	17PB23L30	
C704	355721019	100 μ F,6.3V,Elect. Capacitor		Cover		
S720	25035652	NPS-111-S604,Switch	C902A	27301216	SB1925A	
P713B	2002391615	NSAS-16P0194,Socket		Screw		
	POWER SWITCH PC BOARD (NASW-6693-1A/1B)		Q901B	838430107	3TTB+10S(BC),Self-tapping	
	CIRCUIT NO.	PART NO.	DESCRIPTION			
S990	△ 25035550	NPS-111-L512P,Switch		POWER SUPPLY CIRCUIT PC BOARD (2) (NAPS-6696-1A/1B)		
P912B	25055152	NPLG-8P136,Plug		CIRCUIT NO.	PART NO.	
C990	△ 3500077	DE7150F-472M,IS capacitor <P>	Q902	22241230	SI3090C	
	△ 3500196	RE275V-103M,IS capacitor <D>	Q903	22241231	SI3050C	
	POWER SUPPLY PC BOARD (1) (NAPS-6695-1A/1B)		Q904	22241232	SI3033C	
	CIRCUIT NO.	PART NO.	DESCRIPTION	Q905	22241233	SE005N
Q901	△ 22241229	STR-F6653		Transistors		
	IC		Q906,Q908	2211504	2SA950-Y	
Q907	24120044	ON3131-R	Q909,Q914	2213354 or	2SA933S-R or	
	Photo coupler			2213355 or	2SA933S-S or	
D901-D904	△ 22380287F	EM2A		2215995	KTA1267-GR	
D905	△ 22380291	EG01C		Diodes		
D906-D908	22380294	AG01Z	D909	22380295F	RN2Z	
	Power Transformer		D910,D911	22380296F	RK46	
T901	△ 2301432	NPT-1380	D912	22380297	EU01	
	Coil		D913,D921	22380294	AG01Z	
L901	△ 231280	NCH-3561	D917	22380300F	RU2YX	
	Core		D918	224473304	MTZ133D	
L903	△ 230906	BL02RN2-R62	D919	224470332	MTZ13.3B	
	Capacitors		D920,D923	22380032 or	1SR139-100 or	
C901,C902	△ 3500077	DE7150F-472M,IS		22380035 or	GP104003E or	
C910	△ 3500197 or	100 μ F,400V or		22380260	RL1N4003	
	△ 3937E1017	100 μ F,400V,Elect.	D922	224470753	MTZ17.5C	
C911	△ 3000115	DE1005SL-221J2K		Coils		
C912	△ 3000114	QXJ21-103K-TPT	L904-L907	231253K100	NCH-1490	
C913	354764709	47 μ F,35V,Elect.		Capacitors		
C916	△ 3300052	DE1610E 472M-KX,IS <P>	C920	393751027	1000 μ F,25V,Elect.	
	△ 3500077	DE7150F-472M,IS <D>	C921,C922	354744719	470 μ F,16V,Elect.	
	Resistors		C923,C924	354782209	22 μ F,50V,Elect.	
R901	△ 4500018 or	BPR58FK-0.22 or	C925,C928	393741027	1000 μ F,16V,Elect.	
	△ 4000076	MPC74-5WK-0.22,Metal plate <D>	C926,C927	354782209	22 μ F,50V,Elect.	
	△ 4500026	BPR58FK-1.00,Metal plate <p>	C929	374722244	0.22 μ F \pm 5%,50V,Plastic	
R902	△ 411566844	680k Ω \pm 5%,1/2W,Carbon	C930	354782209	22 μ F,50V,Elect.	
R903	△ 441726834NF	68k Ω \pm 5%,2W,Metal oxide	C931	354744719	470 μ F,16V,Elect.	
R904	△ 441721044NF	100k Ω \pm 5%,2W,Metal oxide	C932-C934	354782209	22 μ F,50V,Elect.	
R905	443523304	33 Ω \pm 5%,1/2W,Metal oxide	C935,C944	374721034	0.01 μ F \pm 5%,50V,Plastic	
R906	443522724	2.7k Ω \pm 5%,1/2W,Metal oxide	C936,C938	354782209	22 μ F,50V,Elect.	
R907	△ 451735194F	0.51 Ω \pm 5%,2W,Metal	C937	354761019	100 μ F,35V,Elect.	
R908	443526814	680 Ω \pm 5%,1/2W,Metal oxide	C941,C942	354761019	100 μ F,35V,Elect.	
R909	443523324	3.3k Ω \pm 5%,1/2W,Metal oxide	C943	354744709	47 μ F,16V,Elect.	
R910	443522234	22k Ω \pm 5%,1/2W,Metal oxide	C945,C946	354782209	22 μ F,50V,Elect.	

A B C D E F G
SCHEMATIC DIAGRAM

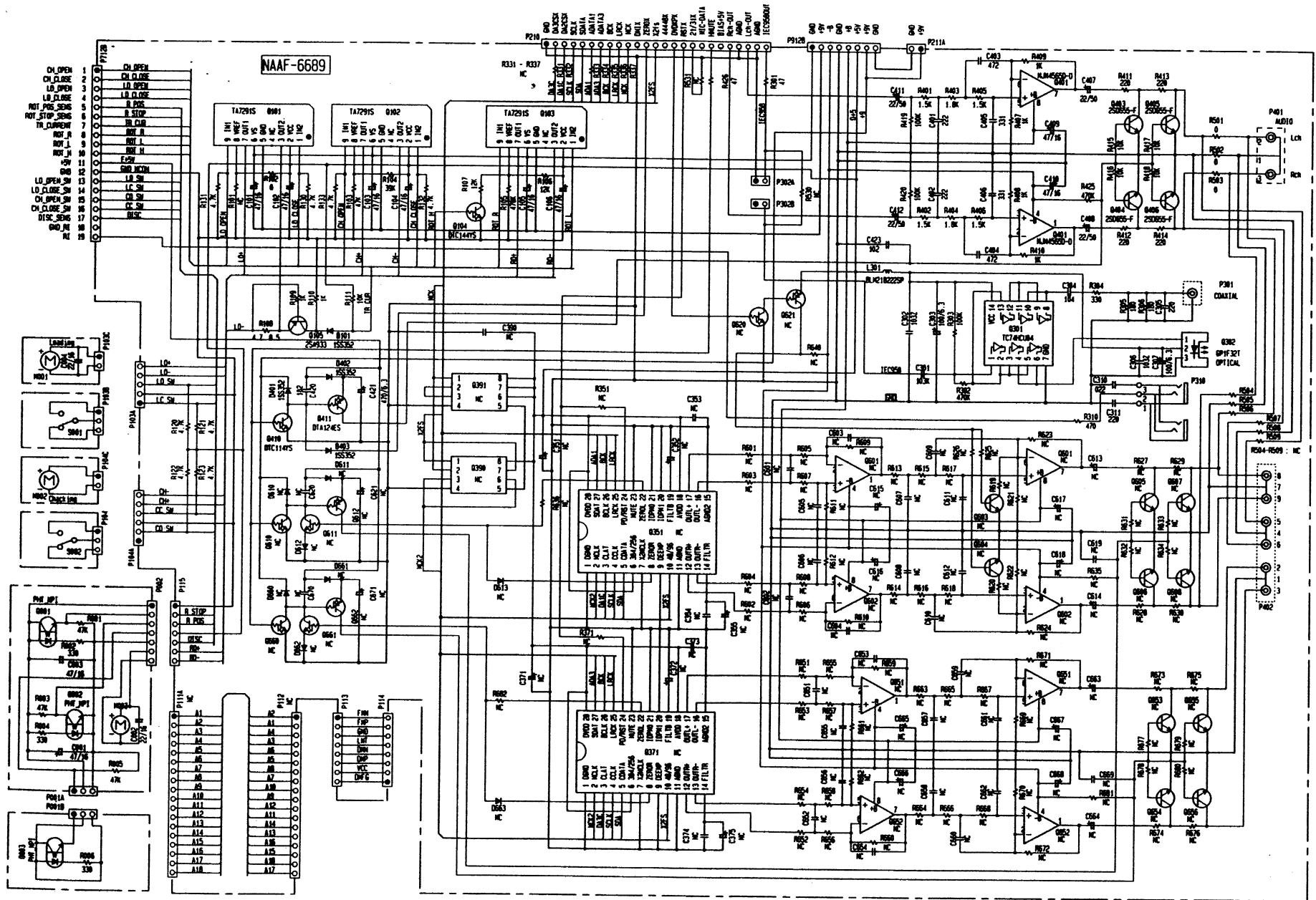

SCHEMATIC DIAGRAM

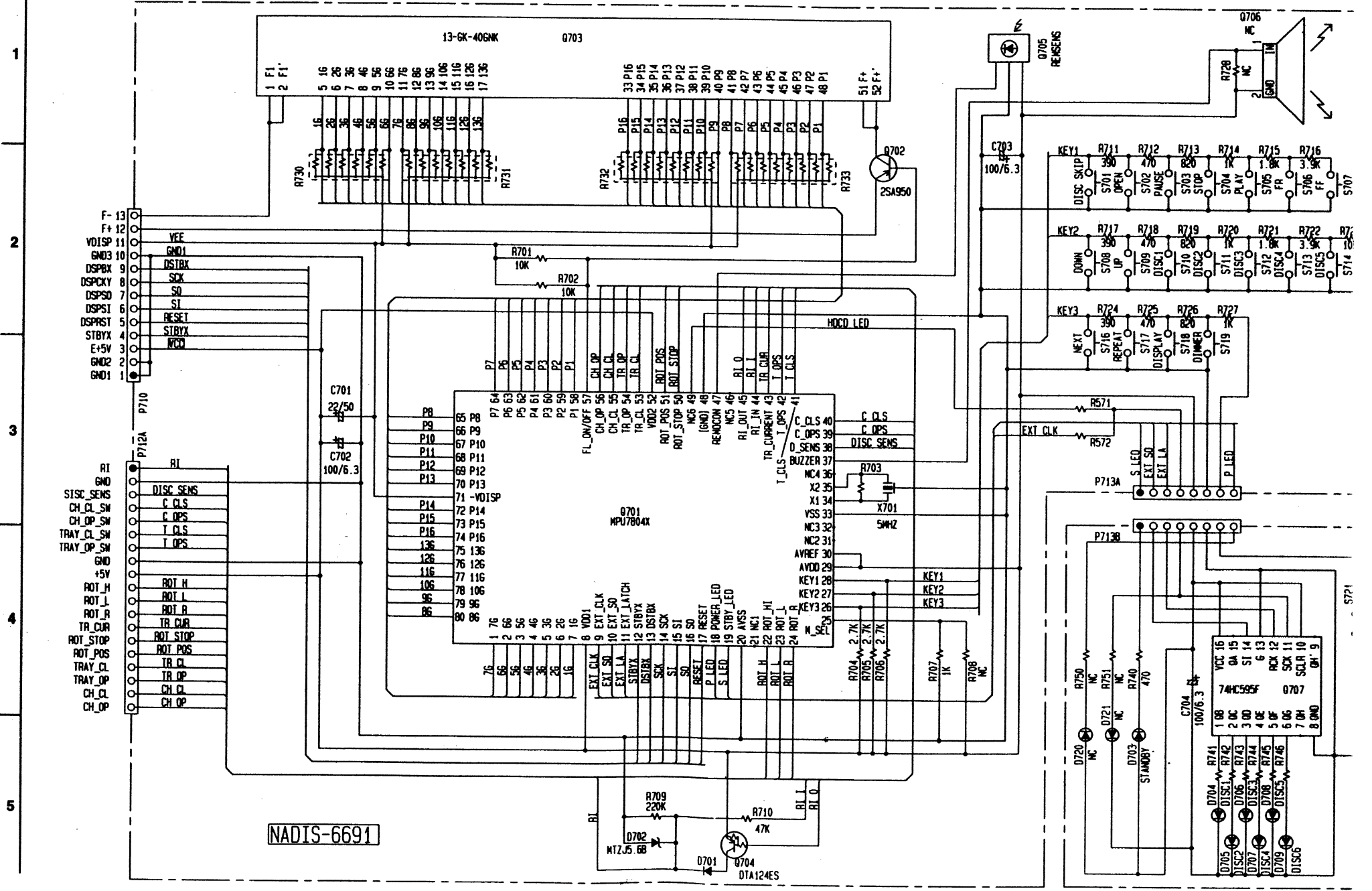

NADIS-6691

SCHEMATIC DIAGRAM

CAUTION

FOR CONTINUED PROTECTION AGAINST FIRE HAZARD, REPLACE ONLY WITH FUSE OF SAME TYPE AND RATING INDICATED.



THIS SYMBOL LOCATED NEAR THE FUSE INDICATES THAT THE FUSE USED IS SLOW OPERATING TYPE FOR CONTINUED PROTECTION AGAINST FIRE HAZARD, REPLACE WITH SAME TYPE FUSE. FOR FUSE RATING REFER TO THE MARKING ADJACENT TO THE SYMBOL.

ATTENTION

AFIN D'ASSURER UNE PROTECTION PERMANENTE CONTRE LES RISQUES D'INCENDIE, REMPLACER UNIQUEMENT PAR UN FUSIBLE DE MEME TYPE ET CALIBRATION COMME INDIQUE.



CE SYMBOLE INDIQUE QUE LE FUSIBLE UTILISE EST A LENT, E POUR UNE PROTECTION PERMANENTE, N'UTILISER QUE DES FUSIBLES DE MEME TYPE. CE DARNIER EST INDIQUE LA OU LE PRESENT SYMBOLE EST APPOSE.

1
2
3
4
5

NAPS-6696

NAPS-6695

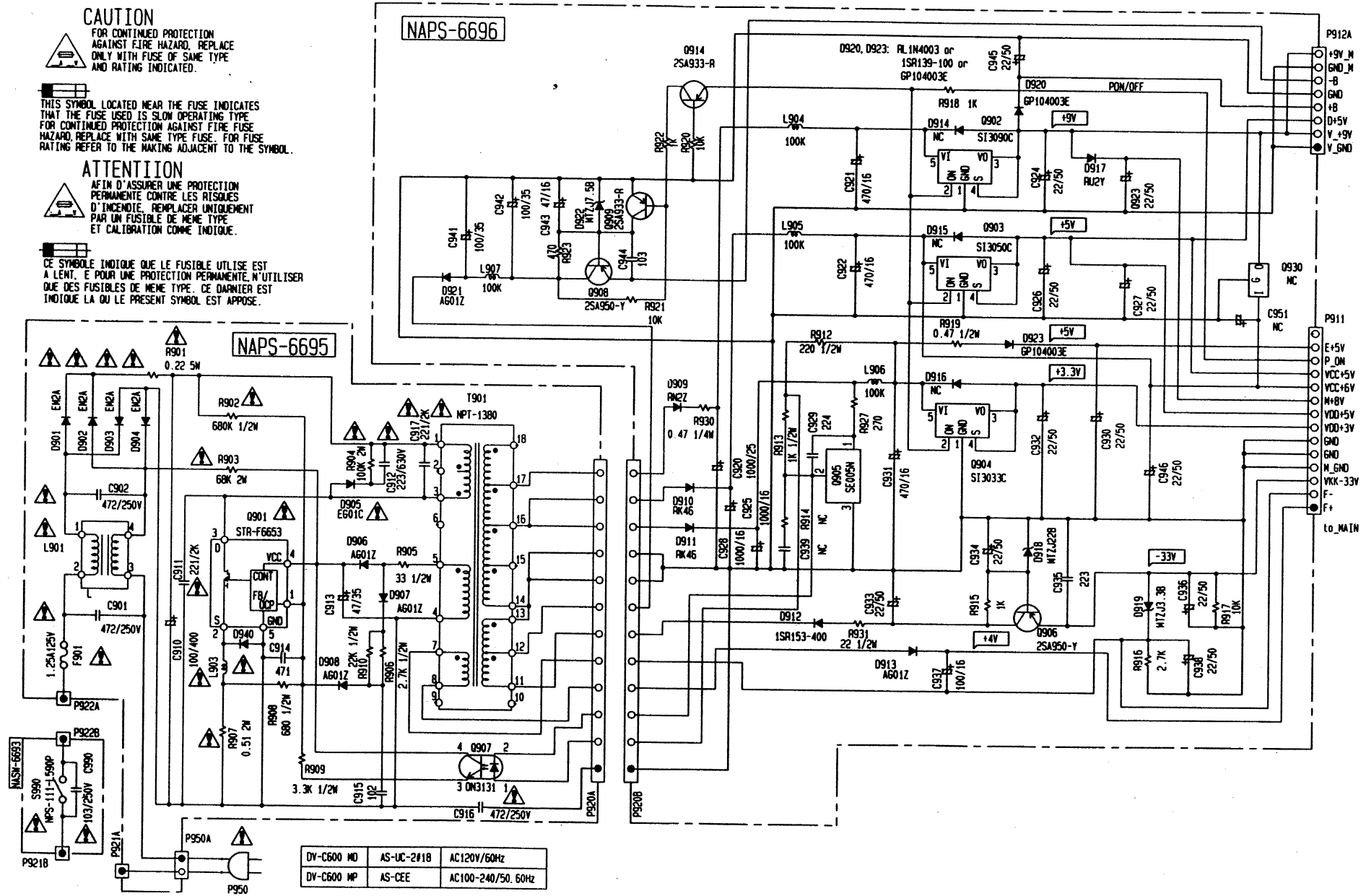

DV-C600 MD	AS-UC-2#18	AC120V/60Hz
DV-C600 MP	AS-CEE	AC100-240/50, 60Hz



SCHMATIC DIAGRAM

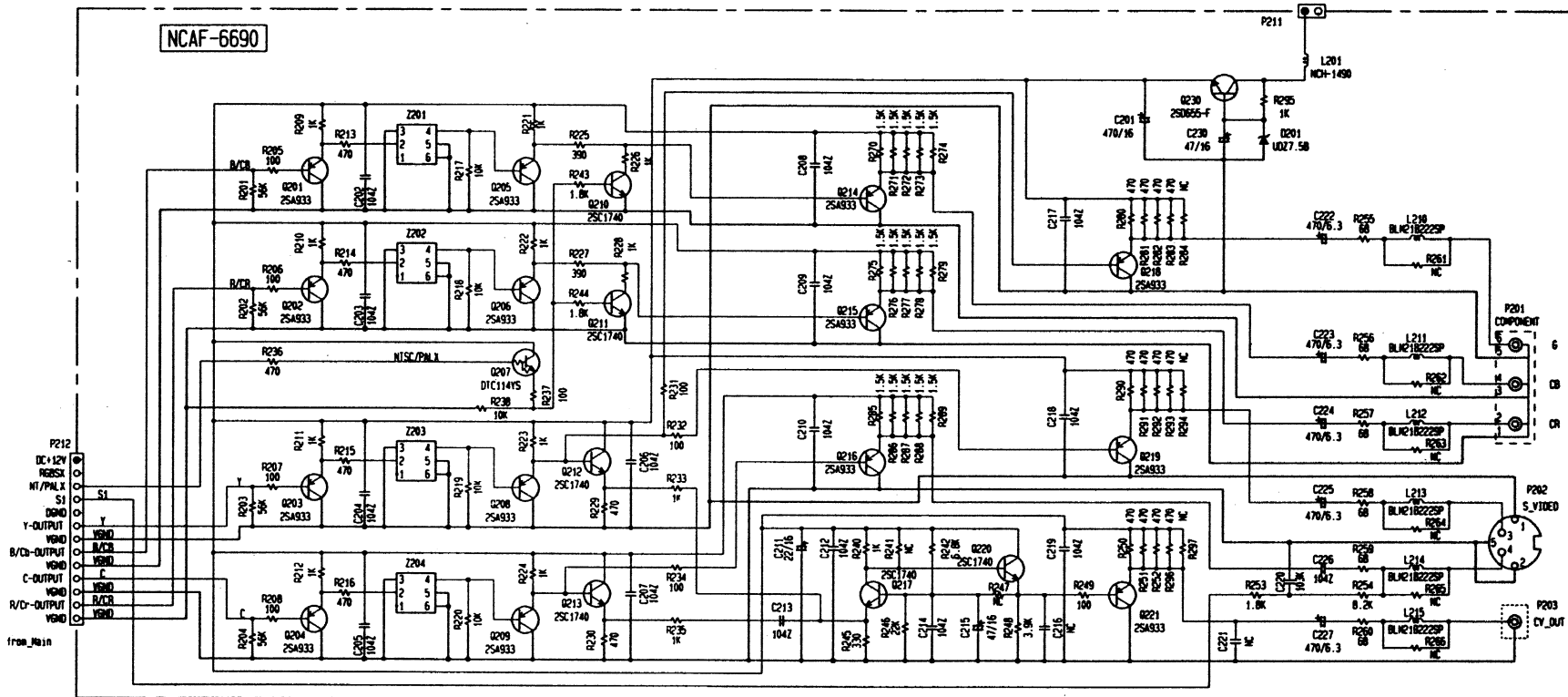

NOTE

- THE COMPONENTS IDENTIFIED BY MARK ARE CRITICAL FOR SAFETY. REPLACE ONLY WITH PART NUMBER SPECIFIED.
- VOLTAGE MEASURED WITH VOLTMETER (V) IS DC VOLTAGE, NO INPUT SIGNAL.
- ALL PNP TRANSISTORS ARE EQUIVALENT TO 2SC1015-OR UNLESS OTHERWISE NOTED.
- ALL NPN TRANSISTORS ARE EQUIVALENT TO 2SC1815-OR UNLESS OTHERWISE NOTED.
- ALL DIODES ARE EQUIVALENT TO 1SS133 UNLESS OTHERWISE NOTED.
- ELECTROLYTIC CAPACITORS () ARE IN μ F/V.
- ALL CAPACITORS ARE IN pF/500V UNLESS OTHERWISE NOTED.
- EX1 0.30-30F 330-330F 331-8300F 333-0.0330F
- ALL RESISTORS ARE IN OHMS Ω /MILLIS UNLESS OTHERWISE NOTED.
- THE THICK LINES ON PC BOARD ARE THE PRINTING SIDE OF THE PARTS.
- EX1 PRINTING SIDE
- CIRCUIT IS SUBJECT TO CHANGE FOR IMPROVEMENT.

ELECTRICAL PARTS LIST

CIRCUIT NO.	PART NO.	DESCRIPTION
	Resistors	
R912	443522214	220 Ω \pm 5%, 1/2W, Metal oxide
R913	443521024	1k Ω \pm 5%, 1/2W, Metal oxide
R919	453534794	0.47 Ω \pm 5%, 1/2W, Metal
R930	4500163	0.47 Ω \pm 5%, 1/4W, Metal
R931	443522204	22 Ω \pm 5%, 1/2W, Metal oxide
	Sockets	
P912A	2002A391665	NSAS-16P0765
P911	2002A392855	NSAS-28P0766
	Plug	
P920B	25055853	NPLG-12P809
	Heat sinks	
Q902A	27160145-1	RAD-51
Q903A, Q904A	27160176	
	Screws	
Q902B-Q904B	838430107	3TTB+10S(BC)

NOTE:

THE COMPONENTS IDENTIFIED BY MARK Δ ARE CRITICAL FOR RISK OF FIRE AND ELECTRIC SHOCK. REPLACE ONLY WITH PART NUMBER SPECIFIED.

NOTE:

<D> : 120V model only

<P/A> : European and Australian models only

MECHANISM SECTION PC BOARD-PARTS LIST

CIRCUIT NO.	PART NO.	DESCRIPTION
	Capacitors	
C001, C003	354744709	47 μ F, 16V, Elect.
C002, C004	352942206	22 μ F, 16, Elect., Non-polar
	Sockets	
P001A	2002390605UL	NSAS-6P0597
P104	2009990446UL	NSAS-11P0595
P103	2009990447UL	NSAS-10P0596
	Photo interrupters	
Q001, Q003	24190041	SG-207
Q002	24190046	GP2S28
	Socket	
P105B	25050913,	NSCT-7P700,
	25051851Y or	NSCT-7P1638 or
	25052053	NSCT-7P1840
	Plug	
P001B	25055367	NPLG-3P350
	Switches	
S001	25065491	NMS-1223
S002	25065375	NMS-1219

MICROPROCESSOR TERMINAL DESCRIPTION

Q701: μ PD78042PGF

PIN No.	TERMINAL	NO	DESCRIPTION
1	FIP_7G	0	Grid output pins.
2	FIP_6G	0	Grid output pins.
3	FIP_5G	0	Grid output pins.
4	FIP_4G	0	Grid output pins.
5	FIP_3G	0	Grid output pins.
6	FIP_2G	0	Grid output pins.
7	FIP_1G	0	Grid output pins.
8	+5V		Power supply pin(+VDD)
9	EXT_CLK/HDCD	0	Command data output terminal for microprocessor. To connect to the SCK terminal of 74HC595.
10	EXT_S0	0	Command data output terminal for microprocessor. To connect to the SER terminal of 74HC595.
11	EXT_LATCH	0	Command data output terminal for microprocessor. To connect to the SCK terminal of 74HC595.
12	TSB_STBYX	0	Sleeve reset output terminal from main microprocessor.
13	TSB_DSTRX	1	Strobe data input terminal from main microprocessor.
14	TSB_SCK	1	Serial clock input terminal from main microprocessor.
15	TSB_S1	0	Serial data output terminal to main microprocessor.
16	TSB_S0	1	Serial data input terminal from main microprocessor.
17	-RESSET	1	System reset input terminal.
18	POWER_LED	0	Power LED control output terminal.
19	STBY_LED	0	Standby LED control output terminal.
20	GND		Ground terminal for A/D converter.
21	MONITOR_2	0	Monitor terminal for checking the microprocessor
22	ROT_HI	0	Roulette control output terminal.
23	ROT_L	0	Roulette control output terminal.
24	ROT_R	0	Roulette control output terminal.
25	MAKER_SELECT	1	Maker select analog input terminal.
26	KEY3	1	Key input terminal.
27	KEY2	1	Key input terminal.
28	KEY1	1	Key input terminal.
29	+5V		Power supply terminal of the A/D converter.
30	+5V		Reference power supply terminal of the A/D converter.
31			Not used.
32			Not used.
33	GND		Ground terminal.
34	X1		Connect 5MHz ceramic resonator across the terminal X1 and X2.
35	X2		Ceramic oscillator connection for main system clock.
36	MONITOR_3	0	Monitor terminal for checking the microprocessor
37	BUZZER	0	Buzzer signal output terminal.
38	DISC_SENSE_IN	1	Connect to the photo-sensor of reelless
39	CH_CLOSE_IN	1	Checking control input signal (Close)
40	CH_OPEN_IN	1	Checking control input signal (Open)
41	TRAY_OPEN_IN	1	Detection input terminal for tray open switch
42	TRAY_CLOSE_IN	1	Detection input terminal for tray close switch
43	TRAY_CURRENT_IN	1	Detection input signal of overcurrent for loading motor
44	RI_IN	1	Input terminal of the RI signal
45	RI_OUT	0	Output terminal of the RI signal
46	MONITOR_1	0	Monitor terminal for checking the microprocessor
47	REMOCON_IN	1	Remote control input signal
48	IC		Connect to the ground terminal
49	EXT_O	0	Open terminal
50	ROT_STOP_IN	1	Detection input terminal of the carousel rotation
51	ROT_POS_IN	1	Detection input terminal of the carousel position
52	+5V		Power supply (+5V)
53	TRAY_CLOSE_OUT	0	Output control signal for closed of tray
54	TRAY_OPEN_OUT	0	Output control signal for opened of tray
55	CH_CLOSE_OUT	0	Checking close detection output terminal
56	CH_OPEN_OUT	0	Checking open detection output terminal
57	FL_CONTROL	0	FL tube control output terminal
58	FIP_P1	0	Segment output terminals.
59	FIP_P2	0	Segment output terminals.
60	FIP_P3	0	Segment output terminals.
61	Vfwd		Power supply terminal for FL tube
62	FIP_P14	0	Segment output terminals.
63	FIP_P15	0	Segment output terminals.
64	FIP_P16	0	Segment output terminals.
65	FIP_13G	0	Grid output pins.
66	FIP_12G	0	Grid output pins.
67	FIP_11G	0	Grid output pins.
68	FIP_10G	0	Grid output pins.
69	FIP_9G	0	Grid output pins.
70	FIP_8G	0	Grid output pins.

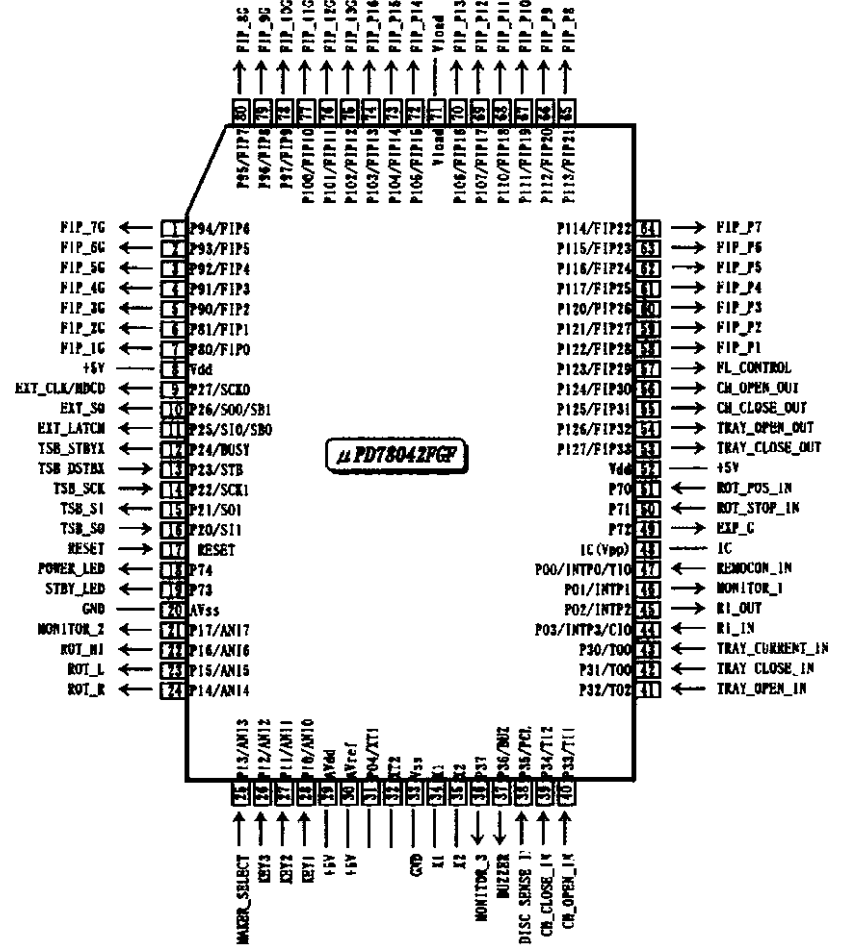

TROUBLESHOOTING
SERVO SYSTEM

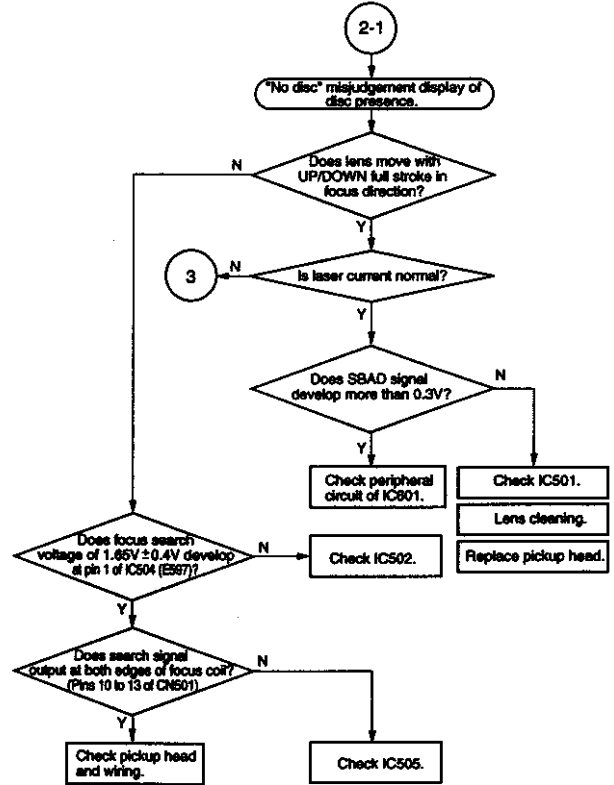
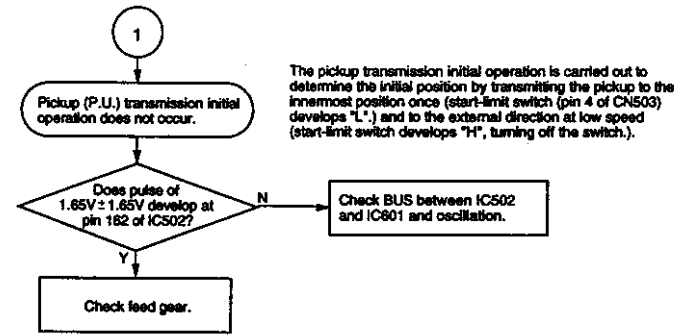
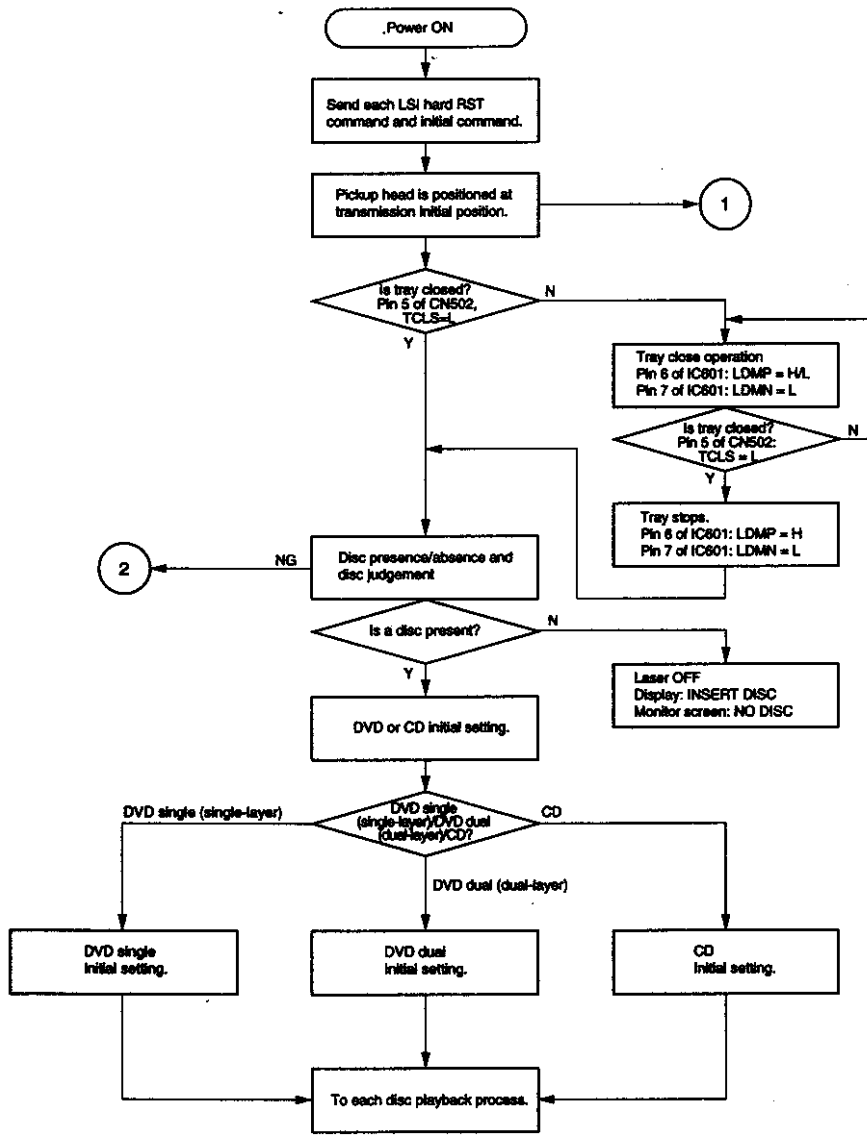

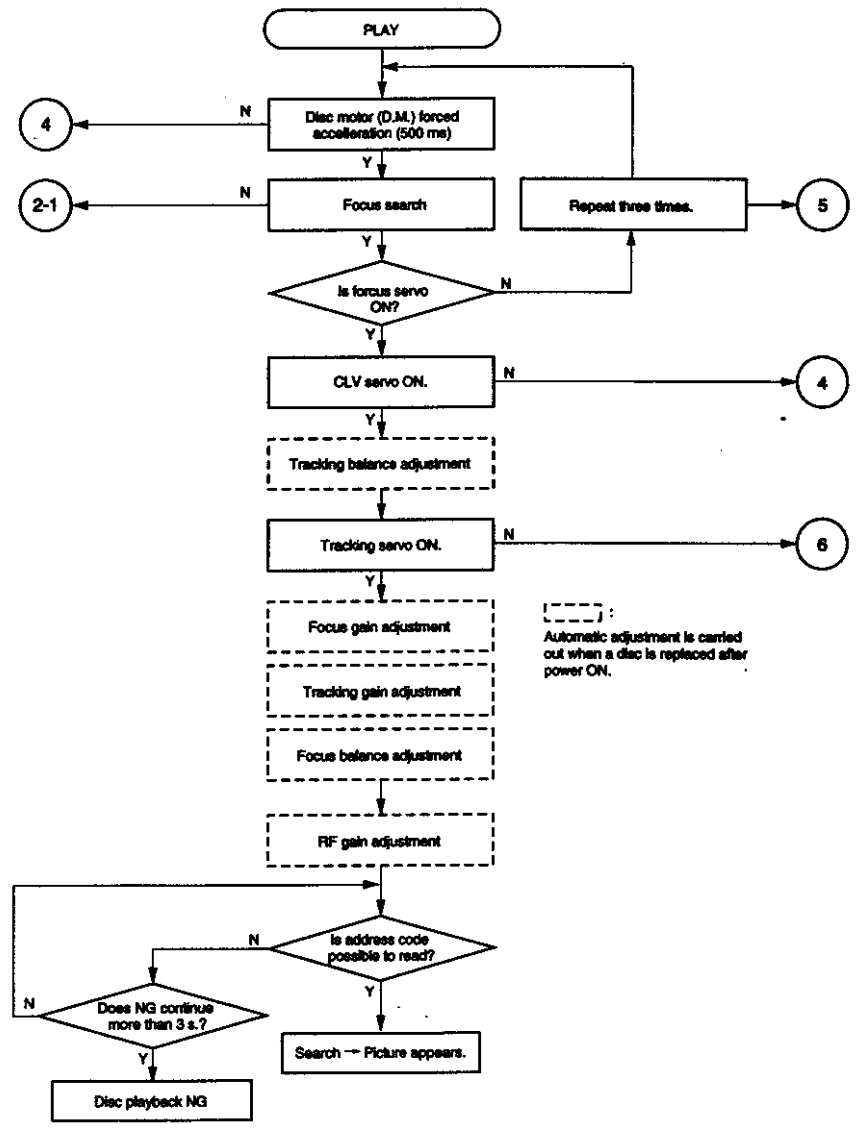
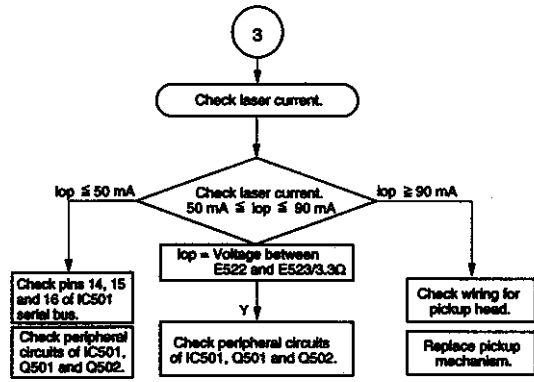
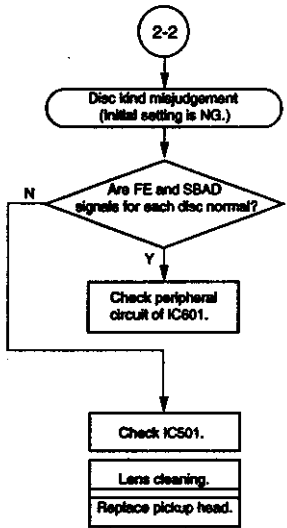

DVD single (single-layer) disc detection waveform

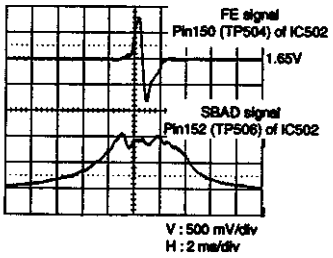

DVD dual (dual-layer) disc detection waveform

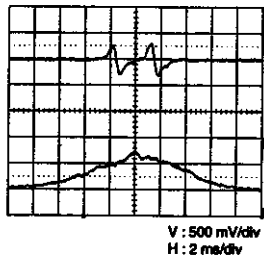

CD disc detection waveform

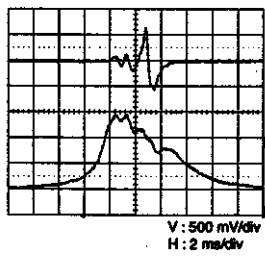

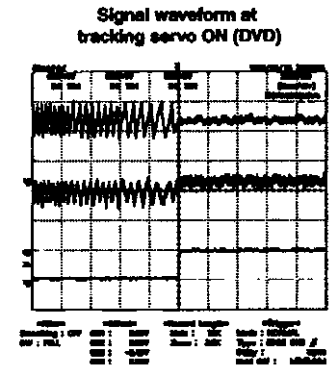
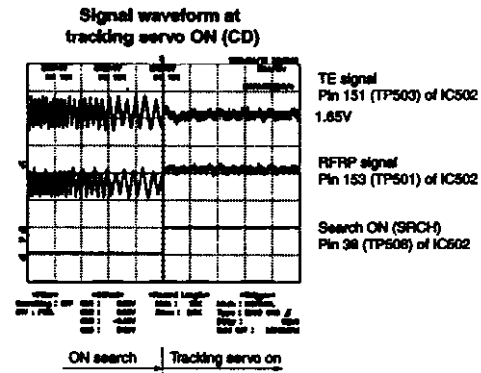
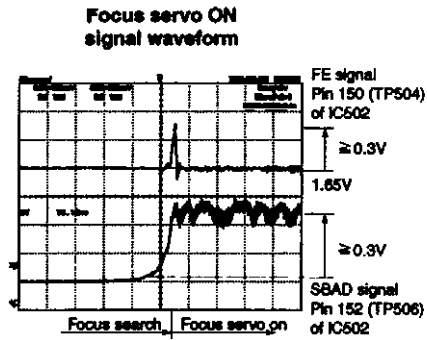
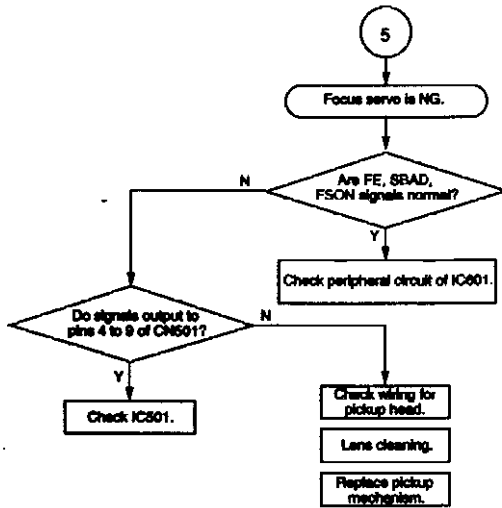
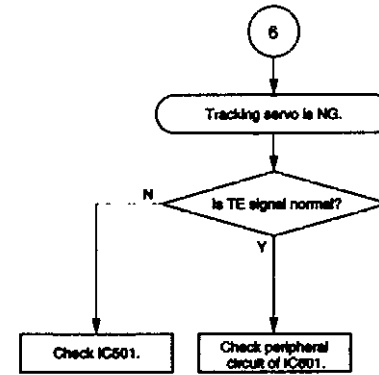
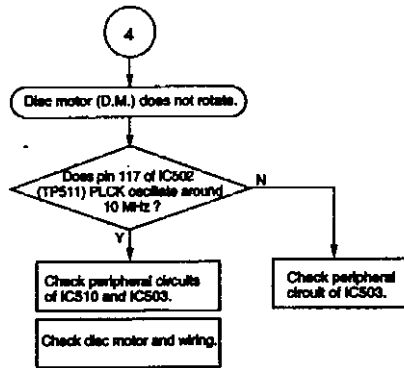

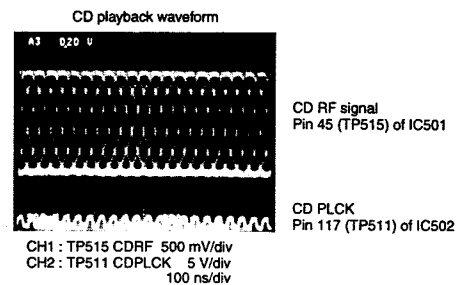
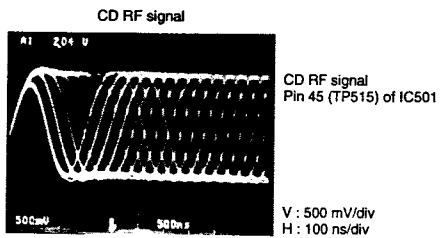
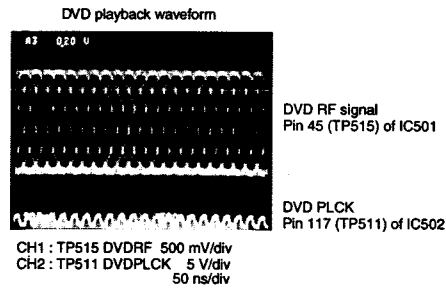
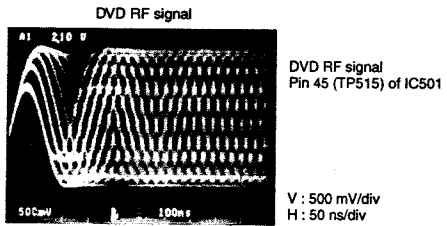
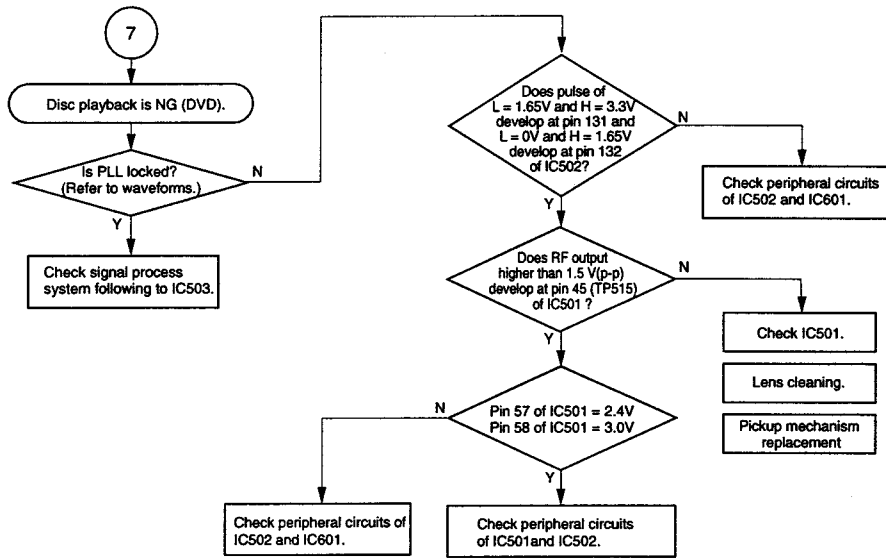

LOCATION DIAGRAM OF SERVO TEST POINT

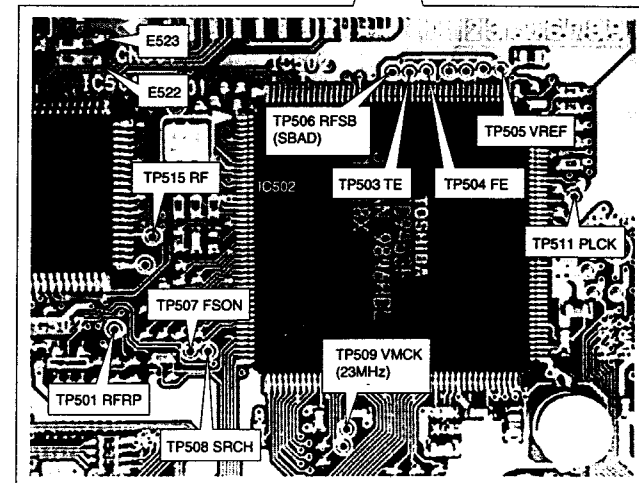
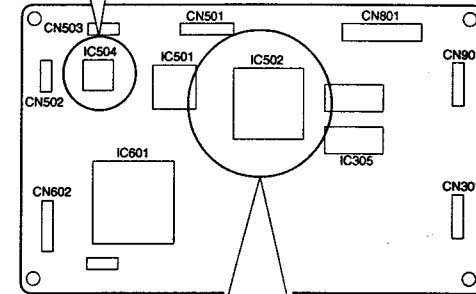
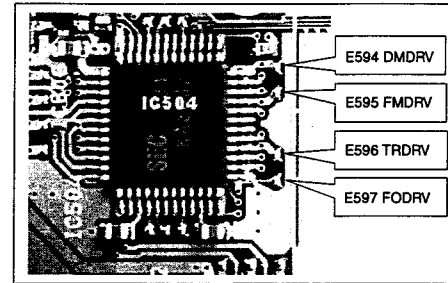

MECHANISM ASSEMBLY

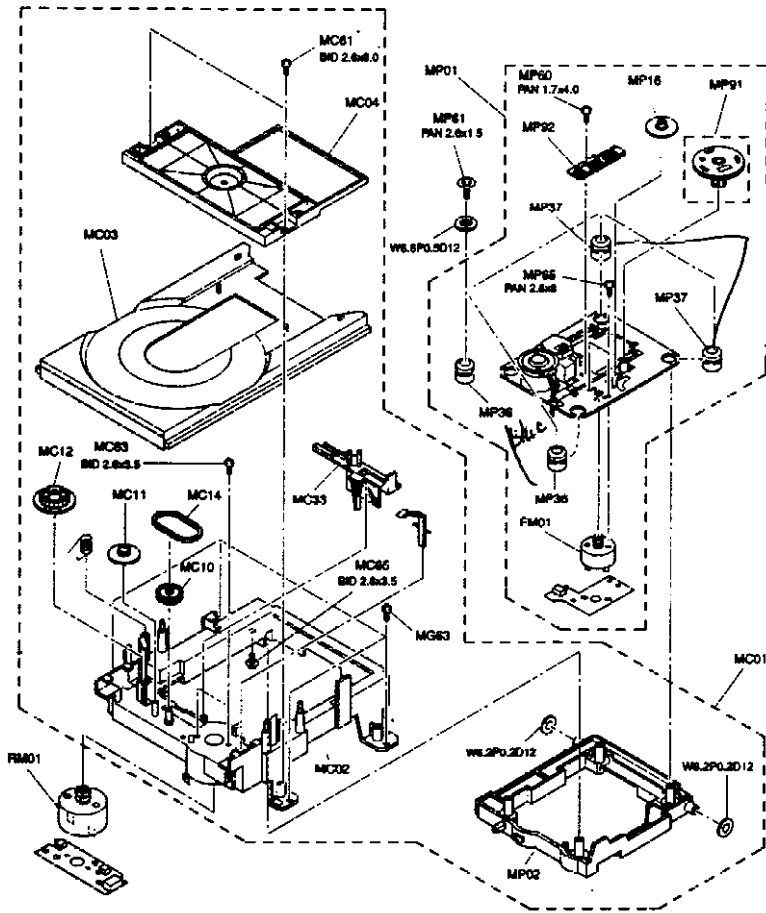

MECHANICAL PARTS LIST

REF. No.	PART No.	DESCRIPTION
MP01	79070415	MECHA ASSY-PUI
MP36	79070417	RUBBER, DUMPER, FRONT
MP37	79070418	RUBBER, DUMPER, REAR
MP91	79070419	GEAR ASSY, KIT, B
MP92	79070420	GEAR ASSY, RACK
FM01	79070421	MOTOR ASSY, FEED, DC
MP16	79070422	GEAR A
RM01	79070427	MOTOR ASSY, LOADING, DC
MC14	79070428	BELT, LOAD
MC01	79070416	CHASSIS ASSY, MECHANISM

PARTS LIST (Main PC board)

LOCATION No.	PART No.	DESCRIPTION	LOCATION No.	PART No.	DESCRIPTION				
Integrated circuits									
IC201	NSP	79040154	IC	TC203G08AF-0103(Z)	IC616	NSP	79040007	IC	TC7S08F
IC202	NSP	79010145	IC	NN514800AJ-G0T	IC617	NSP	79040087	IC	TC7W241FU
IC301	NSP	79040122	IC	MD36710X	IC901	NSP	79040151	IC	PCM1727E
IC302	NSP	79040063	IC	HY57V16160ATC-10	IC902	NSP	79040119	IC	TC7SH86F
IC305	NSP	79040063	IC	HY57V16160ATC-10	IC903	NSP	79040102	IC	NJM2370U50
IC306	NSP	79040096	IC	ADV7170KS	IC904	NSP	79040087	IC	TC7W241FU
IC307	NSP	79040130	IC	NJU6321PE-TE1	Transistors				
IC308	NSP	79040011	IC	TC7W04F	Q501	NSP	79050036	Transistor, Chip	2SA1832-GR
IC311	NSP	79040013	IC	TC7W74F	Q502	NSP	79050042	Transistor, Chip	2SC2883-Y
IC312	NSP	79040119	IC	TC7SH86F	Q503	NSP	79050014	Transistor, Chip	HN1C03F
IC313	NSP	79040119	IC	TC7SH86F	Q601	NSP	79050031	Transistor, Chip	DTA114EKA
IC314	NSP	79040119	IC	TC7SH86F	Miscellaneous				
ICS01	NSP	79040152	IC	TA1293F	X301	NSP	79089003	Oscillator	SMD49.27MHz
ICS02	NSP	79040149	IC	TC9453F	X501	NSP	79089021	Ceramic Oscillator	22.58MHz
IC503	NSP	79040148	IC	V53C16128HK-30	X601	NSP	79089022	Ceramic Oscillator	9.00MHz
IC504	NSP	79040150	IC	KA3032	EU01				
IC506	NSP	79040006	IC	TC7S04F	79083019	PC Board Assy	Main PCB		
IC508	NSP	79040066	IC	UPC291.33T	NSP : Not spare part				
IC601	NSP	79040158	IC	TMP94CS40AF-4401					
IC602	NSP	79040041	IC	PST591-IDT					
IC607	NSP	79040007	IC	TC7S08F					
IC613	NSP	79040070	IC	S-2401AFJ-TB					
IC614	NSP	79040148	IC	V53C16128HK-30					
IC615	NSP	79040153	IC	MBM29F800BA55TN					