

ONKYO SERVICE MANUAL

DVD CHANGER MODEL DV-CP701

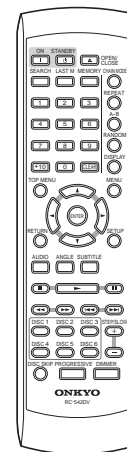
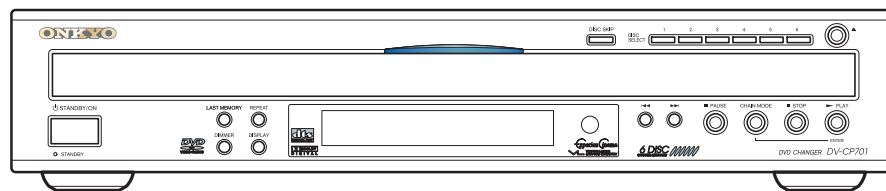

RC-542DV

Black and Silver models

B MDD, S MDD	120V AC, 60Hz
B MPA	220-230V AC, 50/60Hz

SAFETY-RELATED COMPONENT WARNING!!

COMPONENTS IDENTIFIED BY MARK  ON THE SCHEMATIC DIAGRAM AND IN THE PARTS LIST ARE CRITICAL FOR RISK OF FIRE AND ELECTRIC SHOCK. REPLACE THESE COMPONENTS WITH ONKYO PARTS WHOSE PART NUMBERS APPEAR AS SHOWN IN THIS MANUAL.

MAKE LEAKAGE-CURRENT OR RESISTANCE MEASUREMENTS TO DETERMINE THAT EXPOSED PARTS ARE ACCEPTABLY INSULATED FROM THE SUPPLY CIRCUIT BEFORE RETURNING THE APPLIANCE TO THE CUSTOMER.

SPECIFICATIONS

Video system		Standard NTSC (U.S. model), PAL/AUTO (Australian model)
Region code		1 (U.S. model), 4 (Australian model)
Laser		Semiconductor laser, wavelength 650 nm (DVD), 780 nm (CD)
Frequency response	DVD linear audio	4 Hz-22 kHz @ 48 kHz sampling rate 4 Hz-44 kHz @ 96 kHz sampling rate
	CD audio	4 Hz-20 kHz
Signal-to-noise ratio (digital audio)		100 dB
Audio dynamic range (digital audio)		96 dB
Harmonic distortion (digital audio)		0.001%
Wow and flutter		Below measurable level (+/-0.001% (W. PEAK)) or less
Operating conditions	Temperature	5° to 35° C (41° F to 95° F)
	Installation	Install horizontally
Video outputs	COMPONENT VIDEO	Y: 1.0 V (p-p), 75 ohm, negative sync, RCA/phono x 3 Pb/Pr: 0.7 V (p-p), 75 ohm
	S VIDEO (S-Video)	Y: 1.0 V (p-p), 75 ohm, negative sync, 4-pin mini DIN x 1 C: 0.286 V (p-p), 75 ohm
	VIDEO (composite video)	1.0 V (p-p), 75 ohm, negative sync, RCA/phono x 1
Audio outputs	OPTICAL	Optical connector x 1
	COAXIAL	0.5 V (p-p), 75 ohm, RCA/phono x 1
	ANALOG	2.0 V rms, 470 ohm, RCA/phono x 2
General	Power supply	120 V AC, 60 Hz (U.S. model) 220-230 V AC, 50/60 Hz (Australian model)
	Power consumption	13 W
	Power consumption in Standby mode	1.6 W (U.S. model) 2.0 W (Australian model)
	Weight	5.3 kg (11.7 lbs.)
Dimensions (W x H x D)		435 X 91 X 432 mm (17-1/8 X 3-9/16 X 17)

Specifications and features subject to change without notice.

SERVICE PROCEDURES-1

PROTECTION OF EYES FROM LASER BEAM DURING SERVICING

This set employs a laser. Therefore, be sure to follow carefully the instructions below when servicing.

WARNING!!

SERVICE WARNING : DO NOT APPROACH THE LASER EXIT WITH THE EYE TOO CLOSELY. IN CASE IT IS NECESSARY TO CONFIRM LASER BEAM EMISSION, BE SURE TO OBSERVE FROM A DISTANCE OF MORE THAN 30cm FROM THE SURFACE OF THE OBJECTIVE LENS ON THE OPTICAL PICKUP BLOCK.

Laser Diode Properties

Wavelength: 650/780nm (DVD/CD)

WARNING

WARNING:

TO REDUCE THE RISK OF FIRE OR ELECTRIC SHOCK, DO NOT EXPOSE THIS APPLIANCE TO RAIN OR MOISTURE.

CAUTION:

TO REDUCE THE RISK OF ELECTRIC SHOCK, DO NOT REMOVE COVER (OR BACK). NO USER-SERVICEABLE PARTS INSIDE. REFER SERVICING TO QUALIFIED SERVICE PERSONNEL.



WARNING
RISK OF ELECTRIC SHOCK
DO NOT OPEN

AVIS
RISQUE DE CHOC ELECTRIQUE
NE PAS OUVRIR



The lightning flash with arrowhead symbol, within an equilateral triangle, is intended to alert the user to the presence of uninsulated "dangerous voltage" within the product's enclosure that may be of sufficient magnitude to constitute a risk of electric shock to persons.



The exclamation point within an equilateral triangle is intended to alert the user to the presence of important operating and maintenance (servicing) instructions in the literature accompanying the appliance.

LASER WARNING

This unit contains a semiconductor laser system and is classified as a "CLASS 1 LASER PRODUCT". So, to use this model properly, read this Instruction Manual carefully. In case of any trouble, please contact the store where you purchased the unit. To prevent being exposed to the laser beam, do not try to open the enclosure.

CAUTION:

VISIBLE LASER RADIATION WHEN OPEN AND INTERLOCK FAILED OR DEFEATED. DO NOT STARE INTO BEAM.

CAUTION:

THIS PRODUCT UTILIZES A LASER. USE OF CONTROLS OR ADJUSTMENTS OR PERFORMANCE OF PROCEDURES OTHER THAN THOSE SPECIFIED HEREIN MAY RESULT IN HAZARDOUS RADIATION EXPOSURE.

The label on the right is applied on the rear panel except for USA and Canadian models.

"CLASS 1 LASER PRODUCT"

1. This unit is a CLASS 1 LASER PRODUCT and employs a laser inside the cabinet.
2. To prevent the laser from being exposed, do not remove the cover. Refer servicing to qualified personnel.

SERVICE PROCEDURE

1. Replacing the fuses

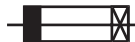

This symbol located near the fuse indicates that the fuse used is show operating type, For continued protection against fire hazard, replace with same type fuse , For fuse rating, refer to the marking adjust to the symbol.

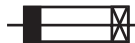

Ce symbole indique que le fusible utilise est e lent. Pour une protection permanente, n'utiliser que des fusibles de meme type. Ce demier est indique la qu le present symbol est appose.

REF. NO.	PART NO.	DESCRIPTION
F001	252185 or	1.6A-UL/T-237
	252252	1.6A-T/UL-ST2 <MDD> North American area
F001	252075 or 252275	2.5A-SE-EAK 2.5A-SE-TL250V <MPA> Australian area

LASER BEAM CAUTION LABEL



WAVE LENGTH:650nm
MAX LASER POWER:0.5mW
波 長 : 650nm
最大レーザー出力 : 0.5mW

98764160



SERVICE PROCEDURES-2

2. Safety-check out

(Only U.S.A. model)

After correcting the original service problem perform the following safety check before releasing the set to the customer

Connect the insulating-resistance tester between the plug of power supply cord and terminal GND on the back panel.

Specifications: More than 10M ohm at 500V

INITIALIZING

Factory-shipped condition

Push button "ON" (Mechanical SW)

Press the [STOP] and [STANDBY] same time with NO DISC condition.

Push button "STANDBY".

After display "COMPLETE".

REMOVE THE SOLDER OF LASER DIODE SHORT

When replace the mechanism or DVD main PC board.

Shotting the solder of Shot-circuit land. (2 positions)

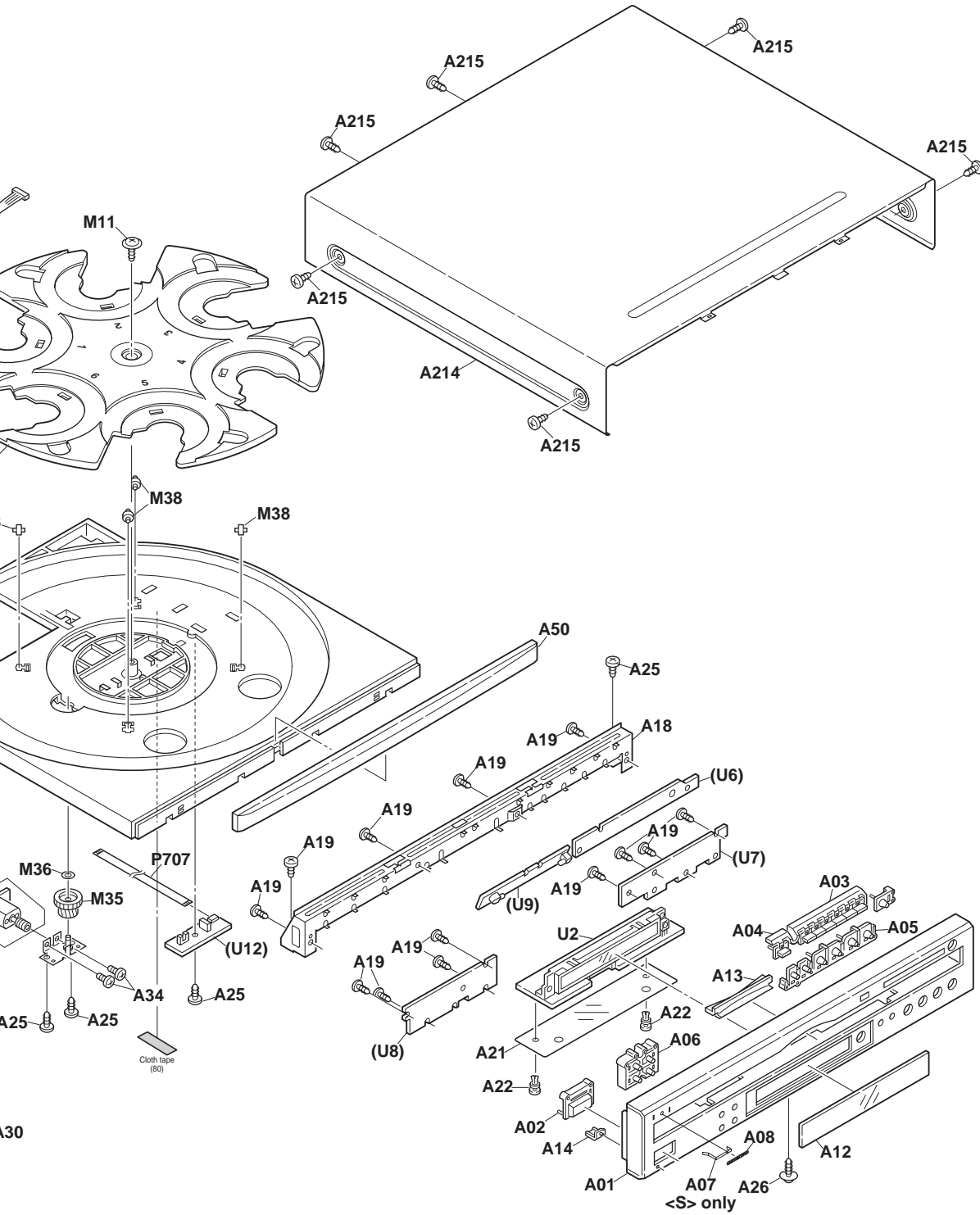

A

B

C

D

EXPLODED VIEW

1

2

3

4

5

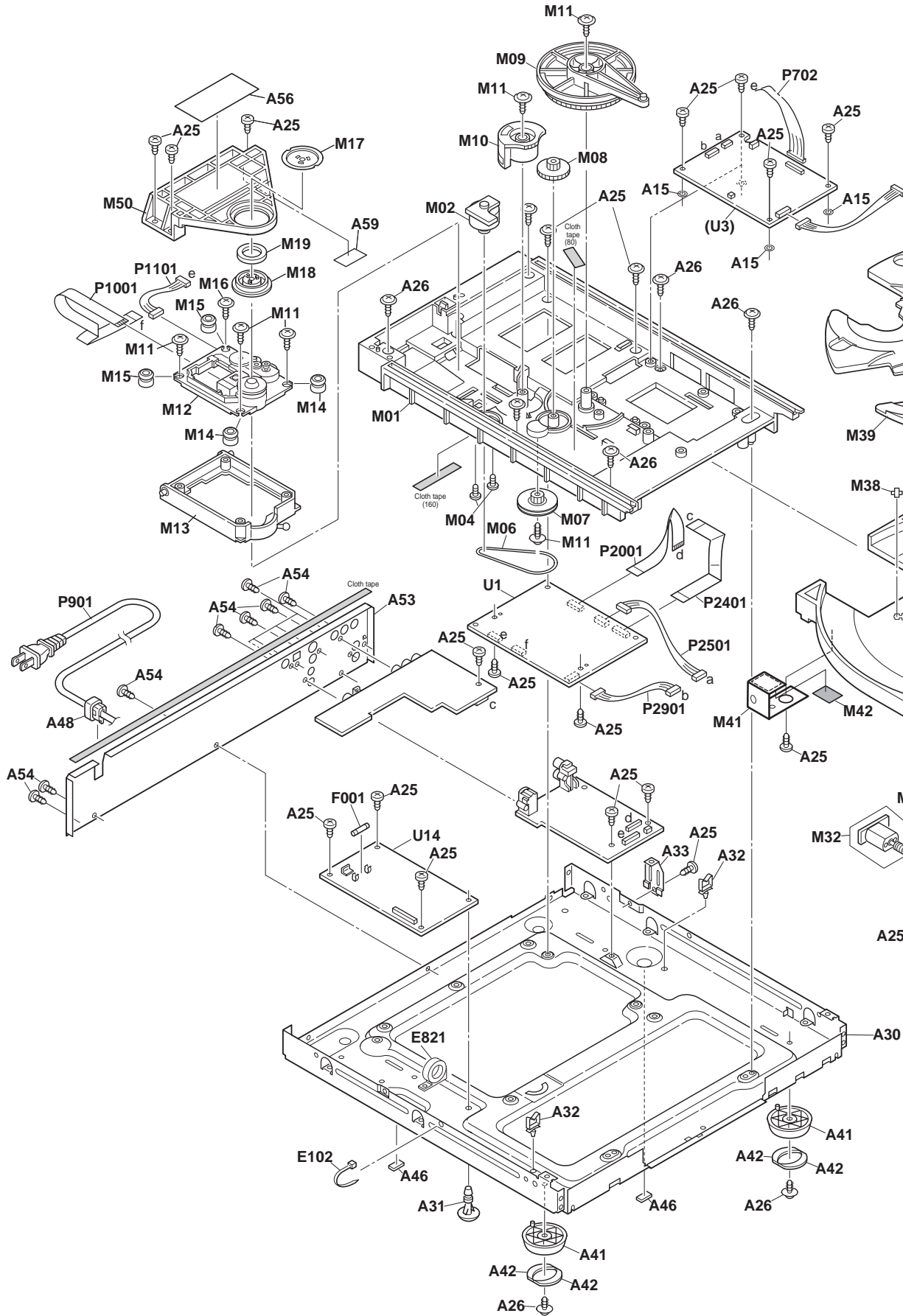

A B C D E F G H

EXPLODED VIEW

1

2

3

4

5

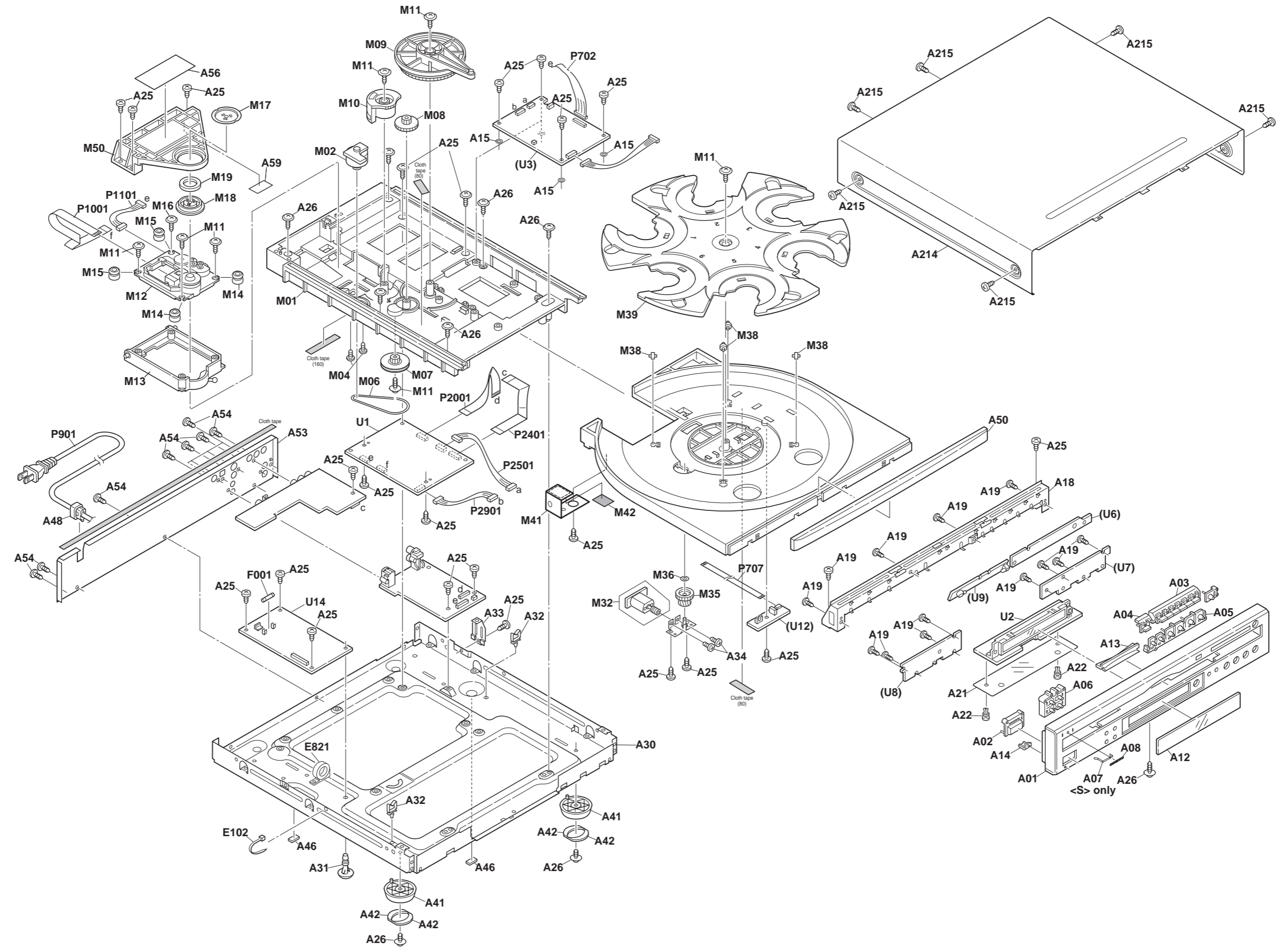

BLOCK DIAGRAM

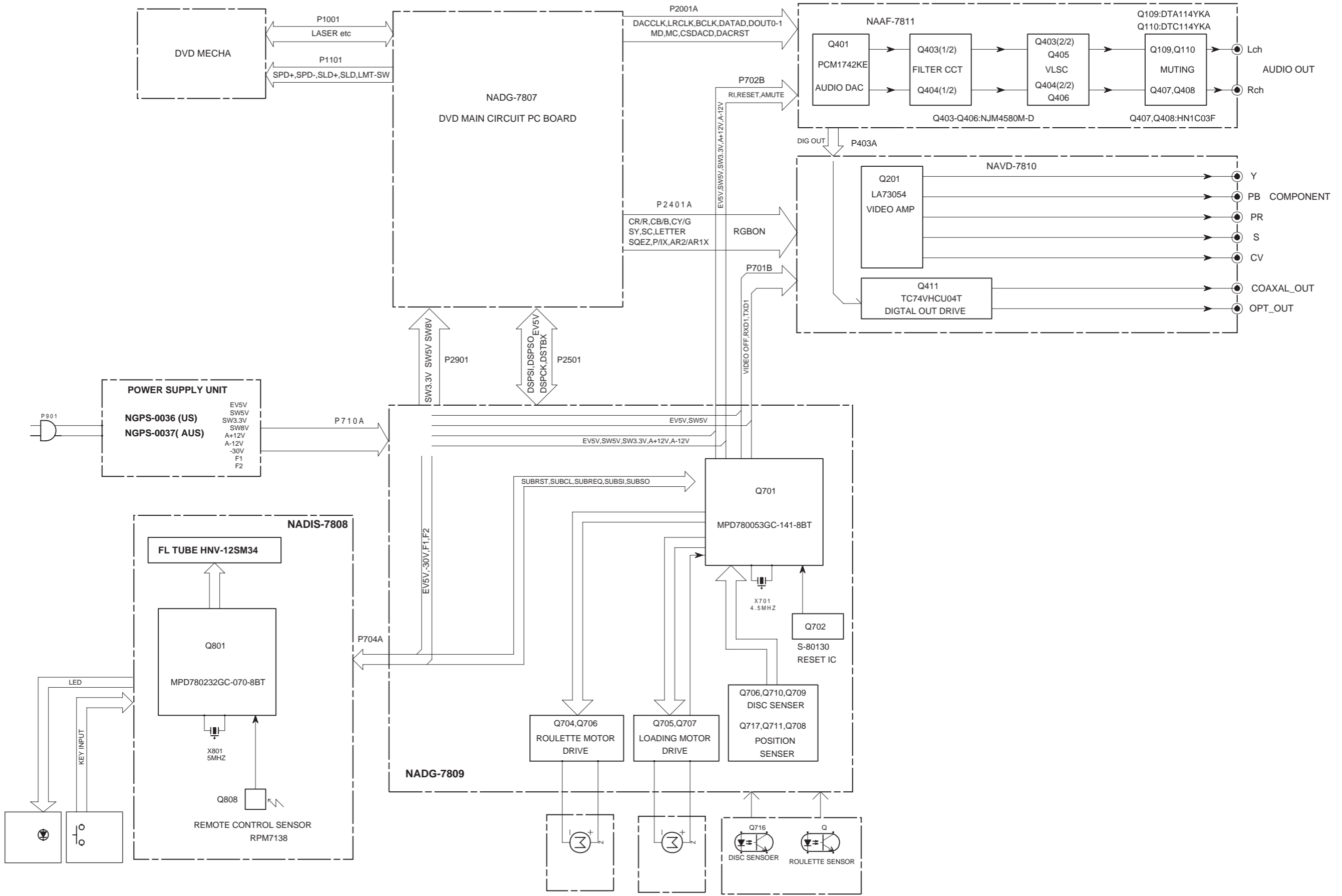

BLOCK DIAGRAM

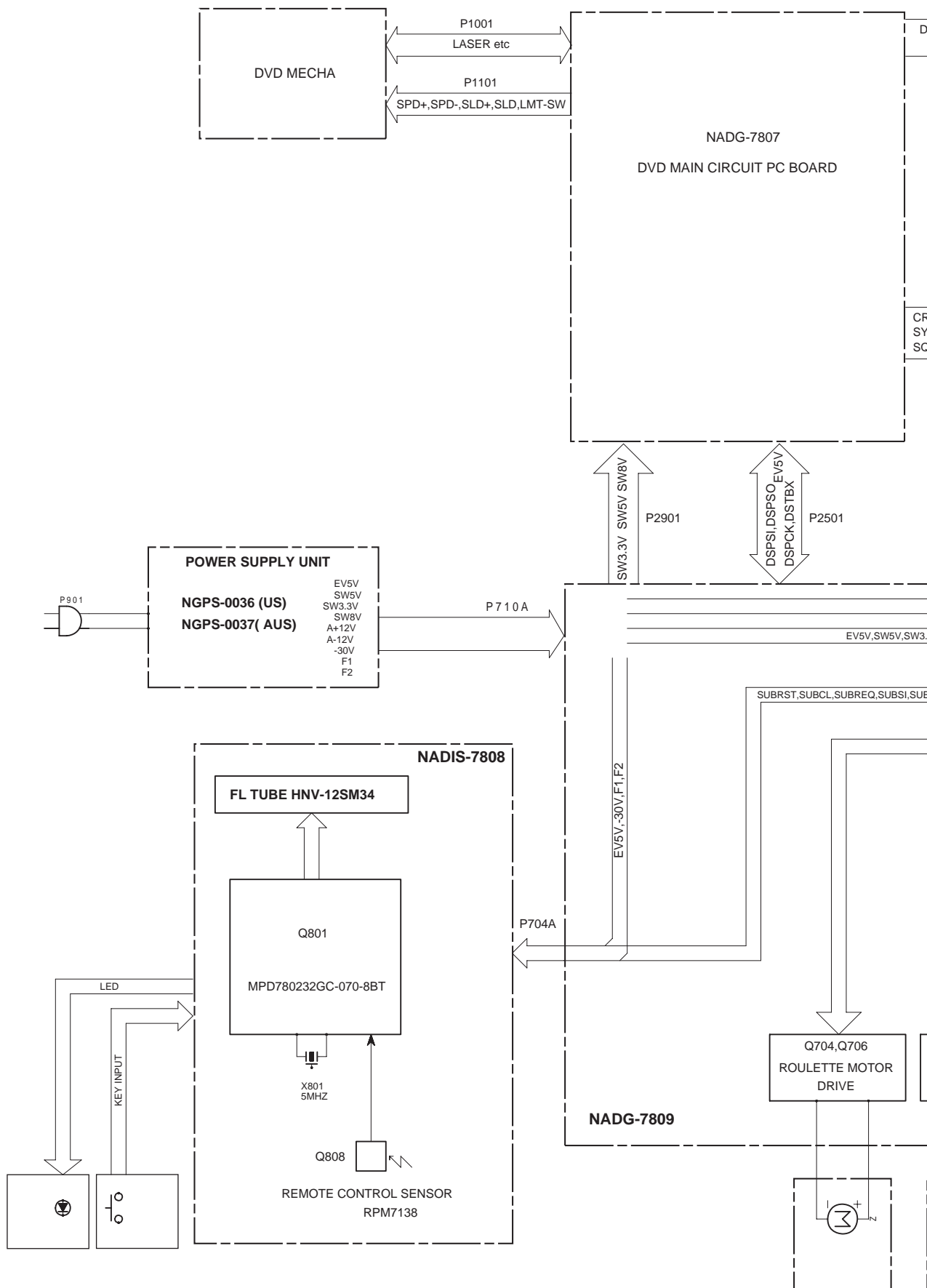

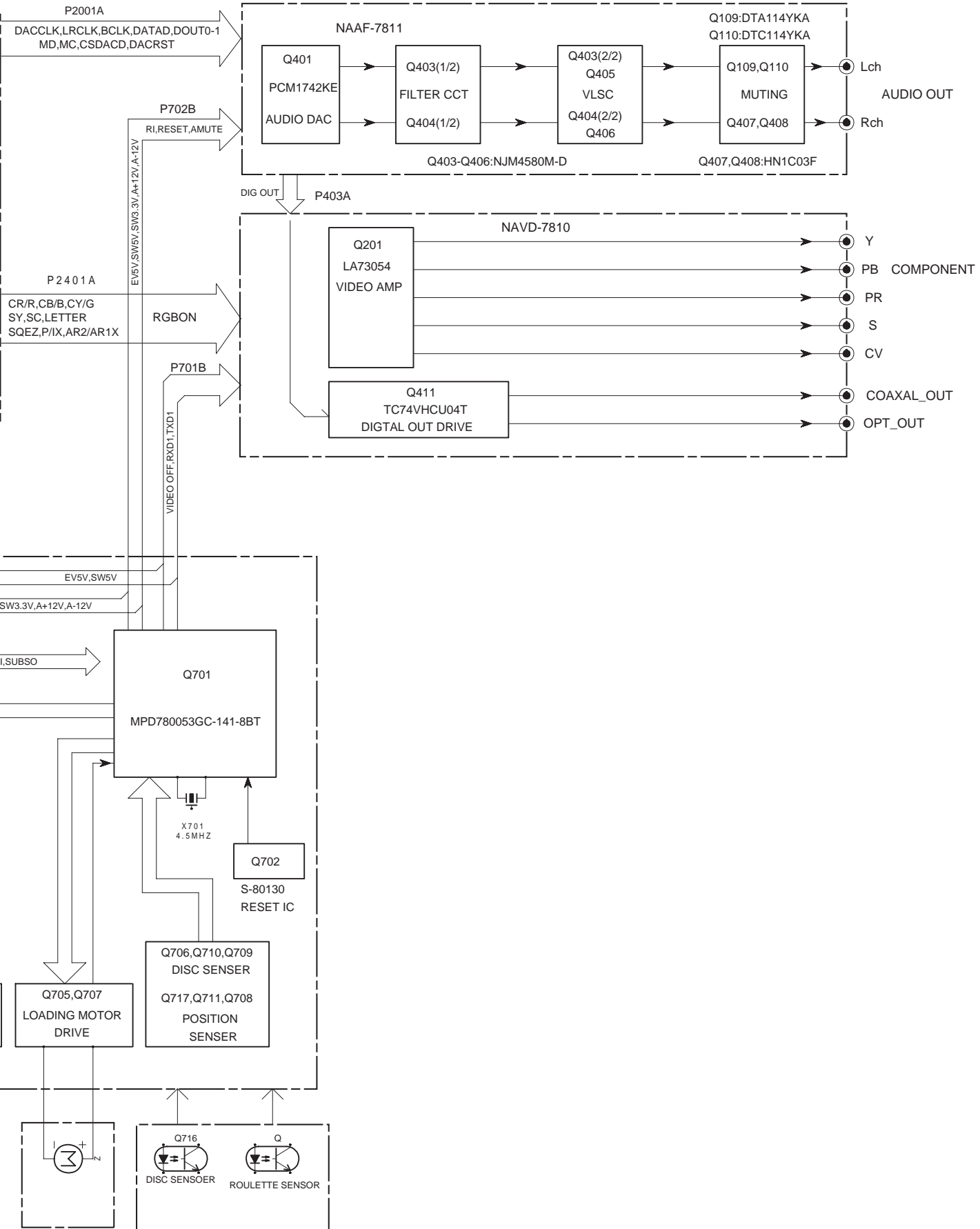

E F G H

IN CIRCUIT PC BOARD-1 (F/E SECTION) NADG-7807

NADG-7807

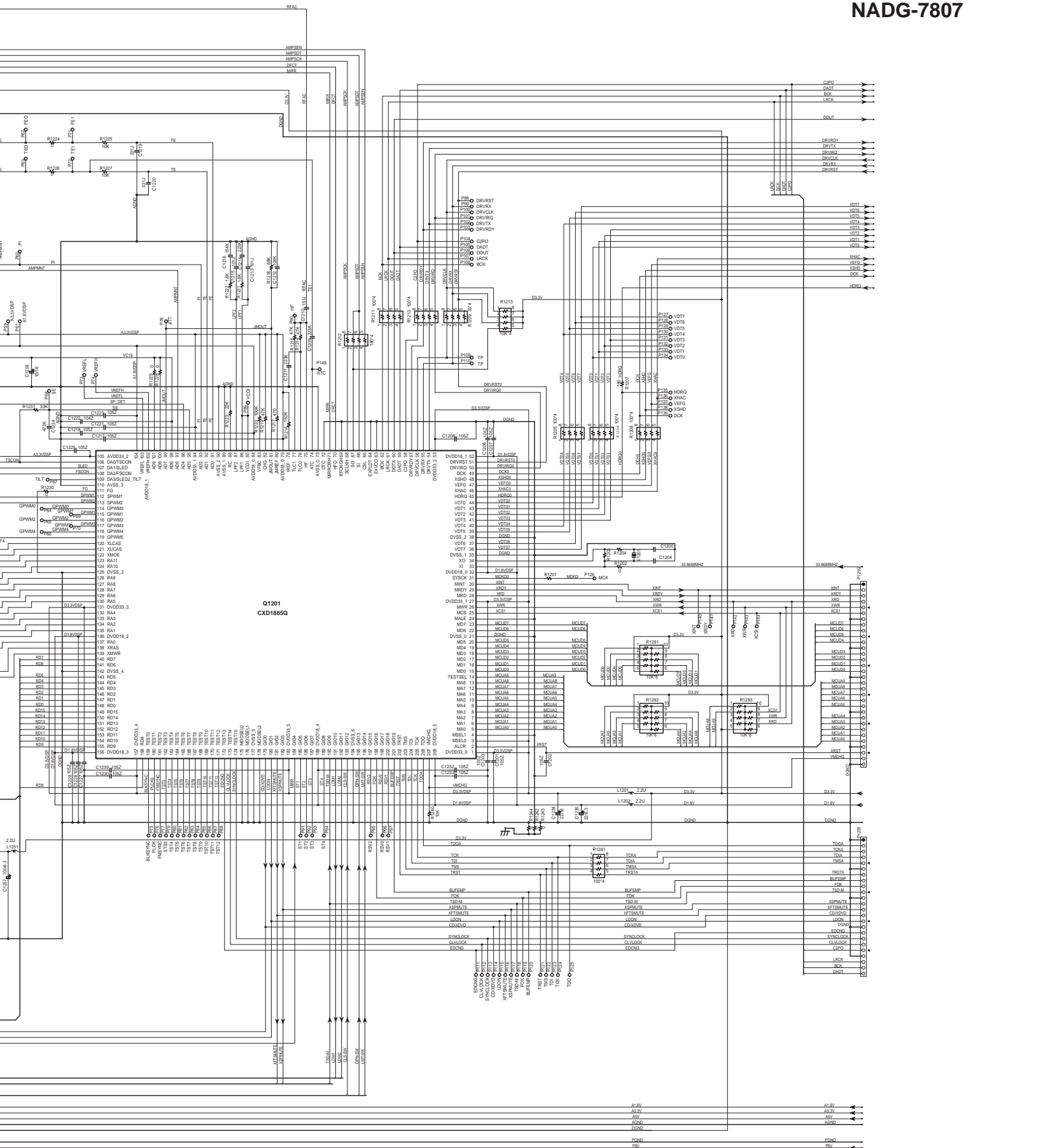

SCHEMATIC DIAGRAM

A

B

C

D

U1 : DVD MAIN

1

2

3

4

5

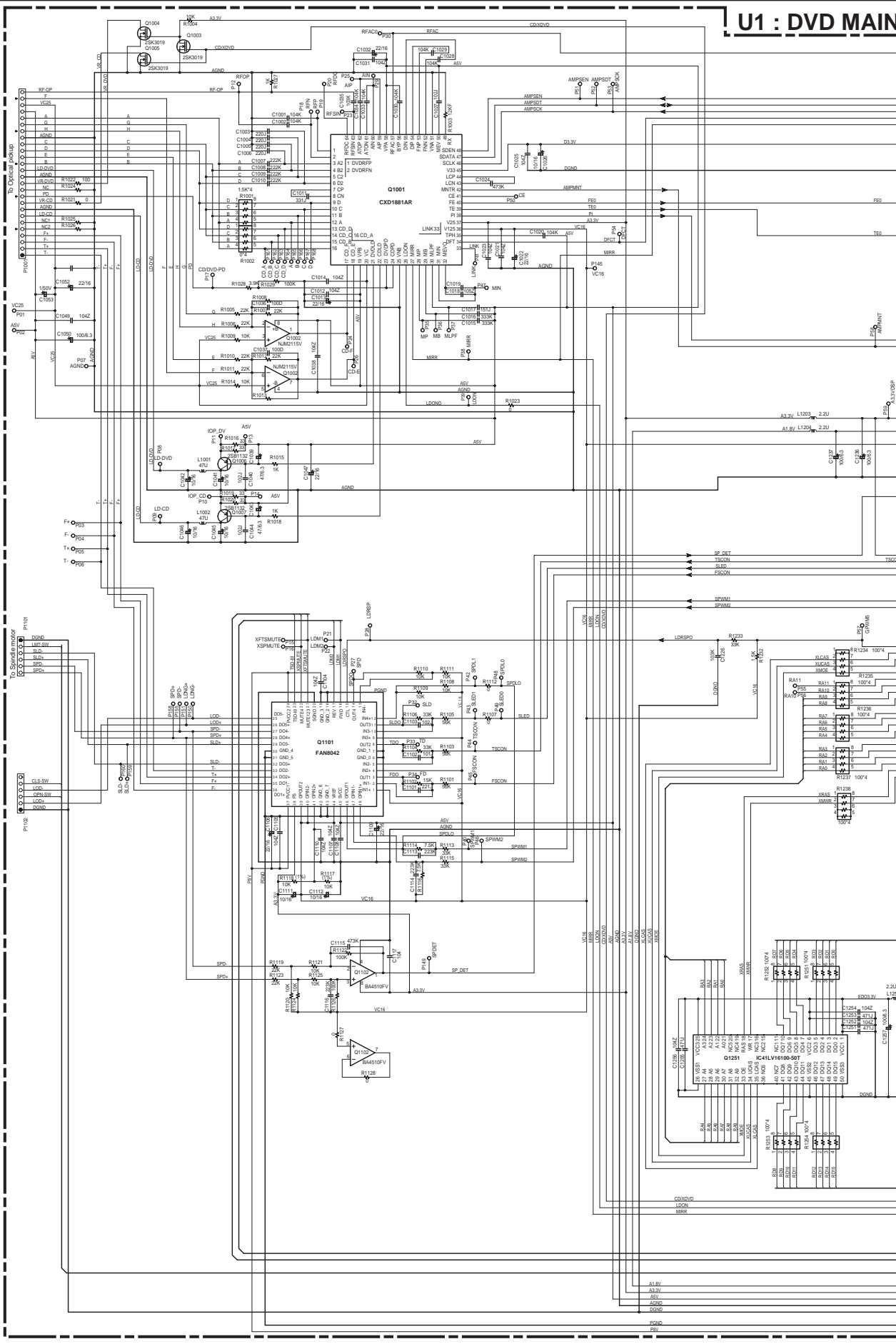

SCHEMATIC DIAGRAM

U1 : DVD MAIN CIRCUIT PC BOARD-1 (F/E SECTION) NADG-7807

NADG-7807

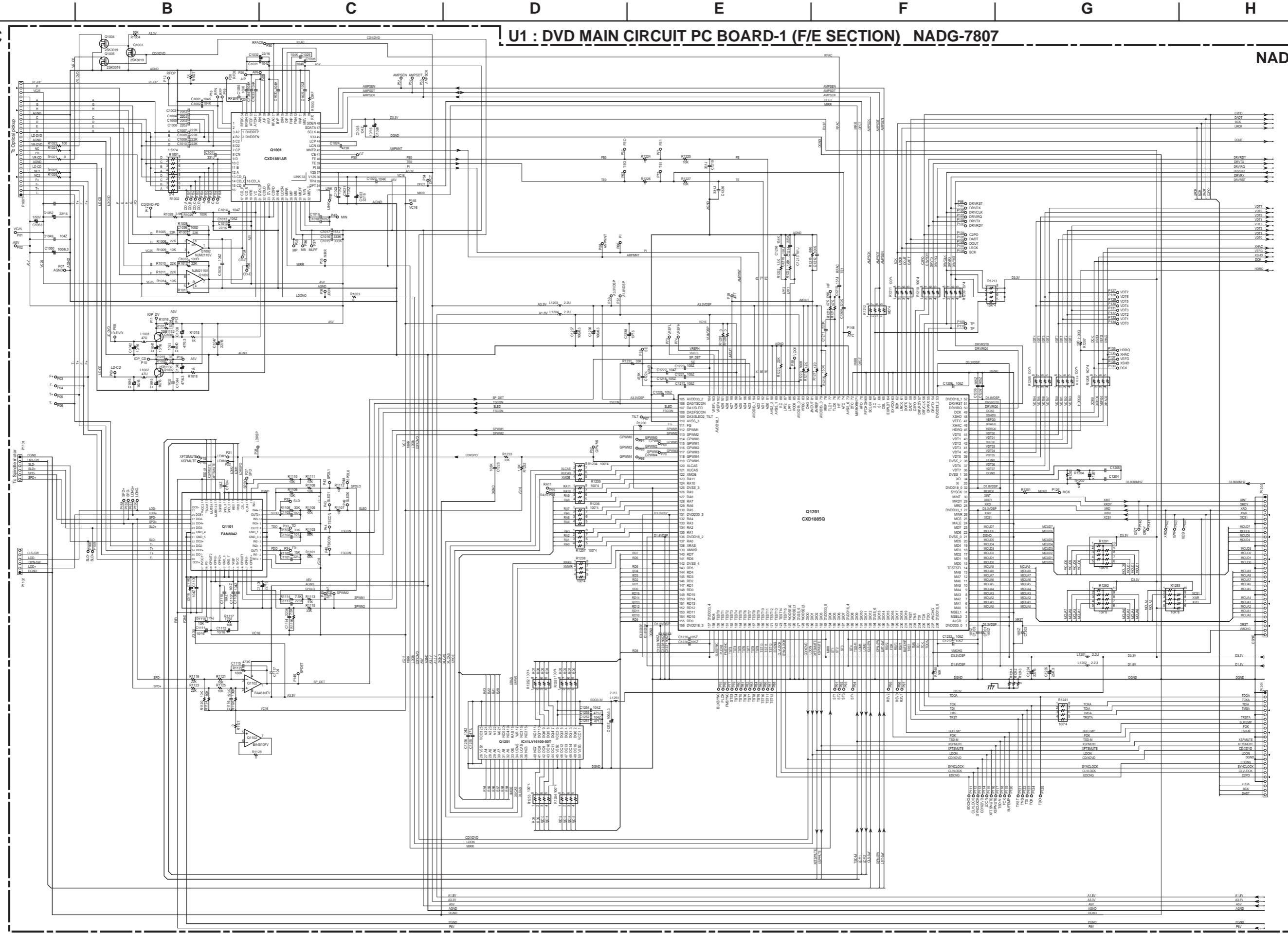

1

2

3

4

5

A

B

C

D

E

F

G

H

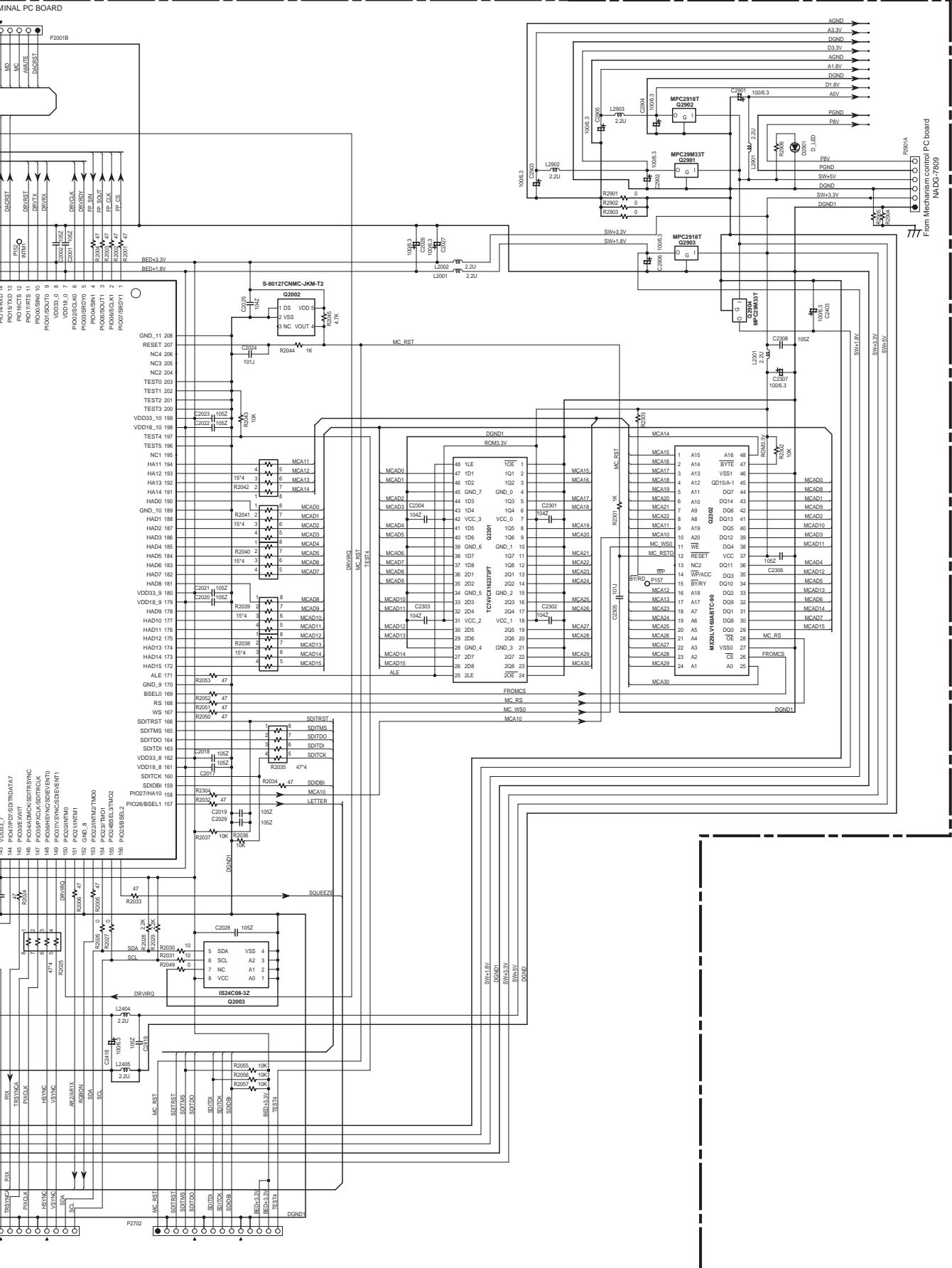

SCHEMATIC DIAGRAM

U1 : DVD MAIN CIRCUIT PC BOARD-2 (B/E SECTION) NADG-7807

To AUDIO OUTPUT TERMINAL NAAF-7811

1

2

3

4

5

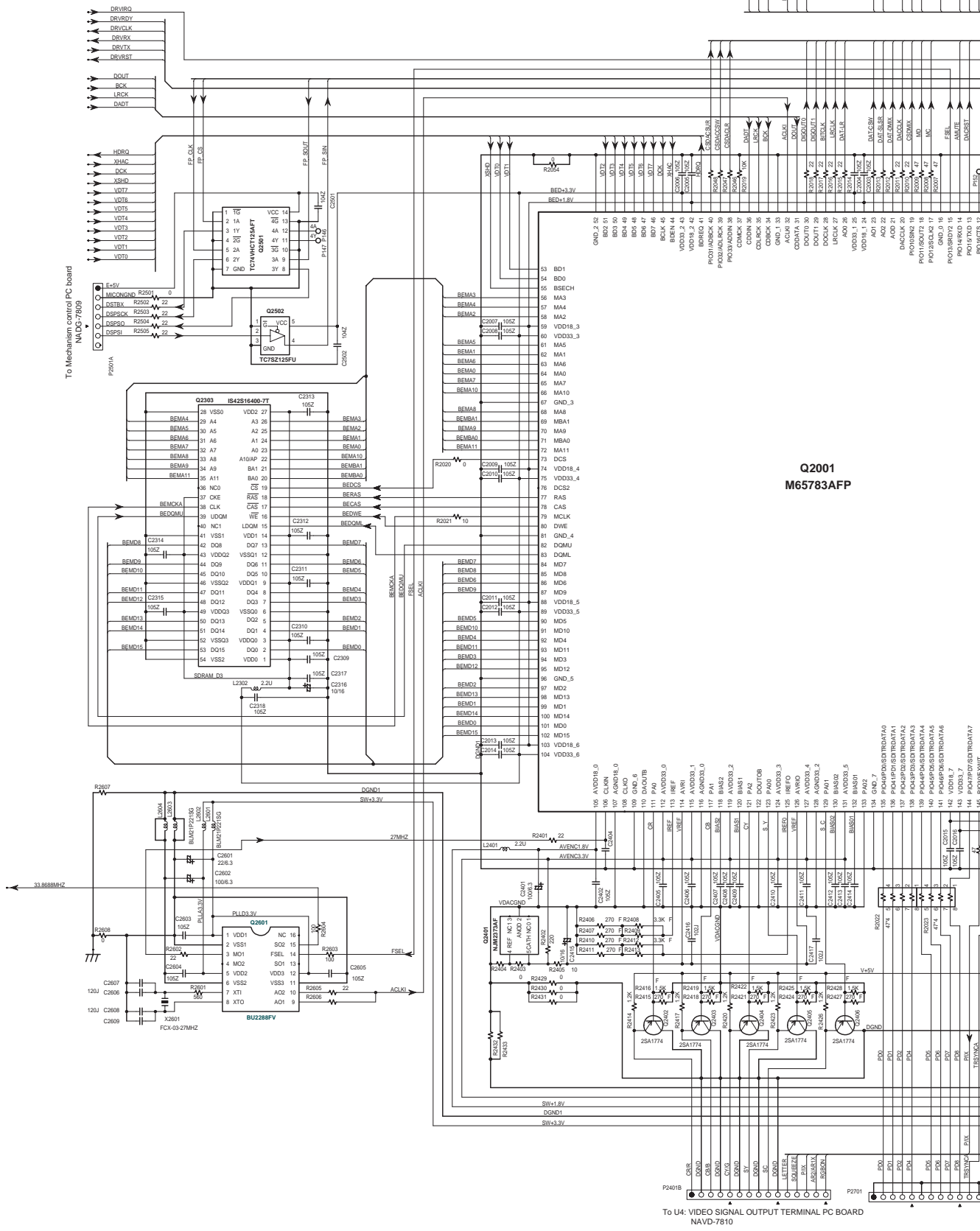

To U4: VIDEO SIGNAL OUTPUT TERMINAL PC BOARD NAVD-7810

SCHEMATIC
DIAGRAM

U1 : DVD MAIN CIRCUIT PC BOARD-2 (B/E SECTION) NADG-7807

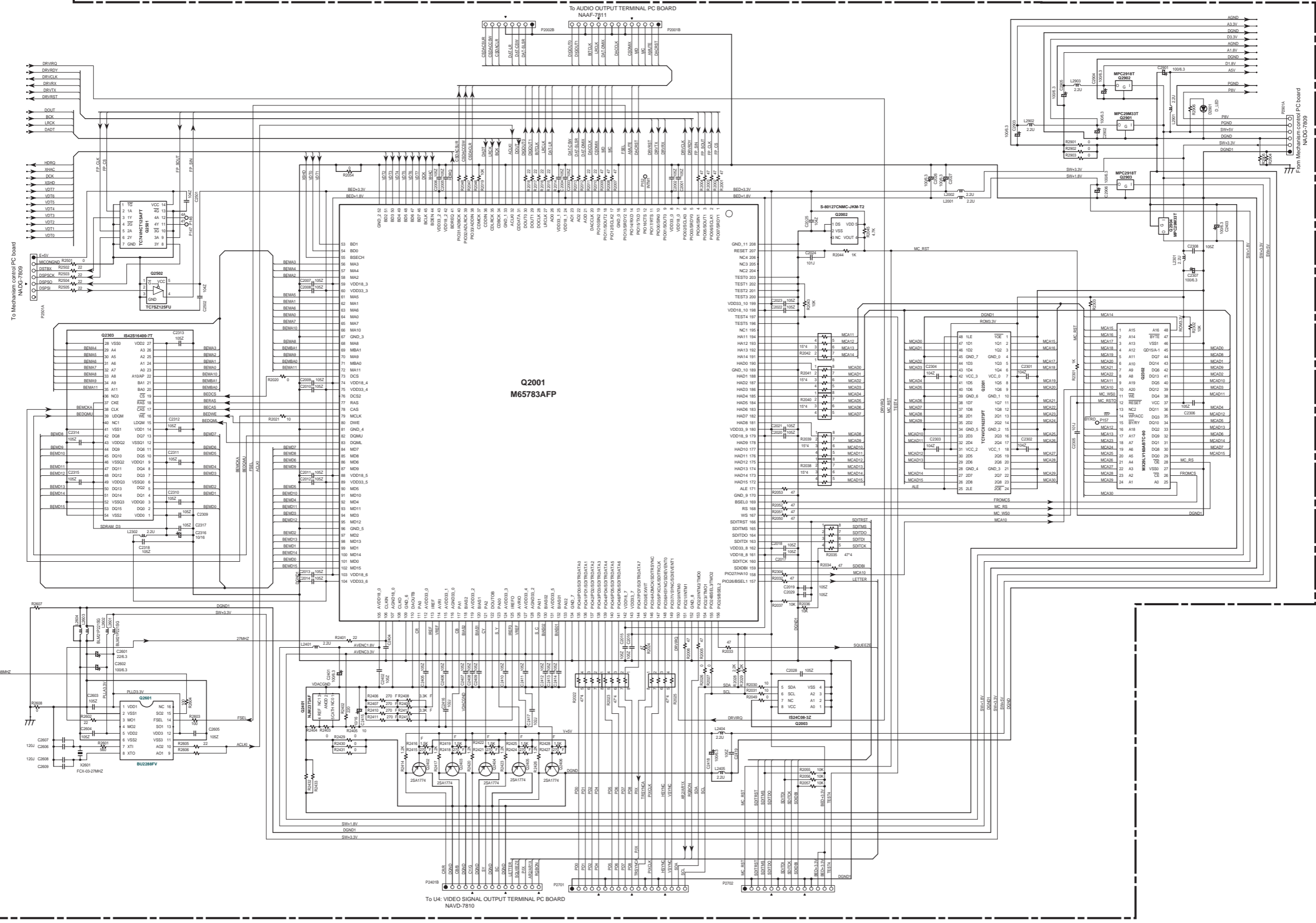

To U4 : VIDEO SIGNAL OUTPUT TERMINAL PC BOARD NADV-7810

To AUDIO OUTPUT TERMINAL PC BOARD NAAF-7811

From Mechanism control PC board NADG-7809

1

2

3

4

5

U3 : MECHANISM CONTROL CIRCUIT PC BOARD NADG-7809

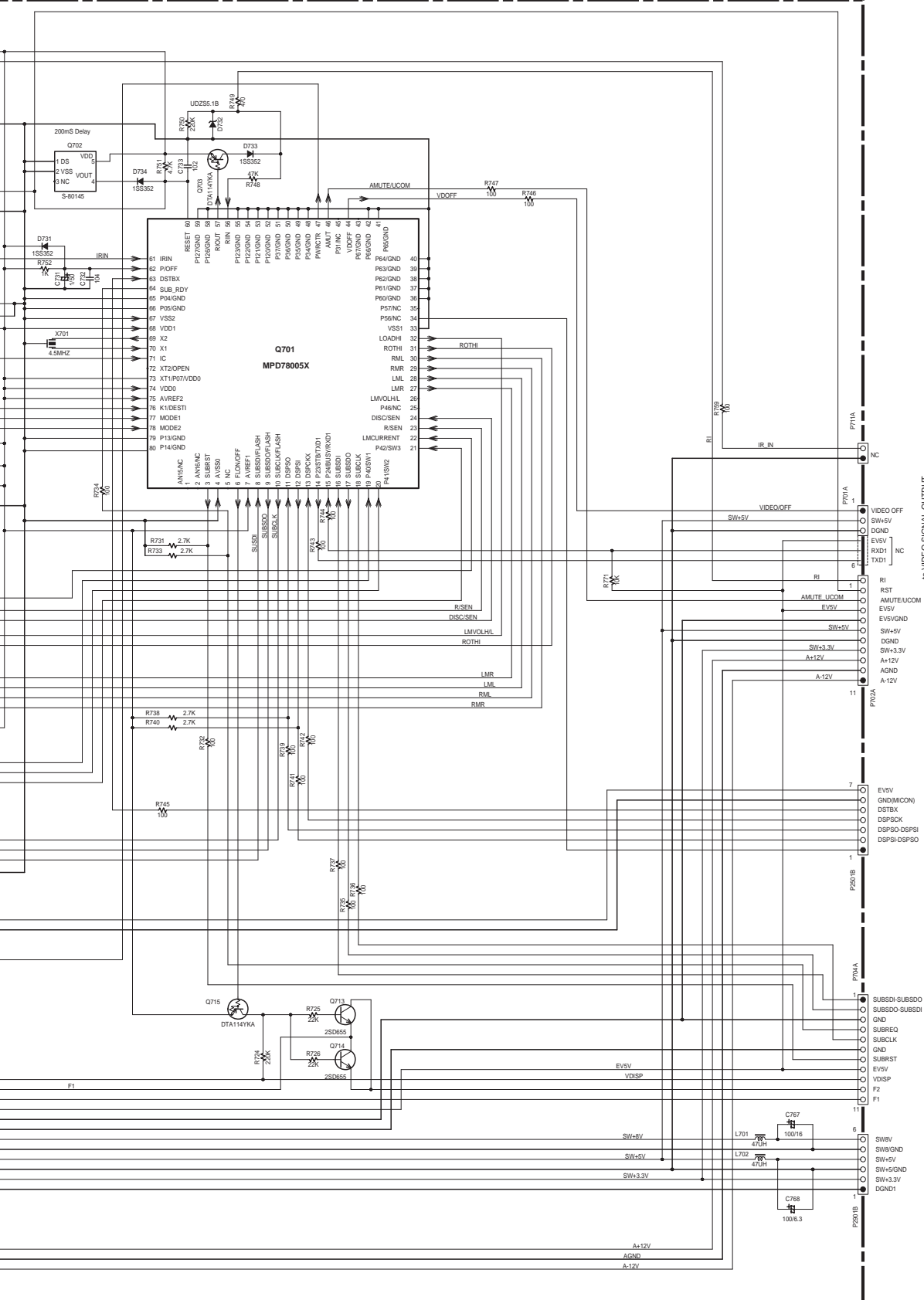

to VIDEO SIGNAL OUTPUT
TERMINAL PC BOARD

to AUDIO SIGNAL OUT PUT
TERMINAL PC BOARD

to DVD MAIN CIRCUIT PC BOARD

to DISPLAY CIRCUIT PC BOARD

A

B

C

D

SCHEMATIC DIAGRAM

U12 : DISC SENSOR PC BOARD NAETC-7818

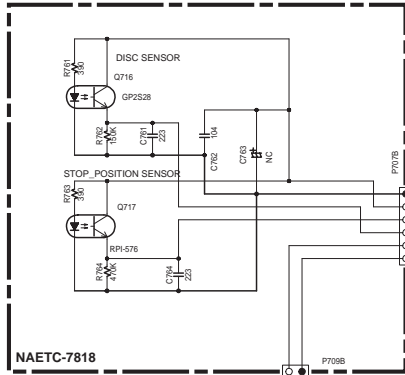

U10 : ROULETTE MOTOR PC BOARD NAETC-7816

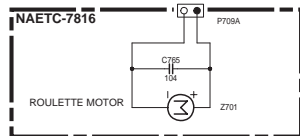

U11 : LOADING MOTOR PC BOARD NAETC-7817

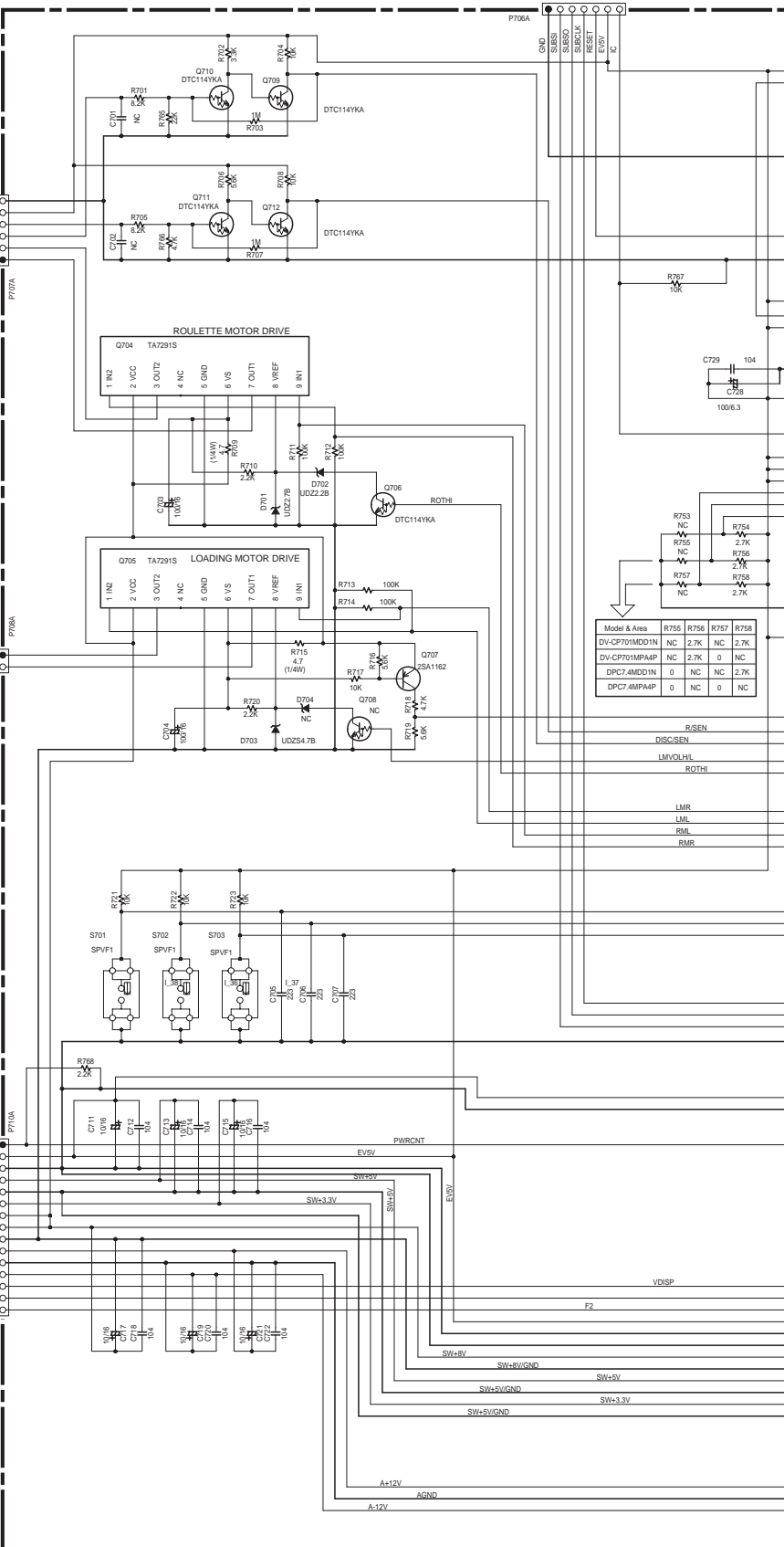
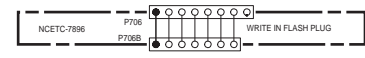
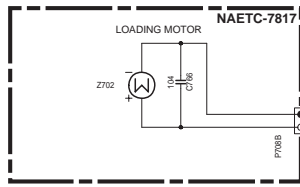

Model & Area	R755	R756	R757	R758
DI-CPT01MDD1N	NC	2.7K	NC	2.7K
DI-CPT01MPP4P	NC	2.7K	0	NC
DPC7 AMDD1N	0	NC	NC	2.7K
DPC7 AMP4P	0	NC	0	NC

R5EN
DISCSEN
LMV0LHL
ROTH#
LMR
LML
RML
RMR

from POWER SUPPLY UNIT

P-ON 1
EV5V
EV+5V/GND
SW+5V
SW+5V/GND
SW+3.3V
SW+8V
SW+8V
SW+8V/GND
A+12V
AGND
A-12V
VDISP-30V
F1
F2 15

1

2

3

4

5

A

B

C

D

PRINTED CIRCUIT BOARD VIEW FROM COMPONENT SIDE VIEW

(U3) : MECHANISM CONTROL PC BOARD (NADG-7809)

1

2

3

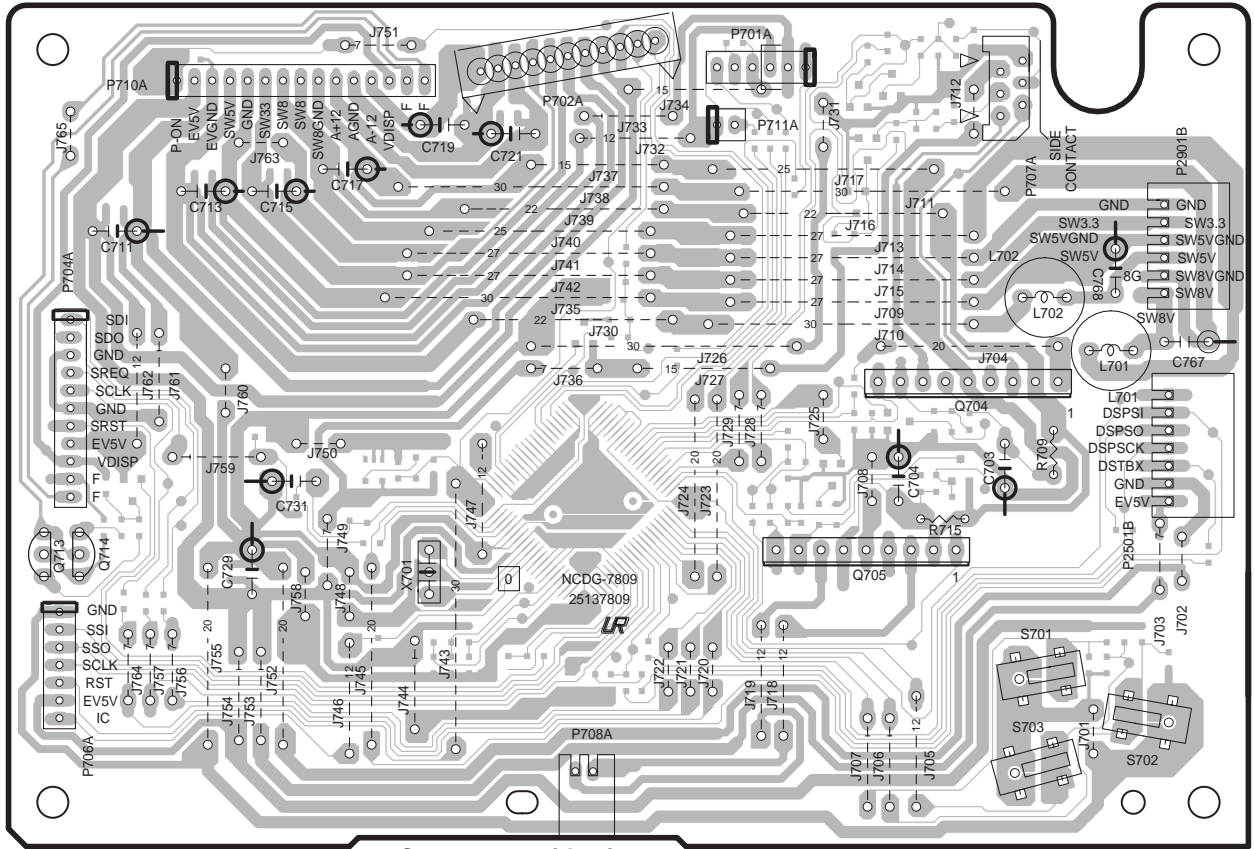

Component side view

4

5

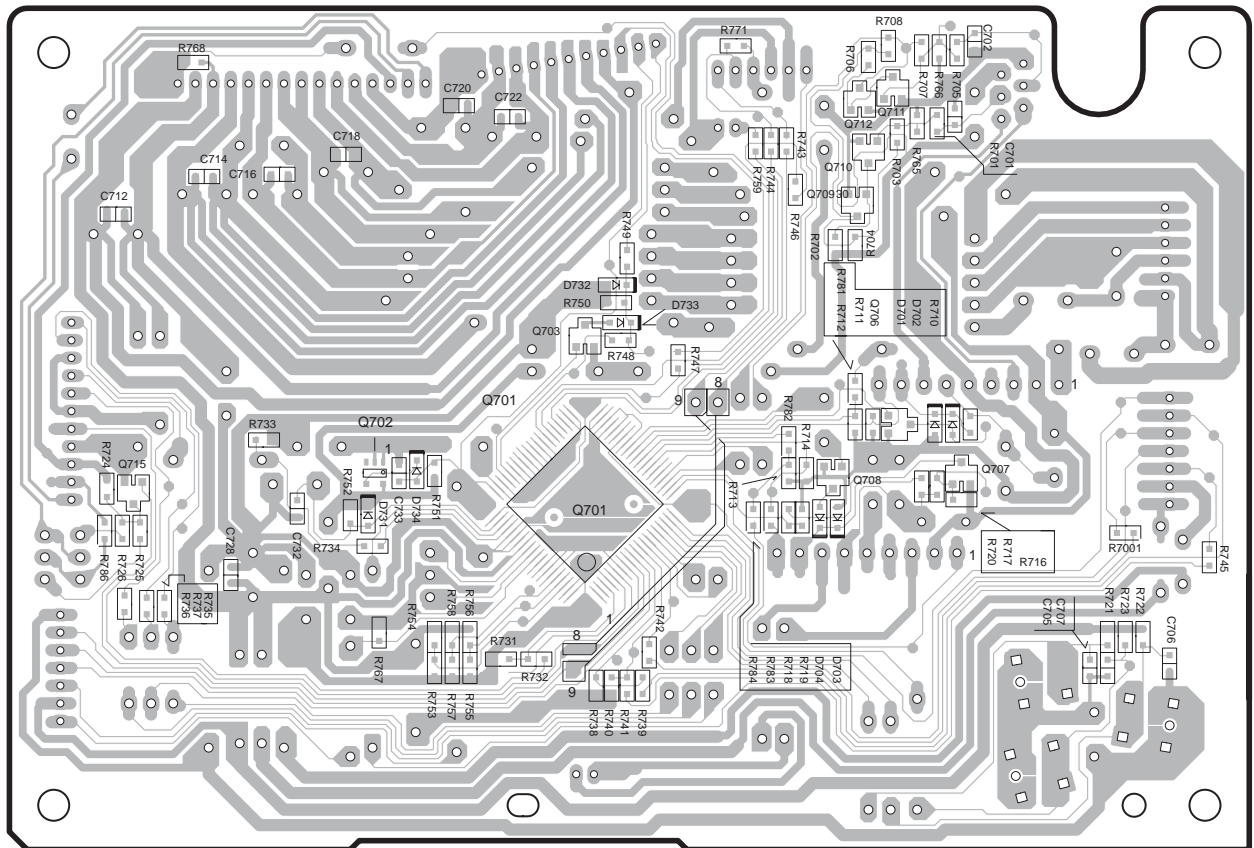

Soldering side view

SCHEMATIC DIAGRAM

U2 : DISPLAY CIRCUIT PC BOARD NADIS-7808

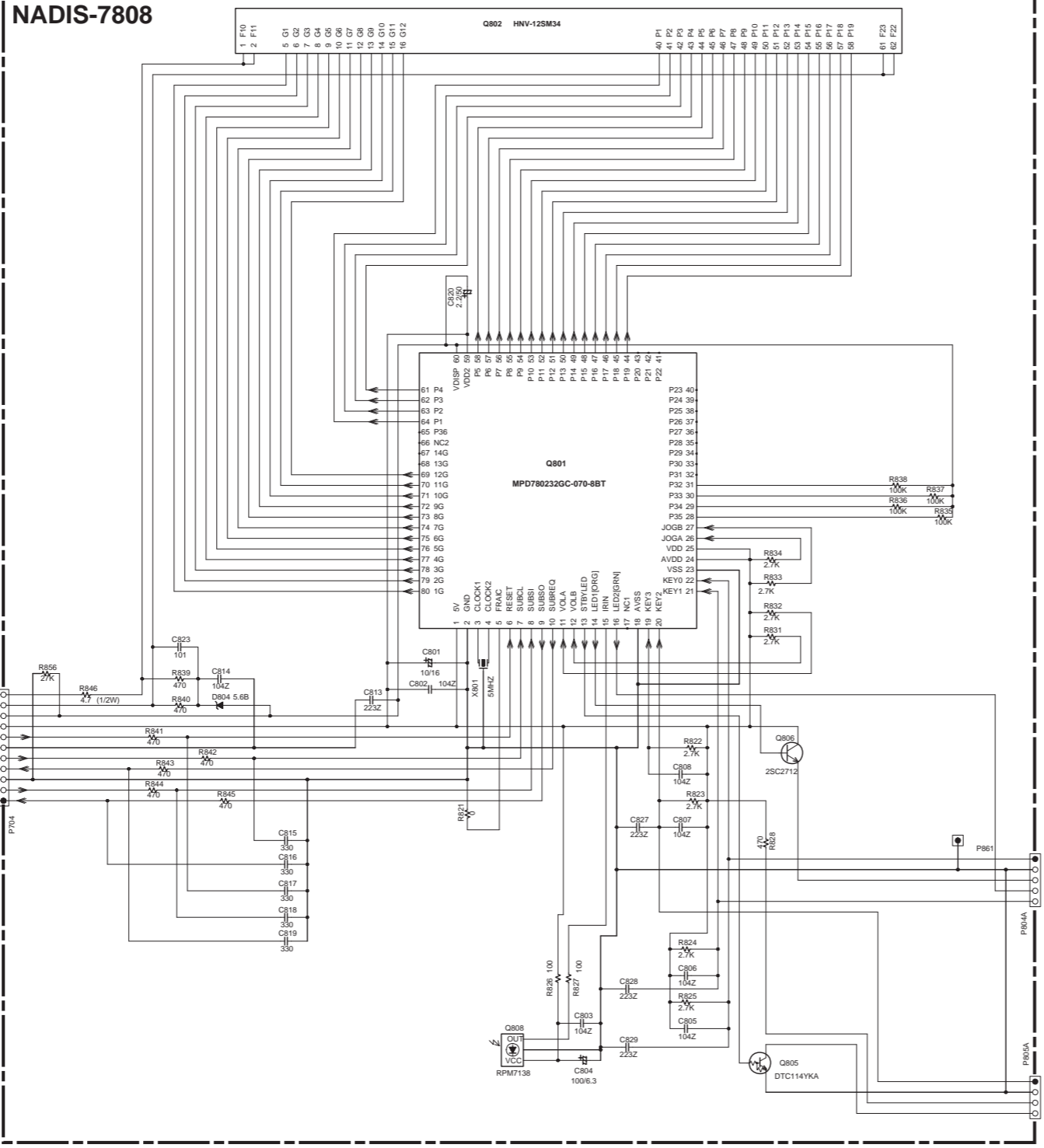

CAUTION
FOR CONTINUED PROTECTION AGAINST FIRE HAZARD, REPLACE ONLY WITH FUSE OF SAME TYPE AND RATING INDICATED.

ATTENTION
AFIN D'ASSURER UNE PROTECTION PERMANENTE CONTRE LES RISQUES D'INCENDIE, REMPLACER UNIQUEMENT PAR UN FUSIBLE DE MEME TYPE ET CALIBRATION COMME INDIQUE.

THIS SYMBOL LOCATED NEAR THE FUSE INDICATES THAT THE FUSE USED IS SLOW OPERATING TYPE FOR CONTINUED PROTECTION AGAINST FIRE HAZARD. REPLACE WITH SAME TYPE FUSE. FOR FUSE RATING REFER TO THE MARKING ADJACENT TO THE SYMBOL.

CE SYMBOLE INDIQUE QUE LE FUSIBLE UTILISE EST S LENT POUR UNE PROTECTION PERMANENTE. UTILISER QUE DES FUSIBLES DE MEME TYPE. CE DARNIER EST INDIQUE LA QU LE PRESENT SYMBOL EST APPOSE.

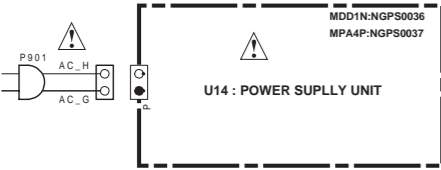

NOTE

- THE COMPONENTS IDENTIFIED BY MARK [triangle with exclamation mark] ARE CRITICAL FOR SAFETY. REPLACE ONLY WITH PART NUMBER SPECIFIED.
- VOLTAGE (MEASURED WITH VOLTMETER) [square with exclamation mark] IS DC VOLTAGE. (NO INPUT SIGNAL)
- ELECTROLYTIC CAPACITORS [polarized capacitor symbol] ARE IN uF/WV.
- ALL CAPACITORS ARE IN pF/50VW UNLESS OTHERWISE NOTED.
- EX) 030 → 3pF 330 → 33pF 331 → 330pF 333 → 0.033uF
- ALL RESISTORS ARE IN OHMS 1/4WATTS UNLESS OTHERWISE NOTED.
- THE THICK LINES ON PC BOARD ARE THE PRINTING SIDE OF THE PARTS.
- EX) [square with circle] — PRINTING SIDE
- CIRCUIT IS SUBJECT TO CHANGE FOR IMPROVEMENT.

U6 : DISC SELECT SWITCH PC BOARD NASW-7812

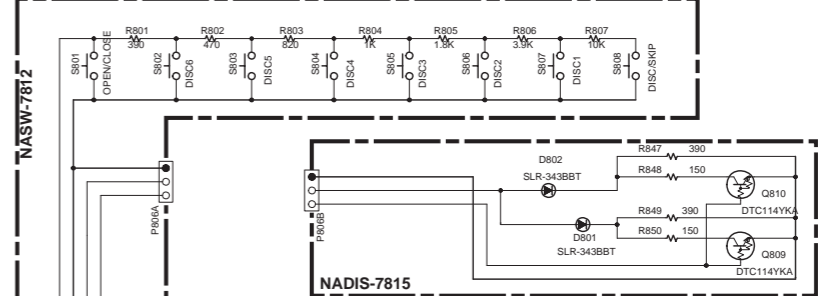

U9 : LED DISPLAY PC BOARD NADIS-7815



U7 : KEY OPERATION SWITCH PC BOARD NASW-7813

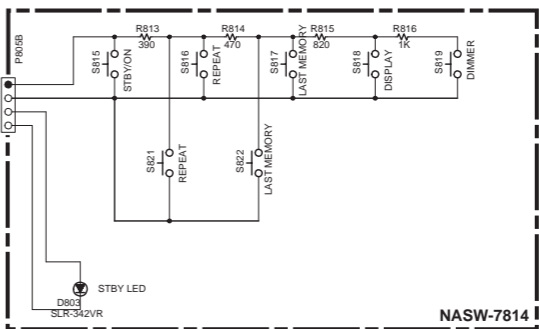
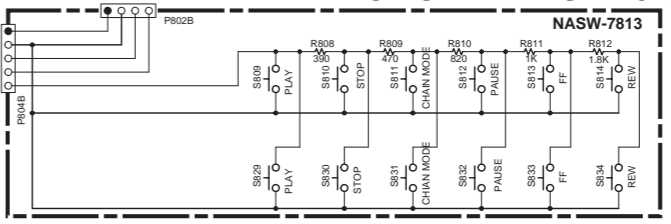

U8 : STANDBY SWITCH PC BOARD NASW-7814

SCHEMATIC DIAGRAM

U2 : DISPLAY CIRCUIT PC BOARD NADIS-7808

NADIS-7808

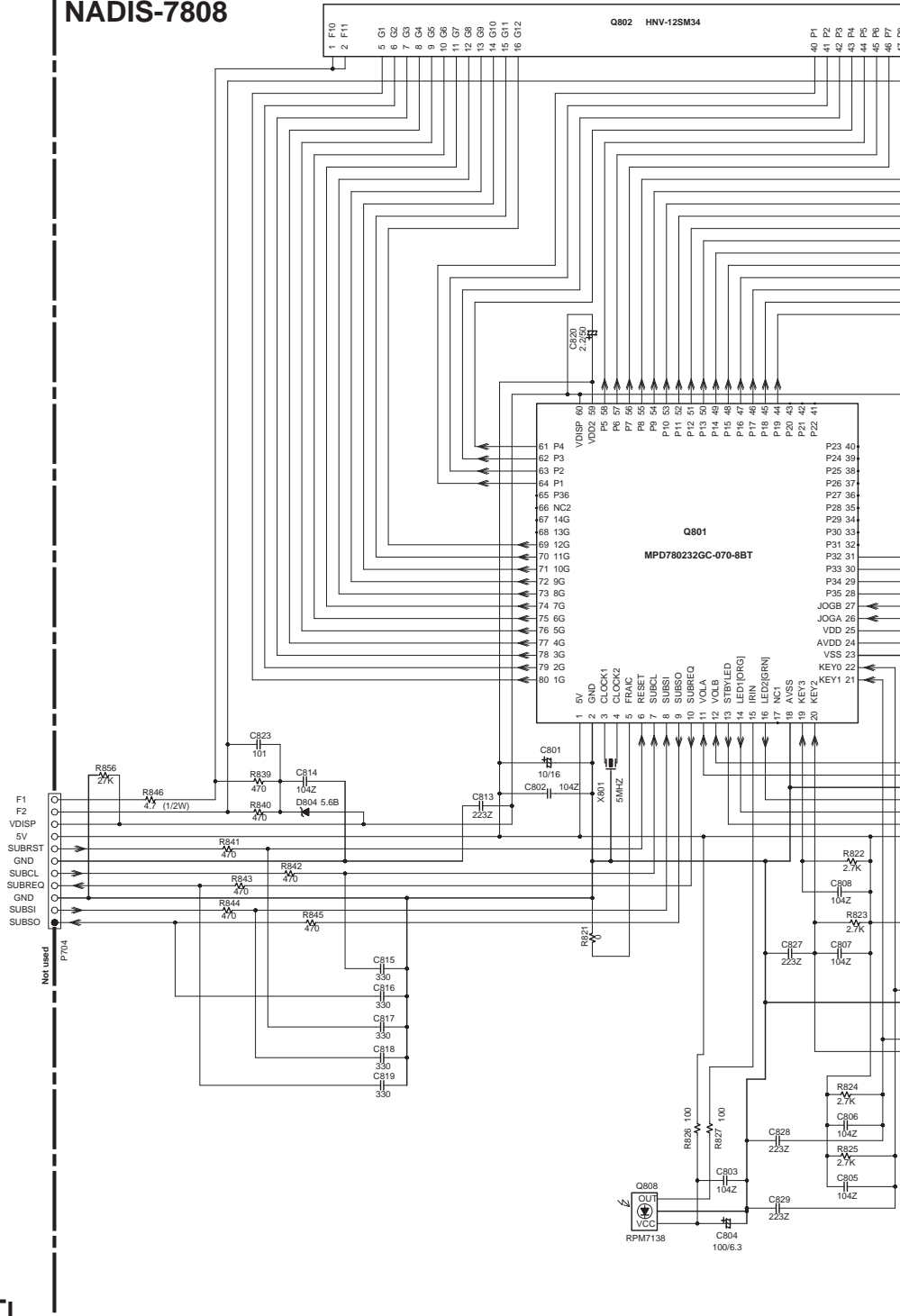

CAUTION
 FOR CONTINUED PROTECTION AGAINST FIRE HAZARD, REPLACE ONLY WITH FUSE OF SAME TYPE AND RATING INDICATED.

ATTENTION
 AFIN D'ASSURER UNE PROTECTION PERMANENTE CONTRE LES RISQUES D'INCENDIE, REMPLACER UNIQUEMENT PAR UN FUSIBLE DE MEME TYPE ET CALIBRATION COMME INDIQUE.

THIS SYMBOL LOCATED NEAR THE FUSE INDICATES THAT THE FUSE USED IS SLOW OPERATING TYPE FOR CONTINUED PROTECTION AGAINST FIRE HAZARD. REPLACE WITH SAME TYPE FUSE. FOR FUSE RATING REFER TO THE MARKING ADJACENT TO THE SYMBOL.

CE SYMBOLE INDIQUE QUE LE FUSIBLE UTILISE EST LENT POUR UNE PROTECTION PERMANENTE. N'UTILISER QUE DES FUSIBLES DE MEME TYPE. CE DERNIER EST INDIQUE LA OU LE PRESENT SYMBOLE EST APPOSE.

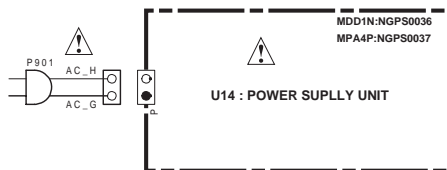

- NOTE**
- THE COMPONENTS IDENTIFIED BY MARK ARE CRITICAL FOR SAFETY. REPLACE ONLY WITH PART NUMBER SPECIFIED.
 - VOLTAGE (MEASURED WITH VOLTMETER) IS DC VOLTAGE. (NO INPUT SIGNAL)
 - ELECTROLYTIC CAPACITORS () ARE IN uF/WV.
 - ALL CAPACITORS ARE IN pF/50WV UNLESS OTHERWISE NOTED.
 EX) 030 -> 3pF 330 -> 33pF 331 -> 330pF 333 -> 0.03uF
 - ALL RESISTORS ARE IN OHMS 1/4WATTS UNLESS OTHERWISE NOTED.
 - THE THICK LINES ON PC BOARD ARE THE PRINTING SIDE OF THE PARTS.
 EX) PRINTING SIDE
 - CIRCUIT IS SUBJECT TO CHANGE FOR IMPROVEMENT.

E

F

G

H

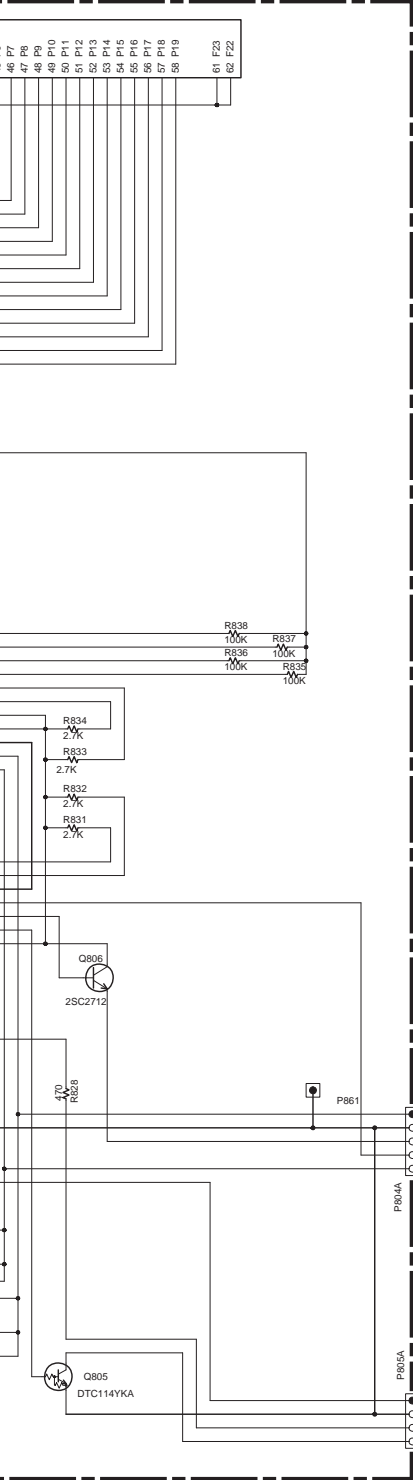

U6 : DISC SELECT SWITCH PC BOARD NASW-7812

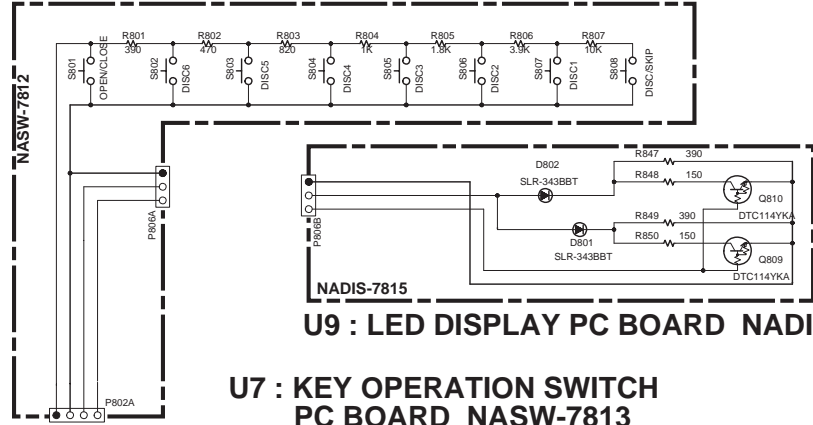

U9 : LED DISPLAY PC BOARD NADIS-7815

U7 : KEY OPERATION SWITCH PC BOARD NASW-7813

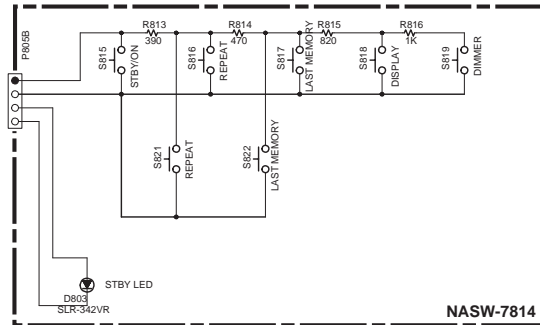
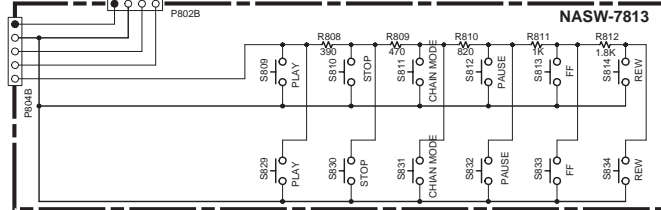

U8: STANDBY SWITCH PC BOARD NASW-7814

SCHEMATIC DIAGRAM U4 : VIDEO SIGNAL OUTPUT TERMINAL PC BOARD (NAVD-7810)

1
2
3
4
5

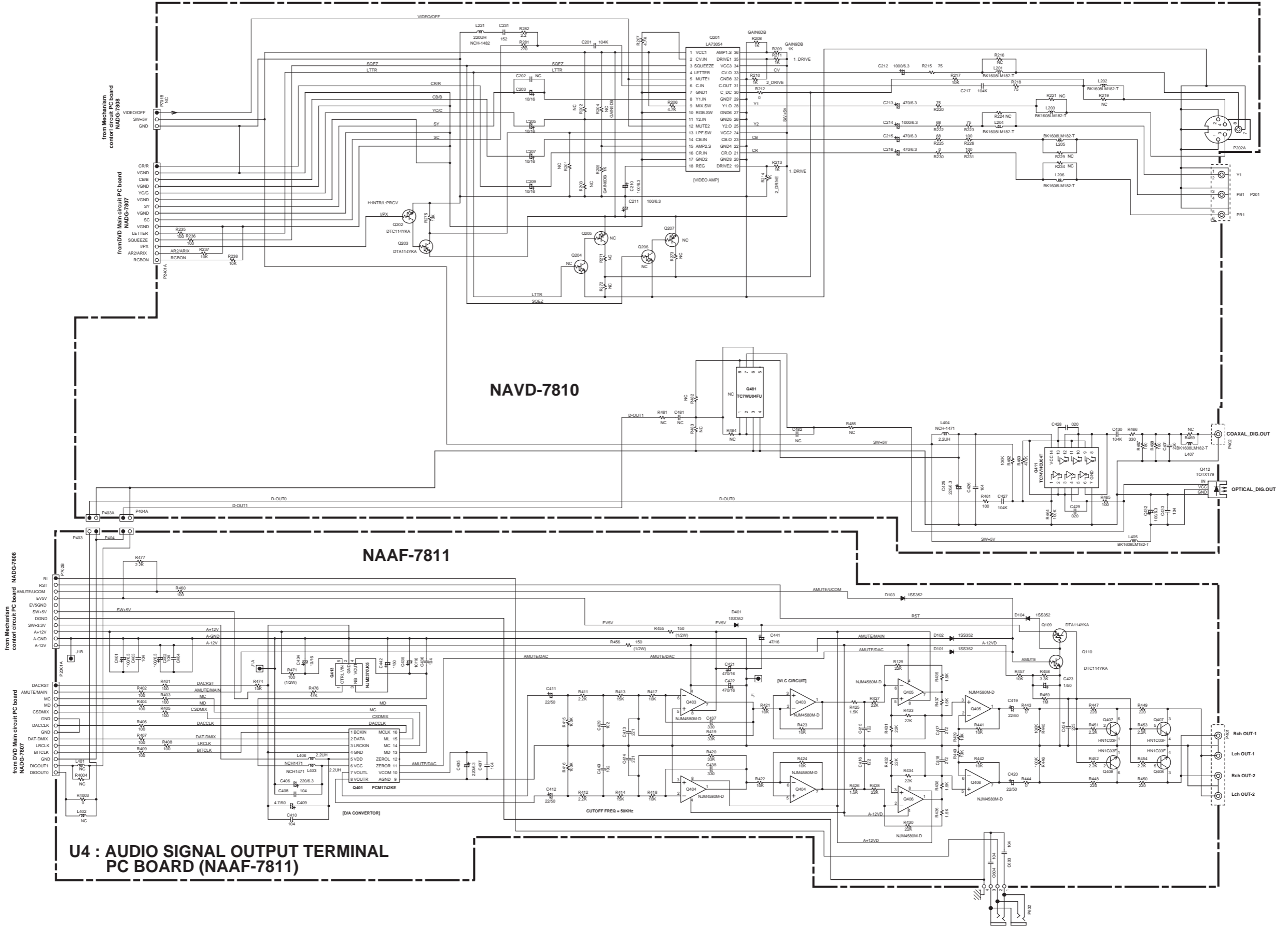

U4 : AUDIO SIGNAL OUTPUT TERMINAL PC BOARD (NAAF-7811)

A

B

C

D

SCHEMATIC DIAGRAM U4 : VIDEO SIGNAL OUTPUT TERMINAL PC BOARD (NAVD-7810)

1

2

3

4

5

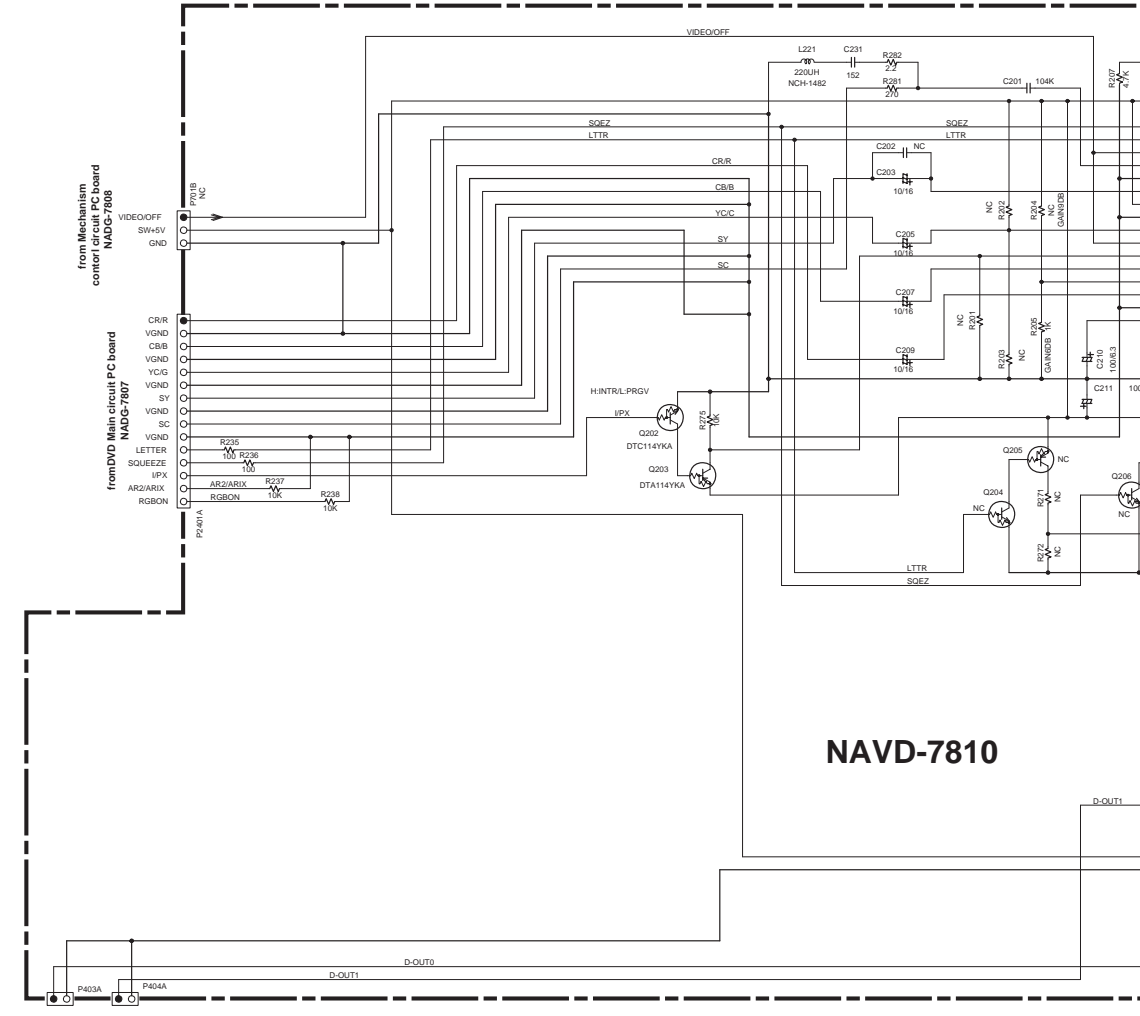

NAVD-7810

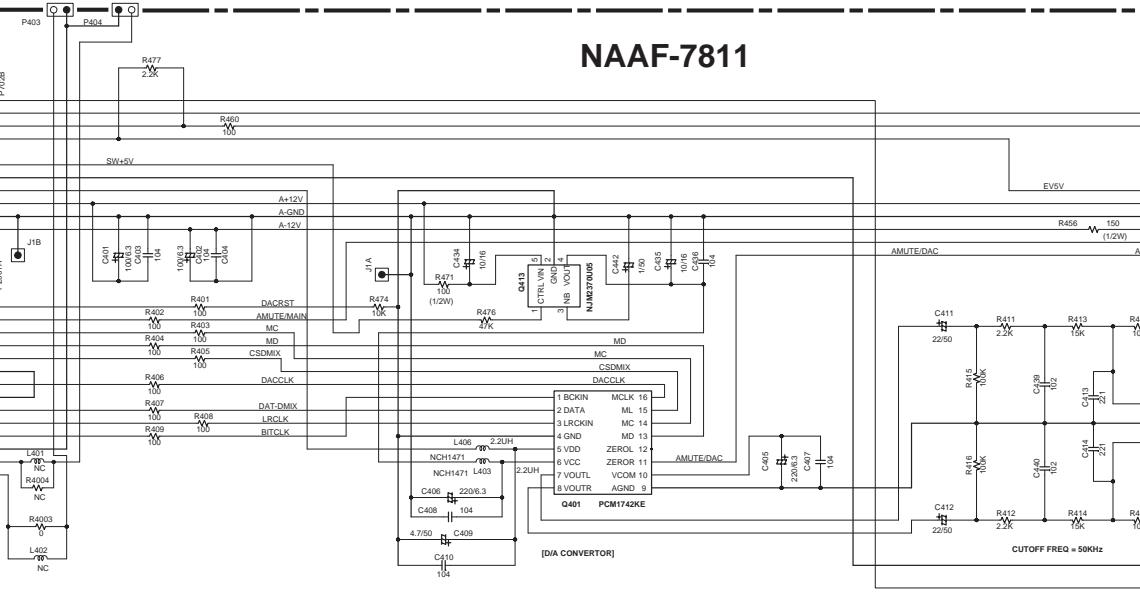

NAAF-7811

U4 : AUDIO SIGNAL OUTPUT TERMINAL PC BOARD (NAAF-7811)

E

F

G

H

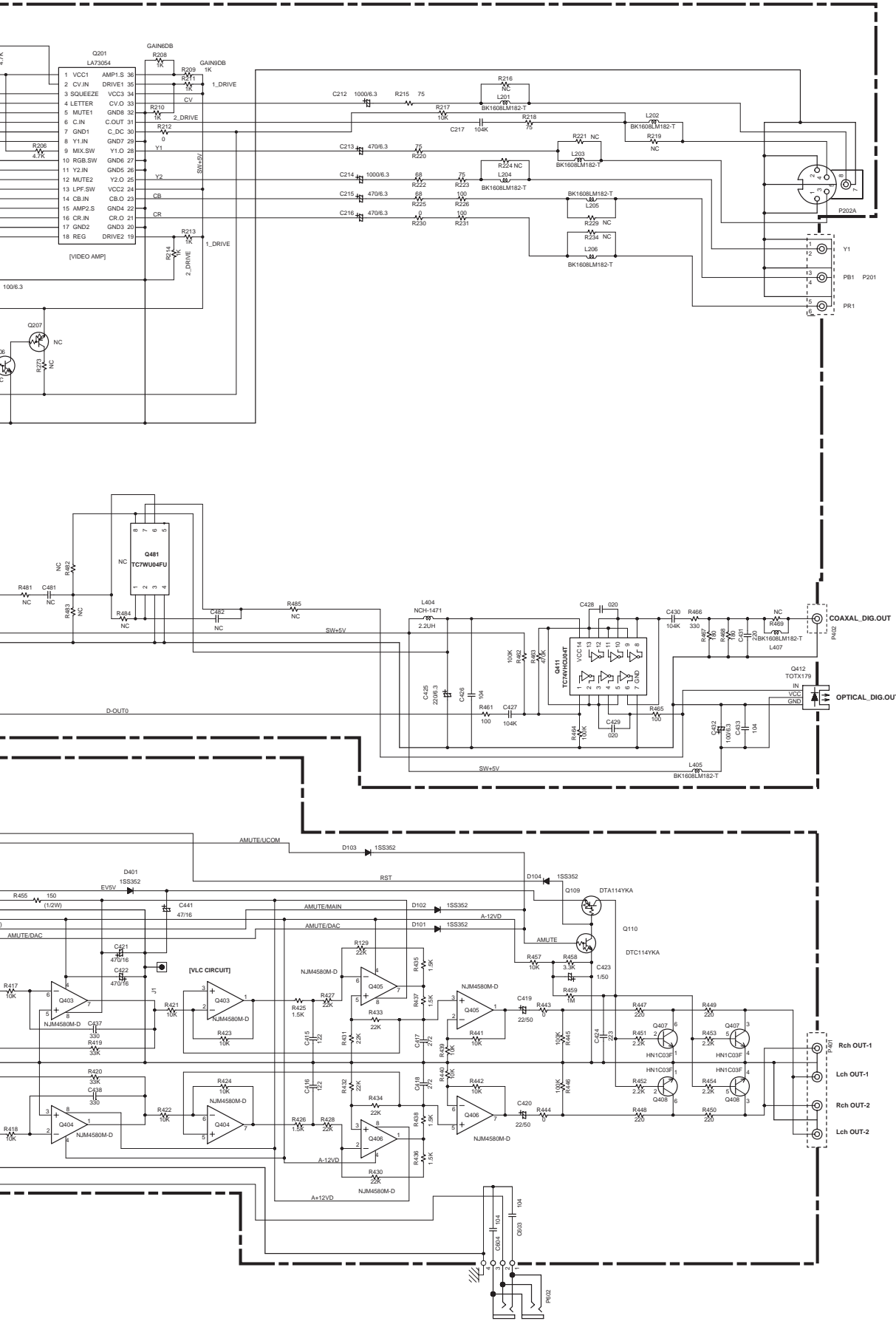

SCHEMATIC DIAGRAM

U14: POWER SUPPLY UNIT (NGPS-0036-100-120V <MDD>)
(NGPS-0037-100-240V <MPA>)

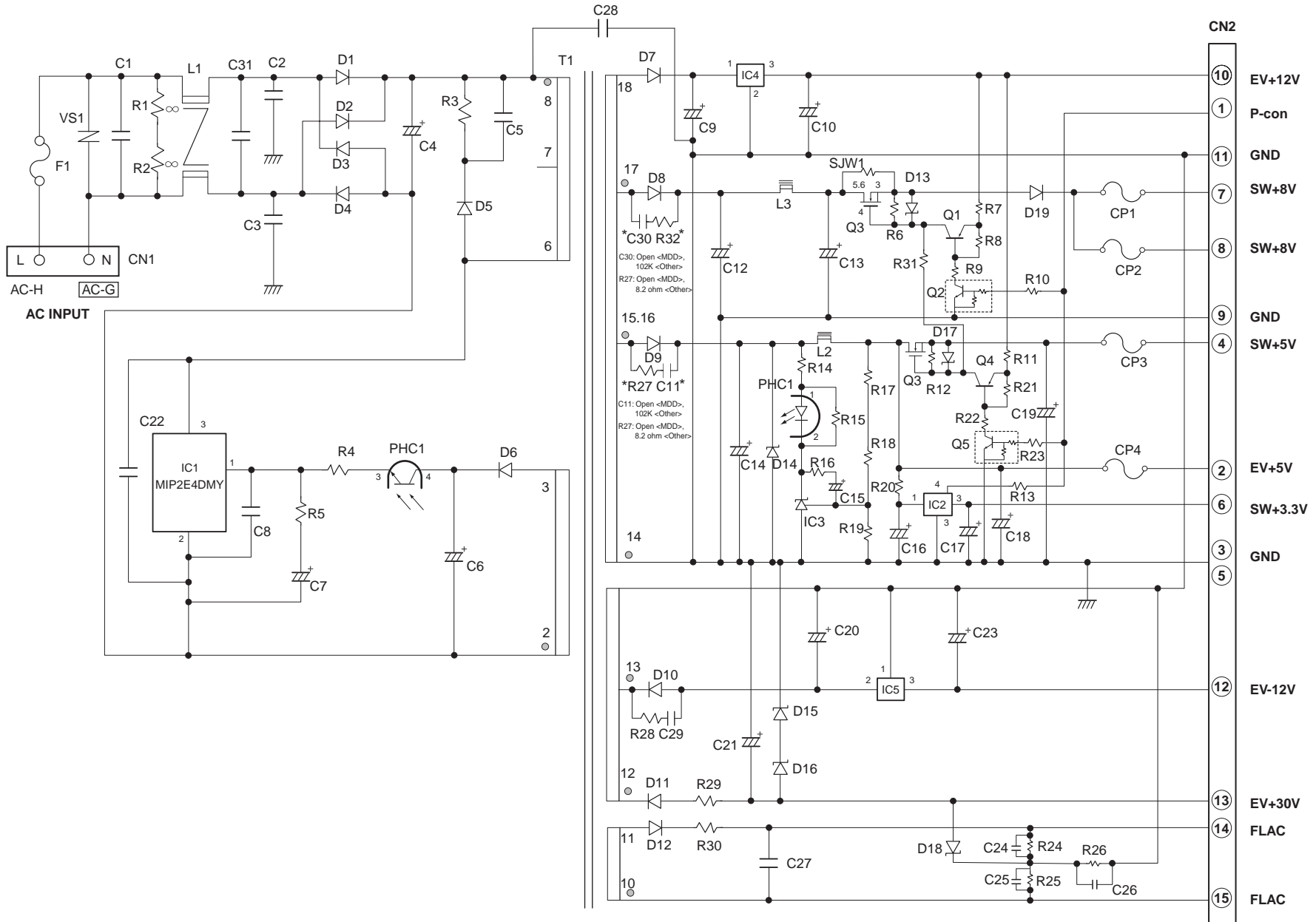

WIRING VIEW

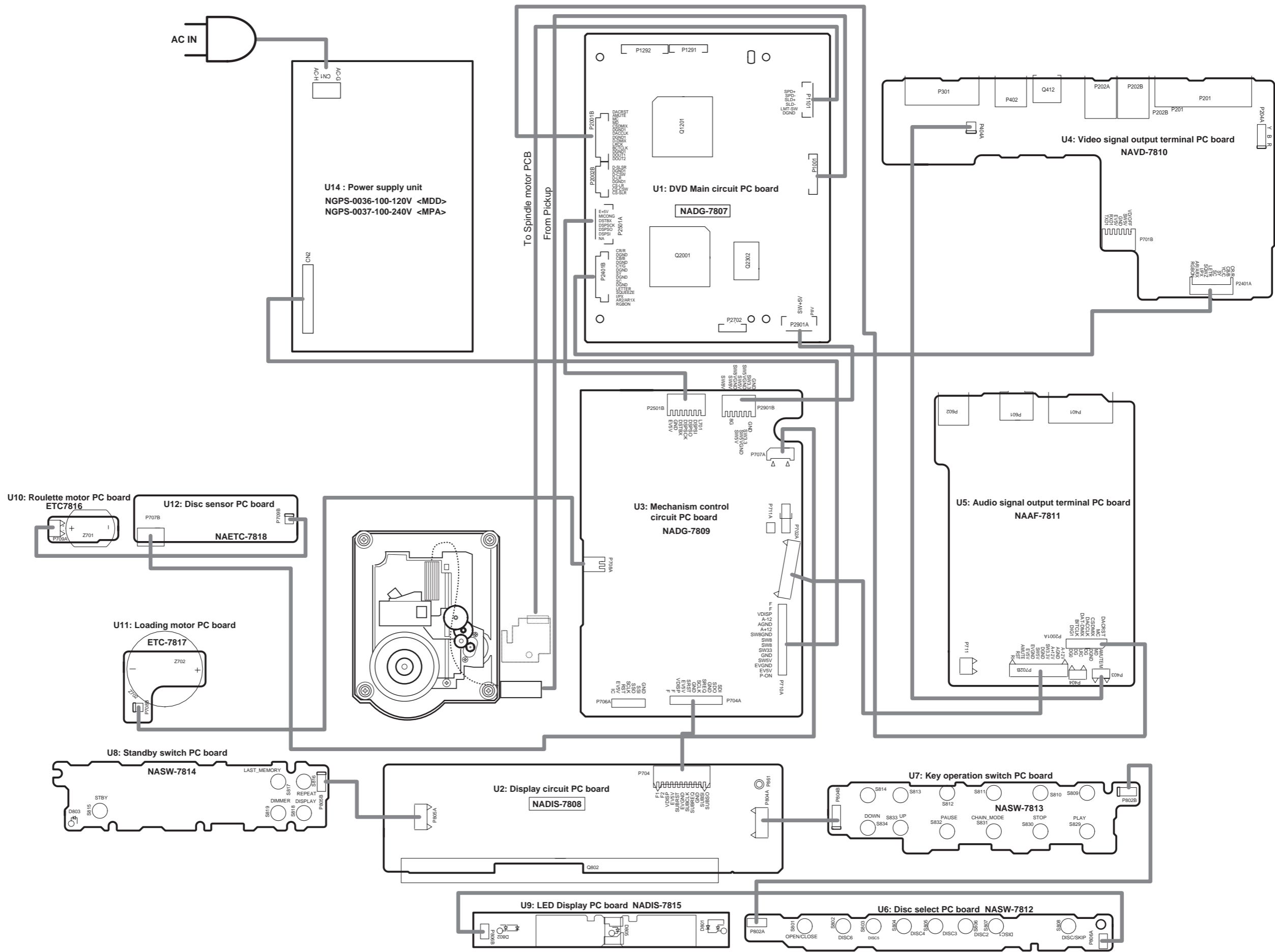

A B C D
PRINTED CIRCUIT BOARD VIEW

U1: DVD MAIN CIRCUIT PC BOARD (NADG-7807)

1

2

3

4

5

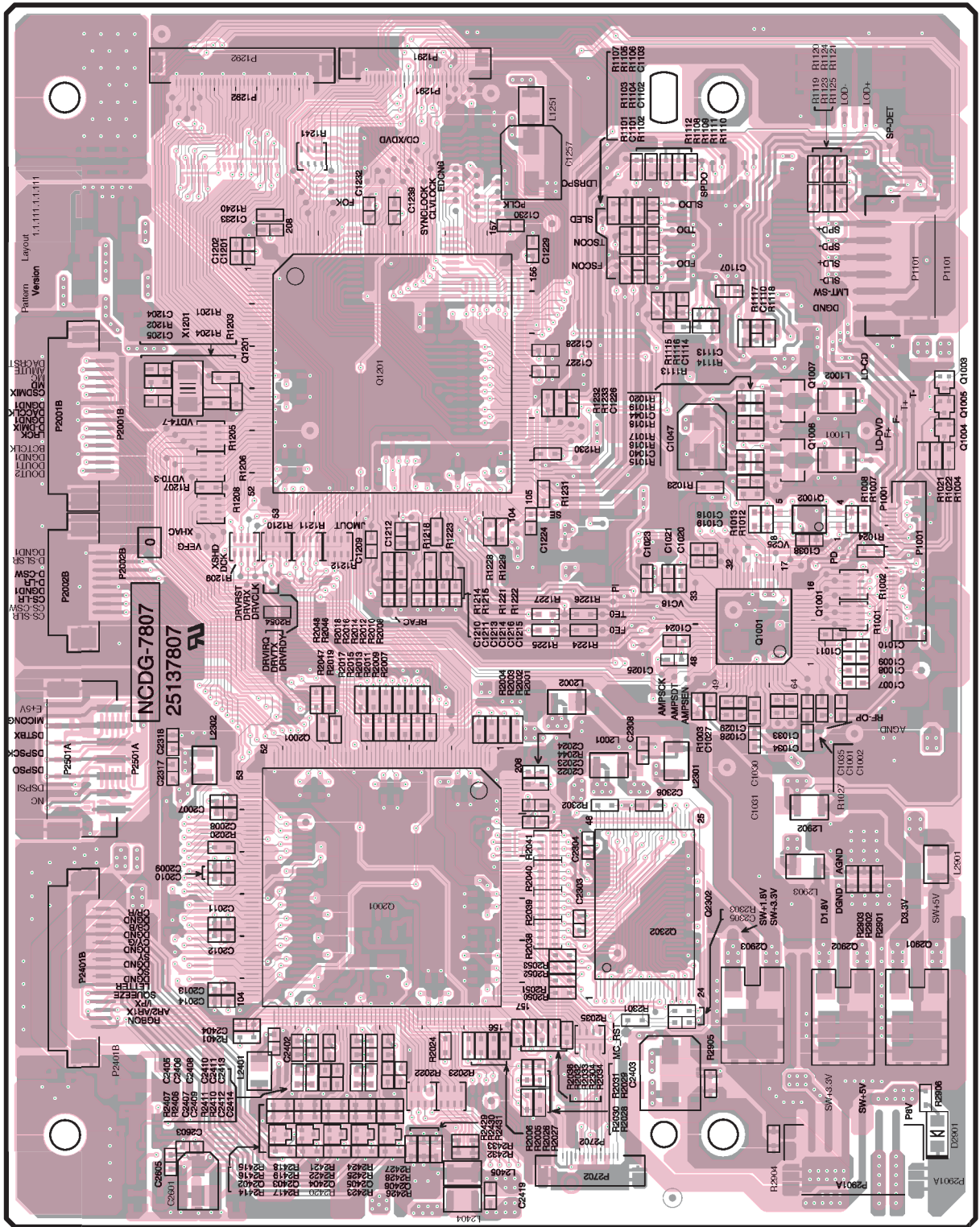

: Side A pattern
 : Side B pattern

A B C D

PRINTED CIRCUIT BOARD VIEW

U1: DVD MAIN CIRCUIT PC BOARD (NADVG-7807)

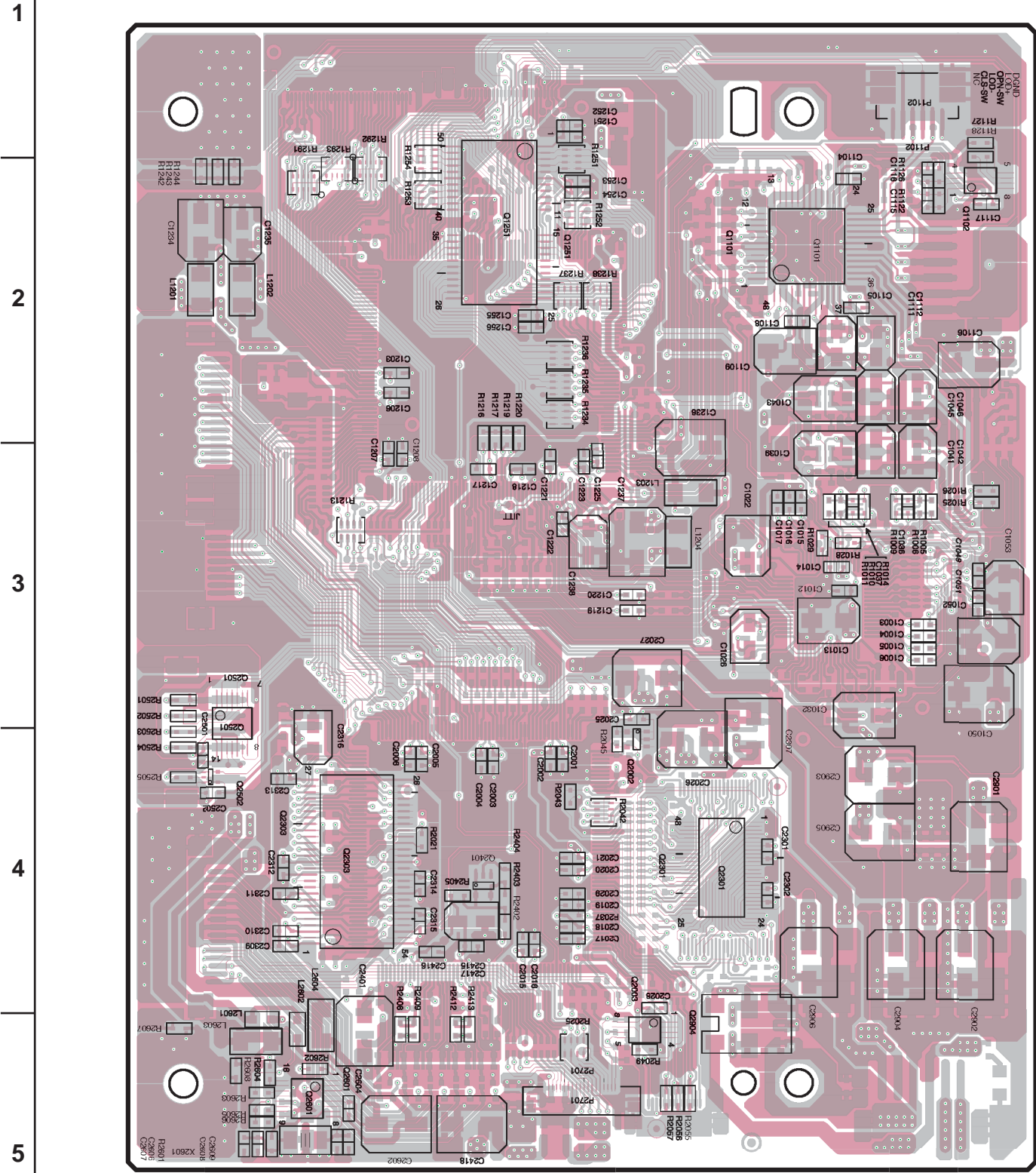

■ : Side B pattern
 ■ : Side A pattern

A

B

C

D

PRINTED CIRCUIT BOARD VIEW FROM SOLDERING SIDE

U2: DISPLAY CIRCUIT PC BOARD (NADIS-7807)

1

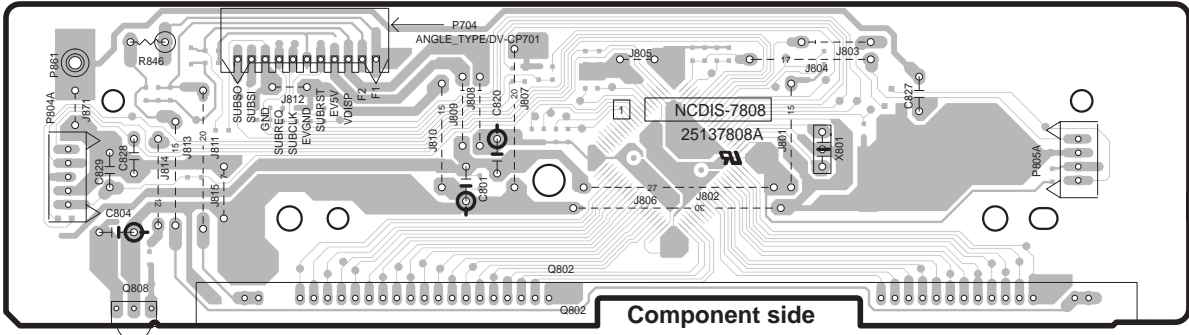

2

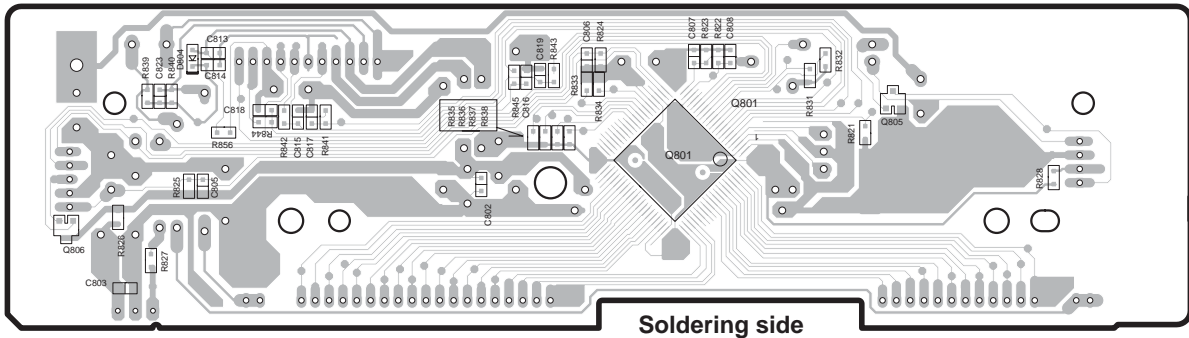

3

(U8) : STANDBY SWITCH PC BOARD (NASW-7814)

4

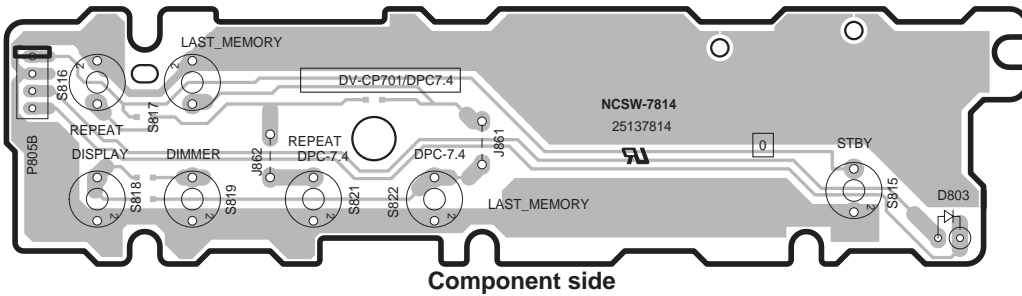

5

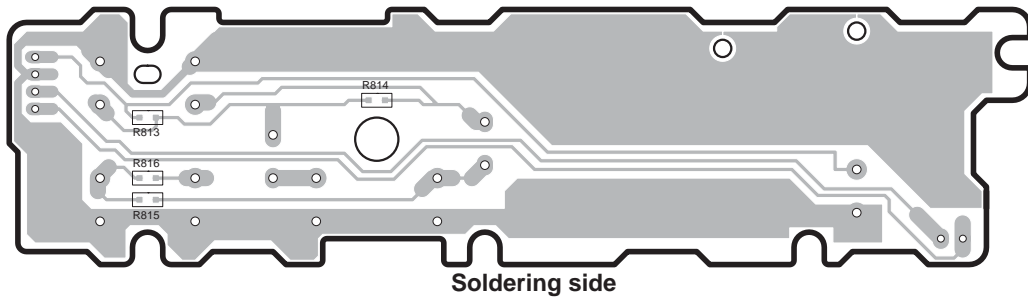

A

B

C

D

PRINTED CIRCUIT BOARD VIEW FROM BOTTOM SIDE

U5: AUDIO SIGNAL OUTPUT TERMINAL PC BOARD (NAAF-7811)

1

2

3

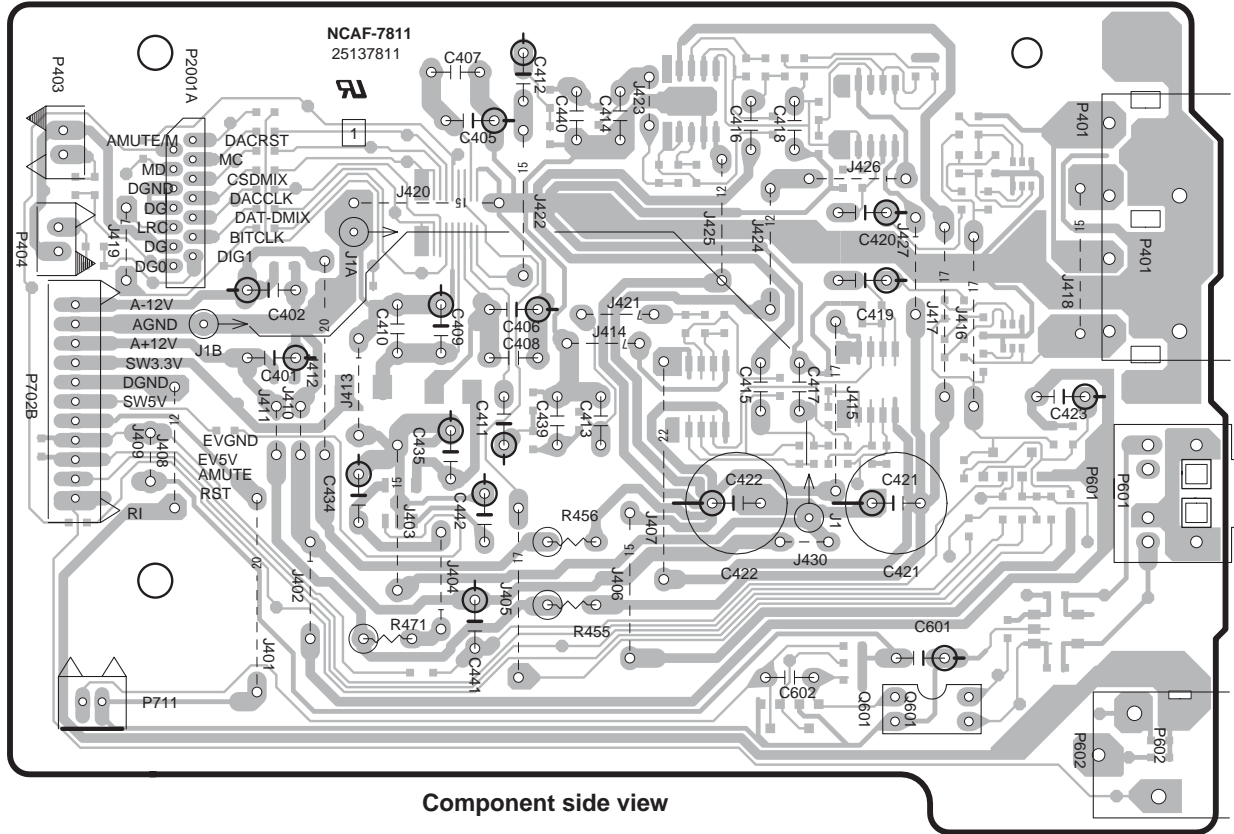

Component side view

4

5

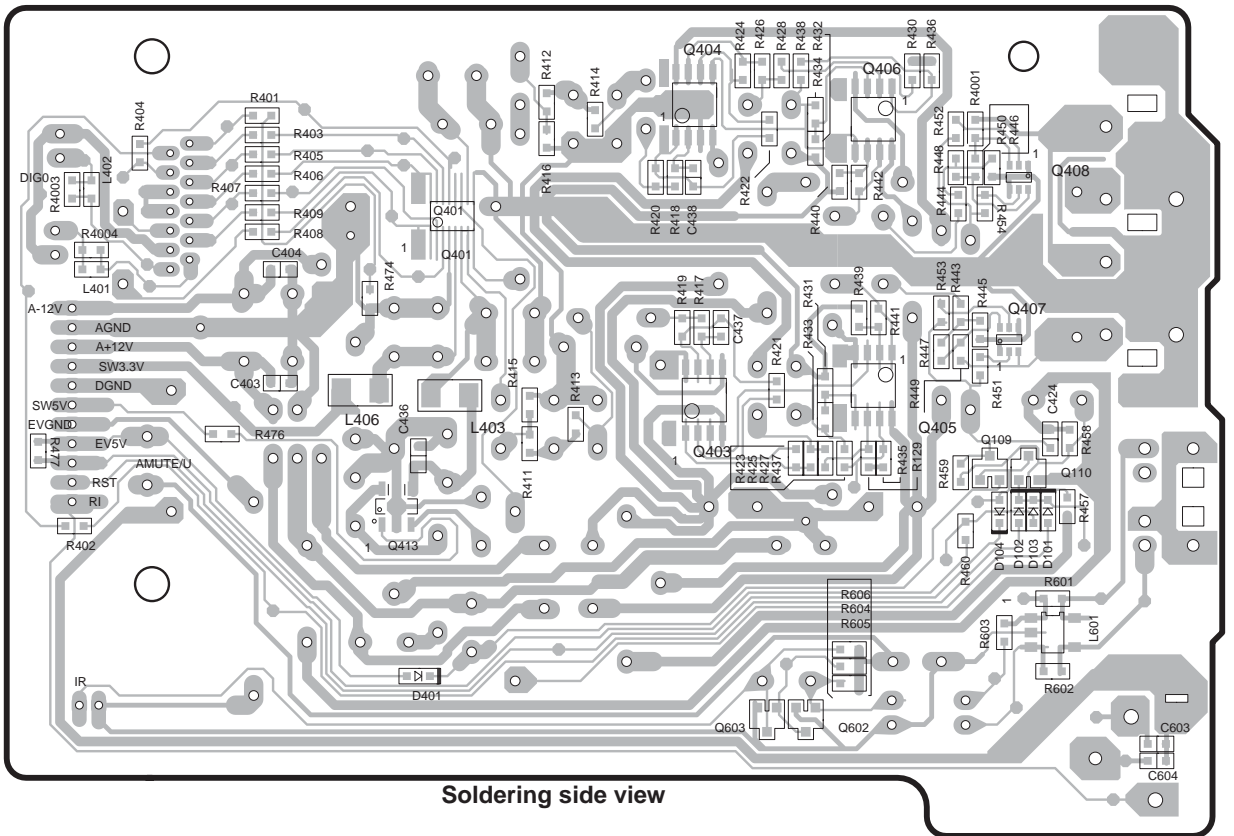

Soldering side view

A

B

C

D

PRINTED CIRCUIT BOARD VIEW FROM SOLDERING SIDE

1

(U6): DISC SELECT SWITCH PC BOARD (NASW-7812)

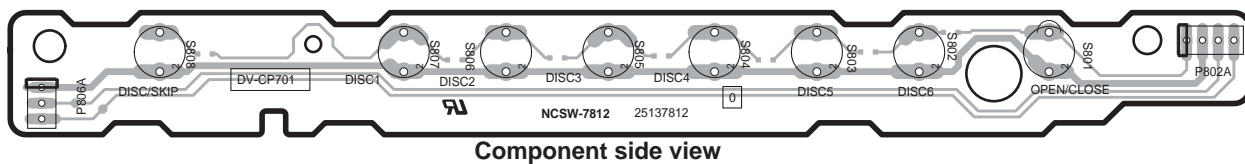

2

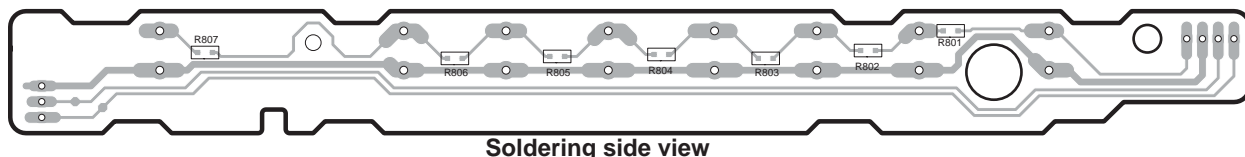

3

(U7): KEY OPERATION SWITCH PC BOARD (NASW-7813)

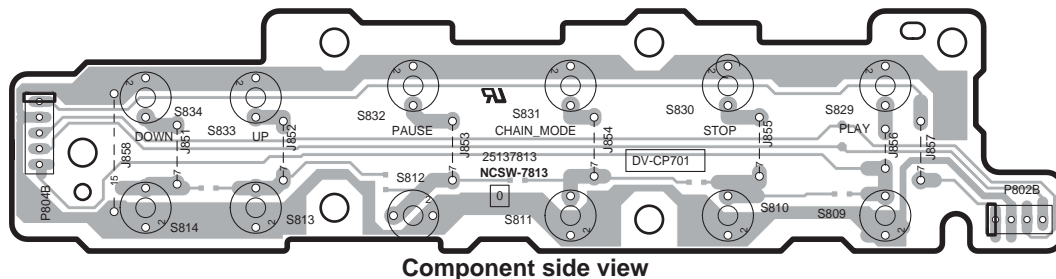

4

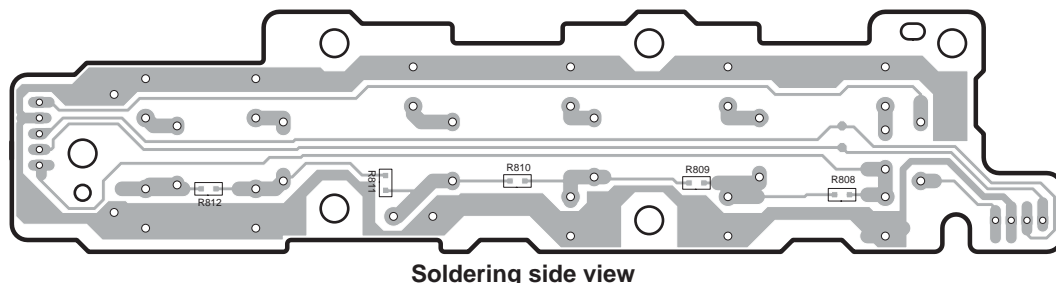

5

(U9): STANDBY SWITCH PC BOARD (NASW-7814)

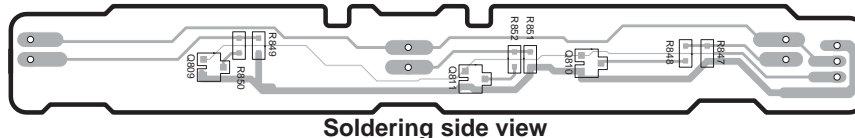
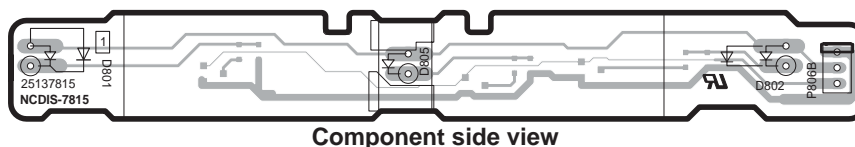

A

B

C

D

PRINTED CIRCUIT BOARD VIEW FROM SOLDERING SIDE

1

(U12) : DISC SENSOR PC BOARD (NAETC-7818)

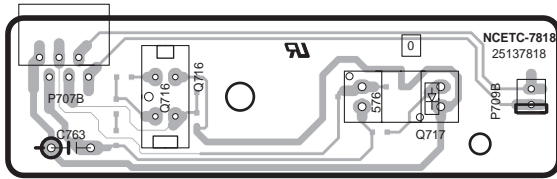

Component side view

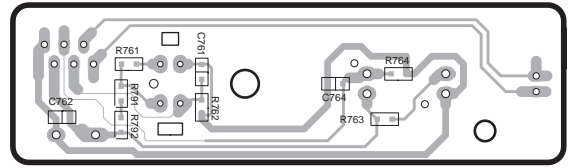

Soldering side view

2

(U11) : LOADING MOTOR PC BOARD (NAETC-7817)

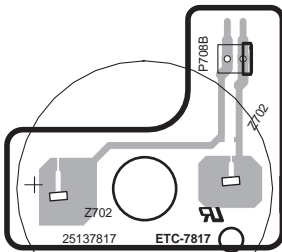

Component side view

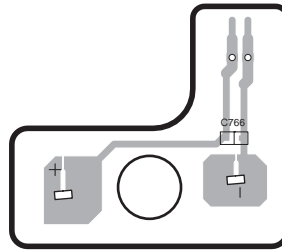

Soldering side view

3

(U10) : ROULETTE MOTOR PC BOARD (NAETC-7816)

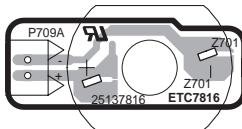

Component side view

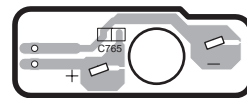

Soldering side view

4

5

A

B

C

D

PRINTED CIRCUIT BOARD VIEW FROM SOLDERING SIDE

(U4) : VIDEO SIGNAL OUTPUT TERMINAL PC BOARD (NAVD-7810)

1

2

3

4

5

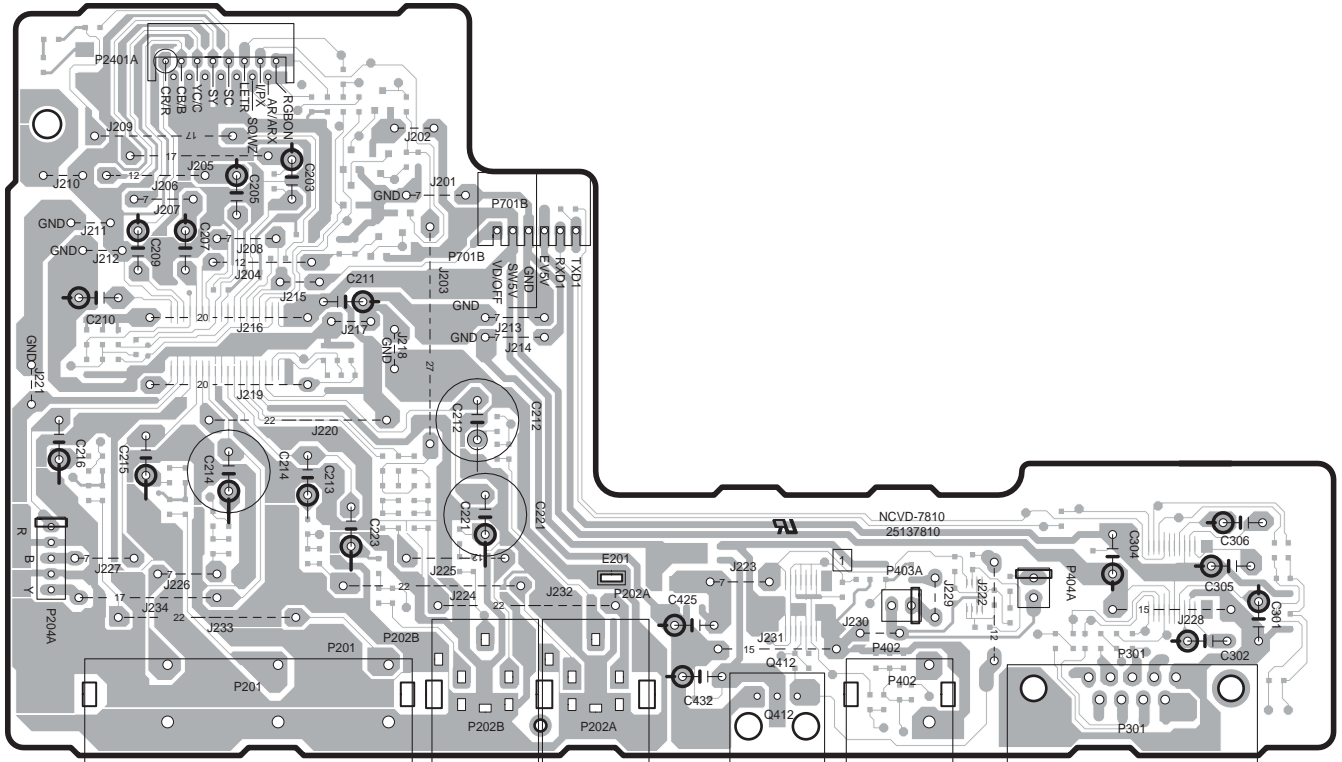

Component side

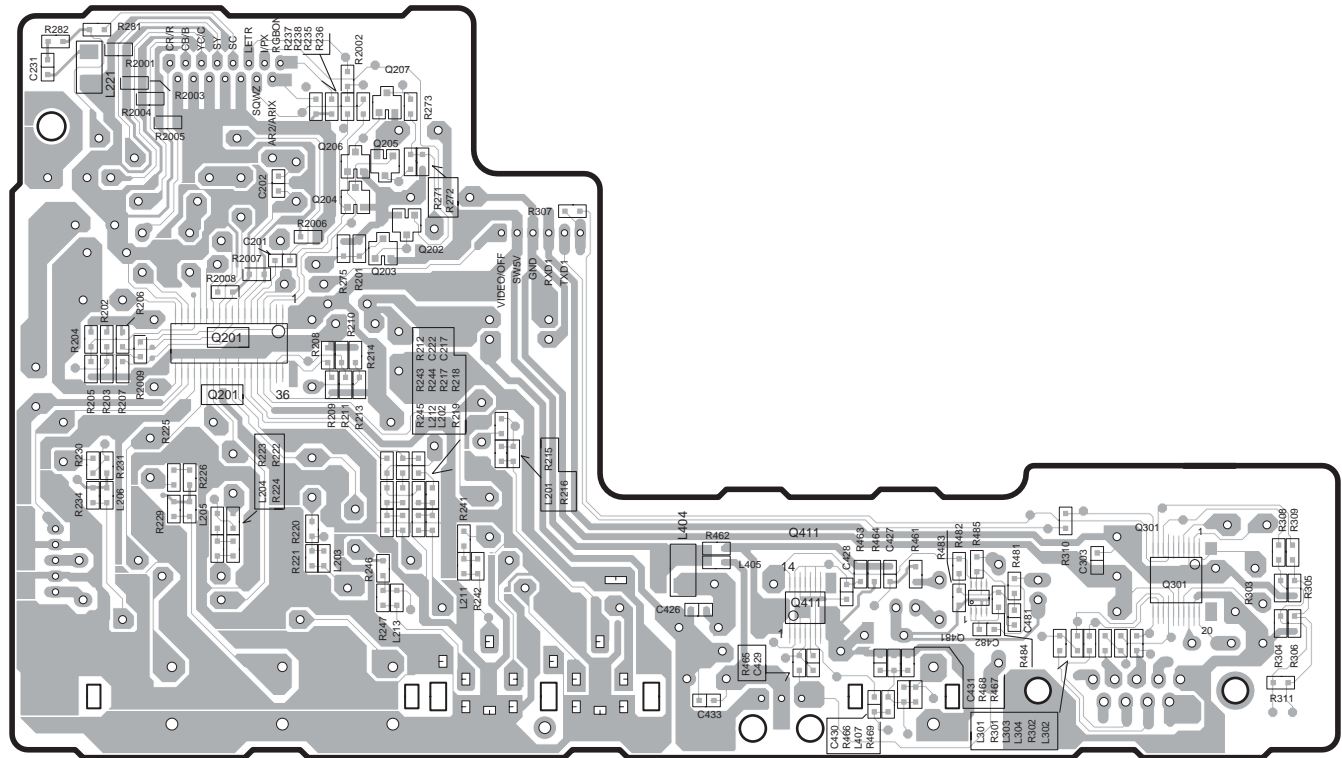

Soldering side

IC BLOCK DIAGRAM/ TERMINAL DESCRIPTION

Q1101: FAN8042 5-CH MOTOR DRIVER-1

PIN ASSIGNMENT

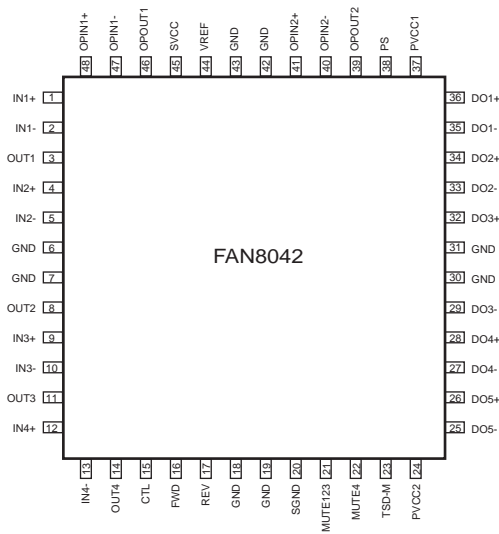

PIN DEFINITION

Pin Number	Pin Name	I/O	Pin Function description
1	IN1+	I	CH1 op-amp input (+)
2	IN1-	I	CH1 op-amp input (-)
3	OUT1	O	CH1 op-amp output
4	IN2+	I	CH2 op-amp input (+)
5	IN2-	I	CH2 op-amp input (-)
6	GND	-	Ground
7	GND	-	Ground
8	OUT2	O	CH2 op-amp output
9	IN3+	I	CH3 op-amp input (+)
10	IN3-	I	CH3 op-amp input (-)
11	OUT3	O	CH3 op-amp output
12	IN4+	I	CH4 op-amp input (+)
13	IN4-	I	CH4 op-amp input (-)
14	OUT4	O	CH4 op-amp output
15	CTL	I	CH5 motor speed control
16	FWD	I	CH5 forward input
17	REV	I	CH5 reverse input
18	GND	-	Ground
19	GND	-	Ground
20	SGND	-	Signal Ground
21	MUTE123	I	Mute for CH1,2,3
22	MUTE4	I	Mute for CH4
23	TSD-M	O	TSD monitor
24	PVCC2	-	Power supply voltage 2 (For CH4, CH5)
25	DO5-	O	CH5 driver output (-)
26	DO5+	O	CH5 driver output (+)
27	DO4-	O	CH4 driver output (-)
28	DO4+	O	CH4 driver output (+)
29	DO3-	O	CH3 driver output (-)
30	GND	-	Ground
31	GND	-	Ground
32	DO3+	O	CH3 driver output (-)
33	DO2-	O	CH2 driver output (-)
34	DO2+	O	CH2 driver output (+)
35	DO1-	O	CH1 driver output (-)
36	DO1+	O	CH1 driver output (+)
37	PVCC1	-	Power supply voltage 1 (For CH1, CH2, CH3)
38	PS	I	Power save
39	OPOUT2	O	Normal op-amp2 output
40	OPIN2-	I	Normal op-amp2 input (-)
41	OPIN2+	I	Normal op-amp2 input (+)
42	GND	-	Ground
43	GND	-	Ground
44	VREF	I	Bias voltage input
45	SVCC	-	Signal & op-amps supply voltage
46	OPOUT1	O	Normal op-amp1 output
47	OPIN1-	I	Normal op-amp1 input (-)
48	OPIN1+	I	Normal op-amp1 input (+)

IC BLOCK DIAGRAM/ TERMINAL DESCRIPTION

Q1101: FAN8042 5-CH MOTOR DRIVER-2

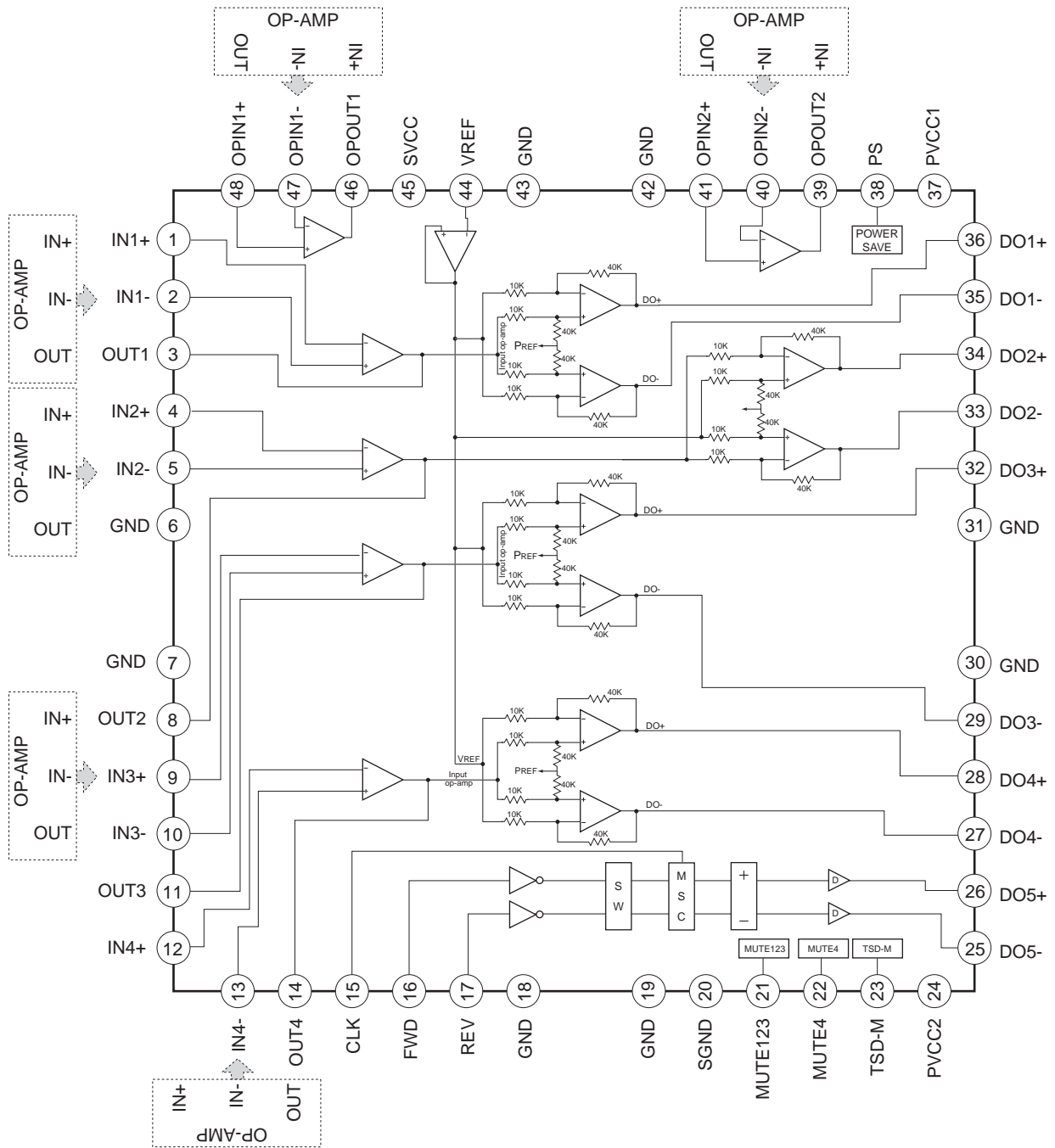

IC BLOCK DIAGRAM/ TERMINAL DESCRIPTION

Q2502: TC7SZ125FU (BUS BUFFER 3-STAGE OUTPUT)

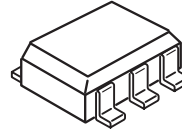
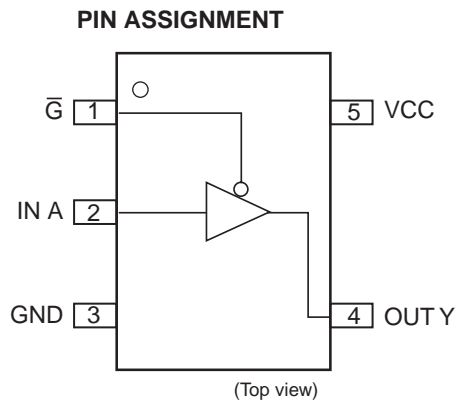

Truth table

INPUT		OUTPUT
A	G	Y
X	H	Z
L	L	L
H	L	H

X: Don't care

Z: High impedance

IC BLOCK DIAGRAM / TERMINAL DESCRIPTION

Q411 : TC74VHC04FT Hex inverter

Pin layout

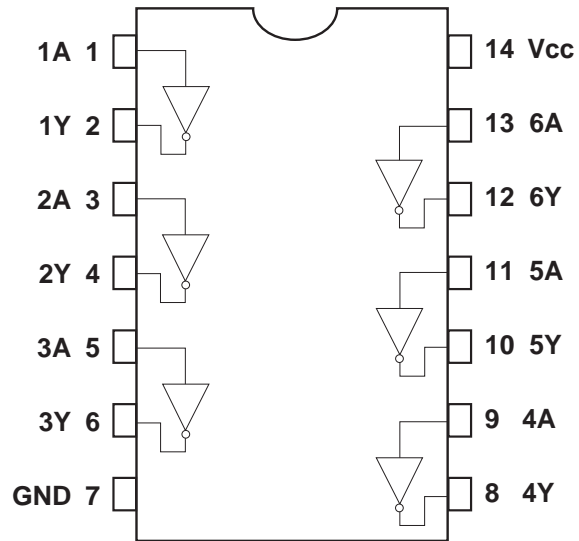

Truth table

A	Y
L	H
H	L

IC BLOCK DIAGRAM/ TERMINAL DESCRIPTION

Q2501: TC74VHCT125AF QUAD BUS BUFFER

Pin Assignment

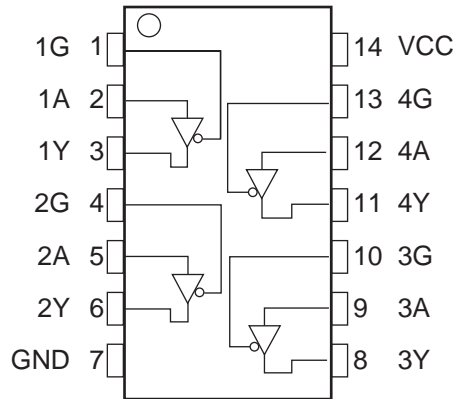

Truth Table

INPUTS		OUTPUTS
\bar{G}	A	Y
H	X	Z
L	L	L
L	H	H

X: Don't Care

Z: High Impedance

IC BLOCK DIAGRAM/ TERMINAL DESCRIPTION

Q2301: TC74VCX162373FT 16-BIT D-TYPE LATCH

PIN ASSIGNMENT

1OE	1	48	1LE
1Q1	2	47	1D1
1Q2	3	46	1D2
GND	4	45	GND
1Q3	5	44	1D3
1Q4	6	43	1D4
VCC	7	42	VCC
1Q5	8	41	1D5
1Q6	9	40	1D6
GND	10	39	GND
1Q7	11	38	1D7
1Q8	12	37	1D8
2Q1	13	36	2D1
2Q2	14	35	2D2
GND	15	34	GND
2Q3	16	33	2D3
2Q4	17	32	2D4
VCC	18	31	VCC
2Q5	19	30	2D5
2Q6	20	29	2D6
GND	21	28	GND
2Q7	22	27	2D7
2Q8	23	26	2D8
2OE	24	25	2LE

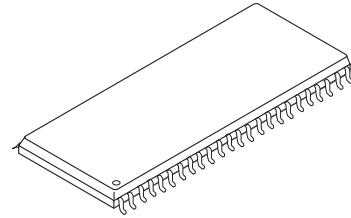

SYSTEM DIAGRAM

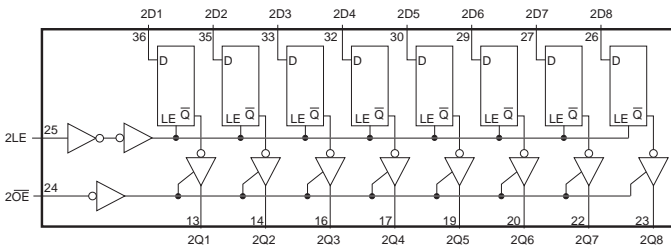
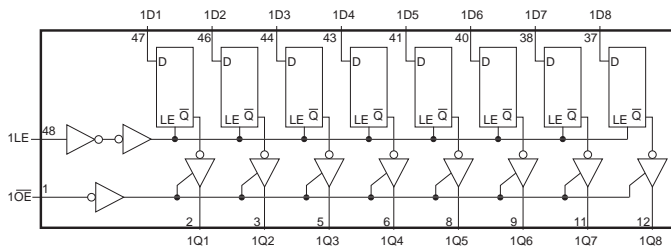

Truth Table

Inputs			Outputs
1OE	1LE	1D1-1D8	1Q1-1Q8
H	X	X	Z
L	L	X	Qn
L	H	L	L
L	H	H	H

Inputs			Outputs
2OE	2LE	2D1-2D8	2Q1-2Q8
H	X	X	Z
L	L	X	Qn
L	H	L	L
L	H	H	H

X: Don't care

Z: High impedance

Qn: Q output are latched at the time

when the LE input is taken to a low logic level.

IC BLOCK DIAGRAM/ TERMINAL DESCRIPTION

Q704, Q705: TA7291S (MOTOR DRIVER)

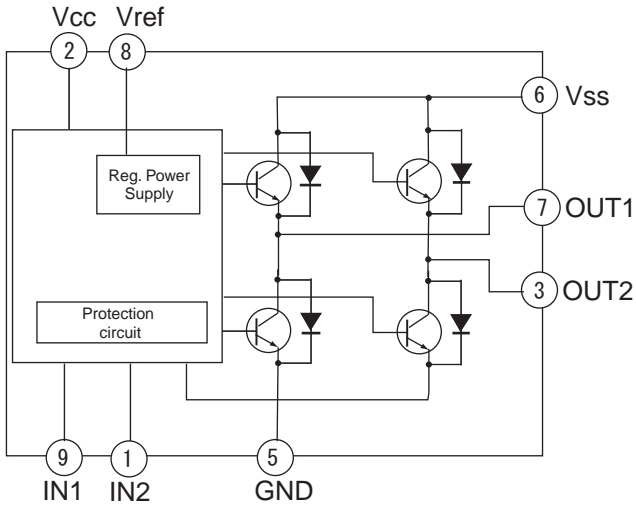

INPUT		OUTPUT		MODE
IN1	IN2	OUT1	OUT2	
0	0	∞	∞	STOP
1	0	H	L	CW/CCW
0	1	L	H	CCW/CW
1	1	L	L	BRAKE

CW: Clockwise direction
 CCW: Counter clockwise direction

IC BLOCK DIAGRAM/ TERMINAL DESCRIPTION

Q2002: S-80127CNMC-JKM VOLTAGE DETECTOR (12.7V N-ch open drain, Active L: out)

Q702: S-80130CLMC-JKM VOLTAGE DETECTOR (13.0V CMOS, Active L: out)

PIN CONFIGURATION

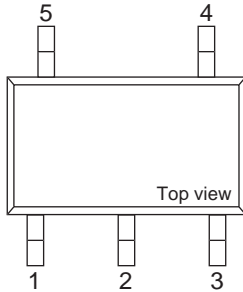

PIN DESCRIPTION

No.	Symbol	Description
1	DS	ON/OFF switch for delay time
2	VSS	GND
3	NC ^{*1}	Non-connection
4	OUT	Voltage detection output pin
5	VDD	Voltage input pin

*1. NC pin is electrically open.

BLOCK DIAGRAM

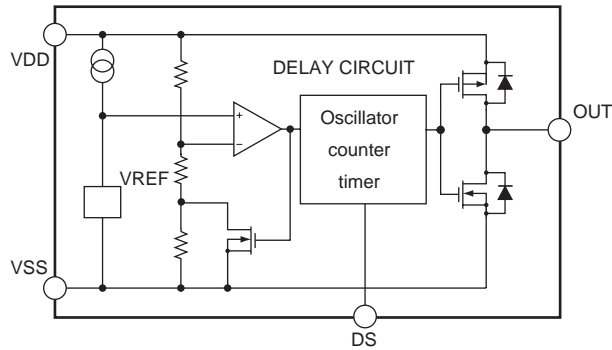

IC BLOCK DIAGRAM/ TERMINAL DESCRIPTION

Q401: PCM1742KE DIGITAL-TO-ANALOG CONVERTER

24-Bit, 192kHz Sampling

Enhanced Multilevel, Delta-Sigma, Audio

BLOCK DIAGRAM

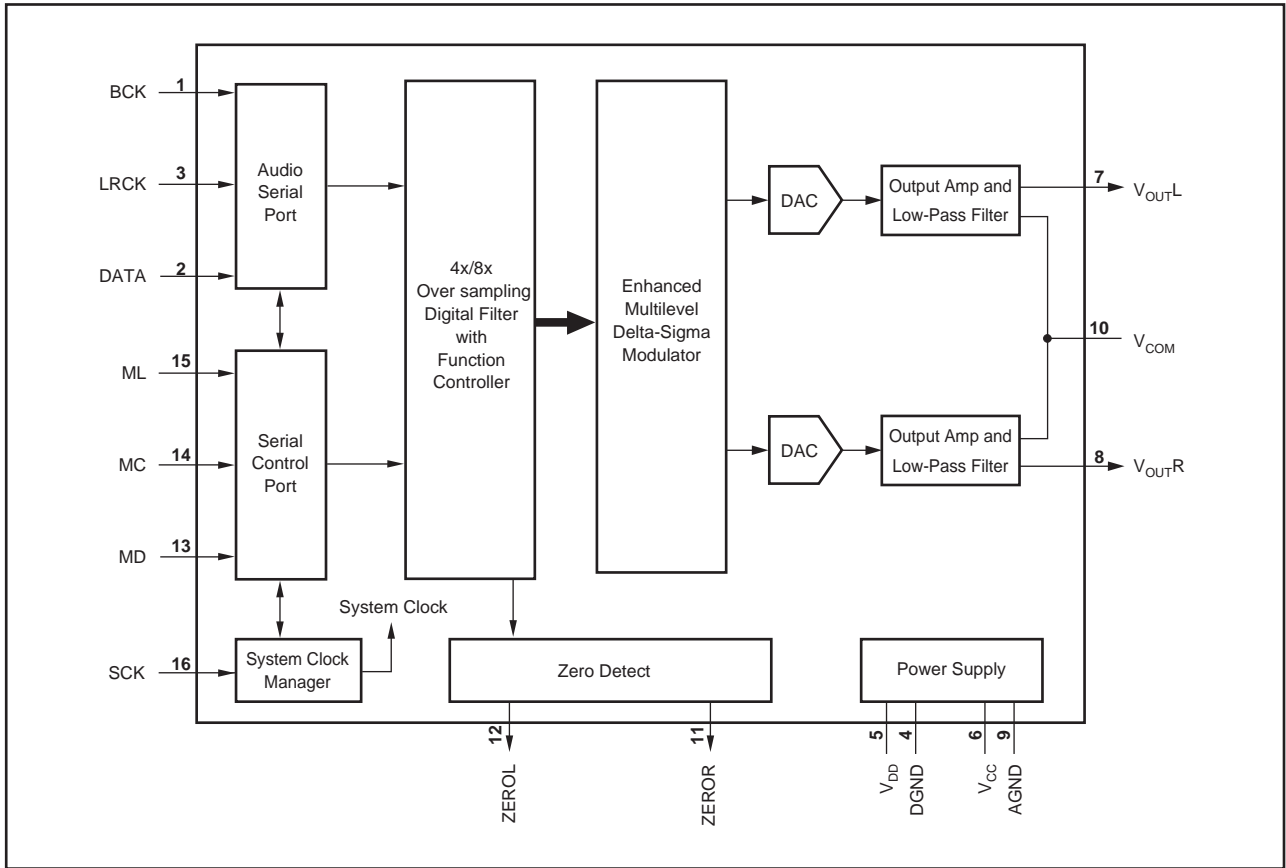

PIN CONFIGURATION

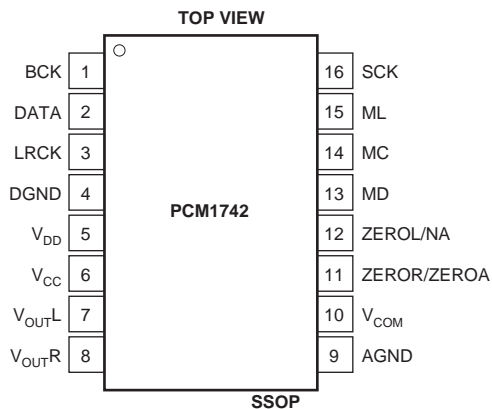

PIN ASSIGNMENTS

PIN	NAME	TYPE	FUNCTION
1	BCK	IN	Audio Data Bit Clock Input. ⁽¹⁾
2	DATA	IN	Audio Data Digital Input. ⁽¹⁾
3	LRCK	IN	L-Channel and R-Channel Audio Data Latch Enable Input. ⁽¹⁾
4	DGND	-	Digital Ground
5	V _{DD}	-	Digital Power Supply, +3.3V
6	V _{CC}	-	Analog Power Supply, +5V
7	V _{OUTL}	OUT	Analog Output for L-Channel.
8	V _{OUTR}	OUT	Analog Output for R-Channel.
9	AGND	-	Analog Ground
10	V _{COM}	-	Common Voltage Decoupling.
11	ZEROR/ ZEROA	OUT	Zero Flag Output for R-Channel/Zero Flag Output for L/R-Channel.
12	ZEROL/NA	OUT	Zero Flag Output for L-Channel/No Assign.
13	MD	IN	Mode Control Data Input. ⁽²⁾
14	MC	IN	Mode Control Clock Input. ⁽²⁾
15	ML	IN	Mode Control Latch Input. ⁽²⁾
16	SCK	IN	System Clock Input.

NOTES: (1) Schmitt-trigger input, 5V tolerant. (2) Schmitt-trigger with internal pull-down, 5V tolerant.

EXPLODED VIEW PARTS LIST

!: Safety part

REF. NO.	PART NAME	DESCRIPTION	PART NO.
A01	Front Panel		1466-1801-0
A01	Front Panel	<S>	1466-1802-0
A02	KNOB (STBY)		2446-3901-0
A02	KNOB (STBY)	<S>	2446-3701-0
A03	KNOB (SEL)		2446-4101-0
A03	KNOB (SEL)	<S>	2446-3801-0
A04	KNOB (EJECT)		2446-4601-0
A04	KNOB (EJECT)	<S>	2446-4401-0
A05	KNOB (PLAY)		2446-4301-0
A05	KNOB (PLAY)	<S>	2446-4001-0
A06	KNOB (DISPLAY)		2446-4501-0
A06	KNOB (DISPLAY)	<S>	2446-4201-0
A07	Retainer	(BDG)	4135-3701-0
A08	Badge		28135244
A08	Badge	<S>	28135245
A12	Clear Plate		3716-8411-0
A12	Clear Plate	<S>	3716-8211-0
A13	Facet	(LIGHT)	3716-8306-0
A14	Facet	(S)	3716-8511-0
A15	Spacer		27270437
A18	Front Bracket	(F)	4135-3181-0
A19	Tapping Screw	2.6TTB+8B(BC)	838426088
A21	Isolation Sheet		4154-6191-0
A22	Plastic Rivet	P-3055B-BL	880048
A25	Tapping Screw	3TTB+8B	838130088
A26	Tapping-tighten screw with washer	3TTW+8B(BC)	831430088
A30	Chassis		1404-7601-0
A31	Holder	KGLS-10RF	27190428A
A32	Clamper	CLAMP WS-2W	27300243
A33	Retainer	(R)	4135-3191-0
A41	Foot	LEG	27175316C
A42	Cushion		4157-0311-0
A46	Cushion		4149-0401-0
A48	Cord Bushing	S-RELIEF #2271	27300750
A50	Tray Panel		4154-6121-0
A50	Tray Panel	<S>	4154-6122-0
A53	Rear Panel	<BMDD>	1404-7501-0
A53	Rear Panel	<BMPA>	1404-7502-0
A53	Rear Panel	<SMDD>	1404-7501-0
A54	Tapping Screw	3TTB+8B(BC)	838430088
A56	Label	(DVD2)	3000-9443-0
A58	Label	(ROM)	29362727
A59	Cushion		28141541
A214	Top Cover		1404-7401-0
A215	Tapping Screw	3TTB+8B(BC) 	838430088
A215	Tapping Screw	3TTB+8B(UN) <S>	838930088
E102	Wire tie		260259
E821	Ferrite Core	GM8T25*15*10	1808-0740-0
F001	Fuse	1.6A-UL/T-237 <MDD>	252158
F001 or	Fuse	1.6A-T/UL-ST2 <MDD>	252252
F001	Fuse	2.5A-SE-EAK FUSE <MPA>	252075
F001 or	Fuse	2.5A-SE-TL250V <MPA>	252275
P1001	FFC	NCFC5-26003	7012-6553-0
P1101	Connector assy	NSAS-12P0960	20022391210UL
P2001	FFC	NCFC5-141522	7012-6525-0
P2401	FFC	NCFC5-152022	7012-6526-0
P2501	Connector assy	NSAS-14P1093	7012-6527-0
P2901	Connector assy	NSAS-12P1105	7012-6528-0
P702	Connector assy	NSAS-22P1141	7012-6521-0

P707	FFC	NCFC6-063012	7012-6522-0	
P901	Power cord	AS-UC-2 <MDD>	253333VOL	
P901 or	Power cord	AS-UC-2 <MDD>	253332HIT	
P901	Power cord	AS-SAA <MPA>	253197HIT	
P901 or	Power cord	AS-SAA <MPA>	253307VOL	GPE P/N
U1	DVD Main circuit PC board assy	NADG-7807A-1A <MDD, MPA>	1H498507-1A	SVC-7807-1A
U2	Display circuit PC board assy	NADIS-7808-1A <MDD>	SVC-Q0090C-1A	
U2	Display circuit PC board assy	NADIS-7808-1B <MPA>	SVC-Q0090C-1B	
U14	Power supply unit	NGPS-0036-100-120V <MDD>	8910-0740-0	
	Power supply unit	NGPS-0036-100-240V <MPA>	8910-0750-0	
(U2)	Display circuit PC board assy	NADIS-7808-1A <MDD>	1H498508-1A	
(U2)	Display circuit PC board assy	NADIS-7808-1B <MPA>	1H498508-1B	
(U3)	Mechanism control circuit PC board assy	NADG-7809-1A <MDD>	1H498509-1A	
(U3)	Mechanism control circuit PC board assy	NADG-7809-1A <MPA>	1H498509-1B	
(U4)	Video signal output terminal PC board	NAVD-7810-1A <MDD>	1H498510-1A	
(U4)	Video signal output terminal PC board	NAVD-7810-1B <MPA>	1H498510-1B	
(U5)	Audio signal output terminal PC board	NAAF-7811-1A <MDD>	1H498511-1A	
(U5)	Audio signal output terminal PC board	NAAF-7811-1B <MPA>	1H498511-1B	
(U6)	Disc select switch PC board assy	NASW-7812-1A <MDD>	1H498512-1A	
(U6)	Disc select switch PC board assy	NASW-7812-1B <MPA>	1H498512-1B	
(U7)	Key operation switch PC board assy	NASW-7813-1A <MDD>	1H498513-1A	
(U7)	Key operation switch PC board assy	NASW-7813-1B <MPA>	1H498513-1B	
(U8)	Standby switch PC board assy	NASW-7814-1A <MDD>	1H498514-1A	
(U8)	Standby switch PC board assy	NASW-7814-1B <MPA>	1H498514-1B	
(U9)	LED display PC board assy	NADIS-7815-1A <MDD>	1H498515-1A	
(U9)	LED display PC board assy	NADIS-7815-1B <MPA>	1H498515-1B	
(U10)	Roulette motor PC board assy	NAETC-7816-1A <MDD>	1H498516-1A	
(U10)	Roulette motor PC board assy	NAETC-7816-1B <MPA>	1H498516-1B	
(U11)	Loading motor PC board assy	NAETC-7817-1A <MDD>	1H498517-1A	
(U11)	Loading motor PC board assy	NAETC-7817-1B <MPA>	1H498517-1B	
(U12)	Disc sensor PC board assy	NAETC-7818-1A <MDD>	1H498518-1A	
(U12)	Disc sensor PC board assy	NAETC-7818-1B <MPA>	1H498518-1B	

: Black color model
<S>: Silver color model
<MDD>: North American and Canadian area only
<MPA>: Australian area only
NSP: Not Service Parts

PACKING PARTS LIST

REF. NO.	PART NAME	DESCRIPTION	PART NO.	
A602	Polyform	L-SIDE	1490-4181-0	29092094A
A603	Polyform	R-SIDE	1490-4191-0	29092095A
A604	Sheet	(DR)	29095795	
A606	Bag		1450-6910-0	29100207
A608	Tape	NITTO NO.29	29110149	
A610	PP Tape	W48 OPP TAPE	29110148	
A651	UPC Label	<B MDD>	3000-9445-0	29363364
A651	EAN Label	<B MPA>	3000-9442-0	29363366
A651	UPC Label	<S MDD>	3000-9631-0	29363365
A652	Warranty Card	<MDD>	29365090A	
A653	Instruction Sheet	(PAC)	29355299	
A655	Carton Box	<B MDD>	1436-2901-0-1	29054026B
A655	Carton Box	<B MPA>	1436-2903-0-1	29054028
A655	Carton Box	<S MDD>	1436-2902-0-1	29054027
E801	Video/ Audio Cable	RCA3P (YWR)	2010379	
E802	Battery	R6/AA(UM-3)	3010054	
E803	Mini Plug Cable	3.5-MINI PLUG (RI)	2010200	

E804	S- Cable	(S CORD)	2010380	
E804 or	S- Cable	TPX3000	2010360	
E805	Remote Controller	RC-542DV	8912-0036-0	24140542
E810	Instruction Manual	E (DVCP701)	4301-7046-0	29343461A

<**B**>: Black color model

<**S**>: Silver color model

<**MDD**>: North American and Canadian area only

<**MPA**>: Australian area only

CHANGER MECHANISM PARTS LIST

REF. No.	PART NAME	DESCRIPTION	PART No.	
M01	Rail		4154-6031-0	24840157A
M02	Loading motor assy	M002+M003	Q0090C-MOTCC	
M03	Tapping screw	3TTB+8B	838130088	
M04	Screw	2.6TTP+4S	833126047	
M06	Rubber Belt	DVCP701	4157-0281-0	
M07	Gear	(PULLEY)	4154-6061-0	
M08	Gear	(A)	4154-6091-0	
M09	Gear	(MAIN)	4154-6071-0	248100087A
M10	Gear	(CAM)	4154-6101-0	
M11	Screw		24840111	
M12	DVD Traverse Mechanism	KHM-280AAA	24801016	
M13	Chassis	(SUB)	4154-6041-0	24802051A
M14	Insulator	(A)	4154-6141-0	
M15	Insulator	(B)	4157-0261-0	
M16	Screw		24840111	
M17	Cap	(CHC)	4154-6161-0	
M18	Yoke	(CHB)	4135-3201-0	
M19	Magnet	(CHB)	4135-3211-0	
M23	Spring		2510-3591-0	24820058
M30	Tray		4154-6011-0	24840158A
M31	Bracket assy	(M)	8901-4650-0	
M31a	Bracket	(M)	8901-4650-0	
M31b	Shaft	(M)	24828038	
M32	Roulette motor assy	M032+M033	Q0090C-MOTPW	
M34	PAN head machine screw	2P+3F(BC)	82142003	
M35	Gear	(WHEEL)	4154-5991-0	
M36	Washer	(B)	24834040	
M37	Tapping screw	3TTB+8B	838130088	
M38	Roller	DVCP701	4154-6131-0	
M39	Roulette		4154-6021-0	24840159A
M40	Screw	SCREW	24840111	
M41	Retainer		4135-3881-0	24822044
M42	Cusion		4157-0451-0	28141541
M50	Arm		4154-6051-0	24814025B

PRINTED CIRCUIT BOARD PARTS LIST
U1: DVD MAIN CIRCUIT PC BOARD (NADG-7807)

CIRCUIT NO.	PART NO.	DESCRIPTION	REMARK
ICs			
Q1001	3131-9990-0	CXD1881BR	22241902R3
Q1002	22241676R2	NJM2115V	
Q1101	3132-0020-0	FAN8042	22241905R3
Q1102	3132-0030-0	BA4510FV	22241907R2
Q1201	3132-0040-0	CXD1885Q	22241903R3
Q1251	3132-0050-0	IC41LV16100-50T, EDO-DRAM	22241909R2
Q2001	3132-0060-0	M65783AFP	22241904R3
Q2002	22241642R2	S-80127CNMC-JKM-T2	
Q2003	3132-0290-0	IS24C08-3Z EEPROM	22241951R2
Q2301	3132-0090-0	TC74VCX162373FT	22241896R2
Q2302	3132-0100-0	MX29LV160ABTC-90, Need Prewriting	22241906R3
Q2303	3132-0110-0	IC42S16400-7T, SDRAM	22241910R2
Q2401	3132-0120-0	NJM2373AF	22241897R2
Q2501	3132-0130-0	TC74VHCT125AFT	22241894R2
Q2502	3132-0140-0	TC7SZ125FU	22241895R2
Q2601	3132-0150-0	BU2288FV, Clock gen.	22241911R2
Q2901	22278033ER2NE	MPC29M33T, Regulator	
Q2902	3132-0170-0	MPC2918T, Regulator	22278018ER2NE
Q2903	3132-0170-0	MPC2918T, Regulator	22278018ER2NE
Q2904	22278033ER2NE	MPC29M33T, Regulator	
Transistors			
Q1003	2216520R2	2SK3019	
Q1004	2216520R2	2SK3019	
Q1005	2216520R2	2SK3019	
Q1006	2216400R2	2SB1132	
Q1007	2216400R2	2SB1132	
Q2402	2216410R2	2SA1774	
Q2403	2216410R2	2SA1774	
Q2404	2216410R2	2SA1774	
Q2405	2216410R2	2SA1774	
Q2406	2216410R2	2SA1774	
Capacitors			
C1013	356742209R2	CEWX16V-22M	
C1022	356742209R2	CEWX16V-22M	
C1026	356741009R2	CEWX16V-10M	
C1032	356742209R2	CEWX16V-22M	
C1039	356724709R2	CEWX6.3V-47M	
C1041	356741009R2	CEWX16V-10M	
C1042	356741009R2	CEWX16V-10M	
C1043	356724709R2	CEWX6.3V-47M	
C1045	356741009R2	CEWX16V-10M	
C1046	356741009R2	CEWX16V-10M	
C1047	356742209R2	CEWX16V-22M	
C1050	356721019R2	CEWX6.3V-100M	
C1052	356742209R2	CEWX16V-22M	
C1053	356780109R2	CEWX50V-1M	
C1106	356742209R2	CEWX16V-22M	
C1109	356742209R2	CEWX16V-22M	
C1111	356741009R2	CEWX16V-10M	(DISC judging is slow.)
C1116	332102235R1	CK725BIH-223K1	473K to 223K (#1861)
C1112	356741009R2	CEWX16V-10M	
C1234	356742209R2	CEWX16V-22M	
C1235	356722209R2	CEWX6.3V-22M	
C1236	356721019R2	CEWX6.3V-100M	
C1237	356721019R2	CEWX6.3V-100M	
C1238	356741009R2	CEWX16V-10M	
C1257	356721019R2	CEWX6.3V-100M	
C2026	356721019R2	CEWX6.3V-100M	
C2027	356721019R2	CEWX6.3V-100M	
C2307	356721019R2	CEWX6.3V-100M	
C2316	356741009R2	CEWX16V-10M	
C2401	356721019R2	CEWX6.3V-100M	

C2403	356721019R2	CEWX6.3V-100M
C2415	356741009R2	CEWX16V-10M
C2418	356721019R2	CEWX6.3V-100M
C2601	356722209R2	CEWX6.3V-22M
C2602	356721019R2	CEWX6.3V-100M
C2901	356721019R2	CEWX6.3V-100M
C2902	356721019R2	CEWX6.3V-100M
C2903	356721019R2	CEWX6.3V-100M
C2904	356721019R2	CEWX6.3V-100M
C2905	356721019R2	CEWX6.3V-100M
C2907	3567A2219R2	CEWX4V-220M
C2906	356721019R2	CEWX6.3V-100M

Coils

L1001	231237K470R2	NCH-1479
L1002	231237K470R2	NCH-1479
L1201	231237M022R2	NCH-1471
L1202	231237M022R2	NCH-1471
L1203	231237M022R2	NCH-1471
L1204	231237M022R2	NCH-1471
L1251	231237M022R2	NCH-1471
L2001	231237M022R2	NCH-1471
L2002	231237M022R2	NCH-1471
L2301	231237M022R2	NCH-1471
L2302	231237M022R2	NCH-1471
L2401	231237M022R2	NCH-1471
L2404	231237M022R2	NCH-1471
L2601	230949R2	BLM21P221SG
L2602	230949R2	BLM21P221SG
L2901	231237M022R2	NCH-1471
L2902	231237M022R2	NCH-1471
L2903	231237M022R2	NCH-1471
L2904	231237M022R2	NCH-1471

Sockets

P1001	2101-1414-0	NSCT-26P2671	25052775R2
P2001B	2101-1413-0	NSCT-14P2684	25052788R2
P2401B	2101-1412-0	NSCT-15P2685	25052789R2

Plugs

P1101	25055979R2	NPLG-6P932
P2501A	25055980R2	NPLG-7P933
P2901A	25055979R2	NPLG-6P932

Resistors

R1117	435031032R1	RN72K1J-103FE	(DISC judging is slow.)
R1118	435031032R1	RN72K1J-103FE	5% to 1% Error (#5601)
R2416	435031522R1	RN72K1J-152FE	5% to 1% Error (#5601)
R2418	435032712R1	RN72K1J-271FE	
R2419	435031522R1	RN72K1J-152FE	
R2421	435032712R1	RN72K1J-271FE	
R2422	435031522R1	RN72K1J-152FE	
R2424	435032712R1	RN72K1J-271FE	
R2425	435031522R1	RN72K1J-152FE	
R2427	435032712R1	RN72K1J-271FE	
R2428	435031522R1	RN72K1J-152FE	

C-R Network

R1001	43474415204R1	RM4KJ152X04
R1002	43474400004R1	RM4KJ000X04
R1205	43474410104R1	RM4KJ101X04
R1206	43474410104R1	RM4KJ101X04
R1208	43474410104R1	RM4KJ101X04
R1209	43474433004R1	RM4KJ330X04
R1210	43474410104R1	RM4KJ101X04
R1211	43474410104R1	RM4KJ101X04
R1212	43474418104R1	RM4KJ181X04
R1213	43474410304R1	RM4KJ103X04
R1234	43474410104R1	RM4KJ101X04
R1235	43474410104R1	RM4KJ101X04
R1236	43474410104R1	RM4KJ101X04

R1237	43474410104R1	RM4KJ101X04	
R1238	43474410104R1	RM4KJ101X04	
R1241	43474410104R1	RM4KJ101X04	
R1251	43474410104R1	RM4KJ101X04	
R1252	43474410104R1	RM4KJ101X04	
R1253	43474410104R1	RM4KJ101X04	
R1254	43474410104R1	RM4KJ101X04	
R1291	8911-0020-0	RM6KJ103X08	43474610308R1
R1292	8911-0020-0	RM6KJ103X08	43474610308R1
R1293	8911-0020-0	RM6KJ103X08	43474610308R1
R2022	43474447004R1	RM4KJ470X04	
R2023	43474447004R1	RM4KJ470X04	
R2025	43474447004R1	RM4KJ470X04	
R2035	43474447004R1	RM4KJ470X04	
R2038	43474415004R1	RM4KJ150X04	
R2039	43474415004R1	RM4KJ150X04	
R2040	43474415004R1	RM4KJ150X04	
R2041	43474415004R1	RM4KJ150X04	
R2042	43474415004R1	RM4KJ150X04	
	Resonator		
X2601	3010353R2	FCX-03-27MHz	

U2: DISPLAY CIRCUIT PC BOARD (NADIS-7808-1A/-1B)

CIRCUIT NO.	PART NO.	DESCRIPTION	REMARK
	IC		
Q801	22241814R3	MPD780232GC-070-8BT	
	Transistors		
Q805	2216470R2	DTC114YKA	
Q805 or	2216260R2	RN1407	
Q805 or	2216340R2	KRC107S	
Q806	2213145R2	2SC2712-GR	
	FL Tube		
Q802	2460-2020-0	HNV-12SM34	212236
	Remote sensor		
Q808	481M-7138-3	RPM7138	241346
	Resonator		
X801	3010343	CSTS0500MG06	
	Plugs		
P704	2101-1417-0	NPLG-11P949	25055997
P804A	25055443	NPLG-5P425	
P805A	25055442	NPLG-4P424	
	Capacitors		
C801	394641007	CE04W16V10M(VR)	
C804	394621017	CE04W6.3V100M(VR)	
C820	394680227	CE04W50V2.2M(VR)	
	FL Holder		
Q802A	4154-6111-0		27191195
	Resistor		
R846	4717-4R7J-1	RS1/2WBJ-4.7	443520474M
	Tapping screw		
Q802B	838430068	3TTB+6B(BC)	

U3: MECHANISM CONTROL CIRCUIT PC BOARD (NADG-7809)

CIRCUIT NO.	PART NO.	DESCRIPTION	REMARK
	ICs		
Q701	3132-0190-1	MPD780053GC-141-8BT	22241966R3
Q702	3132-0200-0	S-80130CLMC-JIP-T2	22241924R2
Q704	22240239	TA7291S	
Q705	22240239	TA7291S	
	Transistors		
Q703	2216480R2	DTA114YKA	
Q703 or	2216360R2	RN2407	
Q703 or	2216350R2	KRA107S	
Q706	2216470R2	DTC114YKA	
Q706 or	2216260R2	RN1407	
Q706 or	2216340R2	KRC107S	

Q707	2214373R2	2SA1162-O	
Q708 or	2216260R2	RN1407	
Q708 or	2216340R2	KRC107S	
Q709	2216470R2	DTC114YKA	
Q709 or	2216260R2	RN1407	
Q709 or	2216340R2	KRC107S	
Q710	2213145R2	2SC2712-GR	
Q711	2213145R2	2SC2712-GR	
Q712	2216470R2	DTC114YKA	
Q712 or	2216260R2	RN1407	
Q712 or	2216340R2	KRC107S	
Q713	2211705	2SD655-E	
Q714	2211705	2SD655-E	
Q715	2216480R2	DTA114YKA	
Q715 or	2216360R2	RN2407	
Q715 or	2216350R2	KRA107S	
Diodes			
D701	224490270R2	UDZ2.7B, Zener	
D702	224490220R2	UDZ2.2B, Zener	
D703	224550430R2	UDZS4.3B, Zener	
D731	223269R2	1SS355	
D731 or	223234R2	1SS352	
D732	224550510R2	UDZS5.1B, Zener	
D733	223269R2	1SS355	
D733 or	223234R2	1SS352	
D734	223269R2	1SS355	
D734 or	223234R2	1SS352	
Coils			
L701	1803-0075-0	NCH-3608K470, Choke	231333K470
L702	1803-0075-0	NCH-3608K470, Choke	231333K470
Plugs			
P2501B	25055371	NPLG-7P354	
P2901B	25055370	NPLG-6P353	
P708A	2101-1451-0	NPLG-2P940	25055988
Socket AS			
P701A	7012-6540-0	NSAS-6P1140	2002A290625UL
P704A	7012-6542-0	NSAS-22P1126	2002E242215UL
P710A	7012-6550-0	NSAS-30P1102	2004C193060UL
Sockets			
P707A	25052202	NSCT-6P2099	
P707Aor	25051813	NSCT-6P1600	
P707Aor	2101-1421-0	NSCT-6P1802	25052015
Push switches			
S701	5200-4862-0-01	NPS-111-S679	25035716
S702	5200-4862-0-01	NPS-111-S679	25035716
S703	5200-4862-0-01	NPS-111-S679	25035716
Electric capacitors			
C703	355741017	CE04W16V100M(5L)	
C704	355741017	CE04W16V100M(5L)	
C711	355741007	CE04W16V10M(5L)	
C713	355741007	CE04W16V10M(5L)	
C715	355741007	CE04W16V10M(5L)	
C717	355741007	CE04W16V10M(5L)	
C719	355741007	CE04W16V10M(5L)	
C721	355741007	CE04W16V10M(5L)	
C729	355721017	CE04W6.3V100M(5L)	
C731	355780107	CE04W50V1M(5L)	
C767	355741017	CE04W16V100M(5L)	
C768	355721017	CE04W6.3V100M(5L)	
Resistors			
R709	415470474	R25J-4.7	
R715	415470474	R25J-4.7	
Resonator			
X701	2703-0870-0	CSTLS4M50G56-A0	3010379

CIRCUIT NO.	PART NO.	DESCRIPTION	REMARK
	ICs		
Q201	22241767R2	LA73054	
Q411	22274004HR2TO	TC74VHCU04FT	
	Transistors		
Q202	2216470R2	DTC114YKA	
Q202 or	2216260R2	RN1407	
Q202 or	2216340R2	KRC107S	
Q203	2216480R2	DTA114YKA	
Q203 or	2216360R2	RN2407	
Q203 or	2216350R2	KRA107S	
	Coils		
L201	230958R1	BK1608LM182-T, EMI Filter	
L202	230958R1	BK1608LM182-T, EMI Filter	
L203	230958R1	BK1608LM182-T, EMI Filter	
L204	230958R1	BK1608LM182-T, EMI Filter	
L205	230958R1	BK1608LM182-T, EMI Filter	
L206	230958R1	BK1608LM182-T, EMI Filter	
L221	231237K221R2	NCH-1482, EMI Filter	
L404	231237M022R2	NCH-1471, Choke	
L405	230958R1	BK1608LM182-T, EMI Filter	
	Pin jacks		
P201	2113-2017-0	NPJ-3PDGLR511	25045721
P202A	25045656	NPJ-5PDBY456	
P402	25045548	NPJ-1PDOR369	
	Socket AS		
P403A	7012-6551-0	NSAS-4P1100	2009990769UL
	Sockets		
P2401A	25052352	NSCT-15P2433	25052536
P2401A or	2101-1441-0	NSCT-15P2249	
	Plugs		
P701B	25055989	NPLG-3P941	
	Electric capacitors		
C203	394641007	CE04W16V10M(VR)	
C205	394641007	CE04W16V10M(VR)	
C207	394641007	CE04W16V10M(VR)	
C209	394641007	CE04W16V10M(VR)	
C210	394621017	CE04W6.3V100M(VR)	
C211	394621017	CE04W6.3V100M(VR)	
C212	394621027	CE04W6.3V1000M(VR)	
C213	394624717	CE04W6.3V470M(VR)	
C214	394621027	CE04W6.3V1000M(VR)	
C215	394624717	CE04W6.3V470M(VR)	
C216	394624717	CE04W6.3V470M(VR)	
	Photo coupler		
Q412	24120094	TOTX179	
	Clip		
E201	260224	CP-1S	

U5: AUDIO SIGNAL OUTPUT TERMINAL PC BOARD (NAAF-7811)

CIRCUIT NO.	PART NO.	DESCRIPTION	REMARK
	ICs		
Q401	22241776R2	PCM1742KE	
Q403	22241448R2	NJM4580M-D	
Q404	22241448R2	NJM4580M-D	
Q405	22241448R2	NJM4580M-D	
Q406	22241448R2	NJM4580M-D	
Q413	22241289R2	NJM2370U05	
	Transistors		
Q109	2216480R2	DTA114YKA	
Q109 or	2216360R2	RN2407	
Q109 or	2216350R2	KRA107S	
Q110	2216470R2	DTC114YKA	
Q110 or	2216260R2	RN1407	
Q110 or	2216340R2	KRC107S	
Q407	2216141R2	HN1C03F-B	

Q408	2216141R2	HN1C03F-B
	Coils	
L403	231237M022R2	NCH-1471, Choke
L406	231237M022R2	NCH-1471, Choke
L407	230958R1	BK1608LM182-T, EMI Filter
	Diodes	
D101	223269R2	1SS355
D101 or	223234R2	1SS352
D102	223269R2	1SS355
D102 or	223234R2	1SS352
D103	223269R2	1SS355
D103 or	223234R2	1SS352
D104	223269R2	1SS355
D104 or	223234R2	1SS352
D401	223269R2	1SS355
D401 or	223234R2	1SS352
	Electric capacitors	
C401	394641017	CE04W16V100M(VR)
C402	394641017	CE04W16V100M(VR)
C405	394622217	CE04W6.3V220M(VR)
C406	394622217	CE04W6.3V220M(VR)
C409	394680477	CE04W50V4.7M(VR)
C411	394642207	CE06W16V22M(VR)
C412	394642207	CE06W16V22M(VR)
C419	394682207	CE04W50V22M(VR)
C420	394682207	CE04W50V22M(VR)
C421	394644717	CE04W16V470M(VR)
C422	394644717	CE04W16V470M(VR)
C423	394680107	CE04W50V1.0M(VR)
C425	394622217	CE04W6.3V220M(VR)
C432	394621017	CE04W6.3V100M(VR)
C434	394641007	CE04W16V10M(VR)
C435	394641007	CE04W16V10M(VR)
C441	394644707	CE04W16V47M(VR)
C442	394680107	CE04W50V1.0M(VR)
	Capacitors	
C407	374721044	ECQ-V50V-104J, TF
C408	374721044	ECQ-V50V-104J, TF
C410	374721044	ECQ-V50V-104J, TF
C413	374722215	ECQ-B50V-221K, TF
C414	374722215	ECQ-B50V-221K, TF
C415	374721224	ECQ-B50V-122J, TF
C416	374721224	ECQ-B50V-122J, TF
C417	374722724	ECQ-B50V-272J, TF
C418	374722724	ECQ-B50V-272J, TF
C439	374721024	ECQ-B50V-102J, TF
C440	374721024	ECQ-B50V-102J, TF
	Sockets	
P2001A	25052508	NSCT-14P2405
P2001Aor	25052314	NSCT-14P2211
	Pin jacks	
P401	25045628	NPJ-2PDRW435, Audio out
P602	25045589	NPJ-2PDB400, RI
	Plugs	
P403	25055132	NPLG-2P116
P702	25055449	NPLG-11P431
P702B	25055449	NPLG-11P431
	Resistors	
R455	443521514	RS1/2WBJ-150, Oxide metal
R456	443521514	RS1/2WBJ-150, Oxide metal
R471	443521014	RS1/2WBJ-100, Oxide metal

U6: DISC SELECT SWITCH PC BOARD (NASW-7812)

CIRCUIT NO.	PART NO.	DESCRIPTION	REMARK
	Socket AS		
P802A	7012-6546-0	NSAS-8P1118	200EE390805UL

P806A	7012-6549-0	NSAS-6P1137	200EE340615UL
	Push switch		
S801	25035718	NPS-111-S681	
S802	25035718	NPS-111-S681	
S803	25035718	NPS-111-S681	
S804	25035718	NPS-111-S681	
S805	25035718	NPS-111-S681	
S806	25035718	NPS-111-S681	
S807	25035718	NPS-111-S681	
S808	25035718	NPS-111-S681	

U7: KEY OPERATION SWITCH PC BOARD (NASW-7813)

CIRCUIT NO.	PART NO.	DESCRIPTION	REMARK
	Socket AS		
P804B	7012-6547-0	NSAS-10P1119	2002E341005UL
	Push switches		
S809	25035718	NPS-111-S681	
S810	25035718	NPS-111-S681	
S811	25035718	NPS-111-S681	
S812	25035718	NPS-111-S681	
S813	25035718	NPS-111-S681	
S814	25035718	NPS-111-S681	

U8: STANDBY SWITCH PC BOARD (NASW-7814)

CIRCUIT NO.	PART NO.	DESCRIPTION	REMARK
	Diode		
D803	225321	SLR-342VR, LED Standby	
	Socket AS		
P805B	7012-6548-0	NSAS-8P1120	2002E390805UL
	Push switches		
S815	25035718	NPS-111-S681	
S816	25035718	NPS-111-S681	
S817	25035718	NPS-111-S681	
S818	25035718	NPS-111-S681	
S819	25035718	NPS-111-S681	

U9: LED DISPLAY PC BOARD (NADIS-7815)

CIRCUIT NO.	PART NO.	DESCRIPTION	REMARK
	Transistors		
Q809	2216470R2	DTC114YKA	
Q809 or	2216260R2	RN1407	
Q809 or	2216340R2	KRC107S	
Q810	2216470R2	DTC114YKA	
Q810 or	2216260R2	RN1407	
Q810 or	2216340R2	KRC107S	
	Diodes		
D801	3700-2824-B	SLR-343BBT, LED Green	225419
D802	3700-2824-B	SLR-343BBT, LED Orange	225419
	Holders		
D801A	27191190	(LED)LA-5-6	
D802A	27191190	(LED)LA-5-6	

U10: ROULETTE MOTOR PC BOARD (NAETC-7816)

CIRCUIT NO.	PART NO.	DESCRIPTION	REMARK
	Plug		
P709A	25055440	NPLG-2P422	

U11: LOADING MOTOR PC BOARD (NAETC-7817)

CIRCUIT NO.	PART NO.	DESCRIPTION	REMARK
	Socket AS		
P708B	2002A340420UL	NSAS-4P1138	

U12: DISC SENSOR PC BOARD (NAETC-7818)

CIRCUIT NO.	PART NO.	DESCRIPTION	REMARK
	Socket AS		
P709B	7012-6545-0	NSAS-4P1127	2002E390415UL

	Sockets	
P707B	25052239	NSCT-6P2136
P707Bor	25052052	NSCT-6P1839
P707Bor	25051850	NSCT-6P1637

	Photo interrupter	
Q716	24190046	GP2S28, Disc sensor

	Photo coupler		
Q717	481P-1576-3	RPI-576, Disc stop sens.	24120107

IC BLOCK DIAGRAM/ TERMINAL DESCRIPTION

Q403,Q404,Q405,Q406 NJM4580M-D (2-ch Ope. amp.)

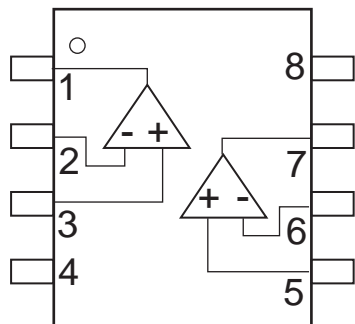

(Top view)

Pin description

1. A OUTPUT
2. A -INPUT
3. A +INPUT
4. V-
5. B +INPUT
6. B -INPUT
7. B OUTPUT
8. V+

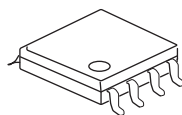

IC BLOCK DIAGRAM/ TERMINAL DESCRIPTION

Q2401: NJM2373AF (Adjustable High Precision Shunt Regulator)

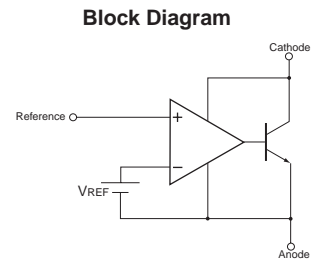
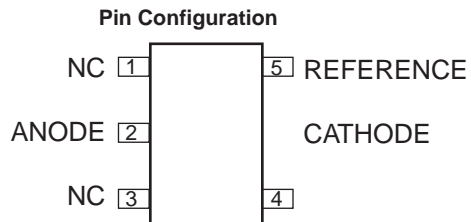

IC BLOCK DIAGRAM/ TERMINAL DESCRIPTION

Q431: NJM2370 (Regulated power supply)

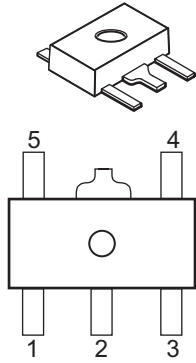

PIN DESCRIPTION
 1. Control
 2. GND
 3. Noise Bypass
 4. Vout
 5. Vin

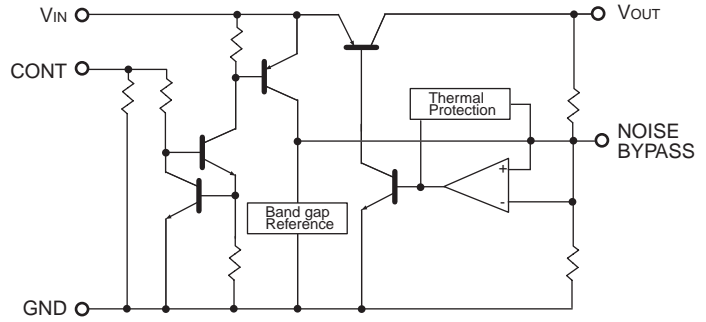

IC BLOCK DIAGRAM/ TERMINAL DESCRIPTION

Q1002: NJM2115V (2-ch Ope. amp.)

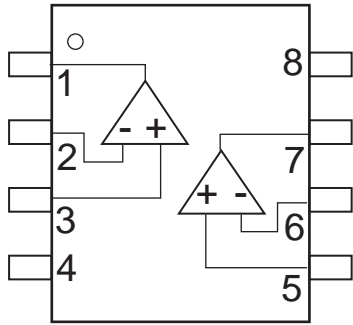

(Top view)

Pin description

1. A OUTPUT
2. A -INPUT
3. A +INPUT
4. V-
5. B +INPUT
6. B -INPUT
7. B OUTPUT
8. V+

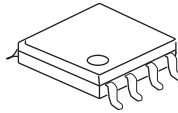

IC BLOCK DIAGRAM/ TERMINAL DESCRIPTION

Q201 : LA73054 6-CHANNEL VIDEO DRIVER

Block Diagram

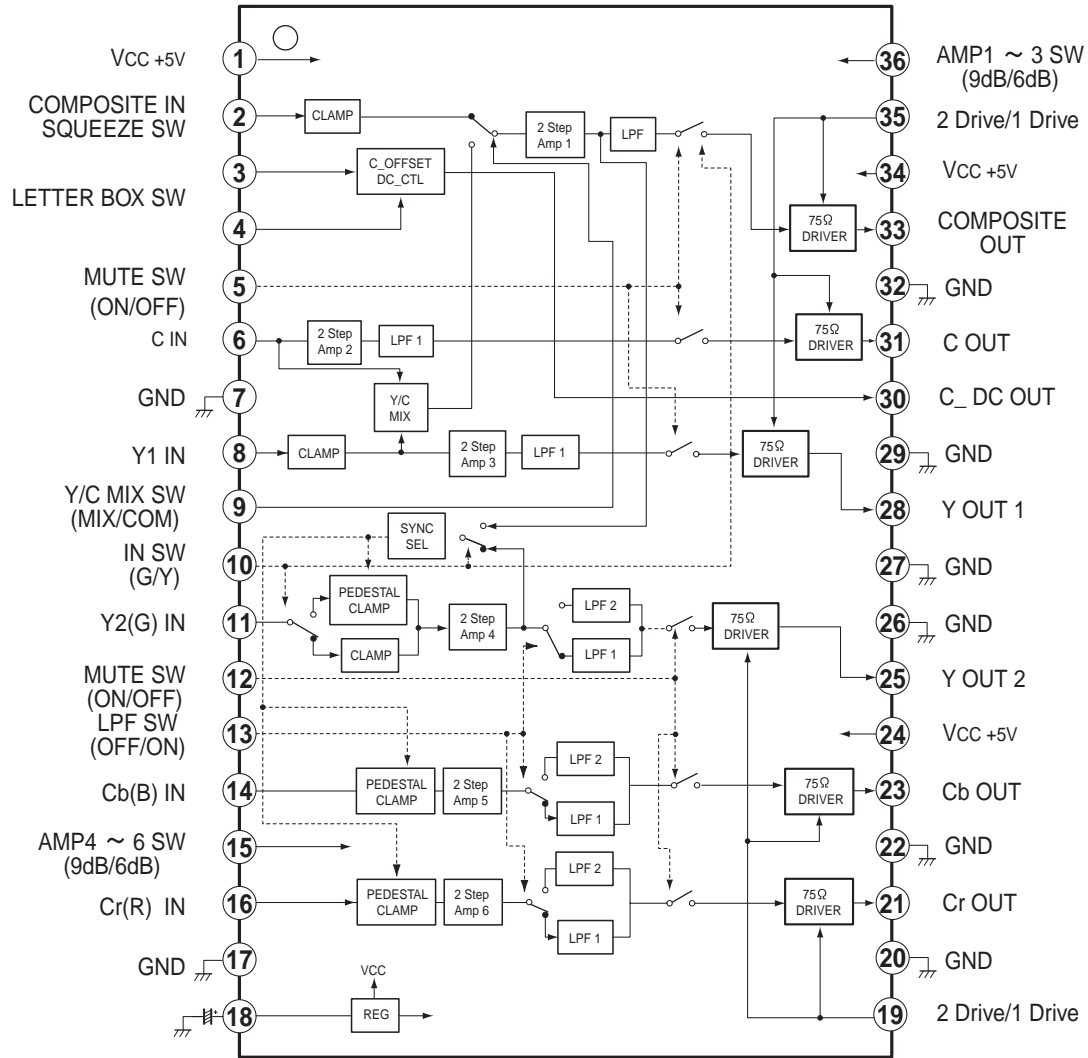

IC BLOCK DIAGRAM/ TERMINAL DESCRIPTION

Q2003 : IS24C08-3Z EEPROM

(8K-Bit 2-Wire Serial CMOS EEPROM)

PIN CONFIGURATION

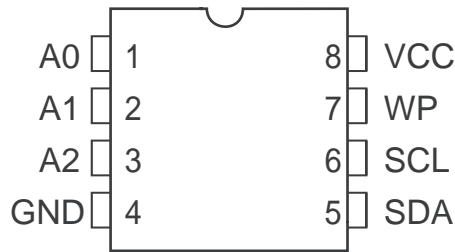

PIN DESCRIPTIONS

A0-A2	Address Inputs
SDA	Serial Address/Data I/O
SCL	Serial Clock Input
WP	Write Protect Input
Vcc	Power Supply
GND	Ground

SCL

This input clock pin is used to synchronize the data transfer to and from the device.

SDA

The SDA is a Bi-directional pin used to transfer addresses and data into and out of the device. The SDA pin is an open drain output and can be wire-Or'ed with other open drain or open collector outputs. The SDA bus requires a pullup resistor to Vcc.

A0, A1, A2

The A0, A1 and A2 are the device address inputs. The IS24C08 only use A2 input for hardwire addressing and a total of two devices may be addressed on a single bus system. The A0 and A1 pins are not used by IS24C08. They may be left floating or tied to either GND or Vcc.

WP

WP is the Write Protect pin. On the and 24C08, if the WP pin is tied to Vcc the entire array becomes Write Protected (Read only). On the 24C16, if the WP pin is tied to Vcc the upper half array becomes Write Protected (Read only). When WP is tied to GND or left floating normal read/write operations are allowed to the device.

FUNCTIONAL BLOCK DIAGRAM

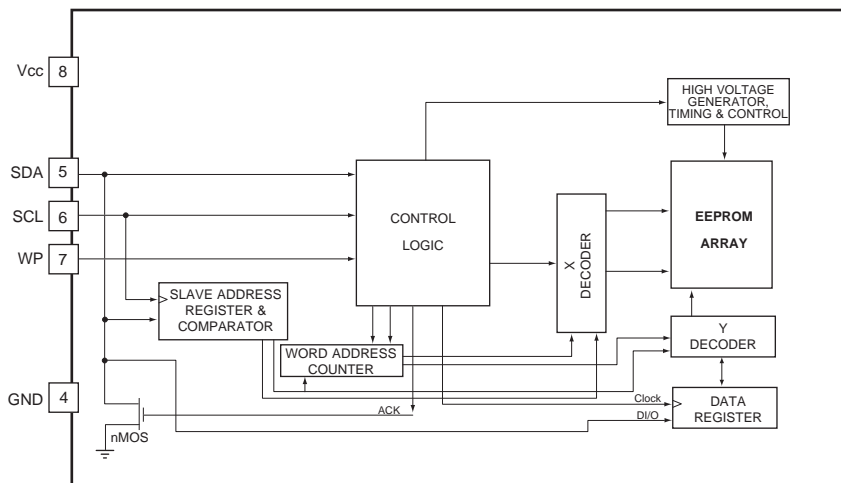

IC BLOCK DIAGRAM/ TERMINAL DESCRIPTION

Q2303 : IC42S16400-7T SYNCHRONOUS DYNAMIC RAM

The IC42S16400 are high-speed 67, 108, 864-bit synchronous dynamic random-access memories, organized as 2,097, 152 x 8 x 4 and 1,48, 576 x 16 x 4 (word x bit x bank), respectively. The synchronous DRAMs achieved high-speed data transfer using the pipeline architecture and clock frequency up to 133MHz for -7.

All input and outputs are synchronized with the positive edge of the clock. The synchronous DRAMs are compatible with Low Voltage TTL.

PIN CONFIGURATIONS

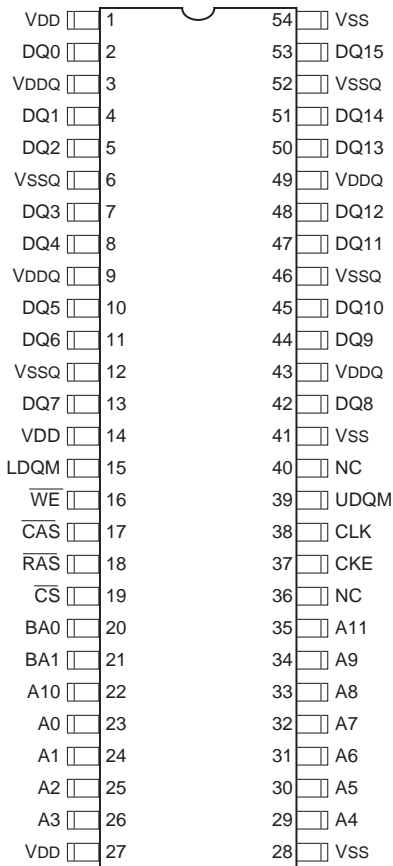

PIN DESCRIPTIONS

CLK	Master Clock	DQM	DQ Mask Enable
CKE	Clock Enable	A0 - 11	Address Input
CS	Chip Select	BA0, 1	Bank Address
RAS	Row Address Strobe	VDD	Power Supply
CAS	Column Address Strobe	VDDQ	Power Supply for DQ
WE	Write Enable	VSS	Ground
DQ0 - DQ15	Data I/O	VSSQ	Ground for DQ

BLOCK DIAGRAM

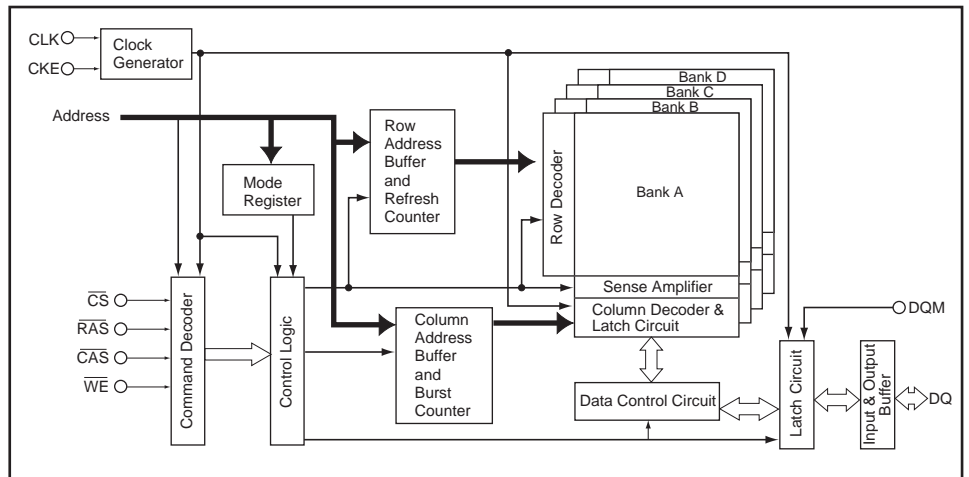

IC BLOCK DIAGRAM/ TERMINAL DESCRIPTION

Q1251: IC41LV16100-50T 16-MBIT DYNAMIC RAM

PIN CONFIGURATION

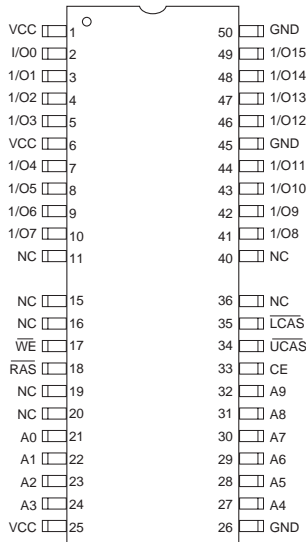

PIN DESCRIPTION

- A0-A9 Address input
- I/O0-15 Data inputs/outputs
- WE Write enable
- OE Output enable
- RAS Row address strobe
- UCAS Upper column address strobe
- LCAS Lower column address strobe
- VCC Power
- GND Ground
- NC No connection

FUNCTIONAL BLOCK DIAGRAM

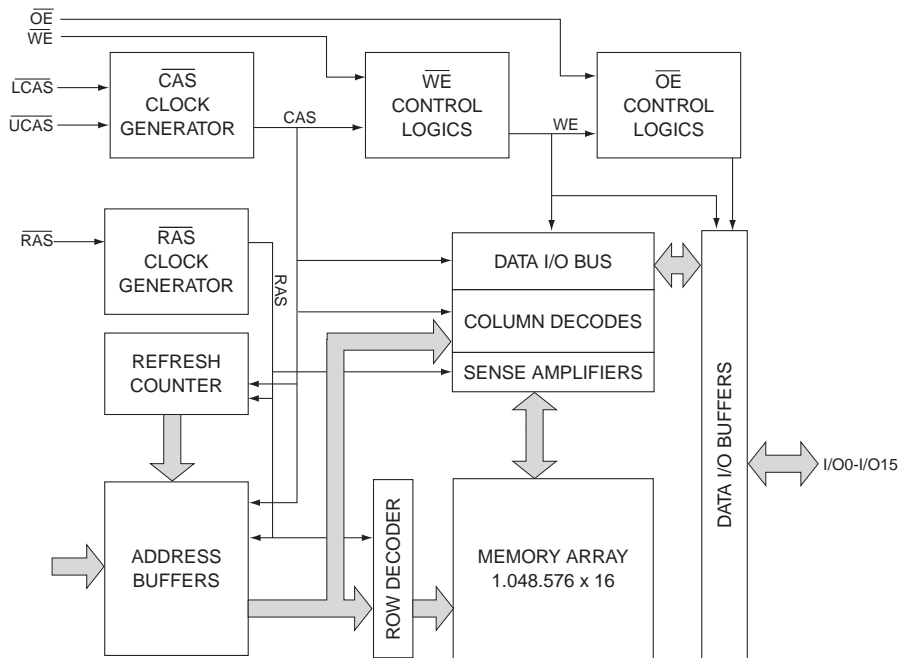

TRUTH TABLE

Function	RAS	LCAS	UCAS	WE	OE	Address tr/tc	I/O	
Standby	H	H	H	X	X	X	High-Z	
Read: Word	L	L	L	H	L	ROW/COL	Dout	
Read: Lower Byte	L	L	H	H	L	ROW/COL	Lower Byte. Dout Upper Byte, High-Z	
Read: Upper Byte	L	H	L	H	L	ROW/COL	Lower Byte, High-Z Upper Byte. Dout	
Write: Word (Early Write)	L	L	L	L	X	ROW/COL	Din	
Write: Lower Byte (Early Write)	L	L	H	L	X	ROW/COL	Lower Byte. Din Upper Byte, High-Z	
Write: Upper Byte (Early Write)	L	H	L	L	X	ROW/COL	Lower Byte, High-Z Upper Byte. Din	
Read Write	L	L	L	H-L	H-L	ROW/COL	Dout, Din	
EDO Page-Mode Read	1st Cycle	L	H-L	H-L	H	L	ROW/COL	Dout
	2nd Cycle	L	H-L	H-L	H	L	NA/COL	Dout
	Any Cycle	L	L-H	L-H	H	L	NA/NA	Dout
EDO Page-Mode Read	1st Cycle	L	H-L	H-L	L	X	ROW/COL	Din
	2nd Cycle	L	H-L	H-L	L	X	NA/COL	Din
EDO Page-Mode Read-Write	1st Cycle	L	H-L	H-L	H-L	L	ROW/COL	Dout, Din
	2nd Cycle	L	H-L	H-L	H-L	L-H	NA/COL	Dout, Din
Hidden Refresh	1st Cycle	L-H-L	L	L	-H	L	ROW/COL	Dout
	2nd Cycle	L-H-L	L	L	L	X	ROW/COL	Dout
RAS-Only Refresh	L	H	H	X	X	ROW/NA	High-Z	
CBR Refresh	H-L	L	L	X	X	X	High-Z	

IC BLOCK DIAGRAM/ TERMINAL DESCRIPTION

Q2901, Q2904 : uPC29M33T REGURATOR IC 3.3 V output

Q2902, Q2903 : uPC2918T REGURATOR IC 1.8 V output

BLOCK DIAGRAM

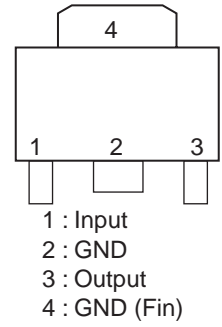
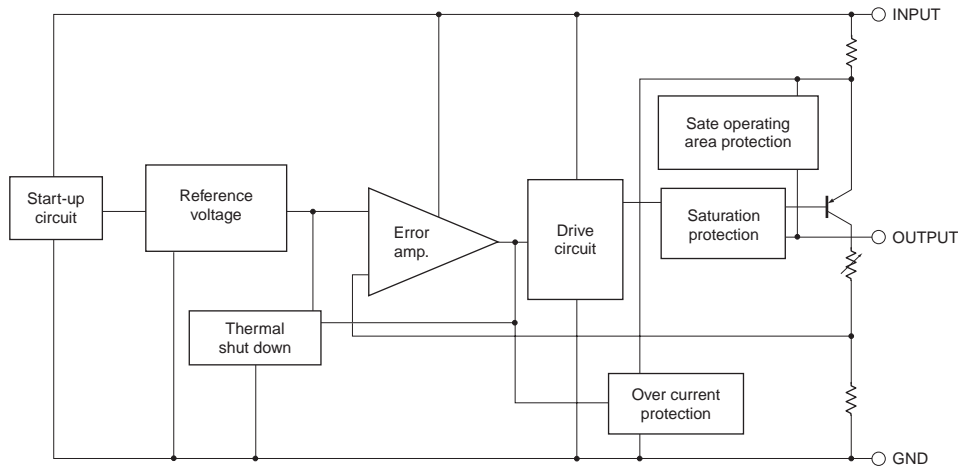

MICROPROCESSOR TERMINAL DESCRIPTION

PIN LAYOUT

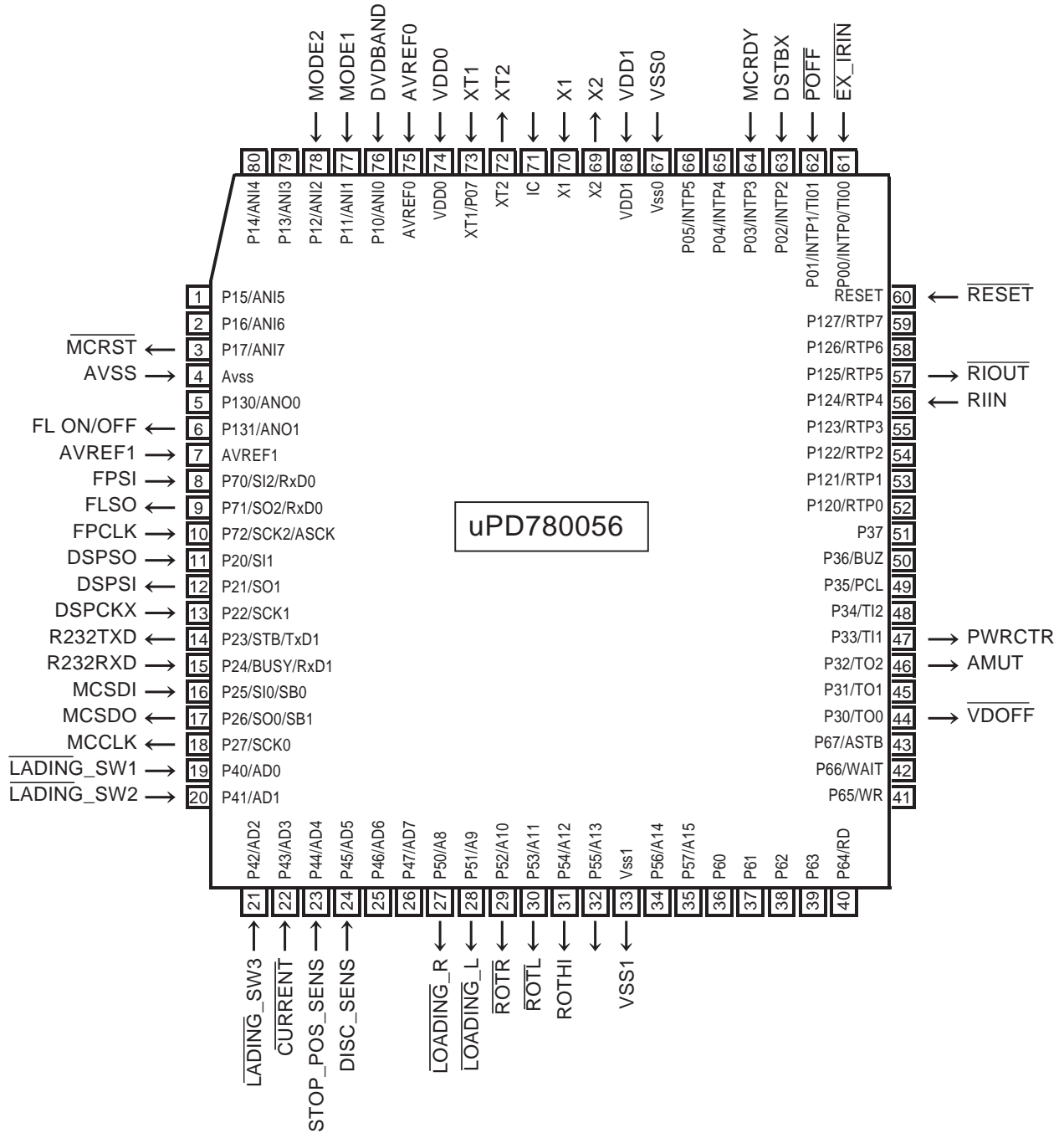

MICROPROCESSOR TERMINAL DESCRIPTION-1

PIN NO.	Sign	Functional name	I/O	Description
1	P15/ANI5			
2	P16/ANI6			
3	P17/ANI7	$\overline{\text{MCRST}}$	O	Reset output pin for sub microprocessor.
4	Avss	AVSS	I	To connect VSS.
5	P130/ANO0			
6	P131/ANO1	FL ON/OFF	O	Power ON/ OFF pin of FL tube.
7	AVREF1	AVREF1	I	Reference voltage input pin for D/A converter.
8	P70/SI2/RxD0	FPSI	I	Serial data input pin for Flash processor.
9	P71/SO2/RxD0	FLSO	O	Serial data output pin for Flash processor.
10	P72/SCK2/ASCK	FPCLK	I	Serial clock input pin for Flash processor.
11	P20/SI1	DSPSO	I	Serial communication port (SO).
12	P21/SO1	DSPSI	O	Serial communication port (SI).
13	P22/SCK1	DSPCKX	I	Serial communication port (CLK).
14	P23/STB/TxD1	R232TXD	O	TXD output pin. Serial data output pin at re-writing of the flash data.
15	P24/BUSY/RxD1	R232RXD	I	RXD input pin. Serial data input pin at re-writing of the flash data.
16	P25/SI0/SB0	MCSDI	I	Data input pin of sub microprocessor.
17	P26/SO0/SB1	MCSDO	O	Data output pin of sub microprocessor.
18	P27/SCK0	MCCLK	O	Serial clock output data pin.
19	P40/AD0	$\overline{\text{LADING_SW1}}$	I	Detecting pin of loading switch-1.
20	P41/AD1	$\overline{\text{LADING_SW2}}$	I	Detecting pin of loading switch-2.
21	P42/AD2	LADING_SW3	I	Detecting pin of loading switch-3.
22	P43/AD3	CURRENT	I	Detecting current pin of loading (tray) motor.
23	P44/AD4	STOP_POS_SENS	I	The input terminal of the detection sensor of a roulette stop position.
24	P45/AD5	DISC_SENS	I	Disk detection sensor input terminal.
25	P46/AD6			
26	P47/AD7			
27	P50/A8	$\overline{\text{LOADING_R}}$	O	Loading tray motor control terminal. L= right-handed rotation
28	P51/A9	$\overline{\text{LOADING_L}}$	O	Loading tray motor control terminal. L= left-handed rotation
29	P52/A10	$\overline{\text{ROTR}}$	O	Roulette motor control terminal. L= clockwise rotation.
30	P53/A11	$\overline{\text{ROTL}}$	O	Roulette motor control terminal. L= counterclockwise rotation.
31	P54/A12	ROTHI	O	Roulette motor speed control terminal.
32	P55/A13		O	
33	Vss1	VSS1	O	To connect to GND.
34	P56/A14			
35	P57/A15			
36	P60			Not used. To connect to GND
37	P61			Not used. To connect to GND
38	P62			Not used. To connect to GND
39	P63			Not used. To connect to GND

MICROPROCESSOR TERMINAL DESCRIPTION-2

PIN NO.	Sign	Functional name	I/O	Description
40	P64/RD			Not used. To connect to GND
41	P65/WR			Not used. To connect to GND
42	P66/WAIT			Not used. To connect to GND
43	P67/ASTB			Not used. To connect to GND
44	P30/TO0	$\overline{\text{VDOFF}}$	O	Video off signal output pin.
45	P31/TO1			
46	P32/TO2	AMUT	O	Analog mute signal output pin.
47	P33/TI1	PWRCTR	O	Power control output pin. When power ON is "H".
48	P34/TI2			Not used. To connect to GND
49	P35/PCL			Not used. To connect to GND
50	P36/BUZ			Not used. To connect to GND
51	P37			Not used. To connect to GND
52	P120/RTP0			Not used. To connect to GND
53	P121/RTP1			Not used. To connect to GND
54	P122/RTP2			Not used. To connect to GND
55	P123/RTP3			Not used. To connect to GND
56	P124/RTP4	RIIN	I	RI system code data input pin.
57	P125/RTP5	RIOUT	O	RI system code data output pin.
58	P126/RTP6			Not used. To connect to GND
59	P127/RTP7			Not used. To connect to GND
60	RESET	$\overline{\text{RESET}}$	I	Reset pin of microprocessor.
61	P00/INTP0/TI00	$\overline{\text{EX_IRIN}}$	I	Remote control signal input pin from multi room.
62	P01/INTP1/TI01	POFF	I	Power failure detection pin.
63	P02/INTP2	DSTBX	I	Serial data output pin (main STB signal).
64	P03/INTP3	MCRDY	I	Ready data detecting input pin of sub microprocessor.
65	P04/INTP4			Not used. To connect to GND
66	P05/INTP5			Not used. To connect to GND
67	Vss0	VSS0	I	To connect to GND
68	VDD1	VDD1	I	To connect to GND
69	X2	X2	O	The crystal (5MHz) connection terminal for a main system clock oscillation.
70	X1	X1	I	The crystal (5MHz) connection terminal for a main system clock oscillation.
71	IC		I	To connect to GND. Internal connection pin.
72	XT2	XT2	O	Not used. Use to clock oscillator connection for sub microprocessor.
73	XT1/P07	XT1	I	Not used. To connect to VDD
74	VDD0	VDD0	I	To connect to +5V (power supply).
75	AVREF0	AVREF0	I	The reference voltage input pin of a A/D converter.
76	P10/ANI0	DVDBAND	I	The destination judging terminal for DVD.
77	P11/ANI1	MODE1	I	Mode select input pin 1.
78	P12/ANI2	MODE2	I	Mode select input pin 2.
79	P13/ANI3			Not used. To connect to GND
80	P14/ANI4			Not used. To connect to GND

PART REPLACEMENT-1

1. CABINET REPLACEMENT

1-1. Top cover and front panel

1-1-1. Remove the top cover. (six screws)

1-1-2. Remove the front panel assy. Remove the FFC (P704) and three screws.



1-2. Camper stay and Roulette

1-2-1. Remove the three screws and clamber assy. (1)

1-2-2. Remove one screw and roulette. (2)



(1)

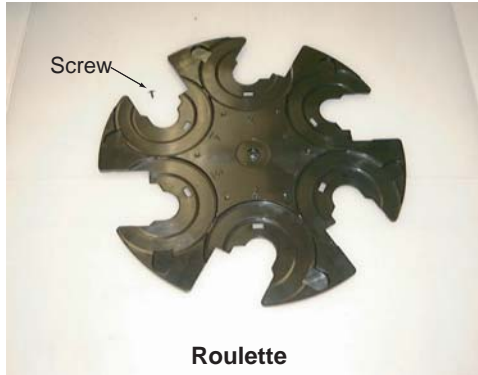

Roulette

(2)



1-3. Tray panel and Mechanism assy

<Mechanism assy>

1-3-1. Remove four screws. (1)

1-3-2. Remove the mechanism assy.

1-3-3. Remove the FFC. (2)



(1)

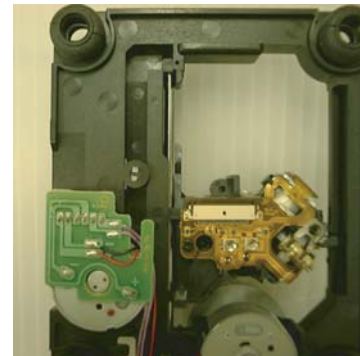

(2)

Slide a holder direction the allow and remove the FFC.

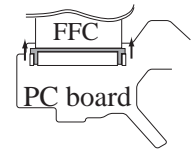

Bottom side of mechanism

<Tray panel>

Removal

1-4-1. Slide the slider on the bottom chassis. (1)

1-4-2. Eject the tray panel.

1-4-3. Remove one FFC (P707) and draw out the tray while pulling a nail. (2)

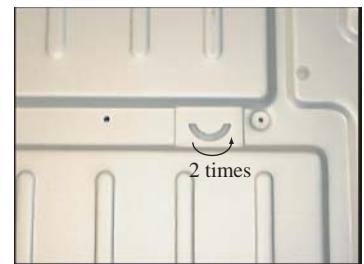

(1)

Bottom side view

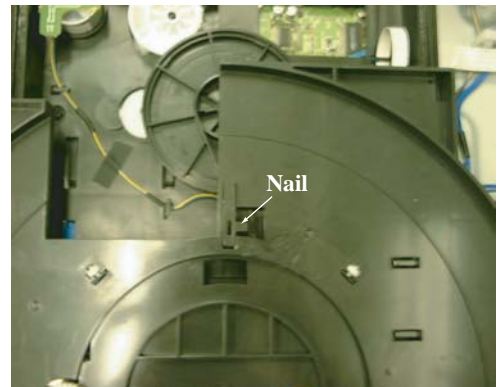

(2)

PART REPLACEMENT-2



Tray panel <Mounting>

- 1-4-4. Insert the tray panel.
- 1-4-5. Set the FFC (P707) to mechanism control PC board assy.
- 1-4-6. The pin of main gear and fitting the position of the slot on the tray.



- 1-4-7. Pull up the nail on the tray panel and insert the tray.



UPGRADE THE FIRMWARE/ TEST MODES

1 Updating the Firm Ware

- 1-1 Open the DISC tray and set the Firm Ware Recorded DISC on DISC1 bay.
- 1-2 Close the DISC tray.
 - Will start the Firm Ware updating automatically.
 - Will tray open after finish the updating.
- 1-3 Take out the disc.

2 Test mode

- 2-1 Press the "**STOP**" & "**DISPLAY**" at the same with NO DISC condition.
Current version number of sub-micon is displayed on the FL tube.
- 2-2 Press the "**DISPLAY**".
Current microprocessor version number of BACK END displayed on the FL tube.
The REGION code will display on the monitor display.
MDD1N : REGION code 1 MPA4P : REGION code 4
- 2-3 Press the "**DISPLAY**".
Current microprocessor version number of FRONT END is displayed on the FL tube.
- 2-4 Press the "**DISPLAY**".
All segment of FL tube light up.
- 2-2 Press the "**DISPLAY**".
Will be displayed "DISPLAY KEY" on FL tube.
- 2-6 Press any keys except "**STANDBY**".
The function name of pressed key is display on the FL tube.
Press each key and confirm that the name of pressed key.
- 2-7 Press "**STANDBY**" to exit the test mode.

3 Dimmer control

Press "**DIMMER**" key and confirm the Dimmer control.

Even press the "**DIMMER**" key, Luminance of FL tube change as follows.

FL tube : Bright → Dark1 → Dark2 → Dark2 → Bright
Center light : ON → ON → ON → OFF → ON

4 Destination setting

	R757	R758	Destination	Region Code	TV mode
MDD1N	OPEN	2.7K	North America	1	NTSC
MPA4P	0 ohm	OPEN	Australia	4	PAL / AUTO

UPGRADE THE FIRMWARE/ TEST MODES

Setting the regional code

- 5 The method of set the REGION CODE with special remote controller. **(RC-484M)**
- 5-1 Press the "**STOP**" key and "**DISPLAY**" key at the same time with NO DISC condition.
Press "**DISPLAY**" key to indicate the "REGION" code on the monitor.
- 5-2 Press "**DVD**" and "**2**" key at same time and press "**RETURN**" key with NO DISC condition.
Then "REGION SET" is displayed on the FL tube.

MDD1N

- 5-3 Press "**1**" key.
"**REGION 1**" is displayed on the FL tube.

MPA4P

- 5-4 Press "**4**" key.
"**REGION 4**" is displayed on the FL tube.
- 5-5 Press "**STANDBY**" key of the DV-CP701 to exit the REGION setting mode.

6 Initialization

- 6-1 Press the "**STOP**" & "**STANDBY**" at the same on the DV-CP701 with NO DISC condition.
- 6-2 It's display "**COMPLETE**" on FL tube after initializing for setting and mechanism setting.
The unit will be going to "**STANDBY**" after display "**COMPLETE**".

NOTE: All of the setting (VIDEO, AUDIO & etc.) will be initialized.
Please refer the "Default Setting" for each destination.

Remove the solder of Laser Diode shorting

Connect the FFC to PWB (NADG-7807) and Pickup.

Remove the solder of short-circuit land (2-points) for the laser diode destruction prevention with the soldering iron.

REMOTE CONTROLLER for
UPGRADE
Part No. **24140484 (RC-484M)**

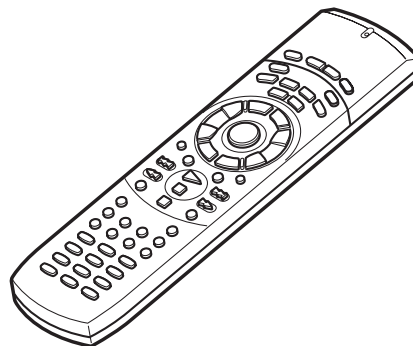

UPGRADE THE FIRMWARE/ TEST MODES

MDD1N Default Setting

Layer 1	Layer 2	Layer 3	Layer 4
Picture	TV Shape Interlaced Setting Progressive Setting	4:3 Letter box 1 1	
Audio	Dolby Digital Out Dynamic Range Control	Dolby Digital Out Linear PCM Out MPEG Out Digital Out Off	Dolby Digital Down Sample On MPEG On
Language	On-Screen Language Disc Menu Language Audio Language Subtitle	English English English English	
Display	On-Screen Display On-Screen Display Color Background Screen Saver	On Sapphire Graphic On	
Operation Setting	Pause/Still Parental Lock PBC Auto Power Off	Auto Off On Off	
Initial Setup	TV Shape On-Screen Language Digital Out	4:3 Letter box English Non	

MPA4P Default Setting

Layer 1	Layer 2	Layer 3	Layer 4
Picture	TV Shape Interlaced Setting Progressive Setting PAL Output Setting	4:3 Letter box 1 1 AUTO	
Audio	Dolby Digital Out Dynamic Range Control	Dolby Digital Out Linear PCM Out MPEG Out Digital Out Off	Dolby Digital Down Sample On MPEG On
Language	On-Screen Language Disc Menu Language Audio Language Subtitle	English English English English	
Display	On-Screen Display On-Screen Display Color Background Screen Saver	On Sapphire Graphic On	
Operation Setting	Pause/Still Parental Lock PBC Auto Power Off	Auto Off On Off	
Initial Setup	TV Shape On-Screen Language Digital Out	4:3 Letter box English Non	

PACKING VIEW

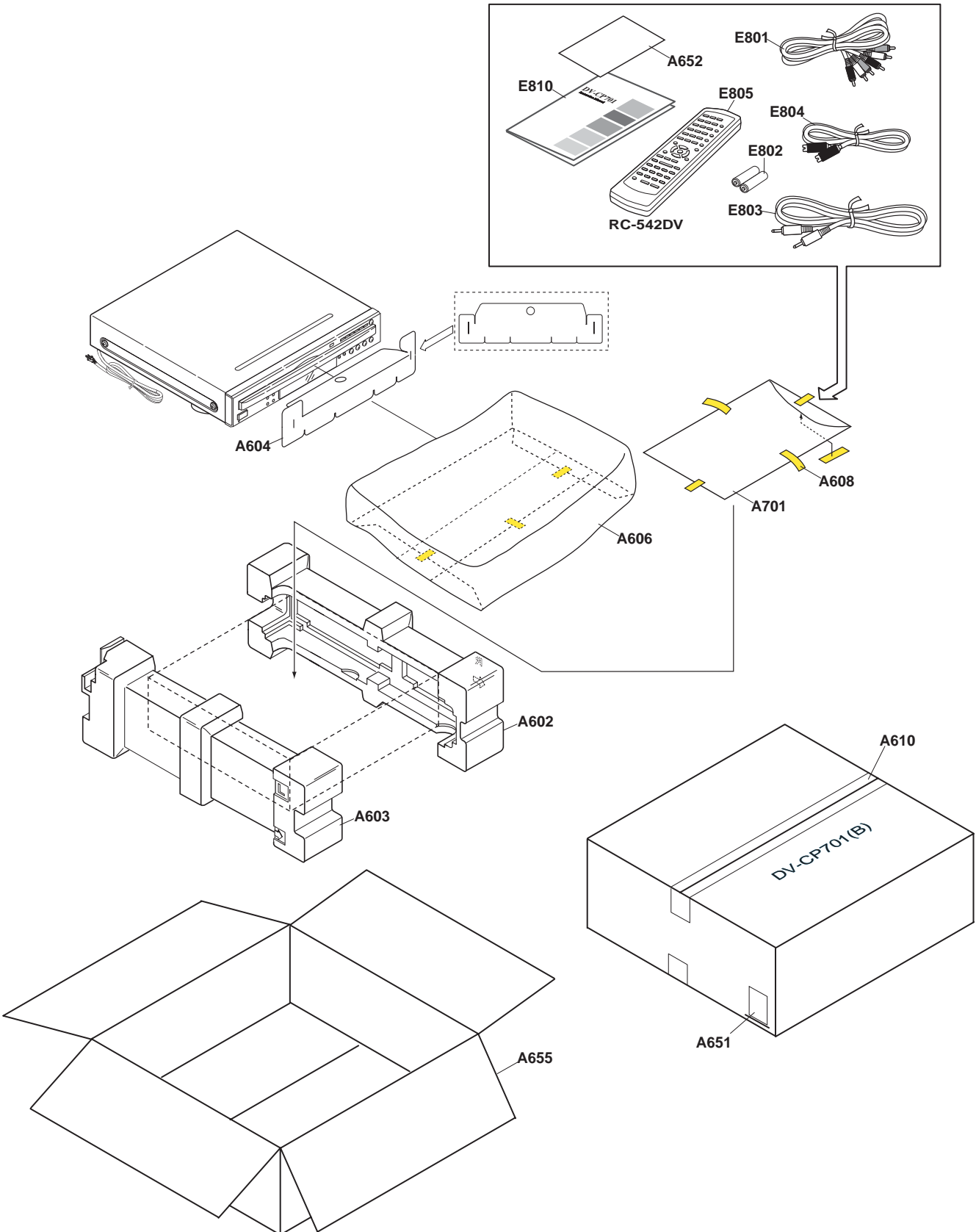

EXPLODED VIEW PARTS LIST

!: Safety part

REF. NO.	PART NAME	DESCRIPTION	PART NO.
A01	Front Panel		1466-1801-0
A01	Front Panel	<S>	1466-1802-0
A02	KNOB (STBY)		2446-3901-0
A02	KNOB (STBY)	<S>	2446-3701-0
A03	KNOB (SEL)		2446-4101-0
A03	KNOB (SEL)	<S>	2446-3801-0
A04	KNOB (EJECT)		2446-4601-0
A04	KNOB (EJECT)	<S>	2446-4401-0
A05	KNOB (PLAY)		2446-4301-0
A05	KNOB (PLAY)	<S>	2446-4001-0
A06	KNOB (DISPLAY)		2446-4501-0
A06	KNOB (DISPLAY)	<S>	2446-4201-0
A07	Retainer	(BDG)	4135-3701-0
A08	Badge		28135244
A08	Badge	<S>	28135245
A12	Clear Plate		3716-8411-0
A12	Clear Plate	<S>	3716-8211-0
A13	Facet	(LIGHT)	3716-8306-0
A14	Facet	(S)	3716-8511-0
A15	Spacer		27270437
A18	Front Bracket	(F)	4135-3181-0
A19	Tapping Screw	2.6TTB+8B(BC)	838426088
A21	Isolation Sheet		4154-6191-0
A22	Plastic Rivet	P-3055B-BL	880048
A25	Tapping Screw	3TTB+8B	838130088
A26	Tapping-tighten screw with washer	3TTW+8B(BC)	831430088
A30	Chassis		1404-7601-0
A31	Holder	KGLS-10RF	27190428A
A32	Clamper	CLAMP WS-2W	27300243
A33	Retainer	(R)	4135-3191-0
A41	Foot	LEG	27175316C
A42	Cushion		4157-0311-0
A46	Cushion		4149-0401-0
A48	Cord Bushing	S-RELIEF #2271	27300750
A50	Tray Panel		4154-6121-0
A50	Tray Panel	<S>	4154-6122-0
A53	Rear Panel	<BMDD>	1404-7501-0
A53	Rear Panel	<BMPA>	1404-7502-0
A53	Rear Panel	<SMDD>	1404-7501-0
A54	Tapping Screw	3TTB+8B(BC)	838430088
A56	Label	(DVD2)	3000-9443-0
A58	Label	(ROM)	29362727
A59	Cushion		28141541
A214	Top Cover		1404-7401-0
A215	Tapping Screw	3TTB+8B(BC) 	838430088
A215	Tapping Screw	3TTB+8B(UN) <S>	838930088
E102	Wire tie		260259
E821	Ferrite Core	GM8T25*15*10	1808-0740-0
F001	Fuse	1.6A-UL/T-237 <MDD>	252158
F001 or	Fuse	1.6A-T/UL-ST2 <MDD>	252252
F001	Fuse	2.5A-SE-EAK FUSE <MPA>	252075
F001 or	Fuse	2.5A-SE-TL250V <MPA>	252275
P1001	FFC	NCFC5-26003	7012-6553-0
P1101	Connector assy	NSAS-12P0960	20022391210UL
P2001	FFC	NCFC5-141522	7012-6525-0
P2401	FFC	NCFC5-152022	7012-6526-0
P2501	Connector assy	NSAS-14P1093	7012-6527-0
P2901	Connector assy	NSAS-12P1105	7012-6528-0
P702	Connector assy	NSAS-22P1141	7012-6521-0

P707	FFC	NCFC6-063012	7012-6522-0	
P901	Power cord	AS-UC-2 <MDD>	253333VOL	
P901 or	Power cord	AS-UC-2 <MDD>	253332HIT	
P901	Power cord	AS-SAA <MPA>	253197HIT	
P901 or	Power cord	AS-SAA <MPA>	253307VOL	GPE P/N
U1	DVD Main circuit PC board assy	NADG-7807A-1A <MDD, MPA>	1H498507-1A	SVC-7807-1A
U2	Display circuit PC board assy	NADIS-7808-1A <MDD>	SVC-Q0090C-1A	
U2	Display circuit PC board assy	NADIS-7808-1B <MPA>	SVC-Q0090C-1B	
U14	Power supply unit	NGPS-0036-100-120V <MDD>	8910-0740-0	
	Power supply unit	NGPS-0036-100-240V <MPA>	8910-0750-0	
(U2)	Display circuit PC board assy	NADIS-7808-1A <MDD>	1H498508-1A	
(U2)	Display circuit PC board assy	NADIS-7808-1B <MPA>	1H498508-1B	
(U3)	Mechanism control circuit PC board assy	NADG-7809-1A <MDD>	1H498509-1A	
(U3)	Mechanism control circuit PC board assy	NADG-7809-1A <MPA>	1H498509-1B	
(U4)	Video signal output terminal PC board assy	NAVD-7810-1A <MDD>	1H498510-1A	
(U4)	Video signal output terminal PC board assy	NAVD-7810-1B <MPA>	1H498510-1B	
(U5)	Audio signal output terminal PC board assy	NAAF-7811-1A <MDD>	1H498511-1A	
(U5)	Audio signal output terminal PC board assy	NAAF-7811-1B <MPA>	1H498511-1B	
(U6)	Disc select switch PC board assy	NASW-7812-1A <MDD>	1H498512-1A	
(U6)	Disc select switch PC board assy	NASW-7812-1B <MPA>	1H498512-1B	
(U7)	Key operation switch PC board assy	NASW-7813-1A <MDD>	1H498513-1A	
(U7)	Key operation switch PC board assy	NASW-7813-1B <MPA>	1H498513-1B	
(U8)	Standby switch PC board assy	NASW-7814-1A <MDD>	1H498514-1A	
(U8)	Standby switch PC board assy	NASW-7814-1B <MPA>	1H498514-1B	
(U9)	LED display PC board assy	NADIS-7815-1A <MDD>	1H498515-1A	
(U9)	LED display PC board assy	NADIS-7815-1B <MPA>	1H498515-1B	
(U10)	Roulette motor PC board assy	NAETC-7816-1A <MDD>	1H498516-1A	
(U10)	Roulette motor PC board assy	NAETC-7816-1B <MPA>	1H498516-1B	
(U11)	Loading motor PC board assy	NAETC-7817-1A <MDD>	1H498517-1A	
(U11)	Loading motor PC board assy	NAETC-7817-1B <MPA>	1H498517-1B	
(U12)	Disc sensor PC board assy	NAETC-7818-1A <MDD>	1H498518-1A	
(U12)	Disc sensor PC board assy	NAETC-7818-1B <MPA>	1H498518-1B	

: Black color model
<S>: Silver color model
<MDD>: North American and Canadian area only
<MPA>: Australian area only
NSP: Not Service Parts

PACKING PARTS LIST

REF. NO.	PART NAME	DESCRIPTION	PART NO.	
A602	Polyform	L-SIDE	1490-4181-0	29092094A
A603	Polyform	R-SIDE	1490-4191-0	29092095A
A604	Sheet	(DR)	29095795	
A606	Bag		1450-6910-0	29100207
A608	Tape	NITTO NO.29	29110149	
A610	PP Tape	W48 OPP TAPE	29110148	
A651	UPC Label	<B MDD>	3000-9445-0	29363364
A651	EAN Label	<B MPA>	3000-9442-0	29363366
A651	UPC Label	<S MDD>	3000-9631-0	29363365
A652	Warranty Card	<MDD>	29365090A	
A653	Instruction Sheet	(PAC)	29355299	
A655	Carton Box	<B MDD>	1436-2901-0-1	29054026B
A655	Carton Box	<B MPA>	1436-2903-0-1	29054028
A655	Carton Box	<S MDD>	1436-2902-0-1	29054027
E801	Video/ Audio Cable	RCA3P (YWR)	2010379	
E802	Battery	R6/AA(UM-3)	3010054	
E803	Mini Plug Cable	3.5-MINI PLUG (RI)	2010200	

E804	S- Cable	(S CORD)	2010380	
E804 or	S- Cable	TPX3000	2010360	
E805	Remote Controller	RC-542DV	8912-0036-0	24140542
E810	Instruction Manual	E (DVCP701)	4301-7046-0	29343461A

<**B**>: Black color model

<**S**>: Silver color model

<**MDD**>: North American and Canadian area only

<**MPA**>: Australian area only

CHANGER MECHANISM PARTS LIST

REF. No.	PART NAME	DESCRIPTION	PART No.	
M01	Rail		4154-6031-0	24840157A
M02	Loading motor assy	M002+M003	Q0090C-MOTCC	
M03	Tapping screw	3TTB+8B	838130088	
M04	Screw	2.6TTP+4S	833126047	
M06	Rubber Belt	DVCP701	4157-0281-0	
M07	Gear	(PULLEY)	4154-6061-0	
M08	Gear	(A)	4154-6091-0	
M09	Gear	(MAIN)	4154-6071-0	248100087A
M10	Gear	(CAM)	4154-6101-0	
M11	Screw		24840111	
M12	DVD Traverse Mechanism	KHM-280AAA	24801016	
M13	Chassis	(SUB)	4154-6041-0	24802051A
M14	Insulator	(A)	4154-6141-0	
M15	Insulator	(B)	4157-0261-0	
M16	Screw		24840111	
M17	Cap	(CHC)	4154-6161-0	
M18	Yoke	(CHB)	4135-3201-0	
M19	Magnet	(CHB)	4135-3211-0	
M23	Spring		2510-3591-0	24820058
M30	Tray		4154-6011-0	24840158A
M31	Bracket assy	(M)	8901-4650-0	
M31a	Bracket	(M)	8901-4650-0	
M31b	Shaft	(M)	24828038	
M32	Roulette motor assy	M032+M033	Q0090C-MOTPW	
M34	PAN head machine screw	2P+3F(BC)	82142003	
M35	Gear	(WHEEL)	4154-5991-0	
M36	Washer	(B)	24834040	
M37	Tapping screw	3TTB+8B	838130088	
M38	Roller	DVCP701	4154-6131-0	
M39	Roulette		4154-6021-0	24840159A
M40	Screw	SCREW	24840111	
M41	Retainer		4135-3881-0	24822044
M42	Cusion		4157-0451-0	28141541
M50	Arm		4154-6051-0	24814025B

PRINTED CIRCUIT BOARD PARTS LIST
U1: DVD MAIN CIRCUIT PC BOARD (NADG-7807)

CIRCUIT NO.	PART NO.	DESCRIPTION	REMARK
ICs			
Q1001	3131-9990-0	CXD1881BR	22241902R3
Q1002	22241676R2	NJM2115V	
Q1101	3132-0020-0	FAN8042	22241905R3
Q1102	3132-0030-0	BA4510FV	22241907R2
Q1201	3132-0040-0	CXD1885Q	22241903R3
Q1251	3132-0050-0	IC41LV16100-50T, EDO-DRAM	22241909R2
Q2001	3132-0060-0	M65783AFP	22241904R3
Q2002	22241642R2	S-80127CNMC-JKM-T2	
Q2003	3132-0290-0	IS24C08-3Z EEPROM	22241951R2
Q2301	3132-0090-0	TC74VCX162373FT	22241896R2
Q2302	3132-0100-0	MX29LV160ABTC-90, Need Prewriting	22241906R3
Q2303	3132-0110-0	IC42S16400-7T, SDRAM	22241910R2
Q2401	3132-0120-0	NJM2373AF	22241897R2
Q2501	3132-0130-0	TC74VHCT125AFT	22241894R2
Q2502	3132-0140-0	TC7SZ125FU	22241895R2
Q2601	3132-0150-0	BU2288FV, Clock gen.	22241911R2
Q2901	22278033ER2NE	MPC29M33T, Regulator	
Q2902	3132-0170-0	MPC2918T, Regulator	22278018ER2NE
Q2903	3132-0170-0	MPC2918T, Regulator	22278018ER2NE
Q2904	22278033ER2NE	MPC29M33T, Regulator	
Transistors			
Q1003	2216520R2	2SK3019	
Q1004	2216520R2	2SK3019	
Q1005	2216520R2	2SK3019	
Q1006	2216400R2	2SB1132	
Q1007	2216400R2	2SB1132	
Q2402	2216410R2	2SA1774	
Q2403	2216410R2	2SA1774	
Q2404	2216410R2	2SA1774	
Q2405	2216410R2	2SA1774	
Q2406	2216410R2	2SA1774	
Capacitors			
C1013	356742209R2	CEWX16V-22M	
C1022	356742209R2	CEWX16V-22M	
C1026	356741009R2	CEWX16V-10M	
C1032	356742209R2	CEWX16V-22M	
C1039	356724709R2	CEWX6.3V-47M	
C1041	356741009R2	CEWX16V-10M	
C1042	356741009R2	CEWX16V-10M	
C1043	356724709R2	CEWX6.3V-47M	
C1045	356741009R2	CEWX16V-10M	
C1046	356741009R2	CEWX16V-10M	
C1047	356742209R2	CEWX16V-22M	
C1050	356721019R2	CEWX6.3V-100M	
C1052	356742209R2	CEWX16V-22M	
C1053	356780109R2	CEWX50V-1M	
C1106	356742209R2	CEWX16V-22M	
C1109	356742209R2	CEWX16V-22M	
C1111	356741009R2	CEWX16V-10M	(DISC judging is slow.)
C1116	332102235R1	CK725BIH-223K1	473K to 223K (#1861)
C1112	356741009R2	CEWX16V-10M	
C1234	356742209R2	CEWX16V-22M	
C1235	356722209R2	CEWX6.3V-22M	
C1236	356721019R2	CEWX6.3V-100M	
C1237	356721019R2	CEWX6.3V-100M	
C1238	356741009R2	CEWX16V-10M	
C1257	356721019R2	CEWX6.3V-100M	
C2026	356721019R2	CEWX6.3V-100M	
C2027	356721019R2	CEWX6.3V-100M	
C2307	356721019R2	CEWX6.3V-100M	
C2316	356741009R2	CEWX16V-10M	
C2401	356721019R2	CEWX6.3V-100M	

C2403	356721019R2	CEWX6.3V-100M
C2415	356741009R2	CEWX16V-10M
C2418	356721019R2	CEWX6.3V-100M
C2601	356722209R2	CEWX6.3V-22M
C2602	356721019R2	CEWX6.3V-100M
C2901	356721019R2	CEWX6.3V-100M
C2902	356721019R2	CEWX6.3V-100M
C2903	356721019R2	CEWX6.3V-100M
C2904	356721019R2	CEWX6.3V-100M
C2905	356721019R2	CEWX6.3V-100M
C2907	3567A2219R2	CEWX4V-220M
C2906	356721019R2	CEWX6.3V-100M

Coils

L1001	231237K470R2	NCH-1479
L1002	231237K470R2	NCH-1479
L1201	231237M022R2	NCH-1471
L1202	231237M022R2	NCH-1471
L1203	231237M022R2	NCH-1471
L1204	231237M022R2	NCH-1471
L1251	231237M022R2	NCH-1471
L2001	231237M022R2	NCH-1471
L2002	231237M022R2	NCH-1471
L2301	231237M022R2	NCH-1471
L2302	231237M022R2	NCH-1471
L2401	231237M022R2	NCH-1471
L2404	231237M022R2	NCH-1471
L2601	230949R2	BLM21P221SG
L2602	230949R2	BLM21P221SG
L2901	231237M022R2	NCH-1471
L2902	231237M022R2	NCH-1471
L2903	231237M022R2	NCH-1471
L2904	231237M022R2	NCH-1471

Sockets

P1001	2101-1414-0	NSCT-26P2671	25052775R2
P2001B	2101-1413-0	NSCT-14P2684	25052788R2
P2401B	2101-1412-0	NSCT-15P2685	25052789R2

Plugs

P1101	25055979R2	NPLG-6P932
P2501A	25055980R2	NPLG-7P933
P2901A	25055979R2	NPLG-6P932

Resistors

R1117	435031032R1	RN72K1J-103FE	(DISC judging is slow.)
R1118	435031032R1	RN72K1J-103FE	5% to 1% Error (#5601)
R2416	435031522R1	RN72K1J-152FE	5% to 1% Error (#5601)
R2418	435032712R1	RN72K1J-271FE	
R2419	435031522R1	RN72K1J-152FE	
R2421	435032712R1	RN72K1J-271FE	
R2422	435031522R1	RN72K1J-152FE	
R2424	435032712R1	RN72K1J-271FE	
R2425	435031522R1	RN72K1J-152FE	
R2427	435032712R1	RN72K1J-271FE	
R2428	435031522R1	RN72K1J-152FE	

C-R Network

R1001	43474415204R1	RM4KJ152X04
R1002	43474400004R1	RM4KJ000X04
R1205	43474410104R1	RM4KJ101X04
R1206	43474410104R1	RM4KJ101X04
R1208	43474410104R1	RM4KJ101X04
R1209	43474433004R1	RM4KJ330X04
R1210	43474410104R1	RM4KJ101X04
R1211	43474410104R1	RM4KJ101X04
R1212	43474418104R1	RM4KJ181X04
R1213	43474410304R1	RM4KJ103X04
R1234	43474410104R1	RM4KJ101X04
R1235	43474410104R1	RM4KJ101X04
R1236	43474410104R1	RM4KJ101X04

R1237	43474410104R1	RM4KJ101X04	
R1238	43474410104R1	RM4KJ101X04	
R1241	43474410104R1	RM4KJ101X04	
R1251	43474410104R1	RM4KJ101X04	
R1252	43474410104R1	RM4KJ101X04	
R1253	43474410104R1	RM4KJ101X04	
R1254	43474410104R1	RM4KJ101X04	
R1291	8911-0020-0	RM6KJ103X08	43474610308R1
R1292	8911-0020-0	RM6KJ103X08	43474610308R1
R1293	8911-0020-0	RM6KJ103X08	43474610308R1
R2022	43474447004R1	RM4KJ470X04	
R2023	43474447004R1	RM4KJ470X04	
R2025	43474447004R1	RM4KJ470X04	
R2035	43474447004R1	RM4KJ470X04	
R2038	43474415004R1	RM4KJ150X04	
R2039	43474415004R1	RM4KJ150X04	
R2040	43474415004R1	RM4KJ150X04	
R2041	43474415004R1	RM4KJ150X04	
R2042	43474415004R1	RM4KJ150X04	
	Resonator		
X2601	3010353R2	FCX-03-27MHz	

U2: DISPLAY CIRCUIT PC BOARD (NADIS-7808-1A/-1B)

CIRCUIT NO.	PART NO.	DESCRIPTION	REMARK
	IC		
Q801	22241814R3	MPD780232GC-070-8BT	
	Transistors		
Q805	2216470R2	DTC114YKA	
Q805 or	2216260R2	RN1407	
Q805 or	2216340R2	KRC107S	
Q806	2213145R2	2SC2712-GR	
	FL Tube		
Q802	2460-2020-0	HNV-12SM34	212236
	Remote sensor		
Q808	481M-7138-3	RPM7138	241346
	Resonator		
X801	3010343	CSTS0500MG06	
	Plugs		
P704	2101-1417-0	NPLG-11P949	25055997
P804A	25055443	NPLG-5P425	
P805A	25055442	NPLG-4P424	
	Capacitors		
C801	394641007	CE04W16V10M(VR)	
C804	394621017	CE04W6.3V100M(VR)	
C820	394680227	CE04W50V2.2M(VR)	
	FL Holder		
Q802A	4154-6111-0		27191195
	Resistor		
R846	4717-4R7J-1	RS1/2WBJ-4.7	443520474M
	Tapping screw		
Q802B	838430068	3TTB+6B(BC)	

U3: MECHANISM CONTROL CIRCUIT PC BOARD (NADG-7809)

CIRCUIT NO.	PART NO.	DESCRIPTION	REMARK
	ICs		
Q701	3132-0190-1	MPD780053GC-141-8BT	22241966R3
Q702	3132-0200-0	S-80130CLMC-JIP-T2	22241924R2
Q704	22240239	TA7291S	
Q705	22240239	TA7291S	
	Transistors		
Q703	2216480R2	DTA114YKA	
Q703 or	2216360R2	RN2407	
Q703 or	2216350R2	KRA107S	
Q706	2216470R2	DTC114YKA	
Q706 or	2216260R2	RN1407	
Q706 or	2216340R2	KRC107S	

Q707	2214373R2	2SA1162-O	
Q708 or	2216260R2	RN1407	
Q708 or	2216340R2	KRC107S	
Q709	2216470R2	DTC114YKA	
Q709 or	2216260R2	RN1407	
Q709 or	2216340R2	KRC107S	
Q710	2213145R2	2SC2712-GR	
Q711	2213145R2	2SC2712-GR	
Q712	2216470R2	DTC114YKA	
Q712 or	2216260R2	RN1407	
Q712 or	2216340R2	KRC107S	
Q713	2211705	2SD655-E	
Q714	2211705	2SD655-E	
Q715	2216480R2	DTA114YKA	
Q715 or	2216360R2	RN2407	
Q715 or	2216350R2	KRA107S	
Diodes			
D701	224490270R2	UDZ2.7B, Zener	
D702	224490220R2	UDZ2.2B, Zener	
D703	224550430R2	UDZS4.3B, Zener	
D731	223269R2	1SS355	
D731 or	223234R2	1SS352	
D732	224550510R2	UDZS5.1B, Zener	
D733	223269R2	1SS355	
D733 or	223234R2	1SS352	
D734	223269R2	1SS355	
D734 or	223234R2	1SS352	
Coils			
L701	1803-0075-0	NCH-3608K470, Choke	231333K470
L702	1803-0075-0	NCH-3608K470, Choke	231333K470
Plugs			
P2501B	25055371	NPLG-7P354	
P2901B	25055370	NPLG-6P353	
P708A	2101-1451-0	NPLG-2P940	25055988
Socket AS			
P701A	7012-6540-0	NSAS-6P1140	2002A290625UL
P704A	7012-6542-0	NSAS-22P1126	2002E242215UL
P710A	7012-6550-0	NSAS-30P1102	2004C193060UL
Sockets			
P707A	25052202	NSCT-6P2099	
P707Aor	25051813	NSCT-6P1600	
P707Aor	2101-1421-0	NSCT-6P1802	25052015
Push switches			
S701	5200-4862-0-01	NPS-111-S679	25035716
S702	5200-4862-0-01	NPS-111-S679	25035716
S703	5200-4862-0-01	NPS-111-S679	25035716
Electric capacitors			
C703	355741017	CE04W16V100M(5L)	
C704	355741017	CE04W16V100M(5L)	
C711	355741007	CE04W16V10M(5L)	
C713	355741007	CE04W16V10M(5L)	
C715	355741007	CE04W16V10M(5L)	
C717	355741007	CE04W16V10M(5L)	
C719	355741007	CE04W16V10M(5L)	
C721	355741007	CE04W16V10M(5L)	
C729	355721017	CE04W6.3V100M(5L)	
C731	355780107	CE04W50V1M(5L)	
C767	355741017	CE04W16V100M(5L)	
C768	355721017	CE04W6.3V100M(5L)	
Resistors			
R709	415470474	R25J-4.7	
R715	415470474	R25J-4.7	
Resonator			
X701	2703-0870-0	CSTLS4M50G56-A0	3010379

CIRCUIT NO.	PART NO.	DESCRIPTION	REMARK
	ICs		
Q201	22241767R2	LA73054	
Q411	22274004HR2TO	TC74VHCU04FT	
	Transistors		
Q202	2216470R2	DTC114YKA	
Q202 or	2216260R2	RN1407	
Q202 or	2216340R2	KRC107S	
Q203	2216480R2	DTA114YKA	
Q203 or	2216360R2	RN2407	
Q203 or	2216350R2	KRA107S	
	Coils		
L201	230958R1	BK1608LM182-T, EMI Filter	
L202	230958R1	BK1608LM182-T, EMI Filter	
L203	230958R1	BK1608LM182-T, EMI Filter	
L204	230958R1	BK1608LM182-T, EMI Filter	
L205	230958R1	BK1608LM182-T, EMI Filter	
L206	230958R1	BK1608LM182-T, EMI Filter	
L221	231237K221R2	NCH-1482, EMI Filter	
L404	231237M022R2	NCH-1471, Choke	
L405	230958R1	BK1608LM182-T, EMI Filter	
	Pin jacks		
P201	2113-2017-0	NPJ-3PDGLR511	25045721
P202A	25045656	NPJ-5PDBY456	
P402	25045548	NPJ-1PDOR369	
	Socket AS		
P403A	7012-6551-0	NSAS-4P1100	2009990769UL
	Sockets		
P2401A	25052352	NSCT-15P2433	25052536
P2401A or	2101-1441-0	NSCT-15P2249	
	Plugs		
P701B	25055989	NPLG-3P941	
	Electric capacitors		
C203	394641007	CE04W16V10M(VR)	
C205	394641007	CE04W16V10M(VR)	
C207	394641007	CE04W16V10M(VR)	
C209	394641007	CE04W16V10M(VR)	
C210	394621017	CE04W6.3V100M(VR)	
C211	394621017	CE04W6.3V100M(VR)	
C212	394621027	CE04W6.3V1000M(VR)	
C213	394624717	CE04W6.3V470M(VR)	
C214	394621027	CE04W6.3V1000M(VR)	
C215	394624717	CE04W6.3V470M(VR)	
C216	394624717	CE04W6.3V470M(VR)	
	Photo coupler		
Q412	24120094	TOTX179	
	Clip		
E201	260224	CP-1S	

U5: AUDIO SIGNAL OUTPUT TERMINAL PC BOARD (NAAF-7811)

CIRCUIT NO.	PART NO.	DESCRIPTION	REMARK
	ICs		
Q401	22241776R2	PCM1742KE	
Q403	22241448R2	NJM4580M-D	
Q404	22241448R2	NJM4580M-D	
Q405	22241448R2	NJM4580M-D	
Q406	22241448R2	NJM4580M-D	
Q413	22241289R2	NJM2370U05	
	Transistors		
Q109	2216480R2	DTA114YKA	
Q109 or	2216360R2	RN2407	
Q109 or	2216350R2	KRA107S	
Q110	2216470R2	DTC114YKA	
Q110 or	2216260R2	RN1407	
Q110 or	2216340R2	KRC107S	
Q407	2216141R2	HN1C03F-B	

Q408	2216141R2	HN1C03F-B
	Coils	
L403	231237M022R2	NCH-1471, Choke
L406	231237M022R2	NCH-1471, Choke
L407	230958R1	BK1608LM182-T, EMI Filter
	Diodes	
D101	223269R2	1SS355
D101 or	223234R2	1SS352
D102	223269R2	1SS355
D102 or	223234R2	1SS352
D103	223269R2	1SS355
D103 or	223234R2	1SS352
D104	223269R2	1SS355
D104 or	223234R2	1SS352
D401	223269R2	1SS355
D401 or	223234R2	1SS352
	Electric capacitors	
C401	394641017	CE04W16V100M(VR)
C402	394641017	CE04W16V100M(VR)
C405	394622217	CE04W6.3V220M(VR)
C406	394622217	CE04W6.3V220M(VR)
C409	394680477	CE04W50V4.7M(VR)
C411	394642207	CE06W16V22M(VR)
C412	394642207	CE06W16V22M(VR)
C419	394682207	CE04W50V22M(VR)
C420	394682207	CE04W50V22M(VR)
C421	394644717	CE04W16V470M(VR)
C422	394644717	CE04W16V470M(VR)
C423	394680107	CE04W50V1.0M(VR)
C425	394622217	CE04W6.3V220M(VR)
C432	394621017	CE04W6.3V100M(VR)
C434	394641007	CE04W16V10M(VR)
C435	394641007	CE04W16V10M(VR)
C441	394644707	CE04W16V47M(VR)
C442	394680107	CE04W50V1.0M(VR)
	Capacitors	
C407	374721044	ECQ-V50V-104J, TF
C408	374721044	ECQ-V50V-104J, TF
C410	374721044	ECQ-V50V-104J, TF
C413	374722215	ECQ-B50V-221K, TF
C414	374722215	ECQ-B50V-221K, TF
C415	374721224	ECQ-B50V-122J, TF
C416	374721224	ECQ-B50V-122J, TF
C417	374722724	ECQ-B50V-272J, TF
C418	374722724	ECQ-B50V-272J, TF
C439	374721024	ECQ-B50V-102J, TF
C440	374721024	ECQ-B50V-102J, TF
	Sockets	
P2001A	25052508	NSCT-14P2405
P2001Aor	25052314	NSCT-14P2211
	Pin jacks	
P401	25045628	NPJ-2PDRW435, Audio out
P602	25045589	NPJ-2PDB400, RI
	Plugs	
P403	25055132	NPLG-2P116
P702	25055449	NPLG-11P431
P702B	25055449	NPLG-11P431
	Resistors	
R455	443521514	RS1/2WBJ-150, Oxide metal
R456	443521514	RS1/2WBJ-150, Oxide metal
R471	443521014	RS1/2WBJ-100, Oxide metal

U6: DISC SELECT SWITCH PC BOARD (NASW-7812)

CIRCUIT NO.	PART NO.	DESCRIPTION	REMARK
	Socket AS		
P802A	7012-6546-0	NSAS-8P1118	200EE390805UL

P806A	7012-6549-0	NSAS-6P1137	200EE340615UL
	Push switch		
S801	25035718	NPS-111-S681	
S802	25035718	NPS-111-S681	
S803	25035718	NPS-111-S681	
S804	25035718	NPS-111-S681	
S805	25035718	NPS-111-S681	
S806	25035718	NPS-111-S681	
S807	25035718	NPS-111-S681	
S808	25035718	NPS-111-S681	

U7: KEY OPERATION SWITCH PC BOARD (NASW-7813)

CIRCUIT NO.	PART NO.	DESCRIPTION	REMARK
	Socket AS		
P804B	7012-6547-0	NSAS-10P1119	2002E341005UL
	Push switches		
S809	25035718	NPS-111-S681	
S810	25035718	NPS-111-S681	
S811	25035718	NPS-111-S681	
S812	25035718	NPS-111-S681	
S813	25035718	NPS-111-S681	
S814	25035718	NPS-111-S681	

U8: STANDBY SWITCH PC BOARD (NASW-7814)

CIRCUIT NO.	PART NO.	DESCRIPTION	REMARK
	Diode		
D803	225321	SLR-342VR, LED Standby	
	Socket AS		
P805B	7012-6548-0	NSAS-8P1120	2002E390805UL
	Push switches		
S815	25035718	NPS-111-S681	
S816	25035718	NPS-111-S681	
S817	25035718	NPS-111-S681	
S818	25035718	NPS-111-S681	
S819	25035718	NPS-111-S681	

U9: LED DISPLAY PC BOARD (NADIS-7815)

CIRCUIT NO.	PART NO.	DESCRIPTION	REMARK
	Transistors		
Q809	2216470R2	DTC114YKA	
Q809 or	2216260R2	RN1407	
Q809 or	2216340R2	KRC107S	
Q810	2216470R2	DTC114YKA	
Q810 or	2216260R2	RN1407	
Q810 or	2216340R2	KRC107S	
	Diodes		
D801	3700-2824-B	SLR-343BBT, LED Green	225419
D802	3700-2824-B	SLR-343BBT, LED Orange	225419
	Holders		
D801A	27191190	(LED)LA-5-6	
D802A	27191190	(LED)LA-5-6	

U10: ROULETTE MOTOR PC BOARD (NAETC-7816)

CIRCUIT NO.	PART NO.	DESCRIPTION	REMARK
	Plug		
P709A	25055440	NPLG-2P422	

U11: LOADING MOTOR PC BOARD (NAETC-7817)

CIRCUIT NO.	PART NO.	DESCRIPTION	REMARK
	Socket AS		
P708B	2002A340420UL	NSAS-4P1138	

U12: DISC SENSOR PC BOARD (NAETC-7818)

CIRCUIT NO.	PART NO.	DESCRIPTION	REMARK
	Socket AS		
P709B	7012-6545-0	NSAS-4P1127	2002E390415UL

	Sockets	
P707B	25052239	NSCT-6P2136
P707Bor	25052052	NSCT-6P1839
P707Bor	25051850	NSCT-6P1637

	Photo interrupter	
Q716	24190046	GP2S28, Disc sensor

	Photo coupler		
Q717	481P-1576-3	RPI-576, Disc stop sens.	24120107

ONKYO CORPORATION

Sales & Product Planning Div. : 2-1, Nisshin-cho, Neyagawa-shi, OSAKA 572-8540, JAPAN
Tel: 072-831-8111 Fax: 072-833-5222

ONKYO U.S.A. CORPORATION

18 Park Way, Upper Saddle River, N.J. 07458, U.S.A.
Tel: 201-785-2600 Fax: 201-785-2650 E-mail: onkyo@onkyousa.com

ONKYO EUROPE ELECTRONICS GmbH

Liegnitzerstrasse 6, 82194 Groebenzell, GERMANY
Tel: +49-8142-4401-0 Fax: +49-8142-4401-555 E-mail: info@onkyo.de

ONKYO CHINA LIMITED

Units 2102-2107, Metroplaza Tower I, 223 Hing Fong Road, Kwai Chung,
N.T., HONG KONG Tel: 852-2429-3118 Fax: 852-2428-9039