

# ONKYO SERVICE MANUAL

## DVD CHANGER MODEL DV-CP704

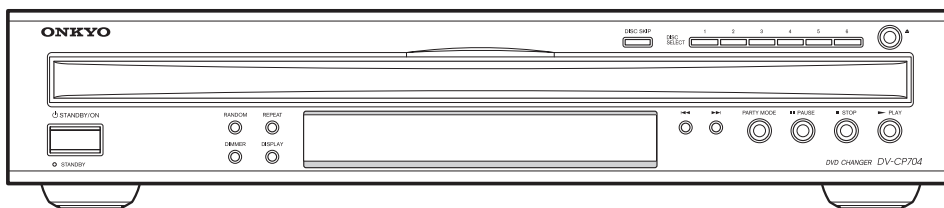

RC-655DV

### Black and Silver models

BCDD, SCDD	120V AC, 60Hz
BCUA, SCUA	100-240V AC, 50/60Hz

### SAFETY-RELATED COMPONENT WARNING!!

COMPONENTS IDENTIFIED BY MARK  ON THE SCHEMATIC DIAGRAM AND IN THE PARTS LIST ARE CRITICAL FOR RISK OF FIRE AND ELECTRIC SHOCK. REPLACE THESE COMPONENTS WITH ONKYO PARTS WHOSE PART NUMBERS APPEAR AS SHOWN IN THIS MANUAL.

MAKE LEAKAGE-CURRENT OR RESISTANCE MEASUREMENTS TO DETERMINE THAT EXPOSED PARTS ARE ACCEPTABLY INSULATED FROM THE SUPPLY CIRCUIT BEFORE RETURNING THE APPLIANCE TO THE CUSTOMER.

## SPECIFICATION

<b>Signal system</b>		Standard NTSC (U.S. model), PAL/AUTO (Australian model)
<b>Frequency response</b>	<b>DVD linear audio</b>	4 Hz - 22 kHz @ 48 kHz sampling rate 4 Hz - 44 kHz @ 96 kHz sampling rate
	<b>CD audio</b>	4 Hz - 20 kHz (44.1 kHz)
<b>Signal-to-noise ratio</b>		95 dB
<b>Audio dynamic range</b>		95 dB
<b>Total harmonic distortion</b>		0.007% (1 kHz)
<b>Wow and Flutter</b>		Below threshold of measurability
<b>Operating conditions</b>	<b>Temperature</b>	5° C to 35° C (41° F to 95° F)
	<b>Installation</b>	Install horizontally
<b>Video outputs</b>	<b>COMPONENT VIDEO</b>	Y: 1.0 V (p-p), 75 ohm, negative sync, RCA/phono x 3 Pb/Pr: 0.7 V (p-p), 75 ohm
	<b>S VIDEO (S-Video)</b>	Y: 0.7 V (p-p), 75 ohm, negative sync, 4-pin mini DIN x 1 C: 0.286 V (p-p), 75 ohm
	<b>VIDEO (composite video)</b>	1.0 V (p-p), 75 ohm, negative sync, RCA/phono x 1
<b>Audio outputs</b>	<b>OPTICAL</b>	-22.5 dBm, optical connector x 1
	<b>COAXIAL</b>	0.5 V (p-p), 75 ohm, RCA/phono x 1
	<b>ANALOG</b>	2.0 V (rms), 540 ohm, RCA/phono x 2
<b>HDMI output</b>		19 pin connector
<b>General</b>	<b>Power supply</b>	120 V AC, 60 Hz (U.S. model) 100 - 240 V AC, 50/60 Hz (Australian model)
	<b>Power consumption</b>	13 W
	<b>Power consumption in Standby mode</b>	0.35 W (U.S. model) 0.35 W (Australian model)
	<b>Weight</b>	5.5 kg (12.1 lbs.)
	<b>Dimensions (W x H x D)</b>	435 X 91 X 432 mm (17-1/8 X 3-9/16 X 17 ins.)
<b>Disc compatibility</b>		Audio CD, DVD-Video, MP3, WMA, JPEG, CD-R/RW, DVD-R/RW (Video Mode), DVD+R/RW (Video Mode). Discs that have not been properly finalized may only be partially playable or not playable at all.

Specifications and features subject to change without notice.

# EXPLODED VIEW

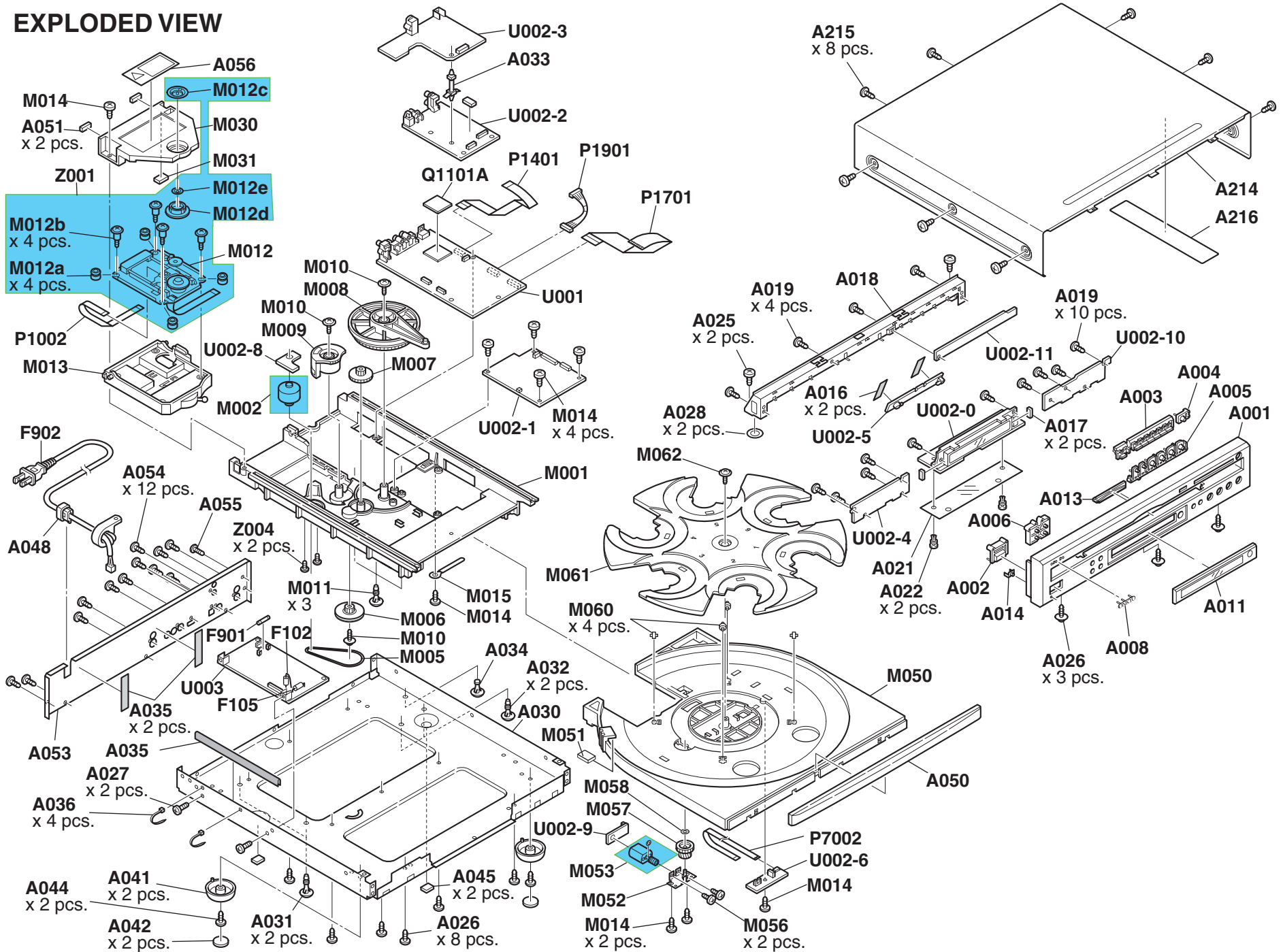

EXPLODED VIEW-2

TRAVERSE MECHA. AS

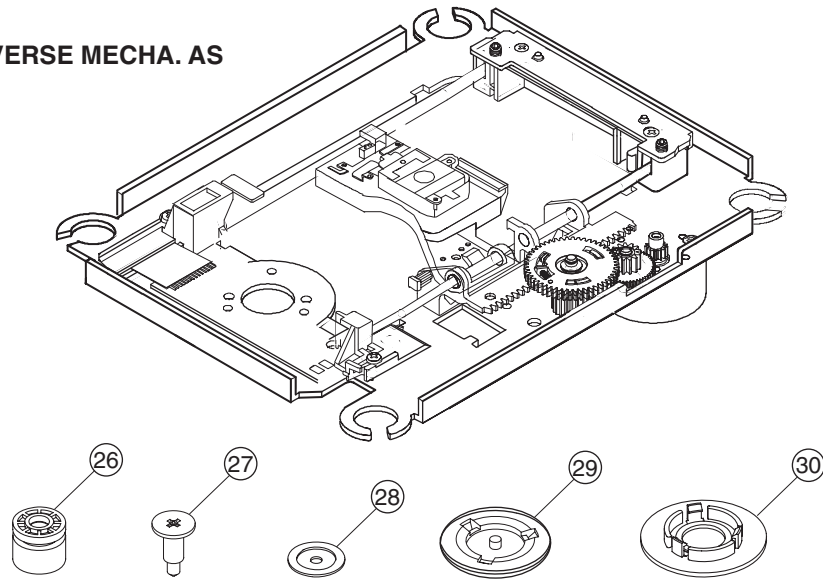

NO.	PART CODE	PART NAME
26	C2G083	Damper-Idle
27	C1H012	SCW-Damper-CR3
28	A7P085	Clamp-T-M12H
29	A7G202	Clamper-H
30	A7G203	Clamper-L

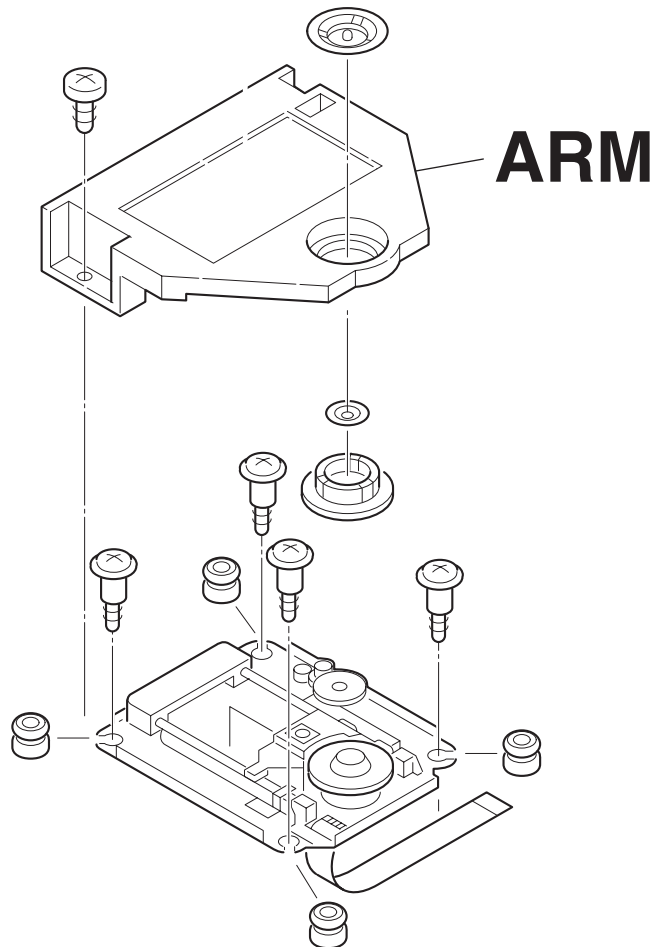

A

B

C

D

# BLOCK DIAGRAM

## Overall

### U001: DVD Main circuit PC board NADG-8875

#### Traversé Mécha

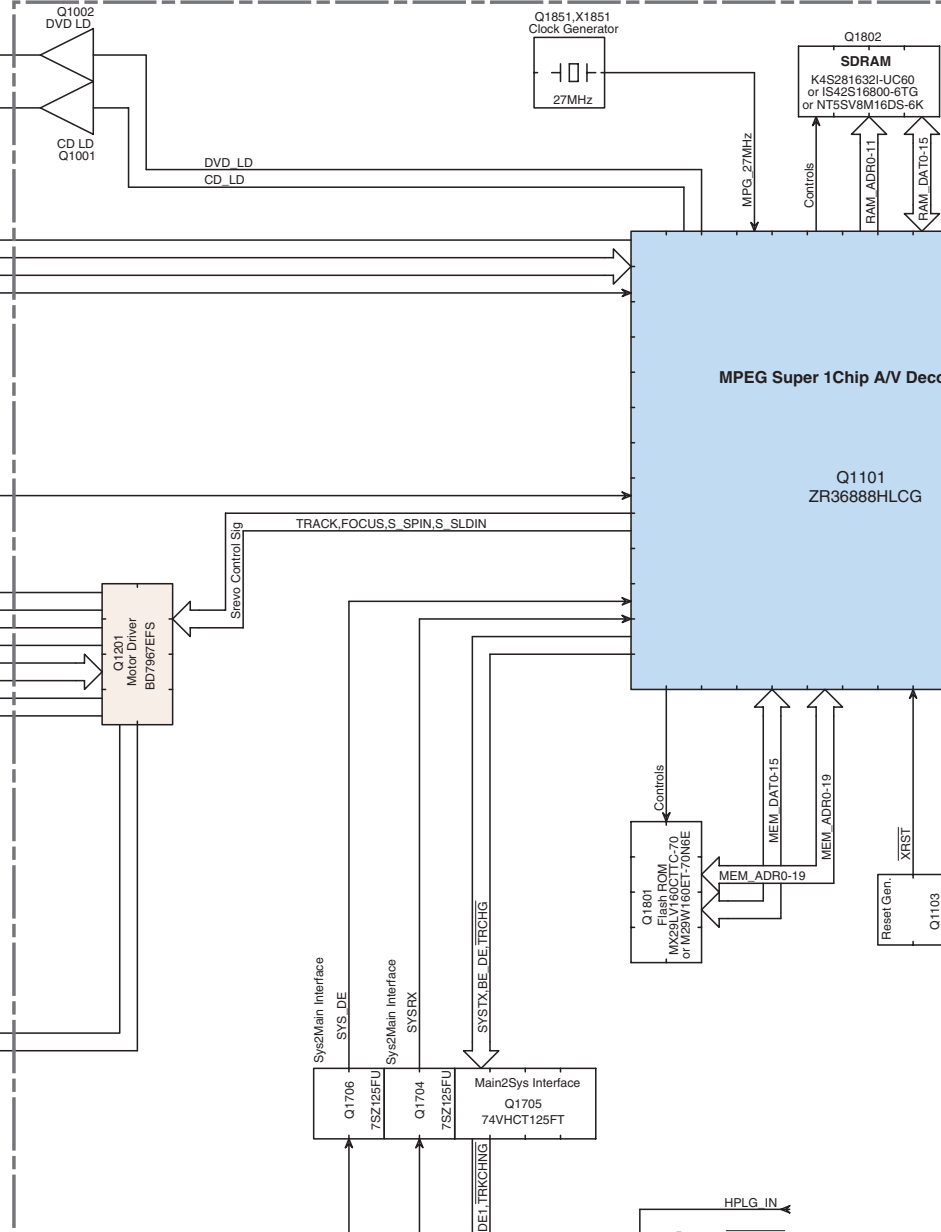
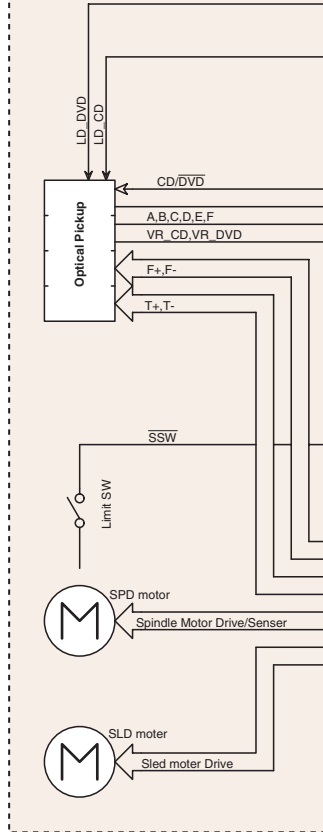

### U002-6: Disc sensor PC board NAETC-8868

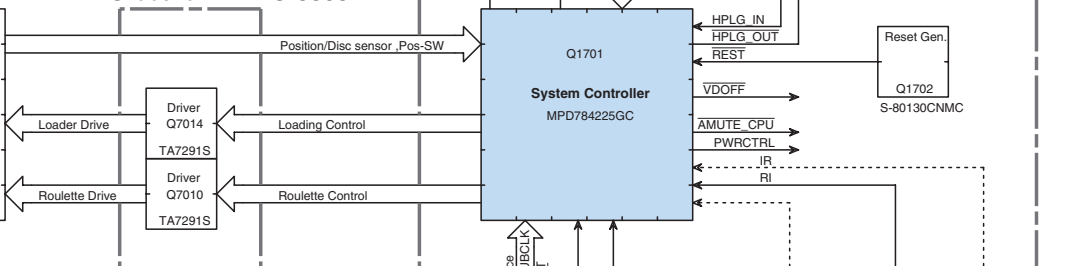
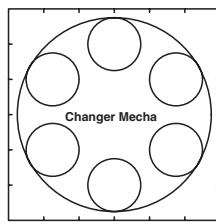

### U002-0: Display circuit PC board NADIS-8859

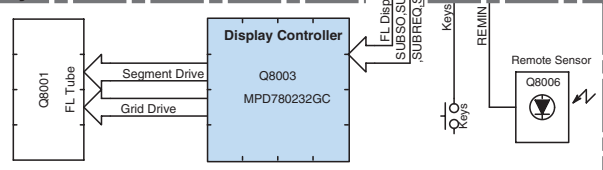

### U002-3: RS-232C PC board

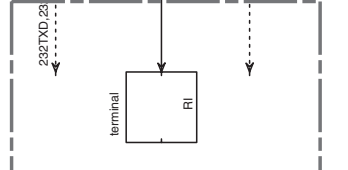

1

2

3

4

5

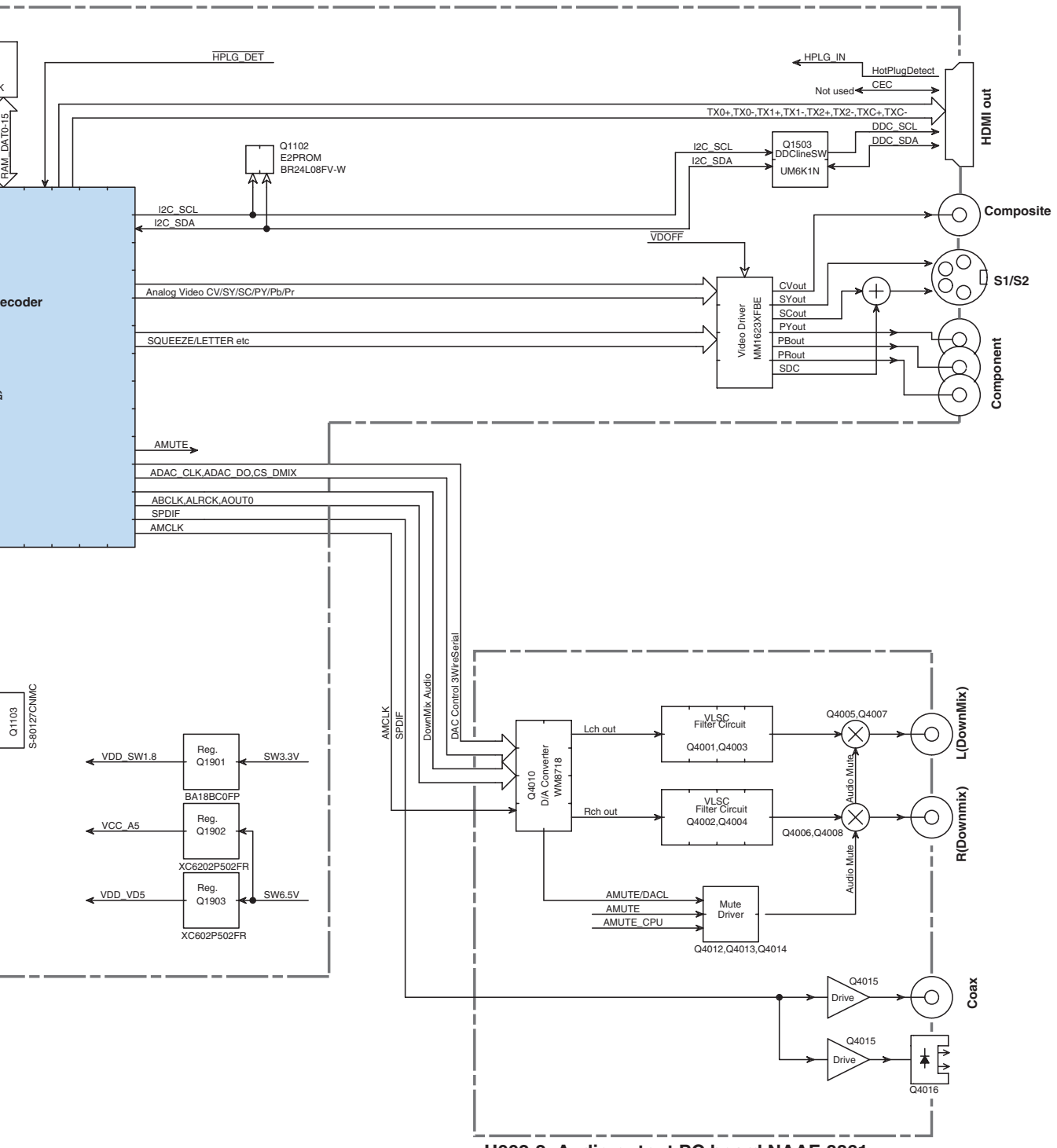

U002-2: Audio output PC board NAAF-8861

U003: Power supply unit  
 NGPS-0074-100-120V <CDD>  
 NGPS-0075-100-240V <CUA>

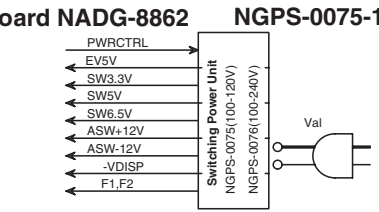

**SCHEMATIC DIAGRAMS-1**  
**DISPLAY SECTION**

**U002-0 Display circuit PC board**

**NADIS-8859**

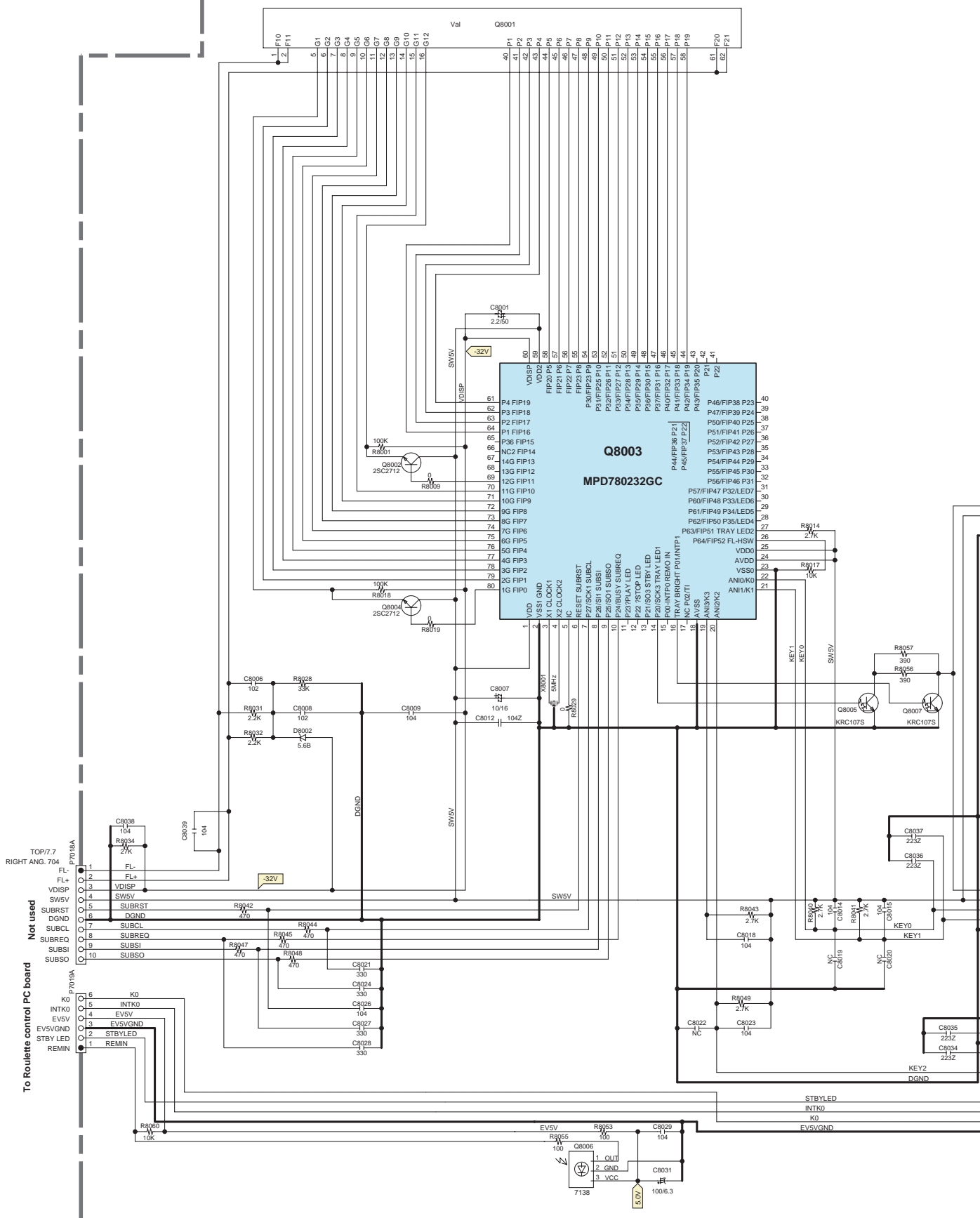

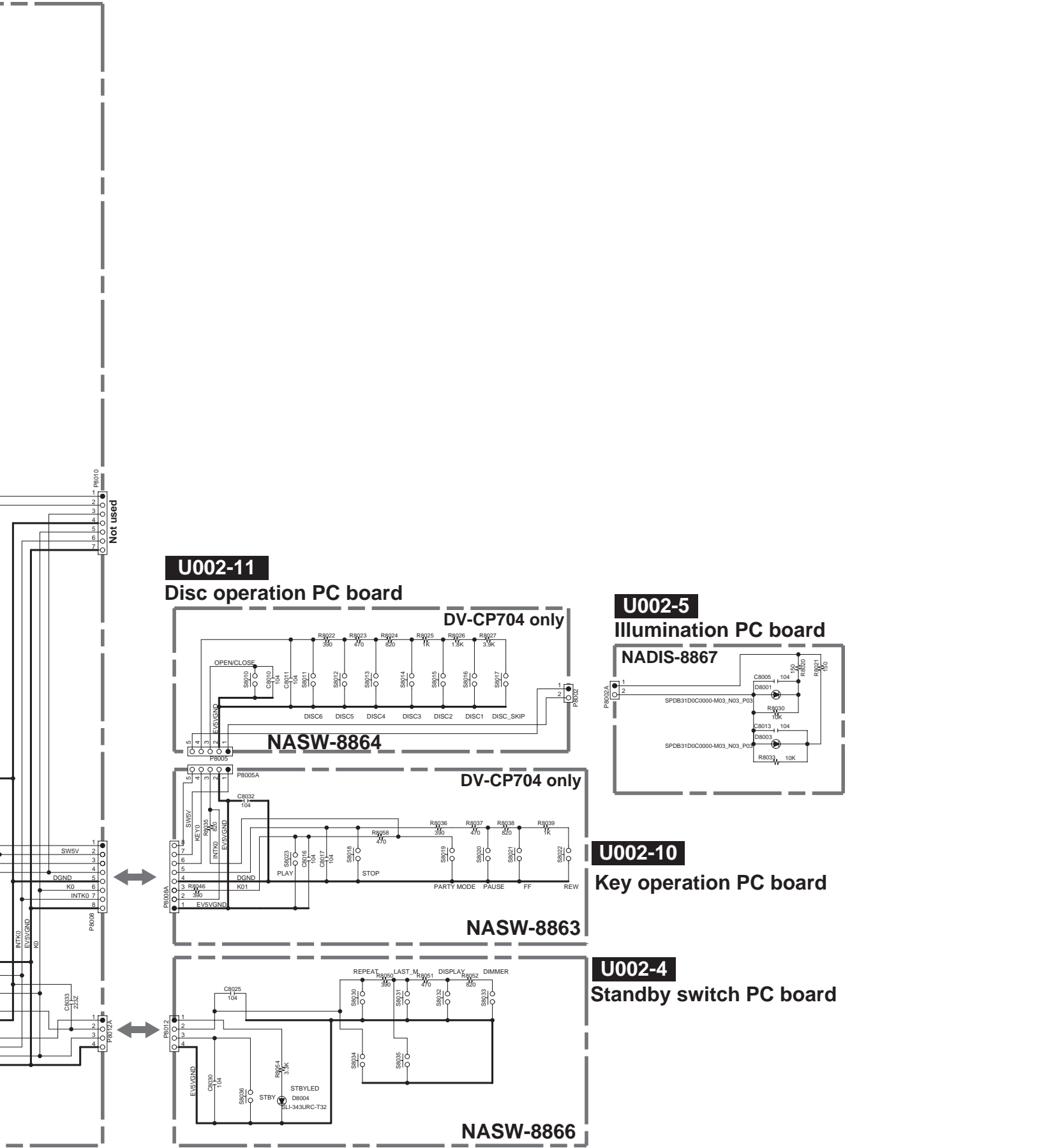

**U002-11**

**Disc operation PC board**

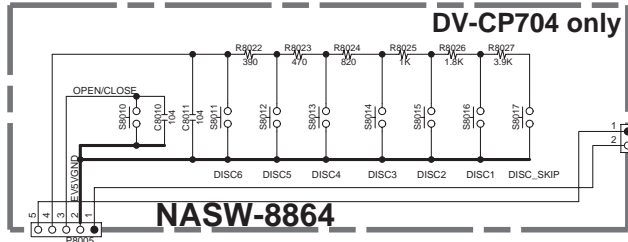

**U002-5**

**Illumination PC board**

**NADIS-8867**

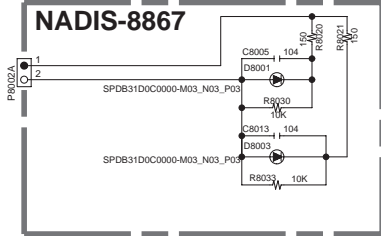

**DV-CP704 only**

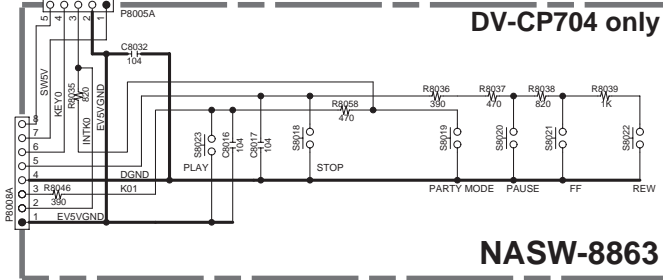

**U002-10**

**Key operation PC board**

**NASW-8863**

**U002-4**

**Standby switch PC board**

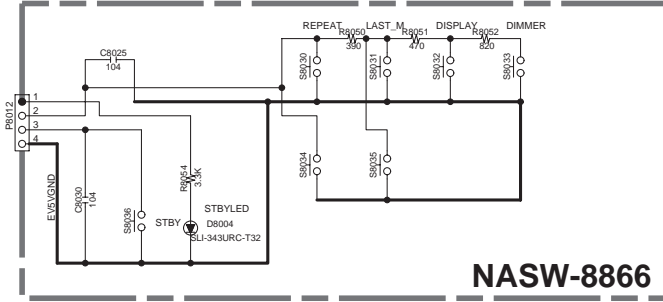

Not used



A

B

C

D

# SCHEMATIC DIAGRAMS-2

# MECHA. & RC-232C CONTROL SECTION

1

**U002-6**  
Disc sensor PC board

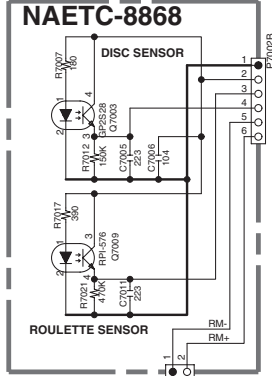

2

**U002-9**  
Roulette motor PC board

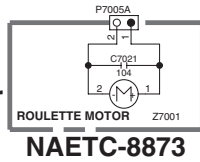

3

**U002-8**  
Loading motor PC board

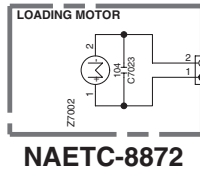

4

5

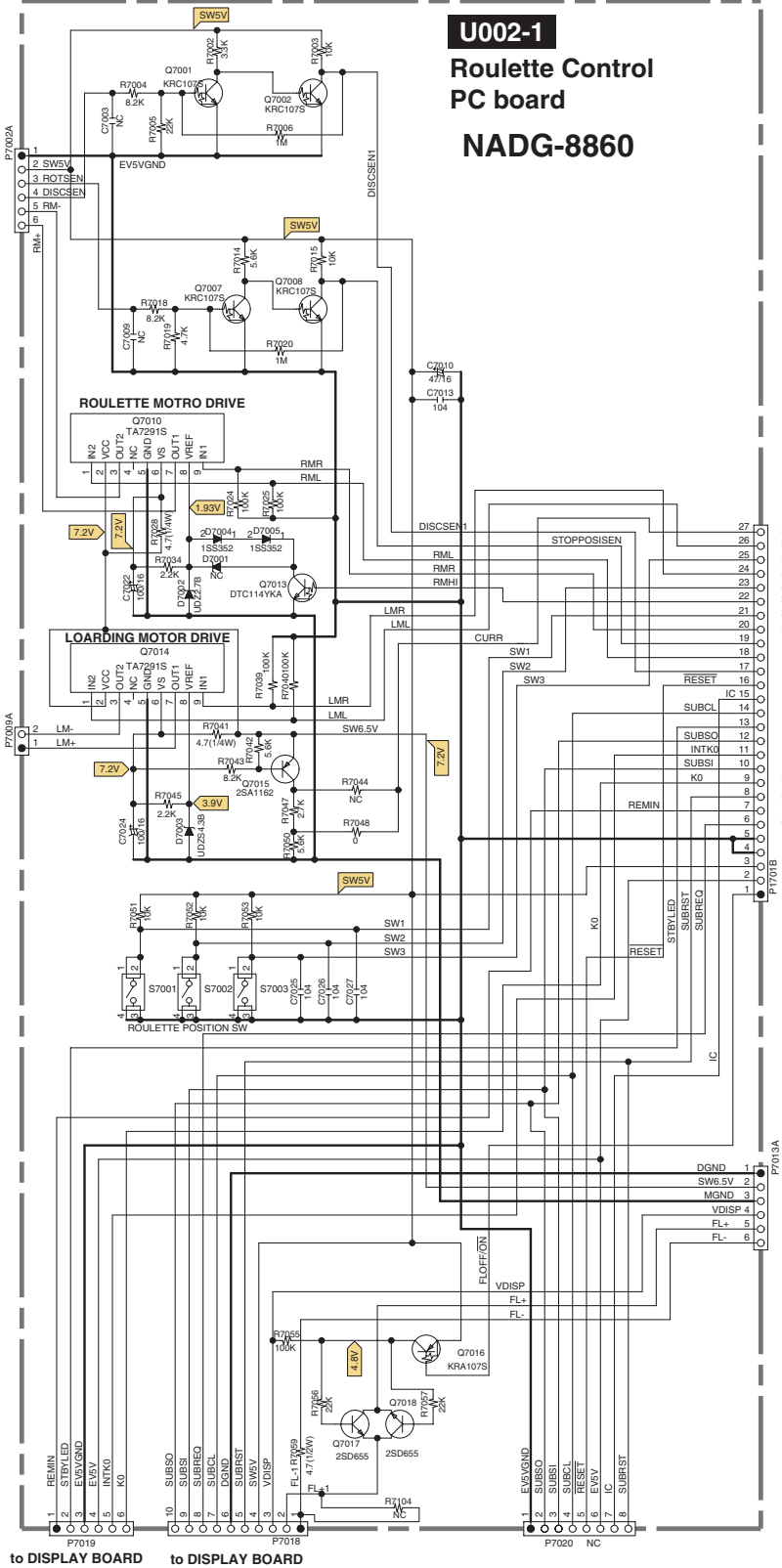

**U00**

from DVD MAIN BOARD

DGND=SW5

**002-3 RI Terminal PC board**  
**NADG-8862**

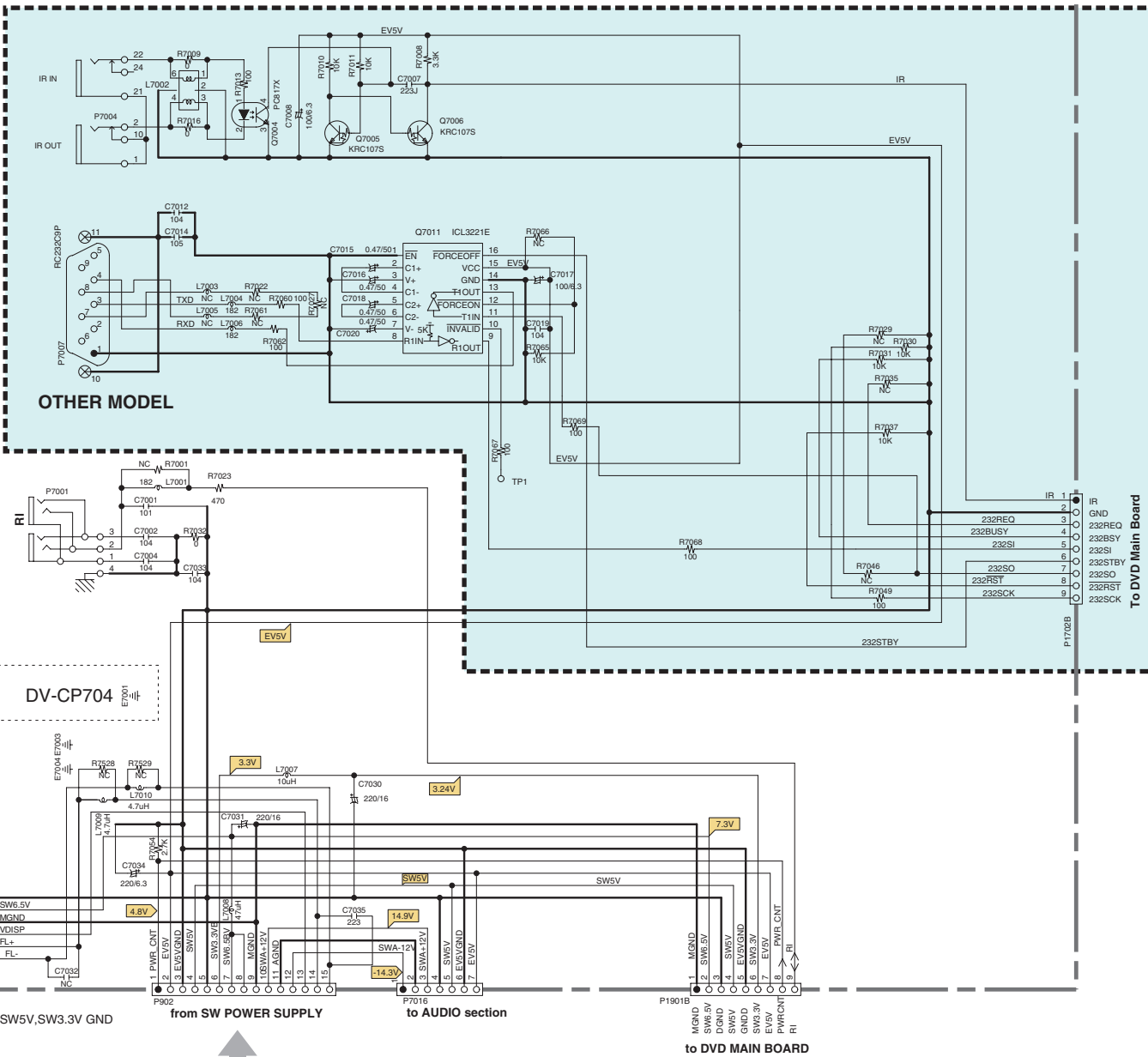

DV-CP704

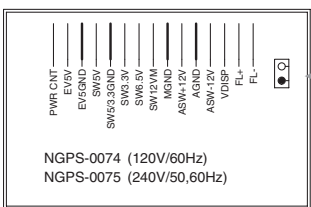

**U003 Power supply unitT**

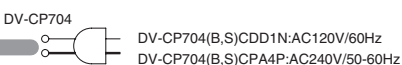

**DV-CP704**  
DV-CP704(B,S)CDD1N:AC120V/60Hz  
DV-CP704(B,S)CPA4P:AC240V/50-60Hz

# SCHEMATIC DIAGRAMS-3

# AUDIO SECTION

1

2

3

4

5

To RI Terminal PC board  
NADG-8862

- 7 EV+5V
- 6 EV5 GND
- 5 SW+5V
- 4 DGND
- 3 A+12V
- 2 AGND
- 1 A-12V

To DVD Main PC board  
NADG-8875

- 1 ADAC DO R4061
- 2 CS\_DMIX 100 R4062
- 3 ADAC\_CLK 100 R4065
- 4 EV5 GND 100
- 5 AMCLK R4066
- 6 EV5 GND 100
- 7 ABCLK R4068
- 8 EV5 GND 100
- 9 AOUT0 R4069
- 10 AMUTE 100 R4070
- 11 ALRCK R4071 100
- 12 AMUTCPU R4073 100
- 13 PWRCTR2 100
- 14 EV5 GND
- 15 SPDIFOUT
- 16 RESET

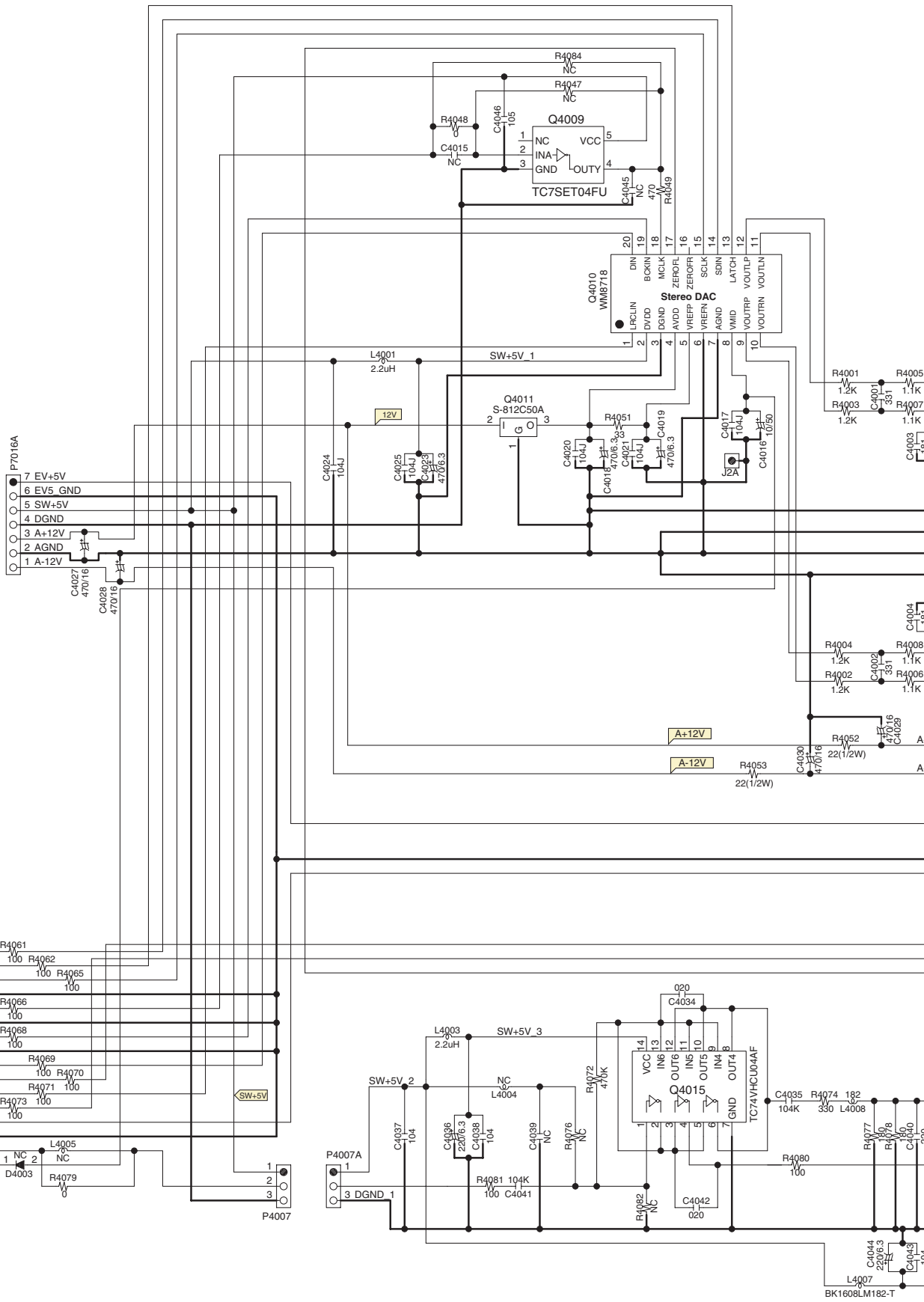

BK1608LM182-T

E

F

G

H

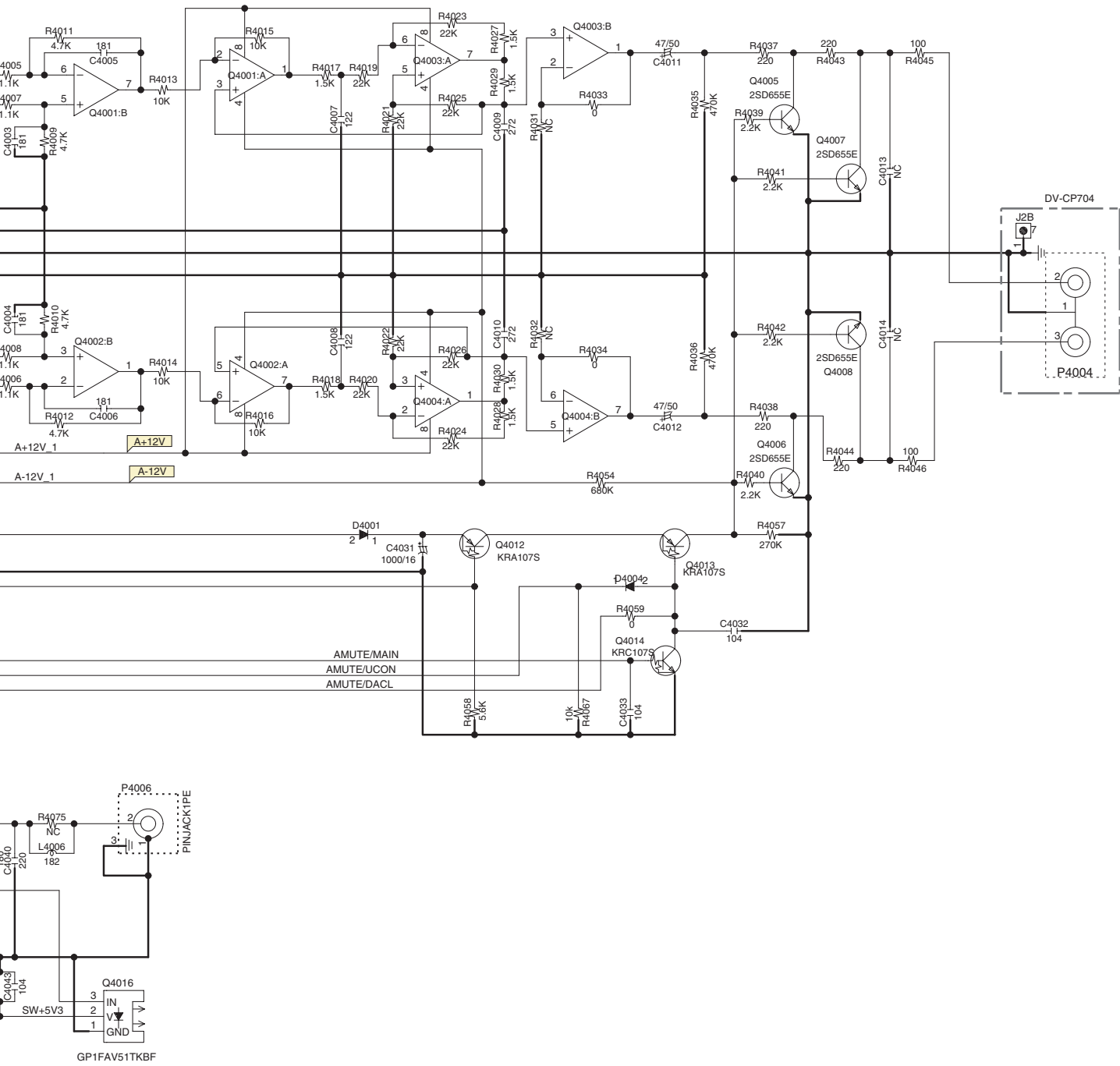

# SCHEMATIC DIAGRAMS-4-2

## POWER SUPPLY UNIT (100-240V CUA) Australian area

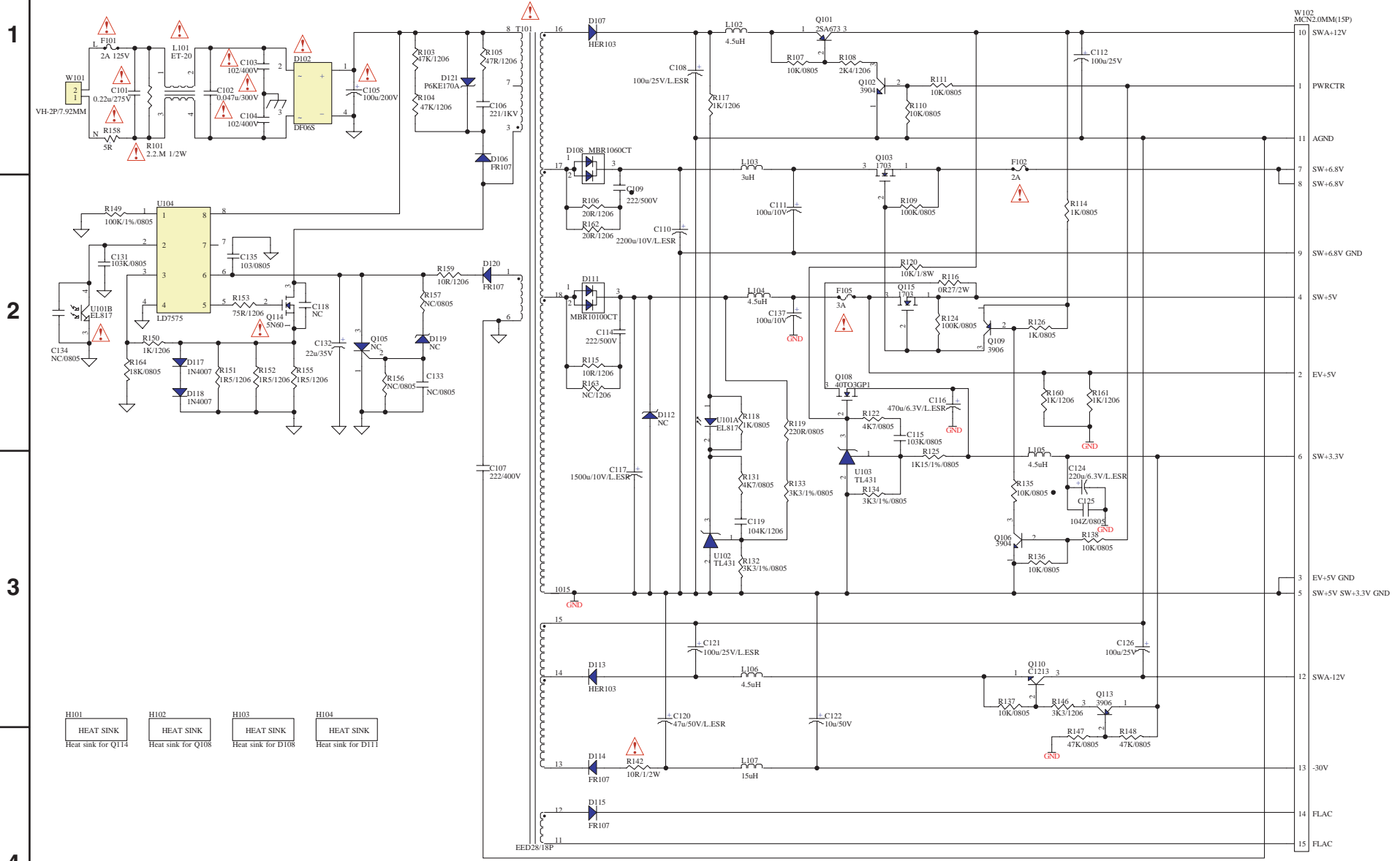

A

B

C

D

E

# SCHEMATIC DIAGRAM-4-1 POWER SUPPLY UNIT For 120V (CDD1N) North American area

1

2

3

4

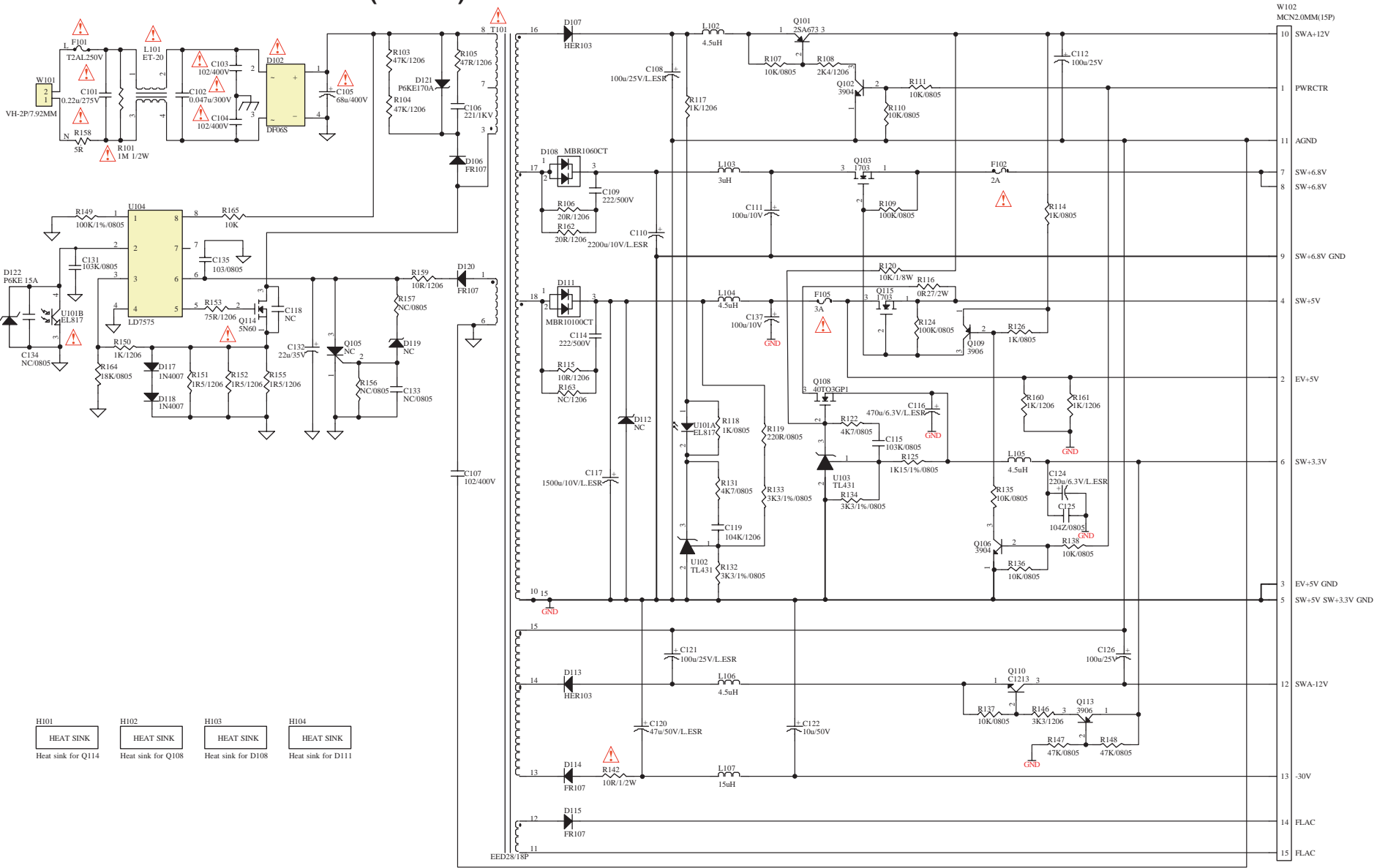

- H101 HEAT SINK  
Heat sink for Q114
- H102 HEAT SINK  
Heat sink for Q108
- H103 HEAT SINK  
Heat sink for D108
- H104 HEAT SINK  
Heat sink for D111

XXXX-XX



E

F

G

H

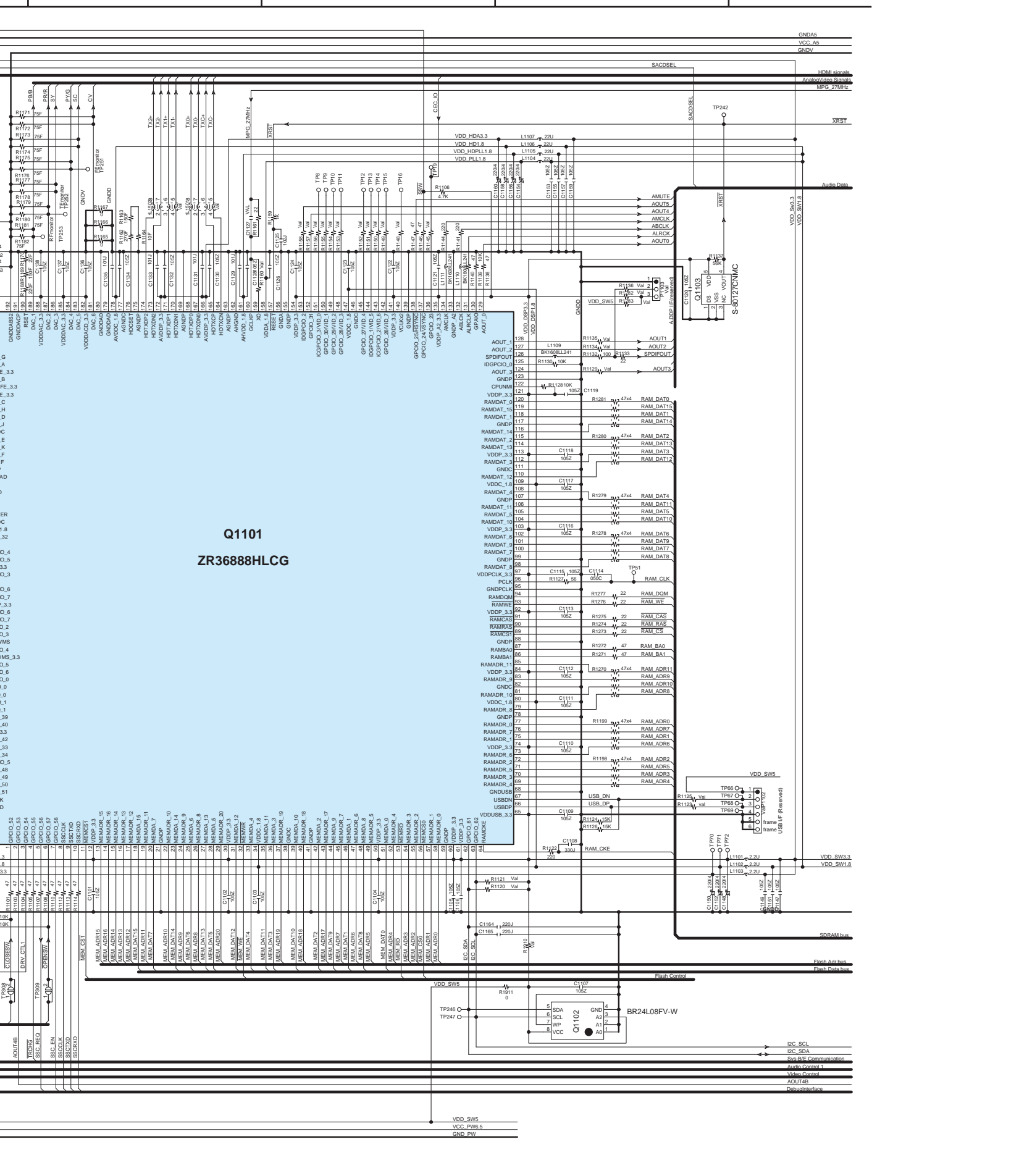

**Q1101**  
**ZR36888HLCG**

S-80177CNIC

BR24L08FV-W



A

B

C

D

**SCHEMATIC  
DIAGRAMS-6  
DVD MAIN SYSTEM  
MICON  
etc. SECTION**

1

**U001  
DVD Main  
circuit PC board  
NADG-8875**

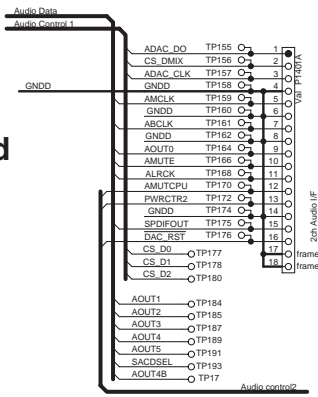
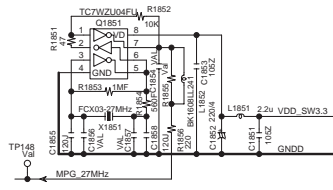

2

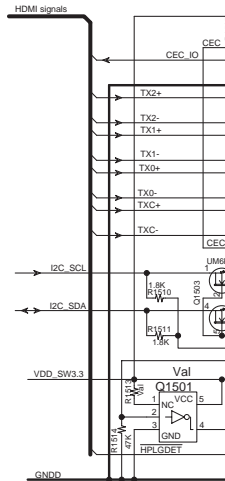
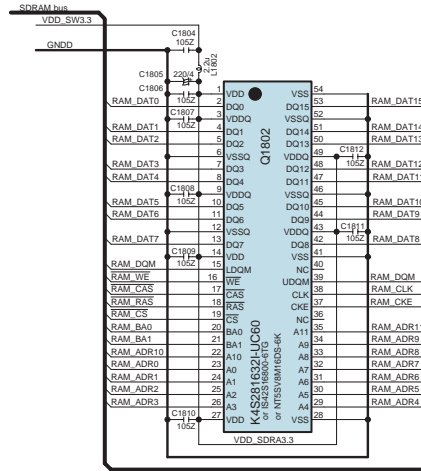

3

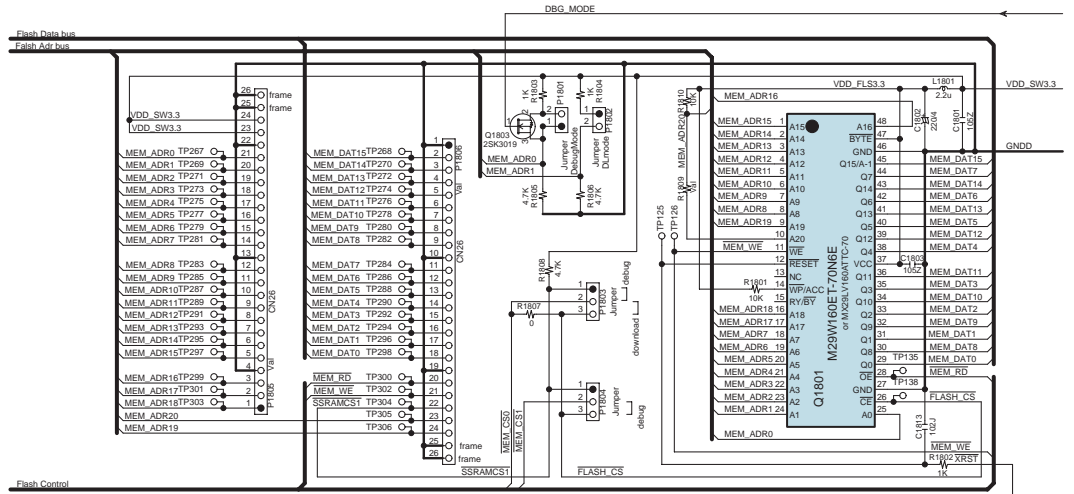

4

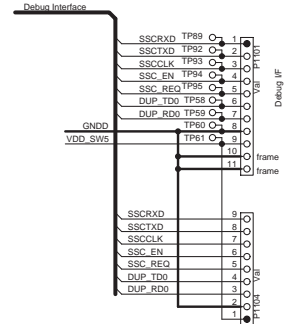

5

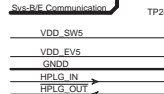
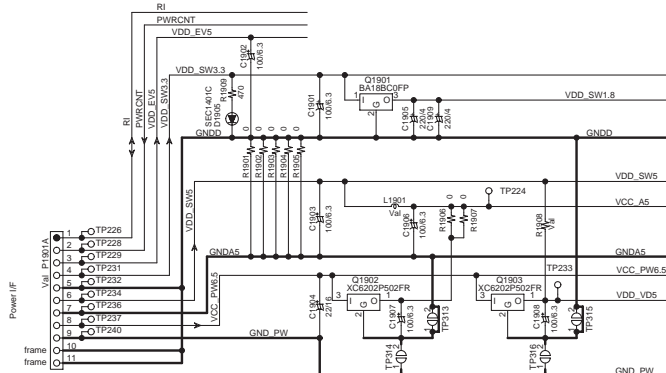

E

F

G

H

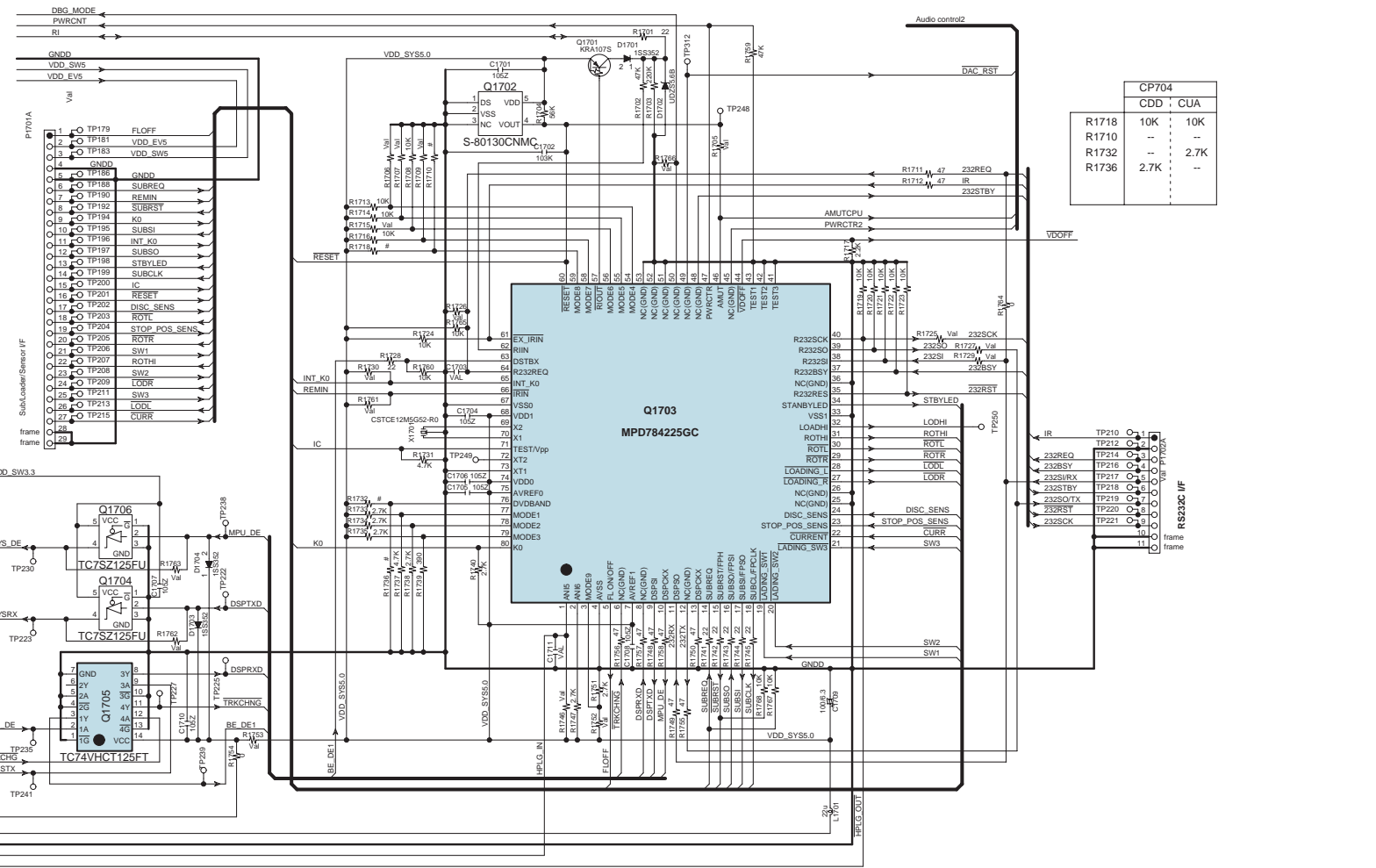
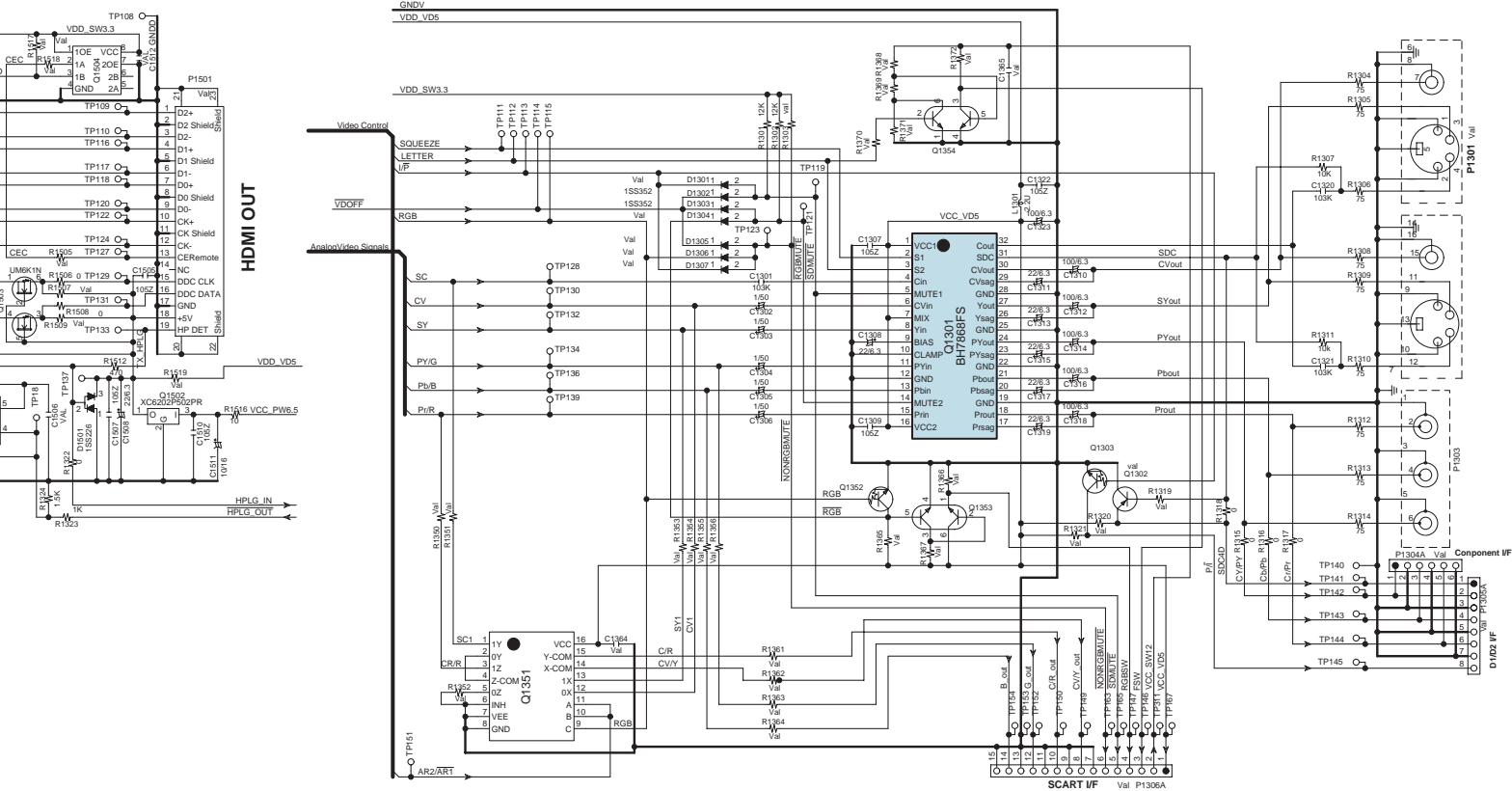

A

B

C

D

# PRINTED CIRCUIT BOARD VIEWS-1

## U01 DVD MAIN circuit PC BOARD (NADG-8875)

Component side

1

2

3

4

5

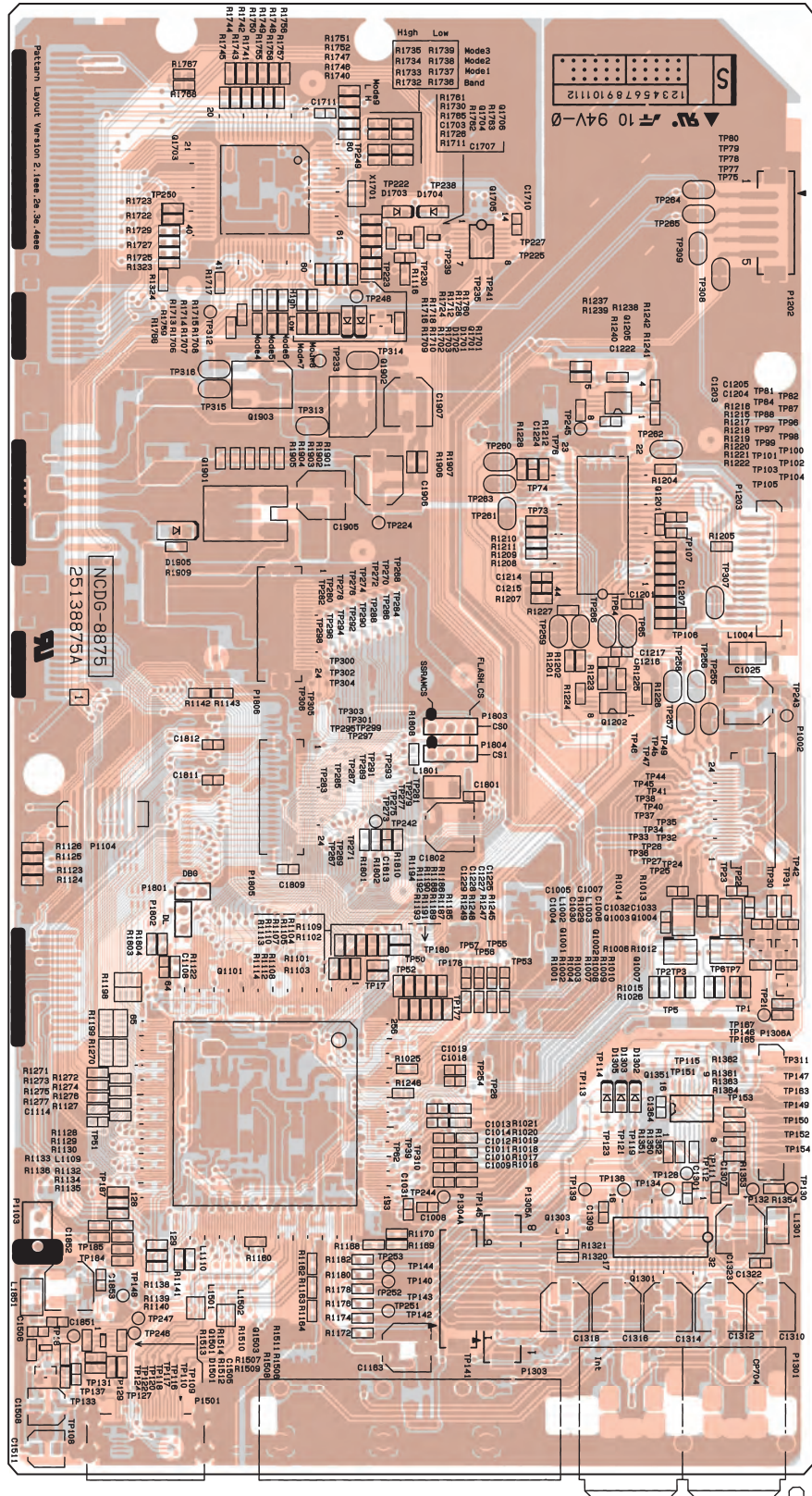

Soldering side

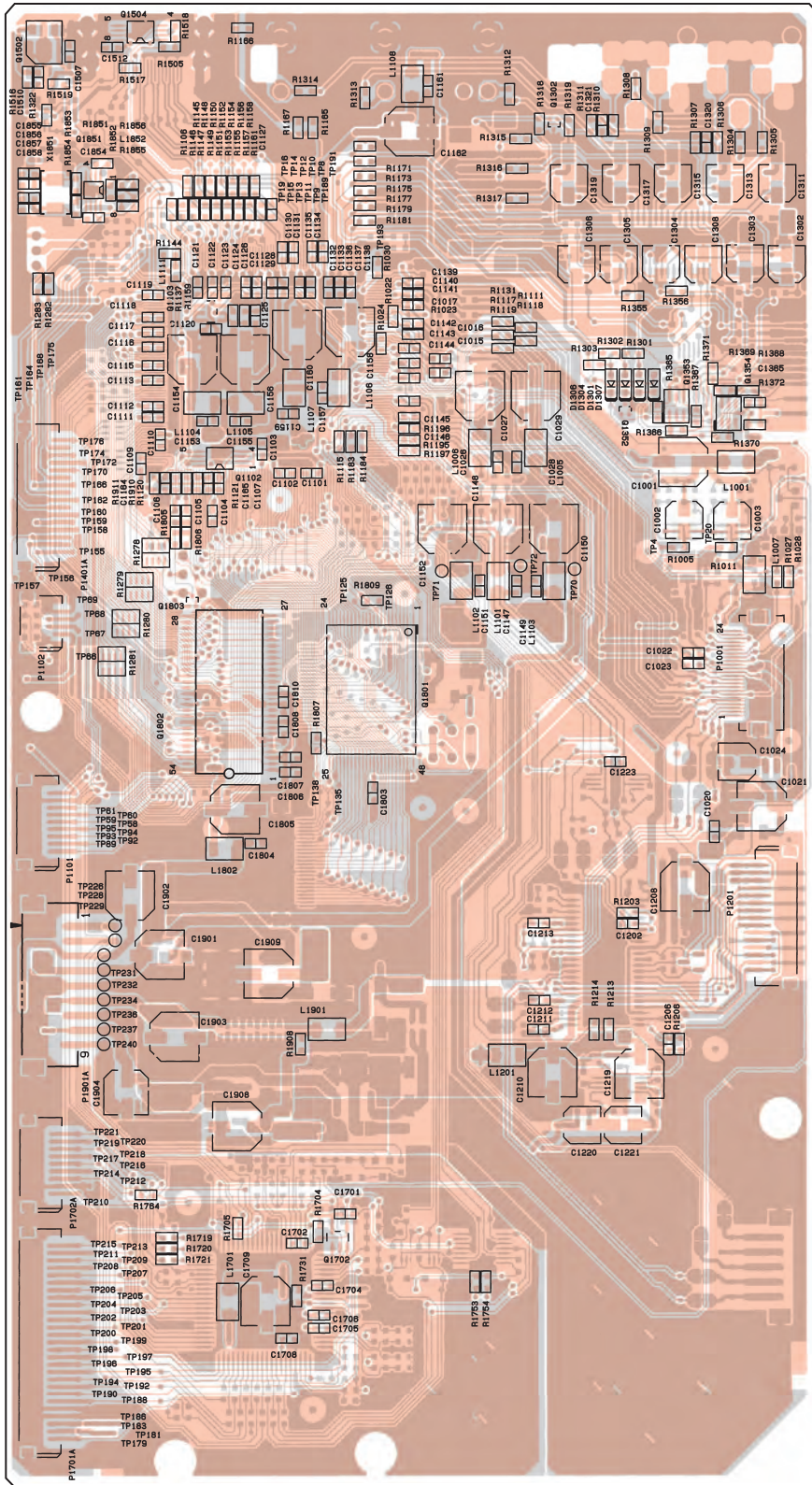

A

B

C

D

# PRINTED CIRCUIT BOARD VIEWS-2

## U002-0 Display circuit PC BOARD (NADIS-8859)

Component side

Soldering side

1

2

3

4

5

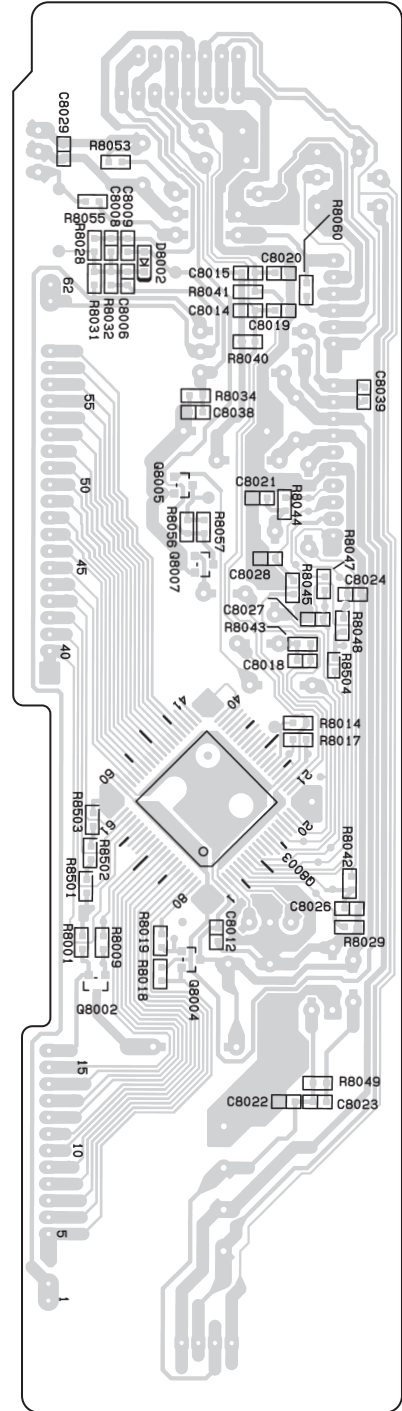
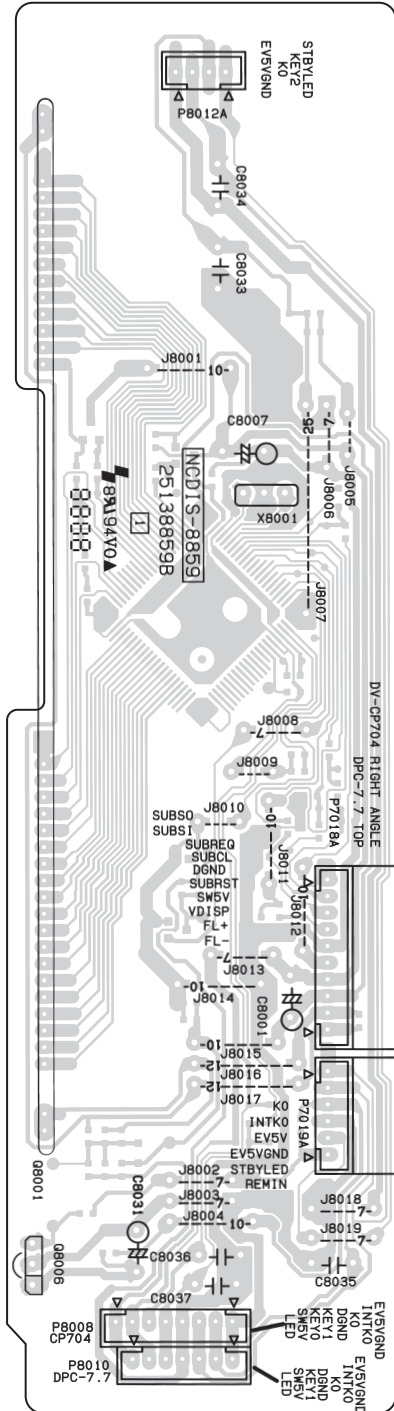

A

B

C

D

# PRINTED CIRCUIT BOARD VIEWS-3

## U002-1 DVD Mecha. Control PC BOARD (NADG-8860)

Component side

1

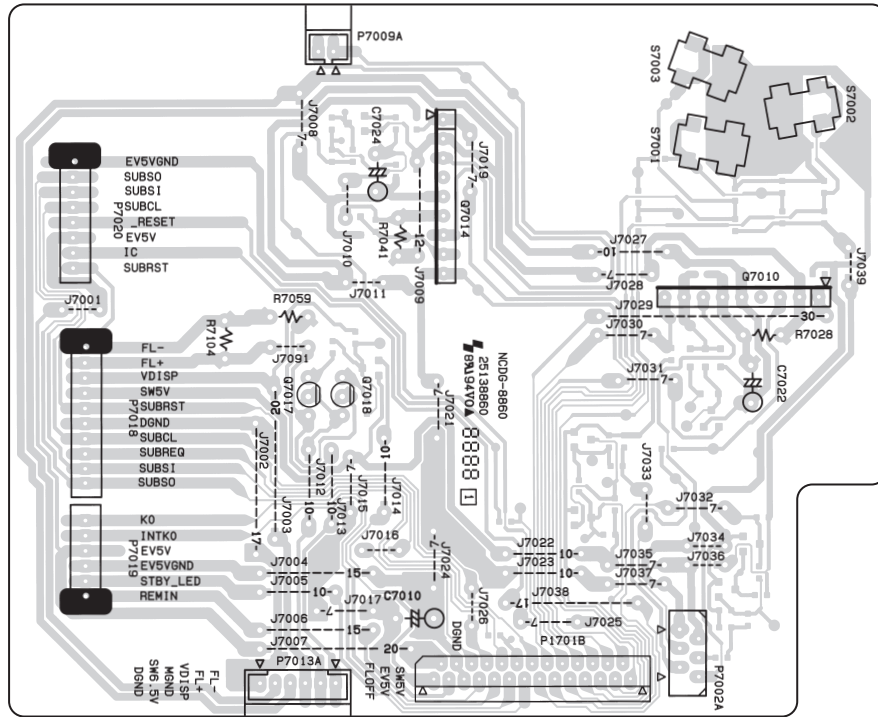

2

3

Soldering side

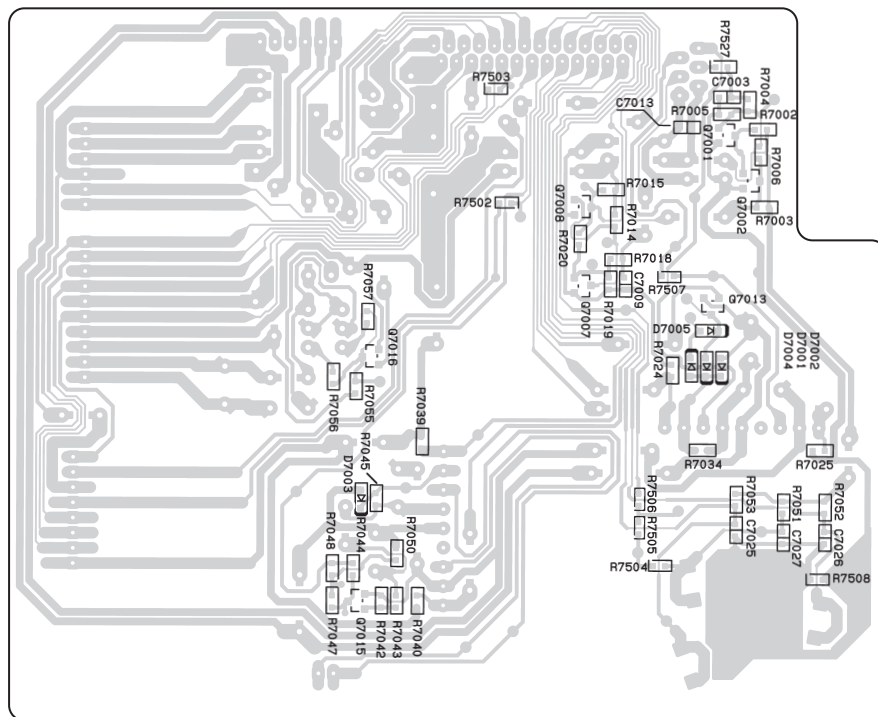

4

5

A

B

C

D

# PRINTED CIRCUIT BOARD VIEWS-4

## U002-2 Audio output terminal PC BOARD (NAAF-8861)

Component side

1

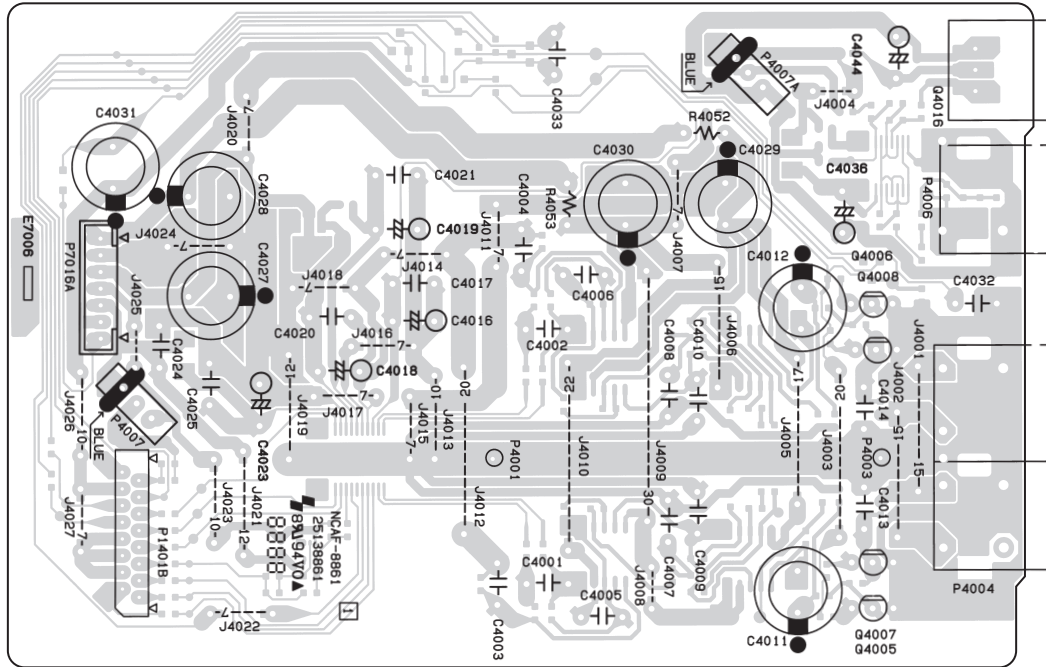

2

3

Soldering side

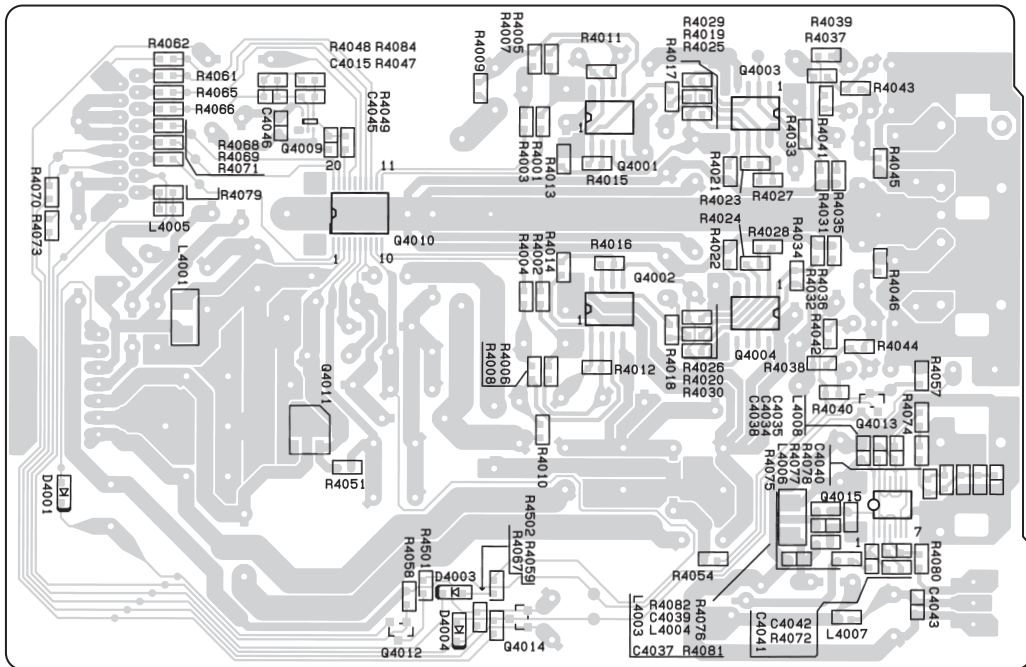

4

5

A

B

C

D

# PRINTED CIRCUIT BOARD VIEWS-5

## U002-3 RS-232C terminal PC BOARD (NADG-8862)

Component side

1

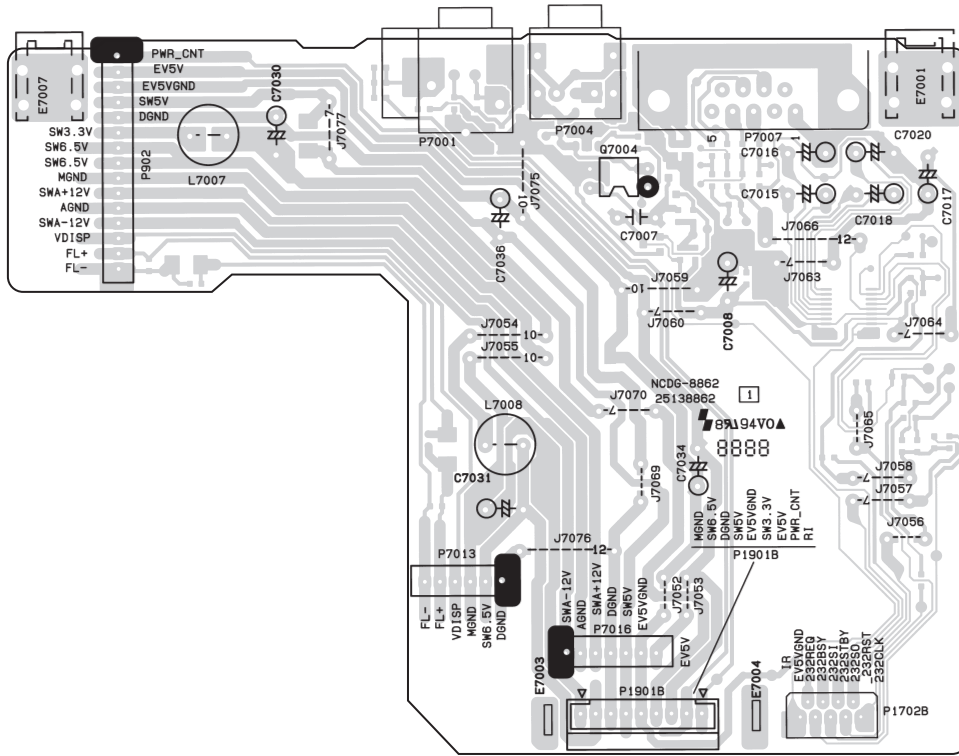

2

3

Soldering side

4

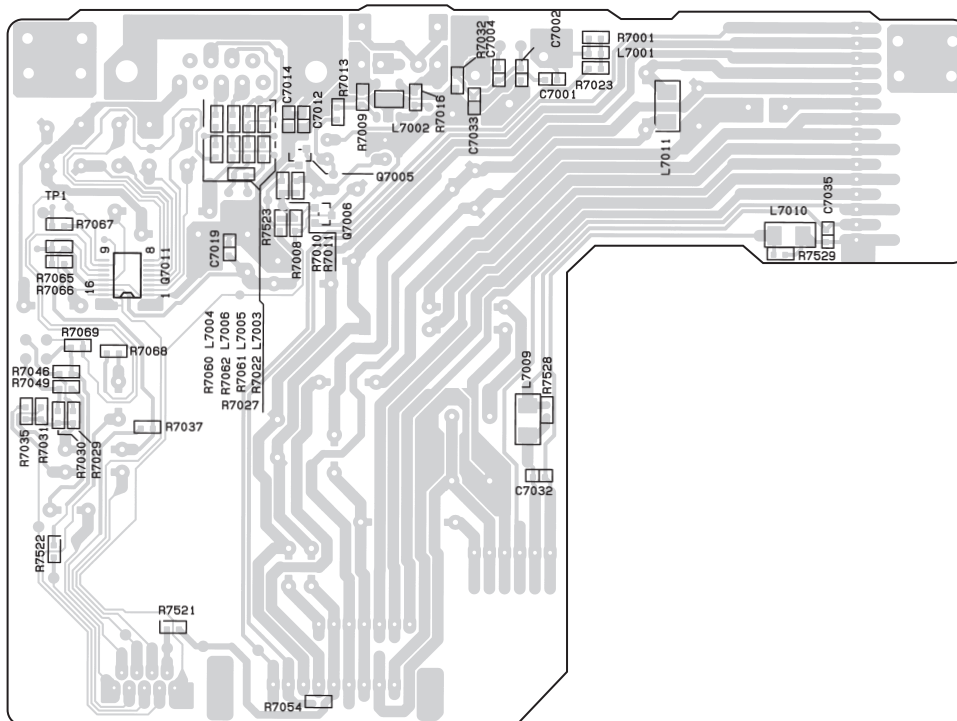

5



A

B

C

D

# PRINTED CIRCUIT BOARD VIEWS-6

## U002-7 Connection PC BOARD (NAETC-8870)

Component side

1

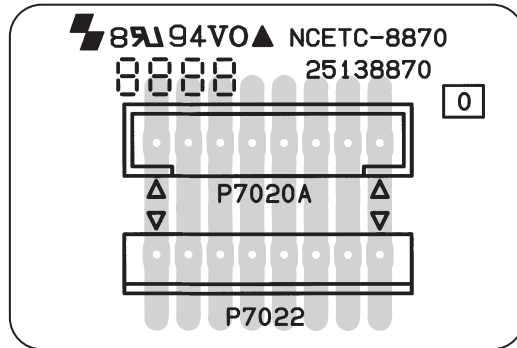

2

3

## U002-4 Standby switch PC BOARD (NASW-8866)

Component side

4

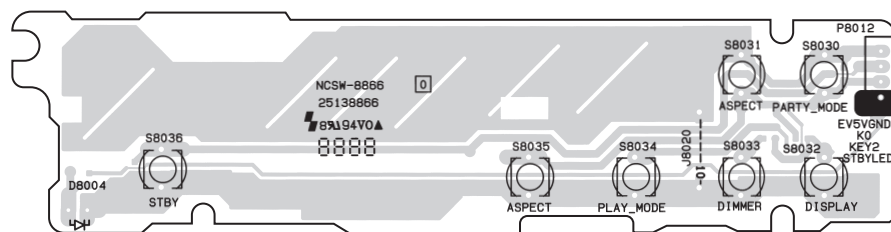

Soldering side

5

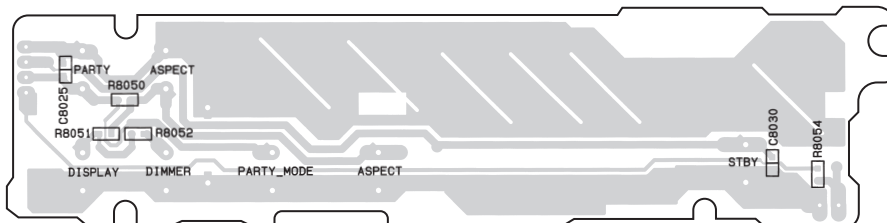

A B C D

PRINTED CIRCUIT BOARD VIEWS-7

**U002-5** Illumination PC BOARD (NADIS-8867)

Component side

1

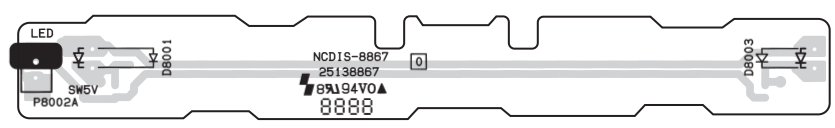

Soldering side

2



**U002-6** Disc sensor PC BOARD (NAETC-8868)

Component side

3

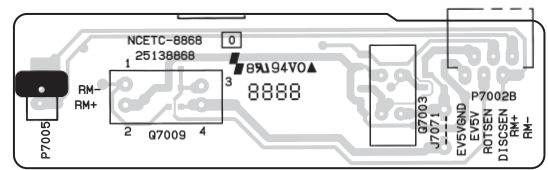

Soldering side

4

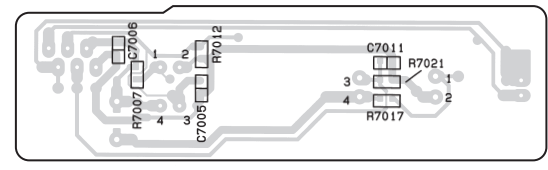

**U02-9** Connection-1 PC BOARD (NAETC-8869)

Component side

5

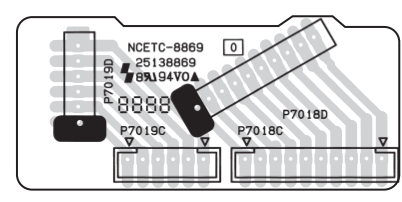

A

B

C

D

PRINTED CIRCUIT BOARD VIEWS-8

**U002-8** Loading motor PC BOARD (NAETC-8872)

1

Component side

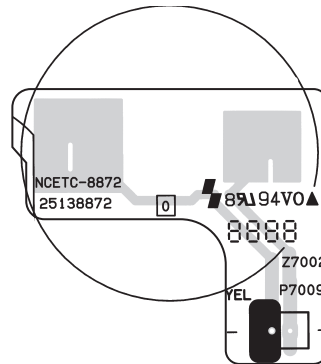

2

Soldering side

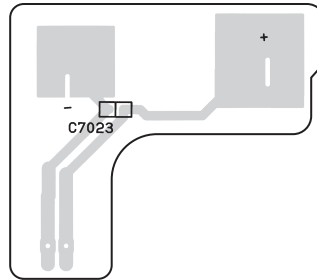

3

**U002-9** Roulette motor PC BOARD (NAETC-8873)

4

Component side

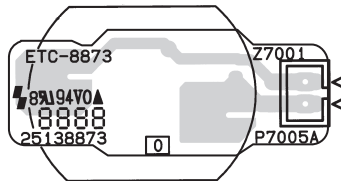

5

Soldering side

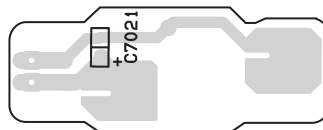

A

B

C

D

# PRINTED CIRCUIT BOARD VIEWS-9

## U002-10 Key operation PC BOARD (NASW-8863)

Component side

Soldering side

1

2

3

4

5

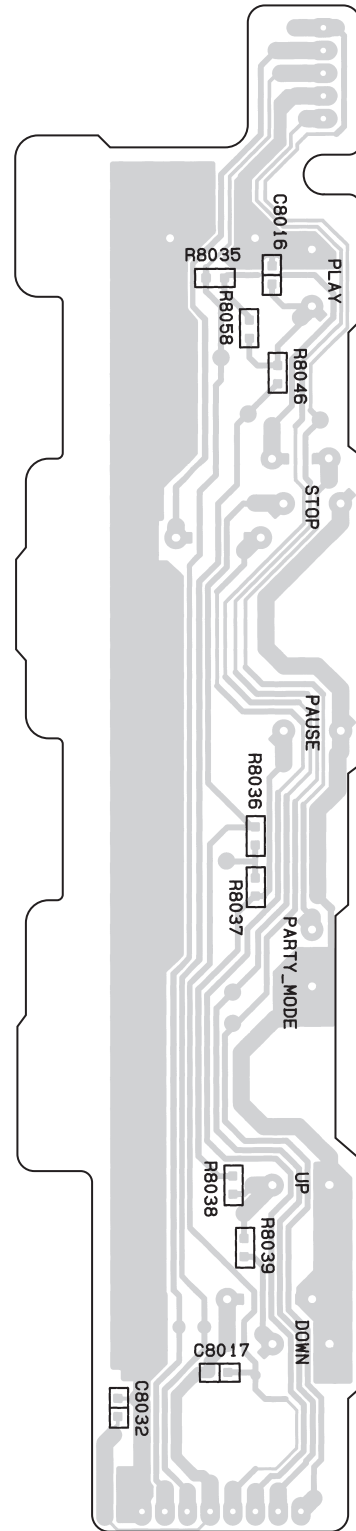
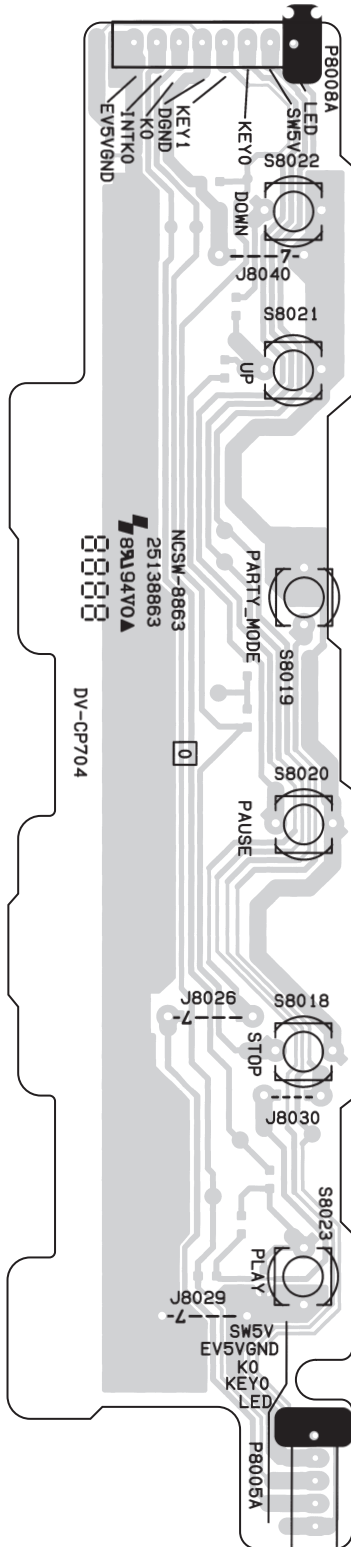

A

B

C

D

# PRINTED CIRCUIT BOARD VIEWS-12

## U002-11 Disc operation PC BOARD (NASW-8864)

Component side

Soldering side

1

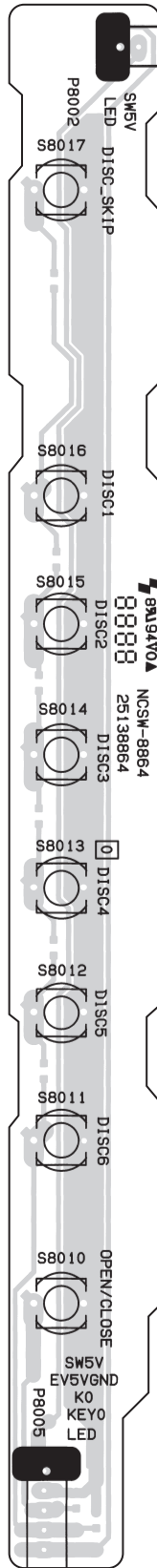

2

3

4

5

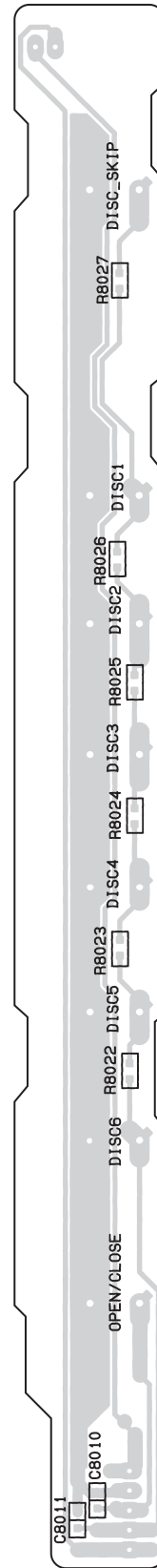

## UPGRADE FW

(1) Prepare a FW disc

The files necessary for DV-CP704 are as follows.

```
multi_m.ver
multi.ver
sardonyx.f16
```

Store these 3 and also about 40MB of files (total, WAVE, MP3 etc.) in a CD-R in "Disc-at-once" mode.

(2) Check Version in advance

Hold down [Display] and then press [Stop] to display Version of System Microprocessor.

Press [Display] twice and see the version shown on OSD.

Make sure that the existing version is shown in "Release Version" column at the top of the list.

Sample: "OE-060725A(H--1-----)"

"H" confirms a HDCP key has been loaded.

The 4th digit from the left "1" shows Region.

In case of "-----" or "H-9-----", the unit needs board replacement.

(3) Write the FW

1. Load the FW disc in Tray 1 to read it.

On the OSD, the following messages are shown.

```
Farm Upgrade
Erase and program
```

```
Start [Cancel]
```

"Cancel" is highlighted as cursor position.

On the front display, "VERUP NO" is shown.

2. Change from "Cancel" to "Start" with Left/Right cursor on Remote Controller or [Left]/[Right] key on the unit.

See "VERUP YES" is shown on the front display.

Press [Enter] on Remote Controller or [Play] on the body to start FW writing.

```
Firmware Upgrade
Programming, please wait...
Do not switch the player off!
```

On the front display, "DISC READ" is shown.

After reading is finished,

"FLASHWRITE" is shown on the front display and then Tray is opened.

Take the FW disc out.

3. The message has gone from the front display and Tray is closed.

This is the end of FW writing.

If the display does not change for 5 minutes, try FW writing (3) again after turning off and on.

4. Confirm Version after FW writing

Power off and on.

Hold down [Display] and then press [Stop] to show Version of System Microprocessor.

Press [Display] twice and see the version shown on the OSD.

Make sure that the correct version is shown in "Release Version" column at the top of the list.

Sample: "OE-060725B(H--1-----)"

"H" confirms a HDCP key has been loaded.

The 4th digit from the left "1" shows Region.

In case of "-----" or "H-9-----", the unit needs board replacement.

## OPERATION GUIDE

### ★ Initialization

1. Press the "STOP" & "STANDBY" at the same with NO DISC condition.
2. Will display "COMPLETE" on FL tube after initializing for setting & mechanism.

The unit will be going to "STANDBY" after display "COMPLETE".

\*All of the setting(VIDEO, AUDIO & etc.) will be initialized.

Please refer the "Default Setting" for each destination.

### ★ Destination setting

	R1732	R1736	R1710	R1718	Destination	Region Code	TV mode
CDD1N	OPEN	2.7Kohm	OPEN	10Kohm	North America	1	NTSC
CUA4P	2.7Kohm	OPEN	OPEN	10Kohm	Australia	4	PAL / AUTO

### ★ Region cord check

Press Dimmer key and Pause key at the same time , after release press pause key again.

Display REGION CORD on FL.

**CDD1N : USA 1 NTSC**

**CPA4P : AUS 4 PAL**

### ★ Test mode

1. Press the "STOP" & "DISPLAY" at the same with NO DISC condition.  
Current version number of sub-micon is displayed on the FL tube.
2. Press the "DISPLAY".  
Current version number of BACK END micon is displayed on the FL tube.
- 3 Press the "DISPLAY".  
All segment of FL tube light up.
4. Press the "DISPLAY".  
Will be displayed "DISPLAY KEY" on FL tube.  
Press any keys except "STANDBY".  
The function name of pressed key is display on the FL tube.  
Press each key and confirm that the name of pressed key.
5. Press "STANDBY" to exit the test mode.

# PACKING PROCEDURES

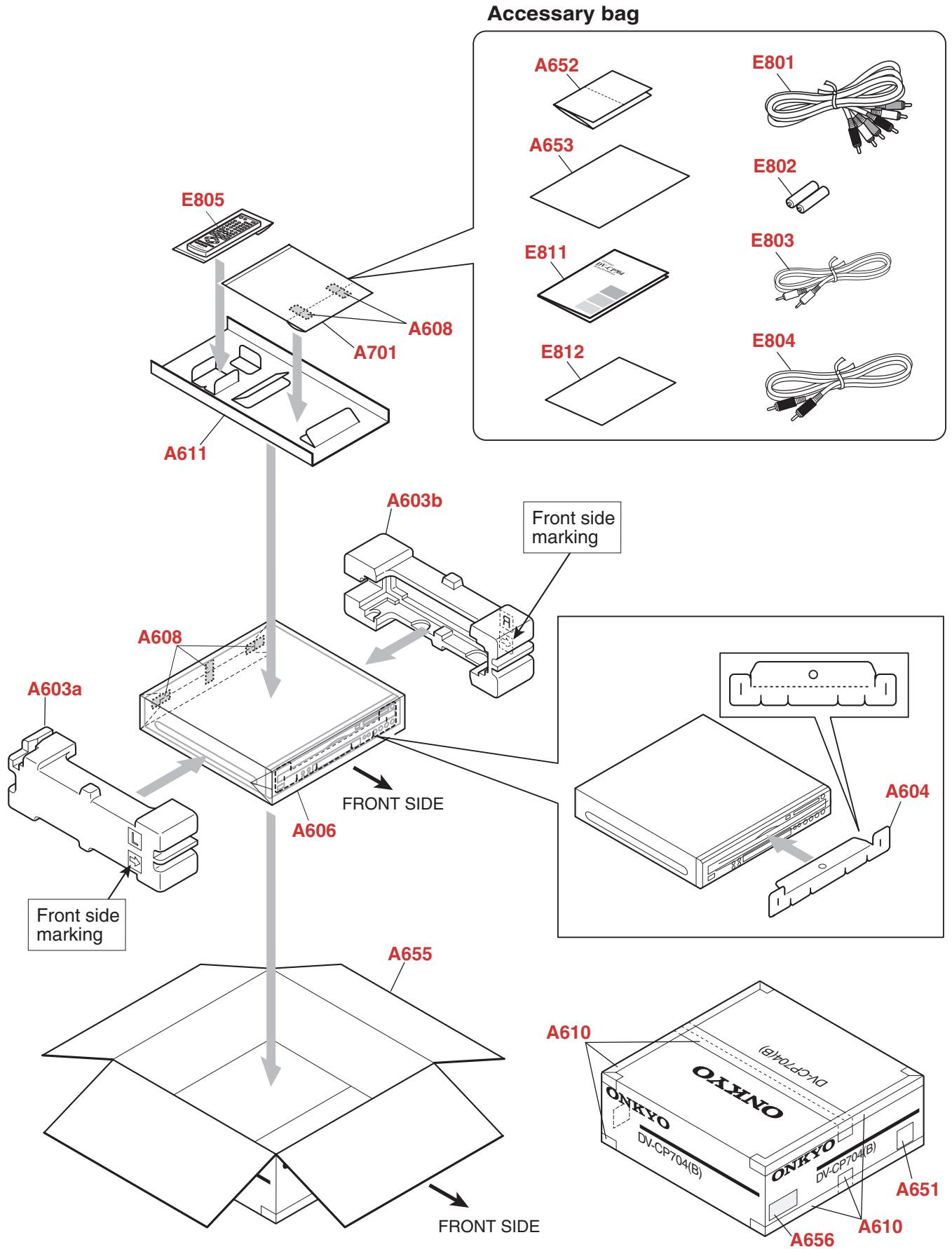



**ONKYO CORPORATION**

Sales & Product Planning Div. : 2-1, Nisshin-cho, Neyagawa-shi, OSAKA 572-8540, JAPAN  
Tel: 072-831-8023 Fax: 072-831-8124

**ONKYO U.S.A. CORPORATION**

18 Park Way, Upper Saddle River, N.J. 07458, U.S.A.  
Tel: 201-785-2600 Fax: 201-785-2650 <http://www.us.onkyo.com/>

**ONKYO EUROPE ELECTRONICS GmbH**

Liegnitzerstrasse 6, 82194 Groebenzell, GERMANY  
Tel: +49-8142-4401-0 Fax: +49-8142-4401-555 <http://www.eu.onkyo.com/>

**ONKYO EUROPE UK Office**

Suite 1, Gregories Court, Gregories Road, Beaconsfield, Buckinghamshire, HP9 1HQ  
UNITED KINGDOM Tel: +44-(0)1494-681515 Fax: +44(0)-1494-680452

**ONKYO CHINA LIMITED**

Units 2102-2107, Metroplaza Tower I, 223 Hing Fong Road, Kwai Chung,  
N.T., HONG KONG Tel: 852-2429-3118 Fax: 852-2428-9039  
<http://www.ch.onkyo.com/>



## PARTS LIST

DV-CP704

1/20 PAGE

## EXPLODED VIEW PARTS LIST

N: New parts

NSP: Not service parts

!: Safety parts

	REF. NO.	PART NAME	DESCRIPTION	PART NO.	REMARKS	
EXP	A001	F PANEL	DV-CP704(B)	1466-1807+0	<B> N	1
EXP	A001	F PANEL	DV-CP704(S)	1466-1808+0	<S> N	1
EXP	A002	KNOB	(STBY)	2446-3901+0	<B>	1
EXP	A002	KNOB	(STBY)	2446-3703+0	<S>	1
EXP	A003	KNOB	(SEL)	2446-4101+0	<B>	1
EXP	A003	KNOB	(SELL)	2446-3803+0	<S>	1
EXP	A004	KNOB	(EJ)	2446-4601+0	<B>	1
EXP	A004	KNOB	(EJ)	2446-4403+0	<S>	1
EXP	A005	KNOB	(PLAY)	2446-4301+0	<B>	1
EXP	A005	KNOB	(PLAY)	2446-4003+0	<S>	1
EXP	A006	KNOB	(DIS)	2446-4501+0	<B>	1
EXP	A006	KNOB	(DIS)	2446-4203+0	<S>	1
EXP	A007	RETAINER	(BDG)	4135-3701+0		1
EXP	A008	BADGE	BADGE	4154-6151+0-*	<B>	1
EXP	A008	BADGE	--	4154-6212+0-*	<S>	1
EXP	A011	CLEAR PLT	--	3717-1012+0	<B> N	1
EXP	A011	CLEAR PLT	--	3717-1013+0	<S> N	1
EXP	A013	FACET	(LIGHT)	3716-8306+0		1
EXP	A014	FACET	(B)(S)	3716-8511+0		1
EXP	A016	TAPE	CLOTH-8U	1635-0110+0	5cm	1
EXP	A017	DAMPER	--	4149-0582+0-*	FL x 2	1
EXP	A018	BRACKET	(F)	4135-3181+1		1
EXP	A019	SCREW	2.6TTB+8B(3BC)	2954-2608+3000		14
EXP	A021	ISO PLT	--	4154-6191+0		1
EXP	A022	P RIVET	P-3055B-8L	4154-5341+0		2
EXP	A025	SCREW	3TTB+8B(3CM)	2954-3008+0000		2
EXP	A026	SCREW	3TTW+8B(3BC)	2954-3008+3010	For F Panel	3
EXP	A027	SCREW	3P+6FN(3BC)	2900-3006+3000	PCB x 2	2
EXP	A028	SPACER	φ 8*M3*0.8t	2601+3008+0801	N	2
EXP	A030	CHASSIS	--	1406-2101+0	N	1
EXP	A031	HOLDER	KGLS-10RT	4154-5291+0		2
EXP	A032	HOLDER	KGLS-8RT	4154-4561+0-*		2
EXP	A033	HOLDER	HOLDER KGLS-18S	4154-6561+0-*		1
EXP	A034	HOLDER	KGPS-8RF	4155-2161+0		1
EXP	A035	TAPE	TAPE(CLOTH-16U)	9500-9007+0		1
EXP	A036	WIRE TIE	BSK-1	6360-9570+0		4
EXP	A037	DAMPER	--	4149-0582+0-*	PCB x 1	1
EXP	A040	SCREW	3TTW+8B(3BC)	2954-3008+3000	MECHAx8	8
EXP	A041	BOTTOM LEG	--	4155-2081+0	N	2
EXP	A042	CUSHION	--	4149-1011+0		2
EXP	A044	SCREW	3TTB+8B(3CM)	2954-3008+0000		2
EXP	A045	CUSHION	7.5x14x1.5	4149-1001+0		2
EXP	A048	BUSHING	S-RELIEF #2271	4154-4161+0-*	!	1
EXP	A050	DOOR	(TRAY)	4154-6121+2	<B>	1
EXP	A050	DOOR	(TRAY)	4154-6124+2	<S>	1
EXP	A051	DAMPER	--	4149-0582+0-*		1
EXP	A053	REAR PANEL	DV-CP704CDD	1406-0701+0	<B/S CDD> N	1
EXP	A053	REAR PANEL	DV-CP704CUA	1406-0702+0	<B/S CUA> N	1
EXP	A054	SCREW	3TTB+8B(3BC)	2954-3008+3000		12
EXP	A055	SCREW	3P+6FN(3BC)	2900-3006+3000		1
EXP	A056	LABEL(DVD2)	--	3000-9443+0		1

EXP	A214	COVER	DV-CP704(B)	1404-7411+0	<B> N	1
EXP	A214	COVER	DV-CP704(S)	1404-7412+0	<S> N	2/20 PAGE
EXP	A215	SCREW	3TTB+8B(3BC)	2954-3008+3000	<B> For top cover	8
EXP	A215	SCREW	3TTB+8B(3CM)	2954-3008+0000	<S> For top cover	8
EXP	A216	SHEET	(B)(S)	3000-9632+0		1
EXP	F901	FUSE	2A-UL/T-233	5120-1107+0	<CDD> !	1
EXP	F901	FUSE	2A-SE-EAK FUSE	5120-0150+1	<CUA> N !	1
EXP	P1002	FFC	NCFCC-242012	7012-8170+0	N	1
EXP	P1401	FFC	NCF5-162512	7012-8200+0		1
EXP	P1701	FFC	NCF5-272012	7012-8180+0	N	1
EXP	P1901	SOCKET AS	NSAS-18P1605	7012-8160+0	N	1
EXP	P7002	FFC	NCF3-06024	7012-8250+0	N	1
EXP	P902	AC CORD	AS-UC-2	7012-8220+0	! <CDD> N	1
EXP	P902 or	AC CORD	AS-UC-2		! <CDD> N	(1)
EXP	P902 or	AC CORD	AS-UC-2		! <CDD> N	(1)
EXP	P902	AC CORD	AS-SAA	7012-8230+0	! <CUA> N	1
EXP	P902 or	AC CORD	AS-SAA		! <CUA> N	(1)
EXP	P902 or	AC CORD	AS-SAA		! <CUA> N	(1)
EXP	Q1101A	HEAT SINK	HH-AA-B-P	5400-9781+0	N	1
EXP	Z001	DVD Mecha. Assy	NDV-100TE-C	4111-1153+0		1
EXP	U001	DVD Main circuit PC board assy	NADG-8875-1A	SVC-DV70414+MAIA	<CDD> N	1
EXP	U001	DVD Main circuit PC board assy	NADG-8875-1B	SVC-DV70414+MAIB	<CUA> N	1
EXP	U002	Display circuit PC board assy	NADIS-8859-1A	SVC-DV70414+DIS	N, NSP	1
EXP	U002-0	Display circuit PC board assy	NADIS-8859-1A	1H538559-1A	N, Onkyo Part number	1
EXP	U002-1	DVD Mecha. control PC board assy	NADG-8860-1A	1H538560-1A	N, Onkyo Part number	1
EXP	U002-2	Audio output PC board assy	NAAF-8861-1A	1H538561-1A	N, Onkyo Part number	1
EXP	U002-3	RS-232C terminal PC board assy	NADG-8862-1A	1H538562-1A	N, Onkyo Part number	1
EXP	U002-4	Standby switch PC board assy	NASW-8866-1A	1H538566-1A	N, Onkyo Part number	1
EXP	U002-5	Illumination PC board assy	NADIS-8867-1A	1H538567-1A	N, Onkyo Part number	1
EXP	U002-6	Disc sensor PC board assy	NAETC-8868-1A	1H538568-1A	N, Onkyo Part number, NSP	1
EXP	U002-8	Loadin motor PC board assy	NAETC-8872-1A	1H538572-1A	N, Onkyo Part number, NSP	1
EXP	U002-9	Roulette motor PC board assy	NAETC-8873-1A	1H538573-1A	N, Onkyo Part number, NSP	1
EXP	U002-10	Key operation PC board assy	NASW-8863-1A	1H538563-1A	N, Onkyo Part number	1
EXP	U002-11	Disc operation PC board assy	NASW-8864-1A	1H538564-1A	N, Onkyo Part number	1
EXP	U003	Power supply unit	NGPS-0074-100-120V	8902-0013+0	<CDD> N	1
EXP	U003	Power supply unit	NGPS-0075-100-240V	8902-0014+0	<CUA> N	1
EXP	F102	Quick Acting Micro Fuse	MQ2A/125V	OP66	N !	
EXP	F105	Quick Acting Micro Fuse	MQ3A/125V	OP67	N !	

### PACKING VIEW PARTS LIST

DV-CP704

REF. NO.	PART NAME	DESCRIPTION	GPE PART NO.	REMARKS	
PKG	A603	PAD	AS	--	1
PKG	A603a	PAD( L )		1490-4401+0	1
PKG	A603b	PAD( R )		1490-4411+0	1
PKG	A604	SHEET	(DR)	4154-6221+0	1
PKG	A606	BAG	-	1497-7542+1	N
PKG	A608	TAPE	NITTO NO.29	9500-9012+0	1
PKG	A610	PP TAPE	W48 OPP TAPE	9500-9010+0	1
PKG	A611	SHEET	(PAD)	1450-9290+0	N
PKG	A651	UPC LABEL	DV-CP704(B)	3001-1483+0	<B CDD> N
PKG	A651	EAN LABEL	DV-CP704(B)	3001-1484+0	<B CUA> N
PKG	A651	UPC LABEL	DV-CP704(S)	3001-1484+0	<S CDD> N
PKG	A651	EAN LABEL	DV-CP704(S)	3001-1486+0	<S CUA> N
PKG	A653	INST SHEET	(PAC)	3050-2521+0	1
PKG	A655	CARTON	DV-CP704(B)CDD	1436-2913+0-2	<B> N
PKG	A655	CARTON	DV-CP704(S)CDD	1436-2914+0-2	<S> N
PKG	A656	LABEL	CUA4P	3001-1481+0	<CUA> only N

PKG	A701	POLY BAG	350*250	1497-7382+0		1
PKG	E801	PIN CORD AS	RCA3P(YWR)	7012-6531+0		3/20 PAGE
PKG	E801 or	PIN CORD AS	RCA-3P(YWR)			(1)
PKG	E802	BATTERY	R6/AA(UM-3)	4060-0930+0-*		2
PKG	E802 or	BATTERY	R6/AA(UM-3)			(2)
PKG	E803	PLUG CORD	3.5-MINI PLUG (RI)	7012-6539+0-*		1
PKG	E804	CORD AS	RCA-1P(O)	7012-6694+0		1
PKG	E805	REMO CON	RC-655DV	8912-0053+0	N	1
PKG	E811	INS MANUAL	En(DVCP704)	4301-7246+0	N	1
PKG	E812	INS MANUAL	En(DVCP704)HDMI	4301-7245+0		1

### DV-CP704

### CHANGER MECHANISM EXPLODED VIEW PARTS LIST

REF. NO.	PART NAME	DESCRIPTION	PART NO.	REMARKS	
MECH. M001	RAIL	--	4155-2052+0	N	1
MECH. M002	<b>Loading Motor assy</b>		<b>SVC-Q0090C-MOT1</b>		
MECH. M004	SCREW	2.6TTP+4S(3CM)	2900-2604+0000		2
MECH. M005	Rubber Belt	DVCP701	4157-0281+0		1
MECH. M006	GEAR	(PULLEY)	4154-6061+0		1
MECH. M007	GEAR	(A)	4154-6091+0		1
MECH. M008	GEAR	(MAIN)	<b>4154-6071+2</b>		1
MECH. M009	GEAR	(CAM)	4154-6101+0		1
MECH. M010	SCREW	3*8*w11	4135-3301+0-*	N	3
MECH. M011	HOLDER	KGLS-8RT	4154-4561+0-*		3
MECH. M012	DVD Mecha.	TDT-2100SF-0	4111-1153+0	N	1
MECH. M012a	DAMPER-IDLE	C2G083	24818063	N	{ 4 }
MECH. M012b	SCW-DAMPER-CR3	C1H012	801638	N	{ 4 }
MECH. M012c	CLAMPER-H	A7G202	24824031	N	{ 1 }
MECH. M012d	CLUMPER-L	A7G203	24824032	N	{ 1 }
MECH. M012e	CLAMP-T-M12H	A7P085	24830031	N	{ 1 }
MECH. M013	CHASSIS	(SUB)	1467-7301+0	N	1
MECH. M014	SCREW	3TTB+8B(3CM)	2954-3008+0000		9
MECH. M015	CLIP	CS-1U	4135-3291+0		1
MECH. M030	ARM	--	4155-2061+0	N	1
MECH. M031	CUSHION	--	4157-0532+0		1
MECH. M050	TRAY	--	4154-6011+7		1
MECH. M051	CUSHION	--	4156-0532+0		1
MECH. M052	<b>Bracket assy</b>	(M)	<b>8901-4650+1</b>		1
MECH. M057	GEAR	(WHEEL)	4154-5991+0		1
MECH. M058	WASHER	(B)	4154-4491+0		1
MECH. M053	<b>Roulette Motor assy</b>		<b>SVC-Q0090C-MOT3</b>		
MECH. M056	SCREW	2P+3FN(3CM)	2900-2003+0000	N	2
MECH. M060	ROLLER	DVCP701	4154-6131+0		4
MECH. M061	ROULETTE	--	4155-2042+0	N	1
MECH. M062	SCREW	3*8*w11	4135-3301+0-*	N	1

### PRINTED CIRCUIT BOARD PARTS LIST

### DV-CP704

**U001 : DVD MAIN CIRCUIT PC BOARD NADG-8875-1A <CDD1N>**

**U001 : DVD MAIN CIRCUIT PC BOARD NADG-8875-1B <CUA4P>**

PCB CIRCUIT	PART NAME	DESCRIPTION	GPE PART NO.	REMARKS	
DG887:	C1001	CHIP ELECT C	CEWX4V-220M		1
DG887:	C1002	CHIP ELECT C	CEWX4V-47M		1
DG887:	C1003	CHIP ELECT C	CEWX4V-47M		1
DG887:	C1004	C-CERA C	CK725F1A-105Z1		1
DG887:	C1005	C-CERA C	CK725F1A-105Z1		1

DG887: C1006	C-CERA C	CK725F1A-105Z1	1
DG887: C1007	C-CERA C	CK725F1A-105Z1	4/20 PAGE
DG887: C1008	C-CERA C	CC725CH1H-102J1	1
DG887: C1009	C-CERA C	CC725CH1H-330J1	1
DG887: C1010	C-CERA C	CC725CH1H-330J1	1
DG887: C1011	C-CERA C	CC725CH1H-330J1	1
DG887: C1012	C-CERA C	CC725CH1H-330J1	1
DG887: C1015	C-CERA C	CC725CH1H-330J1	1
DG887: C1016	C-CERA C	CC725CH1H-330J1	1
DG887: C1017	C-CERA C	CK725B1C-104K1	1
DG887: C1018	C-CERA C	CC725CH1H-330J1	1
DG887: C1019	C-CERA C	CC725CH1H-330J1	1
DG887: C1020	C-CERA C	CK725F1A-105Z1	1
DG887: C1021	CHIP ELECT C	CEWX6.3V-100M	1
DG887: C1022	C-CERA C	CK725F1A-105Z1	1
DG887: C1023	C-CERA C	CK725F1A-105Z1	1
DG887: C1024	CHIP ELECT C	CEWX50V-1M	1
DG887: C1025	CHIP ELECT C	CEWX6.3V-100M	1
DG887: C1026	C-CERA C	CK725F1A-105Z1	1
DG887: C1027	CHIP ELECT C	CEWX4V-220M	1
DG887: C1028	C-CERA C	CK725F1A-105Z1	1
DG887: C1029	CHIP ELECT C	CEWX4V-220M	1
DG887: C1031	C-CERA C	CC725CH1H-102J1	1
DG887: C1032	C-CERA C	CK725B1C-104K1	1
DG887: C1033	C-CERA C	CK725B1C-104K1	1
DG887: C1101	C-CERA C	CK725F1A-105Z1	1
DG887: C1102	C-CERA C	CK725F1A-105Z1	1
DG887: C1103	C-CERA C	CK725F1A-105Z1	1
DG887: C1104	C-CERA C	CK725F1A-105Z1	1
DG887: C1105	C-CERA C	CK725F1A-105Z1	1
DG887: C1106	C-CERA C	CK725F1A-105Z1	1
DG887: C1107	C-CERA C	CK725F1A-105Z1	1
DG887: C1108	C-CERA C	CC725CH1H-330J1	1
DG887: C1109	C-CERA C	CK725F1A-105Z1	1
DG887: C1110	C-CERA C	CK725F1A-105Z1	1
DG887: C1111	C-CERA C	CK725F1A-105Z1	1
DG887: C1112	C-CERA C	CK725F1A-105Z1	1
DG887: C1113	C-CERA C	CK725F1A-105Z1	1
DG887: C1114	C-CERA C	CC725CH1H-050C1	1
DG887: C1115	C-CERA C	CK725F1A-105Z1	1
DG887: C1116	C-CERA C	CK725F1A-105Z1	1
DG887: C1117	C-CERA C	CK725F1A-105Z1	1
DG887: C1118	C-CERA C	CK725F1A-105Z1	1
DG887: C1119	C-CERA C	CK725F1A-105Z1	1
DG887: C1120	C-CERA C	CK725F1A-105Z1	1
DG887: C1121	C-CERA C	CK725F1A-105Z1	1
DG887: C1122	C-CERA C	CK725F1A-105Z1	1
DG887: C1123	C-CERA C	CK725F1A-105Z1	1
DG887: C1124	C-CERA C	CK725F1A-105Z1	1
DG887: C1125	C-CERA C	CC725CH1H-102J1	1
DG887: C1126	C-CERA C	CK725F1A-105Z1	1
DG887: C1128	C-CERA C	CK725F1A-105Z1	1
DG887: C1129	C-CERA C	CC725CH1H-101J1	1
DG887: C1130	C-CERA C	CK725F1A-105Z1	1
DG887: C1131	C-CERA C	CC725CH1H-101J1	1
DG887: C1132	C-CERA C	CK725F1A-105Z1	1
DG887: C1133	C-CERA C	CC725CH1H-101J1	1

DG887: C1134	C-CERA C	CK725F1A-105Z1	1
DG887: C1135	C-CERA C	CC725CH1H-101J1	5/20 PAGE
DG887: C1136	C-CERA C	CK725F1A-105Z1	1
DG887: C1137	C-CERA C	CK725F1A-105Z1	1
DG887: C1138	C-CERA C	CK725F1A-105Z1	1
DG887: C1139	C-CERA C	CK725F1A-105Z1	1
DG887: C1140	C-CERA C	CK725F1A-105Z1	1
DG887: C1141	C-CERA C	CK725F1A-105Z1	1
DG887: C1142	C-CERA C	CK725F1A-105Z1	1
DG887: C1143	C-CERA C	CK725F1A-105Z1	1
DG887: C1144	C-CERA C	CK725F1A-105Z1	1
DG887: C1145	C-CERA C	CK725F1A-105Z1	1
DG887: C1146	C-CERA C	CK725F1A-105Z1	1
DG887: C1147	C-CERA C	CK725F1A-105Z1	1
DG887: C1148	CHIP ELECT C	CEWX4V-220M	1
DG887: C1149	C-CERA C	CK725F1A-105Z1	1
DG887: C1150	CHIP ELECT C	CEWX4V-220M	1
DG887: C1151	C-CERA C	CK725F1A-105Z1	1
DG887: C1152	CHIP ELECT C	CEWX4V-220M	1
DG887: C1153	C-CERA C	CK725F1A-105Z1	1
DG887: C1154	CHIP ELECT C	CEWX4V-220M	1
DG887: C1155	C-CERA C	CK725F1A-105Z1	1
DG887: C1156	CHIP ELECT C	CEWX4V-220M	1
DG887: C1157	C-CERA C	CK725F1A-105Z1	1
DG887: C1158	CHIP ELECT C	CEWX4V-220M	1
DG887: C1159	C-CERA C	CK725F1A-105Z1	1
DG887: C1160	CHIP ELECT C	CEWX4V-220M	1
DG887: C1161	C-CERA C	CK725F1A-105Z1	1
DG887: C1162	CHIP ELECT C	CEWX4V-220M	1
DG887: C1163	CHIP ELECT C	CEWX4V-220M	1
DG887: C1164	C-CERA C	CC725CH1H-220J1	1
DG887: C1165	C-CERA C	CC725CH1H-220J1	1
DG887: C1201	C-CERA C	CK725F1H-104Z1	1
DG887: C1202	C-CERA C	CC725CH1H-101J1	1
DG887: C1203	C-CERA C	CK725B1H-103K1	1
DG887: C1204	C-CERA C	CK725B1H-103K1	1
DG887: C1205	C-CERA C	CK725B1H-103K1	1
DG887: C1206	C-CERA C	CC725CH1H-102J1	1
DG887: C1207	C-CERA C	CK725F1H-104Z1	1
DG887: C1208	CHIP ELECT C	CEWX16V-100M	1
DG887: C1210	CHIP ELECT C	CEWX6.3V-100M	1
DG887: C1211	C-CERA C	CK725F1A-105Z1	1
DG887: C1212	C-CERA C	CK725F1A-105Z1	1
DG887: C1213	C-CERA C	CK725F1A-105Z1	1
DG887: C1214	C-CERA C	CK725B1C-104K1	1
DG887: C1215	C-CERA C	CC725CH1H-101J1	1
DG887: C1219	CHIP ELECT C	CEWX4V-220M	1
DG887: C1220	CHIP ELECT C	CEWX4V-47M	1
DG887: C1221	CHIP ELECT C	CEWX4V-47M	1
DG887: C1222	C-CERA C	CK725F1A-105Z1	1
DG887: C1223	C-CERA C	CK725F1A-105Z1	1
DG887: C1224	C-CERA C	CK725B1H-103K1	1
DG887: C1225	C-CERA C	CC725CH1H-102J1	1
DG887: C1227	C-CERA C	CK725B1E-223K1	1
DG887: C1228	C-CERA C	CK725B1E-223K1	1
DG887: C1229	C-CERA C	CC725CH1H-102J1	1
DG887: C1301	C-CERA C	CK725B1H-103K1	1

DG887: C1302	CHIP ELECT C	CEWX50V-1M	1
DG887: C1303	CHIP ELECT C	CEWX50V-1M	6/20 PAGE
DG887: C1304	CHIP ELECT C	CEWX50V-1M	1
DG887: C1305	CHIP ELECT C	CEWX50V-1M	1
DG887: C1306	CHIP ELECT C	CEWX50V-1M	1
DG887: C1307	C-CERA C	CK725F1A-105Z1	1
DG887: C1308	CHIP ELECT C	CEWX6.3V-22M	1
DG887: C1309	C-CERA C	CK725F1A-105Z1	1
DG887: C1310	CHIP ELECT C	CEWX6.3V-100M	1
DG887: C1311	CHIP ELECT C	CEWX6.3V-22M	1
DG887: C1312	CHIP ELECT C	CEWX6.3V-100M	1
DG887: C1313	CHIP ELECT C	CEWX6.3V-22M	1
DG887: C1314	CHIP ELECT C	CEWX6.3V-100M	1
DG887: C1315	CHIP ELECT C	CEWX6.3V-22M	1
DG887: C1316	CHIP ELECT C	CEWX6.3V-100M	1
DG887: C1317	CHIP ELECT C	CEWX6.3V-22M	1
DG887: C1318	CHIP ELECT C	CEWX6.3V-100M	1
DG887: C1319	CHIP ELECT C	CEWX6.3V-22M	1
DG887: C1320	C-CERA C	CK725B1H-103K1	1
DG887: C1322	C-CERA C	CK725F1A-105Z1	1
DG887: C1323	CHIP ELECT C	CEWX6.3V-100M	1
DG887: C1505	C-CERA C	CK725F1A-105Z1	1
DG887: C1507	C-CERA C	CK725F1A-105Z1	1
DG887: C1508	CHIP ELECT C	CEWX6.3V-22M	1
DG887: C1510	C-CERA C	CK725F1A-105Z1	1
DG887: C1511	CHIP ELECT C	CEWX16V-10M	1
DG887: C1701	C-CERA C	CK725F1A-105Z1	1
DG887: C1702	C-CERA C	CK725B1H-103K1	1
DG887: C1704	C-CERA C	CK725F1A-105Z1	1
DG887: C1705	C-CERA C	CK725F1A-105Z1	1
DG887: C1706	C-CERA C	CK725F1A-105Z1	1
DG887: C1707	C-CERA C	CK725F1A-105Z1	1
DG887: C1708	C-CERA C	CK725F1A-105Z1	1
DG887: C1709	CHIP ELECT C	CEWX6.3V-100M	1
DG887: C1710	C-CERA C	CK725F1A-105Z1	1
DG887: C1801	C-CERA C	CK725F1A-105Z1	1
DG887: C1802	CHIP ELECT C	CEWX4V-220M	1
DG887: C1803	C-CERA C	CK725F1A-105Z1	1
DG887: C1804	C-CERA C	CK725F1A-105Z1	1
DG887: C1805	CHIP ELECT C	CEWX4V-220M	1
DG887: C1806	C-CERA C	CK725F1A-105Z1	1
DG887: C1807	C-CERA C	CK725F1A-105Z1	1
DG887: C1808	C-CERA C	CK725F1A-105Z1	1
DG887: C1809	C-CERA C	CK725F1A-105Z1	1
DG887: C1810	C-CERA C	CK725F1A-105Z1	1
DG887: C1811	C-CERA C	CK725F1A-105Z1	1
DG887: C1812	C-CERA C	CK725F1A-105Z1	1
DG887: C1813	C-CERA C	CC725CH1H-102J1	1
DG887: C1851	C-CERA C	CK725F1A-105Z1	1
DG887: C1852	CHIP ELECT C	CEWX4V-220M	1
DG887: C1853	C-CERA C	CK725F1A-105Z1	1
DG887: C1855	C-CERA C	CC725CH1H-120J1	1
DG887: C1858	C-CERA C	CC725CH1H-120J1	1
DG887: C1901	CHIP ELECT C	CEWX6.3V-100M	1
DG887: C1902	CHIP ELECT C	CEWX6.3V-100M	1
DG887: C1903	CHIP ELECT C	CEWX6.3V-100M	1
DG887: C1904	CHIP ELECT C	CEWX16V-22M	1

DG887: C1905	CHIP ELECT C	CEWX4V-220M			1
DG887: C1906	CHIP ELECT C	CEWX6.3V-100M			7/20 PAGE
DG887: C1907	CHIP ELECT C	CEWX6.3V-100M			1
DG887: C1908	CHIP ELECT C	CEWX6.3V-100M			1
DG887: C1909	CHIP ELECT C	CEWX4V-220M			1
DG887: D1302	C-DIODE	1SS352			1
DG887: D1302 or	C-DIODE	1SS355			(1)
DG887: D1303	C-DIODE	1SS352			1
DG887: D1303 or	C-DIODE	1SS355			(1)
DG887: D1501	C-DIODE	1SS226(TE85L_F)			1
DG887: D1701	C-DIODE	1SS352			1
DG887: D1701 or	C-DIODE	1SS355			(1)
DG887: D1702	ZENER D	UDZS5.6B			1
DG887: D1703	C-DIODE	1SS352			1
DG887: D1703 or	C-DIODE	1SS355			(1)
DG887: D1704	C-DIODE	1SS352			1
DG887: D1704 or	C-DIODE	1SS355			(1)
DG887: L1001	CHOKE COIL	NCH-1477			1
DG887: L1002	CHOKE COIL	NCH-1477			1
DG887: L1003	CHOKE COIL	NCH-1477			1
DG887: L1004	CHOKE COIL	NCH-1477			1
DG887: L1005	CHOKE COIL	NCH-1473			1
DG887: L1006	CHOKE COIL	NCH-1477			1
DG887: L1101	CHOKE COIL	NCH-1471			1
DG887: L1102	CHOKE COIL	NCH-1471			1
DG887: L1103	CHOKE COIL	NCH-1471			1
DG887: L1104	CHOKE COIL	NCH-1477			1
DG887: L1105	CHOKE COIL	NCH-1477			1
DG887: L1106	CHOKE COIL	NCH-1477			1
DG887: L1107	CHOKE COIL	NCH-1477			1
DG887: L1108	CHOKE COIL	NCH-1473			1
DG887: L1109	EMIFIL	BK1608LL241-T			1
DG887: L1110	EMIFIL	BK1608LL241-T			1
DG887: L1111	EMIFIL	BK1608LL241-T			1
DG887: L1201	CHOKE COIL	NCH-1471			1
DG887: L1301	CHOKE COIL	NCH-1471			1
DG887: L1501	CORE	DLP2ADN900HL4L	N		1
DG887: L1502	CORE	DLP2ADN900HL4L	N		1
DG887: L1701	CHOKE COIL	NCH-1477			1
DG887: L1801	CHOKE COIL	NCH-1471			1
DG887: L1802	CHOKE COIL	NCH-1471			1
DG887: L1851	CHOKE COIL	NCH-1471			1
DG887: L1852	EMIFIL	BK1608LL241-T			1
DG887: P1002	FFC SOCKET	FH12-24S-0.5SH(55)	2113-3193+0	N	1
DG887: P1104	SOCKET	NSCT-9P2472	2113-3174+0	N	1
DG887: P1203	SOCKET	NSCT-15P2478	2113-3185+0		1
DG887: P1301	PIN JACK	NPJ-5PDBY456	2113-2018+1	onkyo p/n 25045830	1
DG887: P1303	PIN JACK	NPJ-3PDB401	2113-3183+0		1
DG887: P1401A	SOCKET	16FMN-SMT-A-TF	2113-3186+0		1
DG887: P1501	SOCKET	CSS5019-0311F	2113-3175+0		1
DG887: P1701A	SOCKET	27FMN-SMT-A-TF	2113-3187+0		1
DG887: P1901A	PLUG	L2003P09S0T	2113-3189+0	N	1
DG887: Q1001	TR	HN1A01F-GR			1
DG887: Q1002	TR	HN1A01F-GR			1
DG887: Q1003	TR	2SC2712-GR			1
DG887: Q1004	TR	2SC2712-GR			1
DG887: Q1007	TR	2SC2712-GR			1



DG887: Q1101	IC	ZR36888HLCG	N	1
DG887: Q1102	IC	BR24L08FV-W		8/20 PAGE
DG887: Q1103	IC	S-80127CNMC-JKM-T2		1
DG887: Q1201	IC	BD7967EFS	N	1
DG887: Q1202	IC	NJM3404V		1
DG887: Q1205	IC	BA4510FV		1
DG887: Q1301	IC	BH7868FS	N	1
DG887: Q1502	IC	XC6202P502PR	N	1
DG887: Q1503	TR ARRAY	UPA672T		1
DG887: Q1503 or	TR ARRAY	UM6K1N		(1)
DG887: Q1701	TR	KRA107S		1
DG887: Q1702	IC	S-80130CNMC-JKP-T2	N	1
DG887: Q1703	IC	MPD784225GC-313-8BT-A	N	1
DG887: Q1704	IC	TC7SZ125FU(TE85L_F)		1
DG887: Q1705	IC	TC74VHCT125AFT (EKJ)	onkyo p/n 22241894R2	1
DG887: Q1706	IC	TC7SZ125FU(TE85L_F)		1
DG887: Q1801	IC	M29W160ET-70N6E	N	1
DG887: Q1801 or	IC	MX29LV160CTTC-70G	N	(1)
DG887: Q1802	IC	K4S281632I-UC60	N	1
DG887: Q1802 or	IC	NT5SV8M16DS-6K	N	(1)
DG887: Q1802 or	IC	IS42S16800-6TG	N	(1)
DG887: Q1803	TR	2SK3019		1
DG887: Q1851	IC	TC7WZU04FU(TE12L_F)		1
DG887: Q1901	IC	BA18BC0FP		1
DG887: Q1902	IC	XC6202P502FR	N	1
DG887: Q1903	IC	XC6202P502FR	N	1
DG887: R1001	C-CARBON R	RN72K1J-047JE		1
DG887: R1003	C-CARBON R	RN72K1J-047JE		1
DG887: R1005	C-CARBON R	RN72K1J-221JE		1
DG887: R1006	C-CARBON R	RN72K1J-332JE		1
DG887: R1007	C-CARBON R	RN72K1J-047JE		1
DG887: R1009	C-CARBON R	RN72K1J-047JE		1
DG887: R1011	C-CARBON R	RN72K1J-221JE		1
DG887: R1012	C-CARBON R	RN72K1J-332JE		1
DG887: R1013	C-CARBON R	RN72K1J-000JE		1
DG887: R1014	C-CARBON R	RN72K1J-000JE		1
DG887: R1015	C-CARBON R	RN72K1J-471JE		1
DG887: R1016	C-CARBON R	RN72K1J-000JE		1
DG887: R1017	C-CARBON R	RN72K1J-000JE		1
DG887: R1018	C-CARBON R	RN72K1J-000JE		1
DG887: R1019	C-CARBON R	RN72K1J-000JE		1
DG887: R1020	C-CARBON R	RN72K1J-000JE		1
DG887: R1021	C-CARBON R	RN72K1J-000JE		1
DG887: R1022	C-CARBON R	RN72K1J-104FE		1
DG887: R1023	C-CARBON R	RN72K1J-203FE		1
DG887: R1024	C-CARBON R	RN72K1J-000JE		1
DG887: R1025	C-CARBON R	RN72K1J-470JE		1
DG887: R1026	C-CARBON R	RN72K1J-332JE		1
DG887: R1027	C-CARBON R	RN72K1J-000JE		1
DG887: R1028	C-CARBON R	RN72K1J-000JE		1
DG887: R1029	C-CARBON R	RN72K1J-000JE		1
DG887: R1101	C-CARBON R	RN72K1J-470JE		1
DG887: R1102	C-CARBON R	RN72K1J-103JE		1
DG887: R1103	C-CARBON R	RN72K1J-470JE		1
DG887: R1104	C-CARBON R	RN72K1J-470JE		1
DG887: R1105	C-CARBON R	RN72K1J-470JE		1
DG887: R1106	C-CARBON R	RN72K1J-472JE		1

DG887:R1107	C-CARBON R	RN72K1J-470JE	1
DG887:R1108	C-CARBON R	RN72K1J-470JE	9/20 PAGE
DG887:R1109	C-CARBON R	RN72K1J-103JE	1
DG887:R1110	C-CARBON R	RN72K1J-470JE	1
DG887:R1111	C-CARBON R	RN72K1J-470JE	1
DG887:R1112	C-CARBON R	RN72K1J-470JE	1
DG887:R1113	C-CARBON R	RN72K1J-470JE	1
DG887:R1114	C-CARBON R	RN72K1J-470JE	1
DG887:R1115	C-CARBON R	RN72K1J-470JE	1
DG887:R1116	C-CARBON R	RN72K1J-470JE	1
DG887:R1117	C-CARBON R	RN72K1J-470JE	1
DG887:R1118	C-CARBON R	RN72K1J-470JE	1
DG887:R1119	C-CARBON R	RN72K1J-470JE	1
DG887:R1122	C-CARBON R	RN72K1J-221JE	1
DG887:R1124	C-CARBON R	RN72K1J-153JE	1
DG887:R1126	C-CARBON R	RN72K1J-153JE	1
DG887:R1127	C-CARBON R	RN72K1J-560JE	1
DG887:R1128	C-CARBON R	RN72K1J-103JE	1
DG887:R1130	C-CARBON R	RN72K1J-103JE	1
DG887:R1131	C-CARBON R	RN72K1J-470JE	1
DG887:R1132	C-CARBON R	RN72K1J-101JE	1
DG887:R1133	C-CARBON R	RN72K1J-220JE	1
DG887:R1137	C-CARBON R	RN72K1J-563JE	1
DG887:R1138	C-CARBON R	RN72K1J-470JE	1
DG887:R1139	C-CARBON R	RN72K1J-103JE	1
DG887:R1140	C-CARBON R	RN72K1J-470JE	1
DG887:R1141	C-CARBON R	RN72K1J-221JE	1
DG887:R1142	C-CARBON R	RN72K1J-470JE	1
DG887:R1143	C-CARBON R	RN72K1J-470JE	1
DG887:R1144	C-CARBON R	RN72K1J-221JE	1
DG887:R1146	C-CARBON R	RN72K1J-470JE	1
DG887:R1147	C-CARBON R	RN72K1J-470JE	1
DG887:R1159	C-CARBON R	RN72K1J-102JE	1
DG887:R1161	C-CARBON R	RN72K1J-220JE	1
DG887:R1162	C-CARBON R	RN72K1J-271FE	1
DG887:R1163	C-CARBON R	RN72K1J-151FE	1
DG887:R1164	C-CARBON R	RN72K1J-100FE	1
DG887:R1165	C-CARBON R	RN72K1J-000JE	1
DG887:R1166	C-CARBON R	RN72K1J-000JE	1
DG887:R1167	C-CARBON R	RN72K1J-000JE	1
DG887:R1168	C-CARBON R	RN72K1J-221FE	1
DG887:R1169	C-CARBON R	RN72K1J-151FE	1
DG887:R1170	C-CARBON R	RN72K1J-220FE	1
DG887:R1171	C-CARBON R	RN72K1J-750FE	1
DG887:R1172	C-CARBON R	RN72K1J-750FE	1
DG887:R1173	C-CARBON R	RN72K1J-750FE	1
DG887:R1174	C-CARBON R	RN72K1J-750FE	1
DG887:R1175	C-CARBON R	RN72K1J-750FE	1
DG887:R1176	C-CARBON R	RN72K1J-750FE	1
DG887:R1177	C-CARBON R	RN72K1J-750FE	1
DG887:R1178	C-CARBON R	RN72K1J-750FE	1
DG887:R1179	C-CARBON R	RN72K1J-750FE	1
DG887:R1180	C-CARBON R	RN72K1J-750FE	1
DG887:R1181	C-CARBON R	RN72K1J-750FE	1
DG887:R1182	C-CARBON R	RN72K1J-750FE	1
DG887:R1183	C-CARBON R	RN72K1J-470JE	1
DG887:R1184	C-CARBON R	RN72K1J-470JE	1

DG887: R1188	C-CARBON R	RN72K1J-470JE		1
DG887: R1189	C-CARBON R	RN72K1J-470JE		10/20 PAGE
DG887: R1190	C-CARBON R	RN72K1J-470JE		1
DG887: R1191	C-CARBON R	RN72K1J-473JE		1
DG887: R1192	C-CARBON R	RN72K1J-473JE		1
DG887: R1195	C-CARBON R	RN72K1J-103JE		1
DG887: R1197	C-CARBON R	RN72K1J-000JE		1
DG887: R1198	C-R NET	RM4KJ470X04		1
DG887: R1199	C-R NET	RM4KJ470X04		1
DG887: R1201	C-CARBON R	RN72K1J-102JE		1
DG887: R1202	C-CARBON R	RN72K1J-473JE		1
DG887: R1203	C-CARBON R	RN72K1J-473JE		1
DG887: R1204	C-CARBON R	RN72K1J-047JE		1
DG887: R1205	C-CARBON R	RN72K1J-047JE		1
DG887: R1207	C-CARBON R	RN72K1J-473JE		1
DG887: R1208	C-CARBON R	RN72K1J-010JE		1
DG887: R1209	C-CARBON R	RN72K1J-010JE		1
DG887: R1210	C-CARBON R	RN72K1J-010JE		1
DG887: R1211	C-CARBON R	RN72K1J-010JE		1
DG887: R1212	C-CARBON R	RN72K1J-472JE		1
DG887: R1213	C-CARBON R	RN72K1J-000JE		1
DG887: R1214	C-CARBON R	RN72K1J-000JE		1
DG887: R1215	C-CARBON R	RN72K1J-018JE	N	1
DG887: R1216	C-CARBON R	RN72K1J-018JE	N	1
DG887: R1217	C-CARBON R	RN72K1J-018JE	N	1
DG887: R1218	C-CARBON R	RN72K1J-018JE	N	1
DG887: R1219	C-CARBON R	RN72K1J-018JE	N	1
DG887: R1220	C-CARBON R	RN72K1J-018JE	N	1
DG887: R1221	C-CARBON R	RN72K1J-018JE	N	1
DG887: R1224	C-CARBON R	RN72K1J-273JE		1
DG887: R1226	C-CARBON R	RN72K1J-273JE		1
DG887: R1227	C-CARBON R	RN72K1J-154JE		1
DG887: R1228	C-CARBON R	RN72K1J-223JE		1
DG887: R1237	C-CARBON R	RN72K1J-103FE		1
DG887: R1238	C-CARBON R	RN72K1J-103FE		1
DG887: R1240	C-CARBON R	RN72K1J-100JE		1
DG887: R1241	C-CARBON R	RN72K1J-000JE		1
DG887: R1242	C-CARBON R	RN72K1J-103JE		1
DG887: R1245	C-CARBON R	RN72K1J-273JE		1
DG887: R1246	C-CARBON R	RN72K1J-103JE		1
DG887: R1247	C-CARBON R	RN72K1J-153JE		1
DG887: R1248	C-CARBON R	RN72K1J-183JE		1
DG887: R1249	C-CARBON R	RN72K1J-273JE		1
DG887: R1270	C-R NET	RM4KJ470X04		1
DG887: R1271	C-CARBON R	RN72K1J-470JE		1
DG887: R1272	C-CARBON R	RN72K1J-470JE		1
DG887: R1273	C-CARBON R	RN72K1J-220JE		1
DG887: R1274	C-CARBON R	RN72K1J-220JE		1
DG887: R1275	C-CARBON R	RN72K1J-220JE		1
DG887: R1276	C-CARBON R	RN72K1J-220JE		1
DG887: R1277	C-CARBON R	RN72K1J-220JE		1
DG887: R1278	C-R NET	RM4KJ470X04		1
DG887: R1279	C-R NET	RM4KJ470X04		1
DG887: R1280	C-R NET	RM4KJ470X04		1
DG887: R1281	C-R NET	RM4KJ470X04		1
DG887: R1301	C-CARBON R	RN72K1J-123JE		1
DG887: R1302	C-CARBON R	RN72K1J-123JE		1

DG887: R1304	C-CARBON R	RN72K1J-750JE		1
DG887: R1305	C-CARBON R	RN72K1J-750JE		11/20 PAGE
DG887: R1306	C-CARBON R	RN72K1J-750JE		1
DG887: R1307	C-CARBON R	RN72K1J-103JE		1
DG887: R1311	C-CARBON R	RN72K1J-103JE		1
DG887: R1312	C-CARBON R	RN72K1J-750JE		1
DG887: R1313	C-CARBON R	RN72K1J-750JE		1
DG887: R1314	C-CARBON R	RN72K1J-750JE		1
DG887: R1322	C-CARBON R	RN72K1J-000JE		1
DG887: R1323	C-CARBON R	RN72K1J-102JE		1
DG887: R1324	C-CARBON R	RN72K1J-152JE		1
DG887: R1506	C-CARBON R	RN72K1J-000JE		1
DG887: R1508	C-CARBON R	RN72K1J-000JE		1
DG887: R1510	C-CARBON R	RN72K1J-182JE		1
DG887: R1511	C-CARBON R	RN72K1J-182JE		1
DG887: R1512	C-CARBON R	RN72K1J-471JE		1
DG887: R1514	C-CARBON R	RN72K1J-473JE		1
DG887: R1516	C-CARBON R	RN72K1J-100JE		1
DG887: R1701	C-CARBON R	RN72K1J-220JE		1
DG887: R1702	C-CARBON R	RN72K1J-473JE		1
DG887: R1703	C-CARBON R	RN72K1J-224JE		1
DG887: R1704	C-CARBON R	RN72K1J-563JE		1
DG887: R1708	C-CARBON R	RN72K1J-103JE		1
DG887: R1711	C-CARBON R	RN72K1J-470JE		1
DG887: R1712	C-CARBON R	RN72K1J-470JE		1
DG887: R1713	C-CARBON R	RN72K1J-103JE		1
DG887: R1714	C-CARBON R	RN72K1J-103JE		1
DG887: R1716	C-CARBON R	RN72K1J-103JE		1
DG887: R1717	C-CARBON R	RN72K1J-222JE		1
DG887: R1718	C-CARBON R	RN72K1J-103JE		1
DG887: R1719	C-CARBON R	RN72K1J-103JE		1
DG887: R1720	C-CARBON R	RN72K1J-103JE		1
DG887: R1721	C-CARBON R	RN72K1J-103JE		1
DG887: R1722	C-CARBON R	RN72K1J-103JE		1
DG887: R1723	C-CARBON R	RN72K1J-103JE		1
DG887: R1724	C-CARBON R	RN72K1J-103JE		1
DG887: R1728	C-CARBON R	RN72K1J-220JE		1
DG887: R1731	C-CARBON R	RN72K1J-472JE		1
DG887: R1732	C-CARBON R	RN72K1J-272JE	<CUA> only, <CDD> open	1
DG887: R1733	C-CARBON R	RN72K1J-272JE		1
DG887: R1734	C-CARBON R	RN72K1J-272JE		1
DG887: R1735	C-CARBON R	RN72K1J-272JE		1
DG887: R1736	C-CARBON R	RN72K1J-272JE	<CDD> only, <CUA> open	1
DG887: R1737	C-CARBON R	RN72K1J-472JE		1
DG887: R1738	C-CARBON R	RN72K1J-272JE		1
DG887: R1739	C-CARBON R	RN72K1J-391JE		1
DG887: R1740	C-CARBON R	RN72K1J-272JE		1
DG887: R1741	C-CARBON R	RN72K1J-220JE		1
DG887: R1742	C-CARBON R	RN72K1J-220JE		1
DG887: R1743	C-CARBON R	RN72K1J-220JE		1
DG887: R1744	C-CARBON R	RN72K1J-220JE		1
DG887: R1745	C-CARBON R	RN72K1J-220JE		1
DG887: R1747	C-CARBON R	RN72K1J-272JE		1
DG887: R1748	C-CARBON R	RN72K1J-470JE		1
DG887: R1749	C-CARBON R	RN72K1J-470JE		1
DG887: R1750	C-CARBON R	RN72K1J-470JE		1
DG887: R1751	C-CARBON R	RN72K1J-272JE		1

DG887:R1754	C-CARBON R	RN72K1J-000JE	1
DG887:R1755	C-CARBON R	RN72K1J-470JE	12/20 PAGE
DG887:R1756	C-CARBON R	RN72K1J-470JE	1
DG887:R1757	C-CARBON R	RN72K1J-470JE	1
DG887:R1758	C-CARBON R	RN72K1J-470JE	1
DG887:R1759	C-CARBON R	RN72K1J-473JE	1
DG887:R1760	C-CARBON R	RN72K1J-103JE	1
DG887:R1761	C-CARBON R	RN72K1J-103JE	1
DG887:R1764	C-CARBON R	RN72K1J-000JE	1
DG887:R1765	C-CARBON R	RN72K1J-103JE	1
DG887:R1767	C-CARBON R	RN72K1J-103JE	1
DG887:R1768	C-CARBON R	RN72K1J-103JE	1
DG887:R1801	C-CARBON R	RN72K1J-103JE	1
DG887:R1802	C-CARBON R	RN72K1J-102JE	1
DG887:R1803	C-CARBON R	RN72K1J-102JE	1
DG887:R1804	C-CARBON R	RN72K1J-102JE	1
DG887:R1805	C-CARBON R	RN72K1J-472JE	1
DG887:R1806	C-CARBON R	RN72K1J-472JE	1
DG887:R1807	C-CARBON R	RN72K1J-000JE	1
DG887:R1808	C-CARBON R	RN72K1J-472JE	1
DG887:R1810	C-CARBON R	RN72K1J-103JE	1
DG887:R1851	C-CARBON R	RN72K1J-470JE	1
DG887:R1852	C-CARBON R	RN72K1J-103JE	1
DG887:R1853	C-CARBON R	RN72K1J-105FE	1
DG887:R1854	C-CARBON R	RN72K1J-561FE	1
DG887:R1856	C-CARBON R	RN72K1J-221JE	1
DG887:R1901	C-CARBON R	RN72K1J-000JE	1
DG887:R1902	C-CARBON R	RN72K1J-000JE	1
DG887:R1903	C-CARBON R	RN72K1J-000JE	1
DG887:R1904	C-CARBON R	RN72K1J-000JE	1
DG887:R1905	C-CARBON R	RN72K1J-000JE	1
DG887:R1906	C-CARBON R	RN72K1J-000JE	1
DG887:R1907	C-CARBON R	RN72K1J-000JE	1
DG887:R1911	C-CARBON R	RN72K1J-000JE	1
DG887:X1701	CERA LOCK	CSTCE12M5G52-R0	1
DG887:X1851	CRYSTAL	FCX-03-27MHz	1

## PRINTED CIRCUIT BOARD PARTS LIST

DV-CP704

- U002 : DISPLAY CIRCUIT PC BOARD NADIS-8859-1A <CDD1N> <CUA4P>**
- U002-1 : ROULETTE CONTROL PC BOARD NADG-8860-1A**
- U002-2 : AUDIO OUTPUT PC BOARD NAAF-8861-1A**
- U002-3 : RI TERMINAL PC BOARD NADG-8862-1A**
- U002-4 : STANDBY SWITCH PC BOARD NASW-8866-1A**
- U002-5 : ILLUMINATION PC BOARD NADIS-8867-1A**
- U002-6 : DISC SENSOR PC BOARD NAETC-8868-1A**
- U002-7 : CONNECTION PC BOARD NAETC-8870-1A**
- U002-8 : LOADING MOTOR PC BOARD NAETC-8872-1A**
- U002-9 : ROULETTE MOTOR PC BOARD NAETC-8873-1A**
- J002-10 : KEY OPERATION PC BOARD NASW-8863-1A**
- J002-11 : DISC OPERATION PC BOARD NASW-8864-1A**

PCB	CIRCUIT	PART NAME	DESCRIPTION	GPE PART NO.	REMARKS
DIS885	C4001	TF C	ECQ-B50V-331K	153F-331K+K-MM	1
DIS885	C4002	TF C	ECQ-B50V-331K	153F-331K+K-MM	1
DIS885	C4003	TF C	ECQ-B50V-181K	153F-181K+K-MM	1
DIS885	C4004	TF C	ECQ-B50V-181K	153F-181K+K-MM	1
DIS885	C4005	TF C	ECQ-B50V-181K	153F-181K+K-MM	1

DIS885	C4006	TF C	ECQ-B50V-181K	153F-181K+K-MM		1
DIS885	C4007	TF C	ECQ-B50V-122J	153F-122J+K-MMN		13/20 PAGE
DIS885	C4008	TF C	ECQ-B50V-122J	153F-122J+K-MMN		1
DIS885	C4009	TF C	ECQ-B50V-272J	153F-272J+K-MMN		1
DIS885	C4010	TF C	ECQ-B50V-272J	153F-272J+K-MMN		1
DIS885	C4011	VX C	CE04W50V 47M(VX_BLK)	1511-476M+K-0F-*		1
DIS885	C4016	VX C	CE04W50V-10M(VX_BLK)	1511-106M+K-0F-*		1
DIS885	C4017	TF C	ECQ-V50V-104J	153F-104J+K-MMN		1
DIS885	C4018	VX C	CE04W6.3V-470M(VX_BLK)	157B-477M+K-OV-*		1
DIS885	C4019	VX C	CE04W6.3V-470M(VX_BLK)	157B-477M+K-OV-*		1
DIS885	C4020	TF C	ECQ-V50V-104J	153F-104J+K-MMN		1
DIS885	C4021	TF C	ECQ-V50V-104J	153F-104J+K-MMN		1
DIS885	C4023	VX C	CE04W6.3V-470M(VX_BLK)	157B-477M+K-OV-*		1
DIS885	C4024	TF C	ECQ-V50V-104J	153F-104J+K-MMN		1
DIS885	C4025	TF C	ECQ-V50V-104J	153F-104J+K-MMN		1
DIS885	C4027	VX C	CE04W16V-470M(VX_BLK)	157D-477M+K-SX-*		1
DIS885	C4028	VX C	CE04W16V-470M(VX_BLK)	157D-477M+K-SX-*		1
DIS885	C4029	VX C	CE04W16V-470M(VX_BLK)	157D-477M+K-SX-*		1
DIS885	C4030	VX C	CE04W16V-470M(VX_BLK)	157D-477M+K-SX-*		1
DIS885	C4031	ELECT C	CE04W16V-1000M(SC)	157D-477M+K-SX-*		1
DIS885	C4032	TF C	ECQ-V50V-104J	153F-104J+K-MMN		1
DIS885	C4033	TF C	ECQ-V50V-104J	153F-104J+K-MMN		1
DIS885	C4034	C-CERA C	CC725CH1H-020C1	15CH-020C+P-AC-*		1
DIS885	C4035	C-CERA C	CK725B1C-104K1	150D-104K+P-AC-*		1
DIS885	C4036	ELECT C	CE04W6.3V-220M(SC)	157B-227M+K-IUI		1
DIS885	C4037	C-CERA C	CK725F1H-104Z1	150F-104Z+P-AC-*		1
DIS885	C4038	C-CERA C	CK725F1H-104Z1	150F-104Z+P-AC-*		1
DIS885	C4040	C-CERA C	CC725CH1H-220J1	15CH-220J+P-AC-*		1
DIS885	C4041	C-CERA C	CK725B1C-104K1	150D-104K+P-AC-*		1
DIS885	C4042	C-CERA C	CC725CH1H-020C1	15CH-020C+P-AC-*		1
DIS885	C4043	C-CERA C	CK725F1H-104Z1	150F-104Z+P-AC-*		1
DIS885	C4044	ELECT C	CE04W6.3V-220M(SC)	157B-227M+K-IUI		1
DIS885	C4046	C-CERA C	CK725F1A-105Z1	150C-105Z+P-AC-*		1
DIS885	C7001	C-CERA C	CC725CH1H-101J1	15CH-101J+P-AC-*		1
DIS885	C7002	C-CERA C	CK725F1H-104Z1	150F-104Z+P-AC-*		1
DIS885	C7004	C-CERA C	CK725F1H-104Z1	150F-104Z+P-AC-*		1
DIS885	C7005	C-CERA C	CK725F1H-223Z1	150F-223M+P-AC-*		1
DIS885	C7006	C-CERA C	CK725F1H-104Z1	150F-104Z+P-AC-*		1
DIS885	C7010	ELECT C	CE04W16V-47M(SSK)	157D-476M+H-LI4	N	1
DIS885	C7011	C-CERA C	CK725F1H-223Z1	150F-223M+P-AC-*		1
DIS885	C7013	C-CERA C	CK725F1H-104Z1	150F-104Z+P-AC-*		1
DIS885	C7021	C-CERA C	CK725F1H-104Z1	150F-104Z+P-AC-*		1
DIS885	C7022	ELECT C	CE04W16V-100M(SSK)	157D-107M+K-LII		1
DIS885	C7023	C-CERA C	CK725F1H-104Z1	150F-104Z+P-AC-*		1
DIS885	C7024	ELECT C	CE04W16V-100M(SSK)	157D-107M+K-LII		1
DIS885	C7025	C-CERA C	CK725F1H-104Z1	150F-104Z+P-AC-*		1
DIS885	C7026	C-CERA C	CK725F1H-104Z1	150F-104Z+P-AC-*		1
DIS885	C7027	C-CERA C	CK725F1H-104Z1	150F-104Z+P-AC-*		1
DIS885	C7030	ELECT C	CE04W16V-220M(SC)	157D-227M+K-LUI		1
DIS885	C7031	ELECT C	CE04W16V-220M(SC)	157D-227M+K-LUI		1
DIS885	C7034	ELECT C	CE04W16V-220M(SC)	157D-227M+K-LUI		1
DIS885	C8001	ELECT C	CE04W50V-2.2M(SSK)	157F-225M+K-GII		1
DIS885	C8005	C-CERA C	CK725F1H-104Z1	150F-104Z+P-AC-*		1
DIS885	C8006	C-CERA C	CK725B1H-102K1	15CH-102J+P-AC-*		1
DIS885	C8007	ELECT C	CE04W16V-10M(SSK)	157D-106M+K-GII		1
DIS885	C8008	C-CERA C	CK725B1H-102K1	15CH-102J+P-AC-*		1
DIS885	C8009	C-CERA C	CK725F1H-104Z1	150F-104Z+P-AC-*		1

DIS885	C8010	C-CERA C	CK725F1H-104Z1	150F-104Z+P-AC-*		1
DIS885	C8011	C-CERA C	CK725F1H-104Z1	150F-104Z+P-AC-*		14/20 PAGE
DIS885	C8012	C-CERA C	CK725F1H-104Z1	150F-104Z+P-AC-*		1
DIS885	C8013	C-CERA C	CK725F1H-104Z1	150F-104Z+P-AC-*		1
DIS885	C8014	C-CERA C	CK725F1H-104Z1	150F-104Z+P-AC-*		1
DIS885	C8015	C-CERA C	CK725F1H-104Z1	150F-104Z+P-AC-*		1
DIS885	C8016	C-CERA C	CK725F1H-104Z1	150F-104Z+P-AC-*		1
DIS885	C8017	C-CERA C	CK725F1H-104Z1	150F-104Z+P-AC-*		1
DIS885	C8018	C-CERA C	CK725F1H-104Z1	150F-104Z+P-AC-*		1
DIS885	C8021	C-CERA C	CC725CH1H-330J1	15CH-330J+P-AC-*		1
DIS885	C8023	C-CERA C	CK725F1H-104Z1	150F-104Z+P-AC-*		1
DIS885	C8024	C-CERA C	CC725CH1H-330J1	15CH-330J+P-AC-*		1
DIS885	C8025	C-CERA C	CK725F1H-104Z1	150F-104Z+P-AC-*		1
DIS885	C8026	C-CERA C	CK725F1H-104Z1	150F-104Z+P-AC-*		1
DIS885	C8027	C-CERA C	CC725CH1H-330J1	15CH-330J+P-AC-*		1
DIS885	C8028	C-CERA C	CC725CH1H-330J1	15CH-330J+P-AC-*		1
DIS885	C8029	C-CERA C	CK725F1H-104Z1	150F-104Z+P-AC-*		1
DIS885	C8030	C-CERA C	CK725F1H-104Z1	150F-104Z+P-AC-*		1
DIS885	C8031	ELECT C	CE04W16V-100M(SC)	157D-107M+K-LII		1
DIS885	C8032	C-CERA C	CK725F1H-104Z1	150F-104Z+P-AC-*		1
DIS885	C8033	CERA C	CK45F50V-223Z	150F-223Z+K-RE		1
DIS885	C8034	CERA C	CK45F50V-223Z	150F-223Z+K-RE		1
DIS885	C8035	CERA C	CK45F50V-223Z	150F-223Z+K-RE		1
DIS885	C8036	CERA C	CK45F50V-223Z	150F-223Z+K-RE		1
DIS885	C8037	CERA C	CK45F50V-223Z	150F-223Z+K-RE		1
DIS885	C8038	C-CERA C	CK725F1H-104Z1	150F-104Z+P-AC-*		1
DIS885	C8039	C-CERA C	CK725F1H-104Z1	150F-104Z+P-AC-*		1
DIS885	D4001	C-DIODE	1SS355	4840-1660+3-*		1
DIS885	D4001 or	C-DIODE	1SS352			(1)
DIS885	D4003	C-DIODE	1SS355	4840-1660+3-*		1
DIS885	D4003 or	C-DIODE	1SS352			(1)
DIS885	D4004	C-DIODE	1SS355	4840-1660+3-*		1
DIS885	D4004 or	C-DIODE	1SS352			(1)
DIS885	D7002	ZENER D	UDZ2.7B	483H-2V71+3		1
DIS885	D7003	ZENER D	UDZS4.3B	483H-4V31+3-*		1
DIS885	D7004	C-DIODE	1SS355	4840-1660+3-*		1
DIS885	D7004 or	C-DIODE	1SS352			(1)
DIS885	D7005	C-DIODE	1SS355	4840-1660+3-*		1
DIS885	D7005 or	C-DIODE	1SS352			(1)
DIS885	D8001	LED	SDPB31D0C0000- M03 N03 P03	3700-1631+B	N	1
DIS885	D8001A	HOLDER	(LED)LA-5-6	4171-0021+0		1
DIS885	D8002	ZENER D	UDZS5.6B	483H-5B61+3-*		1
DIS885	D8003	LED	SDPB31D0C0000- M03 N03 P03	3700-1631+B	N	1
DIS885	D8003A	HOLDER	(LED)LA-5-6	4171-0021+0		1
DIS885	D8004	LED	SLI-343URC-T32	3700-2839+R		1
DIS885	E7001	TRM(SCREW)	NEJITANSI M3	4135-2421+0		1
DIS885	E7003	WS CLAMP	CB-71683(L=50)	7012-8040+0		1
DIS885	E7006	WS CLAMP	CB-71683(L=50)	7012-8040+0		1
DIS885	L4001	CHOKE COIL	NCH-1471	1803-0064+0		1
DIS885	L4003	CHOKE COIL	NCH-1471	1803-0064+0		1
DIS885	L4006	EMIFIL	BK1608LM182-T	1806-3647+0		1
DIS885	L4007	EMIFIL	BK1608LM182-T	1806-3647+0		1
DIS885	L4008	EMIFIL	BK1608LM182-T	1806-3647+0		1
DIS885	L7001	EMIFIL	BK1608LM182-T	1806-3647+0		1
DIS885	L7007	CHOKE COIL	NCH-3608L100	1807-100Q+P	N	1
DIS885	L7008	CHOKE COIL	NCH-3608K470	1803-0075+0		1
DIS885	L7009	CHOKE COIL	NCH-1473	1803-0086+0		1

DIS885 L7010	CHOCKE COIL	NCH-1473	1803-0086+0		1
DIS885 P1401B	SOCKET	NSCT-16P2213	2113-1858+0		15/20 PAGE
DIS885 P1701B	SOCKET	NSCT-27P2261	2113-3177+0		1
DIS885 P1701Bor	SOCKET	NSCT-27P2445			(1)
DIS885 P1901B	PLUG	2003P0900T	2113-3190+0	N	1
DIS885 P4004	PIN JACK	NPJ-2PDRW435			1
DIS885 P4004 or	PIN JACK	NPJ-2PDWR595			(1)
DIS885 P4004 or	PIN JACK	NPJ-2PDRW608	2113-2020+1		(1)
DIS885 P4006	PIN JACK	NPJ-1PDOR369			1
DIS885 P4006 or	PIN JACK	NPJ-1PDO596			(1)
DIS885 P4006 or	PIN JACK	NPJ-1PDOR607	2113-2021+1		(1)
DIS885 P4007	SOCKET AS	NSAS-6P1613	7012-8000+0	N	1
DIS885 P7001	PIN JACK	NPJ-2PDB400	2113-2022+0		1
DIS885 P7001 or	PIN JACK	MSJ-035-36A			(1)
DIS885 P7002A	SOCKET	NSCT-6P2099	2101-1421+0-*		1
DIS885 P7002Aor	SOCKET	NSCT-6P1600			(1)
DIS885 P7002Aor	SOCKET	NSCT-6P1802			(1)
DIS885 P7002B	SOCKET	NSCT-6P2136	2101-1422+0-*		1
DIS885 P7002B or	SOCKET	NSCT-6P1839			(1)
DIS885 P7002B or	SOCKET	NSCT-6P1637			(1)
DIS885 P7005	SOCKET AS	NSAS-4P1410	7012-6808+0		1
DIS885 P7005A	PLUG	2002P0200T	2101-3007+0		1
DIS885 P7009	SOCKET AS	NSAS-4P1409	7012-6807+0		1
DIS885 P7009A	PLUG	2003P0200T	2101-3012+0		1
DIS885 P7013	SOCKET AS	NSAS-12P1586	7012-8050+0	N	1
DIS885 P7013A	PLUG	2003P0600T	2113-3191+0		1
DIS885 P7016	SOCKET AS	NSAS-14P1587	7012-8060+0	N	1
DIS885 P7016A	PLUG	2002P0700T	2101-3009+0		1
DIS885 P7018	SOCKET AS	NSAS-20P1588	7012-8070+0	N	1
DIS885 P7018A	PLUG	2003P1000T	2113-3180+0	N	1
DIS885 P7019	SOCKET AS	NSAS-12P1589	7012-8051+0	N	1
DIS885 P7019A	PLUG	2003P0600T	2113-3191+0		1
DIS885 P8002	SOCKET AS	NSAS-4P1593	7012-8110+0	N	1
DIS885 P8005	SOCKET AS	NSAS-10P1594	7012-8120+0	N	1
DIS885 P8008	PLUG	2002P0800T	2113-3192+0	N	1
DIS885 P8008A	SOCKET AS	NSAS-16P1590	7012-8080+0	N	1
DIS885 P8012	SOCKET AS	NSAS-8P1592	7012-8100+0	N	1
DIS885 P8012A	PLUG	2002P0400T	2113-3179+0	N	1
DIS885 P902	SOCKET AS	NSAS-30P1603	7012-7990+0	N	1
DIS885 Q4001	IC	NJM4580M-D	3131-9970+0-*		1
DIS885 Q4002	IC	NJM4580M-D	3131-9970+0-*		1
DIS885 Q4003	IC	NJM4580M-D	3131-9970+0-*		1
DIS885 Q4004	IC	NJM4580M-D	3131-9970+0-*		1
DIS885 Q4005	TR	2SD655-E	485D-655E+K		1
DIS885 Q4005 or	TR	2SD655-F			(1)
DIS885 Q4006	TR	2SD655-E	485D-655E+K		1
DIS885 Q4006 or	TR	2SD655-F			(1)
DIS885 Q4007	TR	2SD655-E	485D-655E+K		1
DIS885 Q4007 or	TR	2SD655-F			(1)
DIS885 Q4008	TR	2SD655-E	485D-655E+K		1
DIS885 Q4008 or	TR	2SD655-F			(1)
DIS885 Q4009	IC	TC7SET04FU(TE85L_F)	3132-4261+0		1
DIS885 Q4010	IC	WM8718	3132-4241+0		1
DIS885 Q4011	IC	S-812C50AUA-C3E	3132-4251+0		1
DIS885 Q4012	TR	DTA114YKA	485A-1140+3-*		1
DIS885 Q4012 or	TR	RN2407(TE85L_F)			(1)
DIS885 Q4012 or	TR	KRA107S			(1)



DIS885 Q4013	TR	DTA114YKA	485A-1140+3-*	1
DIS885 Q4013 or	TR	RN2407(TE85L_F)		16/20 PAGE
DIS885 Q4013 or	TR	KRA107S		(1)
DIS885 Q4014	TR	KRC107S		1
DIS885 Q4014 or	TR	DTC114YKA	485C-1140+3-*	(1)
DIS885 Q4014 or	TR	RN1407		(1)
DIS885 Q4015	IC	TC74VHCU04FT	3131-9960+0-*	1
DIS885 Q4016	PHT CP	GP1FAV51TKBF	4811-TKBF+1	1
DIS885 Q7001	TR	KRC107S		1
DIS885 Q7001 or	TR	DTC114YKA	485C-1140+3-*	(1)
DIS885 Q7001 or	TR	RN1407		(1)
DIS885 Q7002	TR	KRC107S		1
DIS885 Q7002 or	TR	DTC114YKA	485C-1140+3-*	(1)
DIS885 Q7002 or	TR	RN1407		(1)
DIS885 Q7003	PHT INT	GP2S28	481P-2S28+3-*	1
DIS885 Q7007	TR	KRC107S		1
DIS885 Q7007 or	TR	DTC114YKA	485C-1140+3-*	(1)
DIS885 Q7007 or	TR	RN1407		(1)
DIS885 Q7008	TR	KRC107S		1
DIS885 Q7008 or	TR	DTC114YKA	485C-1140+3-*	(1)
DIS885 Q7008 or	TR	RN1407		(1)
DIS885 Q7009	PHT CP	RPI-576	481P-I576+3	1
DIS885 Q7010	IC	TA7291SG(5_J)	3131-7990+0	1
DIS885 Q7013	TR	KRC107S		1
DIS885 Q7013 or	TR	DTC114YKA	485C-1140+3-*	(1)
DIS885 Q7013 or	TR	RN1407		(1)
DIS885 Q7014	IC	TA7291SG(5_J)	3131-7990+0	1
DIS885 Q7015	TR	2SA1162-Y(TE85R_F)	4851-162G+3	1
DIS885 Q7015 or	TR	2SA1162-GR		(1)
DIS885 Q7016	TR	KRA107S		1
DIS885 Q7016 or	TR	DTA114YKA	485A-1140+3-*	(1)
DIS885 Q7016 or	TR	RN2407(TE85L_F)		(1)
DIS885 Q7017	TR	2SD655-E	485D-655E+K	1
DIS885 Q7017 or	TR	2SD655-F		(1)
DIS885 Q7018	TR	2SD655-E	485D-655E+K	1
DIS885 Q7018 or	TR	2SD655-F		(1)
DIS885 Q8001	FL TUBE	HNV-12SM34	2460-2020+0	1
DIS885 Q8001A	HOLDER	(FL)	4154-6111+0	1
DIS885 Q8001B	SCREW	3TTB+6B(3BC)	2954-3006+3000	2
DIS885 Q8002	TR	2SC2712-GR	4852-712G+3-*	1
DIS885 Q8002 or	TR	KTC3875-GR		(1)
DIS885 Q8003	IC	MPD780232GC-091-8BT	3132-0940+0	1
DIS885 Q8004	TR	2SC2712-GR	4852-712G+3-*	1
DIS885 Q8004 or	TR	KTC3875-GR		(1)
DIS885 Q8005	TR	KRC107S		1
DIS885 Q8005 or	TR	DTC114YKA	485C-1140+3-*	(1)
DIS885 Q8005 or	TR	RN1407		(1)
DIS885 Q8006	REMO SENS	RPM7138	481M-7138+3	1
DIS885 Q8007	TR	KRC107S		1
DIS885 Q8007 or	TR	DTC114YKA	485C-1140+3-*	(1)
DIS885 Q8007 or	TR	RN1407		(1)
DIS885 R4001	C-CARBON R	RN72K1J-122FE	4723-122A+P	1
DIS885 R4002	C-CARBON R	RN72K1J-122FE	4723-122A+P	1
DIS885 R4003	C-CARBON R	RN72K1J-122FE	4723-122A+P	1
DIS885 R4004	C-CARBON R	RN72K1J-122FE	4723-122A+P	1
DIS885 R4005	C-CARBON R	RN72K1J-112FE	4723-112A+P	N 1
DIS885 R4006	C-CARBON R	RN72K1J-112FE	4723-112A+P	N 1

DIS885	R4007	C-CARBON R	RN72K1J-112FE	4723-112A+P	N	1
DIS885	R4008	C-CARBON R	RN72K1J-112FE	4723-112A+P	N	17/20 PAGE
DIS885	R4009	C-CARBON R	RN72K1J-472FE	4723-472A+P		1
DIS885	R4010	C-CARBON R	RN72K1J-472FE	4723-472A+P		1
DIS885	R4011	C-CARBON R	RN72K1J-472FE	4723-472A+P		1
DIS885	R4012	C-CARBON R	RN72K1J-472FE	4723-472A+P		1
DIS885	R4013	C-CARBON R	RN72K1J-103JE	4723-103J+P-R		1
DIS885	R4014	C-CARBON R	RN72K1J-103JE	4723-103J+P-R		1
DIS885	R4015	C-CARBON R	RN72K1J-103JE	4723-103J+P-R		1
DIS885	R4016	C-CARBON R	RN72K1J-103JE	4723-103J+P-R		1
DIS885	R4017	C-CARBON R	RN72K1J-152JE	4723-152J+P-R		1
DIS885	R4018	C-CARBON R	RN72K1J-152JE	4723-152J+P-R		1
DIS885	R4019	C-CARBON R	RN72K1J-223JE	4723-223J+P-R		1
DIS885	R4020	C-CARBON R	RN72K1J-223JE	4723-223J+P-R		1
DIS885	R4021	C-CARBON R	RN72K1J-223JE	4723-223J+P-R		1
DIS885	R4022	C-CARBON R	RN72K1J-223JE	4723-223J+P-R		1
DIS885	R4023	C-CARBON R	RN72K1J-223JE	4723-223J+P-R		1
DIS885	R4024	C-CARBON R	RN72K1J-223JE	4723-223J+P-R		1
DIS885	R4025	C-CARBON R	RN72K1J-223JE	4723-223J+P-R		1
DIS885	R4026	C-CARBON R	RN72K1J-223JE	4723-223J+P-R		1
DIS885	R4027	C-CARBON R	RN72K1J-152JE	4723-152J+P-R		1
DIS885	R4028	C-CARBON R	RN72K1J-152JE	4723-152J+P-R		1
DIS885	R4029	C-CARBON R	RN72K1J-152JE	4723-152J+P-R		1
DIS885	R4030	C-CARBON R	RN72K1J-152JE	4723-152J+P-R		1
DIS885	R4033	C-CARBON R	RN72K1J-103JE	4723-103J+P-R		1
DIS885	R4034	C-CARBON R	RN72K1J-103JE	4723-103J+P-R		1
DIS885	R4035	C-CARBON R	RN72K1J-474JE	4723-474J+P-R		1
DIS885	R4036	C-CARBON R	RN72K1J-474JE	4723-474J+P-R		1
DIS885	R4037	C-CARBON R	RN72K1J-221JE	4723-221J+P-R		1
DIS885	R4038	C-CARBON R	RN72K1J-221JE	4723-221J+P-R		1
DIS885	R4039	C-CARBON R	RN72K1J-222JE	4723-222J+P-R		1
DIS885	R4040	C-CARBON R	RN72K1J-222JE	4723-222J+P-R		1
DIS885	R4041	C-CARBON R	RN72K1J-222JE	4723-222J+P-R		1
DIS885	R4042	C-CARBON R	RN72K1J-222JE	4723-222J+P-R		1
DIS885	R4043	C-CARBON R	RN72K1J-221JE	4723-221J+P-R		1
DIS885	R4044	C-CARBON R	RN72K1J-221JE	4723-221J+P-R		1
DIS885	R4045	C-CARBON R	RN72K1J-101JE	4723-101J+P-R		1
DIS885	R4046	C-CARBON R	RN72K1J-101JE	4723-101J+P-R		1
DIS885	R4048	C-CARBON R	RN72K1J-000JE	4723-000J+P-R		1
DIS885	R4049	C-CARBON R	RN72K1J-471JE	4723-471J+P-R		1
DIS885	R4051	C-CARBON R	RN72K1J-330JE	4723-330J+P-R		1
DIS885	R4052	METAL O R	RS1/2WBJ-22	4717-220J+K-X		1
DIS885	R4053	METAL O R	RS1/2WBJ-22	4717-220J+K-X		1
DIS885	R4054	C-CARBON R	RN72K1J-684JE	4723-684J+P-R		1
DIS885	R4057	C-CARBON R	RN72K1J-274JE	4723-274J+P-R		1
DIS885	R4058	C-CARBON R	RN72K1J-562JE	4723-562J+P-R		1
DIS885	R4059	C-CARBON R	RN72K1J-000JE	4723-000J+P-R		1
DIS885	R4061	C-CARBON R	RN72K1J-101JE	4723-101J+P-R		1
DIS885	R4062	C-CARBON R	RN72K1J-101JE	4723-101J+P-R		1
DIS885	R4065	C-CARBON R	RN72K1J-101JE	4723-101J+P-R		1
DIS885	R4066	C-CARBON R	RN72K1J-101JE	4723-101J+P-R		1
DIS885	R4067	C-CARBON R	RN72K1J-103JE	4723-103J+P-R		1
DIS885	R4068	C-CARBON R	RN72K1J-101JE	4723-101J+P-R		1
DIS885	R4069	C-CARBON R	RN72K1J-101JE	4723-101J+P-R		1
DIS885	R4070	C-CARBON R	RN72K1J-101JE	4723-101J+P-R		1
DIS885	R4071	C-CARBON R	RN72K1J-101JE	4723-101J+P-R		1
DIS885	R4072	C-CARBON R	RN72K1J-474JE	4723-474J+P-R		1

DIS885	R4073	C-CARBON R	RN72K1J-101JE	4723-101J+P-R	1
DIS885	R4074	C-CARBON R	RN72K1J-331JE	4723-331J+P-R	18/20 PAGE
DIS885	R4077	C-CARBON R	RN72K1J-181JE	4723-181J+P-R	1
DIS885	R4078	C-CARBON R	RN72K1J-181JE	4723-181J+P-R	1
DIS885	R4079	C-CARBON R	RN72K1J-000JE	4723-000J+P-R	1
DIS885	R4080	C-CARBON R	RN72K1J-101JE	4723-101J+P-R	1
DIS885	R4081	C-CARBON R	RN72K1J-101JE	4723-101J+P-R	1
DIS885	R4501	C-CARBON R	RN72K1J-000JE	4723-000J+P-R	1
DIS885	R4502	C-CARBON R	RN72K1J-000JE	4723-000J+P-R	1
DIS885	R7002	C-CARBON R	RN72K1J-332JE	4723-332J+P-R	1
DIS885	R7003	C-CARBON R	RN72K1J-103JE	4723-103J+P-R	1
DIS885	R7004	C-CARBON R	RN72K1J-822JE	4723-822J+P-R	1
DIS885	R7005	C-CARBON R	RN72K1J-223JE	4723-223J+P-R	1
DIS885	R7006	C-CARBON R	RN72K1J-105JE	4723-105J+P-R	1
DIS885	R7007	C-CARBON R	RN72K1J-181JE	4723-181J+P-R	1
DIS885	R7012	C-CARBON R	RN72K1J-154JE	4723-154J+P-R	1
DIS885	R7014	C-CARBON R	RN72K1J-562JE	4723-562J+P-R	1
DIS885	R7015	C-CARBON R	RN72K1J-103JE	4723-103J+P-R	1
DIS885	R7017	C-CARBON R	RN72K1J-391JE	4723-391J+P-R	1
DIS885	R7018	C-CARBON R	RN72K1J-822JE	4723-822J+P-R	1
DIS885	R7019	C-CARBON R	RN72K1J-472JE	4723-472J+P-R	1
DIS885	R7020	C-CARBON R	RN72K1J-105JE	4723-105J+P-R	1
DIS885	R7021	C-CARBON R	RN72K1J-474JE	4723-474J+P-R	1
DIS885	R7023	C-CARBON R	RN72K1J-471JE	4723-471J+P-R	1
DIS885	R7024	C-CARBON R	RN72K1J-104JE	4723-104J+P-R	1
DIS885	R7025	C-CARBON R	RN72K1J-104JE	4723-104J+P-R	1
DIS885	R7028	NF CARBON R	R25J-4.7	4705-4R7J+K-P-*	1
DIS885	R7032	C-CARBON R	RN72K1J-000JE	4723-000J+P-R	1
DIS885	R7034	C-CARBON R	RN72K1J-222JE	4723-222J+P-R	1
DIS885	R7039	C-CARBON R	RN72K1J-104JE	4723-104J+P-R	1
DIS885	R7040	C-CARBON R	RN72K1J-104JE	4723-104J+P-R	1
DIS885	R7041	NF CARBON R	R25J-4.7	4705-4R7J+K-P-*	1
DIS885	R7042	C-CARBON R	RN72K1J-562JE	4723-562J+P-R	1
DIS885	R7043	C-CARBON R	RN72K1J-822JE	4723-822J+P-R	1
DIS885	R7045	C-CARBON R	RN72K1J-222JE	4723-222J+P-R	1
DIS885	R7047	C-CARBON R	RN72K1J-272JE	4723-272J+P-R	1
DIS885	R7048	C-CARBON R	RN72K1J-000JE	4723-000J+P-R	1
DIS885	R7050	C-CARBON R	RN72K1J-562JE	4723-562J+P-R	1
DIS885	R7051	C-CARBON R	RN72K1J-103JE	4723-103J+P-R	1
DIS885	R7052	C-CARBON R	RN72K1J-103JE	4723-103J+P-R	1
DIS885	R7053	C-CARBON R	RN72K1J-103JE	4723-103J+P-R	1
DIS885	R7054	C-CARBON R	RN72K1J-272JE	4723-272J+P-R	1
DIS885	R7055	C-CARBON R	RN72K1J-104JE	4723-104J+P-R	1
DIS885	R7056	C-CARBON R	RN72K1J-223JE	4723-223J+P-R	1
DIS885	R7057	C-CARBON R	RN72K1J-223JE	4723-223J+P-R	1
DIS885	R7059	METAL R	RNU1/2WCJ-4.7	4717-4R7J+K-X	1
DIS885	R7503	C-CARBON R	RN72K1J-000JE	4723-000J+P-R	1
DIS885	R7504	C-CARBON R	RN72K1J-000JE	4723-000J+P-R	1
DIS885	R7505	C-CARBON R	RN72K1J-000JE	4723-000J+P-R	1
DIS885	R7506	C-CARBON R	RN72K1J-000JE	4723-000J+P-R	1
DIS885	R7507	C-CARBON R	RN72K1J-000JE	4723-000J+P-R	1
DIS885	R7508	C-CARBON R	RN72K1J-000JE	4723-000J+P-R	1
DIS885	R7527	C-CARBON R	RN72K1J-000JE	4723-000J+P-R	1
DIS885	R8001	C-CARBON R	RN72K1J-104JE	4723-104J+P-R	1
DIS885	R8009	C-CARBON R	RN72K1J-000JE	4723-000J+P-R	1
DIS885	R8014	C-CARBON R	RN72K1J-272JE	4723-272J+P-R	1
DIS885	R8017	C-CARBON R	RN72K1J-103JE	4723-103J+P-R	1

DIS885	R8018	C-CARBON R	RN72K1J-104JE	4723-104J+P-R	1
DIS885	R8019	C-CARBON R	RN72K1J-000JE	4723-000J+P-R	19/20 PAGE
DIS885	R8020	C-CARBON R	RN72K1J-331JE	4723-331J+P-R	1
DIS885	R8021	C-CARBON R	RN72K1J-331JE	4723-331J+P-R	1
DIS885	R8022	C-CARBON R	RN72K1J-391JE	4723-391J+P-R	1
DIS885	R8023	C-CARBON R	RN72K1J-471JE	4723-471J+P-R	1
DIS885	R8024	C-CARBON R	RN72K1J-821JE	4723-821J+P-R	1
DIS885	R8025	C-CARBON R	RN72K1J-102JE	4723-102J+P-R	1
DIS885	R8026	C-CARBON R	RN72K1J-182JE	4723-182J+P-R	1
DIS885	R8027	C-CARBON R	RN72K1J-392JE	4723-392J+P-R	1
DIS885	R8028	C-CARBON R	RN72K1J-333JE	4723-333J+P-R	1
DIS885	R8029	C-CARBON R	RN72K1J-000JE	4723-000J+P-R	1
DIS885	R8030	C-CARBON R	RN72K1J-103JE	4723-103J+P-R	1
DIS885	R8031	C-CARBON R	RN72K1J-222JE	4723-222J+P-R	1
DIS885	R8032	C-CARBON R	RN72K1J-222JE	4723-222J+P-R	1
DIS885	R8033	C-CARBON R	RN72K1J-103JE	4723-103J+P-R	1
DIS885	R8034	C-CARBON R	RN72K1J-273JE	4723-273J+P-R	1
DIS885	R8035	C-CARBON R	RN72K1J-821JE	4723-821J+P-R	1
DIS885	R8036	C-CARBON R	RN72K1J-391JE	4723-391J+P-R	1
DIS885	R8037	C-CARBON R	RN72K1J-471JE	4723-471J+P-R	1
DIS885	R8038	C-CARBON R	RN72K1J-821JE	4723-821J+P-R	1
DIS885	R8039	C-CARBON R	RN72K1J-102JE	4723-102J+P-R	1
DIS885	R8040	C-CARBON R	RN72K1J-272JE	4723-272J+P-R	1
DIS885	R8041	C-CARBON R	RN72K1J-272JE	4723-272J+P-R	1
DIS885	R8042	C-CARBON R	RN72K1J-471JE	4723-471J+P-R	1
DIS885	R8043	C-CARBON R	RN72K1J-272JE	4723-272J+P-R	1
DIS885	R8044	C-CARBON R	RN72K1J-471JE	4723-471J+P-R	1
DIS885	R8045	C-CARBON R	RN72K1J-471JE	4723-471J+P-R	1
DIS885	R8046	C-CARBON R	RN72K1J-391JE	4723-391J+P-R	1
DIS885	R8047	C-CARBON R	RN72K1J-471JE	4723-471J+P-R	1
DIS885	R8048	C-CARBON R	RN72K1J-471JE	4723-471J+P-R	1
DIS885	R8049	C-CARBON R	RN72K1J-272JE	4723-272J+P-R	1
DIS885	R8050	C-CARBON R	RN72K1J-391JE	4723-391J+P-R	1
DIS885	R8051	C-CARBON R	RN72K1J-471JE	4723-471J+P-R	1
DIS885	R8052	C-CARBON R	RN72K1J-821JE	4723-821J+P-R	1
DIS885	R8053	C-CARBON R	RN72K1J-101JE	4723-101J+P-R	1
DIS885	R8054	C-CARBON R	RN72K1J-332JE	4723-332J+P-R	1
DIS885	R8055	C-CARBON R	RN72K1J-101JE	4723-101J+P-R	1
DIS885	R8056	C-CARBON R	RN72K1J-561JE	4723-561J+P-R	1
DIS885	R8057	C-CARBON R	RN72K1J-561JE	4723-561J+P-R	1
DIS885	R8058	C-CARBON R	RN72K1J-471JE	4723-471J+P-R	1
DIS885	R8060	C-CARBON R	RN72K1J-103JE	4723-103J+P-R	1
DIS885	R8501	C-CARBON R	RN72K1J-000JE	4723-000J+P-R	1
DIS885	R8502	C-CARBON R	RN72K1J-000JE	4723-000J+P-R	1
DIS885	R8503	C-CARBON R	RN72K1J-000JE	4723-000J+P-R	1
DIS885	R8504	C-CARBON R	RN72K1J-000JE	4723-000J+P-R	1
DIS885	S7001	PUSH SW	NPS-111-S679	5200-4862+0-01	1
DIS885	S7002	PUSH SW	NPS-111-S679	5200-4862+0-01	1
DIS885	S7003	PUSH SW	NPS-111-S679	5200-4862+0-01	1
DIS885	S8010	PUSH SW	NPS-111-S681	5200-4861+0-01-*	1
DIS885	S8011	PUSH SW	NPS-111-S681	5200-4861+0-01-*	1
DIS885	S8012	PUSH SW	NPS-111-S681	5200-4861+0-01-*	1
DIS885	S8013	PUSH SW	NPS-111-S681	5200-4861+0-01-*	1
DIS885	S8014	PUSH SW	NPS-111-S681	5200-4861+0-01-*	1
DIS885	S8015	PUSH SW	NPS-111-S681	5200-4861+0-01-*	1
DIS885	S8016	PUSH SW	NPS-111-S681	5200-4861+0-01-*	1
DIS885	S8017	PUSH SW	NPS-111-S681	5200-4861+0-01-*	1

DIS885	S8018	PUSH SW	NPS-111-S681	5200-4861+0-01-*	1
DIS885	S8019	PUSH SW	NPS-111-S681	5200-4861+0-01-*	20/20 PAGE
DIS885	S8020	PUSH SW	NPS-111-S681	5200-4861+0-01-*	1
DIS885	S8021	PUSH SW	NPS-111-S681	5200-4861+0-01-*	1
DIS885	S8022	PUSH SW	NPS-111-S681	5200-4861+0-01-*	1
DIS885	S8023	PUSH SW	NPS-111-S681	5200-4861+0-01-*	1
DIS885	S8030	PUSH SW	NPS-111-S681	5200-4861+0-01-*	1
DIS885	S8031	PUSH SW	NPS-111-S681	5200-4861+0-01-*	1
DIS885	S8032	PUSH SW	NPS-111-S681	5200-4861+0-01-*	1
DIS885	S8033	PUSH SW	NPS-111-S681	5200-4861+0-01-*	1
DIS885	S8036	PUSH SW	NPS-111-S681	5200-4861+0-01-*	1
DIS885	X8001	CERA LOCK	CSTLS5M00G56-A0	2703-0922+0	1