

# ONKYO® SERVICE MANUAL

## DVD PLAYER MODEL DV-S501



UD	120V AC, 60Hz
UWT	120-240V AC, 50/60Hz

### SAFETY-RELATED COMPONENT WARNING!!

COMPONENTS IDENTIFIED BY MARK  $\triangle$  ON THE SCHEMATIC DIAGRAM AND IN THE PARTS LIST ARE CRITICAL FOR RISK OF FIRE AND ELECTRIC SHOCK. REPLACE THESE COMPONENTS WITH ONKYO PARTS WHOSE PART NUMBERS APPEAR AS SHOWN IN THIS MANUAL.

MAKE LEAKAGE-CURRENT OR RESISTANCE MEASUREMENTS TO DETERMINE THAT EXPOSED PARTS ARE ACCEPTABLY INSULATED FROM THE SUPPLY CIRCUIT BEFORE RETURNING THE APPLIANCE TO THE CUSTOMER.

**ONKYO®**  
**AUDIO COMPONENTS**

## OPERATING INSTRUCTIONS

### SAFETY PRECAUTIONS

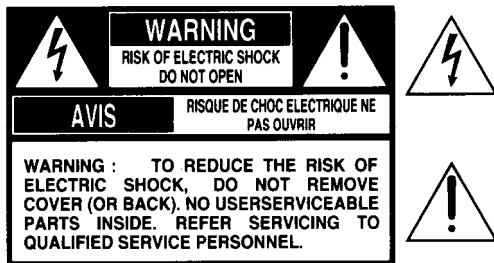

The lightning flash with arrowhead symbol, within an equilateral triangle, is intended to alert the user to the presence of uninsulated "dangerous voltage" within the product's enclosure that may be of sufficient magnitude to constitute a risk of electric shock to persons.

The exclamation point within an equilateral triangle is intended to alert the user to the presence of important operating and maintenance (servicing) instructions in the literature accompanying the appliance.

**WARNING:** TO REDUCE THE RISK OF FIRE OR ELECTRIC SHOCK, DO NOT EXPOSE THIS APPLIANCE TO RAIN OR MOISTURE. DANGEROUS HIGH VOLTAGES ARE PRESENT INSIDE THE ENCLOSURE. DO NOT OPEN THE CABINET. REFER SERVICING TO QUALIFIED PERSONNEL ONLY.

**CAUTION:** TO PREVENT ELECTRIC SHOCK, MATCH WIDE BLADE OF PLUG TO WIDE SLOT, FULLY INSERT.

**ATTENTION:** POUR EVITER LES CHOCS ELECTRIQUE, INTRODUIRE LA LAME LA PLUS LARGE DE LA FICHE DANS LA BORNE CORRESPONDANTE DE LA PRISE ET POUSSER JUSQU' AU FOND.

**CAUTION:** This Digital Video Disc Player employs a Laser System.  
To ensure proper use of this product, please read this owner's manual carefully and retain for future reference. Should the unit require maintenance, contact an authorized service location - see service procedure.

Use of controls, adjustments or the performance of procedures other than those specified may result herein hazardous radiation exposure.

To prevent direct exposure to laser beam, do not try to open the enclosure.  
Visible laser radiation when open and interlocks defeated.  
**DO NOT STARE INTO BEAM.**

## PREPARATION OF SERVICING

Pickup Head consists of a laser diode that is very susceptible to external static electricity.

Although it operates properly after replacement, if it was subject to electrostatic discharge during replacement, its life might be shortened. When replacing, use a conductive mat, soldering iron with ground wire, etc. to protect the laser diode from damage by static electricity.

BLOCK DIAGRAM (UD)

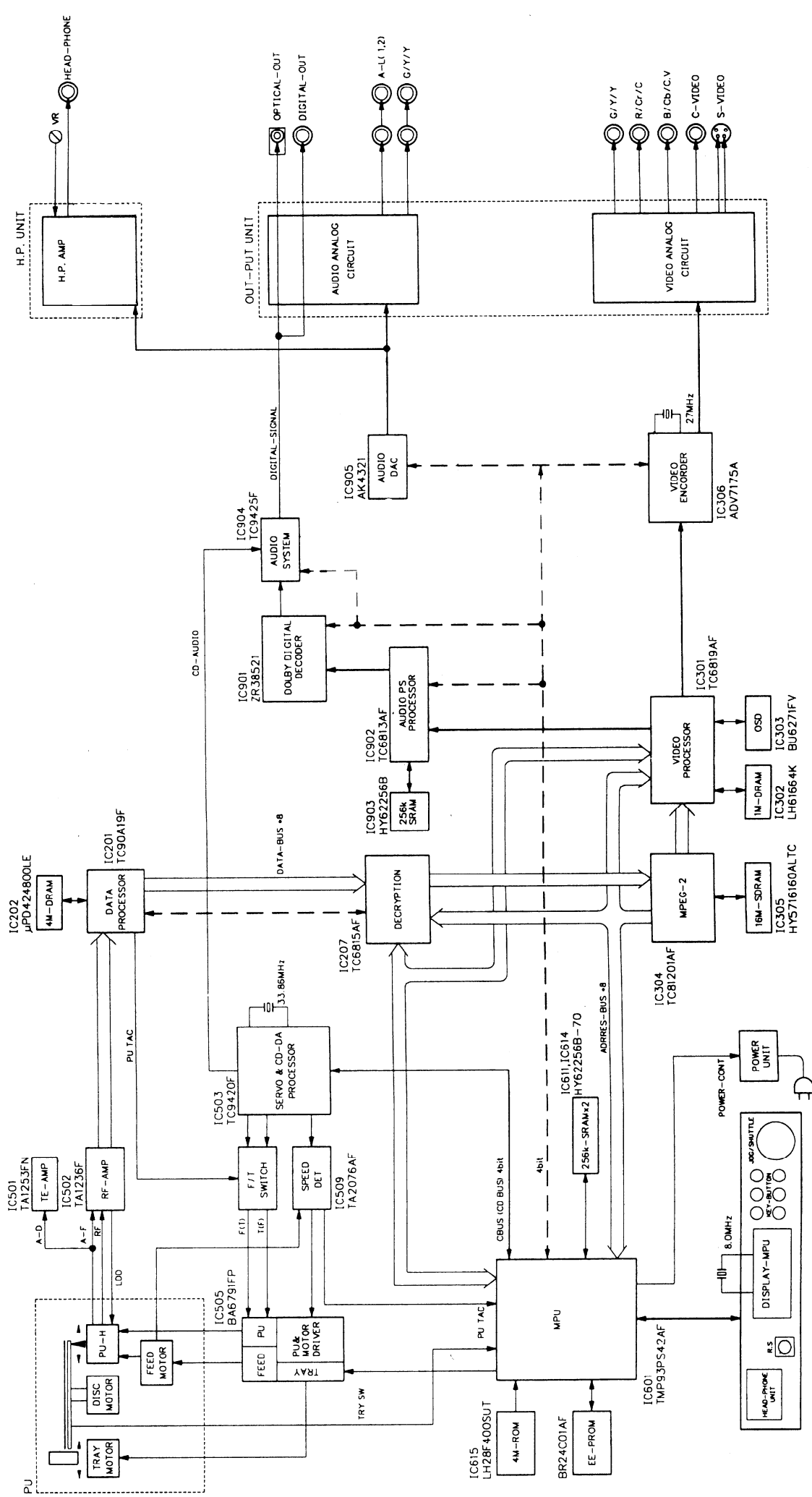

BLOCK DIAGRAM (WT)

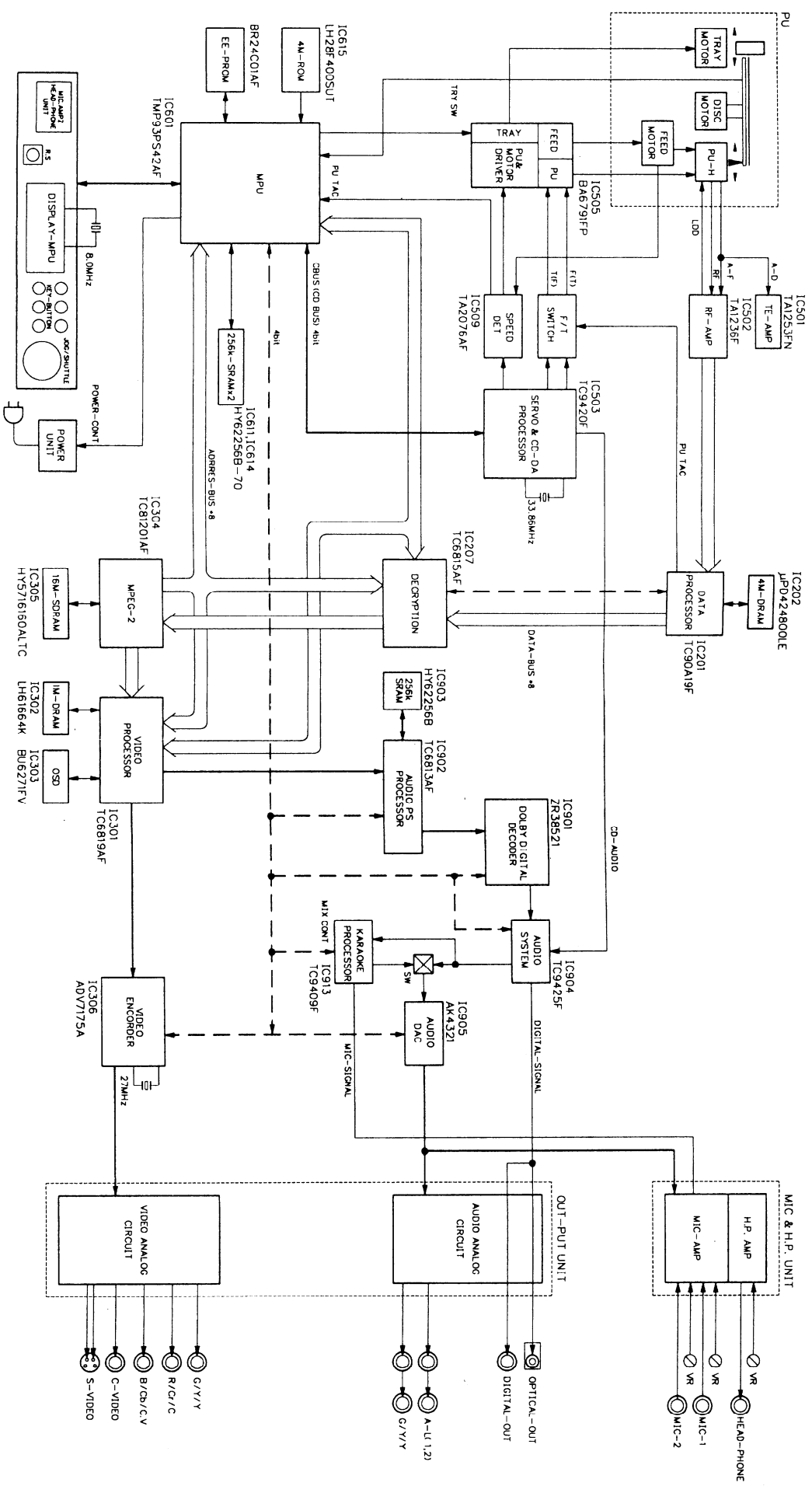

EXPLODED VIEW (UD),(120V-240V,AC)

- 7 -

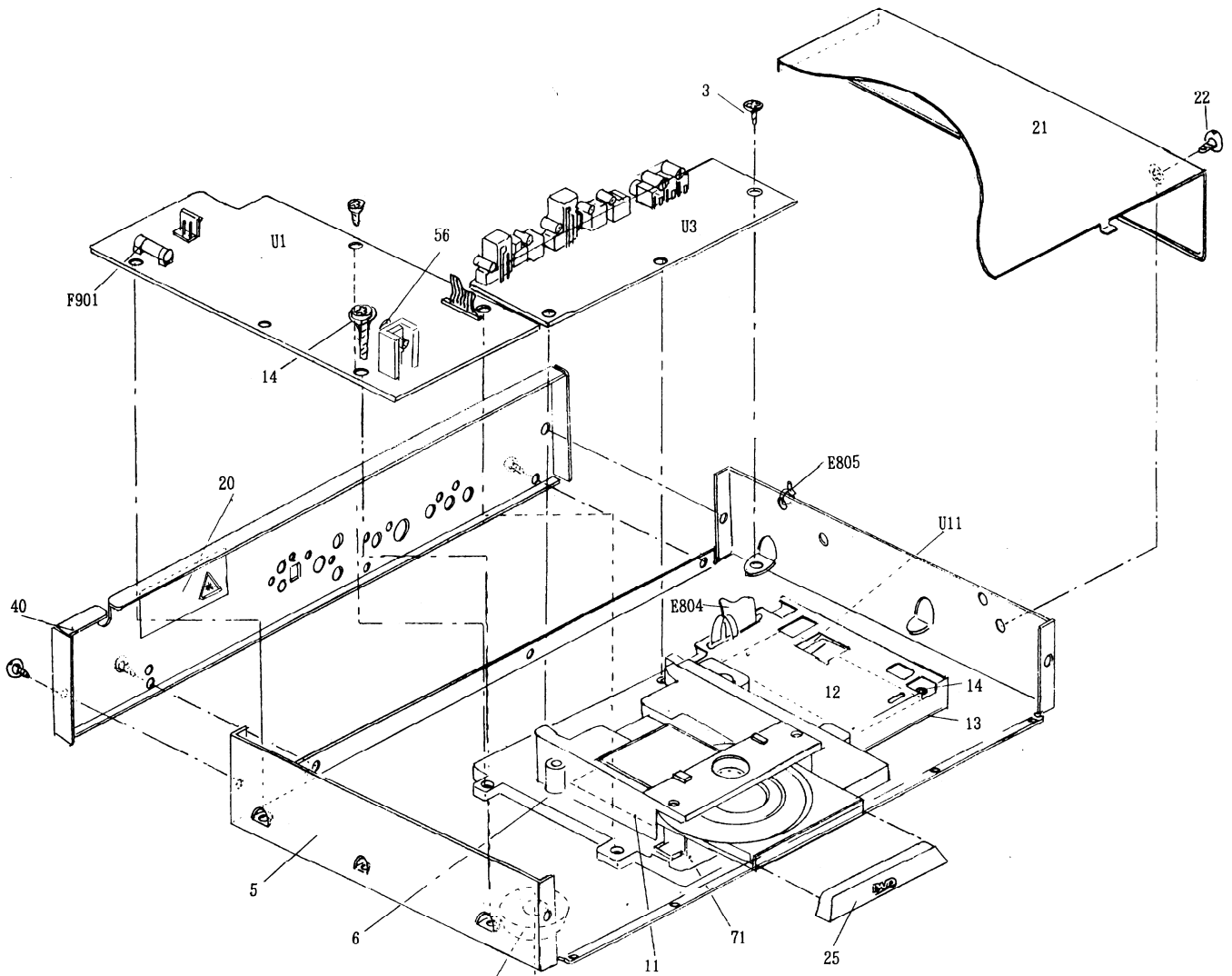

- 8 -

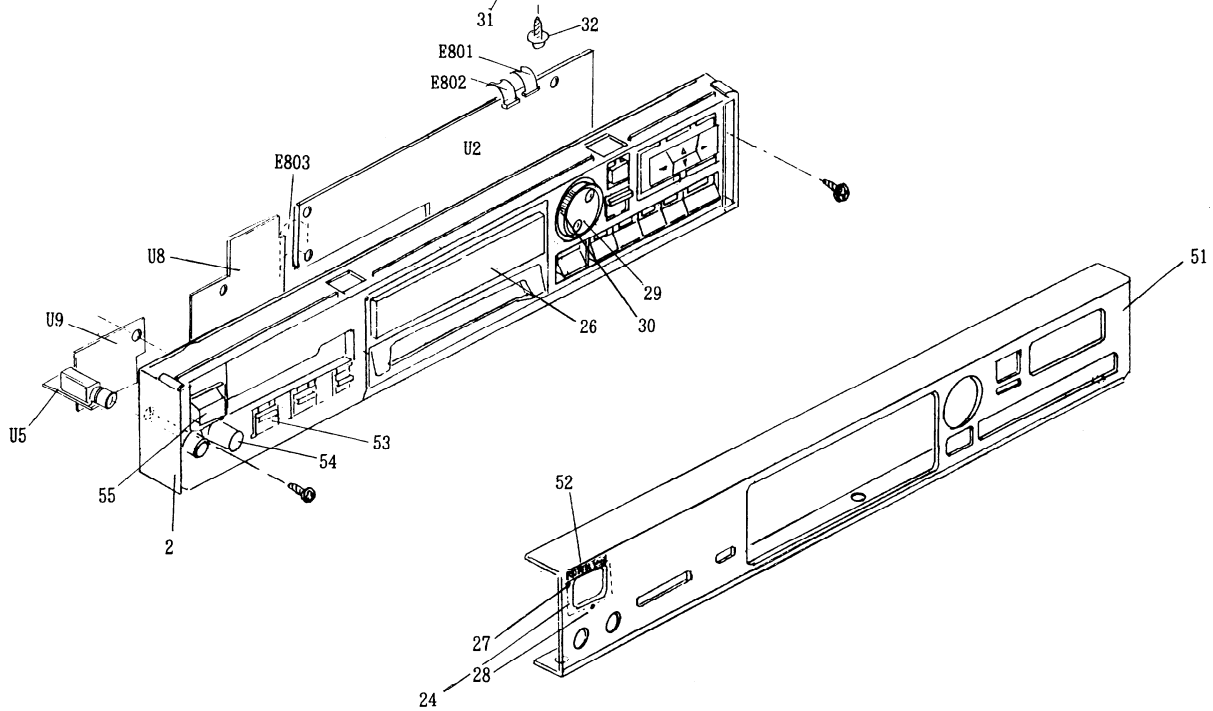

# EXPLODED VIEW (WT)

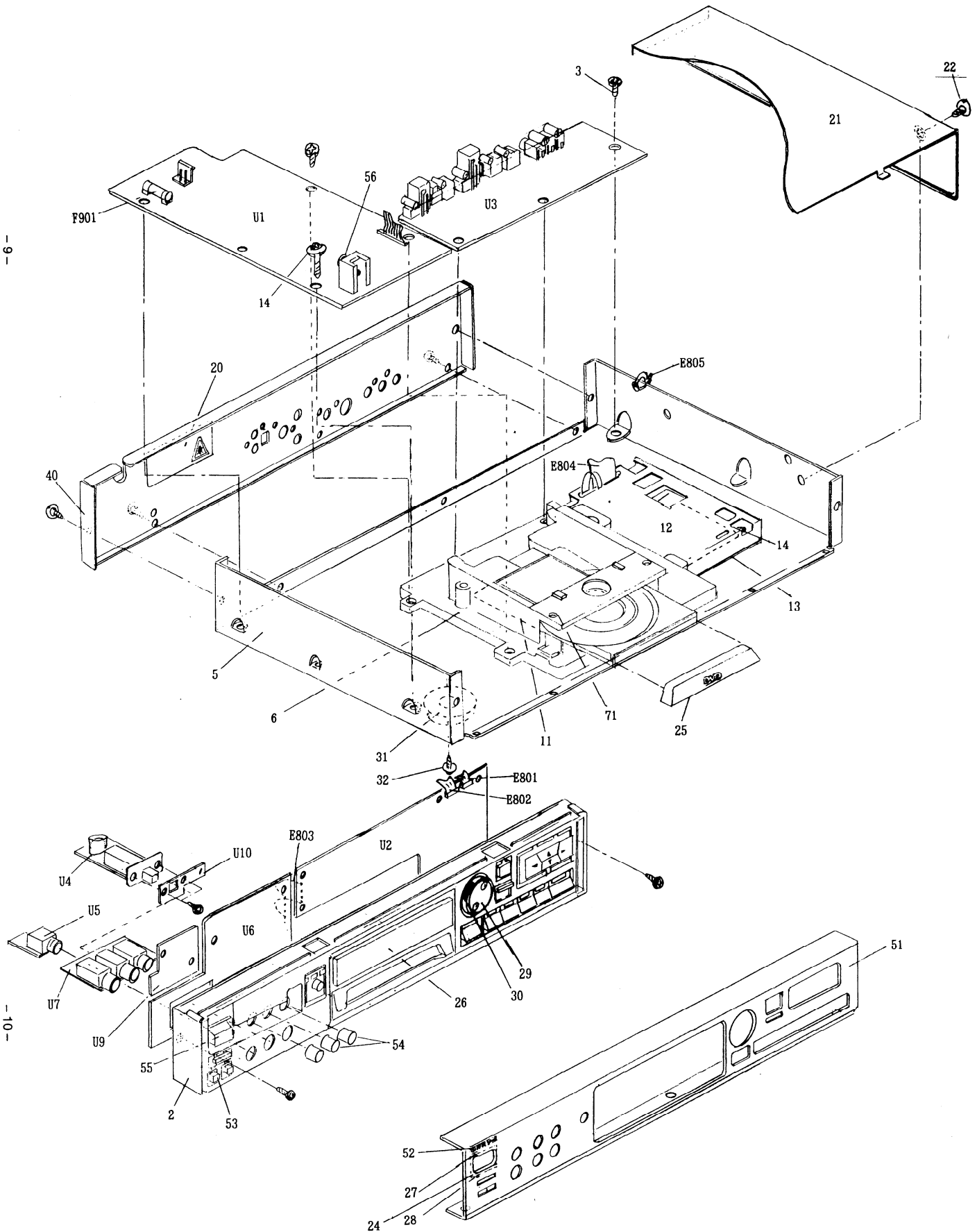

- 6 -

- 10 -

DV-S301 DV-S301

## PARTS LIST

REF. NO.	PART NO.	DESCRIPTION	REF. NO.	PART NO.	DESCRIPTION
2	27111071A	Front bracket <B>	E801	2045101512	NCFC5-101512, Flat cable
	27111072A	Front bracket <G>	E802	2045102512	NCFC5-102512, Flat cable
3	838130088	3TTB+8B, Self-tapping screw	E803	2045131012	NCFC5-131012, Flat cable
5	27100363	Chassis	E804	2045251012	NCFC5-251012, Flat cable
6	27191047A	Holder M	E805	260208	Wire tie
9	27300750	Bushing, cord	F901	252146	1. 25A-TSC, Primary fuse <D>
11	27191049	Holder PC		252071	1. 25A-SE-EAWK, Primary fuse <T/WX>
12	27225138	Shield case U	P950		AS-UC-6#18 (SPT-2), Power supply cord <D>
13	27225139	Shield case B		253193HIT	AS-CEE, Power supply cord <T/WX>
14	831130168	3TTW+16B, Self-tapping screw	U1	IH386546-1A	NAPS-6346-1A, Power supply circuit pc board ass'y <D>
20	29362285	Label		IH386546-1B	NAPS-6346-1B, Power supply circuit pc board ass'y <T>
21	28184697Z	Top cover <B>	U2	IH386547-1A	NAPS-6346-1C, Power supply circuit pc board ass'y <WX>
	28184696Z	Top cover <G>		IH386547-1B	NADIS-6347-1A, Display circuit pc board ass'y <D>
22	838430088	3TTB+8B (BC), Self-tapping screw <B>	U3	IH386547-1C	NADIS-6347-1B, Display circuit pc board ass'y <T>
	838230088	3TTB+8B (Ni), Self-tapping screw		IH386548-1A	NADIS-6347-1C, Display circuit pc board ass'y <WX>
24	27267993	Guide, Power <B>	U4	IH386548-1B	NAAF-6348-1A, pc board ass'y <D>
	27267994	Guide, Power <G>		IH386548-1C	NAAF-6348-1B, pc board ass'y <T>
25	28148399	Door <B>	U5	IH386548-1C	NAAF-6348-1C, pc board ass'y <WX>
	28148400	Door <G>		IH386549-1B	NASW-6349-1B, switch pc board ass'y <T>
26	28191829	Clear plate <B>	U6	IH386550-1A	NAAF-6350-1A, pc board ass'y <D>
	28191830	Clear plate <G>		IH386550-1C	NAAF-6350-1C, pc board ass'y <WX>
27	28198778	Facet	U7	IH386551-1B	NAAF-6351-1B, pc board ass'y <T>
28	28198846	Facet 3	U8	IH386552-1B	NAAF-6352-1B, pc board ass'y <T>
29	28325353A	Knob, Jog <B>		IH386553-1A	NAAF-6353-1A, pc board ass'y <D>
	28325601	Knob, Jog <G>		IH386553-1C	NAAF-6353-1C, pc board ass'y <WX>
30	28325352A	Knob S <B>	U9	IH386554-1A	NAAF-6354-1A, pc board ass'y <D>
	28325600	Knob S <G>		IH386554-1B	NAAF-6354-1B, pc board ass'y <T>
31	27175311A	Leg		IH386554-1C	NAAF-6354-1C, pc board ass'y <WX>
32	831430088	3TTW+8B (BC), Self-tapping screw	U10	IH386555-1B	NAAF-6355-1B, pc board ass'y <T>
40	27122468	Rear panel <D>	U11	24150002	SD-3100K1-ZN, Main circuit pc board ass'y <D/WX>
	27122469	Rear panel <T>		24150001	SD-3100K2-ZP, Main circuit pc board ass'y <T>
	27122470	Rear panel <WX>			
51	27212005	Front panel <D/WX>			
	27212006A	Front panel <T>			
	27212007A	Front panel <G>			
52	28135244	Badge <B>			
	28135245	Badge <G>			
53	28325598	Knob 3 <D/WX>			
	28325596	Knob 2 <T>			
	28325597	Knob 2 <G>			
54	28325452	Knob, Mic. <B>			
	28325495	Knob, Mic. <G>			
55	28325497A	Knob, power <B>			
	28325499A	Knob, power <G>			
56	838430107	3TTB+10S (BC), Self-tapping screw			
71	24801001	SD-2100K1-ZX, DVD mechanism ass'y			

**Q701: MICROPROCESSOR TERMINAL FUNCTION**

PIN No.	PORT NAME	I/O	DESCRIPTION	PIN No.	PORT NAME	I/O	DESCRIPTION
1	KEY1	I		33	P1	O	Output port for fluorescent tube (segment)
2	KEY2	I	Key input terminal	34	P2	O	
3	KEY3	I		35	P3	O	
4	KEY4	I		36	P4	O	
5	MODE1	I	L:Effective the ONKYO-remote control	37	P5	O	
6	MODE2	I	GND (Select the version)	38	P6	O	
7	MONITOR	O	Monitor terminal	39	P7	O	
8	SCK	I	Serial clock input port	40	P8	O	
9	SOUT	O	Serial data output port	41	P9	O	
10	SIN	I	Serial data input port	42	P10	O	
11	BUZZER	O	Output port for buzzer	43	P11	O	
12	RI.OUT	O	Output port for system(output)	44	P12	O	
13	RI.IN	I	Output port for system(input)	45	P13	O	
14	SPDVD	O	Control port for KARAOKE processor	46	P14	O	
15	SPLON	O	Control port for KARAOKE processor	47	P15	O	
16	-		Not use	48	P16	O	
17	REMO	I	Remote control input port	49	-		Not use
18	FSTBX	I	Serial data transmit input port	50	6G	O	Output port for fluorescent tube (grid)
19	RESET	I	Reset signal input	51	5G	O	
20	JOG2	I	JOG plus input	52	4G	O	
21	JOG1	I		53	3G	O	
22	ZIN	I	Clock circuit (input)	54	2G	O	
23	XOUT	O	Clock circuit (output)	55	1G	O	
24	Vss		Ground	56	FL_ON/OFF	O	Fluorescent tube control port (heater)
25	SHUTTLE1	I	Shuttle input	57	VCC		Power supply
26	SHUTTLE2	I		58	VEE		Power supply for fluorescent tube
27	SHUTTLE3	I		59	AVSS		Ground for A/D converter
28	SHUTTLE4	I		60	VREF		Regulated power supply for A/D converter
29	-		Not use	61	POWER_LED	O	Control terminal of power LED
30	-			62	STANDBY_LED	O	Control terminal of standby LED
31	-			63	TEST		(+5V)
32	-			64	-		Not use

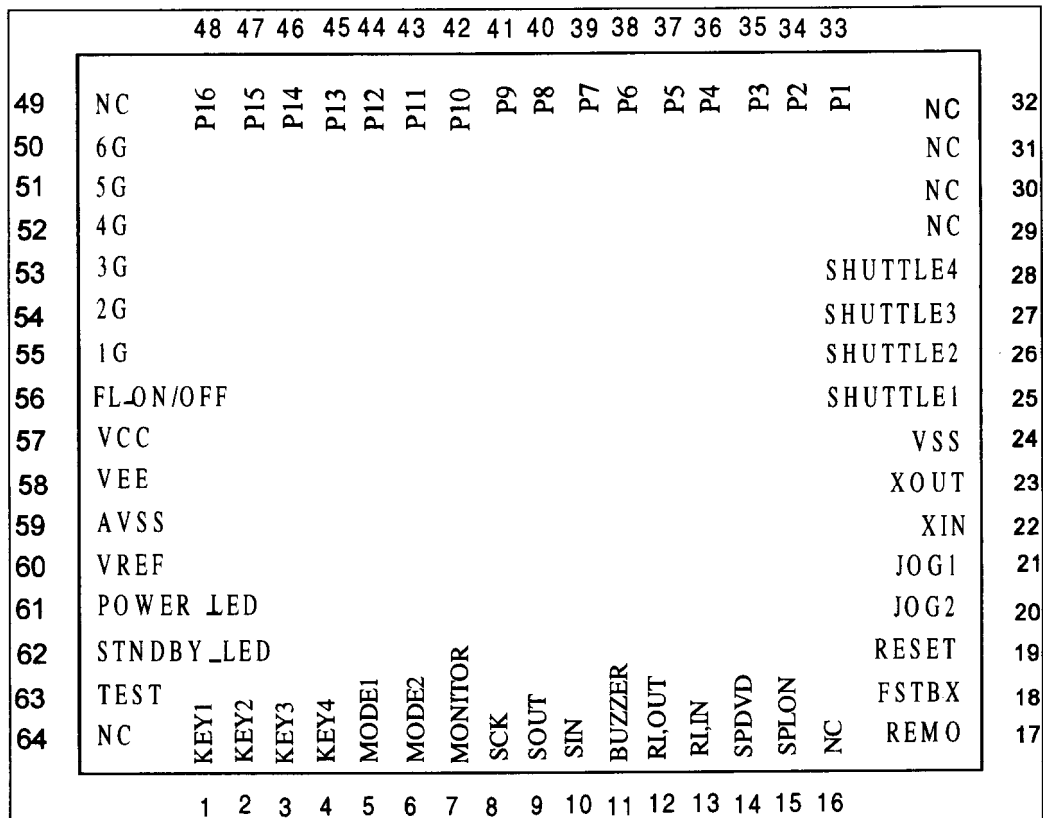



**PARTS LIST**

REF. No.	PART No.	DESCRIPTION	REF. No.	* <D>: USA, <T>: ASIA, <WT>: PX Version	DESCRIPTION
U1	1H386546-1A	NAPS-6346-1A, Power supply circuit pc board ass'y <D>	N Q907	24120044	ON3131-R (PHOTO CPL)
	1H386546-1B	NAPS-6346-1B, Power supply circuit pc board ass'y <T>	N		
	1H386546-1C	NAPS-6346-1C, Power supply circuit pc board ass'y <WX>	N Q403-Q406		<b>TRANSISTOR</b> 2211706 or 2211705 2SD655-F or 2SD655-E 2213570 or 221281 or 2214930 RN1207 or DTC114YS or UN4214
U2	1H386547-1A	NADIS-6347-1A, Display circuit pc board ass'y <D>	N Q407, Q710, Q711		
	1H386547-1B	NADIS-6347-1B, Display circuit pc board ass'y <T>	N Q408, Q704		DTA124ES
	1H386547-1C	NADIS-6347-1C, Display circuit pc board ass'y <WX>	N Q702		2212600 2211504 or 2211503 2SA950-Y or 2SA950-0
U3	1H386548-1A	NAAF-6348-1A, pc board ass'y <D>	N Q703		212189 6-BT-289GK (FL TUBE) N
	1H386548-1B	NAAF-6348-1B, pc board ass'y <T>	N Q705		24130011 PIC-12043TE2 (REMTE SENS)
	1H386548-1C	NAAF-6348-1C, pc board ass'y <WX>	N Q706		3010309 PKM13EPY-4002 (PIEZO) N
U4	1H386549-1B	NASW-6349-1B, switch pc board ass'y <T>	N Q712-Q713		2212794 2SD1468-R<D><WX>
U5	1H386550-1A	NAAF-6350-1A, pc board ass'y <D>	N Q715		2213570 or 221281 or 2214930 RN1207 or DTC114YS or UN4214<D><WX>
	1H386550-1C	NAAF-6350-1C, pc board ass'y <WX>	N Q716		2212600 DTA124ES<D><WX>
U6	1H386551-1B	NAAF-6351-1B, pc board ass'y <T>	N Q801, Q802		2212794 2SD1468-R<T>
U7	1H386552-1B	NAAF-6352-1B, pc board ass'y <T>	N Q804		2213570 or 221281 or 2214930 RN1207 or DTC114YS or UN4214<T>
U8	1H386553-1A	NAAF-6353-1A, pc board ass'y <D>	N Q805		2212600 DTA124ES<T>
	1H386553-1C	NAAF-6353-1C, pc board ass'y <WX>	N Q906		2211504 or 2211503 2SA950-Y or 2SA950-0
U9	1H386554-1A	NAAF-6354-1A, pc board ass'y <D>	N Q910		2201285 2SD882-Q
	1H386554-1B	NAAF-6354-1B, pc board ass'y <T>	N Q911		2201275 2SB772-Q
	1H386554-1C	NAAF-6354-1C, pc board ass'y <WX>	N Q912		2213284 or 2211183 or 2214281 2SC1740S-R or 2SC1740-R or 2SD2144S-U
U10	1H386555-1B	NAAF-6355-1B, pc board ass'y <T>	N Q913		2213354 or 2211455 or 2213074 2SA933S-R or 2SA1015-GR or 2SA933-R
U11	24150002	SD-3100K1-ZN, Main circuit pc board ass'y <D><WX>	N Q914		2213570 or 221281 or 2214930 RN1207 or DTC114YS or UN4214
	24150001	SD-3100K2-ZP, Main circuit pc board ass'y <T>	N Q915, Q916		2211945 or 2212305 2SK246-GR or 2SK381-E
	<b>Ics</b>				<b>DIODE</b>
Q204	22241228R9 or 22241228R2	TC74HC4053FP or TC74HC4053FP	N D201, D202, D701		223205 or 223163 1SS270A or 1SS133
Q301	222755	74HC004P (TC74HC004P)	D702		224470562 MTZJ5. 6B
Q302	24120038	GP1F32T (PHOTO CPL)	D703, D704		225364 SEL4914D N
Q401	22240191	NJM4565D-D	D901-D904		22380287F EM2A N
Q601	22241234	BA3313L<T>	D905		22380291 EGO1C N
Q602	222654	NJM4556D<T>	D906-D908, D913		22380294 AGO1Z N
Q701	22241227R3 or 22241252R3	M38123M4-127FP or M38127ECFP (DV-S501)	N D909		22380295F RN2Z N
Q714	222654	NJM4556D<D><WX>	D910, D911		22380296F RK46 N
Q217-Q219	2213354 or 2211455 or 2213074	2SA933S-R or 2SA1015-GR or 2SA933-R	D912		22380297 EU01 N
Q201, Q202, Q203	2213354 or 2211455 or 2213074	2SA933S-R or 2SA1015-GR or 2SA933-R	D917		22380300 RU2YX N
Q205-Q216	2213284 or 2211183 or 2214281	2SC1740S-R or 2SC1740-R or 2SD2144S-U	D923		224472204 MTZJ22D
Q803	222956	NJM2068D-D<T>	D924		224470332 MTZJ3. 3B
Q901	22241229	STR-F6653	N D930, D931, D932, D934		22380260 or 22380032 or 22380035 RL1N4003 or 1SR139-100 or GP104003E
Q901A	27160412	RAD-111	N D935, D936		224470753 MTZJ7. 5C
Q905	22241233	SE005N	N		<b>CAPACITOR</b>
Q902	22241230	S13090C	N C202, C203, C205		354744709 47 μF, 16V, Elect.
Q903	22241231	S13050C	N C207, C208, C209, C302		C303, C211, C212, C214 100 μF, 6. 3V, Elect.
Q904	22241232	S13033C	N C305-CC308		345022204 CC45SL50V-220J
Q901B, Q902B, Q903B, Q904B	838430107	3TTB+10S (BC)	C309, C950, C951		374721044 0. 1 μF ± 5%, 50V, Plastic
Q902A, Q903A, Q904A	27160145-1	RAD-51 (RADIATOR)	C401, C402		374722224 2200pF ± 5%, 50V, Plastic

## PARTS LIST

REF. No.	PART No.	DESCRIPTION	REF. No.	PART No.	DESCRIPTION	
C403, C404	345023314	CC45SL50V-331J	E105	25136350	NCAF-6350<D>	N
C405, C406	374724724	4700pF ± 5%, 50V, Plastic	E106	25136353	NCAF-6353<D>	N
C407, C408, C411, C412, C701, C702	354782209	22 μF, 50V, Elect.	E107	25136349	NCSW-6349<T>	N
C415, C703	354724719	100 μF, 6. 3V, Elect.	E108	25136351	NCAF-6351<T>	N
C415 or	393724717	470 μF, 6. 3V, Elect.	E109	25136352	NCAF-6352<T>	N
C416	374721024	1000pF ± 5%, 50V, Plastic	N E110	25136355	NCAF-6355<T>	N
C420, C421, C937, C954, C955, C958, C959	354741019	100 μF, 16V, Elect.	E201, E203	27190540-1	HOLDER (CLAMP)	
C601, C602	374723334	0. 033 μF ± 5%, 50V, Plastic<T>	E202, E901	25065425	NEGITANSI M3	
C603, C604, C605	354741009	10 μF, 16V, Elect. <T>	E701	27191048A	(FL)	N
C606, C607	354744709	47 μF, 16V, Elect.<T>	E805	260208	Wire Tie	
C720-C721	354744709	47 μF, 16V, Elect. <D>	F901A, F901B	25050065	△YSH403T Fuse holder	
C725-						
C726, C801, C802	354782209	22 μF, 50V, Elect. <D>				
C803, C804	374721034	0. 01 μF ± 5%, 50V, Plastic<T>	L201, L202, L904-L606	231253K100	NCH-1490	N
C805, C806	354744709	47 μF, 16V, Elect. <T>	L901	231280	NCH-3561	N
C807-C809	354782209	22 μF, 50V, Elect. <T>	L902	231222	NCH-3454	
C901-C904, C916	3500077	4700pF ± 20%, 50V, Plastic	L903	230906	BL02RN2-R62	
C910	3937E1017S	100 μF, 400V, Elect.				
C911	3000115	DE1005SL-221J2K				
C912	3000114	QXJ2J-103K-TPT	N P201	25045546	NPJ-3PDRE367	N
C913	354764709	47 μF, 35V, Elect.	N P202	25051750	NSCT-4P1537	
C914	345024714	CC45SL50V-471J	P203	25045547	NPJ-1PDYE368	N
C915	335321025	CK45B50V-102K	P210A	25051949	NSCT-25P1736	N
C920	393751027S	1000 μF, 25V, Elect.	P301	25045548	NPJ-1PDOR369	N
C921, C922, C931	393744717	470 μF, 16V, Elect.	N P310	25045330 or 25045481	NPJ-2PDBL184 or NPJ-2PDBL299	
C923, C924, C932- C934, C938, C926, C927, C930, C936	354782209	22 μF, 50V, Elect.	N P401	25045371	NPJ-2PDWR214	
C925, C928	393741027S	1000 μF, 16V, Elect.	P410A	25055149	NPLG-5P133	
C929	374722244	0. 22 μF ± 5%, 50V, Plastic	N P410B	2002391060	NSAS-10P0664	N
C935	335622230	CK45F50V-223Z	P601, P602	25045545	YKB26-5814<T>	N
C952, C953	354761029S	1000 μF, 35V, Elect.	P603	25045443 or 25045561	YKB26-5803 or YKB26-5807<T>	N
C956, C957	374721034	0. 01 μF ± 5%, 50V, Plastic	P610	27190608-1	(CLAMP) UA-0 V0<T>	
C961	374722244	0. 22 μF ± 5%, 50V, Plastic	P701	25045441 or 25045560	YKB26-5801 or YKB26-5805 <D><WX>	N
C990	3500191	DE7150F-103M<T>	P710A	25052122R2	NSCT-13P2020	N
C991A	27301216	SB1925A<T>	P710B	25051895	NSCT-13P1682<D><WX><T>	N
	RESISTOR		P711A	25055153	NPLG-9P137<T>	
R764	5132436	N14RGL20KA17Z<D><WX>	P711B	2002391815	NSAS-18P0666<T>	N
R800	5132436	N14RGL20KA17Z<T>	N P712, P713	25051892	NSCT-10P1679	N
R801, R802	5121437	N11RHL50KA17Z<T>	P714A, P714B, P714B, P714C	25051089	NSCT-5P876	
R901	4000076	MPC74-5WK-0. 22	N P715A, P715A	25051107	NSCT-3P894<D>	
R902	411516844	RI/2J-680K	P715B, P715B	25050267	NSCT-3P95<D>	
R903	441726834NF	68kΩ ± 5%, 2W, Metal	N P910A	25055147	NPLG-3P131	
R904	441721044NF	100kΩ ± 5%, 2W, Metal	P910B	2002390615	NSAS-6P0588	N
R905	453530224	2. 2Ω ± 5%, 1/2W, Metal	P911	2002392830	NSAS-28P0663	N
R906	443522724	2. 7kΩ ± 5%, 1/2W, Metal	P950A	25055675	NPLG-2P631	
R907	451735194F	0. 51Ω ± 5%, 2W, Metal				
R908	443526814	680Ω ± 5%, 1/2W, Metal	N T901	2301342	△NPT-1341	N
R909	443523324	3. 3kΩ ± 5%, 1/2W, Metal	T902	2301343	△NPT-1342D (120V/60Hz)	N
R912	443522214	220Ω ± 5%, 1/2W, Metal				
R913	443521024	1kΩ ± 5%, 1/2W, Metal	X701	3010190	CST8. 00MTW	
R919	443522234	22kΩ ± 5%, 1/2W, Metal	F901	252146	△1. 25A-TSC. Primary fuse <D>	
	SWITCH			252071	△1. 25A-SE-EAWK. fuse <T>/<WX>	
S701-S712, S716	25035652	NPS-111-S604				
S713	25035652	NPS-111-S604<WX>	P950	253192HIT	△AS-UC-6*18 (SPT-2). Power cord <D>	
S714, S715	25035652	NPS-111-S604<D><WX>	P950	253193HIT	△AS-CEE. Power supply cord <T>/<WX>	
S717	25065514	SRGPHJ-A-2-1 (Jogshuttle)				
S801-S803	25035652	NPS-111-S604<T>	E910	29361580	T1. 25AL250V<T><WX>	
S991	25035636	NPS-111-L590P<T>	E910	29362309	1. 25A/125V<D>	N
	HOLDER		Z201-Z204	3030040	H286LAI5-15674 LC Block	N
E101	25136346A	NCPS-6346	N E801	2045101512	NCFC5-101512. Flat cable	
E102	25136347	NCDS-6347	N E802	2045102512	NCFC5-102512. Flat cable	
E103	25136348	NCAF-6348	N E803	2045131012	NCFC5-131012. Flat cable	
E104	25136354	NCAF-6354	N E804	2045251012	NCFC5-251012. Flat cable	

**DVD MECHA. CONTROL PC BOARD PARTSLIST (UD)**

REF.No	PART No	DESCRIPTION	REMARK	REF.No	PART No	DESCRIPTION	REMARK
	<b>24150001 COMPLETE PCB ASSY SD-3100K2-ZP</b>						
IC504,IC511,IC512,IC516,IC608,IC909,IC920	79040006	IC	TC7S04F	IC908,IC912,IC914	79040057	IC	TC74HC257AF
IC607	79040007	IC	TC7S08F	IC911	79040059	IC	TC74HC393AF
IC309,IC520,IC910,IC916,IC917	79040008	IC	TC7S32F	IC306	79040060	IC	ADV7175AKS
IC519,IC521	79040009	IC	TC7S86F	IC202	79040061	IC	UPD424800LE-70
IC307,IC522	79040011	IC	TC7W04F	IC611,IC614,IC903	79040062	IC	HY62256ALJ-70-TR
IC523,IC906	79040013	IC	TC7W74F	IC305	79040063	IC	HY57V16160ATC-10 or MB811171622A-100FN
IC517	79040014	IC	TA75S01F	IC615	79040064	IC	LH28F400SUT-NF8
IC509	79040016	IC	TA2076AF	IC203	79040066	IC	UPC29L33T
IC502	79040017	IC	TA1236F	IC915	79040068	IC	BA17805FP-E2
IC501	79040018	IC	TA1253FN	IC613	79040070	IC	S-24C01AFJ-TB
IC201	79040020	IC	TC90A19F	IC302	79040071	IC	LH61664AK-60
IC503	79040021	IC	TC9420F	IC508	79040072	IC	TC7S66F(TE85L)
IC904	79040022	IC	TC9425F	IC907,IC918,IC919	79040073	IC	TC4W53F
IC606	79040027	IC	TC74HC32AF	IC207	79040080	IC	TC6815AF(Z)
IC506	79040029	IC	TC74HC4053AF	IC303	79040084	IC	BU6291FV
IC604,IC609	79040030	IC	TC74AC573F	IC301	79040086	IC	TC6341AF(Z)
IC505	79040036	IC	BA6791FP	IC601	79040099	IC	TMP93CS42AF-9404
IC507	79040039	IC	NJM3403AMC	Q601	79050001	TRANSISTOR,CHIP	RN2402
IC510	79040040	IC	BA6844AFP	Q505	79050009	TRANSISTOR,CHIP	RN1401
IC602	79040041	IC	PST591-DMT	Q502	79050010	TRANSISTOR,CHIP	RN1411
IC901	79040043	IC	ZR38521	Q504	79050014	TRANSISTOR,CHIP	HN1C03F
IC905	79040047	IC	AK4321	Q503,Q506	79050015	TRANSISTOR,CHIP	HN1B01F
IC518	79040050	IC	NJM2107F	Q501	79050019	TRANSISTOR,CHIP	2SA1182
IC304	79040052	IC	TC81201AF	Q301,Q302	79050022	TRANSISTOR,CHIP	HN1A01F-Y(TE85L)
IC913	79040053	IC	TC9409BF-001	D501,D503	79060018	DIODE	1SS193(TE85L)
IC902	79040056	IC	TC6813AF(Z)	X301	79080013	OSCILLATOR	SMD49-27MHZ
				X501	79080014	OSCILLATOR	SMD49-33.86MHZ
				X601	79080015	OSCILLATOR	CSACV20.00MX040
				W501	79080020	CABLE,FLEXIBLE	FFC-21P-L292
				W502	79080021	CABLE,FLEXIBLE	FFC-19P-L185
				W301	79080022	CABLE,FLEXIBLE	FFC-25P-1.0MM

DVD MECHA. CONTROL PC BOARD PARTSLIST (WT)

REF.No	PART No	DESCRIPTION	REMARK	REF.No	PART No	DESCRIPTION	REMARK
IC504,IC511,IC512,IC516,IC608,IC909,IC920	24150002	COMPLETE PCB ASSY	SD-3100K1-ZN				
IC607	79040006 IC		TC7S04F	IC911	79040059 IC		TC74HC393AF
IC309,IC520,IC910,IC916,IC917	79040007 IC		TC7S08F	IC306	79040060 IC		ADV7175AKS
IC519,IC521	79040008 IC		TC7S32F	IC202	79040061 IC		UPD424800LE-70
IC307,IC522	79040009 IC		TC7S86F	IC611,IC614,IC903	79040062 IC		HY62256ALJ-70-TR
IC523,IC906	79040011 IC		TC7W04F	IC305	79040063 IC		HY57V16160ATC-10
IC517	79040013 IC		TC7W74F	IC615	79040064 IC		LH28F400SUT-NF8
IC509	79040014 IC		TA75S01F	IC203	79040066 IC		UPC29L33T
IC502	79040016 IC		TA2076AF	IC915	79040068 IC		BA17805FP-E2
IC501	79040017 IC		TA1236F	IC613	79040070 IC		S-24C01AFI-TB
IC201	79040018 IC		TA1253FN	IC302	79040071 IC		LH61664AK-60
IC503	79040020 IC		TC90A19F	IC508	79040072 IC		TC7S66F(TB85L)
IC904	79040021 IC		TC9420F	IC907,IC918,IC919	79040073 IC		TC4W53F
IC606	79040022 IC		TC9425F	IC303	79040078 IC		BU6272FV-E2
IC506	79040027 IC		TC74HC32AF	IC207	79040080 IC		TC6815AF(Z)
IC604,IC609	79040029 IC		TC74HC4053AF	IC301	79040086 IC		TC6341AF(Z)
IC505	79040030 IC		TC74AC573F	IC601	79040099 IC		TMP93CS42AF-9404
IC507	79040036 IC		BA6791FP	Q601	79050001 IC		RN2402
IC510	79040039 IC		NJM3403AMC	Q505	79050009 IC	TRANSISTOR,CHIP	RN1401
IC602	79040040 IC		BA6844AFP	Q502	79050010 IC	TRANSISTOR,CHIP	RN1411
IC901	79040041 IC		PST591-DMT	Q504	79050014 IC	TRANSISTOR,CHIP	HN1C03F
IC905	79040043 IC		ZR38521	Q503,Q506	79050015 IC	TRANSISTOR,CHIP	HN1B01F
IC518	79040047 IC		AK4321	Q501	79050019 IC	TRANSISTOR,CHIP	2SA1182
IC304	79040050 IC		NJM2107F	Q301,Q302	79050022 IC	TRANSISTOR,CHIP	HN1A01F-Y(TB85L)
IC902	79040052 IC		TC81201AF	D501,D503	79060018 IC	DIODE	1SS193(TB85L)
IC908,IC912	79040056 IC		TC6813AF(Z)	X301	79080013 IC	OSCILLATOR	SMD49-27MHZ
	79040057 IC		TC74HC257AF	X501	79080014 IC	OSCILLATOR	SMD49-33.86MHZ
				X601	79080015 IC	OSCILLATOR	CSACV20.00MX040
				W301	79080022 IC	CABLE,FLEXIBLE	FFC-25P-1.0MM

# Mechanism Assembly

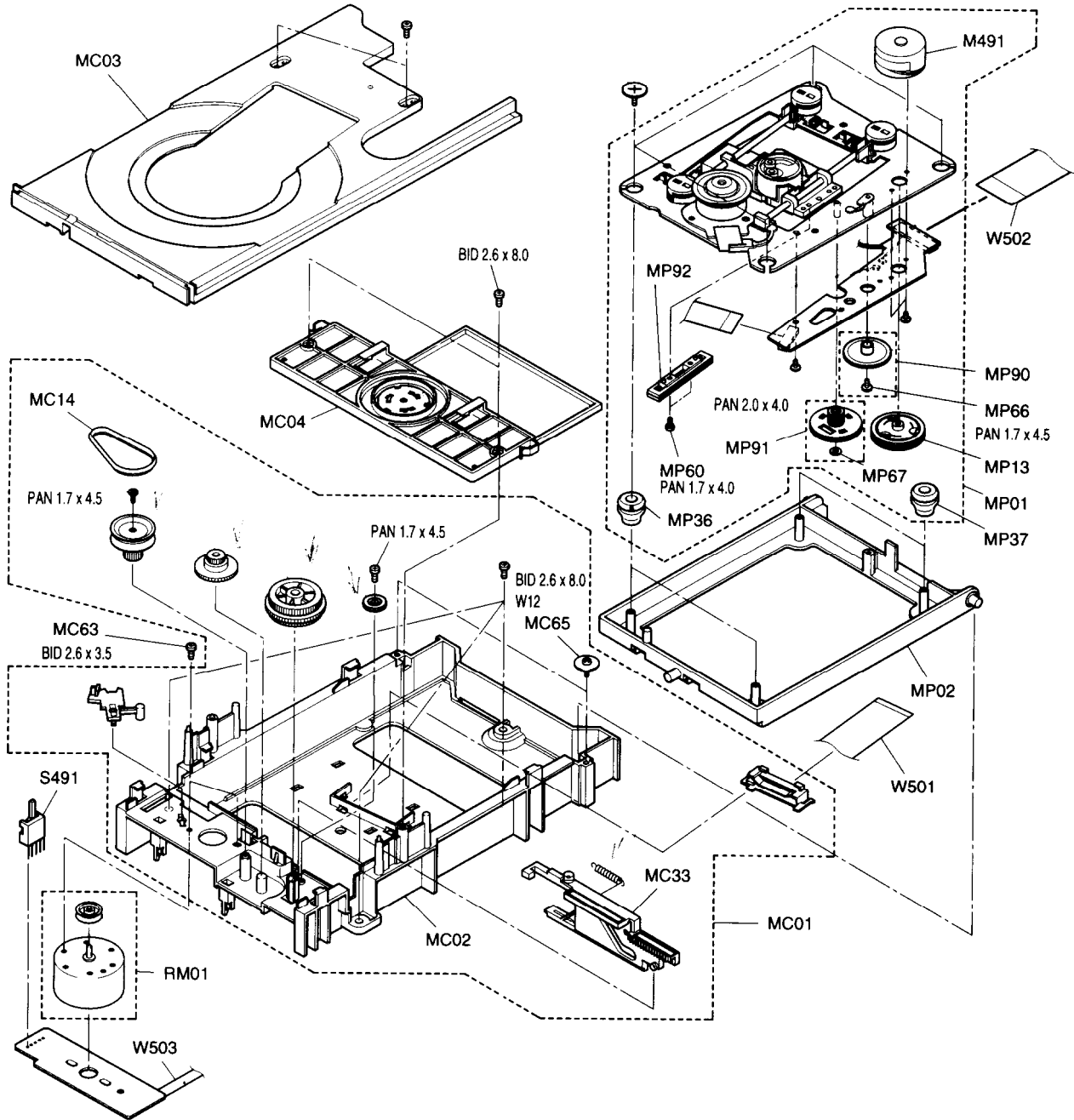

## MECHANISM PARTS

REF.No	PART No	DESCRIPTION	REMARK	REF.No	PART No	DESCRIPTION	REMARK
M491	79070015	MOTOR,FEED	RF-300PA	MP61	79070083	SCREW	PAN 1.7 x 0.5W9
MC03	79070232	TRAY	TRAY-21	MP64	79070084	SCREW	PAN 1.7 x 4.0
MC04	79070139	CLAMPER,ASSY		MP66	79070085	SCREW	PAN 1.7 x 4.5
MC14	79070140	BELT,LOAD		MP67	79070086	WASHER	W-5-1.65
MC63	79070028	SCREW	BID 2.6 x 3.5	MP90	79070087	GEAR,A,KIT	
MC65	79070064	SCREW	BID 2.6 x 8W12	MP91	79070088	GEAR,B,ASSY,KIT	
MP01	79070339	MECHANISM ASSY PU	MECHA,ASSY,PU,A	MP92	79070089	GEAR,RACK,PU,ASSY	
MP02	79070023	SHASSIS.SUB		RM01	79070162	MOTOR,LOADING,ASSY	
MP13	79070011	GEAR,FEED,M,ASSY	With magnet	S491	79070163	SWITCH	SW-SSCF
MP36	79070012	DUMPER RUBBER FRONT		W501	79080020	CABLE,FLEXIBLE	FFC-21P-L292
MP37	79070082	DUMPER RUBBER REAR		W502	79080021	CABLE,FLEXIBLE	FFC-19P-L185
				W503	79080059	CABLE,FLEXIBLE	FFC-5P-L288
				ZG27	79070162	LABEL,PU,CAUTN	

# PART REPLACEMENT AND ADJUSTMENT PROCEDURES

## CAUTIONS BEFORE STARTING SERVICING

Electronic parts are susceptible to static electricity and may easily be damaged, so do not forget to take a proper grounding treatment as required.

Many screws are used inside the unit. To prevent missing, dropping, etc. of the screws, always use a magnetized screwdriver in servicing. Several kinds of screws are used and some of them need special cautions. That is, take care of the tapping screws securing molded parts and fine pitch screws used to secure metal parts. If they are used improperly, the screw holes will be easily damaged and the parts can not be fixed.

## 1. REPLACEMENT OF MECHANICAL PARTS

### 1-1. Cabinet Replacement

#### 1-1-1. Top Cover

1. Remove five screws (1) and remove the top cover (2).

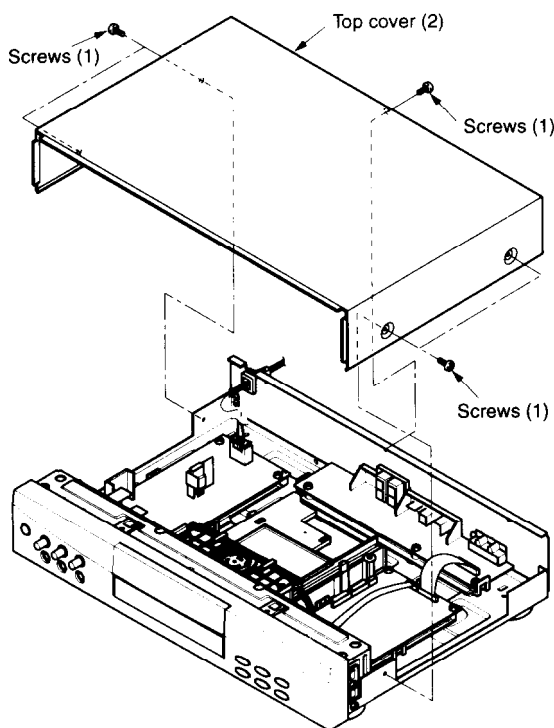

Fig. 1-1-1

#### 1-1-2. Tray

1. Remove two screws (2) of the tray (1).
2. Push the portion (A) in Fig. 1-1-2 using a screwdriver, etc. and release the lock of the tray (1).
3. Pull out the tray (1) after moving the tray (1) in forward direction.

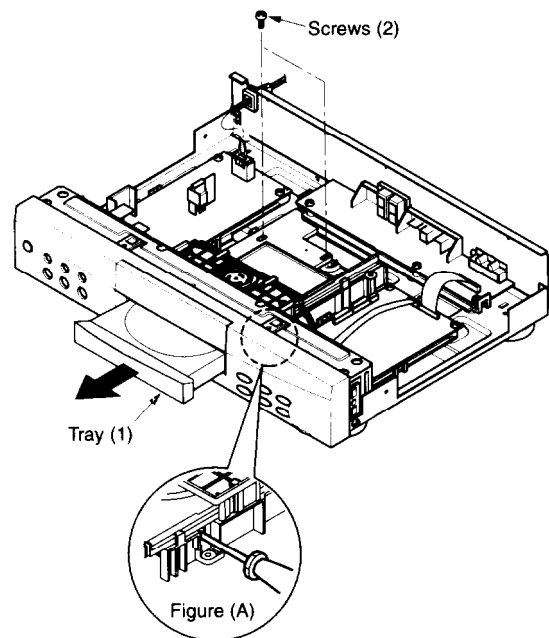

Fig. 1-1-2

#### 1-1-3. Tray Panel

1. Insert a flat-blade screwdriver into the portion (A) between the tray (1) and the tray panel (2), to unlock the two claws, and remove the tray panel (2).
2. To mount the tray panel (2), fit the tray panel (2) into the groove on both sides until it clicks.

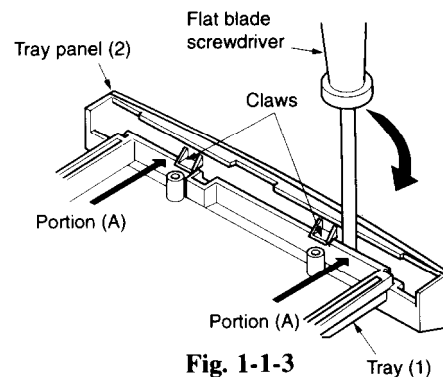

Fig. 1-1-3

## 1-2. PC Board Replacement

### 1-2-1. Main PC Board and Interface PC Board

#### Note:

- Before removing the main PC board, be sure to short-circuit the laser diode output land. After replacing the PC board, open the land after inserting the flexible connector (2).
1. Remove the top cover (Refer to item 1-1-1).
  2. Remove the flexible connectors (2) connected to the main PC board (1) and the connector (3). (Each connector is connected to the locations (A) to (G).)
  3. Remove four screws (4) , and remove the main PC board (1) and stay (5).
  4. Remove two claws of the stay (5) and remove the main PC board (1).
  5. When mounting, tighten four screws (4) matching each hole of the main PC board (1), stay (5) and bottom plate.

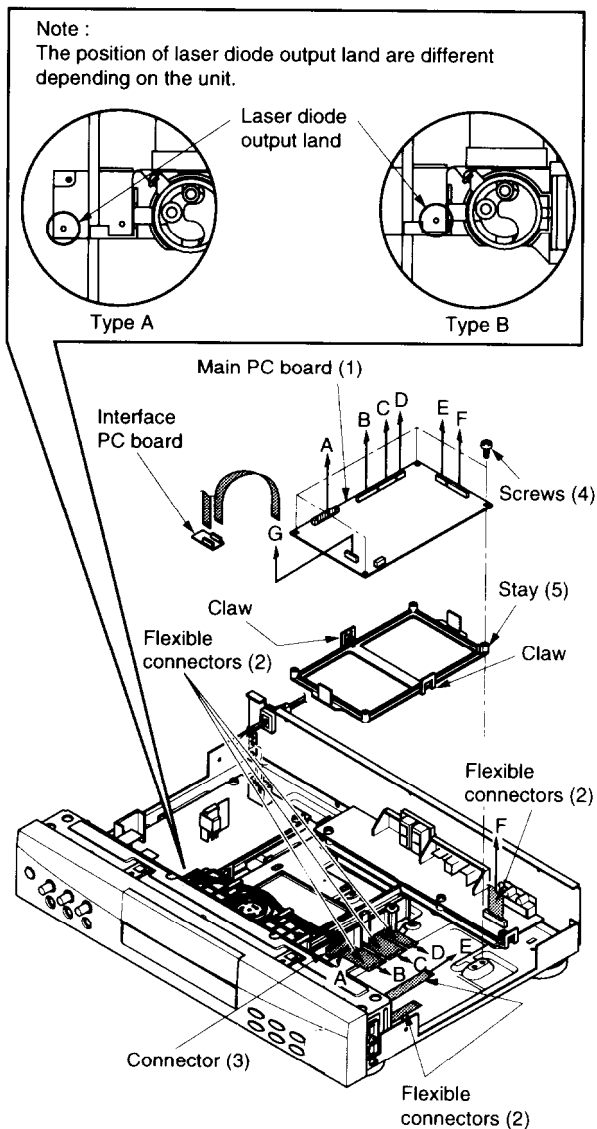

Fig. 1-2-1

## 1-3. Mechanism Parts Replacement

### 1-3-1. Mechanism Chassis Assembly

#### Note:

- Before removing the flexible connector and connector, be sure to short the laser diode output land. After replacing the mechanism chassis assembly, open the land after inserting the flexible connector and connector.
1. Remove the tray. (Refer to item 1-1-2.)
  2. Remove three screws (1), and remove the mechanism chassis assembly (2).

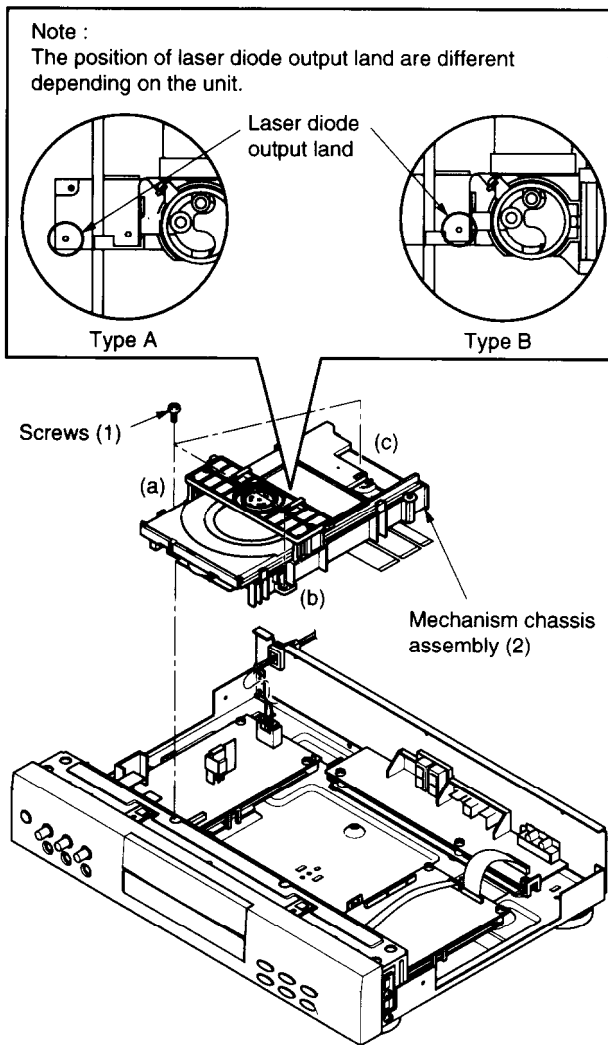

Fig. 1-3-1

#### Note:

- When mounting mechanism chassis assembly (2), attach the screws (1), (a) to (c) in order.

### 1-3-2. Loading Motor and Detection Switch

#### <Removal>

1. Peel off the tape (2) fixing the flexible connector (1).
2. Desolder the loading motor terminal.
3. Loosen three molded claws (3), and remove the loading motor PC board (4) (Refer to Fig. 1-3-2).
4. Desolder, and remove the detection switch (5).
5. Remove the loading belt (6) (Refer to item Fig. 1-3-3).
6. Remove two screws (7), and remove the loading motor (8).

#### <Mounting>

1. Align the positioning hole of a new loading motor (8) to the hole into which the chassis positioning boss is inserted, and fix the motor with two screws (7). (Refer to Fig. 1-3-3.)
2. Perform the reverse steps of removal described above for mounting.

#### Notes:

- When mounting the loading motor PC board (4), insert the end of the detection switch (5) into the notch of the kick lever. (Refer to Fig. 1-3-2.)
  - When mounting the loading belt (6), take care not to twist the belt or touch grease.
  - Be sure to open the molded claws (3) manually when mounting the loading motor PC board (4).
- When the loading motor PC board (4) is pushed in directly without opening the molded claws (3), the molded claws (3) may be destroyed.

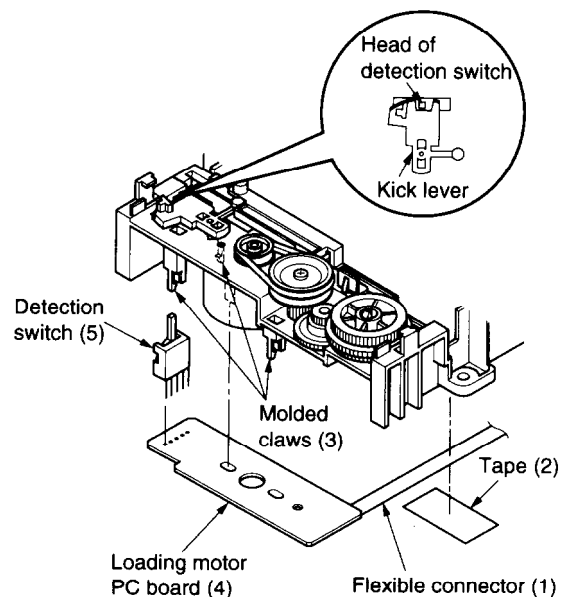

Fig. 1-3-2



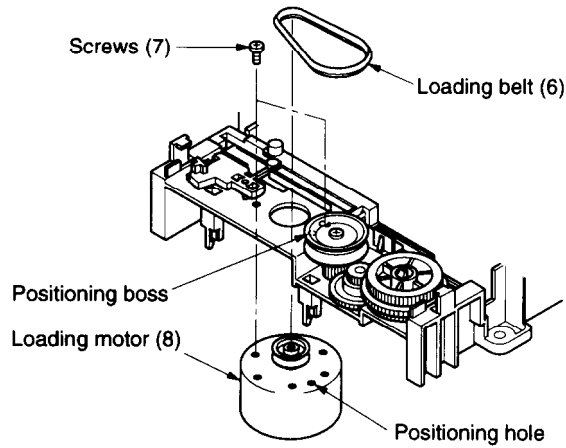

Fig. 1-3-3

### 1-3-3. Pickup Mechanism Assembly

#### <Removal>

1. Remove two screws (1), and remove the clamber stay (2).
2. Remove the 21-pin flexible connector (3). (This is not locked, and can be removed simply by pulling.)
3. Remove two screws (4), and remove the sub chassis (5) (with the pickup mechanism assembly).
4. Remove four screws (6), and remove the pickup mechanism assembly (7).
5. Remove the 19-pin flexible connector (8).

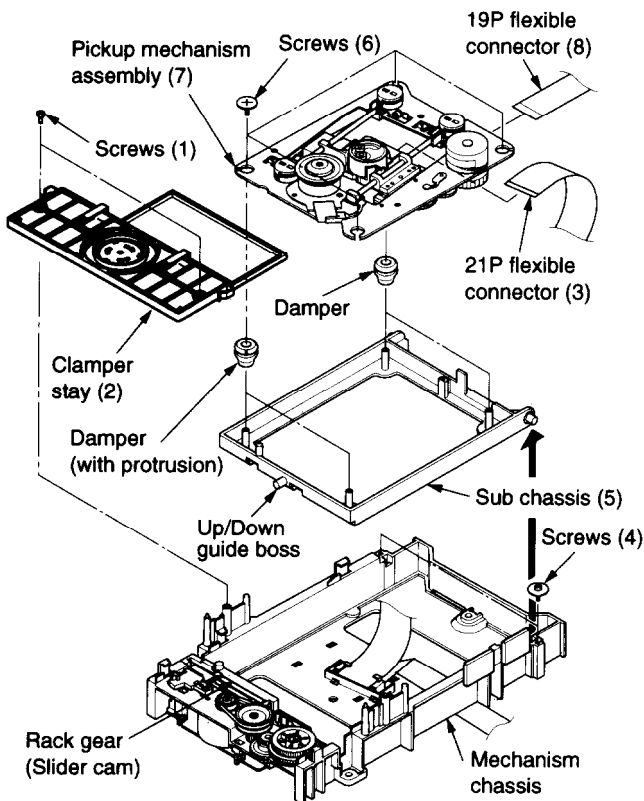

Fig. 1-3-4

#### <Wiring of the flexible connector>

It is necessary to bend the flexible wire of the mechanism chassis when wiring. When bending the flexible wire, perform the procedure referring Fig. 1-3-5.

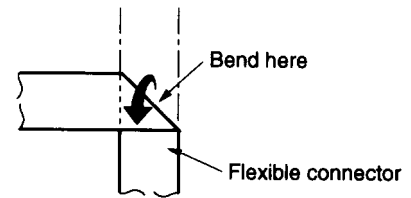
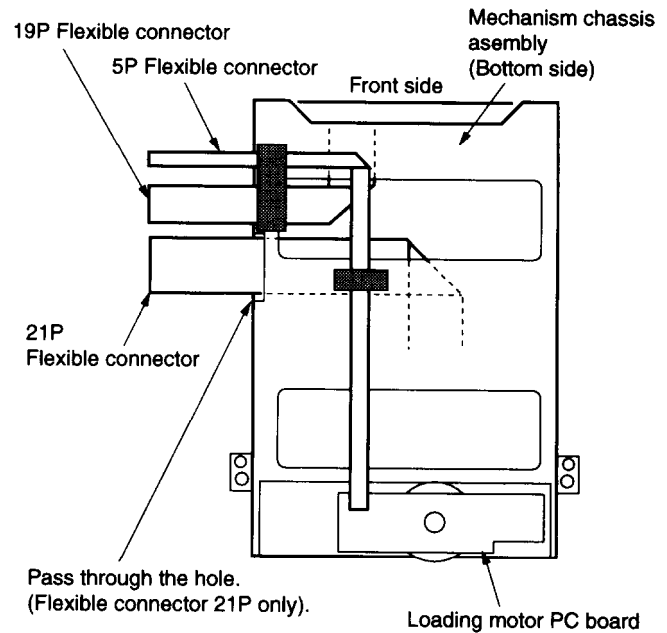

Fig. 1-3-5

#### <Removal of connector with the flexible connector lock>

Pull the connector slider in the direction of the arrow with your fingers. The connector is unlocked, and the 19-pin flexible connector (8) can be removed.

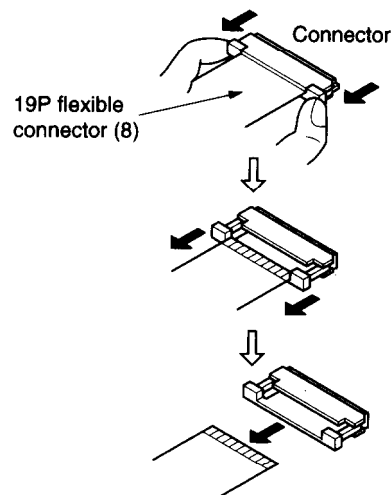

Fig. 1-3-6

**<Mounting>**

1. Replace the pickup mechanism assembly (7).
2. Face the correct side of the 19-pin flexible connector (8) up and connect it to a new pickup mechanism assembly (7). (Face the metallic side of the pickup mechanism assembly (7) up viewing it from the rear side, insert it into the connector, and lock it by sliding the connector in the direction of the arrow.)

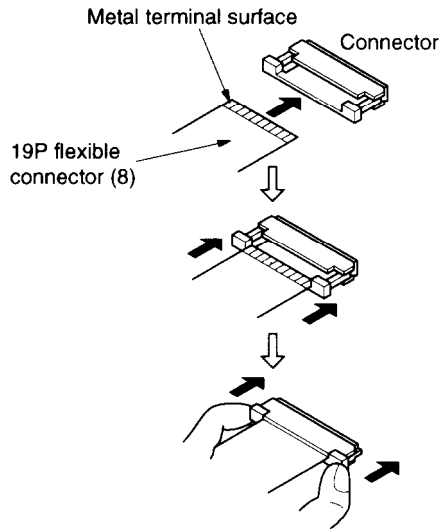

Fig. 1-3-7

3. Perform the reverse steps of removal described on previous page for mounting.

**Note:**

- When fixing the pickup mechanism assembly (7) with four screws (6), take care not to catch the damper. Push the mechanism assembly (7) down and loosen the damper, and tighten the screws (6).

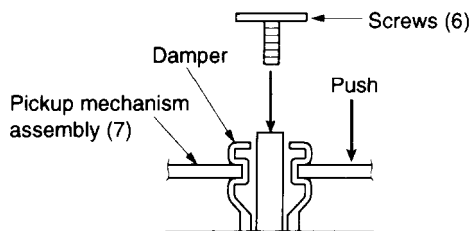

Fig. 1-3-8

- Use the damper with a protrusion (2 locations) in the disc motor, and use a damper without a protrusion on the rear side.

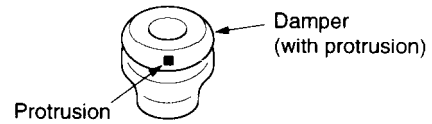

Fig. 1-3-9

- When mounting the sub chassis (5) (with the pickup mechanism assembly), insert the Up/Down guide boss into the cam slider Up/Down cam.

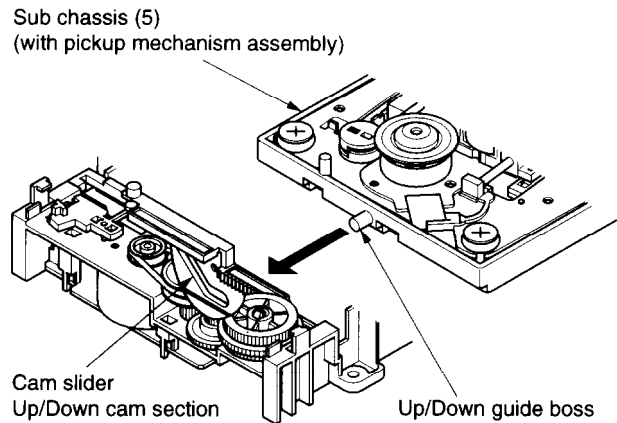

Fig. 1-3-10

**1-3-4. Gear B Assembly, Gear A, Feed Motor Gear Assembly and Rack Gear Assembly**

**<Removal>**

1. Remove the pickup mechanism assembly (Refer to item 1-3-3).
2. Remove the polyslider washer (1), and remove the gear B assembly (2). (Refer to Fig. 1-3-10.)
3. Remove one screw (3), and remove the gear A (4).

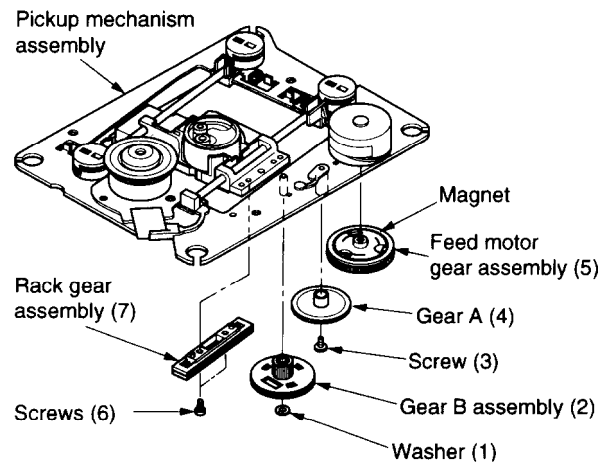
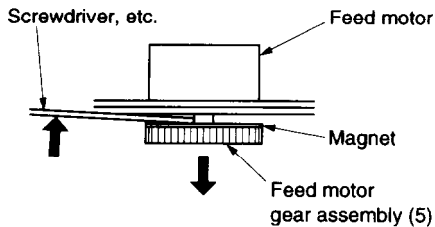

Fig. 1-3-11

- Remove the feed motor gear assembly (5) using screwdriver, etc. with care taken not to break the magnet. (Refer to Fig. 1-3-12.)

**Note:**

- Apply lightly the screwdriver, etc. end to the gear shaft and push upward, and pull out the feed motor gear assembly (5).

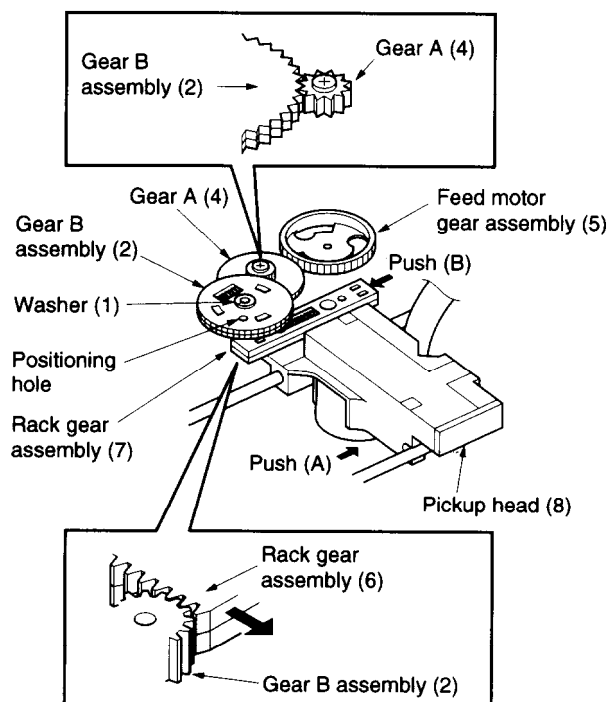

**Fig. 1-3-12**

- Remove two screws (6), and remove the rack gear assembly (7). (Refer to Fig. 1-3-13.)

**<Mounting>**

- Perform the reverse steps of removal described on previous page for mounting.
- Push the pickup head (8) to the disc motor side (direction of the arrow (A)), and push and slide the upper gear of the rack gear assembly (6) (direction of the arrow (B)).
- Align the positioning holes of the upper and lower gears of the gear B assembly (2), insert them into the gears of the gear A (4) and the rack gear assembly (7), and fix them with the washer (1).

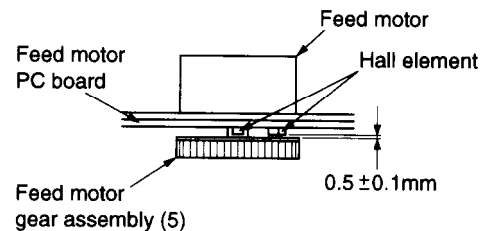

**Fig. 1-3-13**

**Notes:**

- Push the feed motor gear assembly (5) to fit it in position.
- Fit the feed motor gear assembly (5) at the height where the clearance is  $0.5 \pm 0.1$  mm between the feed motor gear assembly and the hall element on the feed motor PC board.
- When replacing the hall element, be sure to fit the hall element to the pattern surface of the feed motor PC board.

Then, solder the hall element on the feed motor PC board without leaving any clearance.



**Fig. 1-3-14**

### 1-3-5. Feed Motor

#### <Removal>

1. Remove the gear B assembly, the gear A and the feed motor gear assembly (Refer to item 1-2-4).
2. Remove two screws (1), and remove the feed motor (2). (Refer to Fig. 1-3-15.)
3. Desolder the feed motor lead (4) from the feed motor PC board (3).

#### <Mounting>

1. Solder the lead wire (4) of a new feed motor (2) to the feed motor PC board. (Pay attention to the lead wire color.)
2. Fix the feed motor (2) with two screws (1) with attention paid to the motor angle. (The motor side end of the lead wire (4) is to be aligned to the positioning concave on the pickup mechanism assembly.)
3. Fix the feed motor lead wire (4) with a cotton tape. Use a new cotton tape.

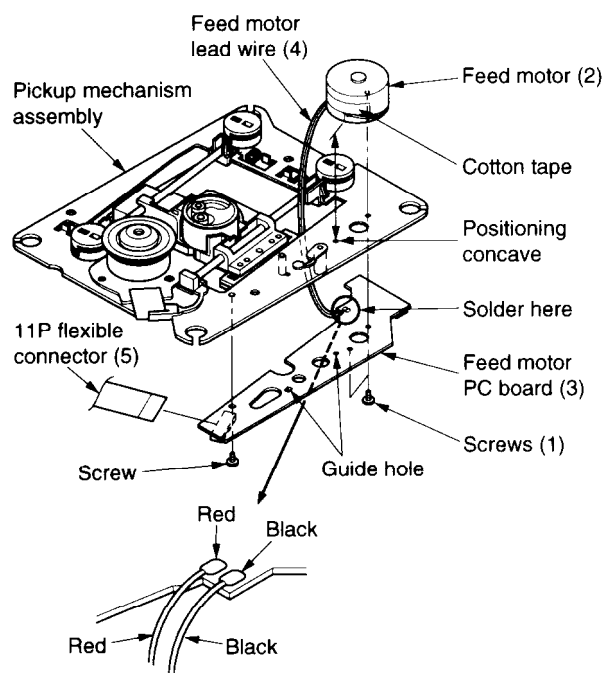
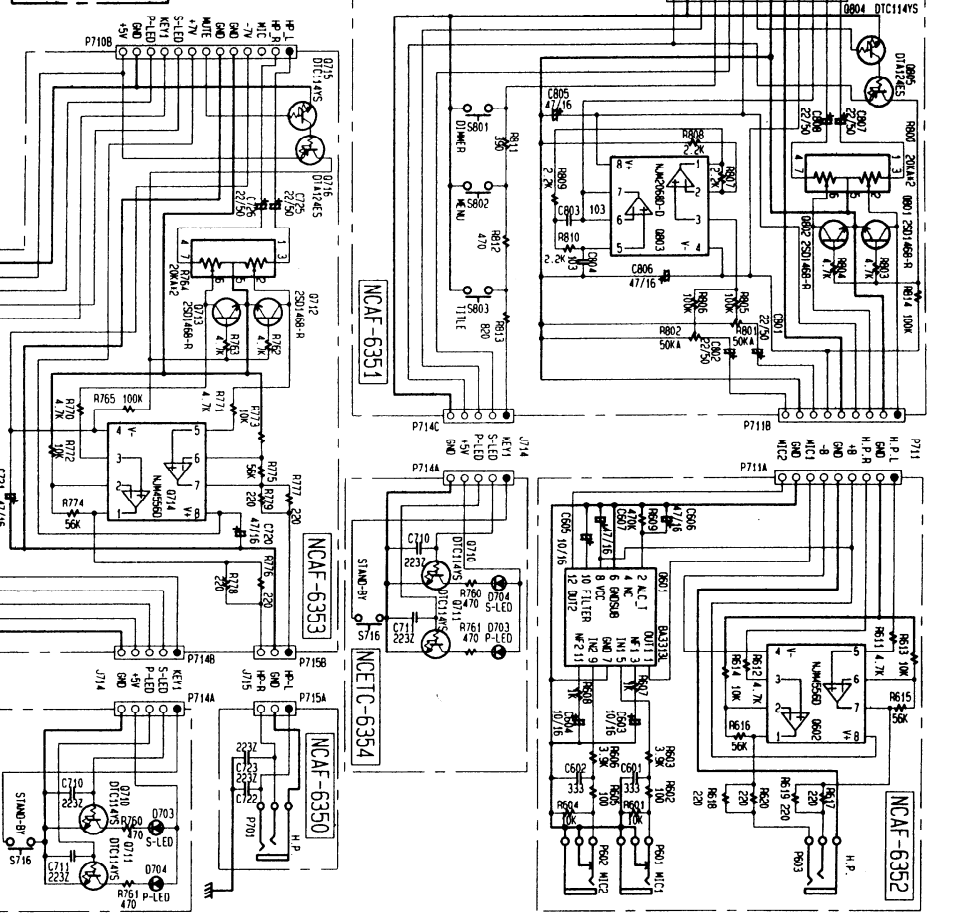
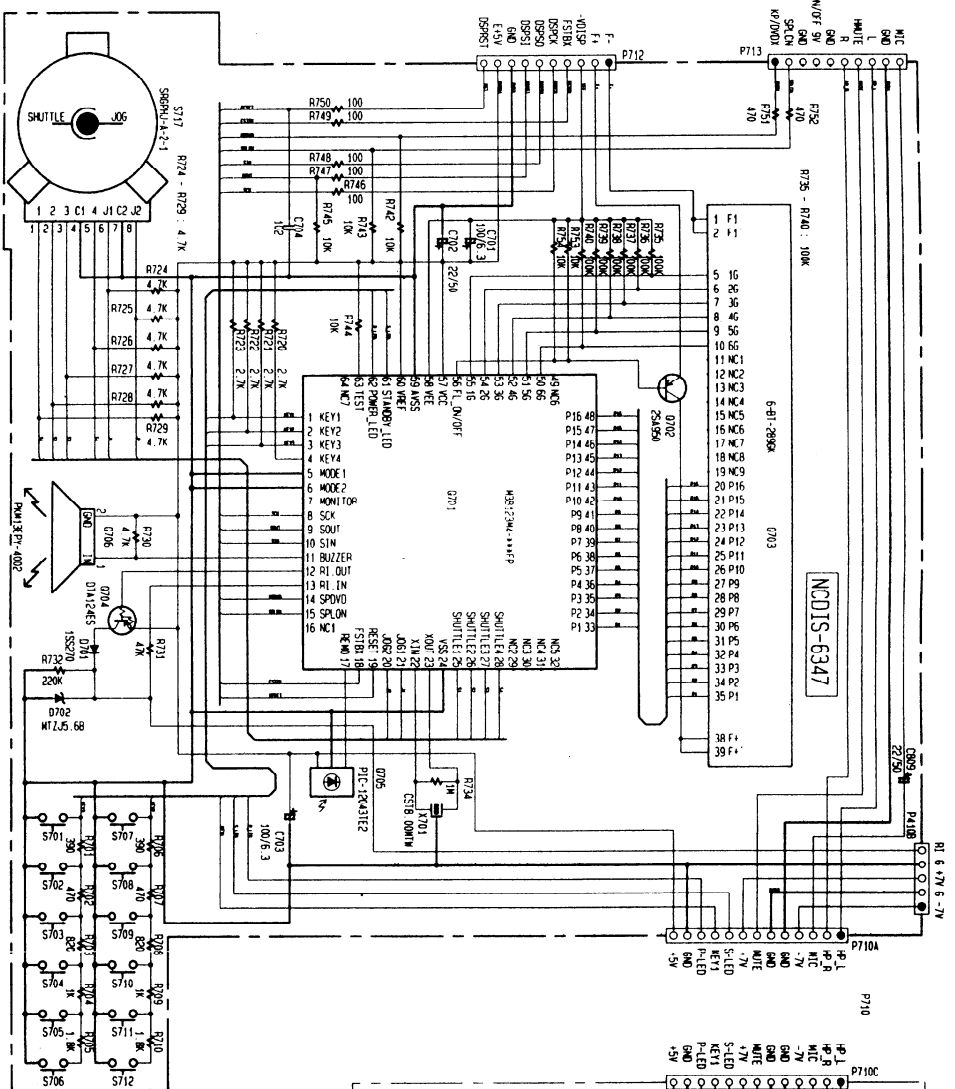

Fig. 1-3-15



SCHEMATIC DIAGRAM (DISPLAY)

A B C D E F G



**NOTE**  
 THE COMPONENTS IDENTIFIED BY MARK **▲** ARE CRITICAL FOR SAFETY.  
 REPLACE ONLY WITH PART NUMBER SPECIFIED.  
 VALUES INDICATED WITH NO TOLERANCE ( ) IS IN OHMS, (K) IN KILOHMS, (M) IN MEGOHMS.  
 ALL DIMENSIONS ARE GIVEN IN INCHES UNLESS OTHERWISE NOTED.  
 ALL DIMENSIONS ARE GIVEN IN MILLIMETERS UNLESS OTHERWISE NOTED.  
 ELECTRICAL CAPACITORS ( ) ARE IN P.F., UNLESS OTHERWISE NOTED.  
 EX. 0.001-5W-33V-331-300V-333-Q-033AF  
 ALL RESISTORS ARE IN OHMS UNLESS OTHERWISE NOTED.  
 THE TUBE LINES ON THIS BOARD ARE THE PRINTING SIDE OF THE PARTS.  
 THE TUBE LINES ON THE BOARD ARE THE PRINTING SIDE OF THE PARTS.  
 CIRCUIT IS SUBJECT TO CHANGE FOR IMPROVEMENT.

SCHEMATIC DIAGRAM (TERMINAL)

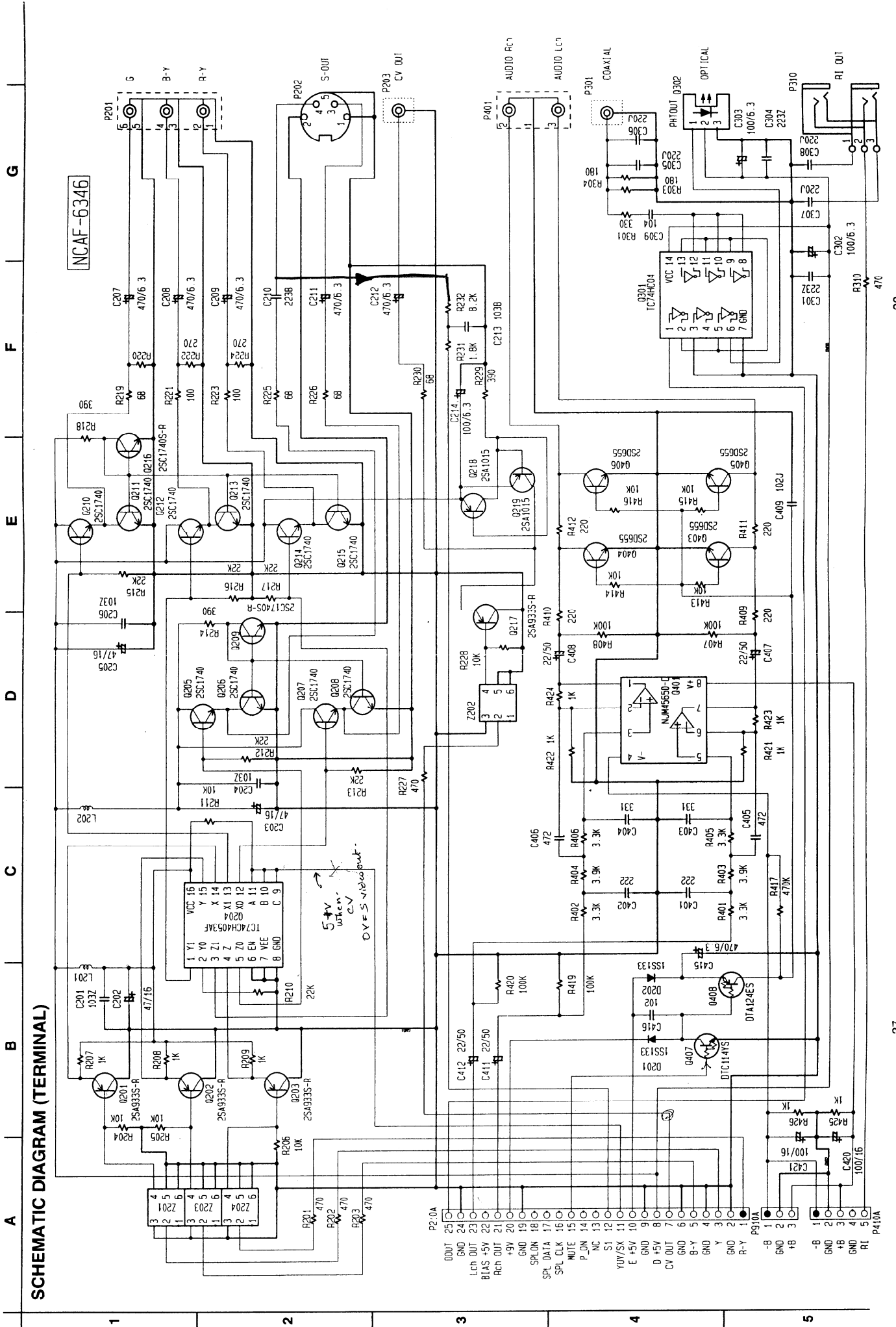

## SPECIFICATIONS

### Outputs

Video output	1.0V (p-p), 75 ohm, negative sync., pin jack x 1
S video output	(Y) 1.0 V (pp), 75 ohm, negative sync., Mini DIN 4-jack x 1 (C) 0.286 V (pp), 75 ohm
Color difference output	(Y) 1.0 V (pp), 75 ohm, negative sync., pin jacks x 1 (Cr)/(Cb) 0.7 V (pp), 75 ohm
Audio output (optical output)	Optical connector x 1
Audio output (digital output)	0.5 V (pp), 75 ohm, pin jack x 1
Audio output (analog output)	2.0 V (rms), 470 ohm, pin jacks (L,R) x 1
Headphone terminal	32 ohm (30 mW), Impedance : more than 8 ohm

### DVD Player

Power supply	<UD>120V AC, 60Hz <WT>120-240V, 50Hz/60Hz
Power consumption	<UD>20W <WT>19VA
Weight	4.5 kg
External dimensions	435 x 121 x 306 mm(W/H/D)
Signal system	<UD>Standard NTSC <WT>PAL/3.58 NTSC
Laser	Semiconductor laser, wavelength 650nm
Frequency range(digital audio)	DVD linear sound : 48 kHz sampling 4 kHz to 22 kHz 96 kHz sampling 4 kHz to 44 kHz Audio CD : 4 kHz to 20 kHz
Signal-to-noise ratio(digital audio)	More than 96 dB (EIAJ)
Audio dynamic range(digital audi	More than 96 dB (EIAJ)
Harmonic distortion(digital audio)	Less than 0.006 %
Wow and flutter	Below measurable level (less than +/-0.001% (W.PEAK) (EIAJ)
Operating conditions	Temperature : 5 °C to 35°C, Operation status : Horizontal

### Supplied Accessories

S video cable	x 1
Audio / video cable	x 1
Remote control (RC-375DV)	x 1
Batteries (AA)	x 2
RI cable	x 1

\*Designs and specifications are subject to change without notice.



PACKING VIEW

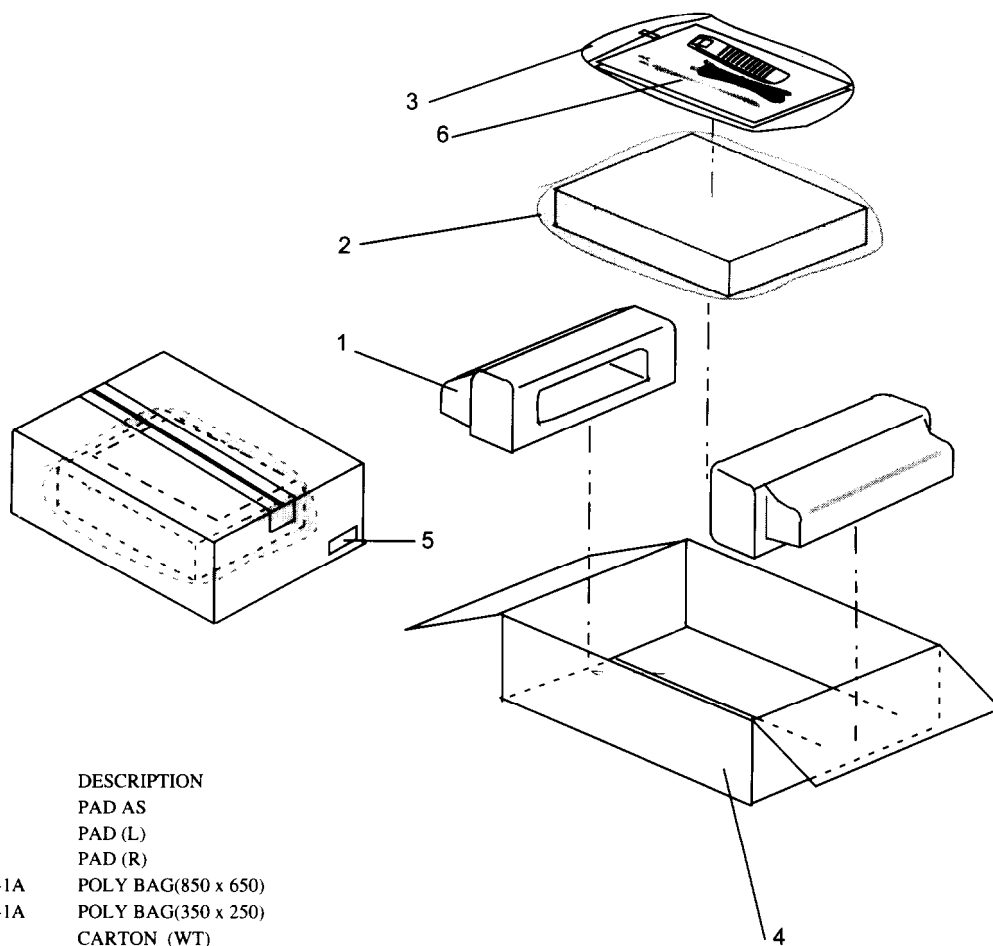

REF No	PART No	DESCRIPTION
1 A401	29091838	PAD AS
A402	29091839	PAD (L)
A403	29091839	PAD (R)
2 A404	29100034-1A	POLY BAG(850 x 650)
3 A407	29100097-1A	POLY BAG(350 x 250)
4 A501	29053290	CARTON (WT)
4 A501	29053288	CARTON (UD)
A502	29362036	LABEL (EX)
5 A503	29362307	LABEL (EAN) AS
5 A503	29362306	LABEL (UPC) AS
6 A504	29365019B	WRNTY CARD
6 A505	29358002K	SS LIST (UD)
6 A901	2010359	PIN CORD AS (RCA-3P YWR)
6 A902	2010360	CORD AS
6 A903	2010200	PLUG CORD(3.5-MINI PLUG)
6 A904	3010054	BATTERY(UM-3)
6 A911	29342574	INS MANUAL <UD>
6 A912	24140375	REMO UNIT (RC-375DV) <UD>
6 A920	29342575	INS MANUAL <WT>
6 A920	29342573	INS MANUAL <UD>
6 A921	29342592	INS MANUAL <WT>
6 A922	24140376	REMO UNIT (RC-376DV) <WT>
6 A923	25055040	PLUG (CV PLUG)

**ONKYO CORPORATION**

International Sales Div.: 31 Sankyo-bld. 3-8-5, Asakusabashi, Taito-ku, TOKYO 111, JAPAN  
 TEL : 03-5820-5865 FAX : 03-5820-5869

**ONKYO U.S.A. CORPORATION**  
 200 Williams Drive, Ramsey, N.J. 07446, U.S.A.  
 TEL : 201-825-7950 FAX : 201-825-8150

**ONKYO EUROPE ELECTRONICS GmbH**  
 Industriestrasse 18-20, 82110 Germering, GERMANY  
 TEL : 089 84 93 20 FAX : 089 84 93 226

**ONKYO FRANCE**  
 Immeuble Le Diamant, Domaine Technologique de Saclay, 4 Rue Rene Razel, 91892 SACLAY, FRANCE  
 TEL : (1) 69 33 1400 FAX : (1) 69 41 35 84