

ONKYO® SERVICE MANUAL

DVD PLAYER MODEL DV-S525

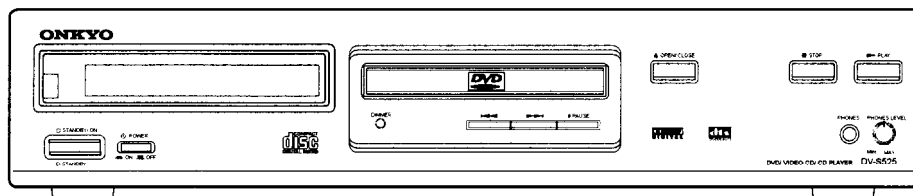

Black, Silver and Golden models

BUD	120V AC, 60Hz
BUP / BUPA	230V AC, 50Hz
BUWT	120-230V AC, 50/60Hz
GUPA	230V AC, 50Hz
GUWT	120-230V AC, 50/60Hz
SUP	230V AC, 50Hz

SAFETY-RELATED COMPONENT WARNING!!

COMPONENTS IDENTIFIED BY MARK \triangle ON THE SCHEMATIC DIAGRAM AND IN THE PARTS LIST ARE CRITICAL FOR RISK OF FIRE AND ELECTRIC SHOCK. REPLACE THESE COMPONENTS WITH ONKYO PARTS WHOSE PART NUMBERS APPEAR AS SHOWN IN THIS MANUAL.



MAKE LEAKAGE-CURRENT OR RESISTANCE MEASUREMENTS TO DETERMINE THAT EXPOSED PARTS ARE ACCEPTABLY INSULATED FROM THE SUPPLY CIRCUIT BEFORE RETURNING THE APPLIANCE TO THE CUSTOMER.

TABLE OF CONTENTS

Safety precautions/ Specifications-----	2
Front panel/ Rear panel view-----	3
Display view/ Remote controller-----	4
Microprocessor terminal description-----	5
Exploded view parts list-----	6
Exploded view-----	7-8
IC Block diagram-----	9
Firmware upgrade-----	10-12
Printed circuit board view-----	13-16
Schematic diagram-----	17-24
Printed circuit board parts list-----	25-26
Main PC board view-----	27-30
DVD mechanism view-----	31
DVD mechanism/ Main PC board parts list-----	32
Replacement mechanical parts-----	33-37
Trouble shooting-----	38-45
Wiring diagram-----	46
Packing view-----	47
Assemble the packing form-----	48-49

ONKYO®
AUDIO COMPONENTS

OPERATING INSTRUCTIONS SAFETY PRECAUTIONS

	WARNING RISK OF ELECTRIC SHOCK DO NOT OPEN	
AVIS RISQUE DE CHOC ELECTRIQUE NE PAS OUVRIR		
<p>WARNING : TO REDUCE THE RISK OF ELECTRIC SHOCK, DO NOT REMOVE COVER (OR BACK). NO USER-SERVICEABLE PART INSIDE. REFER SERVICING TO QUALIFIED SERVICE PERSONNEL.</p>		



The lightning flash with arrowhead symbol, within an equilateral triangle, is intended to alert the user to the presence of uninsulated "dangerous voltage" within the product's enclosure that may be of sufficient magnitude to constitute a risk of electric shock to persons.



The exclamation point within an equilateral triangle is intended to alert the user to the presence of important operating and maintenance (servicing) instruction in the literature accompanying the appliance.

WARNING : TO REDUCE THE RISK OF FIRE OR ELECTRIC SHOCK, DO NOT EXPOSE THIS APPLIANCE TO RAIN OR MOISTURE. DANGEROUS HIGH VOLTAGES ARE PRESENT INSIDE THE ENCLOSURE. DO NOT OPEN THE CABINET. REFER SERVICING TO QUALIFIED PERSONNEL ONLY.

CAUTION : TO PREVENT ELECTRIC SHOCK, MATCH WIDE BLADE OF PLUG TO WIDE SLOT, FULLY INSERT.

ATTENTION : POUR EVITER LES CHOC ELECTRIQUE, INTRODUIRE LA LAME LA PLUS LARGE DA LA FICHE DANS LA BORNE CORRESPONDANTE DA LA PRISE ET POUSSER JUSQU' AU FOND.

PRECAUTIONS

Replacing the fuses

For continued protection against risk fire, replace only with same type and same rating fuse.

CIRCUIT No.	PART No.	DESCRIPTION
F901 <UD>	252146	1.25A-TSC
F901 <UP/UWT,UPA>	252071	1.25A-SE-EAWK

 This symbol located near the fuse indicates that the fuse used is fast operating type. For continued protection against fire hazard, replace with same type fuse. For fuse rating refer to the marking adjacent to the symbol.

 Ce symbole indique que le fusible utilise est a rapide. Pour une protection permanente, n'utiliser que des fusibles de meme type. Ce dernier est indique la qu le present symbol est appose.

LASER BEAM CAUTION LABEL

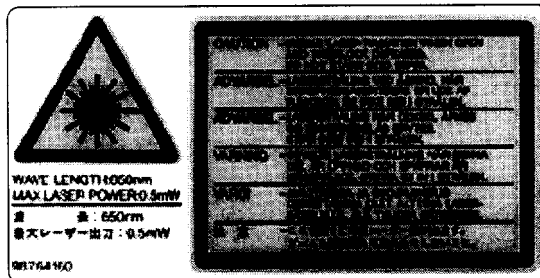

When the power supply is being turned on, you may not remove this laser cautions label, radiation of a laser may be received. Pickup Head consists of a laser diode that is very susceptible to external static electricity. Although it operates properly after replacement, if it was subject to electrostatic discharge during replacement, its life might be shortened. When replacing, use a conductive mat, soldering iron with ground wire, etc. to protect the laser diode from damage by static electricity. And also, the LSI and IC are same as above.

SPECIFICATIONS

DVD Player	
Power supply	UD : AC 120 V, 60Hz UP, UPA : AC230 V, 50Hz UWT: AC220V-230V, 50/60Hz
Power consumption	25 W
Weight	2.8 kg, 8.4lbs.
External dimensions	45 x 91 x 306 mm(W/H/D), 17-1/8" x 3-9/16" x 12-1/16" (W/H/D)
Signal system	Standard NTSC
Laser	Semiconductor laser, wavelength 650nm
Frequency range(digital audio)	DVD linear sound 48 kHz sampling 4 Hz to 22 kHz 96 kHz sampling 4 Hz to 44 kHz Audio CD : 4 Hz to 20 kHz
Signal to noise ratio(digital audio)	More than 90 dB (EIAJ)
Audio dynamic range(digital audio)	More than 87 dB (EIAJ)
Harmonic distortion(digital audio)	Less than 0.1 %
Wow and flutter	Below measurable level (less than ±0.001 % (W.PEAK)) (EIAJ)
Operating conditions	Temperature : 5 °C to 35 °C(41 to 95 Degree), Operation status: Horizontal

Outputs

Video output	1.0 V (p-p), 75 Ω, negative sync., pin jack x 1
S video output	(Y) 1.0 V (p-p), 75 Ω (C) 0.286 V (p-p), 75 Ω
Color different output	(Y) 1.0 V (p-p), 75 Ω, negative sync., pin jack x 1 (Cb)(Cr) 0.7 V (p-p), 75 Ω
Audio output (Optical audio)	Optical connector x 1
Audio output (Digital audio)	0.5 V (p-p), 75 Ω, pin jack x 1
Audio output (Analog audio)	2.0 V (rms), 470 Ω, pin jack(L, R) x 1
Headphone terminal	32 Ω (10mW), Impedance; more than 8 Ω

* Designs and specifications are subject to change without notice.

Front panel view

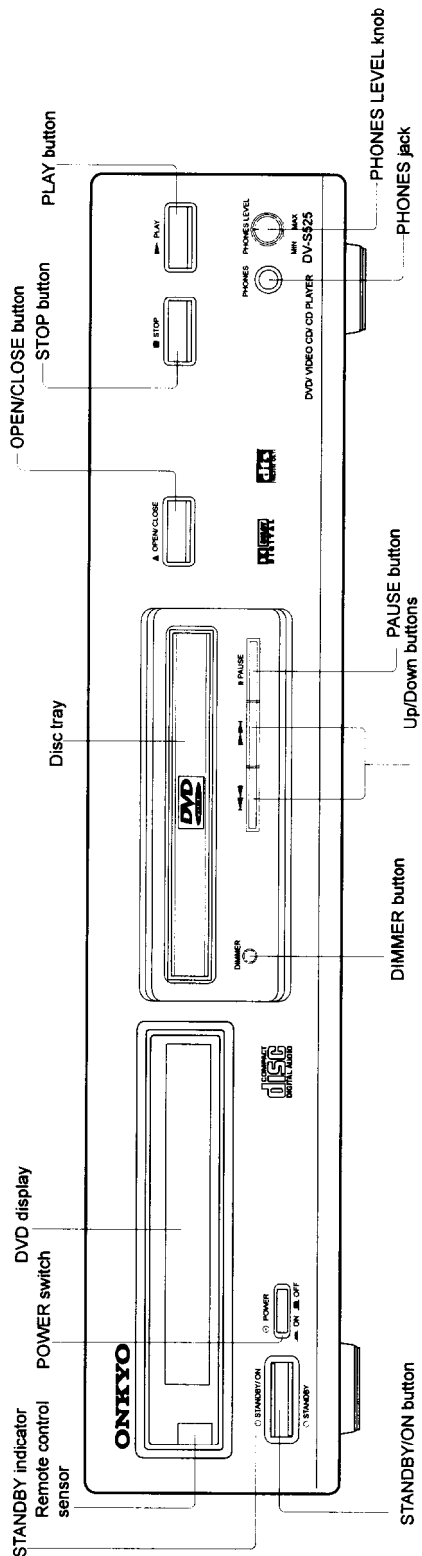

Rear panel view

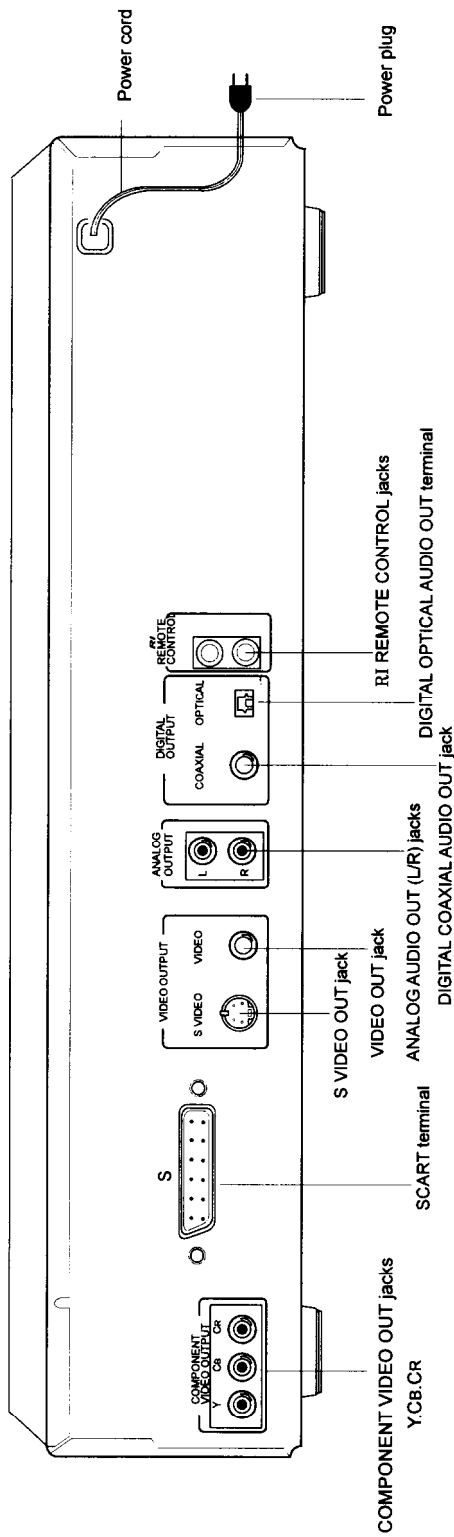

Display

• Pressing of the DIMMER button changes the brightness of the Display.

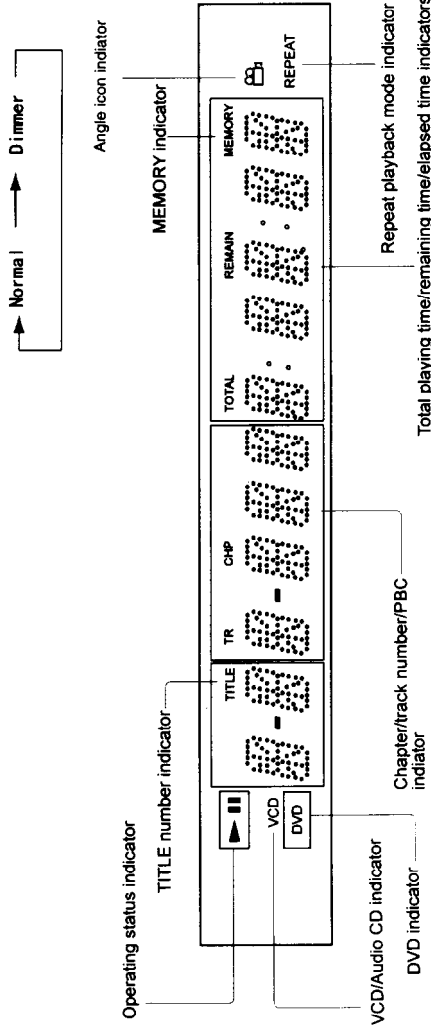

Remote controller

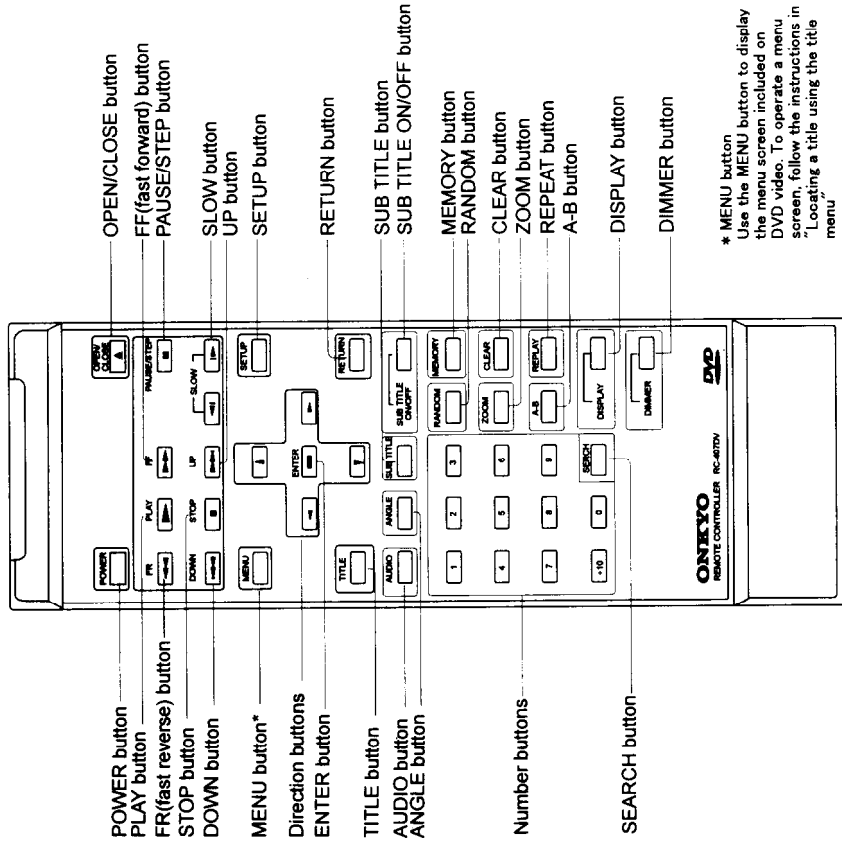

* MENU button
Use the MENU button to display the menu screen included on DVD video. To operate a menu screen, follow the instructions in "Locating a title using the title menu"

■ The indicators vary depending on the kinds of discs you play.

DVD video

• When closing the disc tray:
Example

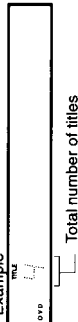

• During playback:



Some DVD video may not display the chapter numbers or elapsed time.

VIDEO CD

• When closing the disc tray:
Example

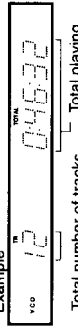

• During playback:



Audio CD

• When closing the disc tray:
Example

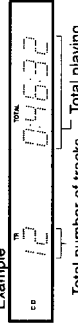

• During playback:



Some VIDEO CDs may not display the track numbers or elapsed time.

MICROPROCESSOR TERMINAL DESCRIPTION

PIN No.	TERMINAL	I/O	DESCRIPTION	PIN No.	TERMINAL	I/O	DESCRIPTION
1	7G	O	Grid output pins	30	AVREF	I	Reference voltage terminal for A/D converter
2	6G	O	Grid output pins	31	XT1	I	To connect the VSS terminal
3	5G	O	Grid output pins	32	XT2	O	Not used
4	4G	O	Grid output pins	33	VSS	I	Vss
5	3G	O	Grid output pins	34	X1	I	Crystal connection terminal for main system
6	2G	O	Grid output pins	35	X2	O	Crystal connection terminal for main system
7	1G	O	Grid output pins	36		O	Not used
8		-	Power supply pin (+VDD)	37	BUZZER	O	Buzzer signal output terminal
9	DVDPOFF	O	Not used	38	STANDBY_LED	O	Control the standby indicator
10	DVDPOWER	O	Not used	39	POWER_LED	O	Control the Power indicator (Not used)
11	STBYX	O	Strobe signal output terminal	40	TI1	O	Not used
12	DVCS	O	Not used	41	TO2	O	Not used
13	DSTBX	I	Main strobe output signal	42	TO1	O	Not used
14	DSPCKX	I	Main clock output signal	43	~SYSOUT	O	RI system code output terminal
15	DSPSI	O	To change the main input signal from the sub output signal	44	SYSIN	I	RI system code input terminal
16	DSPSO	I	To change the sub output signal from the main input signal	45	~POFF	O	Not used
17	DSPRST	I	Reset terminal	46	INTP1	O	Not used
18		O	Not used	47	~REMIN	I	Input terminal of the remote control sensor
19		O	Not used	48	IC	I	Internal connection pin
20	AVSS	I	Ground terminal for A/D converter	49	P72	O	Not used
21	ANI7	O	Not used	50	P71	O	Not used
22	ANI6	O	Not used	51	P70	O	Not used
23	ANI5	O	Not used	52	VDD	I	Power supply pin (+VDD)
24	ANI4	O	Not used	53	FL_ON/OFF	O	Connect to the FL tube
25	ANI3	I	Analog input pin for A/D converter	54		O	Not used
26	ANI2	I	Analog input pin for A/D converter	55		O	Not used
27	K1	I	Operation switch connection terminal	56		O	Not used
28	K0	I	Operation switch connection terminal	57		O	Not used
29	AVDD	I	Analog power supply terminal for A/D converter	58-70	P1	O	Segment output pins
				71	VKK-24V	I	Power supply pin for FL controller
				72-74	P14	O	Segment output pins
				75-80	13G	O	Grid output pins

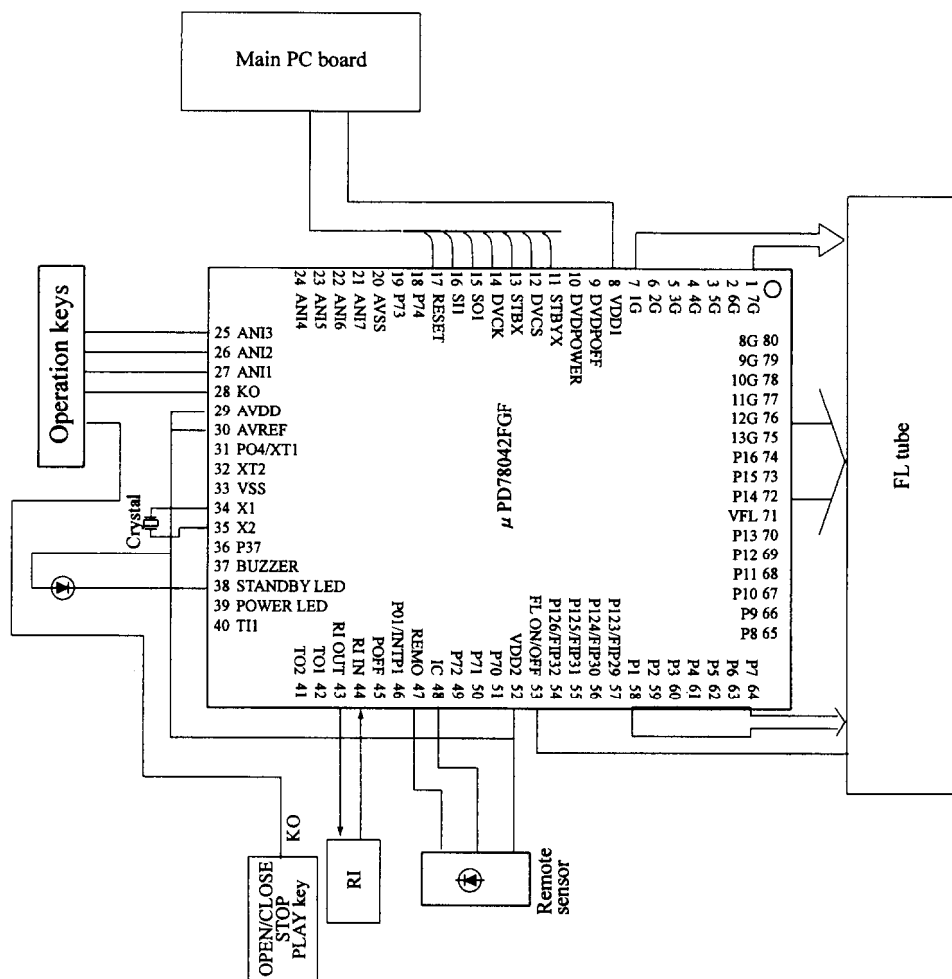

EXPLODED PARTS LIST

REF. No.	PART No.	DESCRIPTION	REF. No.	PART No.	DESCRIPTION
A001	27111130B	Front bracket 	A701	24801002	SD-2109K2-ZX, DVD mechanism
A003	27111131B	Front bracket <G>	E703	29362526	Firmware label
A005	27150441	(F), Shield plate	E801	2045131512	NCFC5-131512, Flexible flat cable
A006	28159040A	Decorative frame 	E802	2045131012	NCFC5-131012, Flexible flat cable
A007	28159041A	Decorative frame <G>	E803	2044190102	NCFC5-190102, Flexible flat cable
A008	27100378A	Chassis	E804	260208	Binder (Wire tie)
A009	29362541	(Bottom) Label	E805	2042183012	NCFC2-183012, Flexible flat cable
A010	27190266	KGLS-12RF, Holder	E806	2042081012	NCFC2-081012, Flexible flat cable
A011	27150440A	(FFC), Shield plate	E807	2047061212	NCFC7-061212, Flexible flat cable
A012	291110083	Tape, CROSS-16U	F901	252071	1.25A-SE-EAWK Fuse <UP,UWT,UPA>
A014	27225143	Shield case		252146	1.25A-TSC <UD>
A002	838130088	3TTB+8B, Self tapping screw	P901	253193HIT	AS-CEE, AC cord <UP,UWT,UPA>
A019	831430088	3TTW+8B(BC), Self tapping screw		253279HDK	AS-UC-2#18, AC cord <UD>
A020	27300750	S-RELIEF #2271, Bushing	U01	1H413599-1A	Power supply circuit PC board ass'y, NAPS-6699-1A <B,UD/B,UWT/G,UWT>
A201	28191860	Clear plate 	U01	1H413599-1B	Power supply circuit PC board ass'y, NAPS-6699-1B <B,UP/B,UPA/S,UP/G,UPA>
A203	28148418	Clear plate <G>	U01	1H413599-1C	Power supply circuit PC board ass'y, NAPS-6699-1C <G,UWT>
A204	28148419	Door 	U02	1H413500-1A	Output terminal PC board ass'y, NAAF-6700-1A <B,UD/B,UWT/G,UWT>
A206	27262644	Door <G>	U02	1H413500-1B	Output terminal PC board ass'y, NAAF-6700-1B <B,UP/B,UPA/S,UP/G,UPA>
A209	28198864	Plate 	U02	1H413500-1C	Output terminal PC board ass'y, NAAF-6700-1C <G,UWT>
A210	28325687	Plate <G>	U03	1H413501-1A	Display circuit PC board ass'y, NADIS-6701-1A <B,UD/B,UWT/G,UWT>
A212	28325688	Facet	U03	1H413501-1B	Display circuit PC board ass'y, NADIS-6701-1B <B,UP/B,UPA/S,UP/G,UPA>
A214	27273121B	Power knob 	U03	1H413501-1C	Display circuit PC board ass'y, NADIS-6701-1C <G,UWT>
A215	28325452	Power knob <G>	U04	1H413502-1A	Open/close switch PC board ass'y, NASW-6702-1A <B,UD/B,UWT/G,UWT>
A217	28325495	Joint	U04	1H413502-1B	Open/close switch PC board ass'y, NASW-6702-1B <B,UP/B,UPA/S,UP/G,UPA>
A301	28184764	(MIC), Knob 	U04	1H413502-1C	Open/close switch PC board ass'y, NASW-6702-1C <G,UWT>
A305	28184765	(MIC), Knob <G>	U05	1H413503-1A	Headphone terminal PC board, NAETC-6703-1A <B,UD/B,UWT/G,UWT>
A306	28184766	Top cover 	U05	1H413503-1B	Headphone terminal PC board, NAETC-6703-1B <B,UP/B,UPA/S,UP/G,UPA>
A307	838430088	Top cover <G>	U05	1H413503-1C	Headphone terminal PC board, NAETC-6703-1C <G,UWT>
A308	838930088	3TTB+8B(BC), Self tapping screw	U010	24150006	SD-20B1, Main PC board ass'y <B,UD>
A309	27175311A	3TTW+8B(UN), Self tapping screw <G>	U010	24150010	SD-20C2, Main PC board ass'y <B,UP/S,UP/B,UWT/G,UWT/B,UPA/G,UPA>
A310	27122642	Leg ass'y			
A311	27122643	Rear panel <UD>			
A312	27122644	Rear panel <UP>			
A313	27122645	Rear panel <UWT>			
A314	27122667	Rear panel <UPA>			
A315	27212126	Front panel, <B,UD>			
A316	27212140	Front panel, <B,UP, B,UPA>			
A317	27212142	Front panel, <B,UWT>			
A318	27212143	Front panel <G,UWT>			
A319	27212154	Front panel <G,UPA>			
A320	27212141	Front panel, <S,UP>			
A321	28135244	Badge 			
A322	28135245	Badge, <G,UWT/G,UPA/S,UP>			

NOTE:
 <UD> : 120V model only
 <UP> : 230V model only
 <UWT> : Worldwide model only
 <UPA> : Australian model only
 : Black model only
 <G> : Golden model only
 <S> : Silver model only

NOTE:
 THE COMPONENT IDENTIFIIDE BY MARK Δ
 ARE CRITICAL FOR RISK OF FIRE AND
 ELECTRIC SHOCK. REPLACE ONLY WITH
 PART NUMBER SPECIFIDE.

EXPLCIED VIEW

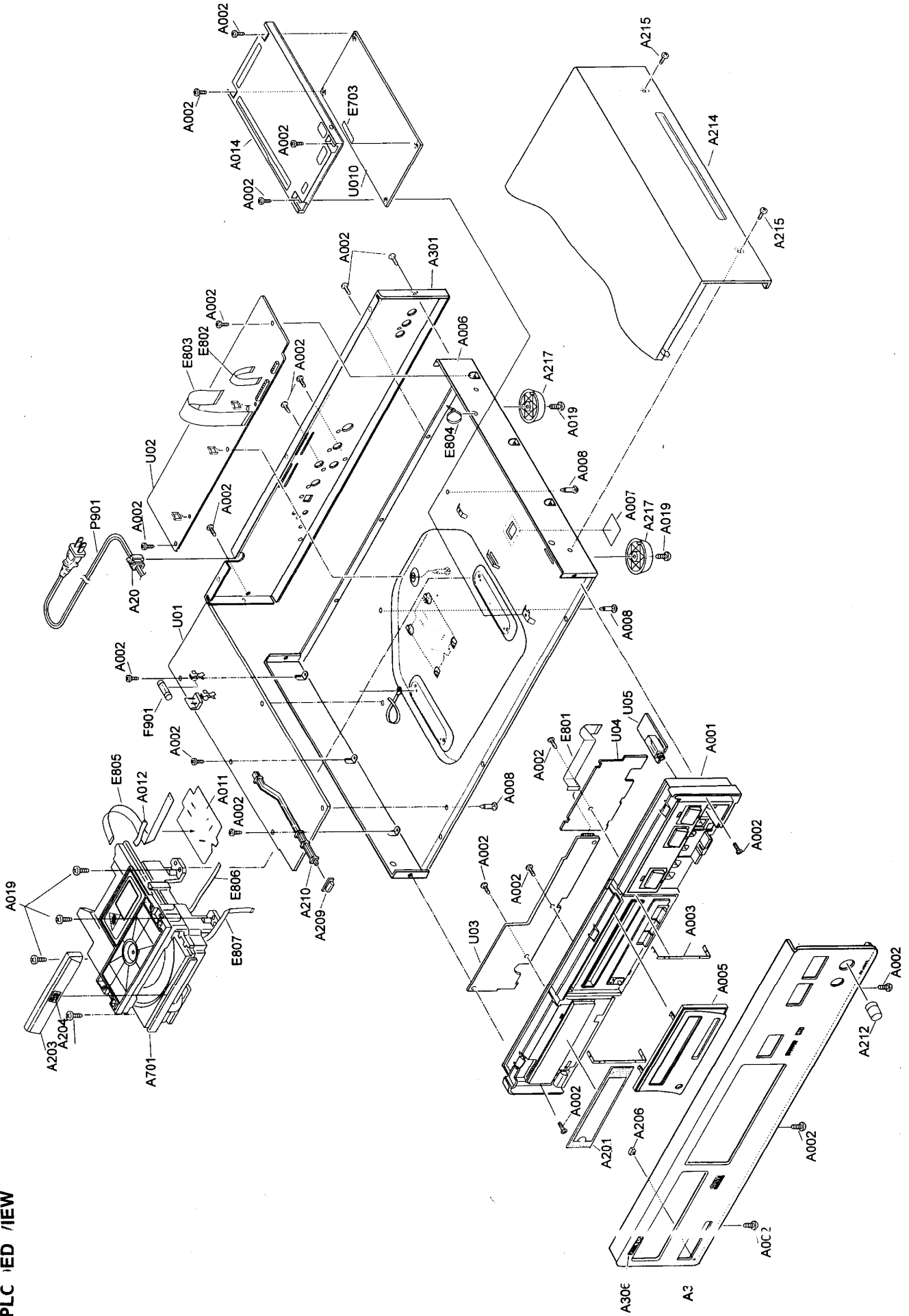

IC BLOCK DIAGRAM

STR-F6653 (SWITCHING REGULATOR)

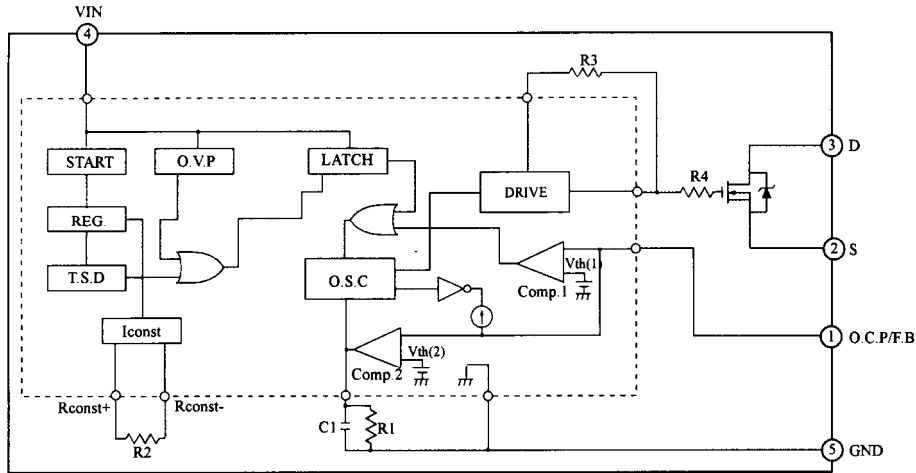

O.V.P: Built in overvoltage protection circuit
 T.S.D : Built in thermal shutdown circuit

Function of terminal

Terminal No.	Terminal Symbols	Description	Function
1	O.C.P/F.B	Overcurrent/Feedback terminal	Input of over current detection signal and constant voltage control signal
2	S	Source terminal	MOS FET source
3	D	Drain terminal	MOS FET drain
4	VIN	Power supply terminal	Input of power supply for control circuit
5	GND	Ground terminal	Ground

TC7HC4053FP

(Triple 2-channel analog multiplexe/demultiplexer)

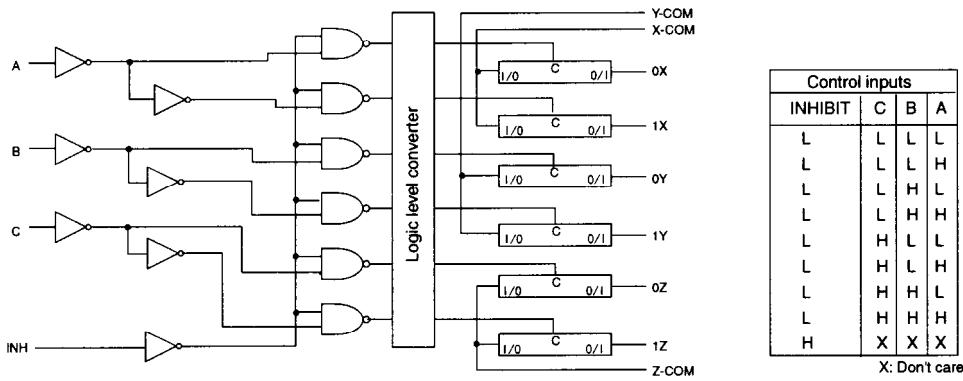

SI-3000C

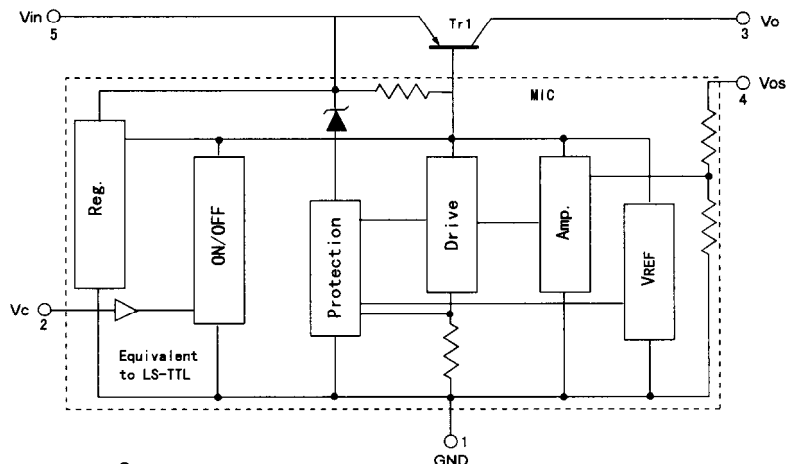

When Upgraded Firmware

1. When the firmware is upgraded, rewriting the new firmware into IC615 may be requested for servicing.
2. Connect a computer to the main PC board of the DVD video player with using UPGRADED FIRMWARE KIT (P/No. 0P37)

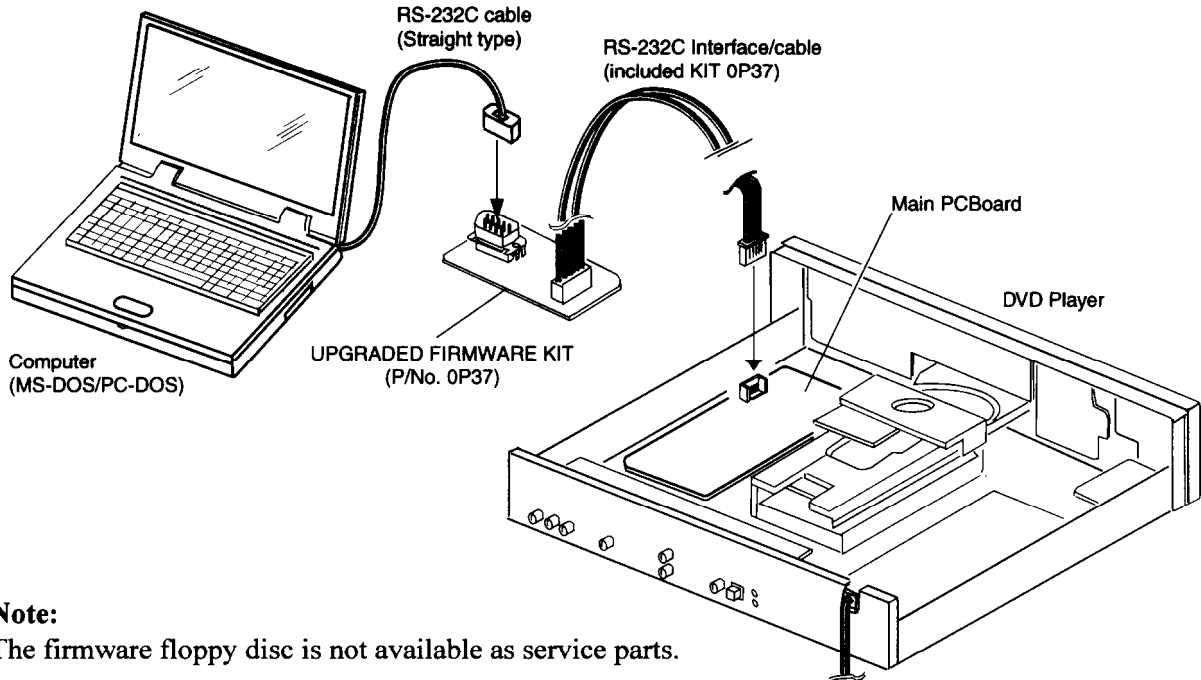

Note:
The firmware floppy disc is not available as service parts.

3. Writing of firmware (all destinations) in main board

- 3-1 The power supply is turned on and press the STANDBY/ON button to turn on the DVD player.
- 3-2. Connect a computer to the main PC board of the DVD video player with using UPGRADED FIRMWARE KIT (P/No. 0P37)
- 3-3. The program for the data writing is executed with the personal computer.
- 3-4. Type the following command in DOS prompt mode.
Flash5 "firmware filename"
- 3-5. Select [1.WRITE] when the MENU appeared on your screen.

```

C:\> flash5 w3100 z24
-----
Flash Writer Ver5.0 (c)TOSHIBA 1997

Please Select Mode: 1.WRITE 2.VERIFY 3.WRITE&VERIFY E End
    
```

After about 10 min.

<screen>

```

00000000000000000000000000000000
ALL CHECK SUM (Send: 0xF8AC340E vs Receive: 0xF8AC340E)----0000
Continue? [Y/N]
    
```

It is confirmed that the end of ALL CHECK SUM is "0000". (Write it again, except for this)

4. Confirmation of content of writing (all destinations)

4-1. The "STOP" key and the "SKIP-DOWN" key are pushed at the same time in the state of No Disc.

4-2. It is confirmed that the display of monitor is as follows.

UD area

ROM Version V*.*** -R1			
OSD	ENG/FRE/SPA		
VCD	ON	BUZZER	OFF
A.3D	OFF	RANDOM	ON
KARA	OFF	DTS	ON
VOCAL	SETUP	DIMMER	3TYP
C.S.	ON	V-FMT	NTSC
JOG	OFF	MPEG-A	ON
V.3D	ON		

UP area

ROM Version V*.*** -R2			
OSD	ENG/FRE/GER/SPA/ITA		
VCD	OFF	BUZZER	OFF
A.3D	OFF	RANDOM	ON
KARA	OFF	DTS	ON
VOCAL	SETUP	DIMMER	3TYP
C.S.	ON	V-FMT	P/N
JOG	OFF	MPEG-A	ON
V.3D	ON		

UWT area

ROM Version V*.*** -R3			
OSD	ENG-CHI-MAL		
VCD	ON	BUZZER	OFF
A.3D	OFF	RANDOM	ON
KARA	OFF	DTS	ON
VOCAL	SETUP	DIMMER	3TYP
C.S.	ON	V-FMT	P-N
JOG	OFF	MPEG-A	ON
V.3D	ON		

UPA area

ROM Version V*.*** -R4			
OSD	ENG/FRE/GER/SPA/ITA		
VCD	OFF	BUZZER	OFF
A.3D	OFF	RANDOM	ON
KARA	OFF	DTS	ON
VOCAL	SETUP	DIMMER	3TYP
C.S.	ON	V-FMT	P/N
JOG	OFF	MPEG-A	ON
V.3D	ON		

5. Display confirmation of FL tube

All lighting of the FL tube only while "STOP" is being pushed when "STOP" key is pushed while pushing "SKIP-UP" key to the main body key.

6. Setting of the first setup screen mode

6-1. The "STOP" key and the "DIMMER" key on the main body key are pushed at the same time in the state of No Disc.

6-2. It is confirmed that the Setup screen goes out, and the character of "First Setup ON" has come out in lower right.

6-3. The power supply again by On after turning off the power supply, and it is confirmed that the first setup screen goes out by Standby/ON mode. (Never push the Setup key here)

6-4. The power supply is turned off, and the AC code is pulled out.

7. Others

7-1. The factory setting of DIMMER must be normal.

7-2. The hollow becomes the horizontal position at the position of JOG by factory setting.

Factory setting confirmation

"SETUP" as follows each setting of the screen is confirmed.

UD,UWX-G area

<p>LANGUAGE SETTING</p> <p>On-Screen Language ENG</p> <p>Disc Menu Language ENG</p> <p>Audio Language ENG</p> <p>Sub Title ---</p>	<p>PICTURE</p> <p>TV Shape 4:3LB</p> <p>Black Level Enh.</p>	<p>AUDIO</p> <p>Audio out sel. Anal 2ch</p>
------------------------------------------------------------------------------------------------------------------------------------	--------------------------------------------------------------	---------------------------------------------

UWT area

<p>LANGUAGE SETTING</p> <p>On-Screen Language ENG</p> <p>Disc Menu Language ENG</p> <p>Audio Language ENG</p> <p>Sub Title ---</p>	<p>PICTURE</p> <p>TV Shape 4:3LB</p> <p>Black Level Enh.</p>	<p>AUDIO</p> <p>Audio out sel. Anal 2ch</p>
------------------------------------------------------------------------------------------------------------------------------------	--------------------------------------------------------------	---------------------------------------------

UP area

<p>LANGUAGE SETTING</p> <p>On-Screen Language ENG</p> <p>Disc Menu Language ENG</p> <p>Audio Language ENG</p> <p>Sub Title ---</p>	<p>PICTURE</p> <p>TV Shape 4:3LB</p> <p>Black Level Nml.</p>	<p>AUDIO</p> <p>Audio out sel. Anal 2ch</p>
------------------------------------------------------------------------------------------------------------------------------------	--------------------------------------------------------------	---------------------------------------------

UPA area

<p>LANGUAGE SETTING</p> <p>On-Screen Language ENG</p> <p>Disc Menu Language ENG</p> <p>Audio Language ENG</p> <p>Sub Title ---</p>	<p>PICTURE</p> <p>TV Shape 4:3LB</p> <p>Black Level Nml.</p>	<p>AUDIO</p> <p>Audio out sel. Anal 2ch</p>
------------------------------------------------------------------------------------------------------------------------------------	--------------------------------------------------------------	---------------------------------------------

PRINTED CIRCUIT BOARD PARTS LIST

POWER SUPPLY PC BOARD (NAPS-6699-1A/1B/1C)

CIRCUIT No.	PART No.	DESCRIPTION
	ICs	
Q901	△ 22241229	STR-F6653
Q904	22241230	SI3090C
Q905	22241231	SI3050C
Q906	22241232	SI3033C
Q903	22241233	SE005N
Q911	22241289R0	NJM2370U05
	Transistors	
Q913	2211164 or 2211163	2SC2120-Y or 2SC2120-O
Q907,Q909	2211504 or 2211503	2SA950-Y or 2SA950-O
Q908,Q912	2211945	2SK246-GR
Q910	2215915R0	HN1A01F-GR
Q914	2215925R0	HN1C01F-GR
	Diodes	
D901-D904	△ 22380287F	EM2A
D906	△ 22380291	EG01C
D907-D909	22380294	AG01Z
D910	22380295F	RN2Z
D911,D912	22380296F	RK46
D913	22380297	EU01
D914,D922	△ 22380294	AG01Z
D918	22380300F	RU2YX
D920	224493300R0	UDZ33B, Zener
D921	224490330R0	UDZ3.3B, Zener
D923	224490750R0	UDZ7.5B, Zener
D925	△ 22380294	AG01Z <UP,UPA>
D926	224491300R0	UDZ13B, Zener <UP,UPA>
	Labels	
E910	29361580	Fuse
E910	29361580	Fuse label,T1.25AL250V <UWT>
E910	29362309	Fuse label,1.25A/125V <UD>
	Fuse holder	
F901	25050065	YSH403T
	Coils	
L901	△ 231280	Choke coil,NCH-3561
L902	△ 230906	FR core,BL02RN2-R62
L903-L906	231253K100	Choke coilNCH-1490
L907	231253K100	Choke coilNCH-1490 <UP,UPA>
	Capacitor	
C907	3000115	220 μ F,2kV, Plastic
	Photo coupler	
Q902	24120044	ON3131-R
	Resistors	
R901	△ 4000076	0.22 ohm, 5W, Metal plate
R902	△ 411516844	680 ohm±5%, 1/2W, Carbon
R903	△ 441726834NF	68k ohm±5%, 2W, Metal oxide
R904	△ 441721044NF	100k ohm±5%, 2W, Metal oxide
R905	443522704	27 ohm,1/2W±5%, Metal oxide
R906	443522724	2.7k ohm,1/2W±5%, Metal oxide
R907	443522234	22k ohm,1/2W±5%, Metal oxide
R908	443526814	680 ohm,1/2W±5%, Metal oxide
R909	443523324	3.3k ohm,1/2W±5%, Metal oxide
R910	4500163	0.47 ohm±5%, 1/4W, Metal
R911	△ 451735194F	0.51 ohm±5%, 2W, Metal
R912	443521024	1k ohm±5%,1/2W, Metal oxide
R913	443522204	22 ohm,1/2W±5%, Metal oxide
R924	443522214	220 ohm,1/2W±5%, Metal oxide
	Switch	
S901	△ 25035702	NPS-121-L665P
	Transformer	
T901	△ 2301432	NPT-1380

CIRCUIT No.	PART No.	DESCRIPTION
	Plug	
P902	25055675	NPLG-2P631
	Socket AS	
P903	2002341020	NSAS-10P0034
P904	2002A392840	NSAS-28P0772
	Others	
Q901A	27160412	Heat sink,RAD-111
Q904A,Q905A, Q906A	27160145-1	Heat sink,RAD-51
Q901B,Q904B, Q905B,Q906B	838430107 838430107	Tapping screw,3TTB+10S(BC)

OUTPUT TERMINAL PC BOARD (NAAF-6700-1A/1B/1C)

CIRCUIT No.	PART No.	DESCRIPTION
	ICs	
Q301	222740046R00	74HCU04(TC74HCU04F)
Q401, Q402	22241383R0	NJM4565M-D
Q501,Q503	22241228R0 or 22241228R9	TC74HC4053FP or TC74HC4053FP <UP, UPA>
	Transistors	
Q201-Q204, Q208,Q209	2215915R0	HN1A01F-GR
Q205-Q207	2215925R0	HN1C01F-GR <UD, UWT>
Q210	2214490R0	RN1404 <UD,UWT>
Q211	2215925R0	HN1C01F-GR <UD, UWT>
Q212-Q214	2215915R0	HN1A01F-GR <UD, UWT>
Q226	2211164 or 2211163	2SC2120-Y or 2SC2120-O <UD, UWT>
Q303	2214540R0	RN2403
Q403, Q404	2215940R0	FMG12
Q405	2214490R0	RN1404
Q406	2214540R0	RN2403
Q502, Q504	2214490R0	RN1404 <UP, UPA>
Q505-Q511	2215915R0	HN1A01F-GR <UP, UPA>
	Photo coupler	
Q302	24120076	JFJ1000
	Diodes	
D201-D203	223266R0	1SS226
D204-D206	223266R0	1SS226 <UD,UWT>
D207	22380294	AG01Z
D301	224490560R0	Zener,UDZ5.6B
D302,D401, D402,D404	223234R0	1SS352
D403	22380294	AG01Z
D405,D406	22380294	AG01Z <UP,UPA>
D501-D506	223266R0	1SS226 <UP,UPA>
	Choke coils	
L201-L203	230921R0	BLM21B222SPT
L204-L206	230921R0	BLM21B222SPT <UD, UWT>
L301-L304	230921R0	BLM21B222SPT
L501-L504	230921R0	BLM21B222SPT <UP, UPA>
	LC Blocks	
Z201-Z204	3030041	Y-5(8.00MHz)
	Jacks	
P202	25045547	NPJ-1PDYE368
P204	25045590	NPJ-3PDB401 <UD, UWT>
P301	25045548	NPJ-1PDOR369
P302	25045330	NPJ-2PDBL184
P404	25045371	NPJ-2PDWR214
	Sockets	
P201	25051937	NSCT-13P1724
P203	25051750	NSCT-4P1537
P401	25051949	NSCT-25P1736
P501	25052279	NSCT-21P2176, Scart socket
	Plugs	
P402	25055154	NPLG-10P138
P403	25055149	NPLG-5P133

DISPLAY CIRCUIT PC BOARD (NADIS-6701-1A/1B/1C)

CIRCUIT No.	PART No.	DESCRIPTION
	IC	
Q701	22241388R3	MPD78042GF-112-3B9
	Transistors	
Q703	2211504 or 2211503	2SA950-Y or 2SA950-O
	Remote sensor	
Q704	241330	PIC-26043TE2
	LED	
D701	225370	SLR-342VRTB7
	FL tube	
Q702	212201	13-ST-40GNK
	Switches	
S701-S705	25035699	NPS-111-S662
	Socket	
P701	25051895	NSCT-13P1682
	Plug	
P702	25055368	NPLG-4P351
	Others	
X701	3010242	Ceramic filterCST5.00MGW
E701	27191085	FL holder

NOTE:

<UD> : 120V model only
 <UP> : 230V model only
 <UWT> : Worldwide model only
 <UPA> : Australian model only
 : Black color model
 <G> : Gold color model

NOTE: THE COMPONENT IDENTIFIDE BY MARK  ARE CRITICAL FOR RISK OF FIRE AND ELECTRIC SHOCK. REPLACE ONLY WITH PART NUMBER SPECIFIDE.

OPEN/CLOSE SWITCH PC BOARD (NASW-6702-1A/1B/1C)

CIRCUIT No.	PART No.	DESCRIPTION
	IC	
Q605	222654	NJM4556D
	Transistors	
Q601	2214490R0	RN1404
Q602	2214540R0	RN2403
Q603	2215940R0	FMG12
	Resistor	
R601	5132436	Phone level, N14RGL20KA17Z
	Switches	
S706-S708	25035699	NPS-111-S662
	Socket AS	
P604	2002A392055	NSAS-20P0749
P703	2002320810	NSAS-8P0025
	Wire holder	
P603	25051107	NSCT-3P894

HEADPHONE TERMINAL PC BOARD (NAETC-6703-1A/1B/1C)

CIRCUIT No.	PART No.	DESCRIPTION
	Choke colls	
L601-L603	230921R0	BLM21B222SPT
	Jack	
P601	25045441	Headphone jack, YKB26-5801
	Other	
P602	25051107	Wire holder, NSCT-3P894

MECHANISM ASSEMBLY

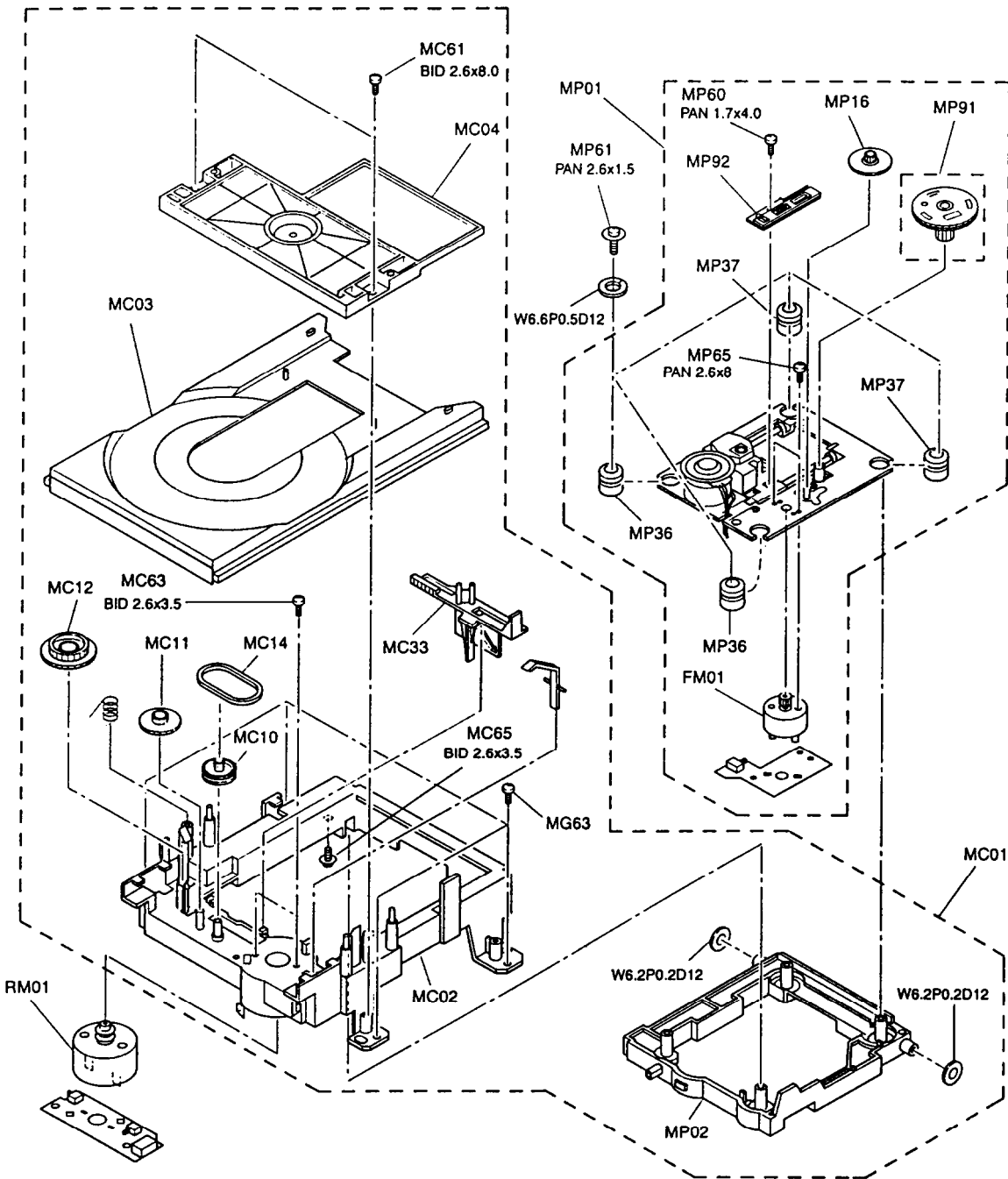

MECHANICAL PARTS LIST

REF. No.	CORD	DESCRIPTION
MP01	79070415	Mecha assy-pu
MP36	79070417	Rubber, Dumper, Front
MP37	79070418	Rubber, Dumper, Rear
MP91	79070419	Gear assy, Kit, B
MP92	79070420	Gear assy, Rack
FM01	79070421	Motor assy, Feed, DC
MP16	79070422	Gear A
RM01	79070427	Motor assy, Loading, DC
MC14	79070428	Belt, Load
MC01	79070416	Chassis assy, Mechanism

MAIN PC Board

EU01	79083019	PC Board assy Main PCB
------	----------	------------------------

1. REPLACEMENT OF MECHANICAL PARTS

Cabinet Replacement

1-1. Top Cover

1. Remove the top cover.

1-2. Clamper Stay

<Removal>

1. Remove two screws(1).
2. Release two claws and remove the clamper stay(2).

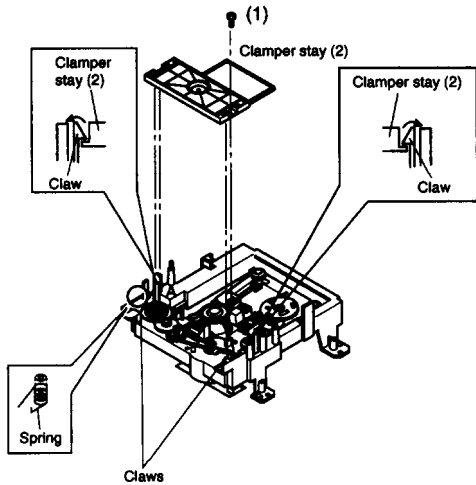

Fig.1-1

<Mounting>

3. The spring for tray side pressure is inserted into the portion "A".
4. By referring to Fig 1-2, insert the spring normally and mount the clamper stay.

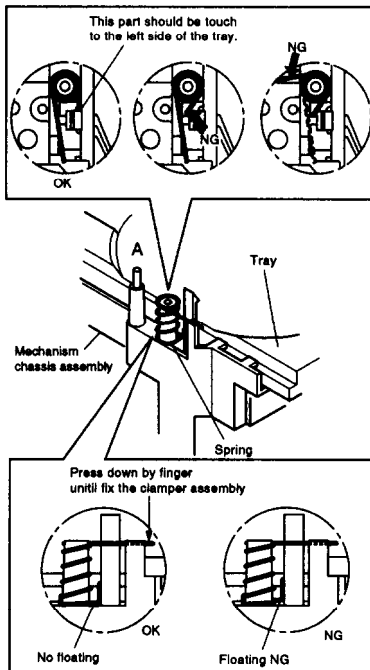

Fig. 1-2

1-3. Tray Eject

1. Slide the slider(2) of the mechanism chassis assembly (1) with a screwdriver, etc. in the arrow direction, so that the tray(3) is ejected.

Note:

Take care not to damage the pickup and other parts.

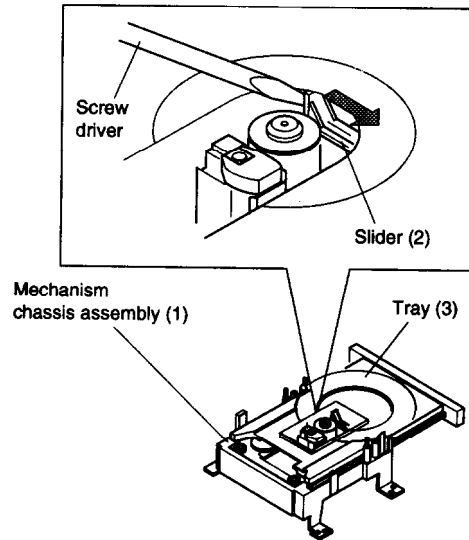

Fig. 1-3

1-4. Tray Panel Removal

1. Eject the tray(3).
2. Twist the tray panel(4) a little in the arrow A direction with the tray(3) hole by hand to release two claws and lift up tray panel (4) in the arrow B direction, then the tray panel(4) is removed.

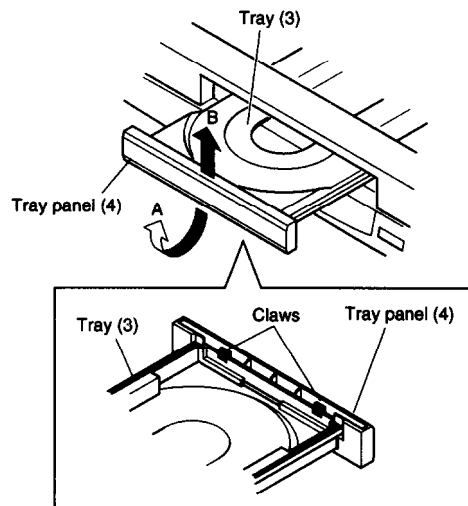

Fig. 1-4

Note

Insert the tray(3) with the front side of the pickup mechanism assembly descended. (The slider position to the left side.)

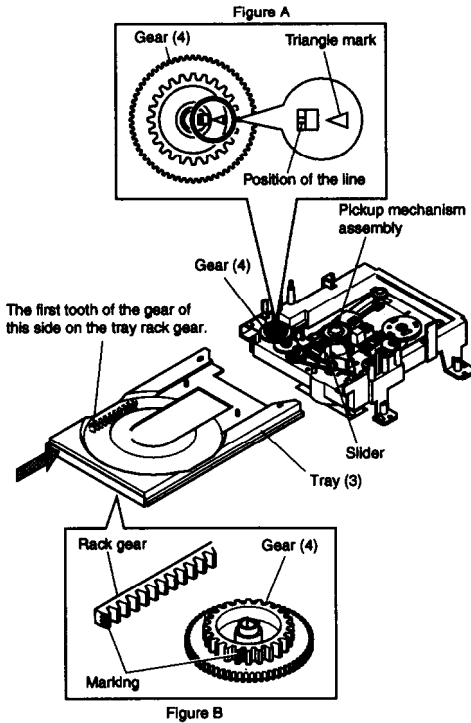

Fig. 1-5

1-5. PC Board Replacement

1. Before removing the main PC board, be sure to short-circuit the laser diode output land. After replacing, open the land as it was after inserting the flexible cables.
2. Remove six flexible cables and remove one connector.
3. Remove four screws.
4. Release two claws and remove the main PC board.

Mechanism Parts

2-1. Loading Belt

1. Remove the gear(1) by releasing the claw.
2. Remove the gear(2).
3. Remove the gear(3) and the loading belt(4).
4. Replace the loading belt(4) with a new one.
5. when mounting, perform the reverse order of the removal.

Note:

When mounting the loading belt(4), twisting and attaching of a grease, etc. not allowed.

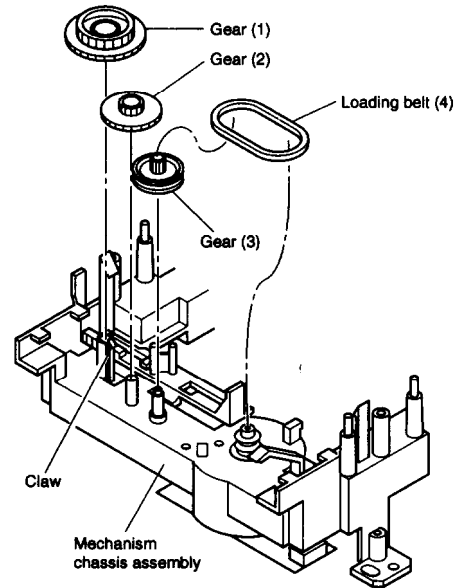

Fig. 2-1

2-2. Loading Motor

1. Remove the loading belt.
2. Remove two screw(1) and two claws. Then remove the loading motor(2)(with the loading motor PC board(3) attached).
3. Desolder the terminal section of the loading motor(2)
4. Replace the loading motor(2) with a new one.
5. When mounting, perform the reverse order of the removal.

Note:

When replacing the loading motor, meet the polarity phase of the terminals.

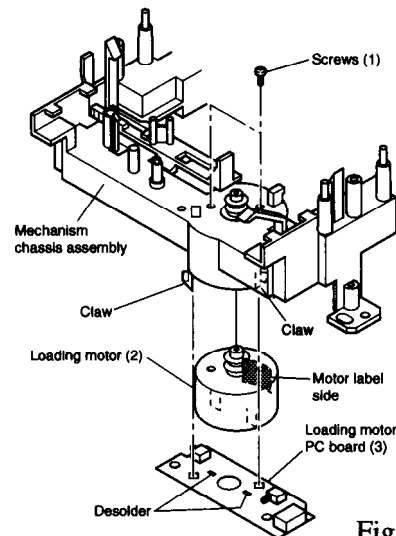

Fig. 2-2

2-5. Gear B Assembly, Gear A and Rack Gear Assembly

<Removal>

1. Release one claw and remove the gear B assembly (1).
2. Remove the gear A (2).
3. Remove one screw (3) and remove the rack gear assembly (4).

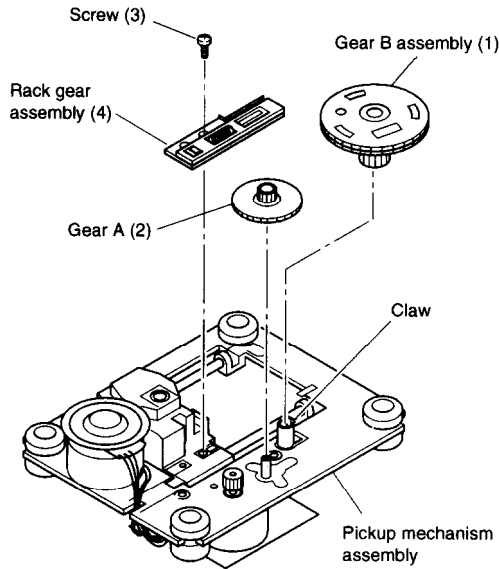

Fig. 2-5-1

<Mounting>

1. When mounting, perform the reverse order of the removal.
2. Mount the gear B assembly (1) by pushing the pickup head (5) to the disc motor side (arrow A direction) and shifting the upper gear of the rack gear assembly (4) in the arrow B direction.
3. Fit the positioning holes on the upper gear and lower gear of the gear B assembly (1) and mount on the pickup mechanism assembly with the phase matched. At this time, note that the phase of the gear B assembly (1) and the gear A (2) show's the status in the Fig. 2-5-3.

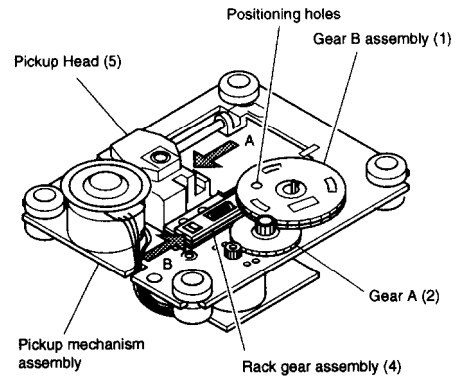

Fig. 2-5-2

Note:

- Mount the gear B assembly (1) and the gear a (2) with their gear teeth placed more than on tooth at least inside the shaded portion.

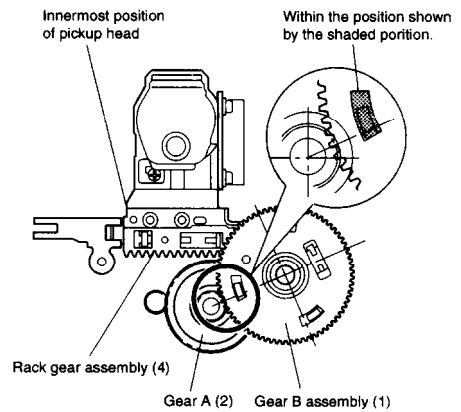

Fig. 2-5-3

2-6. Feed Motor

<Removal>

1. Remove the gear B assembly (1) and the gear A (2).
2. Remove two screws (1) and remove the feed motor (2) (with the feed motor PC board (3) attached.)
3. Desolder the terminals of the feed motor (2) and remove the feed motor PC board (3).

<Mounting>

1. Tighten the feed motor (2) on the pickup mechanism assembly with two screws (1).
2. Insert the feed motor PC board (3) with the positioning pin on the chassis matched and solder the terminals.
3. Perform the reverse order of the removal.

Note:

- After mounting, put the lead wires through the notch of the pickup mechanism assembly.
- When replacing the loading motor, meet the polarity phase of the terminals.

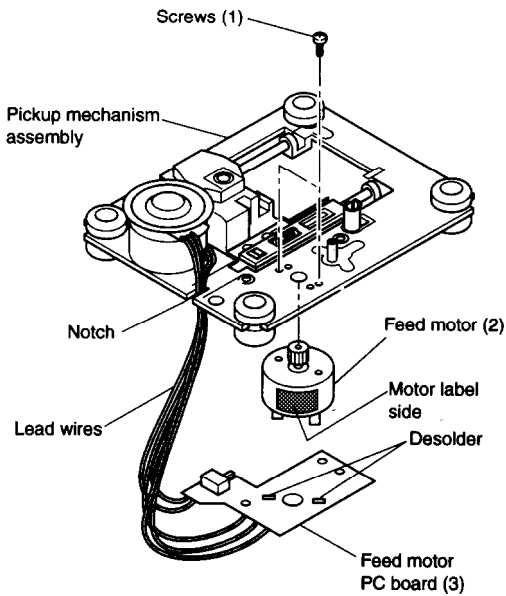

Fig. 2-6

3. TROUBLESHOOTING

3-1. Servo System

(1) Initial Operation after Power ON

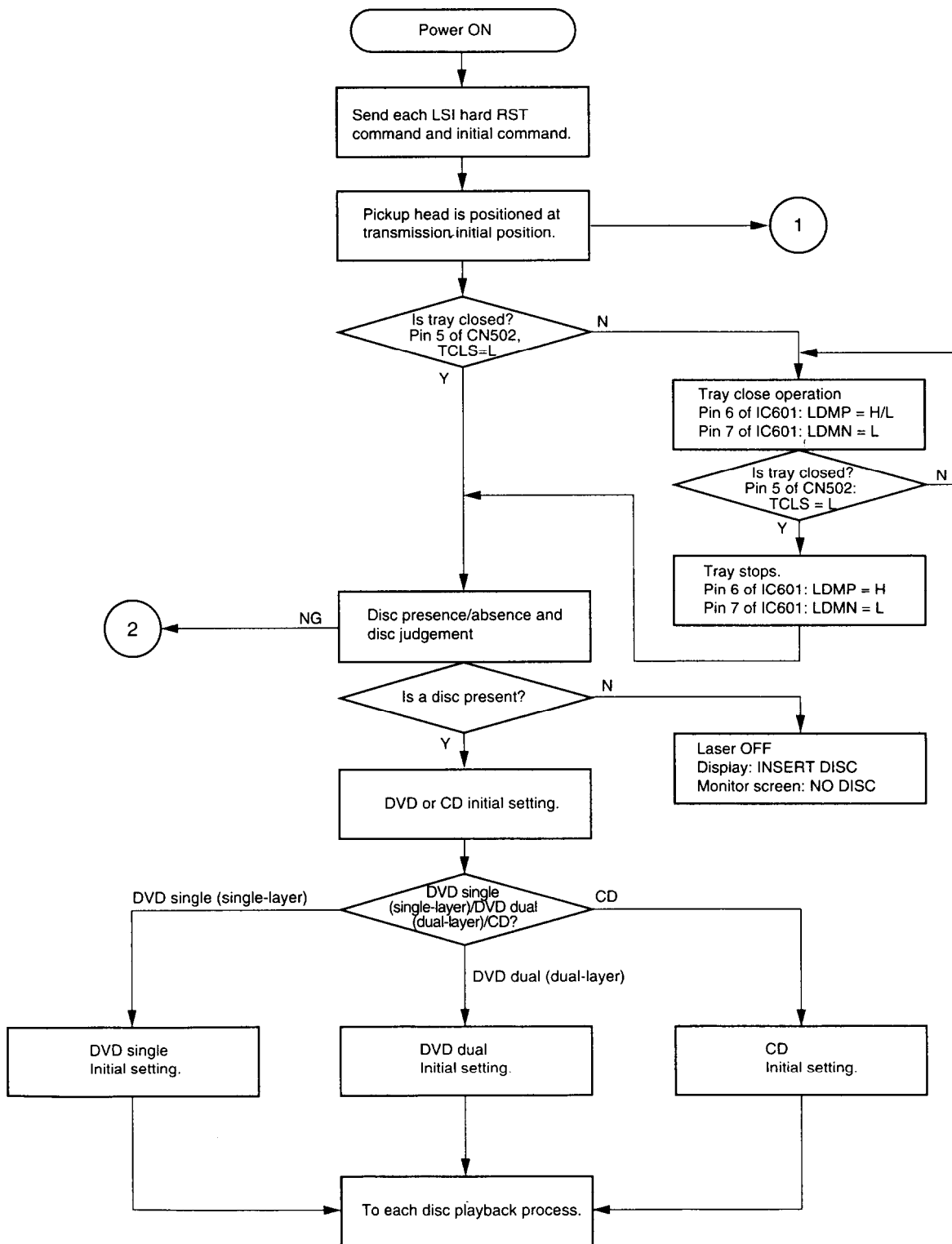

Fig.3-1

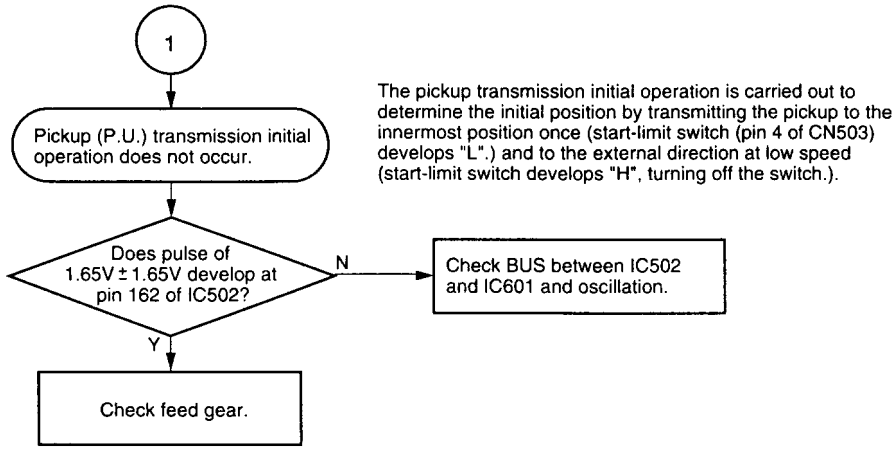

Fig. 3-2

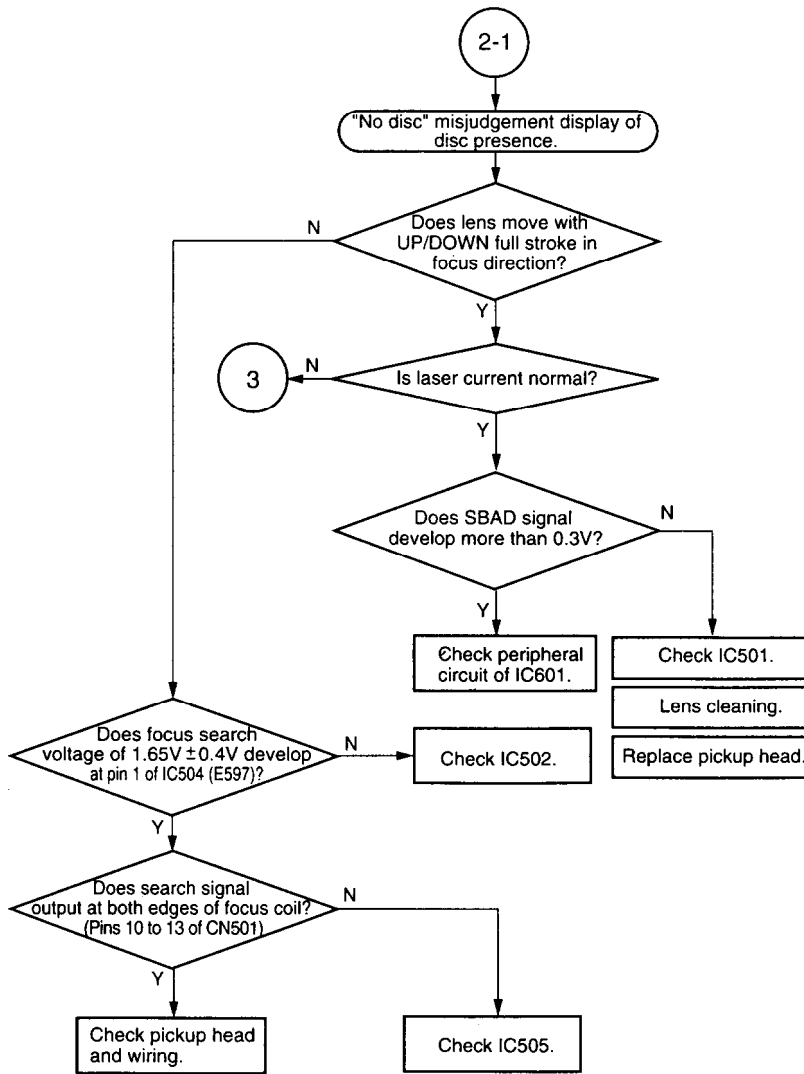

Fig. 3-3

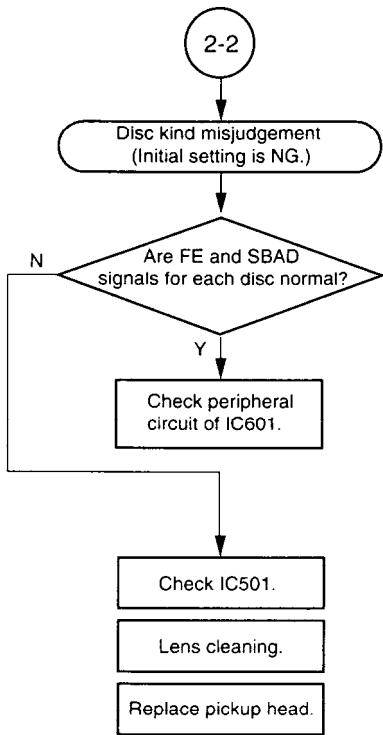

Fig. 3-4

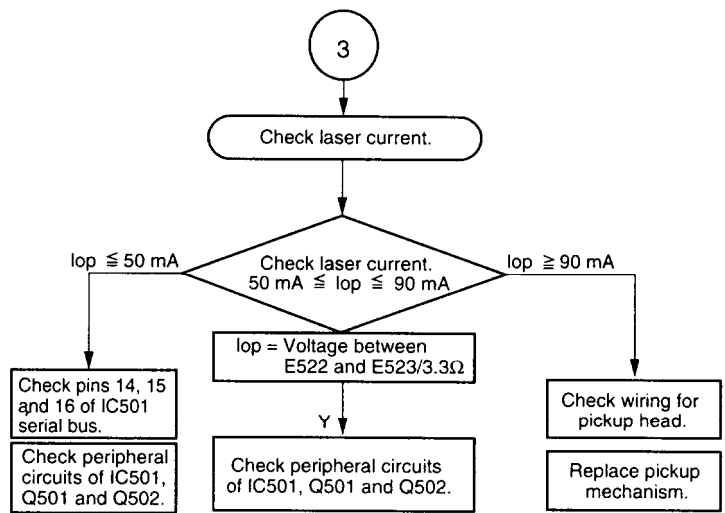

Fig. 3-5

DVD single (single-layer) disc
detection waveform

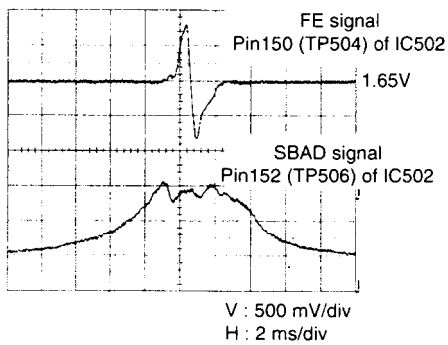

Fig. 3-6

DVD dual (dual-layer) disc
detection waveform

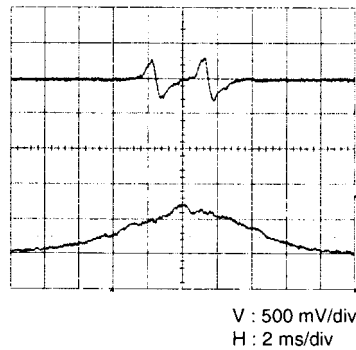

Fig. 3-7

CD disc
detection waveform

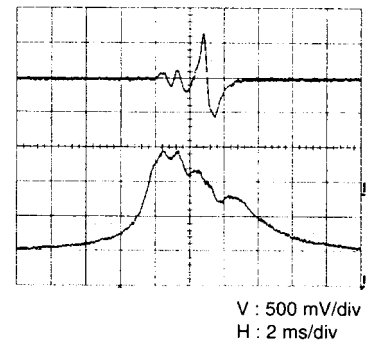

Fig. 3-8

(2) Picture appears (PLAY)

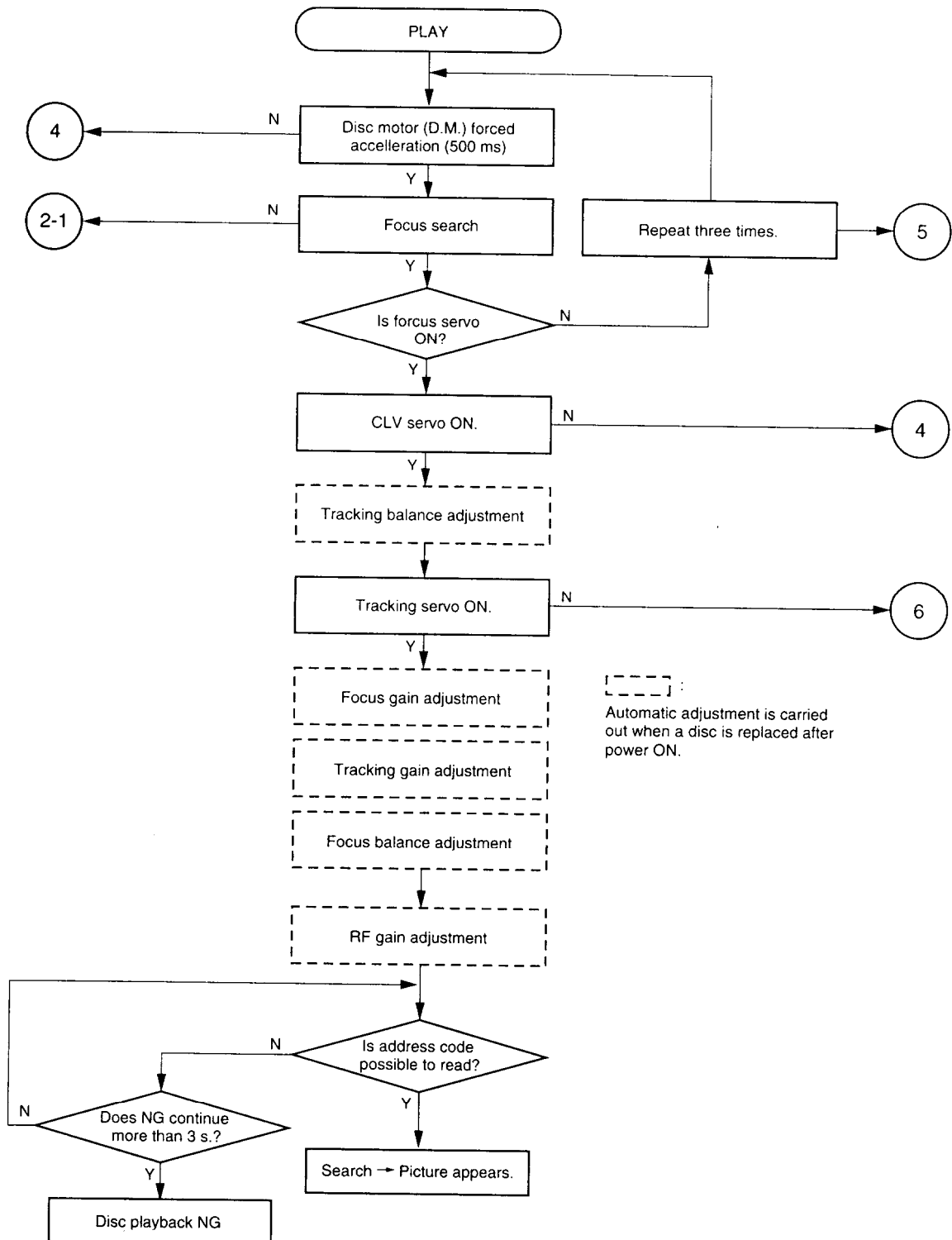

Fig. 3-9

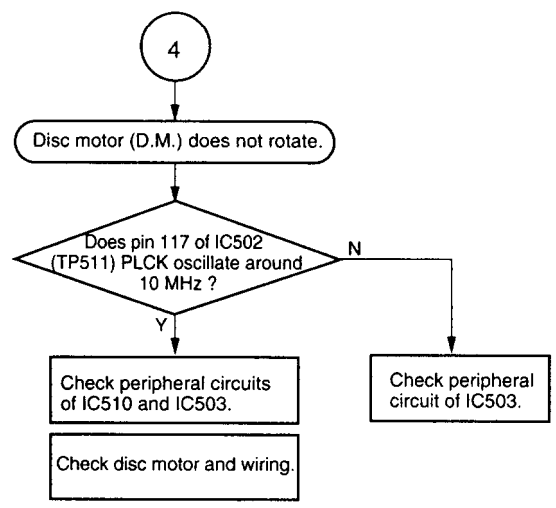

Fig. 3-10

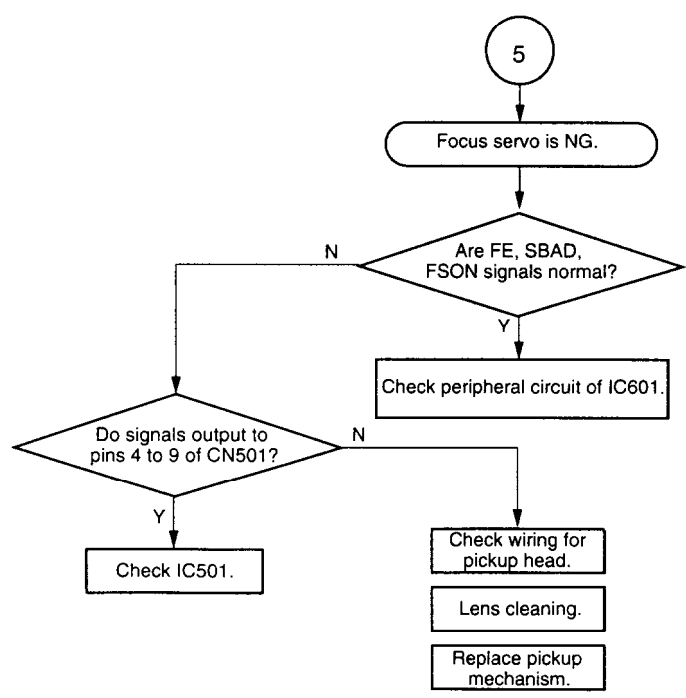

Fig. 3-11

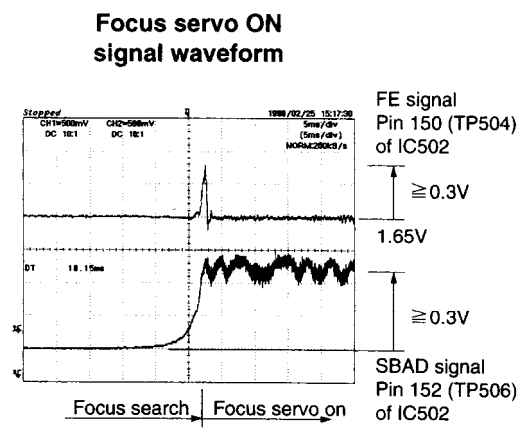

Fig.3-12

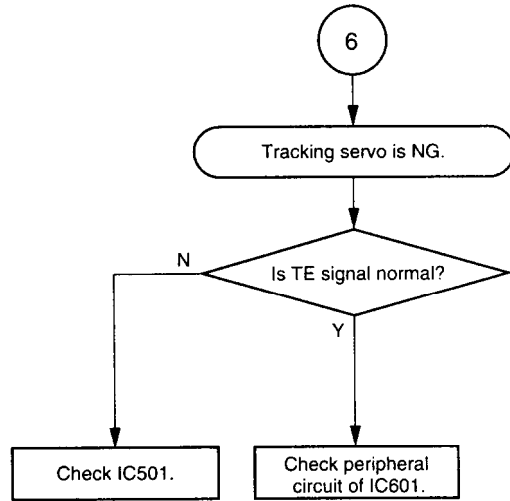
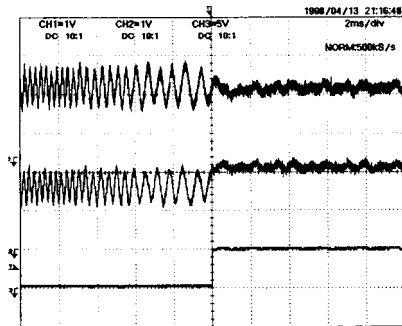

Fig. 3-13

Signal waveform at tracking servo ON (CD)



TE signal
Pin 151 (TP503) of IC502
1.65V

RFRP signal
Pin 153 (TP501) of IC502

Search ON (SRCH)
Pin 38 (TP508) of IC502

Filter: CH1: 0.00V Main: 10K Mode: NORMAL
Smoothing: OFF CH2: 0.00V Zoom: 2.5K Type: EDGE CH3: \neq
BW: FULL CH3: -0.10V Delay: 0.0ns
CH4: 5.20V Hold Off: MINIMUM

ON search | Tracking servo on

Fig. 3-14

Signal waveform at tracking servo ON (DVD)

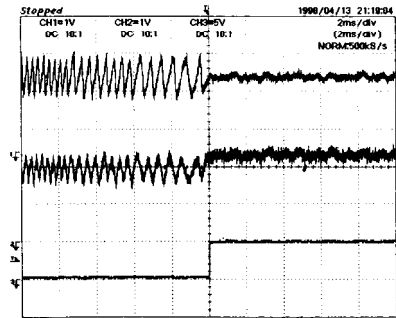

Filter: CH1: 0.00V Main: 10K Mode: NORMAL
Smoothing: OFF CH2: 0.00V Zoom: 2.5K Type: EDGE CH3: \neq
BW: FULL CH3: -0.10V Delay: 0.0ns
CH4: 5.20V Hold Off: MINIMUM

Fig.3-15

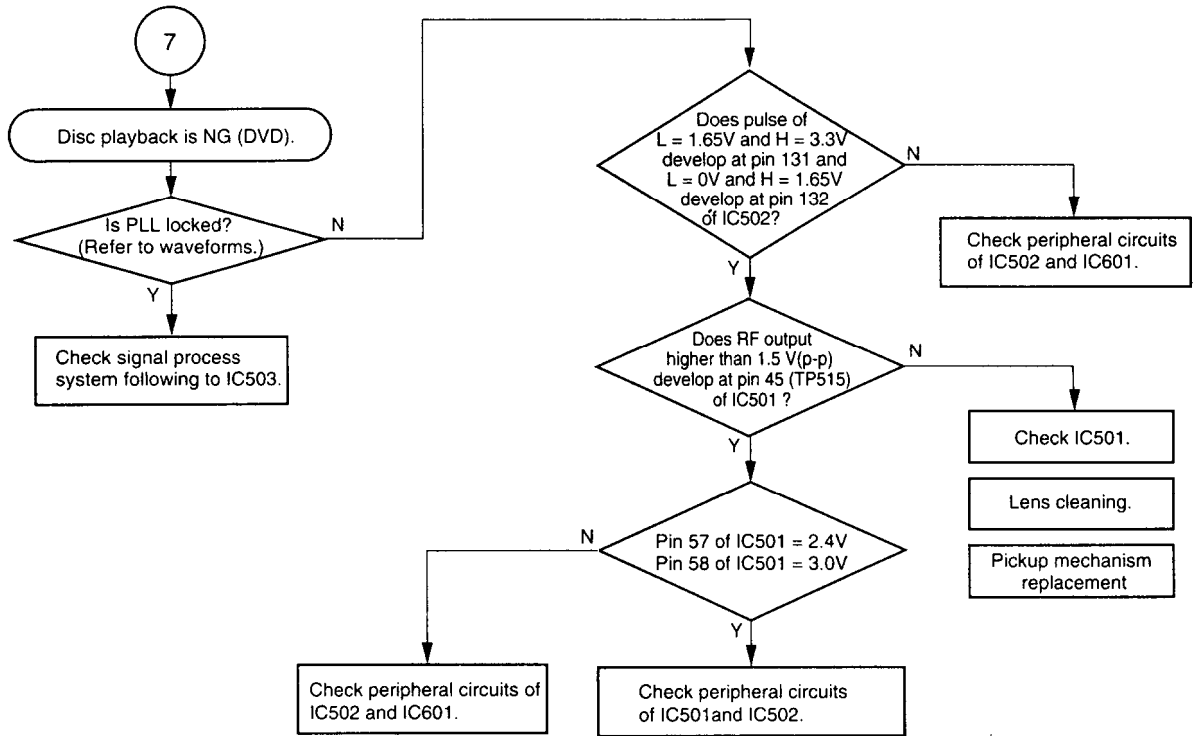

Fig. 3-16

PLL works as a servo loop to generate a clock signal for reading RF signal binary data. With the PLL locked, the eye pattern is identified clearly when triggered with the read clock PLCK.

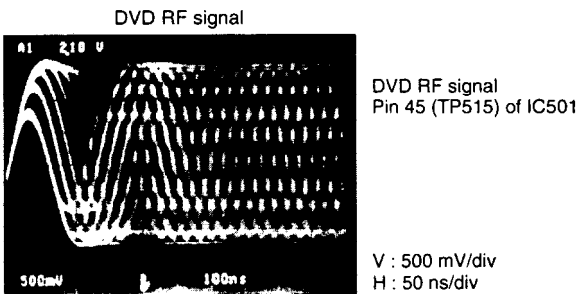

Fig. 3-17

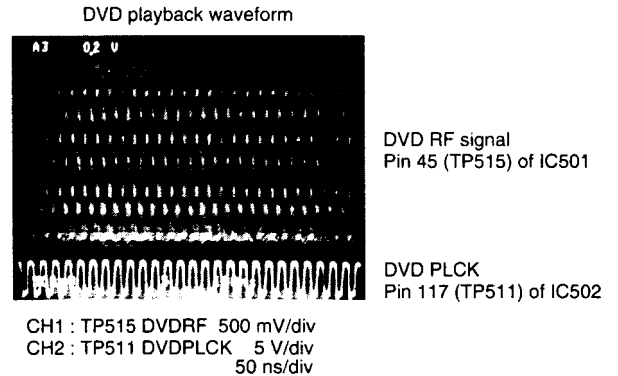

Fig. 3-19

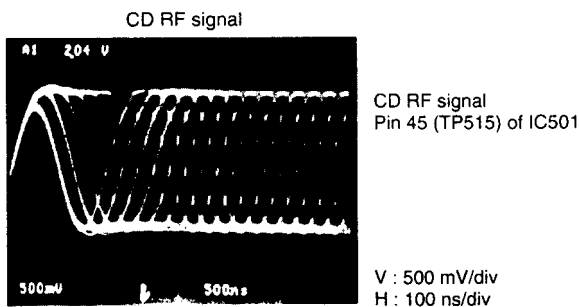

Fig.3-18

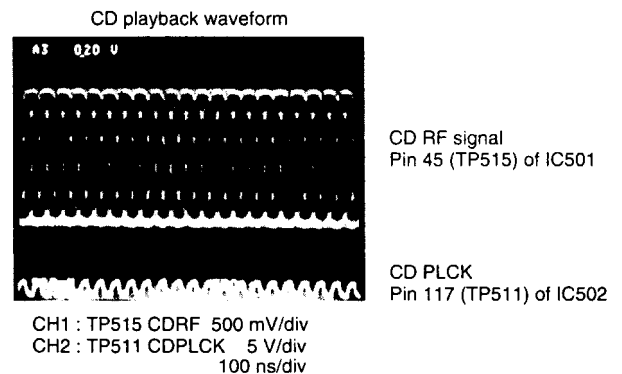

Fig. 3-20

(3) Location Diagram of Servo Test Point

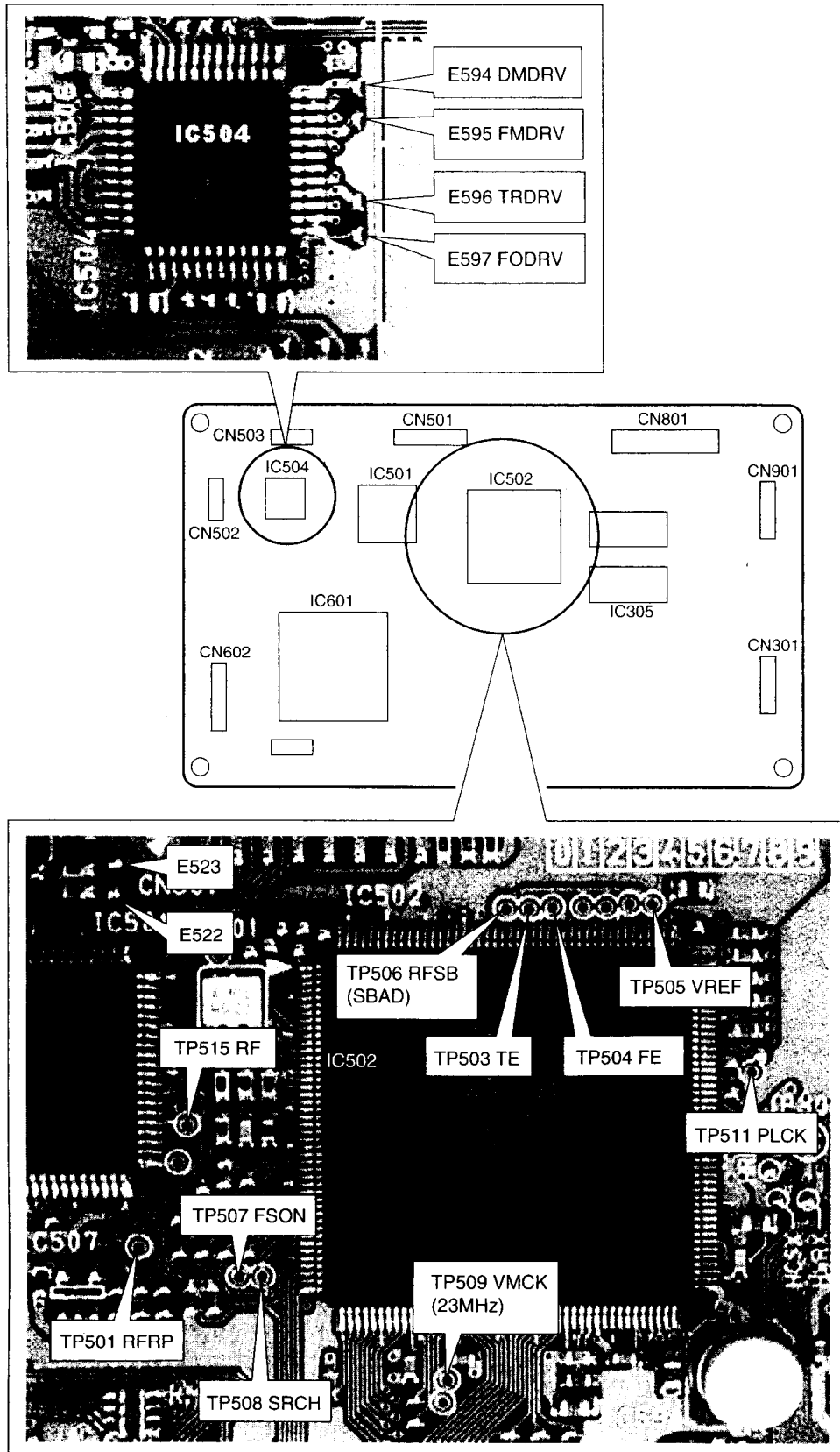

Fig. 3-21

WIRING DIAGRAM

