

ONKYO SERVICE MANUAL

DVD PLAYER MODEL DV-SP500

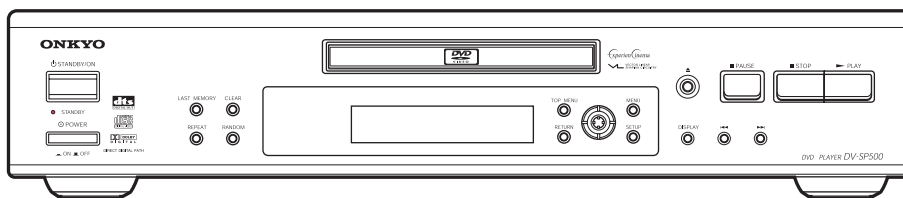

RC-449DV
U.S.A., Canadian
models only



RC-450DV
Other models

Black, Silver and Golden models

B MDD, B MDC	120V AC, 60Hz
B MUT, B MUS, B MUP	110 - 240V AC, 50/60Hz
G MUT, G MUS, G MUR, G MUK	
S MUP	

SAFETY-RELATED COMPONENT WARNING!!

THE MARK  FOUND ON SOME COMPONENT PARTS INDICATES THE CRITICAL FOR RISK OF FIRE AND ELECTRIC SHOCK.

WHEN REPLACING, BE SURE TO USE PARTS OF IDENTICAL DESIGNATION.

MAKE LEAKAGE-CURRENT OR RESISTANCE MEASUREMENTS TO DETERMINE THAT EXPOSED PARTS ARE ACCEPTABLY INSULATED FROM THE SUPPLY CIRCUIT BEFORE RETURNING THE APPLIANCE TO THE CUSTOMER.

SPECIFICATIONS

General

Power supply	AC 100 – 240 V, 50/60 Hz
Power consumption	15 W
Power consumption (standby mode)	2.6 W
Weight	3.4 kg
External dimensions	435 x 91 x 312 mm (W/H/D)
Signal system	PAL/Auto mode
Regional restriction code	U.S.A. and Canadian area 1 Asia, Oceania and Korea area 3 South American area 4 Chinese area 6

DVD Player

Laser	Semiconductor laser, wavelength 650 nm
Frequency range (digital audio)	DVD linear sound: 48 kHz sampling 4 Hz to 22 kHz 96 kHz sampling 4 Hz to 44 kHz Audio CD: 4 Hz to 20 kHz
Signal-to-noise ratio (digital audio)	More than 100 dB
Audio dynamic range (digital audio)	More than 96 dB
Harmonic distortion (digital audio)	Less than 0.015 %
Wow and flutter	Below measurable level (less than +/-0.001 % (W.PEAK))
Operating conditions	Temperature: 5°C to 35°C, Operation status: Horizontal

Outputs

Video output	1.0 V (p-p), 75 ohm negative sync., pin jack x 1, SCART socket x 1
S-video output	(Y) 1.0 V (p-p), 75 ohm negative sync., Mini DIN 4-pin x 1 (C) 0.286 V (p-p), 75 ohm SCART socket x 1 <MUP> only
Component video output	RGB signal output, 0.7 V (p-p), 75 ohm SCART socket x 1 <MUP> only
Audio output (digital output Optical)	Optical connector x 1
Audio output (digital output Coaxial)	0.5 V (p-p), 75 ohm pin jack x 1
Audio output (analog audio)	2.0 V (rms), 470 ohm pin jack (L, R) x 1, SCART socket x 1 <MUP> only 2.0 V (rms), 470 ohm pin jack (MONO) x 1



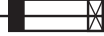

Specifications and features are subject to change without notice.

SERVICE PROCEDURES-1

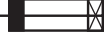
1. Replacing the fuses

 This symbol located near the fuse indicates that the fuse used is show operating type, For continued protection against fire hazard, replace with same type fuse , For fuse rating, refer to the marking adjust to the symbol.

 Ce symbole indique que le fusible utilise est e lent. Pour une protection permanente, n'utiliser que des fusibles de meme type. Ce demier est indique la qu le present symbol est apposse.

REF. NO.	PART NO.	DESCRIPTION
FI	252152 or 	1.6A-T/UL-ST2 or
	252147 	1.6A-TSC, Fuse <MDD/MDC>
	252273 or 	1.6A-SE-TL250V or
	252073 	1.6A-SE-EAK Fuse <MUP,MUS,MUT,MUR,MUK>
NOTE :	<MDD,MDC> : 120 V model only	
	<MUP,MUS,MUT,MUR,MUK> : 100 - 240 V model only	

2. Safety-check out

(Only U.S.A. model)

After correcting the original service problem perform the following safety check before releasing the set to the customer
Connect the insulating-resistance tester between the plug of power supply cord and terminal GND on the back panel.
Specifications: More than 10M ohm at 500V

3. LASER WARNING LABELS

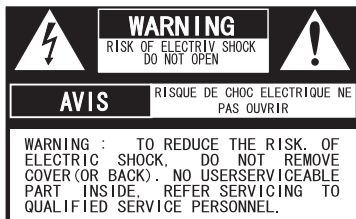

The lightning flash with arrowhead symbol, within an equilateral triangle, is intended to alert the user to the presence of uninsulated "dangerous voltage" within the product's enclosure that may be of sufficient magnitude to constitute a risk of electric shock to persons.



The exclamation point within an equilateral triangle is intended to alert the user to the presence of important operating and maintenance (servicing) instruction in the literature accompanying the appliance.

WARNING : TO REDUCE THE RISK OF FIRE OR ELECTRIC SHOCK, DO NOT EXPOSE THIS APPLIANCE TO RAIN OR MOISTURE. DANGEROUS HIGH VOLTAGES ARE PRESENT INSIDE THE ENCLOSURE. DO NOT OPEN THE CABINET. REFER SERVICING TO QUALIFIED PERSONNEL ONLY.

CAUTION : TO PREVENT ELECTRIC SHOCK, MATCH WIDE BLADE OF PLUG TO WIDE SLOT, FULLY INSERT.

ATTENTION : POUR EVITER LES CHOCS ELECTRIQUE, INTRODUIRE LA LAME LA PLUS LARGE DA LA FICHE DANS LA BORNE CORRESPONDANTE DA LA PRISE ET POUSSER JUSQU' AU FOND.



SERVICE PROCEDURES-2

4. Remove the solder of Laser Diode shorting

- 1-1 Connect Pickup and DVD main circuit PC board by FFC(3 pcs).
- 1-2 Fix it with the DVD Mechanism
- 1-3 Remove the solder of Laser Diode shorting on Pickup.
- 1-4 Connect total unit of DVD Mechanism (DVD Main PCB + Mechanism) to output terminal.

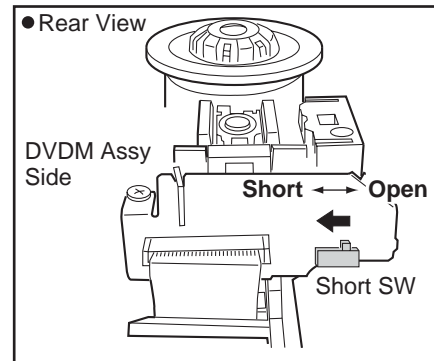

5. Key check mode

Press the [STOP] and [SKIP UP] keys at the same time .

FL display light up, and check the FL display. (about 2 second)

To cancel this process, Please press the [STOP] and [DISPLAY] keys at the same time again.

6. Factory setting **(Initial setting)**

3-1 Push the power switch "ON" (Mechanical switch)

3-2 Press the [STOP] and [STANDBY ON] keys at same time, and

it waits until the display of FL tube will be the display of "No Disc" from "Loading".

EXPLODED VIEW

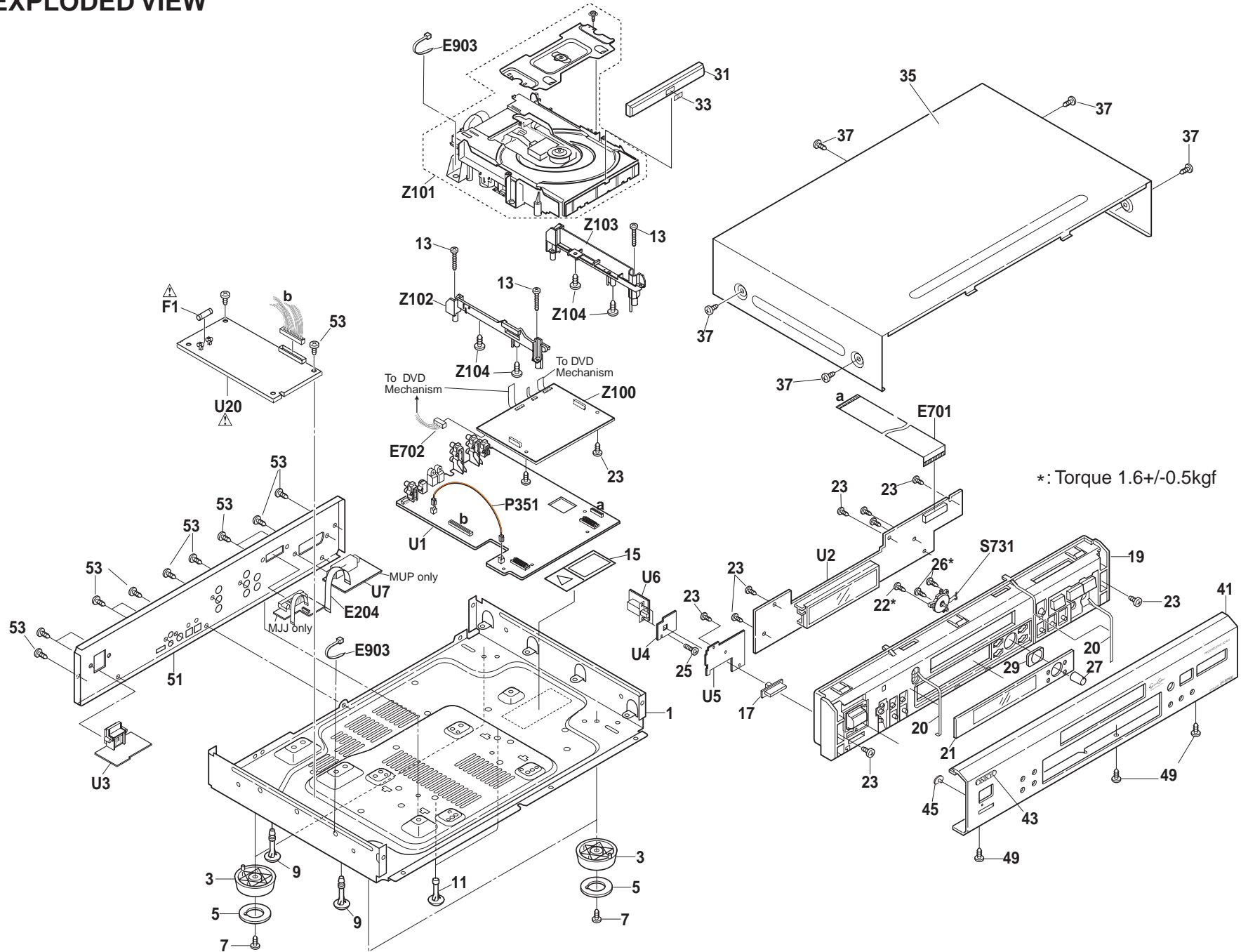

EXPLODED VIEW PARTS LIST-1

CHASSIS SECTION

REF. NO.	PART NO.	DESCRIPTION	REF. NO.	PART NO.	DESCRIPTION
1	27100399B	Chassis	51	27122992	Rear panel <B MDD/MDC>
3	27175316B	Leg		27122993	Rear panel <B MUT/G MUT/MUK>
5	28141332	Cushion		27122994	Rear panel <B MUS/G MUS>
7	838130088	3TTB+8B, Self tapping screw		27122995	Rear panel <G MUR>
9	27190428A	KGLS-10RF, Holder		27123015	Rear panel <B MUP/S MUP>
11	27191112	KGPS-6RF, Holder	53	838430088	3TTB+8B(BC), Self tapping screw
13	838130208	3TTB+20B, ST screw	E204	2047201512	Flexible flat cable, NCFC7-201512 <MUP/S MUP>
15	29362648	Label(DVD2)	E701	2045222012	NCFC5-222012, Flexible flat cable
17	28325497A	Knob, POWER 	E702	2009990691UL	NSAS-10P0959, Socket AS
	28325499A	Knob, POWER <G>	E903	260208	Wire tie
	28325547A	Knob, POWER <S>	F1	△252252	1.6A-T/UL-ST2 or
19	27111229	Front bracket 		△252147	1.6A-TSC, Fuse <MDD/MDC>
	27111231	Front bracket <G>		△252273	1.6A-SE-TL250V or
	27111230	Front bracket <S>		△252073	1.6A-SE-EAK IECEFUSE, Fuse
	29110161	Tape			<MUT/MUS/MUP/MUR/MUK>
21	28191926	Clear plate 	P351	2009990739UL	NSAS-4P1033, Socket AS
	28191927	Clear plate <G/S>	S731	25035710	NPS-115-S673, Joy stick switch
22	838426088	2.6TTB+8B(BC), Self tapping screw			
23	838130088	3TTB+8B Self tapping screw			
25	82143010	3P+10FN(BC), PAN head screw	U1	1H492505-1A	NAAR-7605-1A, Output terminal PC board assy <MDD/MDC>
26	838126068	2.6TTB+6B, Self tapping screw		1H492505-1B	NAAR-7605-1B, Output terminal PC board assy <MUT/MUK>
27	28325933	Knob, (CRS) 		1H492505-1C	NAAR-7605-1C, Output terminal PC board assy <MUS>
	28325935	Knob, (CRS) <G>		1H492505-1D	NAAR-7605-1D, Output terminal PC board assy <MUR>
	28325934	Knob, (CRS) <S>		1H492505-1F	NAAR-7605-1F, Output terminal PC board assy <MUP>
29	27268041	Guide, (CRS) 	U2	1H492506-1A	NADIS-7606-1A, Display circuit PC board assy <MDD/MDC>
	27268043	Guide, (CRS) <G>		1H492506-1B	NADIS-7606-1B, Display circuit PC board assy <MUT/MUK>
	27268042	Guide, (CRS) <S>		1H492506-1C	NADIS-7606-1C, Display circuit PC board assy <MUS>
31	28148479A	Door 		1H492506-1D	NADIS-7606-1D, Display circuit PC board assy <MUR>
	28148481A	Door <G>		1H492506-1F	NADIS-7606-1F, Display circuit PC board assy <MUP>
	28148480A	Door <S>			
33	27262651	Plate (DVD)			
35	28184808	Top cover 			
	28184780A	Top cover <G>			
	28184779A	Top cover <S>			
37	838930088	3TTB+8B(UN), Self tapping screw <G/S>			
	838430088	3TTB+8B(BC), Self tapping screw 			
41	27212406	Front panel <B,MDD/MDC/MUT/MUS>			
	27212407	Front panel <G MUT/MUS/MUR/MUK>			
	27212433	Front panel <B MUP>			
	27212426	Front panel <S MUP>			
43	28135244	Badge 			
	28135245	Badge <G/S>			
45	28198906	Facet (S)			
49	838430088	3TTB+8B(BC), Self tapping screw			

**NOTE: THE COMPONENTS IDENTIFIED BY MARK △
ARE CRITICAL FOR RISK OF FIRE AND
ELECTRIC SHOCK. REPLACE ONLY WITH
PART NUMBER SPECIFIED.**

EXPLODED VIEW PARTS LIST-2

CHASSIS SECTION

REF. NO.	PART NO.	DESCRIPTION	REF. NO.	PART NO.	DESCRIPTION
U3	1H492510-1A	NAPS-7610-1A, AC inlet terminal PC board assy <MDD/MDC>	U20	△ 24150020A	NGPS-0020-120V, Power supply unit <MDD/MDC>
	1H492510-1B	NAPS-7610-1B, AC inlet terminal PC board assy <MUT/MUK>		△ 24150021A	NGPS-0021-100V-240V, Power supply unit <MUT/MUS/MUR/MUK/MUP>
	1H492510-1C	NAPS-7610-1C, AC inlet terminal PC board assy <MUS>	Z100	24150028	DB-VPB306, Main circuit PC board assy <MDD/MDC/MUT/MUS/MUR/MUK>
	1H492510-1D	NAPS-7610-1D, AC inlet terminal PC board assy <MUR>		24150019	DB-VPB301, Main circuit PC board assy <MUP>
	1H492510-1F	NAPS-7610-1F, AC inlet terminal PC board assy <MUP>	Z101	24801010	DB-VLD301, DVD Mechanism assy
U4	1H492511-1A	NAETC-7611-1A, Support PC board <MDD/MDC>	Z102	24840149A	DB-VAC301, Adapter L
	1H492511-1B	NAETC-7611-1B, Support PC board <MUT/MUK>	Z103	24840150A	DB-VAC302, Adapter R
	1H492511-1C	NAETC-7611-1C, Support PC board <MUS>	Z104	838130088	3TTB+8B, Self tapping screw
	1H492511-1D	NAETC-7611-1D, Support PC board <MUR>			<MDD> : U.S.A. model only
	1H492511-1F	NAETC-7611-1F, Support PC board <MUP>			<MDC> : Canadian model only
U5	1H492512-1A	NADIS-7612-1A, Standby LED PC board assy <MDD/MDC>			<MUT> : Asia model, regional code 3, video code PAL
	1H492512-1B	NADIS-7612-1B, Standby LED PC board assy <MUT/MUK>			<MUS> : South American model, regional code 4, video code PAL
	1H492512-1C	NADIS-7612-1C, Standby LED PC board assy <MUS>			<MUR> : Chinese model only
	1H492512-1D	NADIS-7612-1D, Standby LED PC board assy <MUR>			<MUK> : Korea model, regional code 3, video code PAL
	1H492512-1F	NADIS-7612-1F, Standby LED PC board assy <MUP>			<MUP> : European model only
U6	1H492513-1A	NASW-7613-1A, Power switch PC board assy <MDD/MDC>			 : Black color model
	1H492513-1B	NASW-7613-1B, Power switch PC board assy <MUT/MUK>			<G> : Golden color model
	1H492513-1C	NASW-7613-1C, Power switch PC board assy <MUS>			<S> : Silver color model
	1H492513-1D	NASW-7613-1D, Power switch PC board assy <MUR>			
	1H492513-1F	NASW-7613-1F, Power switch PC board assy <MUP>			
U7	1H492514-1F	NAETC-7614-1F, SCART terminal PC board assy <MUP>			

NOTE: THE COMPONENTS IDENTIFIED BY MARK △ ARE CRITICAL FOR RISK OF FIRE AND ELECTRIC SHOCK. REPLACE ONLY WITH PART NUMBER SPECIFIED.

EXPLODED VIEW (LOADING MECHANISM) / PARTS LIST

Z101 : DVD Mechanism DB-VLD301

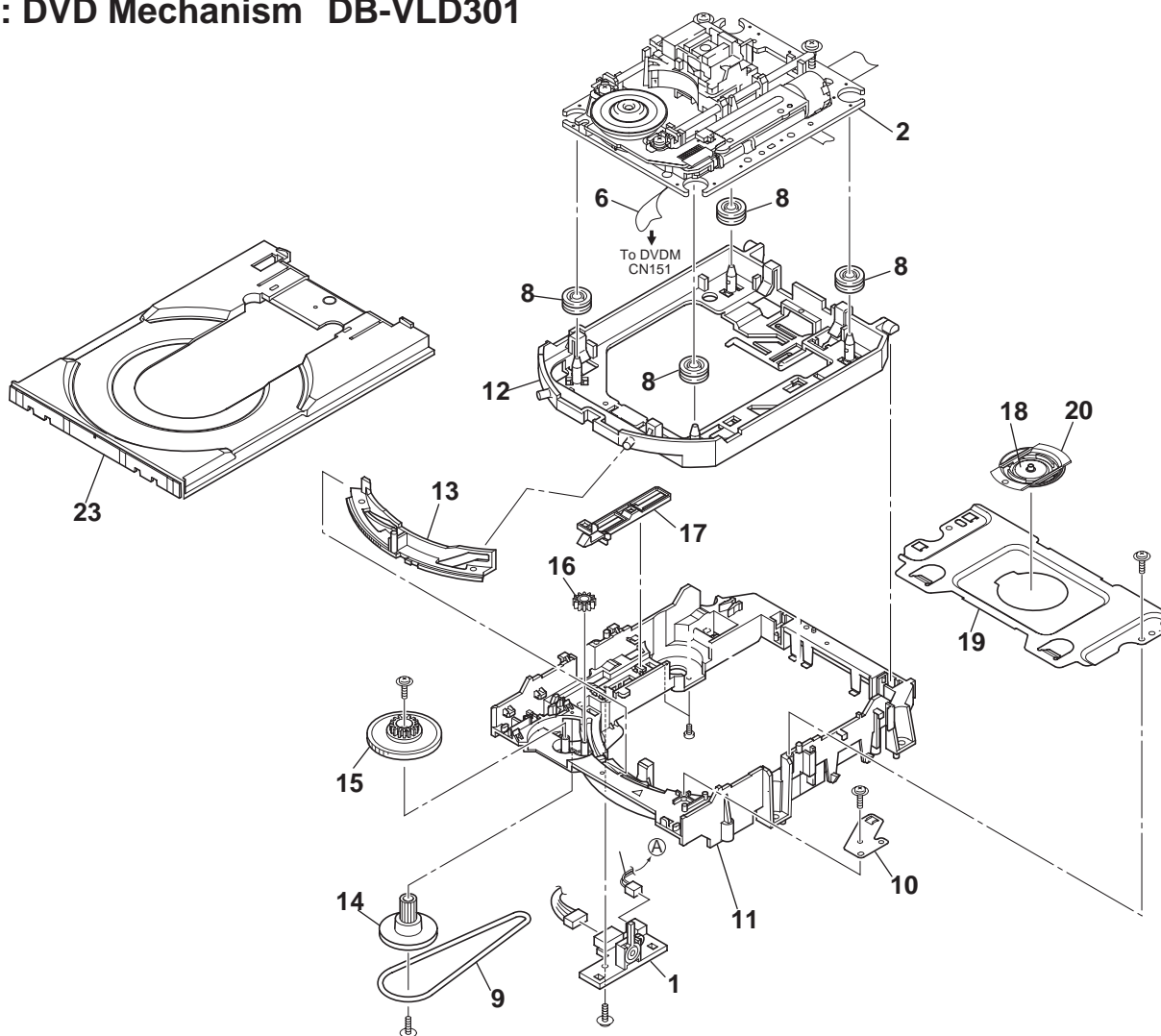

Parts list

REF.NO	PART NO.	DESCRIPTION	REF.NO.	PART NO.	DESCRIPTION
1	VNP1836	Loading PC board assy	12	VNL1918	Float base DVD
2	VXX2782	Traverse mechanism assy	13	VNL1919	Drive cam
6	VDA1864	FFC 26P	14	VNL1921	Gear pulley
8	VEB1327	Rubber	15	VNL1922	Loading gear
9	VEB1328	Belt	16	VNL1923	Drive gear
10	VNE2253	Stabilizer	17	VNL1925	Lever switch
11	VNL1917	Loading base	18	VNE2251	Clamber plate
			19	VNE2252	Bridge
			20	VNL1924	Clamber
			23	VNL1920	Tray

EXPLODED VIEW (LOADING MECHANISM) / PARTS LIST

Z101 : DVD Mechanism DB-VLD301

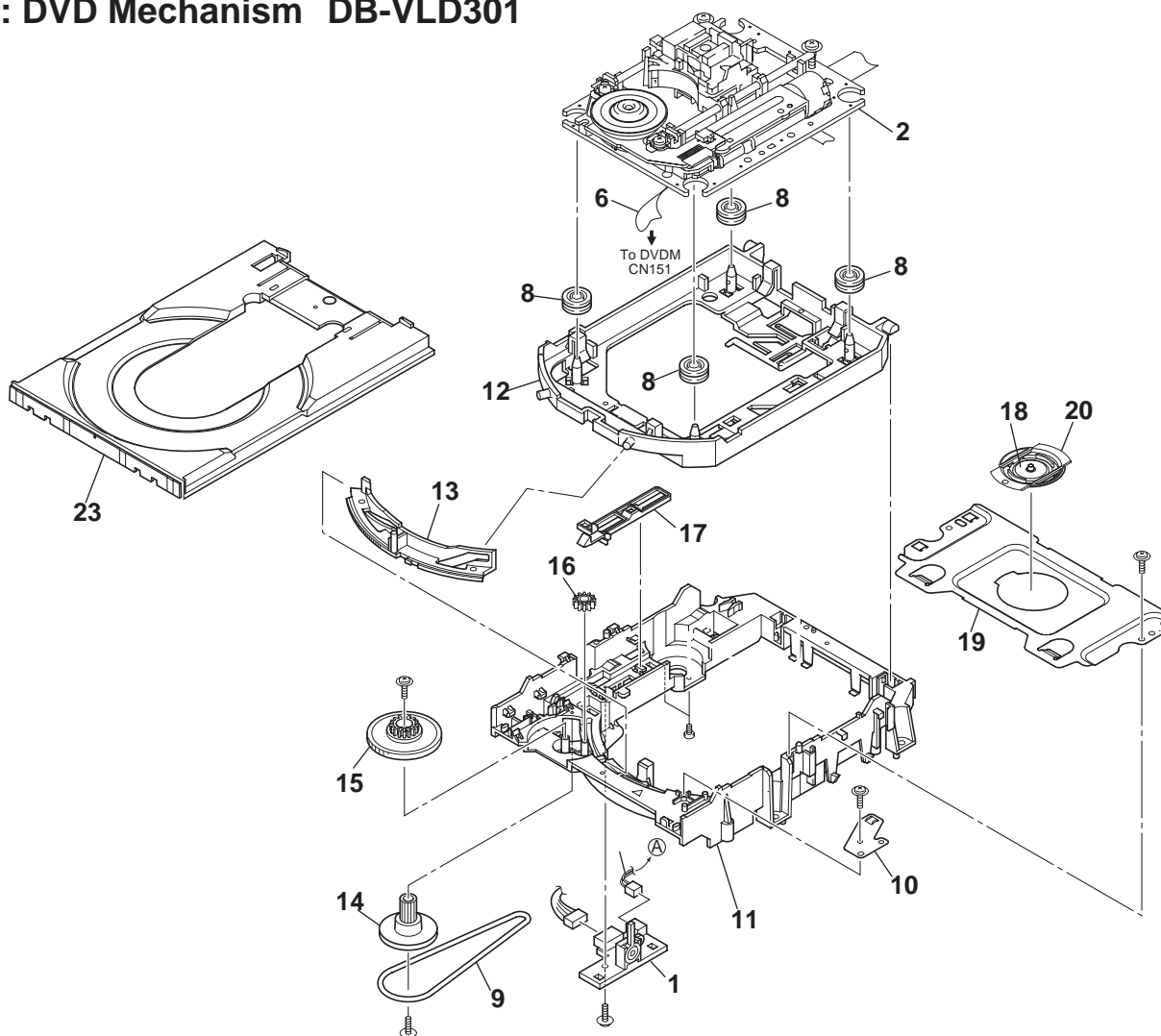

Parts list

REF.NO	PART NO.	DESCRIPTION	REF.NO.	PART NO.	DESCRIPTION
1	VNP1836	Loading PC board assy	12	VNL1918	Float base DVD
2	VXX2782	Traverse mechanism assy	13	VNL1919	Drive cam
6	VDA1864	FFC 26P	14	VNL1921	Gear pulley
8	VEB1327	Rubber	15	VNL1922	Loading gear
9	VEB1328	Belt	16	VNL1923	Drive gear
10	VNE2253	Stabilizer	17	VNL1925	Lever switch
11	VNL1917	Loading base	18	VNE2251	Clamber plate
			19	VNE2252	Bridge
			20	VNL1924	Clamber
			23	VNL1920	Tray

**EXPLODED VIEW / PARTS LIST
TRAVERSE MECHANISM ASSY**

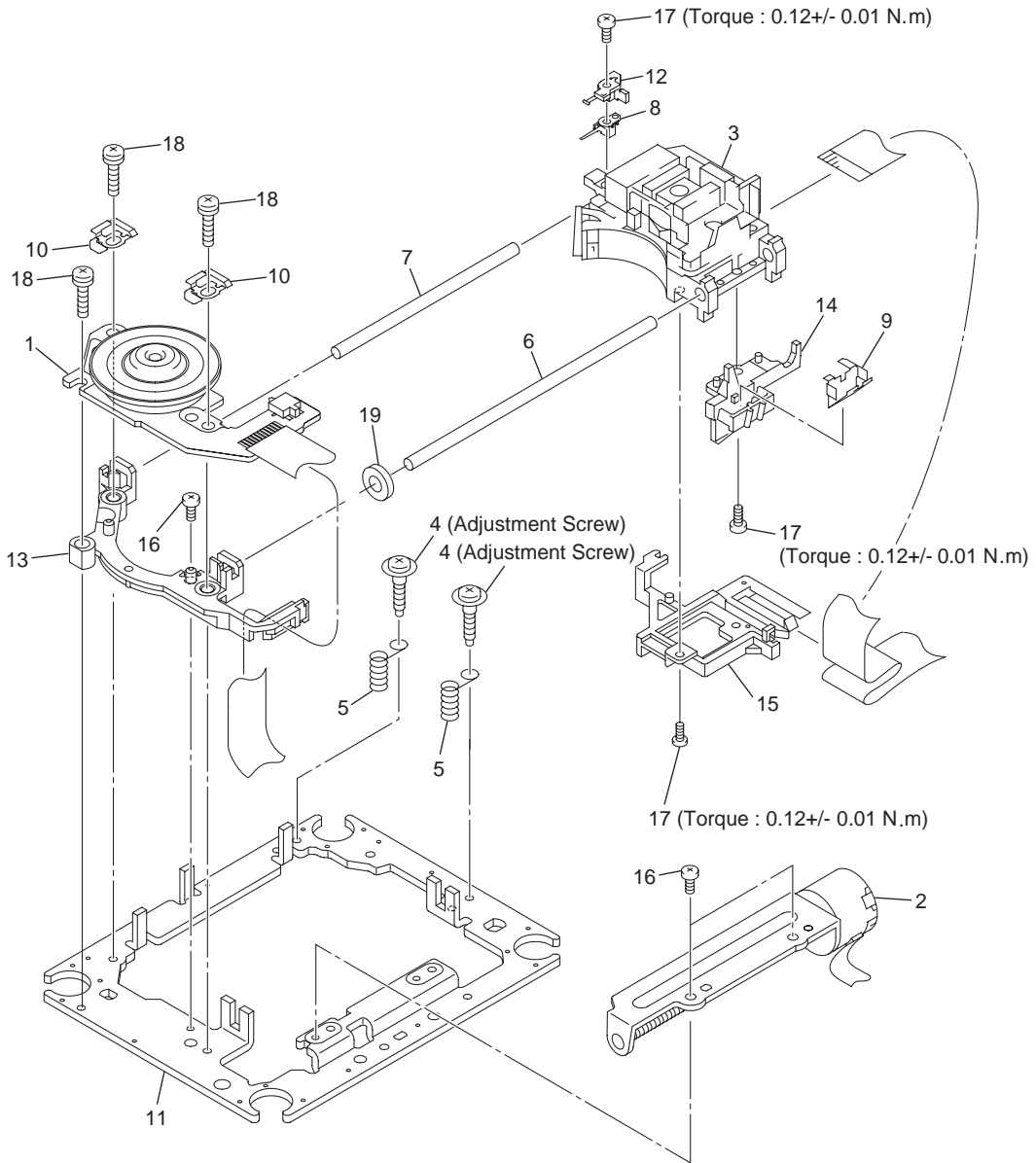

TRAVERSE MECHANISM ASSY-S PARTS LIST

Mark	No.	Description	Part No.	Mark	No.	Description	Part No.
	1	Spindle Motor	VXM1088 (or VXM1089)		9	Joint Spring	VNC1019
	2	Stepping Motor (CARRIAGE)	VXM1090 (or VXM1091)	NSP	10	Support Spring	VNC1020
	3	Pickup Assy-S	OXX8003		11	Mechanism Chassis	VNE2248
	4	Skew Screw	VBA1080		12	Slider	VNL1811
	5	Skew Spring	VBH1335		13	Spacer	VNL1913
	6	Guide Bar	VLL1514		14	Joint	VNL1914
	7	Sub Guide Bar	VLL1515		15	FFC Holder	VNL1915
	8	Hold Spring	VNC1017		16	Screw	BBZ20P050FZK
					17	Screw	OBA8009
					18	Screw	PMA26P100FMC
					19	Damper Sheet	VEB1335

NSP : Not service part

BLOCK DIAGRAM

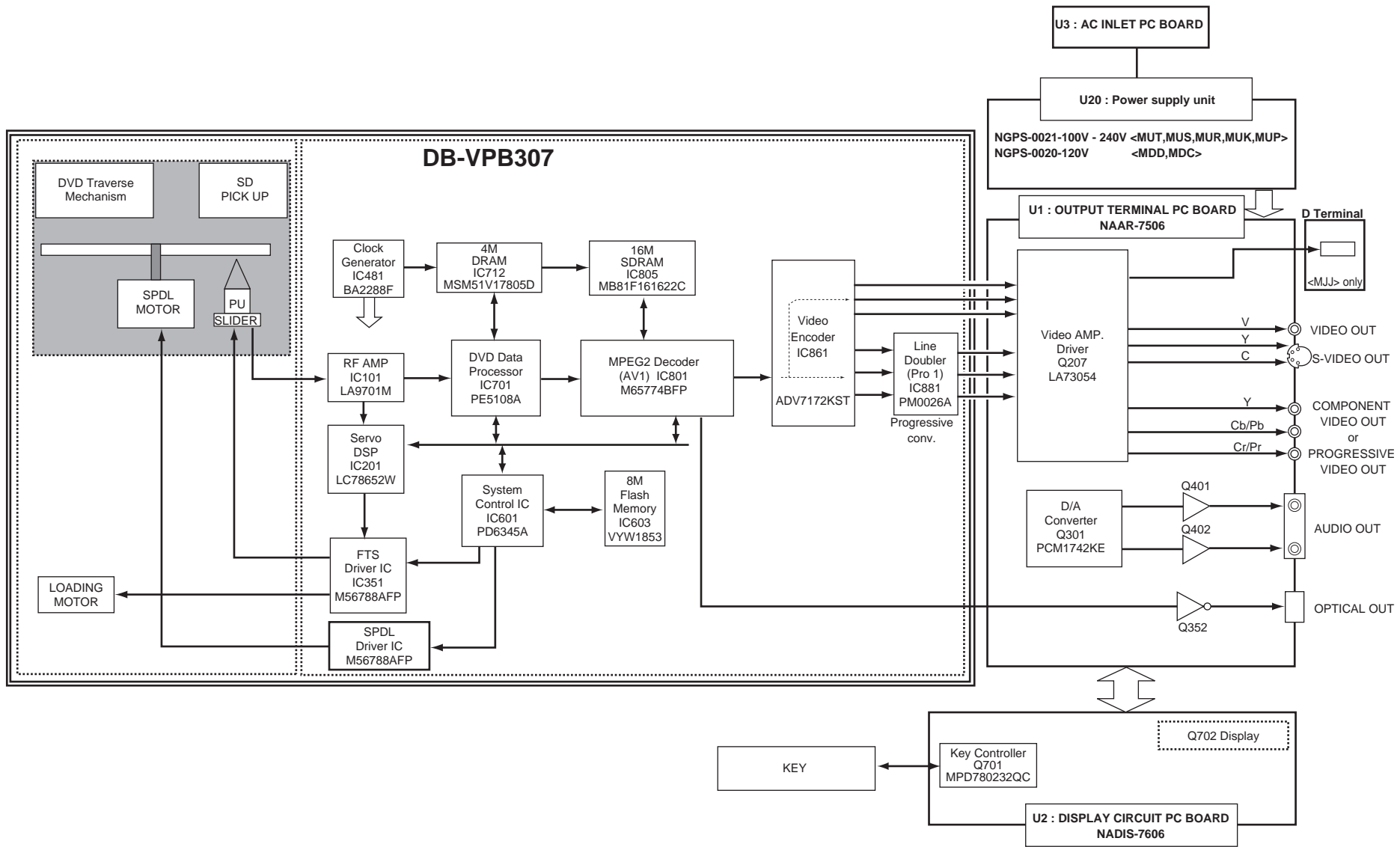

SCHEMATIC DIAGRAM -1

U1: OUTPUT TERMINAL PC BOARD

1
2
3
4
5

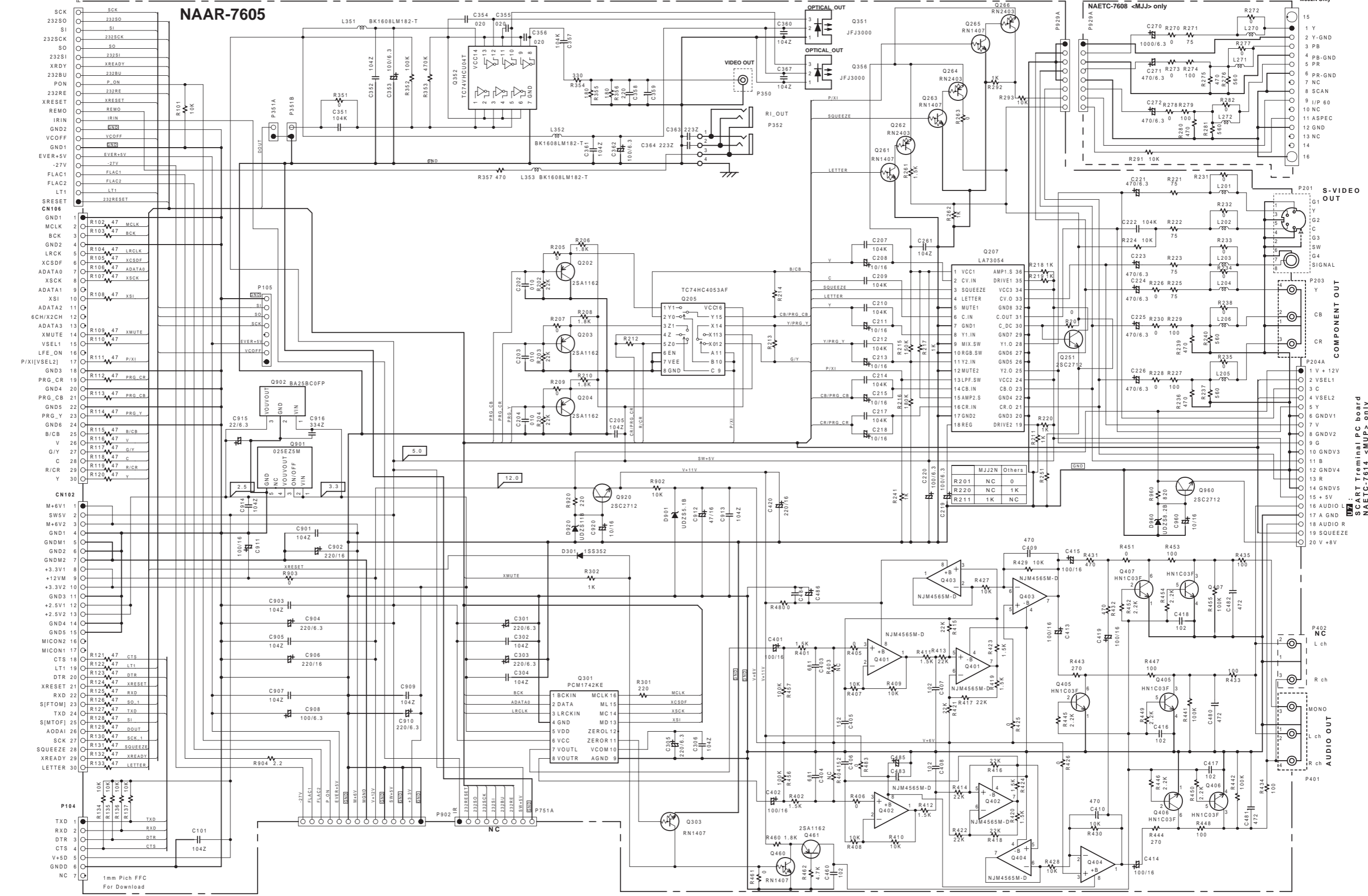

U1: SCART Terminal PC board NAETC-7614 <MUP> only

1mm Pitch FFC For Download

A

B

C

D

SCHEMATIC DIAGRAM -1

U1: OUTPUT TERMINAL PC BOARD

NAAR-7605

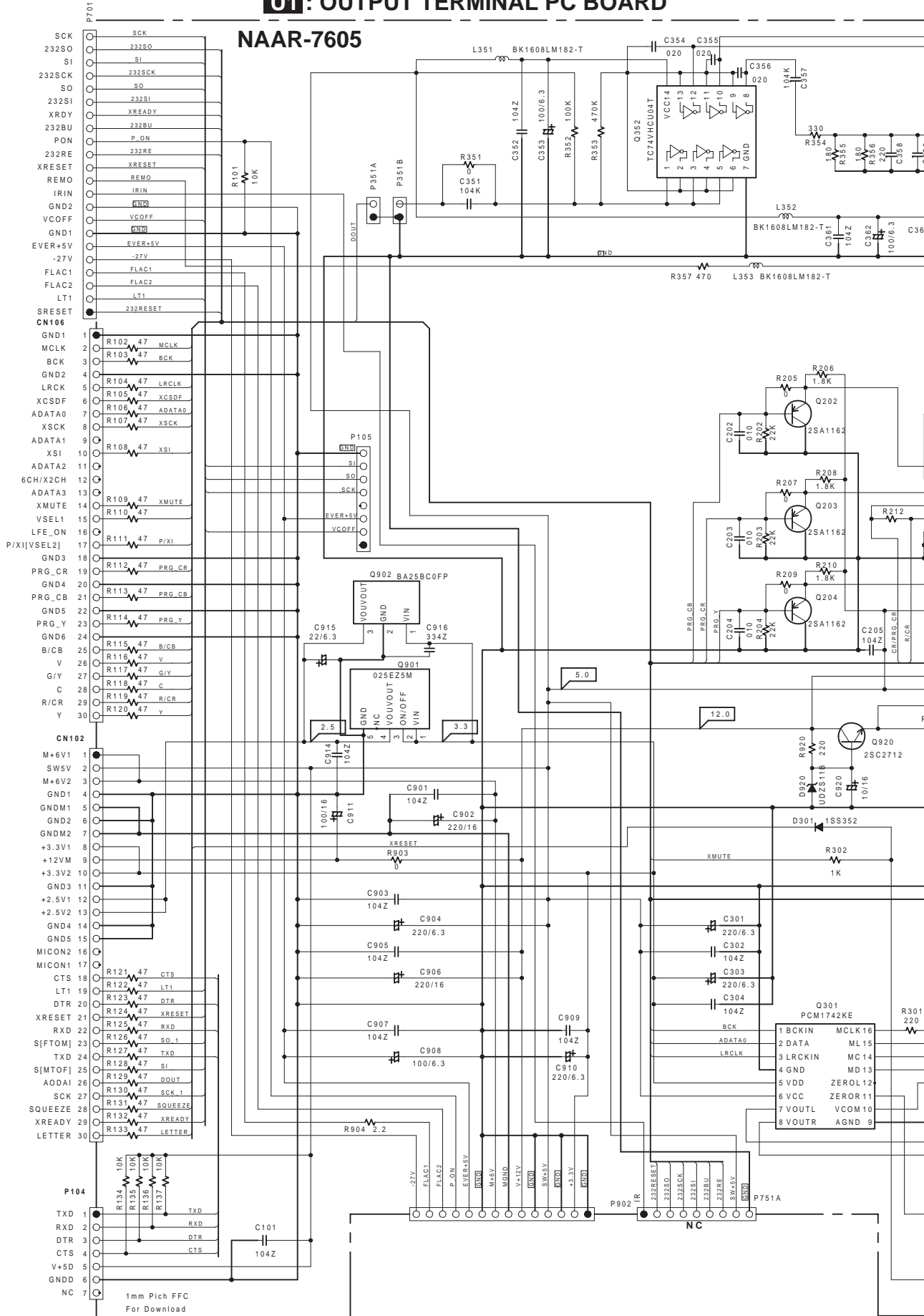

1

2

3

4

5

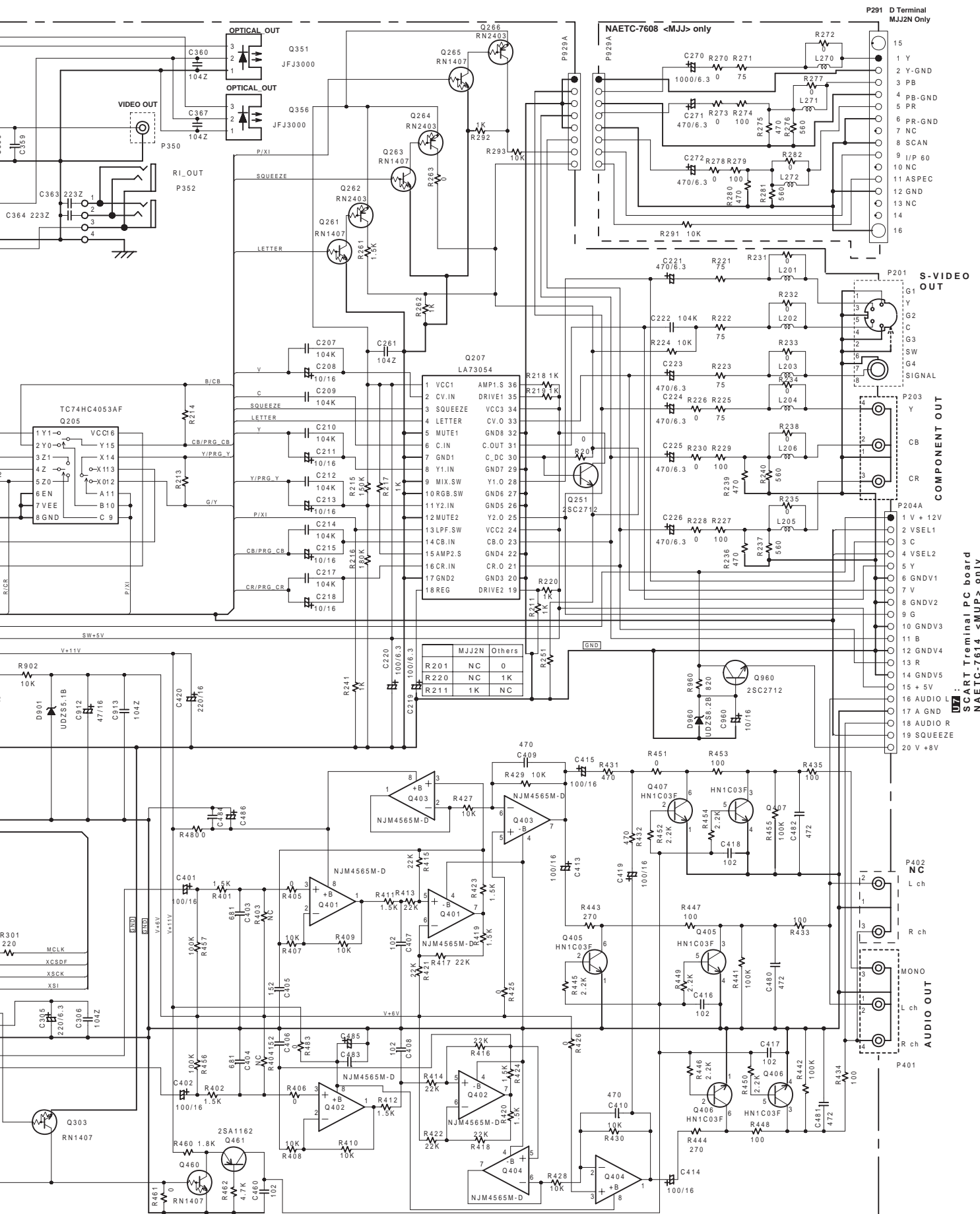

07 : SCART Terminal PC board
 NAETC-7614 <MUP> only

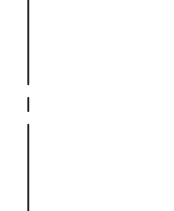
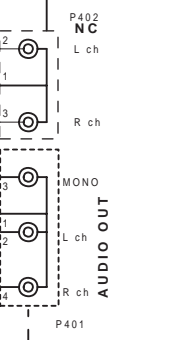
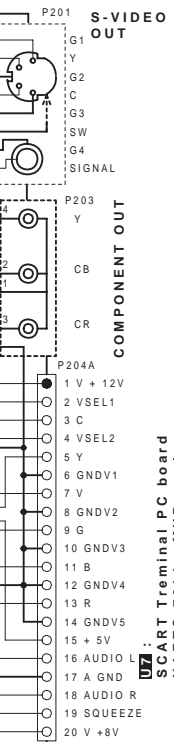
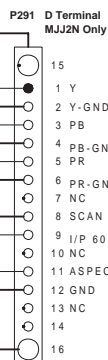

	MJJ2N	Others
R201	NC	0
R220	NC	1K
R211	1K	NC

E

F

G

H

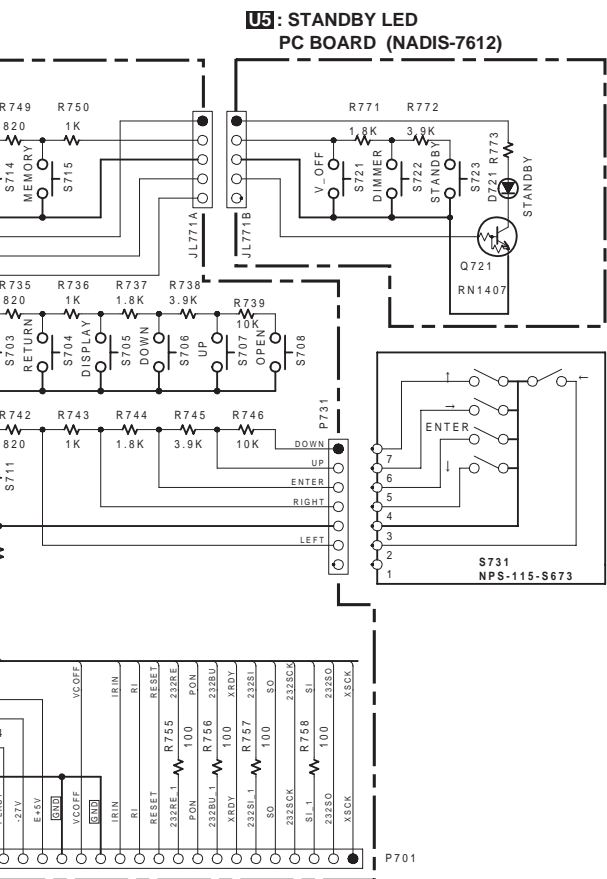

To NAAR-7605
Output terminal PC board

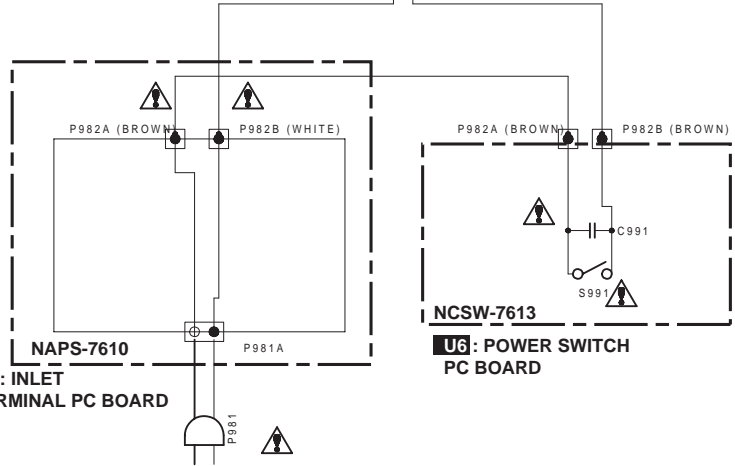
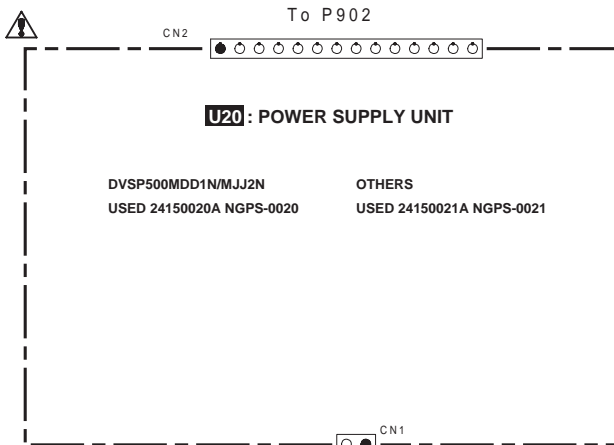

CAUTION



FOR CONTINUED PROTECTION AGAINST FIRE HAZARD, REPLACE ONLY WITH FUSE OF SAME TYPE AND RATING INDICATED.

ATTENTION



AFIN D'ASSURER UNE PROTECTION PERMANENTE CONTRE LES RISQUES D'INCENDIE, REMPLACER UNIQUEMENT PAR UN FUSIBLE DE MEME TYPE ET CALIBRATION COMME INDIQUE.



THIS SYMBOL LOCATED NEAR THE FUSE INDICATES THAT THE FUSE USED IS SLOW OPERATING TYPE FOR CONTINUED PROTECTION AGAINST FIRE HAZARD, REPLACE WITH SAME TYPE FUSE. FOR FUSE RATING REFER TO THE MARKING ADJACENT TO THE SYMBOL.



CE SYMBOLE INDIQUE QUE LE FUSIBLE UTILISE EST LENT. POUR UNE PROTECTION PERMANENTE, N'UTILISER QUE DES FUSIBLES DE MEME TYPE. CE DERNIER EST INDIQUE LA QU LE PRESENT SYMBOLE EST APPOSE.

COMPONENTS IDENTIFIED BY MARK ARE CRITICAL FOR SAFETY. ONLY WITH PART NUMBER SPECIFIED.
RESISTORS MEASURED WITH IS DC VOLTAGE. (NO INPUT SIGNAL)
CAPACITORS ARE IN uF/WV.
RESISTORS ARE IN pF/50WV UNLESS OTHERWISE NOTED.
RESISTORS 330 → 33pF 331 330pF 333 → 0.033uF
RESISTORS ARE IN OHMS 1/4 WATTS UNLESS OTHERWISE NOTED.
DIMENSION LINES ON PC BOARD ARE THE PRINTING SIDE OF THE PARTS.
PRINTING SIDE
SUBJECT TO CHANGE FOR IMPROVEMENT.

SCHEMATIC DIAGRAM - 2

1
2
3
4
5

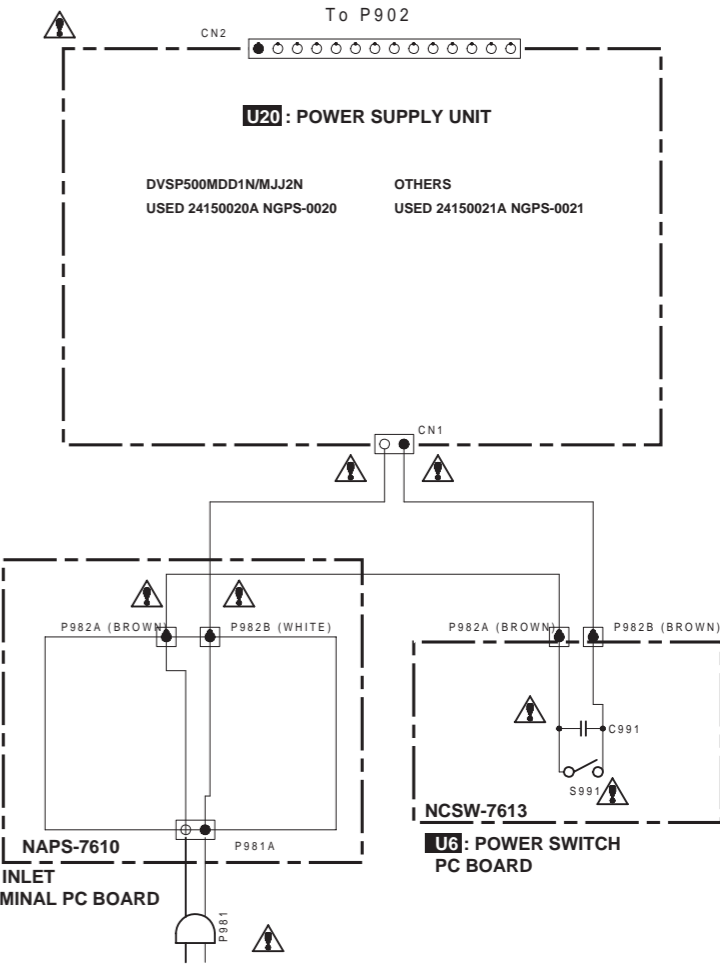
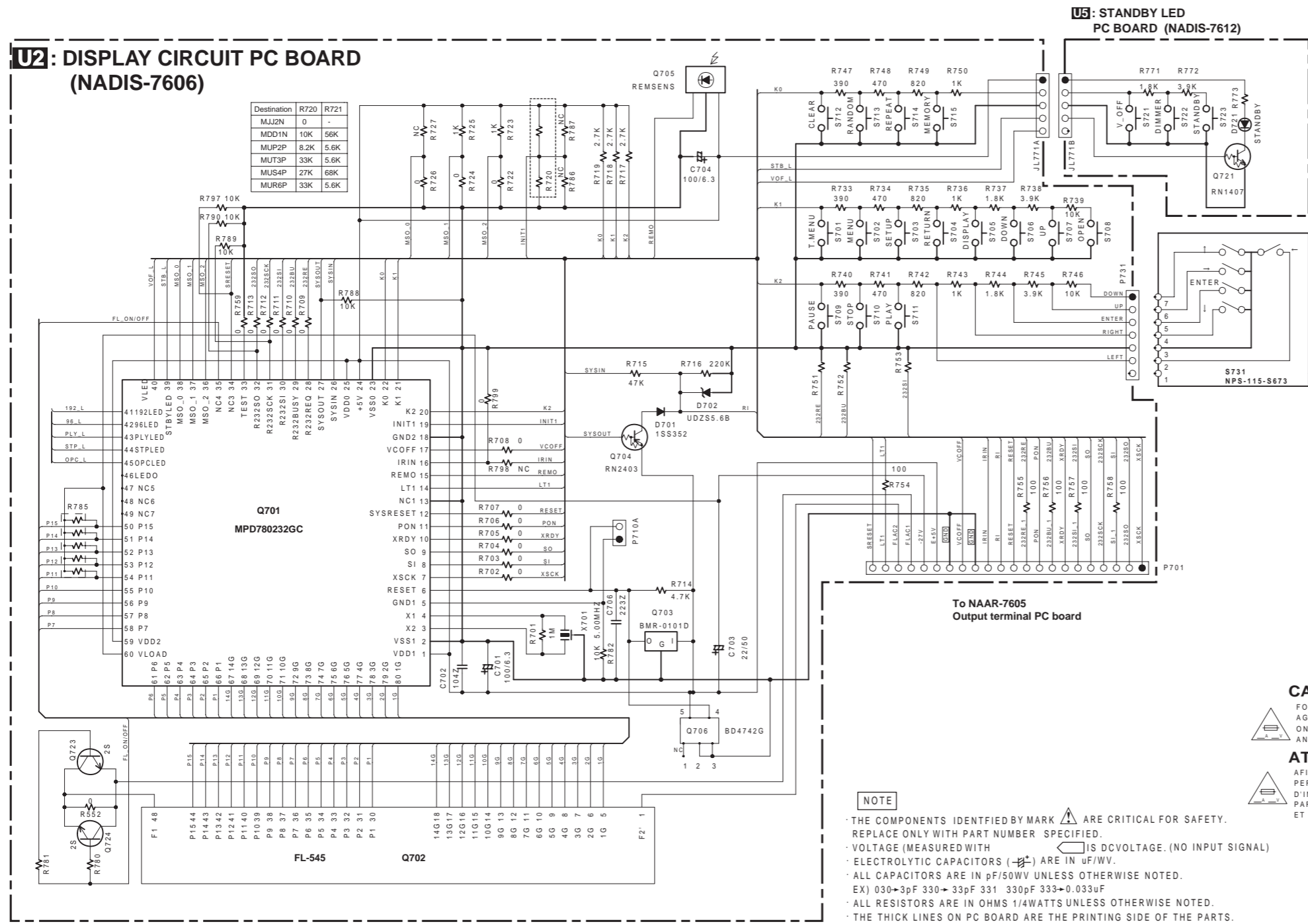

CAUTION
FOR CONTINUED PROTECTION AGAINST FIRE HAZARD, REPLACE ONLY WITH FUSE OF SAME TYPE AND RATING INDICATED.

ATTENTION
AFIN D'ASSURER UNE PROTECTION PERMANENTE CONTRE LES RISQUES D'INCENDIE, REMPLACER UNIQUEMENT PAR UN FUSIBLE DE MEME TYPE ET CALIBRATION COMME INDIQUE.

THIS SYMBOL LOCATED NEAR THE FUSE INDICATES THAT THE FUSE USED IS SLOW OPERATING TYPE FOR CONTINUED PROTECTION AGAINST FIRE HAZARD. REPLACE WITH SAME TYPE FUSE. FOR FUSE RATING REFER TO THE MARKING ADJACENT TO THE SYMBOL.

CE SYMBOLE INDIQUE QUE LE FUSIBLE UTILISE EST LENT. POUR UNE PROTECTION PERMANENTE, N'UTILISER QUE DES FUSIBLES DE MEME TYPE. CE DERNIER EST INDIQUE LA QU LE PRESENT SYMBOLE EST APPOSE.

NOTE

- THE COMPONENTS IDENTIFIED BY MARK ARE CRITICAL FOR SAFETY. REPLACE ONLY WITH PART NUMBER SPECIFIED.
- VOLTAGE (MEASURED WITH) IS DC VOLTAGE. (NO INPUT SIGNAL)
- ELECTROLYTIC CAPACITORS () ARE IN uF/WV.
- ALL CAPACITORS ARE IN pF/50V UNLESS OTHERWISE NOTED.
EX) 030-3pF 330-33pF 331 330pF 333-0.033uF
- ALL RESISTORS ARE IN OHMS 1/4WATTS UNLESS OTHERWISE NOTED.
- THE THICK LINES ON PC BOARD ARE THE PRINTING SIDE OF THE PARTS.
EX) PRINTING SIDE
- CIRCUIT IS SUBJECT TO CHANGE FOR IMPROVEMENT.

A

B

C

D

SCHEMATIC DIAGRAM - 3

<MUP> model only

U7 : SCART TERMINAL PC BOARD NAETC-7614

1

2

3

4

5

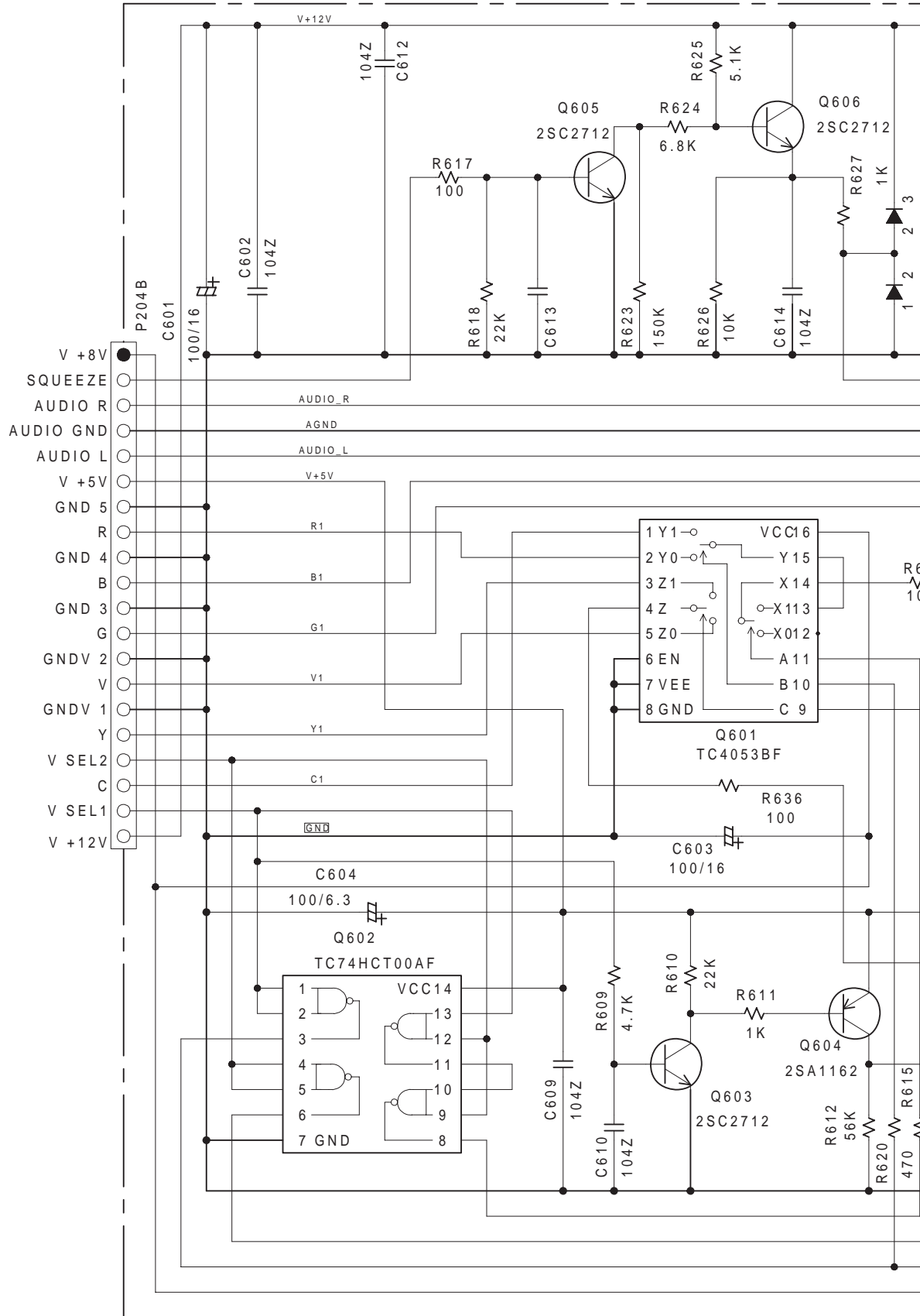

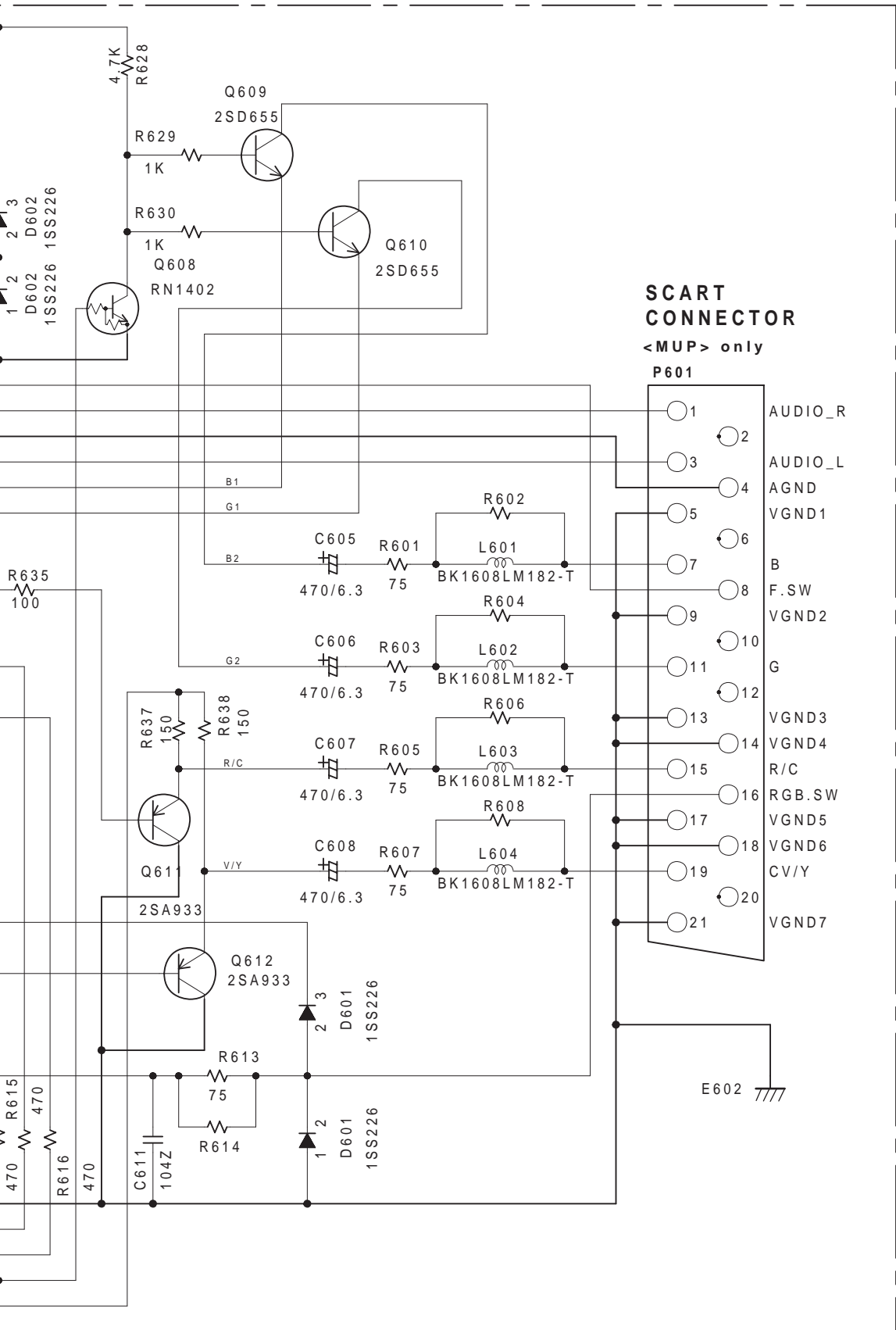

A B C D E F G H

SCHEMATIC DIAGRAM - 3
<MUP> model only

U7: SCART TERMINAL PC BOARD NAETC-7614

1
2
3
4
5

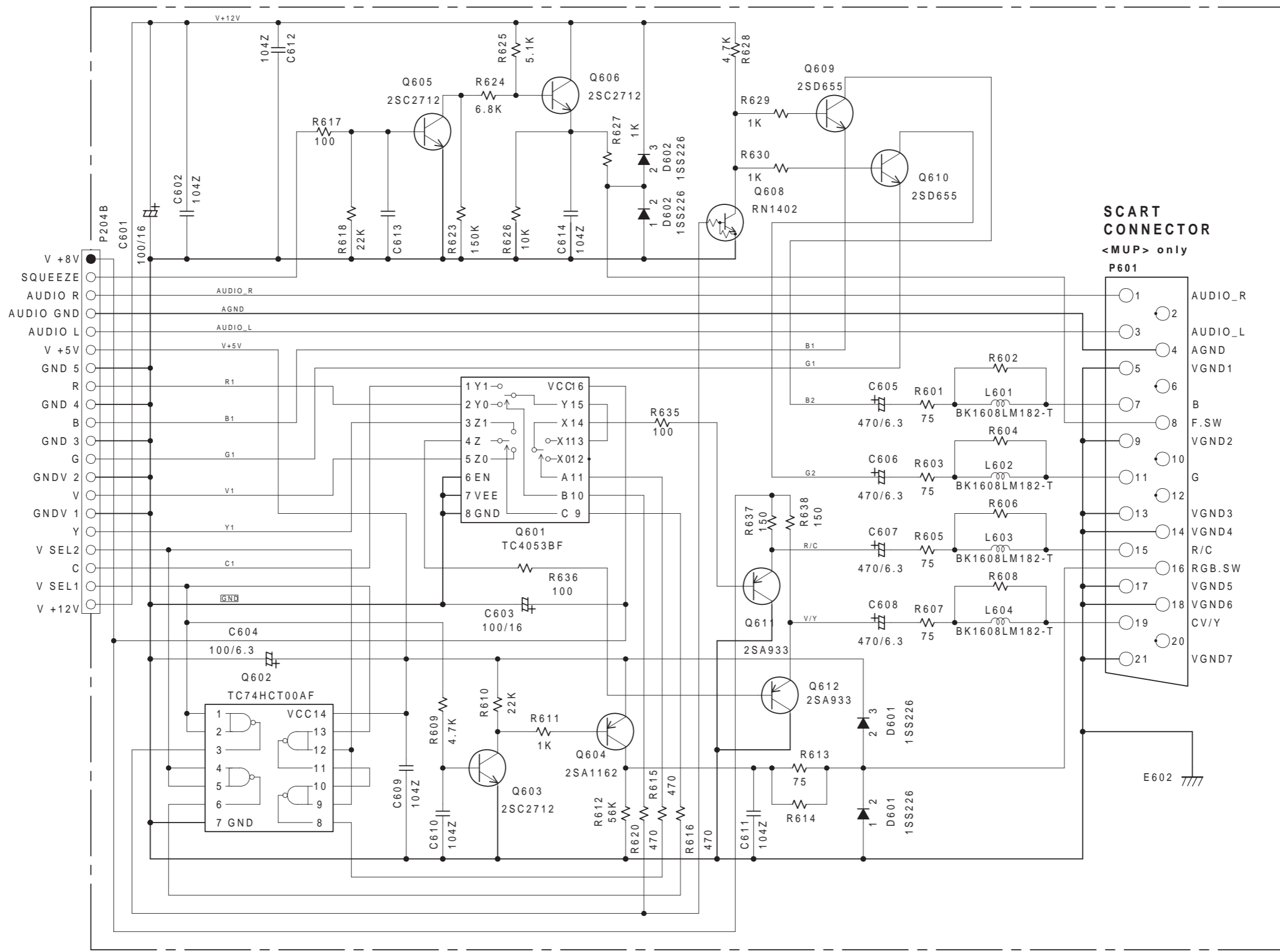

SCHEMATIC DIAGRAM

Power supply unit

24150020A NGPS-0020 <MDD>
 24150021A NGPS-0021 <MUP/MUT/MUS>

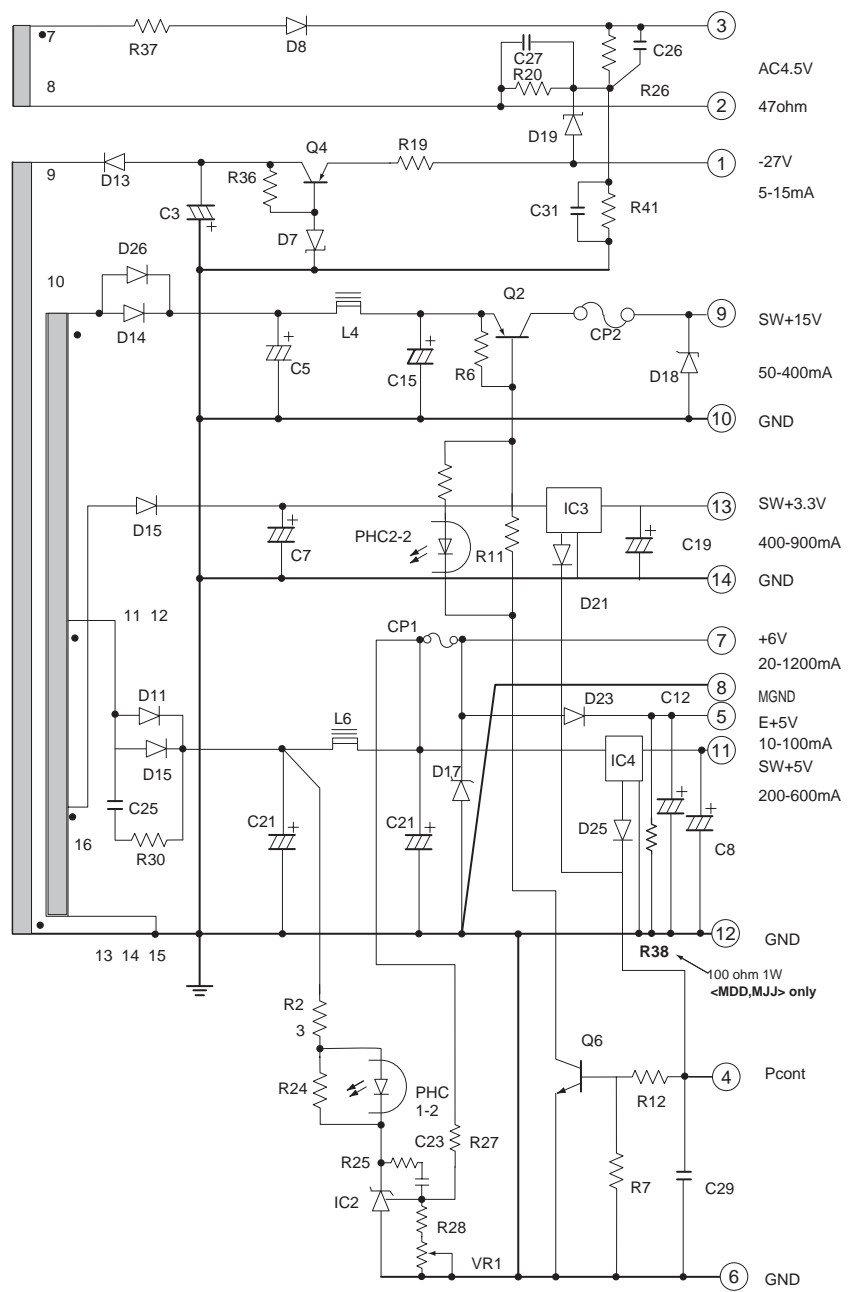
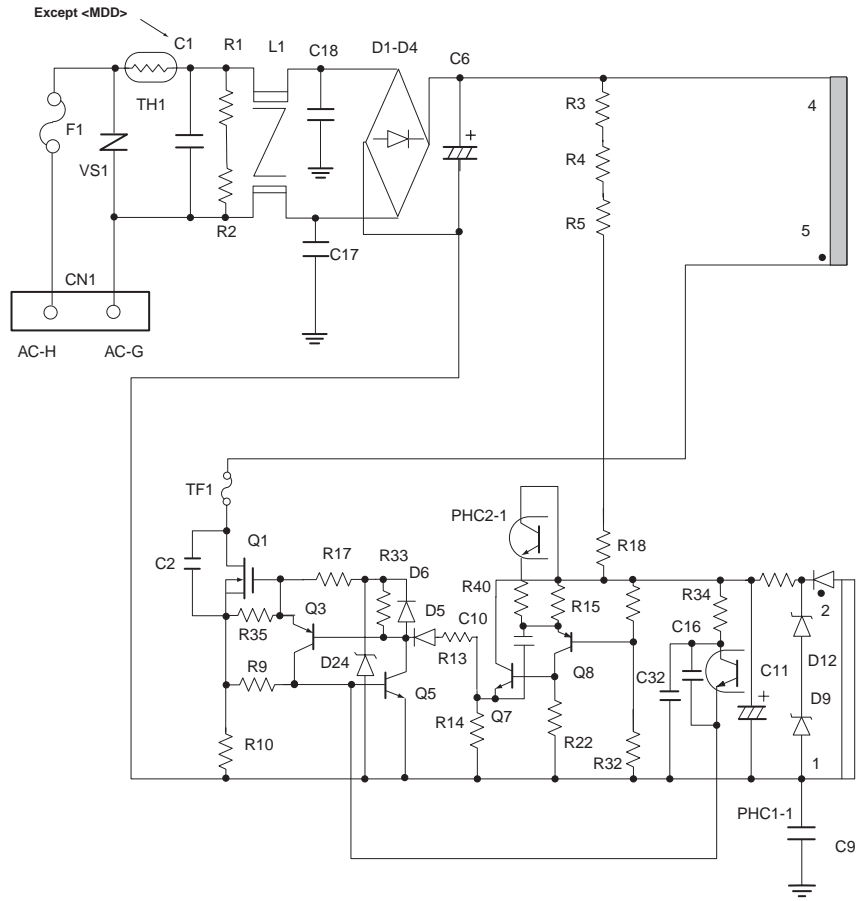

SCHEMATIC DIAGRAM (Page 1)

Z100 :Main circuit PC board (DB-VPB306/301)

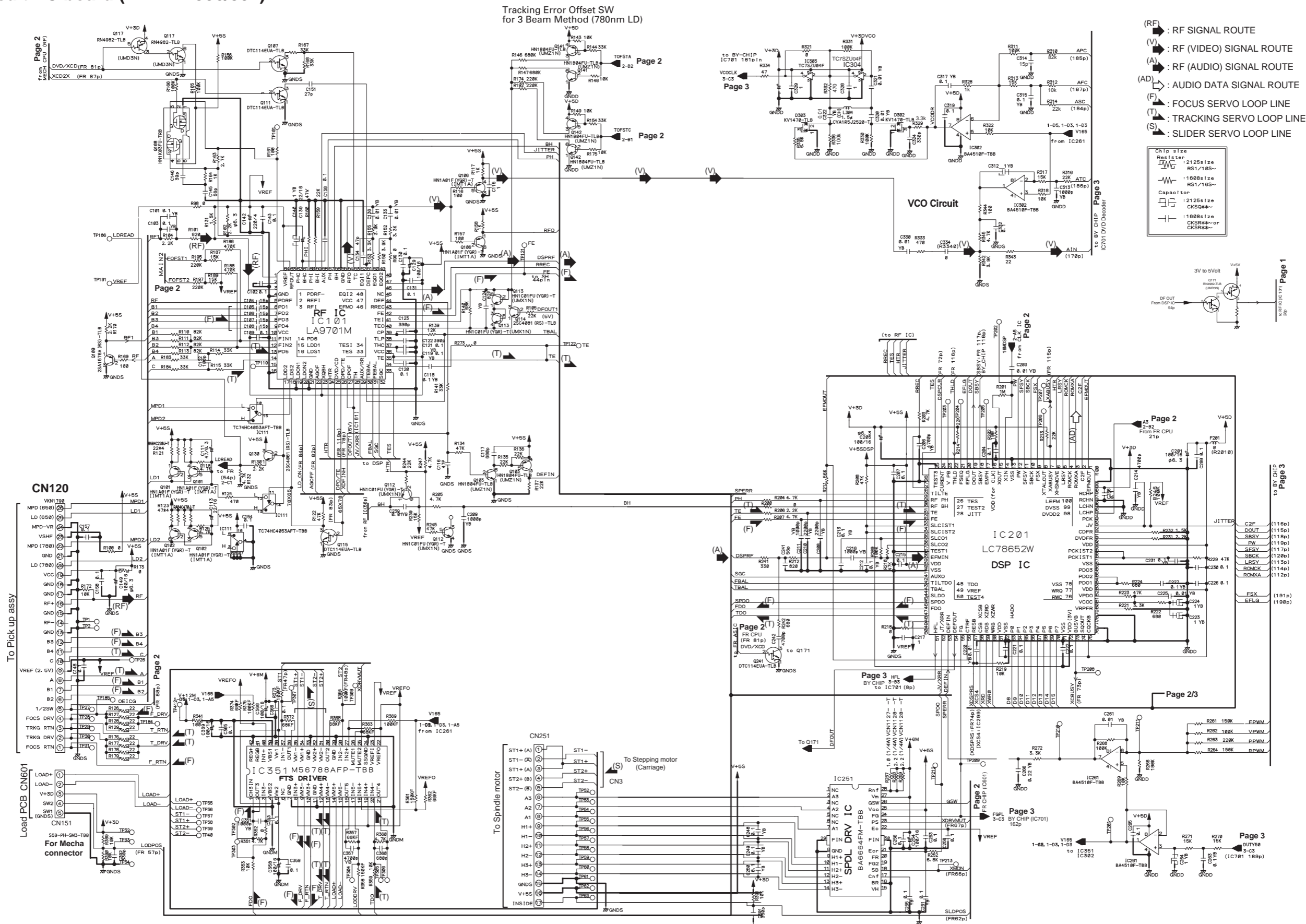

A

B

C

D

To Pick up assy

To Stepping motor (Carriage) CN3

To Spindle motor CN251

Load PCB CN601 For Mecha connector

1

2

3

4

SCHEMATIC DIAGRAM (Page 1)

Z100 :Main circuit PC board (DB-VPB306/301)

Tracking Error Offset SW for 3 Beam Method (780nm LD)

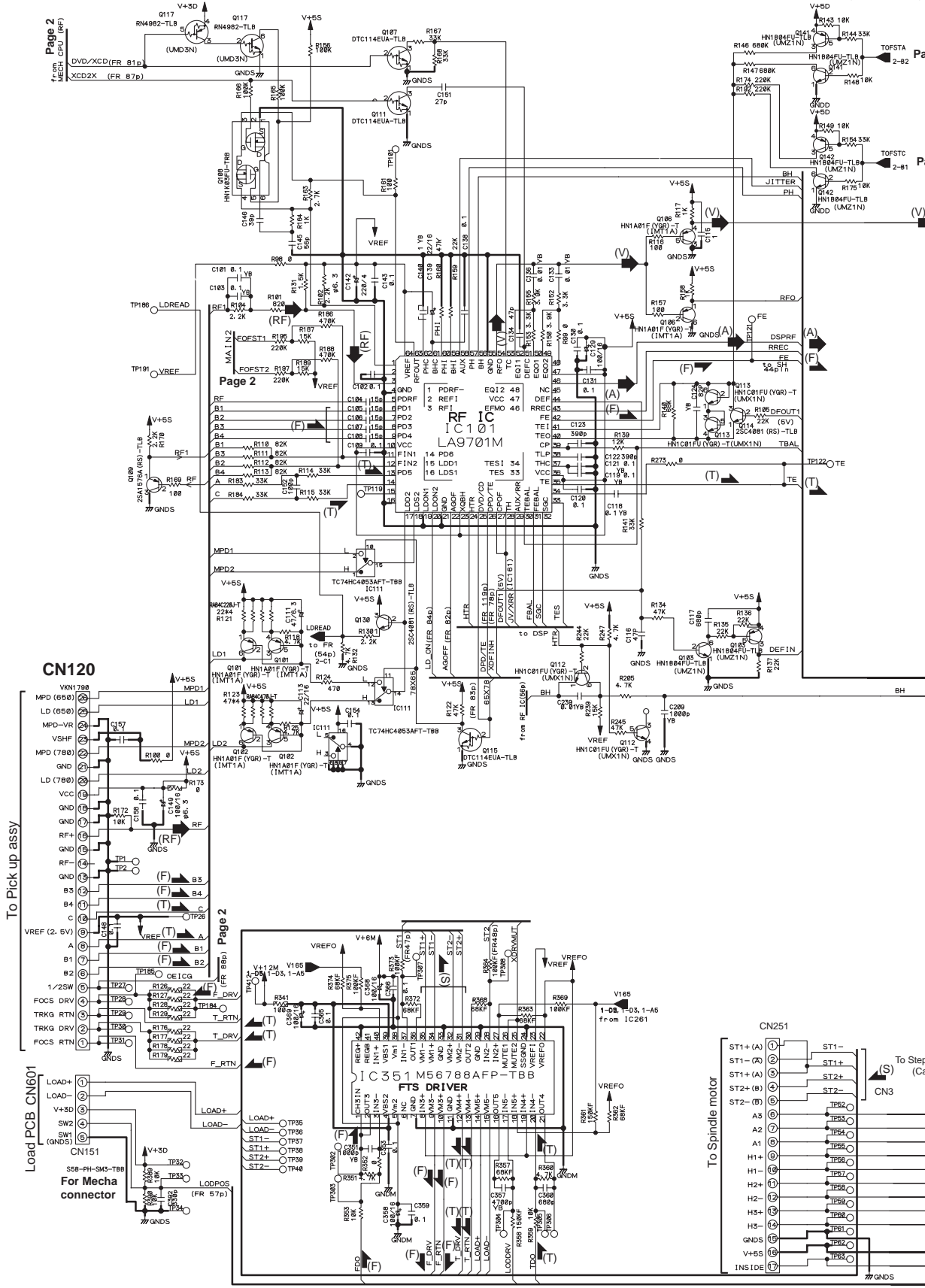

A

B

C

D

To Pick up assy

Load PCB CN601

To Spindle motor

For Mecha connector

To Stepp (Car)

D)

Page 2

Page 2



- (RF) : RF SIGNAL ROUTE
- (V) : RF (VIDEO) SIGNAL ROUTE
- (A) : RF (AUDIO) SIGNAL ROUTE
- (AD) : AUDIO DATA SIGNAL ROUTE
- (F) : FOCUS SERVO LOOP LINE
- (T) : TRACKING SERVO LOOP LINE
- (S) : SLIDER SERVO LOOP LINE

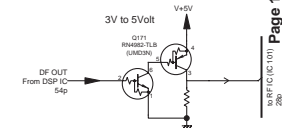
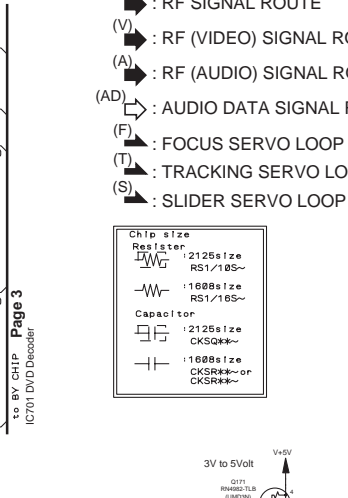
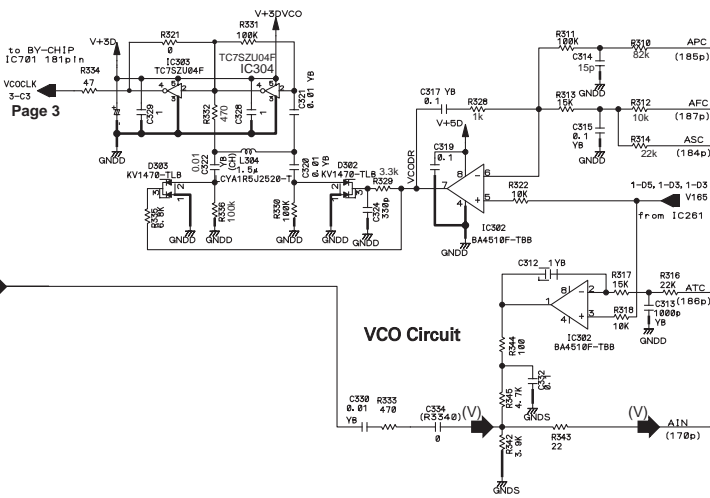
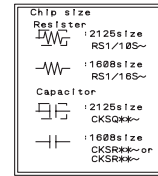

Page 1

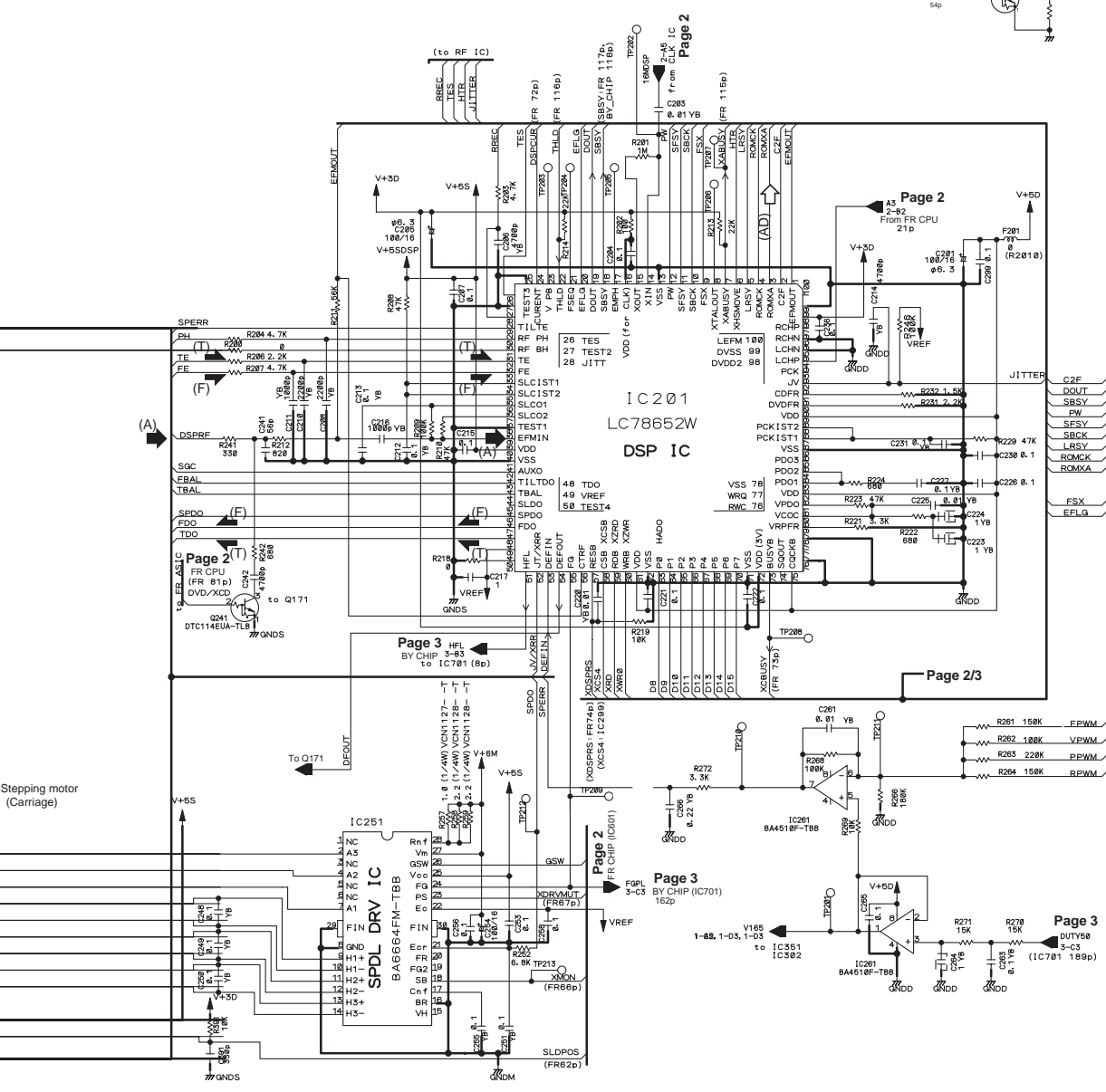

Page 3

Stepping motor (Carriage)

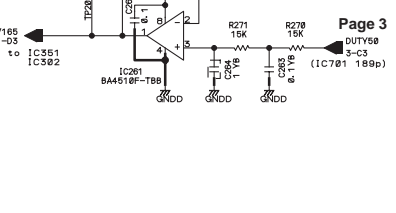
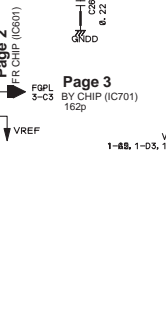
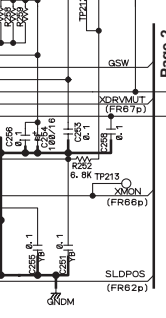
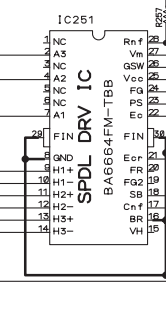
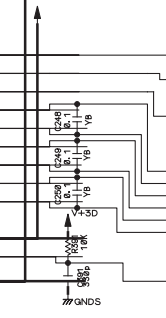

SCHEMATIC DIAGRAM (Page 2)
Z100 :Main circuit PC board (DB-VPB306/301)

A
B
C
D

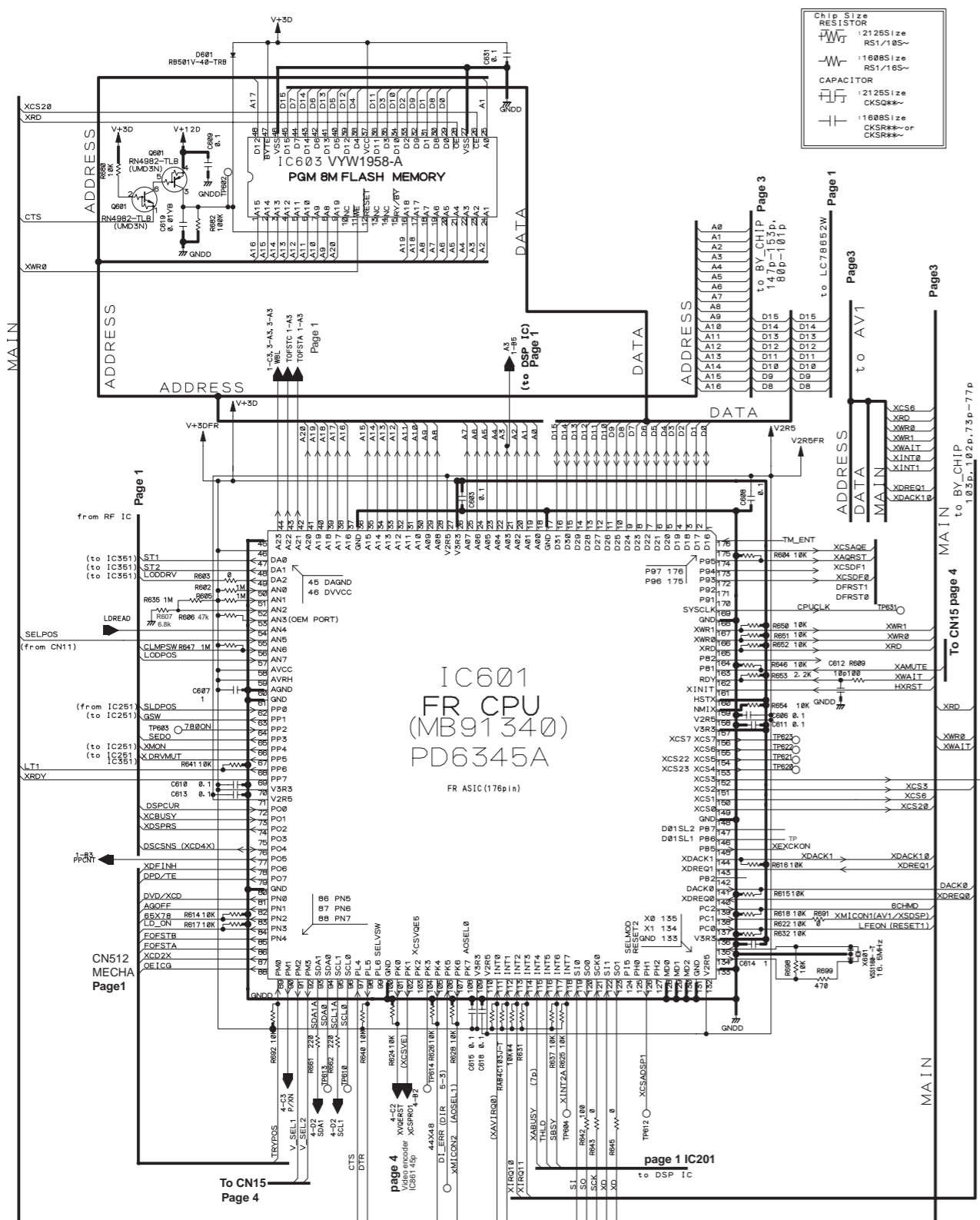

Chip Size
RESISTOR
CAPACITOR

- 2125S size RS1/10S
- 1008S size RS1/10S
- 2125S size CKSR** or CKSR**~
- 1008S size CKSR** or CKSR**~

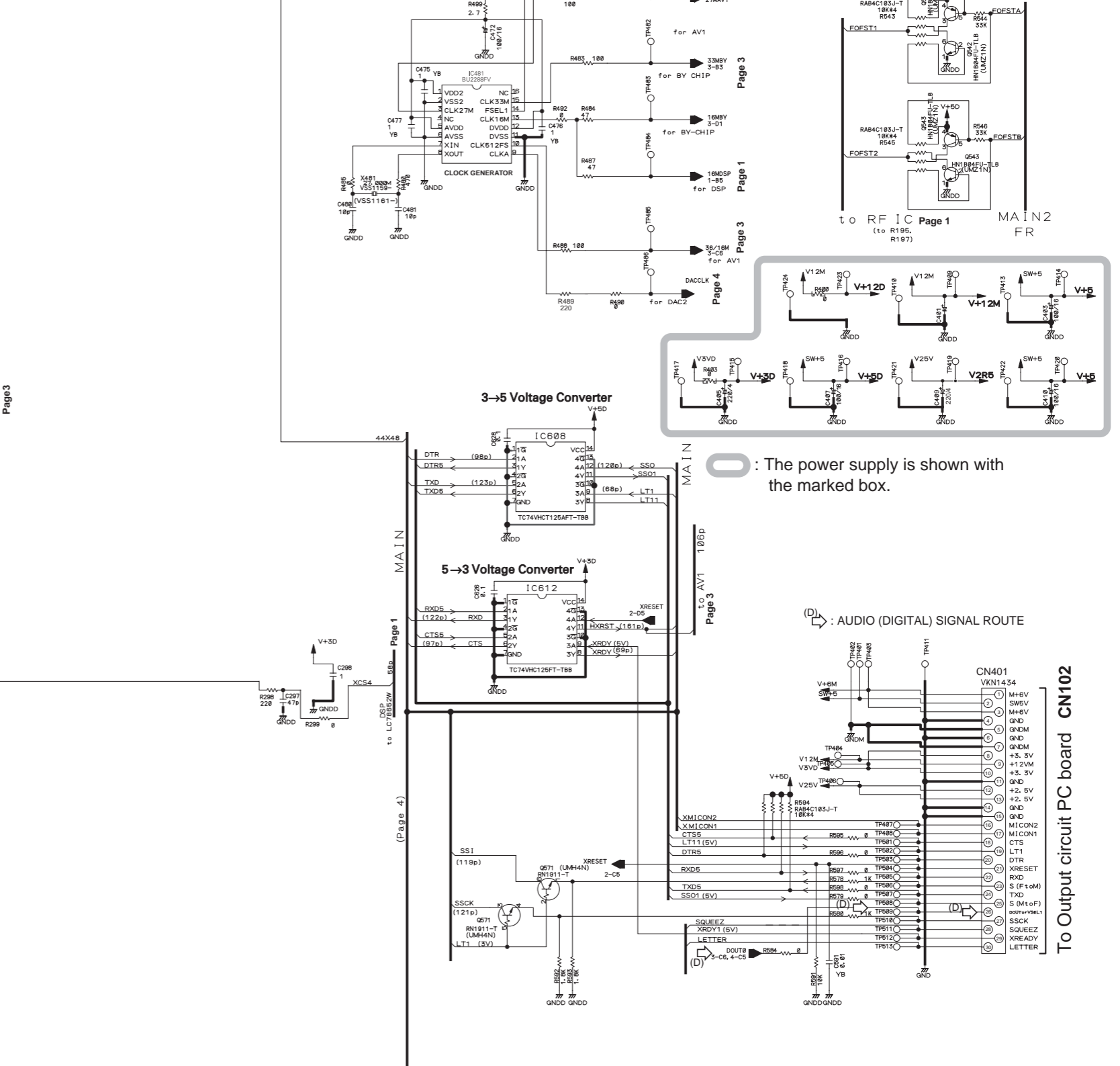

The power supply is shown with the marked box.

AUDIO (DIGITAL) SIGNAL ROUTE

To Output circuit PC board CN102

SCHEMATIC DIAGRAM (Page 2) Z100 :Main circuit PC board (DB-VPB306/301)

A

B

C

D

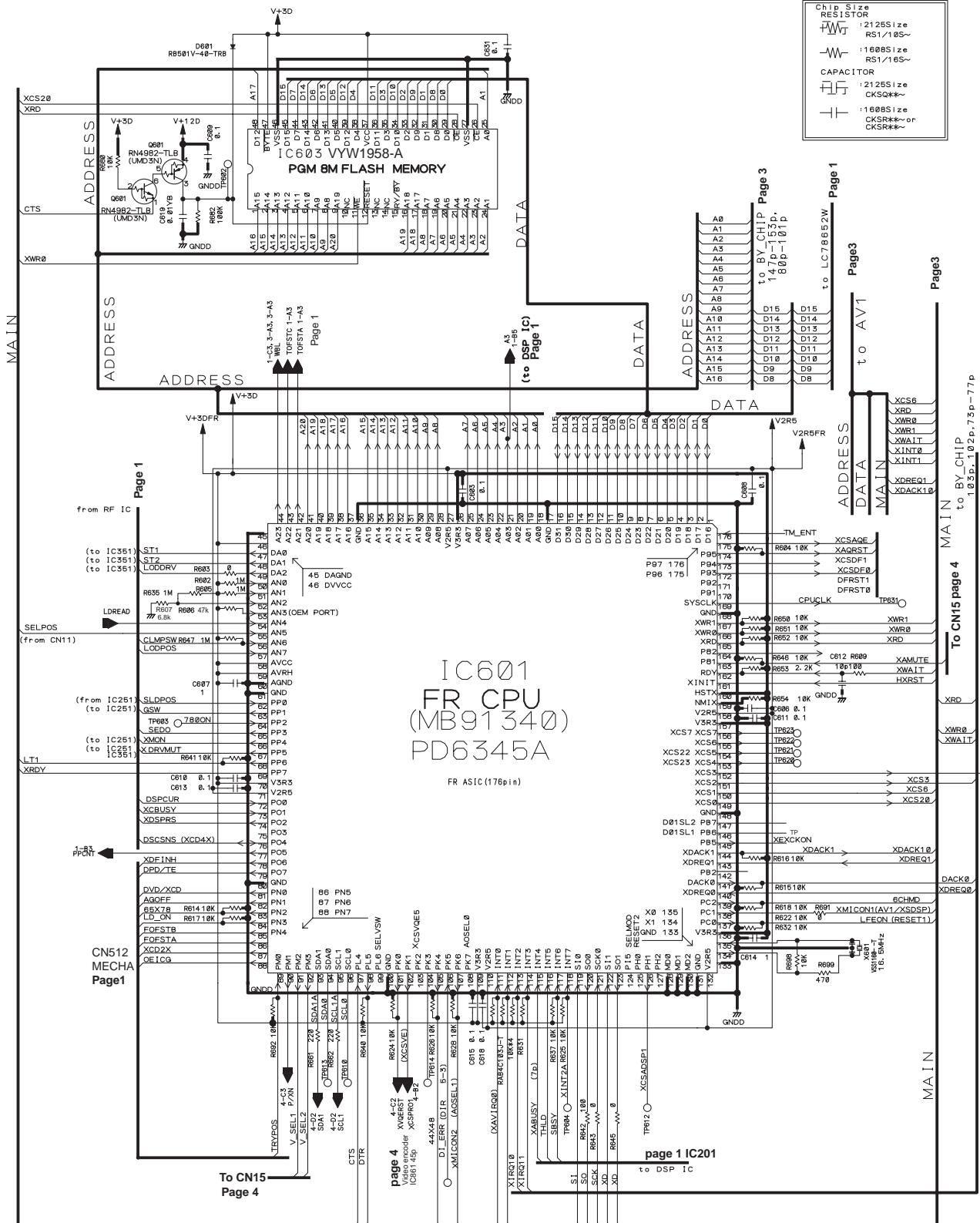

Chip Size	: 2125Size
RESISTOR	FWJ
	: R51/10S~
	: R51/16S~
CAPACITOR	FW
	: C125Size
	: CKS0***~
	: C160Size
	: CKSR***~ or
	: CKSR***~

IC601
FR CPU
(MB91340)
PD6345A
FR ASIC(178pin)

page 1 IC201
to DSP IC

To CN15
Page 4

To CN15 page 4
to BY CHIP
1.83p, 1.02p, 7.5p-77p

Page3
to AV1

Page 1
to LCT8852W

to BY CHIP Page 3
147p-153p,
80p-101p

MAIN

MAIN

MAIN

MAIN

MAIN

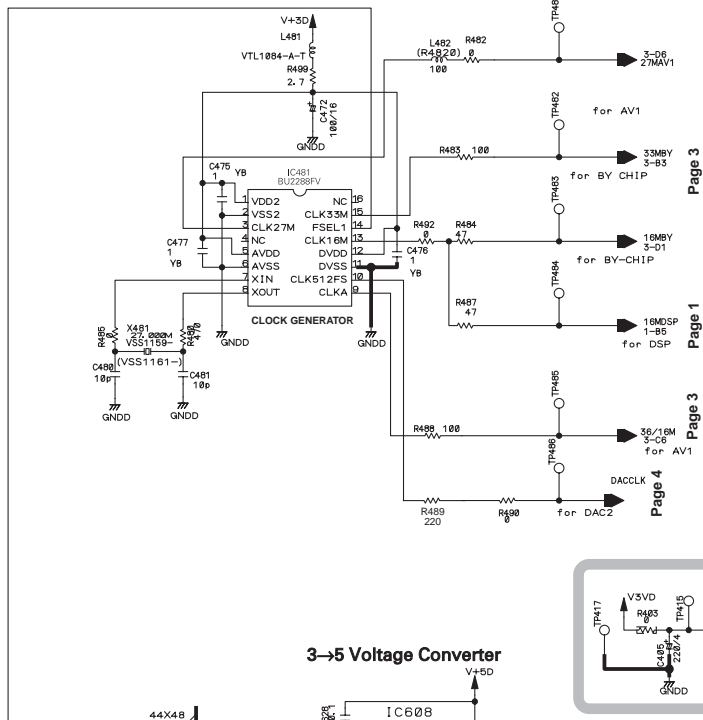

Page 3

Page 1

Page 3

Page 4

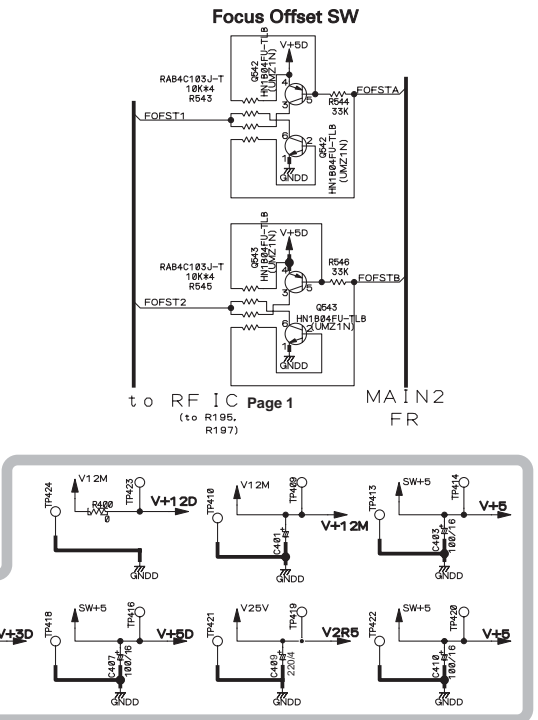

Focus Offset SW

t to RF IC Page 1 MAIN 2 FR

3→5 Voltage Converter

5→3 Voltage Converter

: The power supply is shown with the marked box.

: AUDIO (DIGITAL) SIGNAL ROUTE

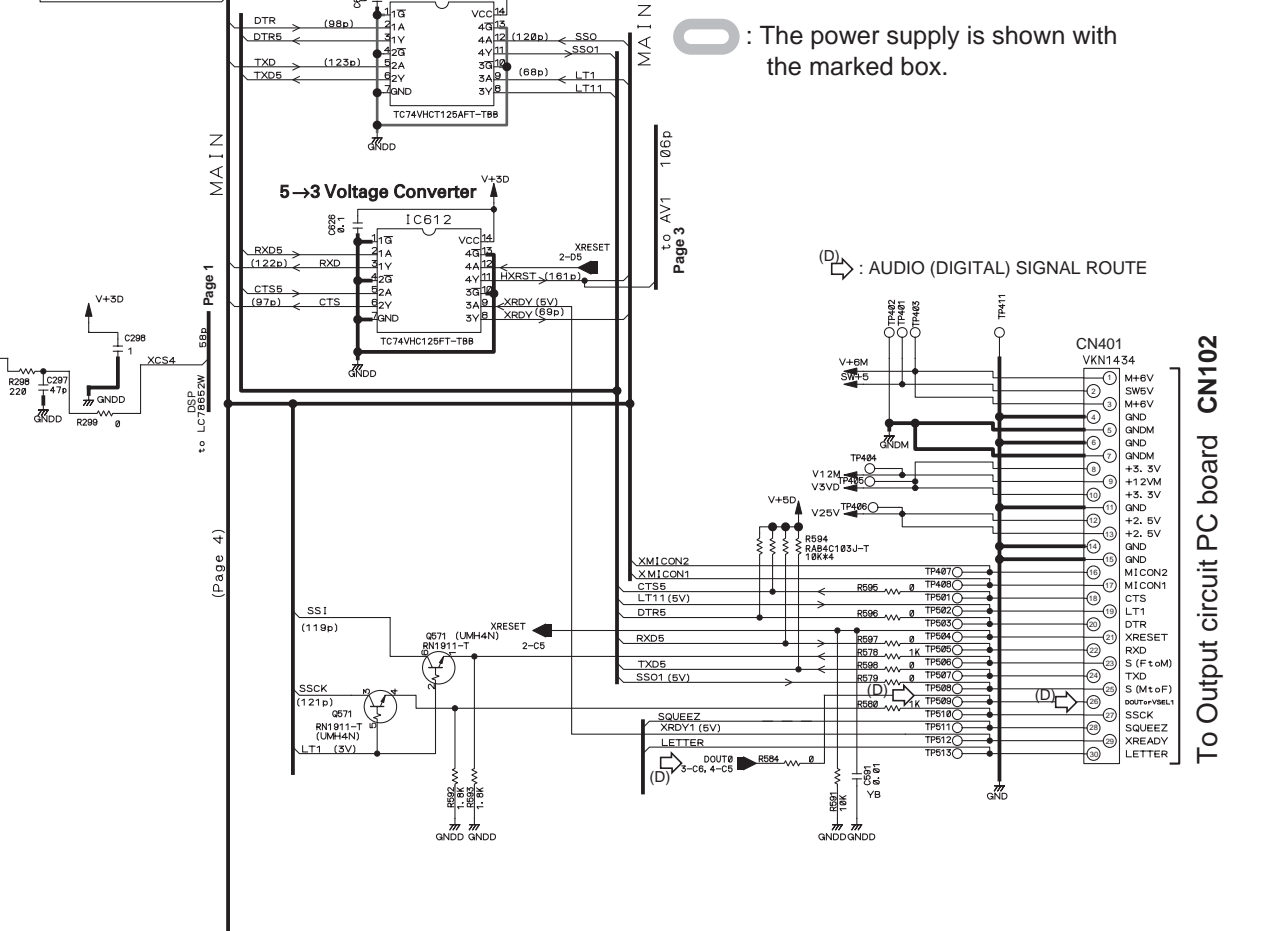

To Output circuit PC board CN102

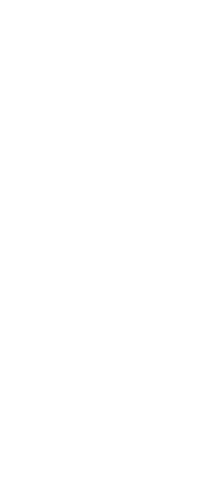

SCHEMATIC DIAGRAM (Page 3)
Z100 :Main circuit PC board (DB-VPB306/301)

A

B

C

D

1 2 3 4 5 6 7 8

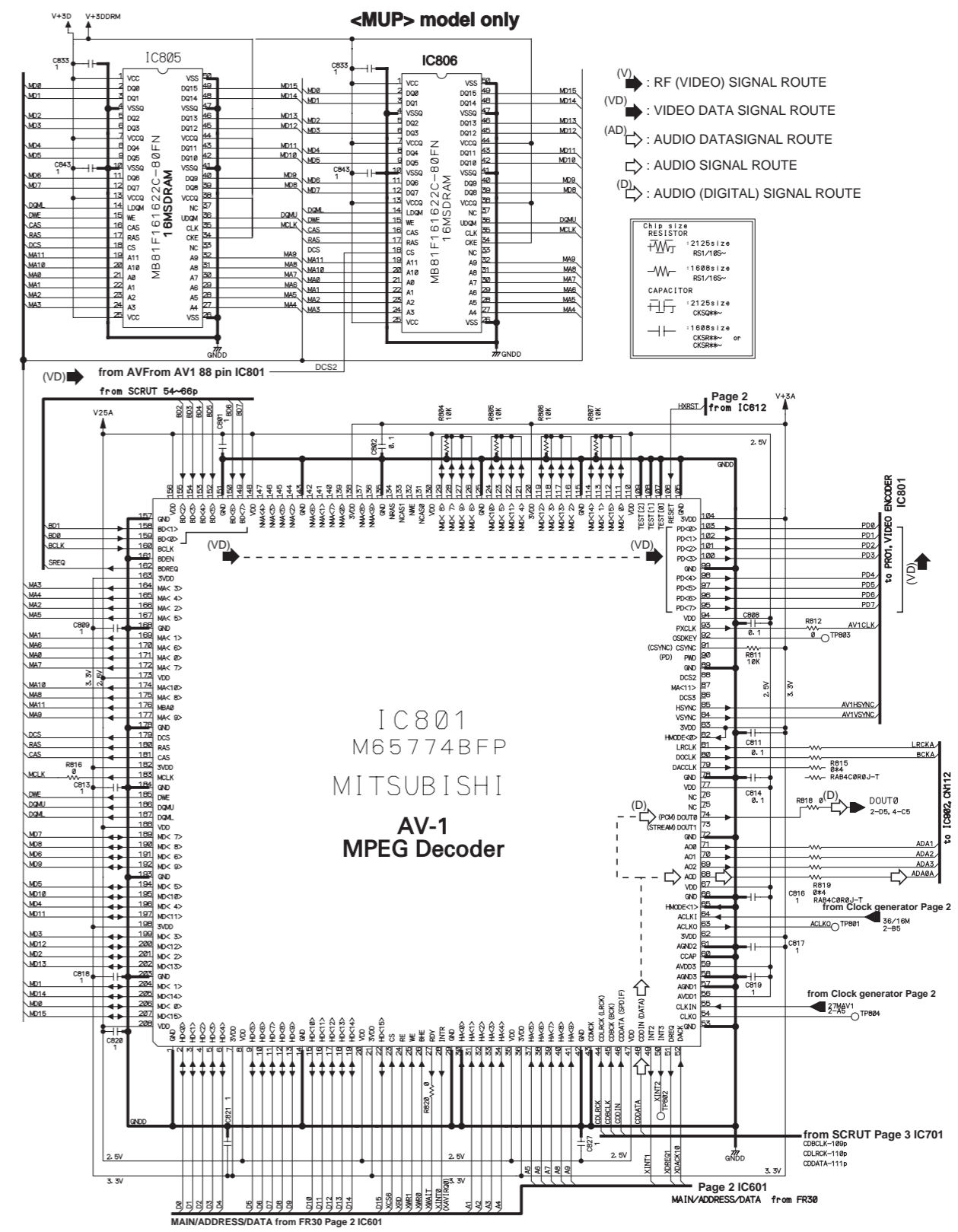
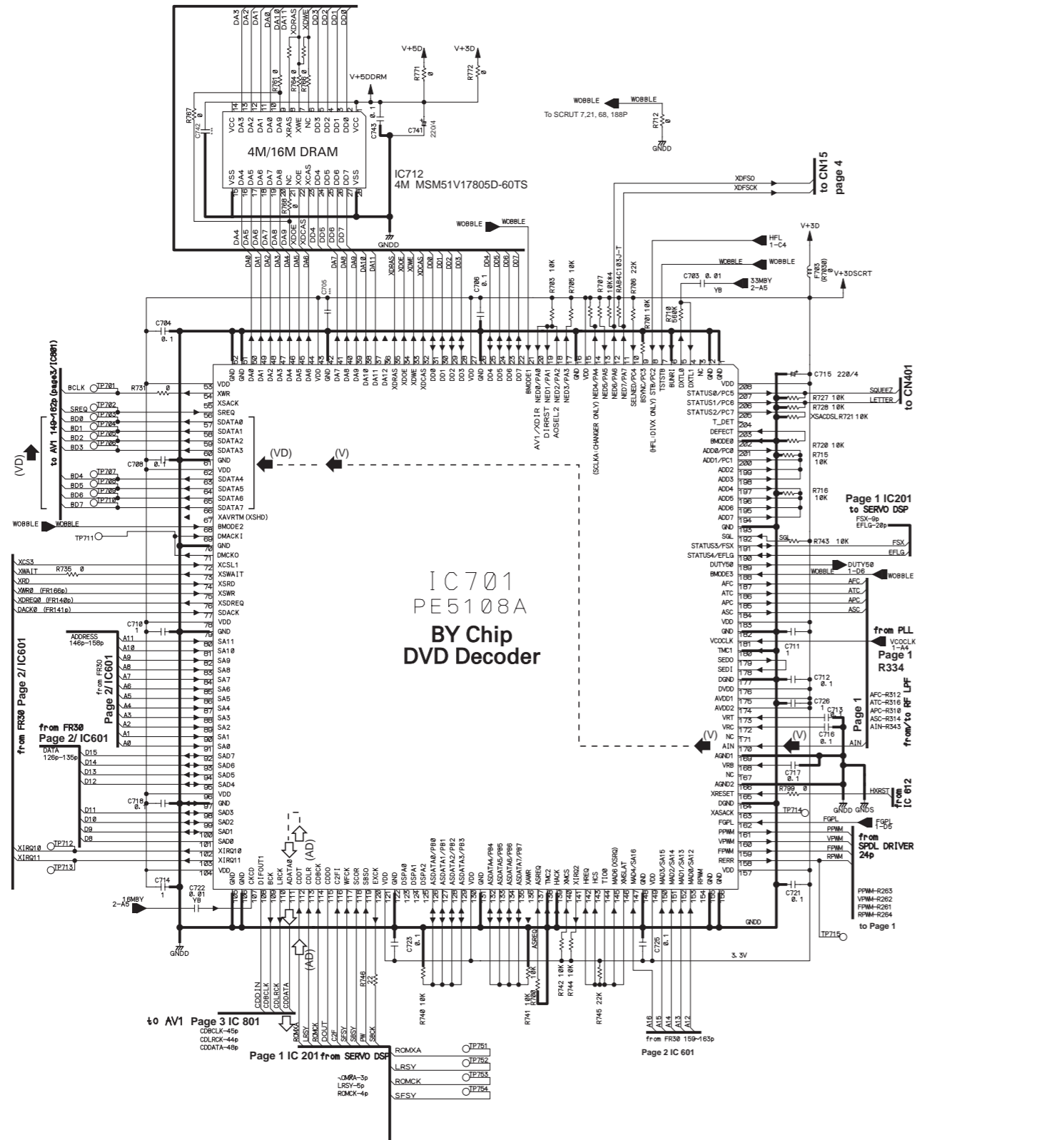

- (V) : RF (VIDEO) SIGNAL ROUTE
- (VD) : VIDEO DATA SIGNAL ROUTE
- (AD) : AUDIO DATASIGNAL ROUTE
- : AUDIO SIGNAL ROUTE
- (D) : AUDIO (DIGITAL) SIGNAL ROUTE

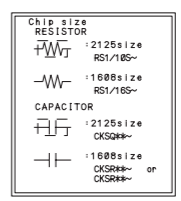

MAIN/ADDRESS/DATA from FR30 Page 2 IC601

Page 2 IC601
MAIN/ADDRESS/DATA from FR30

SCHEMATIC DIAGRAM (Page 3)

Z100 :Main circuit PC board (DB-VPB306/301)

A

B

C

D

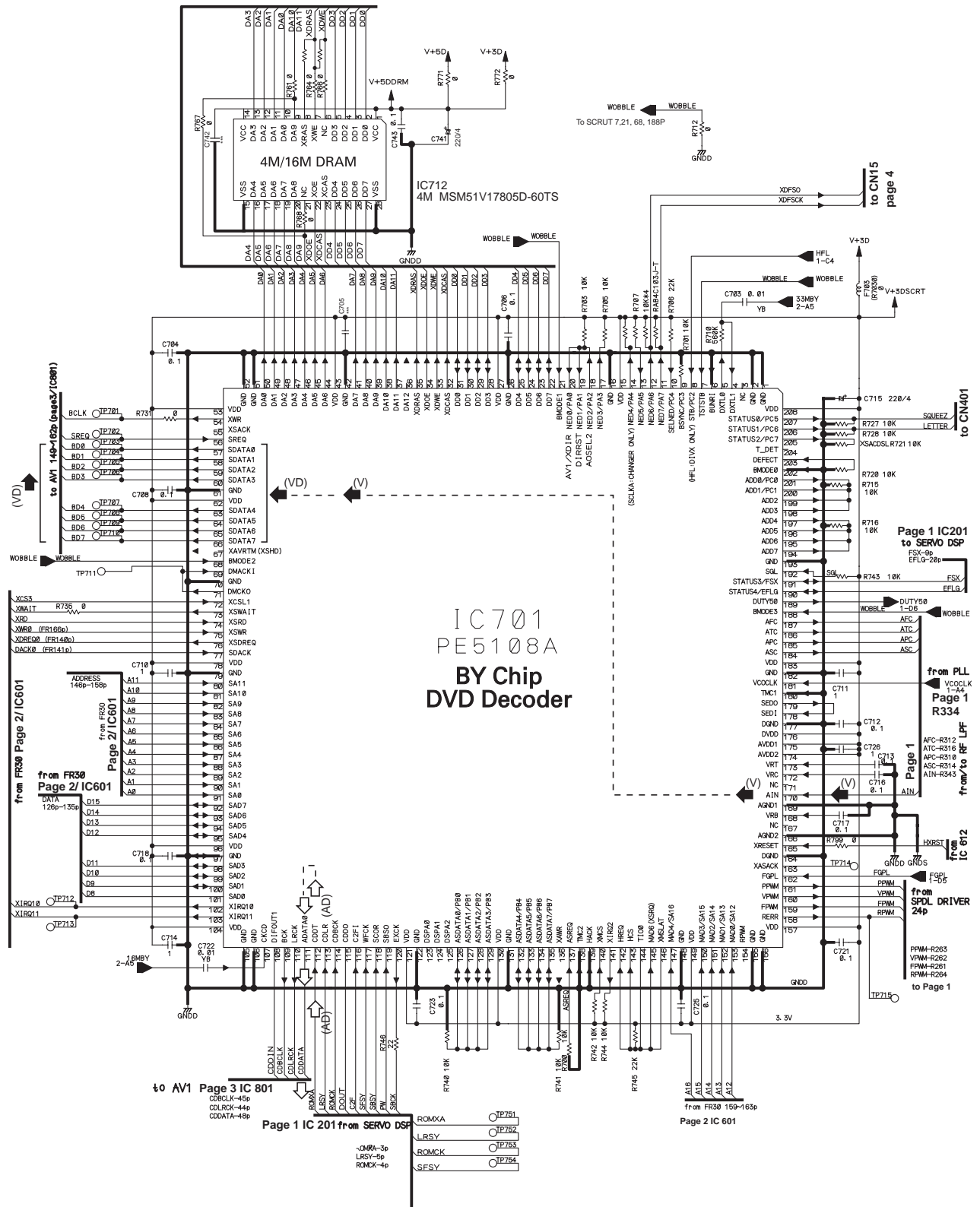

SCHEMATIC DIAGRAM (Page 4)

Z100 :Main circuit PC board (DB-VPB306/301)

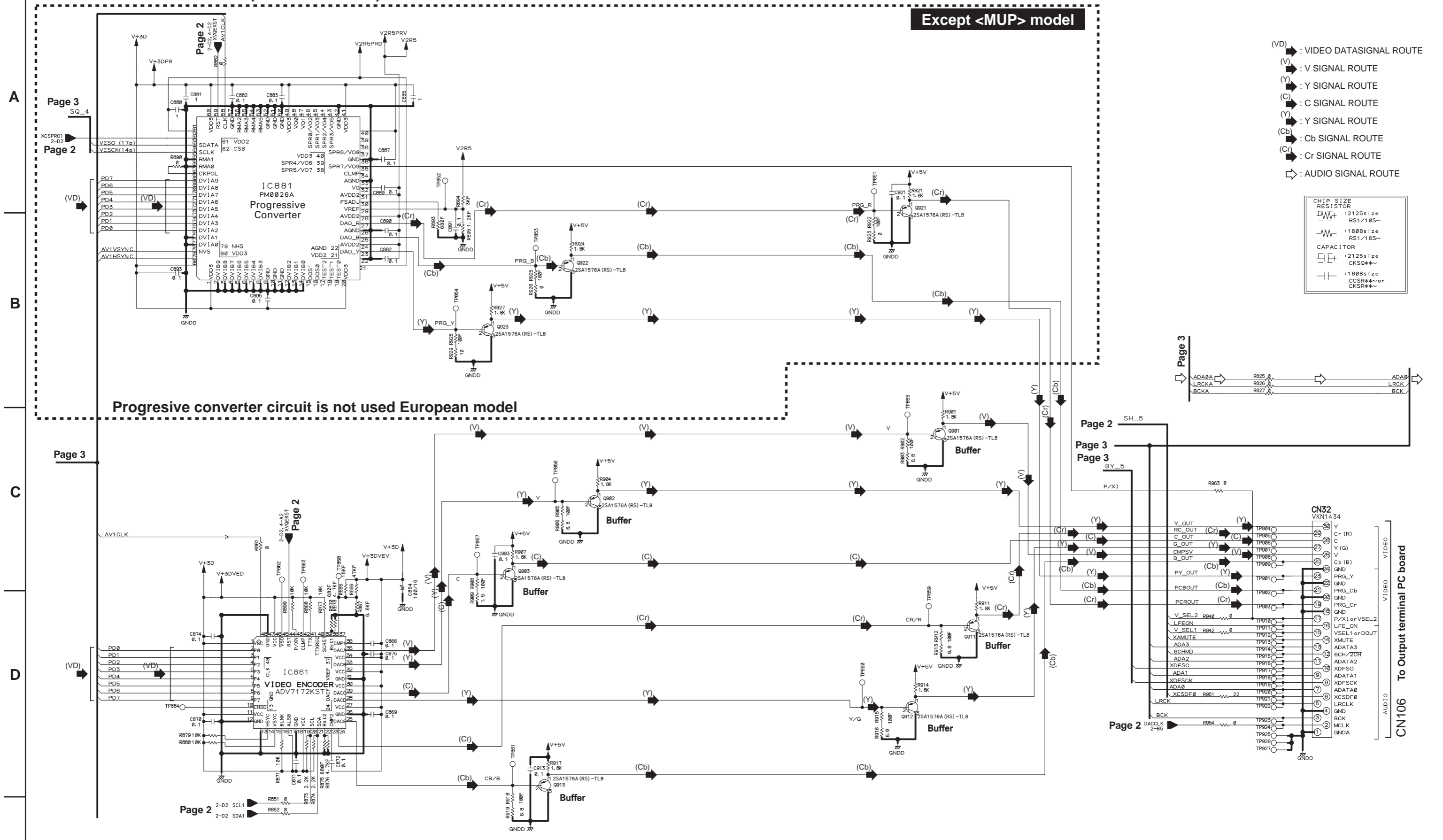

Except <MUP> model

- (VD) : VIDEO DATASIGNAL ROUTE
- (V) : V SIGNAL ROUTE
- (Y) : Y SIGNAL ROUTE
- (C) : C SIGNAL ROUTE
- (Y) : Y SIGNAL ROUTE
- (Cb) : Cb SIGNAL ROUTE
- (Cr) : Cr SIGNAL ROUTE
- (A) : AUDIO SIGNAL ROUTE

CHIP SIZE	
	: 2125size RS1/16S~
	: 1608size RS1/16S~
	: 2125size CKSQ**~
	: 1608size CCSR** or CKSR**~

Progressive converter circuit is not used European model

To Output terminal PC board

1

2

3

4

SCHEMATIC DIAGRAM (Page 4)

Z100 :Main circuit PC board (DB-VPB306/301)

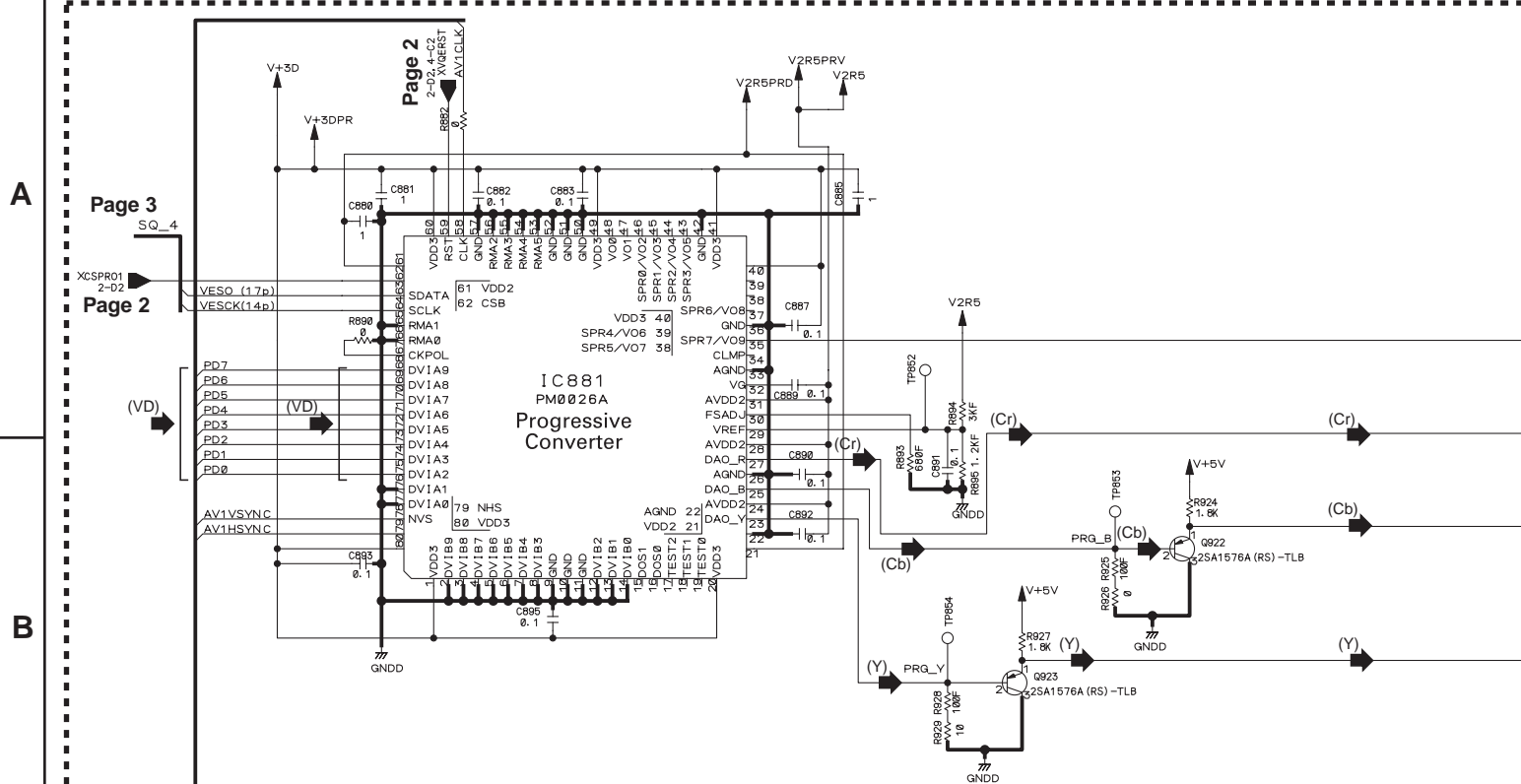

Progressive converter circuit is not used European model

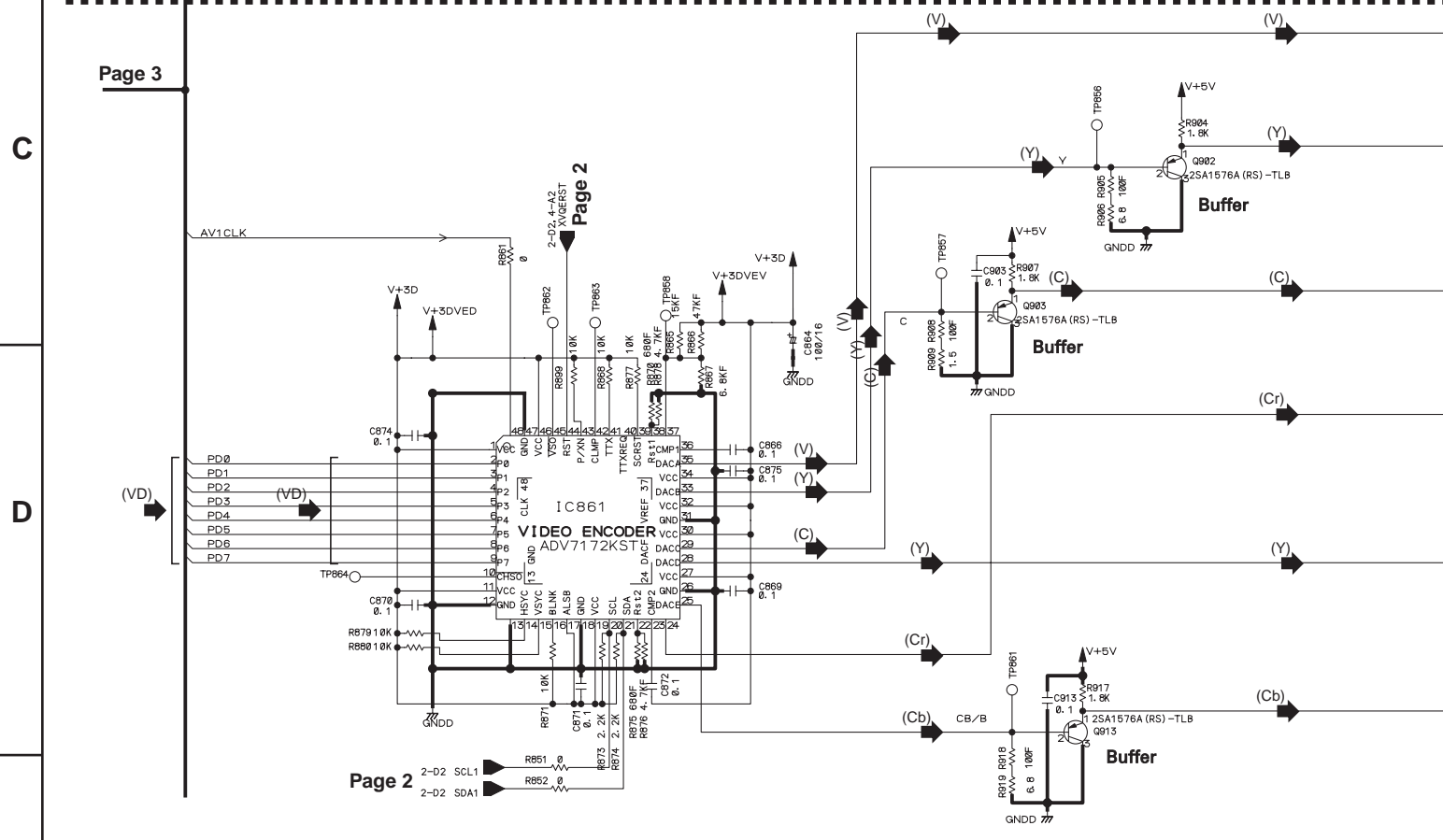

Progressive converter circuit is not used European model

Except <MUP> model

- (VD) : VIDEO DATASIGNAL ROUTE
- (V) : V SIGNAL ROUTE
- (Y) : Y SIGNAL ROUTE
- (C) : C SIGNAL ROUTE
- (Y) : Y SIGNAL ROUTE
- (Cb) : Cb SIGNAL ROUTE
- (Cr) : Cr SIGNAL ROUTE
- ⇨ : AUDIO SIGNAL ROUTE

CHIP SIZE RESISTOR	
	: 2125size RS1/10S~
	: 1608size RS1/16S~
CAPACITOR	
	: 2125size CKSQ**~
	: 1608size CCSR** or CKSR**~

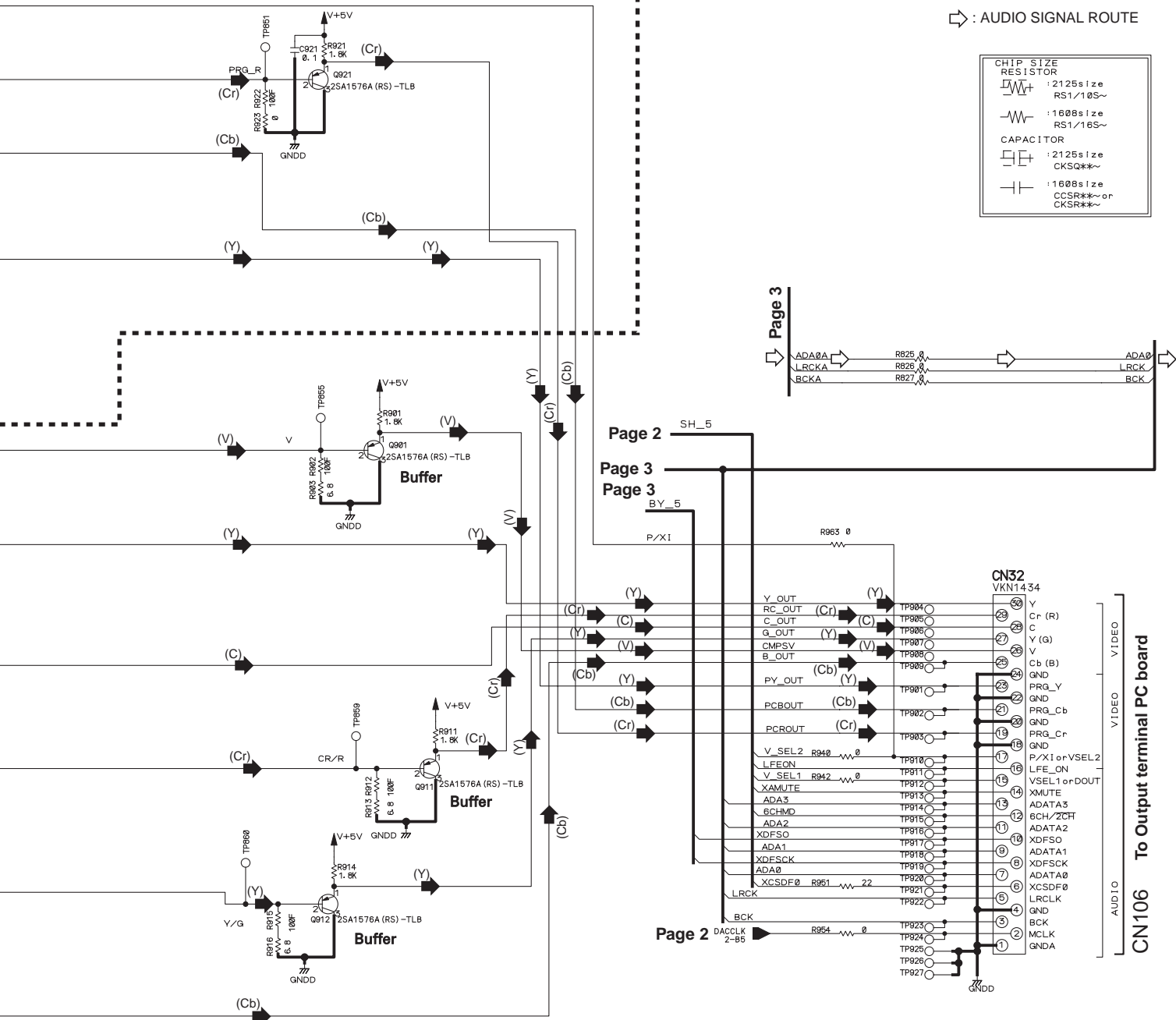

PC BOARD CONNECTION DIAGRAM

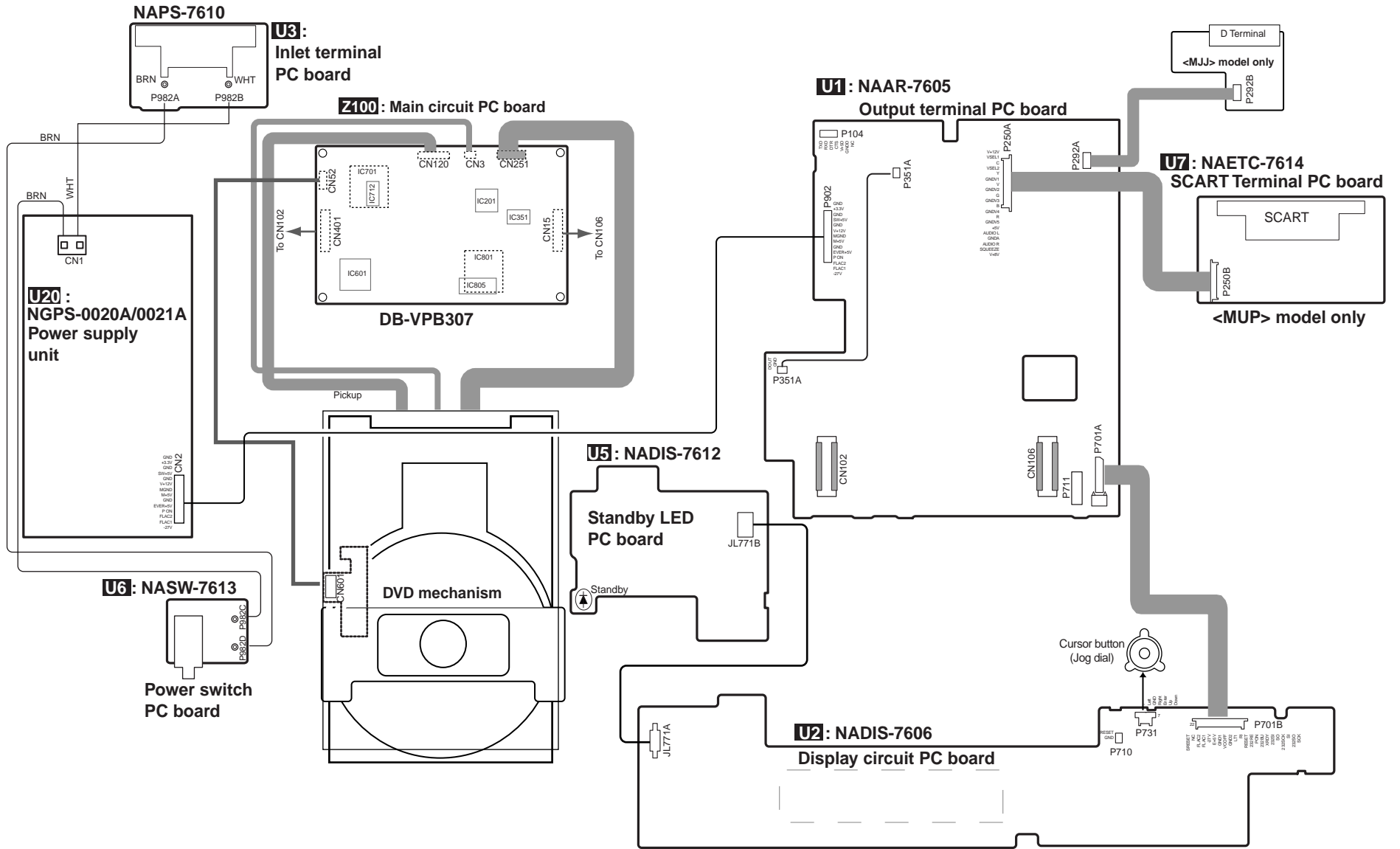

A

B

C

D

PRINTED CIRCUIT BOARD VIEW

Except <MUP> model

Z100: Main circuit PC board DB-VPB306

1

2

3

4

5

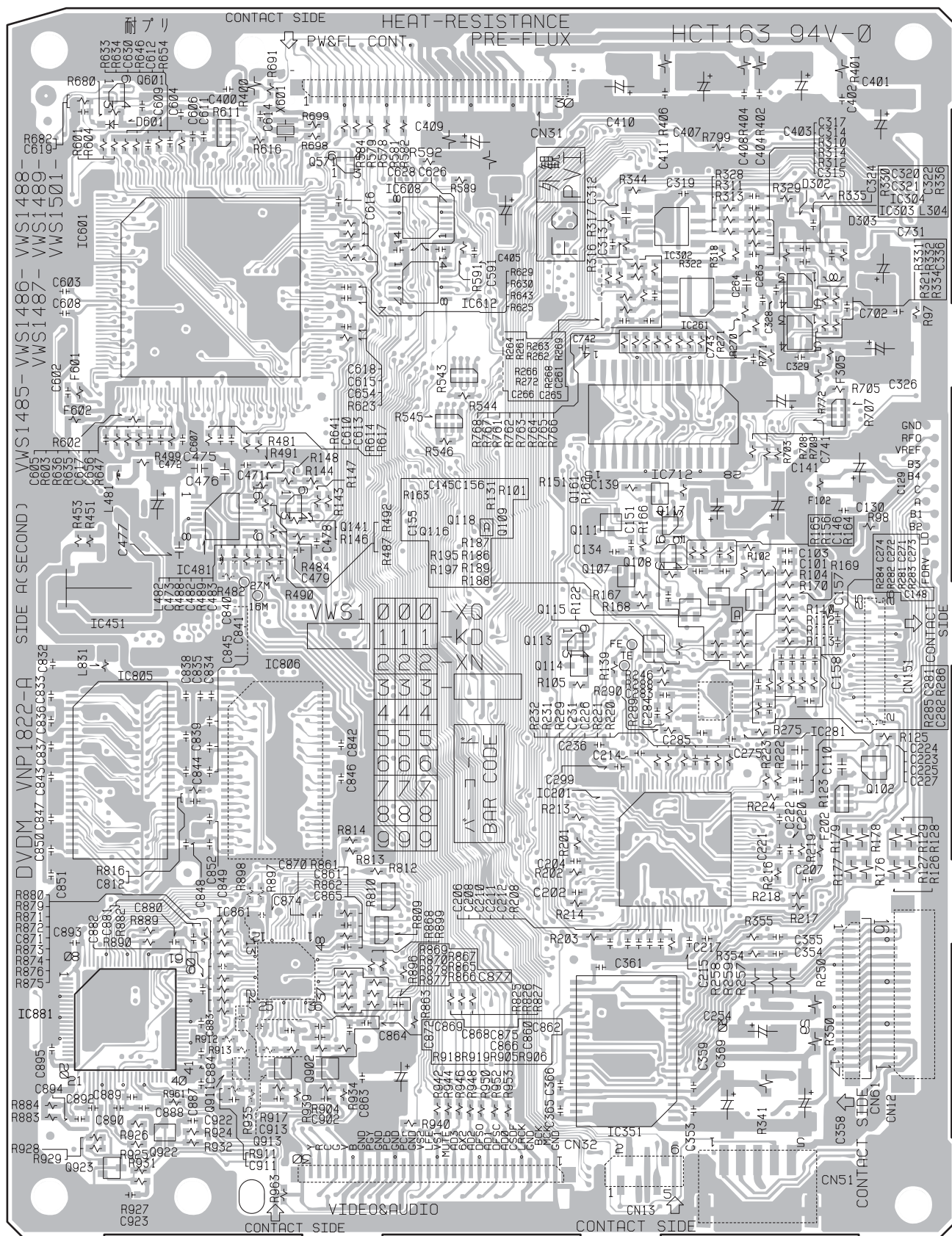

SIDE A

A

B

C

D

PRINTED CIRCUIT BOARD VIEW

Except <MUP> model

Z100: Main circuit PC board DB-VPB306

1

2

3

4

5

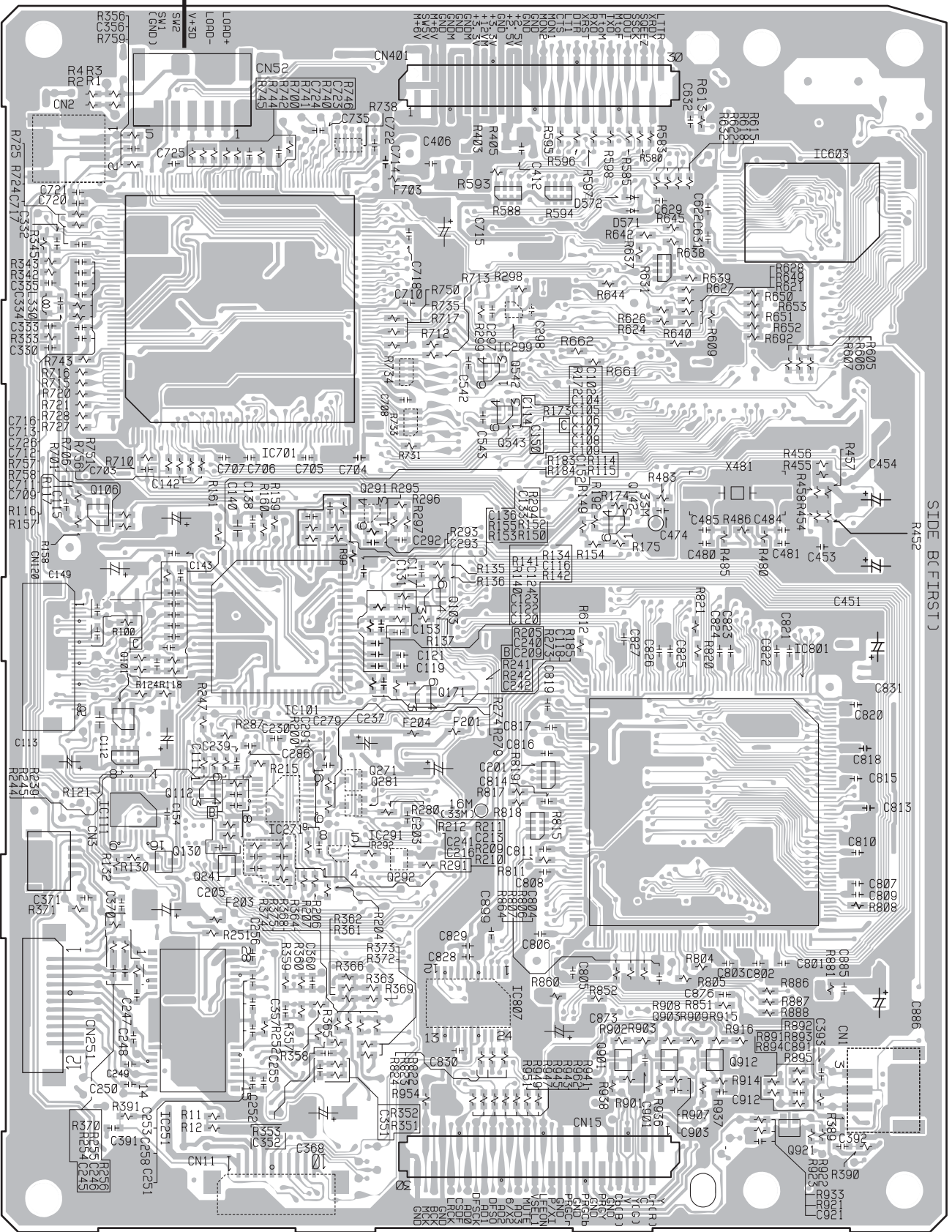

SIDE B (FIRST)

SIDE B

A

B

C

D

PRINTED CIRCUIT BOARD VIEW <MUP> model only

Z101 : MAIN CIRCUIT PC BOARD DB-VPB301

1

2

3

4

5

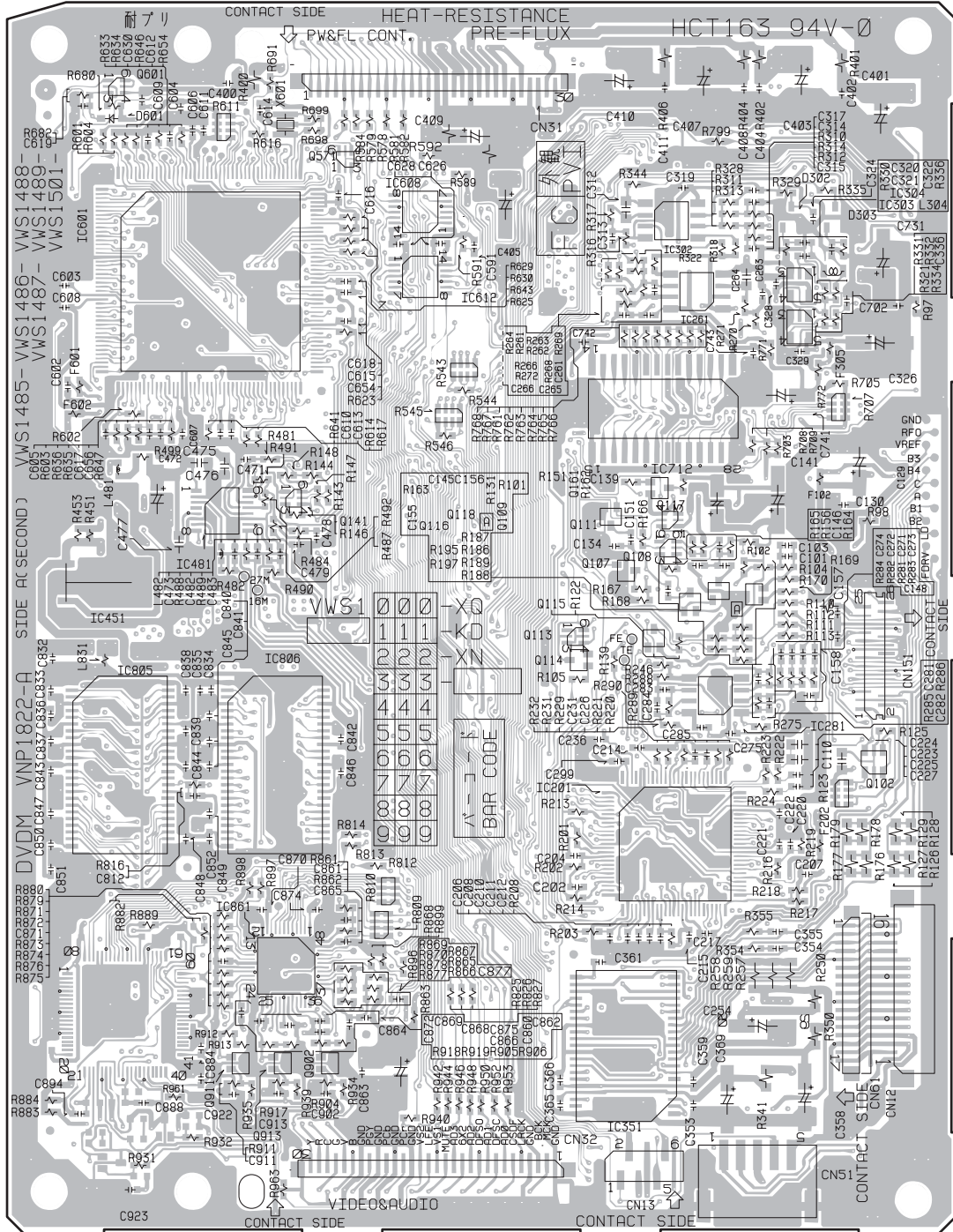

Bottom pattern and bottom silk

A

B

C

D

PRINTED CIRCUIT BOARD VIEW <MUP> model only

Z101 : MAIN CIRCUIT PC BOARD DB-VPB301

1

2

3

4

5

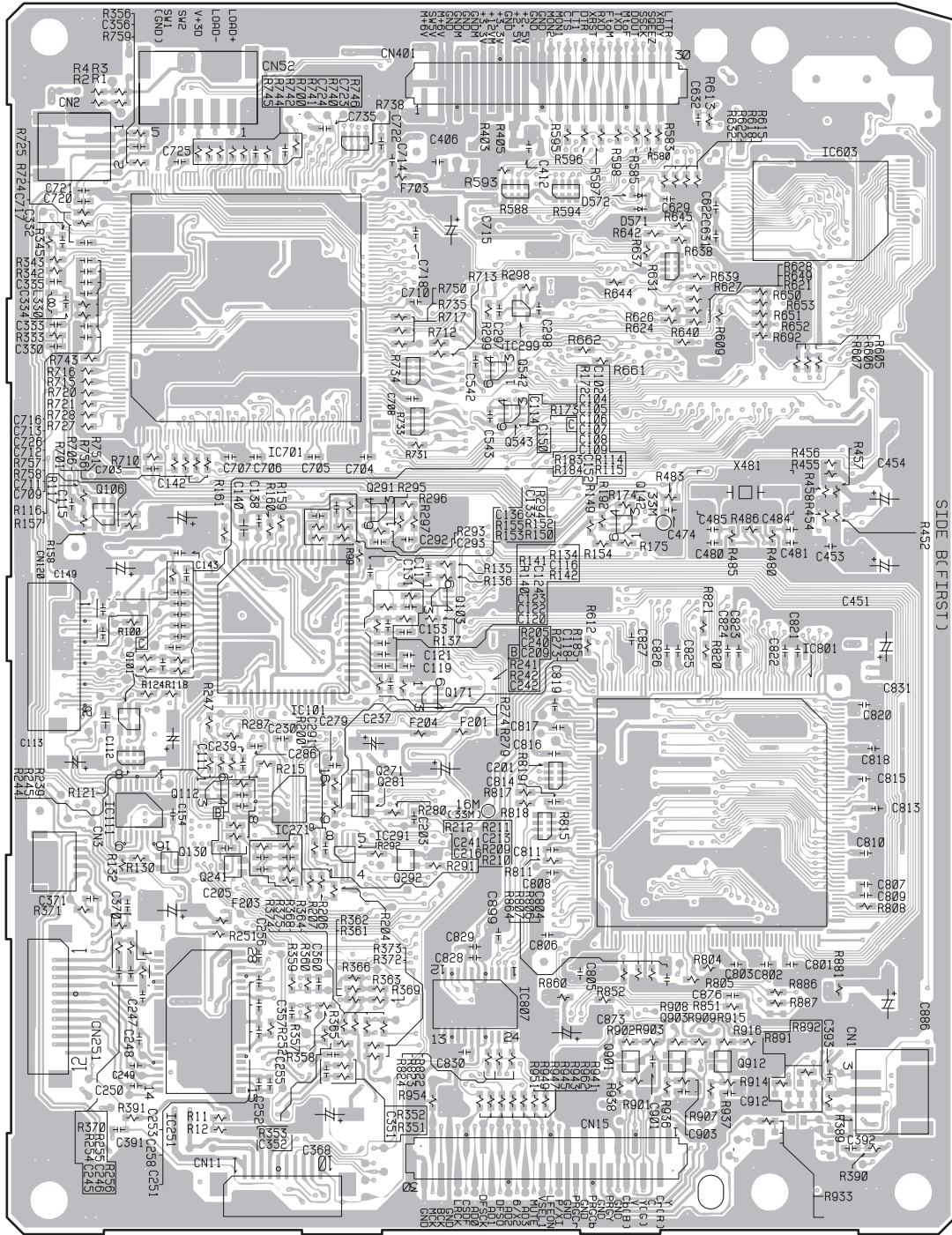

Top pattern and top silk

A

B

C

D

PRINTED CIRCUIT BOARD VIEW FROM SOLDERING SIDE-1

1

U1: OUTPUT TERMINAL PC BOARD (NAAR-7605)

2

3

4

5

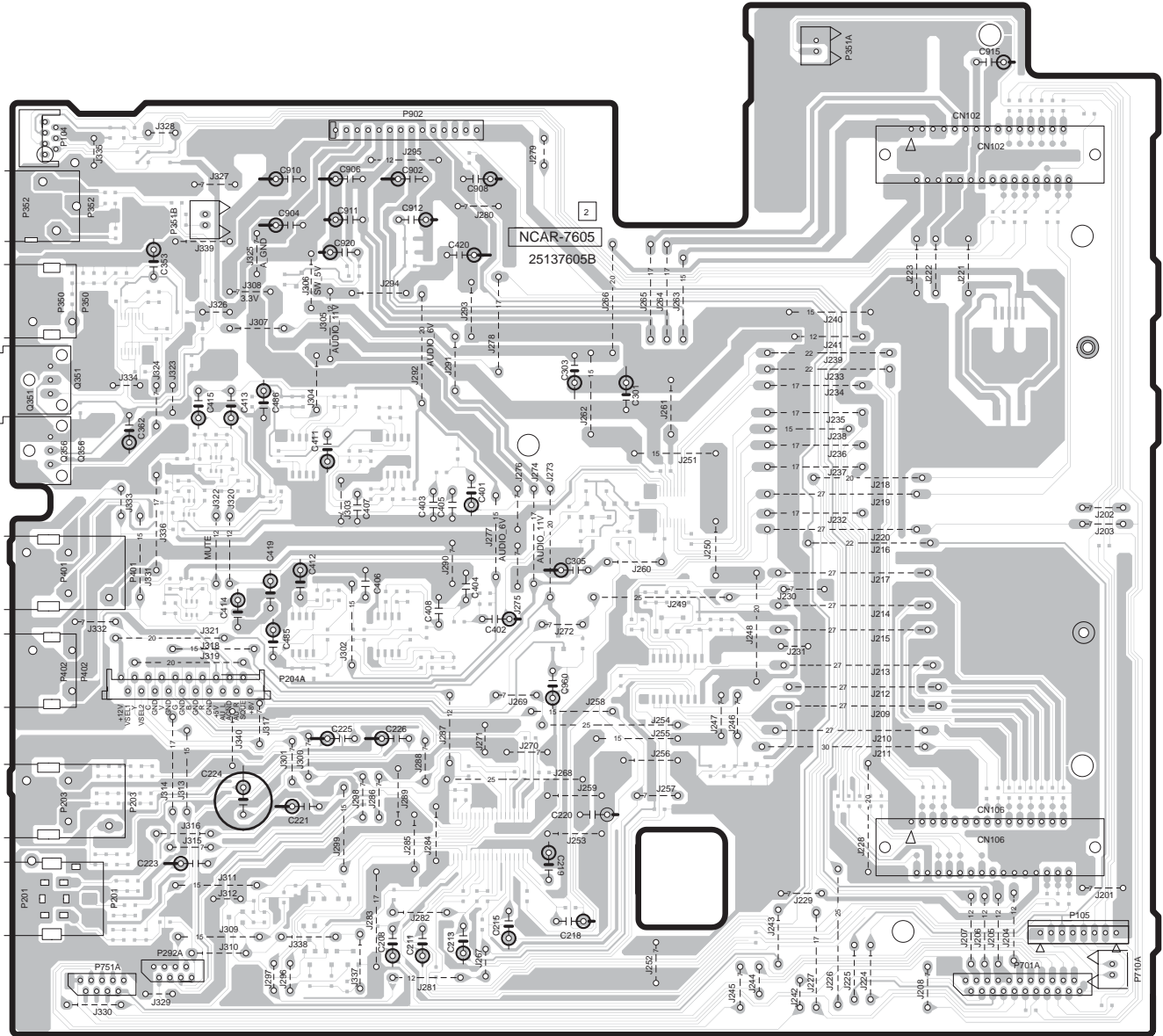

Component side

A

B

C

D

PRINTED CIRCUIT BOARD VIEW FROM SOLDERING SIDE-1

1

U1 : OUTPUT TERMINAL PC BOARD (NAAR-7605)

2

3

4

5

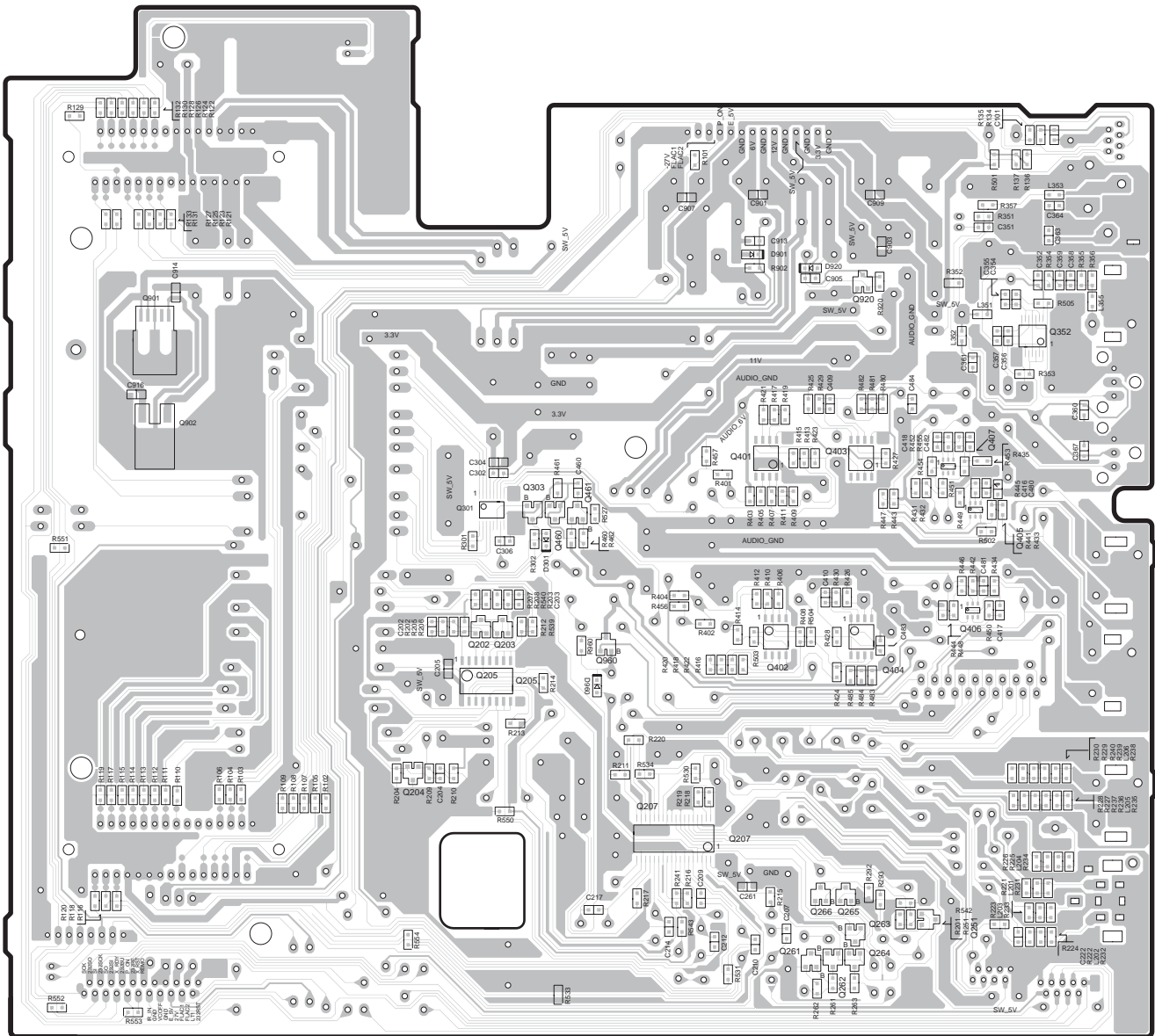

Soldering side

A

B

C

D

PRINTED CIRCUIT BOARD VIEW FROM SOLDERING SIDE

1

U2: DISPLAY CIRCUIT PC BOARD (NADIS-7606)

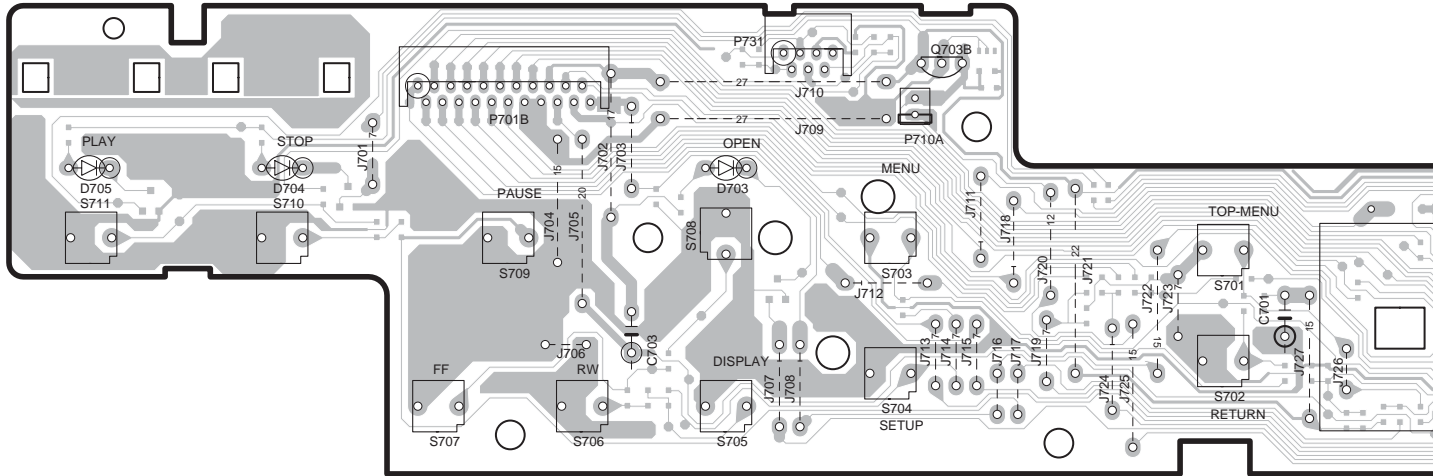

2

Componen

3

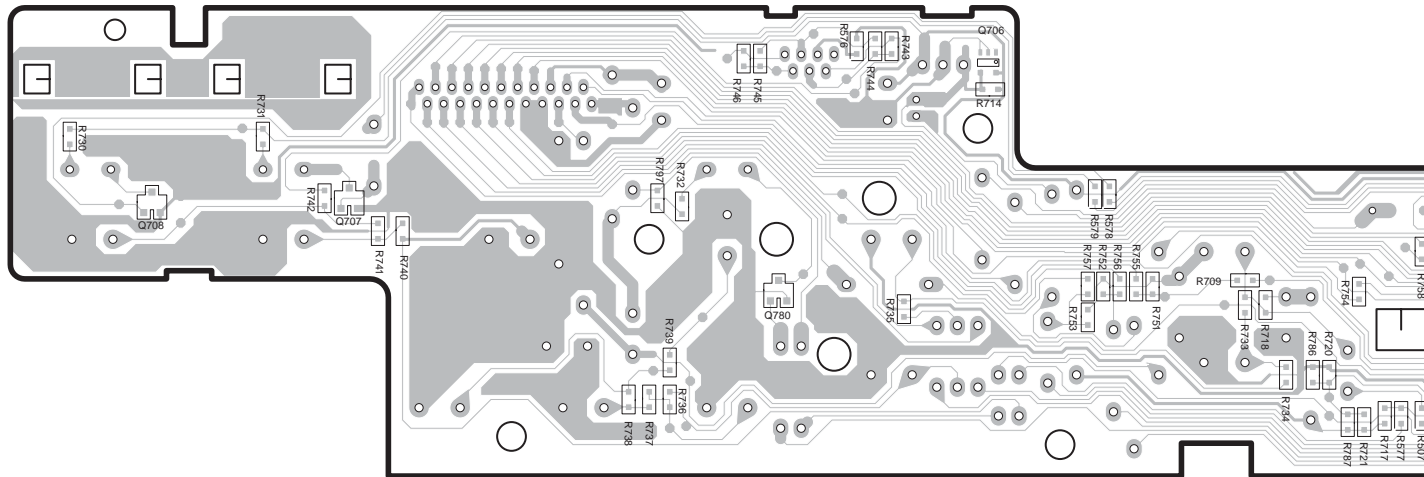

4

Sold

5

E

F

G

H

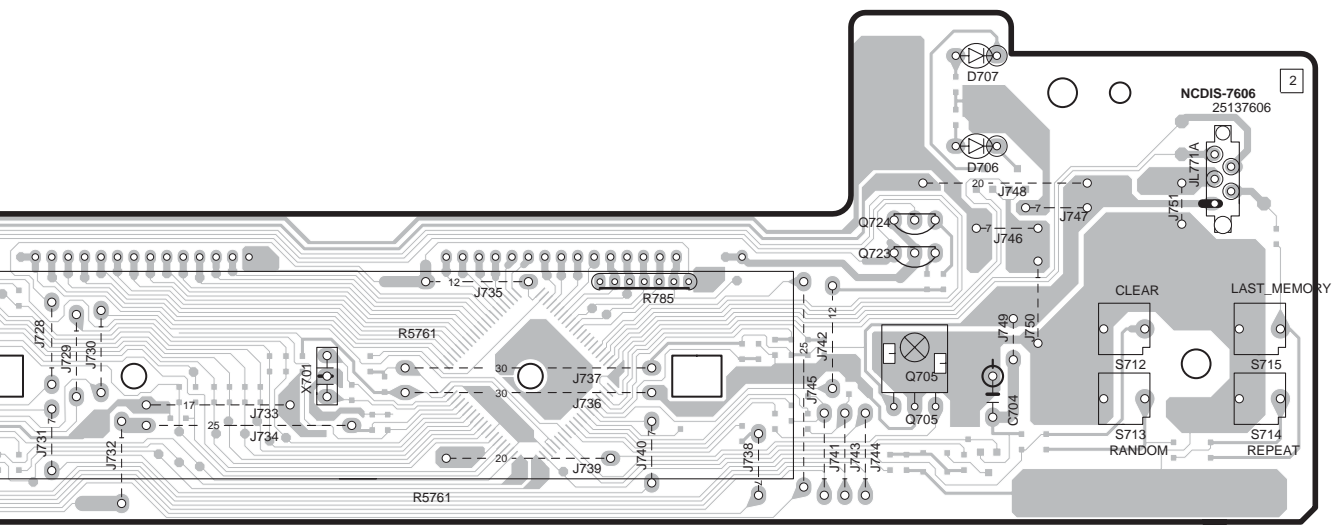

Component side view

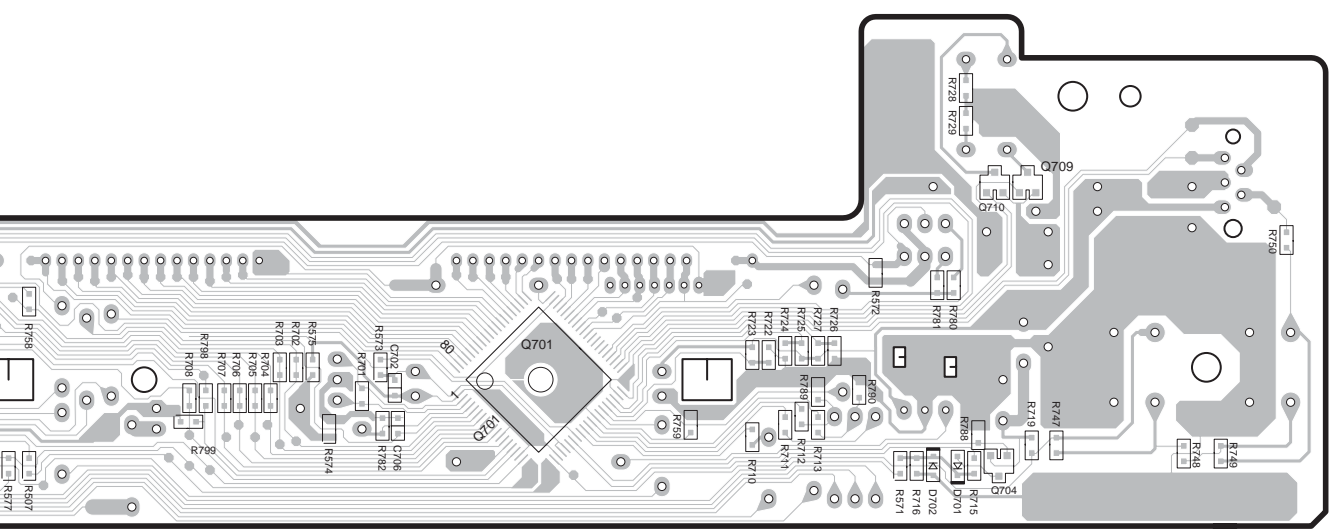

Soldering side view

A B C D E F G H

PRINTED CIRCUIT BOARD VIEW

1
2
3
4
5

U5: STANDBY LED PC BOARD (NADIS-7612)

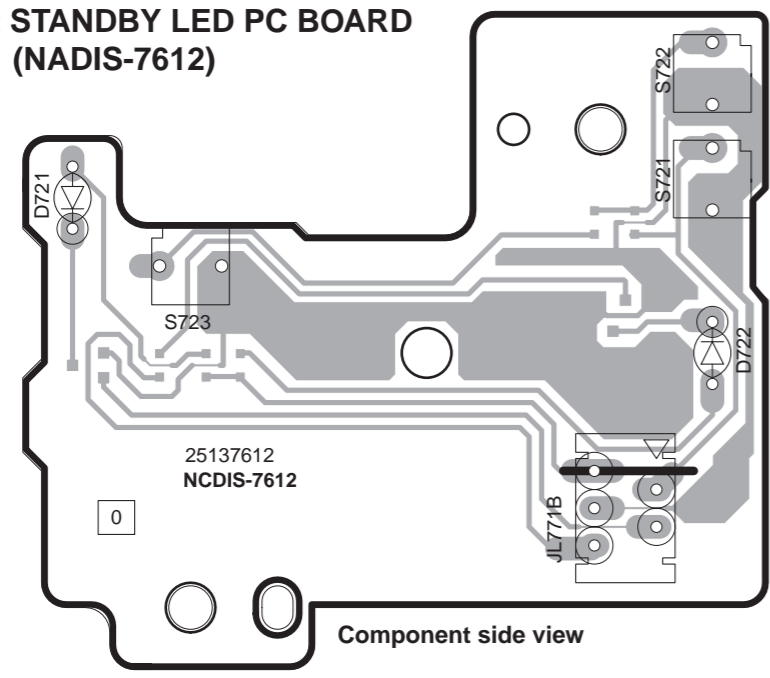

Component side view

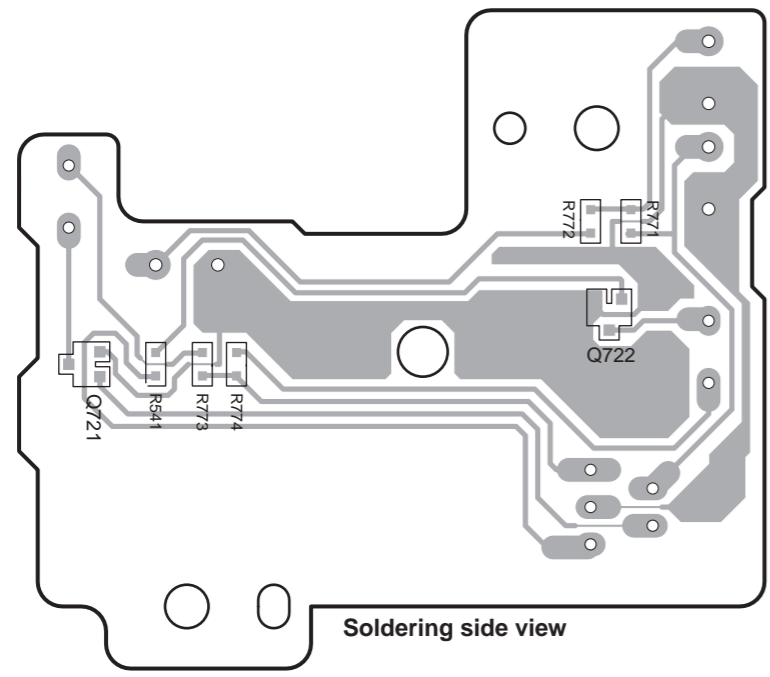

Soldering side view

U6: POWER SWITCH PC BOARD (NASW-7613)

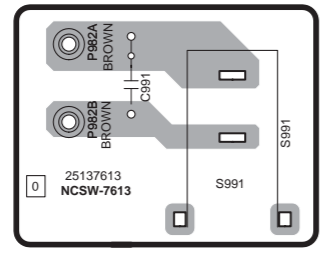

Component side view

U7: SCART TERMINAL PC BOARD (NAETC-7614)

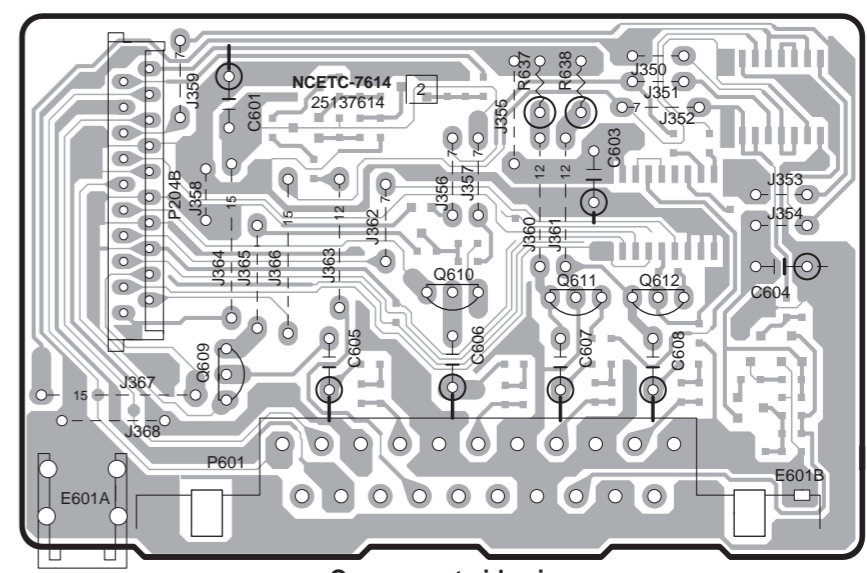

Component side view

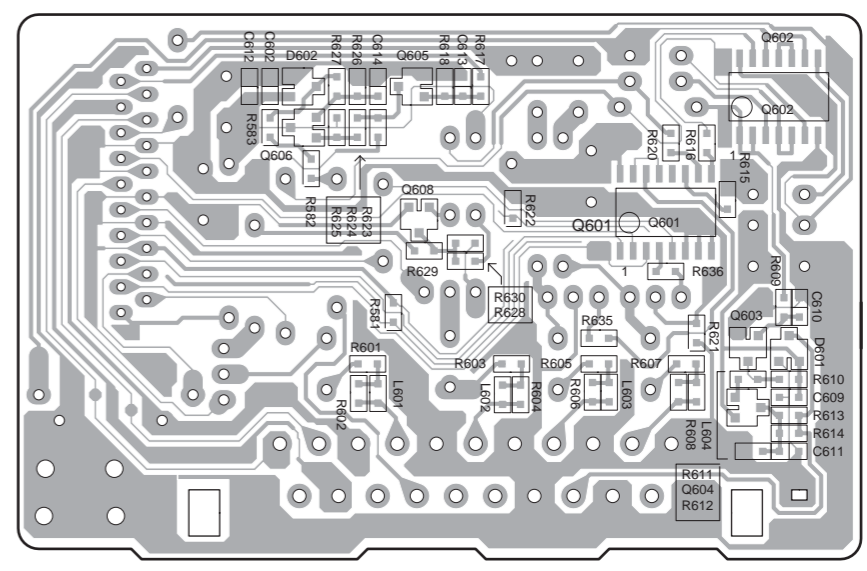

Soldering side view

U3: INLET TERMINAL PC BOARD (NAPS-7610)

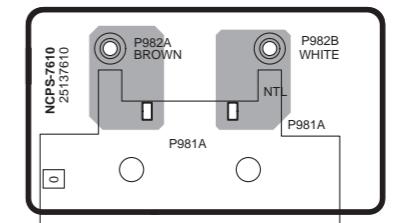

Component side view

U7: SCART TERMINAL PC BOARD (NAETC-7614)

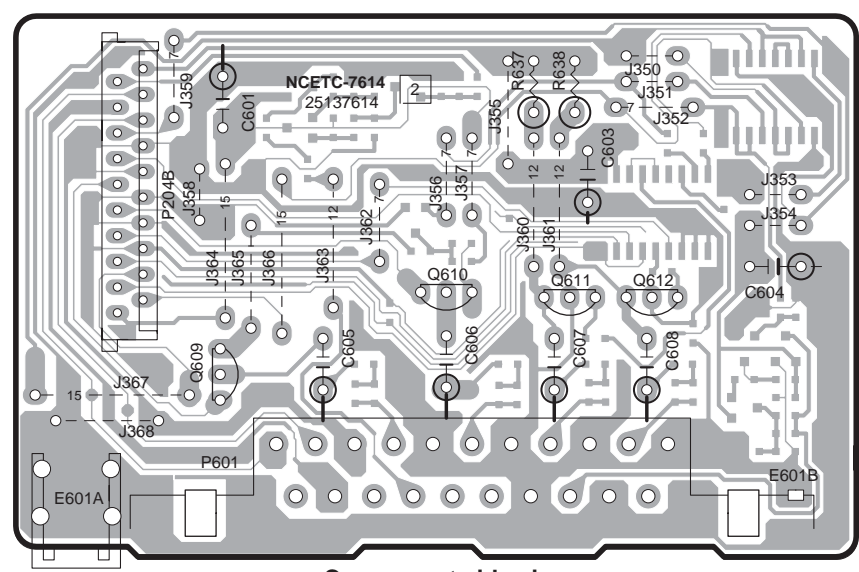

Component side view

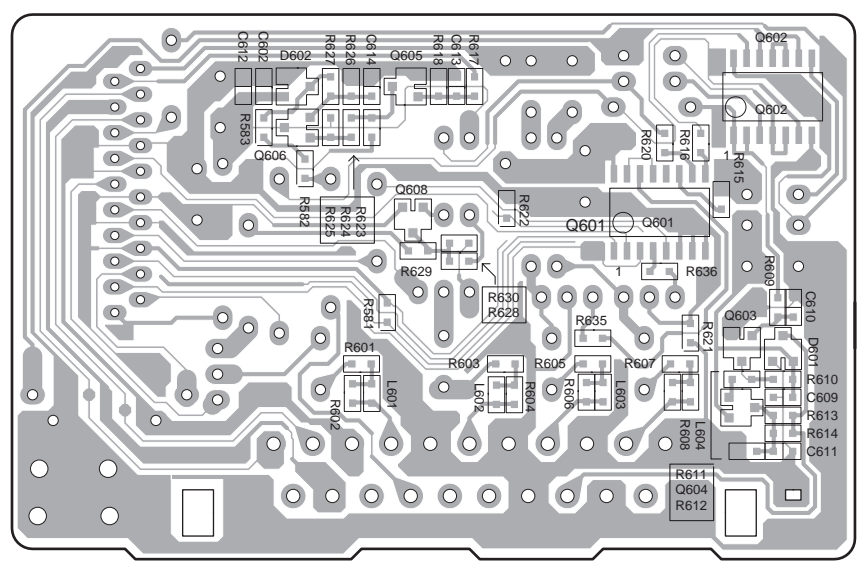

Soldering side view

U3: INLET TERMINAL PC BOARD (NAPS-7610)

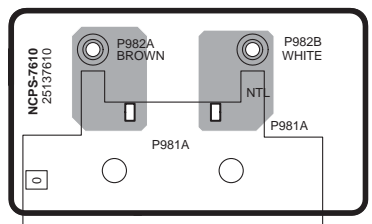

Component side view

A

B

C

D

PRINTED CIRCUIT BOARD VIEW

U5: STANDBY LED PC BOARD (NADIS-7612)

1

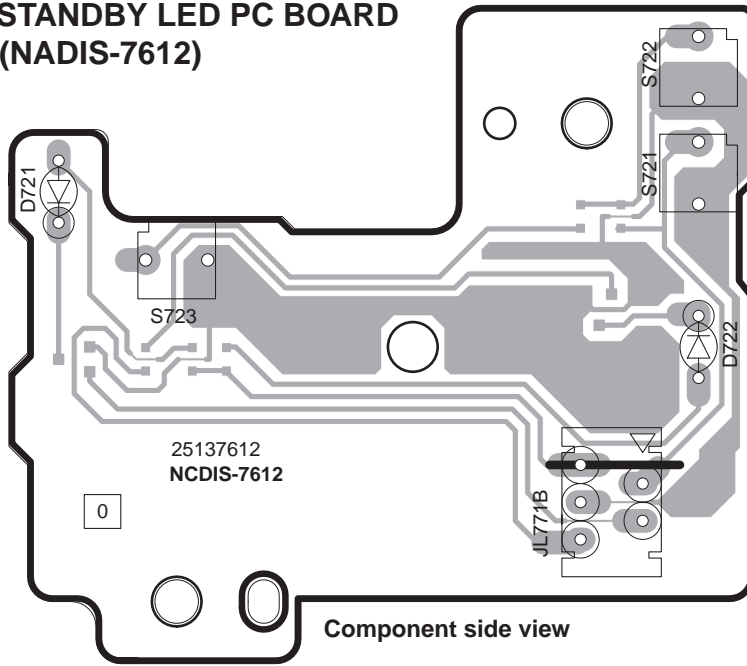

2

3

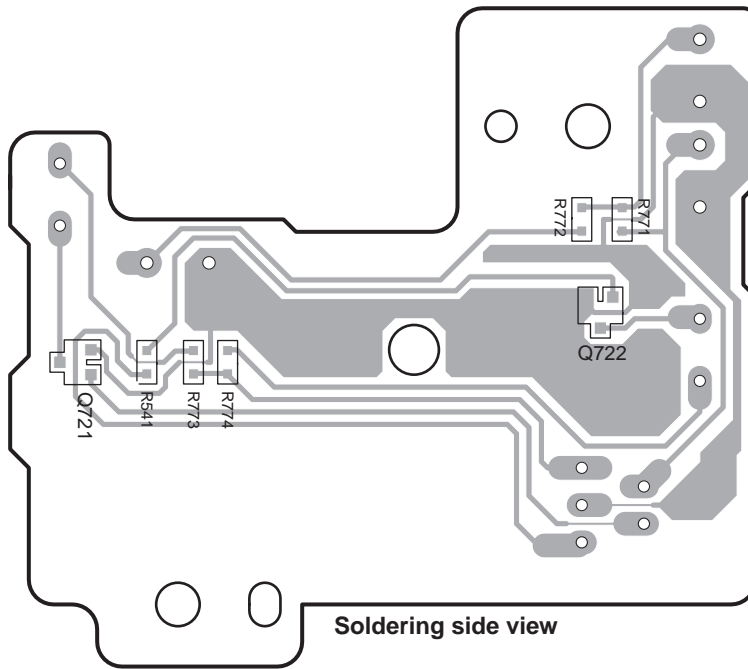

4

U6: POWER SWITCH PC BOARD (NASW-7613)

5

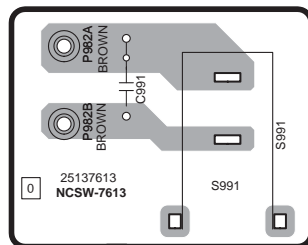

Component side view

PRINTED CIRCUIT BOARD PARTS LIST-1

**U1 : OUTPUT TERMINAL PC BOARD
(NAAR-7605-1A/1B/1C/1D/1F))**

U1 : OUTPUT TERMINAL PC BOARD (NAAR-7605-1A/1B/1C/1D/1F))			CIRCUIT NO.	PART NO.	DESCRIPTION
				Pin jacks	
			P201	25045656	NPJ-5PDBY456
			P203	25045654	NPJ-3PDGLR454 Except <MUP>
			P350	25045548	NPJ-1PDOR369
			P351A	25056159	NPLG-2P1098
			P351B	25056159	NPLG-2P1098
			P352	25045589	NPJ-2PDB400
			P401	25045655	NPJ-3PDBRW455
				Socket AS	
			P902	2002A392815	NSAS-28P0742
				Capacitors	
			C213,C215, C218,C920	394641007	10uF, 16V, Elect. (VR)
			C219,C220	394621017	100uF, 6.3V, Elect. (VR)
			C221,C223, C307	394624717	470uF, 6.3V, Elect. (VR)
			C224	354721029 or 394621027	1000uF, 6.3V, Elect. Except <MUP>
			C225,C226	354724719 or 394624717	470uF, 6.3V, Elect. Except <MUP>
			C301,C303, C904,C908, C910,C411, C412	394622217	220uF, 6.3V, Elect. (VR)
			C353,C362, C701,C704	354721019 or 394621017	100uF, 6.3V, Elect. 100uF,6.3V, Elect. (VR)
			C305	393346707	47uF,50V, Elect. (VX)
			C307	394624717	470uF,6.3V, Elect. (VR)
			C401,C402, C413-C415, C419	393344707	47uF, 16V, Elect. (VX) 680pF+/-5%,50V, Plastic.
			C403-C406	374726814	
			C407,C408	374721024	1000pF+/-5%,50V, Plastic.
			C420,C902, C906	354742219 or 394642217	220uF, 16V, Elect.
			C703	355782209	22uF, 50V, Elect.
			C911	394641017	100uF, 16V, Elect. (VR)
			C912	394644707	47uF, 16V, Elect. (VR)
			C915	394622207	22uF, 6.3V, Elect. (VR)
			C960	394641007	10uF, 16V, Elect. (VR) <MUP>
				Switches	
			S701-S715	25035699	NPS-111-S662
			S721-S723	25035699	NPS-111-S662
				Shield plate	
			E601B	27150455	<MUP>
CIRCUIT NO.	PART NO.	DESCRIPTION			
	ICs				
Q205	22241228R2	TC74HC4053AF Except <MUP>			
Q207	22241767R2	LA73054			
Q301	22241617R2	DB-VCP301(PCM-1742KE)			
Q352	22274004HR2O	TC74VHCU04FT			
Q401-Q404	22241383R2 or 22240489R1NE	NJM4565M-D or MPC4570G2-T1(MST)			
Q902	22241835R2	BA25BCOFP			
	Transistors				
Q303,Q460	2216340R2 or 2216260R2	KRC107S or RN1407			
Q405-Q407	2216141R2	HN1C03F-B			
Q461	2216185R2 or 2214375R2	KTA1504-GR or 2SA1162-GR			
Q920	2216175R2 or 2213145R2	KTC3875-GR or 2SC2712-GR			
Q960	2216175R2 or 2213145R2	KTC3875-GR or 2SC2712-GR <MUP>			
	Photo coupler				
Q351	24120093	JFJ3000			
	Diodes				
D301	223234R2 223269R2	1SS352 or 1SS355, Chip			
D901	224550510R2	UDZS5.1B, Zener			
D920	224551100R2	UDZS11B, Zener			
D960	224550820R2	UDZS8.2B, Zener <MUP>			
	Coils				
L201-L203	230958R1 or 230968R1	BK1608LM182-T or FBM-10-160808-202T, EMI Filter			
L204-L206	230958R1 or 230968R1	BK1608LM182-T or FBM-10-160808-202T Except <MUP>			
L351-L353, L355	230958R1 or 230968R1	BK1608LM182-T or FBM-10-160808-202T			
	Sockets				
CN102,CN106	25052610	NSCT-30P-2507			
P104	25052344 or 25051889 or 25052528	NSCT-7P2241 or NSCT-7P1676 or NSCT-7P2425			
P204A	25052216 25051827 25052029	NSCT-20P2113 or NSCT-20P1614 or NSCT-20P1816 <MUP>			
P701A	25052322 25051946 25052516	NSCT-22P2219 or NSCT-22P1733 or NSCT-22P2413			

NOTE : <MUP> European model

PRINTED CIRCUIT BOARD PARTS LIST-2

U2 : DISPLAY CIRCUIT PC BOARD (NADIS-7606-1A/1B/1C/1D/1F))

CIRCUIT NO.	PART NO.	DESCRIPTION
ICs		
Q701	22241880R3	MPD780232GC-077-8BT
Q706	22241841R2	BD4746G
Transistors		
Q704	2216230R2	KRA103S
Q704 or	2214540R2	RN2403
Remote sensor		
Q705	241336 or	PIC-37043TH2 or
Q705 or	241329	PIC-26043TH2
Oscillator		
X701	3010242	CST5.00MGW
Diodes		
D701	223234R2 or	1SS352 or
D701 or	223269R2	1SS355, Chip
D702	224550560R2	UDZS5.6B, Zener
Sockets		
P701B	25052359 or	NSCT-22P2256 or
	25051904 or	NSCT-22P1691 or
	25052543	NSCT-22P2440
P731	25052344 or	NSCT-7P2241 or
	25051889 or	NSCT-7P1676 or
	25052528	NSCT-7P2425
FL Tube		
Q702A	212233	14-BT-100GNK
FL Holder		
Q702B	27191141	
Wire tie		
JL771A	25051089	NSCT-5P876
U3 : INLET TERMINAL PC BOARD (NAPS-7610-1A/1B/1C/1D/1F)		
CIRCUIT NO.	PART NO.	DESCRIPTION
Terminal		
P981A	25056027	NPLG-2P977 Except <MDD/MDC>
P981A	25056006	NPLG-2P956 <MDD/MDC>
Socket AS		
P982B	2009990661UL	NSAS-2P0921
Crimp AS		
P982A	2069943301UL	

<MDD> : U.S.A. model only
 <MDC> : Canadian model only
 <MUT>: Asia, Oceania aria only
 <MUK> : Korea model only
 <MUS> : South American model only
 <MUR> : Chinese model only
 <MUP> : European model only

U5 : STANDBY LED PC BOARD (NADIS-7612-1A/1B/1C/1D/1F))

CIRCUIT NO.	PART NO.	DESCRIPTION
Transistor		
Q721	2216340R2 or	KRC107S or
	2216260R2	RN1407
LED		
D721	225290	SEL4110R, Standby
Plug		
JL771B	25055626	NPLG-5P588

U6 : POWER SWITCH PC BOARD (NASW-7613-1A/1B/1C/1D/1F)

CIRCUIT NO.	PART NO.	DESCRIPTION
Switch		
S991	25035703 or	NPS-111-L666P or
	25035550	NPS-111-L512P
Capacitor		
C991	3500196S	RE275V-103M, IS Cap.

U7 : SCART TERMINAL PC BOARD (NAETC-7614-1F) <MUP> only

CIRCUIT NO.	PART NO.	DESCRIPTION
ICs		
Q601	222840531R2O	TC4053BF
Q602	222740007R2O	TC74HCT00AF
Transistors		
Q603-Q606	2216174R2 or	KTC3875-Y or
	2213144R2 or	2SC2712-Y or
	2213145R2 or	2SC2712-GR or
	2216175R2	KTC3875-GR
Q608	2216190R2 or	KRC102S or
	2214470R2	RN1402
Q609,Q610	2211705 or	2SD655-E or
	2211706 or	2SD655-F or
	2216002	KTC2874-B
Q611,Q612	2213354 or	2SA933S-R or
	2213355 or	2SA933S-S or
	2215995	KTA1267-GR
Diodes		
D601,D602	223266R2	1SS226
Coils		
L601-L604	230958R1 or	BK1608LM182-T or
	230968R1	FBM-10-160808-202T
Sockets		
P204B	25052216 or	NSCT-20P2113 or
	25051827 or	NSCT-20P1614 or
	25052029	NSCT-20P1816
P601	25052279 or	NSCT-21P2176 or
	25052706	NSCT-21P2602
Capacitors		
C601,C603	354741019 or	100uF,16V, Elect.
	394641017	
C604	394621017 or	100uF,6.3V, Elect.
	354721019	
C605-C608	394624717 or	470uF,6.3V, Elect.
	354724719	

MICROPROCESSOR TERMINAL DESCRIPTION

Q701 : uPD780232GC

No.	SYMBOL	FUNCTION	I/O	DESCRIPTION	No.	SYMBOL	FUNCTION	I/O	DESCRIPTION
1	VDD1	VDD1		Power supply, +5V	41	P45/FIP37	SMP192LED	O	Sampling rate 192LED control output pin
2	VSS1	VSS1		Ground pin	42	P44/FIP36	SAMP96LED	O	Sampling rate 96LED control output pin
3	X1	X1		Main clock input pin (5MHz)	43	P43/FIP35	PLYLED	O	Play LED control output pin
4	X2	X2		Main clock input pin (5MHz)	44	P42/FIP34	STPLED	O	Stop LED control output pin
5	IC	IC	I	Ground pin	45	P41/FIP33	OPCLEL	O	Open/ Close LED control output pin
6	RESET	RESET	I	Reset pin of microprocessor	46	P40/FIP32	LED0	O	General LED control pin
7	P27/~SCK1	XSCK	O	Clock output pin for writing of flash ROM	47	P37/FIP31	PAUSELED	O	Pause LED control output pin
8	P26/SI1	SI	I	Data input pin for writing of flash ROM	48	P36/FIP30	SMP48LED	O	Sampling rate 48kHz LED control output pin
9	P25/SO1	SO	O	Data output pin for writing of flash ROM	49	P35/FIP29	POWERLED	O	Power LED control output pin
10	P24/BUSY	XRDY	O	XRDY output pin	50	P34/FIP28	P15	O	FL segment (P15) control output pin
11	P23	PON	O	Power ON control signal output pin (Power on: "H")	51	P33/FIP27	P14	O	FL segment (P14) control output pin
12	P22	SYSRESET	O	Reset control output pin	52	P32/FIP26	P13	O	FL segment (P13) control output pin
13	P21/SO3	---	I	Not used	53	P31/FIP25	P12	O	FL segment (P12) control output pin
14	P20/~SCK3	LT1	I	LT1 data input pin	54	P30/FIP24	P11	O	FL segment (P11) control output pin
15	P00/INTP0	~REMO	I	Remote signal input pin. Active "L"	55	FIP23	P10	O	FL segment (P10) control output pin
16	P01/INTP1	~IRIN	I	RI remote control input signal.	56	FIP22	P9	O	FL segment (P9) control output pin
17	P02/VI	VCOFF	O	Video circuit off control output pin	57	FIP21	P8	O	FL segment (P8) control output pin
18	AVSS	AVSS		Ground pin for D/A converter	58	FIP20	P7	O	FL segment (P7) control output pin
19	ANI3	INIT1	I	Initializing input pin (Analog signal)	59	VDD2	VDD2		Power supply pin (+5V)
20	ANI2	ANI2	I	Analog input pin for A/D converter	60	VLOAD	VLOAD		FIP control pin to connect pull down resistor.
21	ANI1	ANI1	I	Analog input pin for A/D converter	61	FIP19	P6	O	FL segment (P6) control output pin
22	ANI0	ANI0	I	Analog input pin for A/D converter	62	FIP18	P5	O	FL segment (P5) control output pin
23	VSS0	VSS0		Ground pin	63	FIP17	P4	O	FL segment (P4) control output pin
24	AVDD	AVDD		Power supply pin of D/A converter, +5V	64	FIP16	P3	O	FL segment (P3) control output pin
25	VDD0	VDD0		Power supply, +5V	65	FIP15	P2	O	FL segment (P2) control output pin
26	P64/FIP52	SYSIN	I	System buss input pin	66	FIP14	P1	O	FL segment (P1) control output pin
27	P63/FIP51	~SYSOUT	O	System buss output pin	67	FIP13	14G	O	FL grid (G14) output pin
28	P62/FIP50	R232REQ	I	REQ input pin from microprocessor of RS-232C driver	68	FIP12	13G	O	FL grid (G13) output pin
29	P61/FIP49	R232BUSY	I	BUSY input pin from microprocessor of RS-232C driver	69	FIP11	12G	O	FL grid (G12) output pin
30	P60/FIP48	R232SI	I	SI input pin from microprocessor of RS-232C driver	70	FIP10	11G	O	FL grid (G11) output pin
31	P57/FIP47	R232SCK	O	SCK output pin from microprocessor of RS-232C driver	71	FIP9	10G	O	FL grid (G10) output pin
32	P56/FIP46	R232SO	O	SO output pin from microprocessor of RS-232C driver	72	FIP8	9G	O	FL grid (G9) output pin
33	P55/FIP45	TEST	I	Testing pin	73	FIP7	8G	O	FL grid (G8) output pin
34	P54/FIP44	R232RES	O	Reset control output pin to microprocessor of RS-232C driver	74	FIP6	7G	O	FL grid (G7) output pin
35	P53/FIP43	FLON_OFF	O	FL filament on/off control output pin	75	FIP5	6G	O	FL grid (G6) output pin
36	P52/FIP42	MSO_2	I	Model select input pin 2	76	FIP4	5G	O	FL grid (G5) output pin
37	P51/FIP41	MSO_1	I	Model select input pin 1	77	FIP3	4G	O	FL grid (G4) output pin
38	P50/FIP40	MSO_0	I	Model select input pin 0	78	FIP2	3G	O	FL grid (G3) output pin
39	P47/FIP39	STBYLED	O	Standby LED control output pin	79	FIP1	2G	O	FL grid (G2) output pin
40	P46/FIP38	VCOFFLED	O	Video circuit off control output pin	80	FIP0	1G	O	FL grid (G1) output pin

Disassembly of the Traverse Mechanism Assy-1

- ① Remove the top cover and Tray Panel.
- ② Remove the Tray panel and Front Panel.
- ③ Remove the Bridge (Screw 1).
- ④ Pull out the Tray and remove it while unhooking a Hook.
- ⑤ Turn the Short SW to Short side.
- ⑥ Remove three connectors.

• RearView

DVD main PCB side

Short → Open

Short SW

Caution in the tray insertion

In the Tray insertion, insert it after matching a triangle mark of the Loading Base and a position of pin of the Drive Cam.

Triangle mark

Loading Base

Pin

Drive Cam

- ⑦ Remove the Loading Mechanism Assy (Screws 4).
- ⑧ Remove a screw.

Cautions:
Screw is locked with Silicone Adhesive.
Please lock it with Silicone Adhesive when installs it.

- ⑨ Remove the FFC Holder with the state which Flexible Cable was attached.

• Bottom View

Pickup assy

• When Removing The Traverse Mechanism Assy

- ⑩ Remove the Pickup Flexible Cable
- ⑪ Unhook (4)
- ⑫ Remove the Traverse Mechanism Assy

Exchange

Next

Disassembly of the Traverse Mechanism Assy-2



● When Removing The Pickup Assy

- ⑩ Remove the Pickup Flexible Cable.

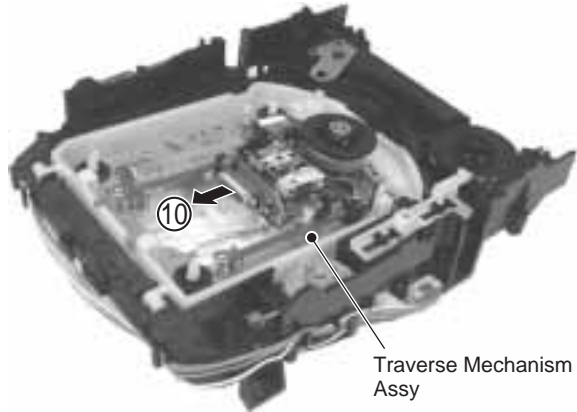

- ⑪ Remove two Skew Screws and two Skew Springs.

- ⑫ Remove the Pickup Assy.

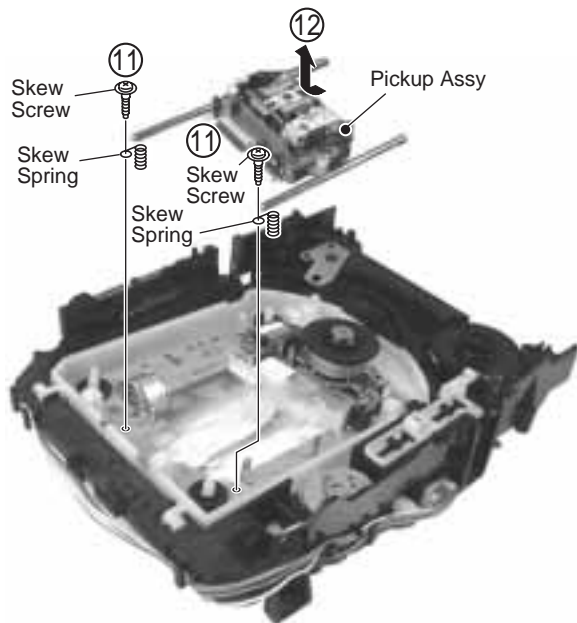

- ⑬ Remove two screws.

Cautions:

Screw is locked with Screw Lock.
Please lock it with Screw Lock when installs it.

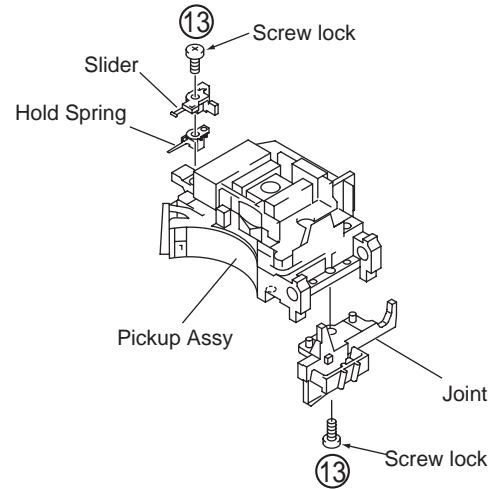

Exchange

Disassembly of the Traverse Mechanism Assy-3

☞ Styling the Pickup Flexible Cable

- ① Fold a edge of lining part of the Pickup Flexible Cable.
- ② Insert the Pickup Flexible Cable in connector, and lock it surely.

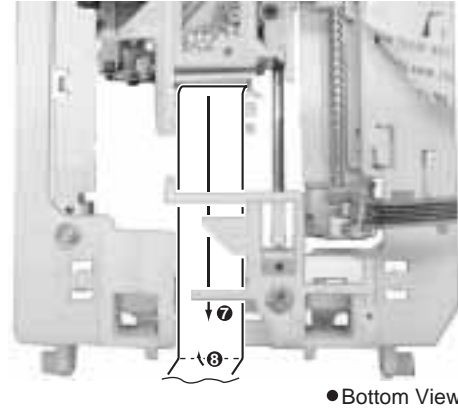
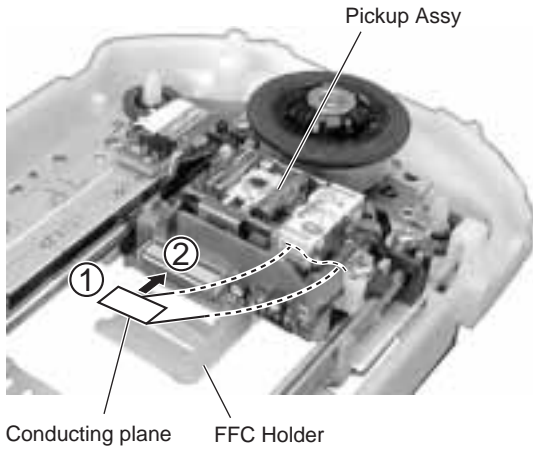

Caution:
Move the Pickup to the innermost of the disc.

- ③ Perform the styling as shown in figure below.

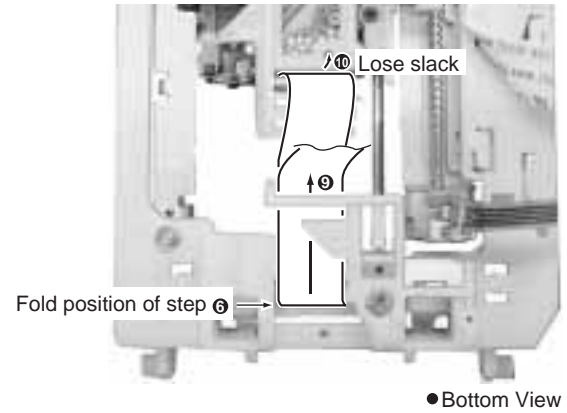
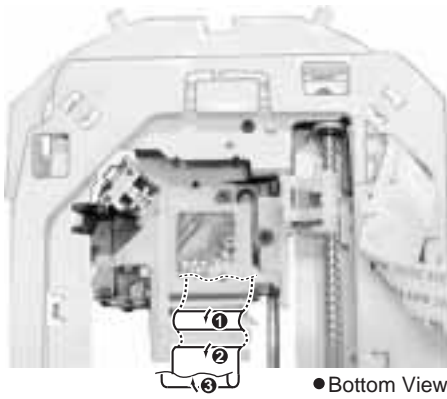

Fold it at the position of reference line.

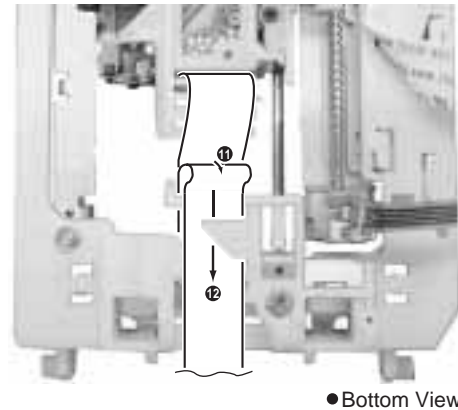
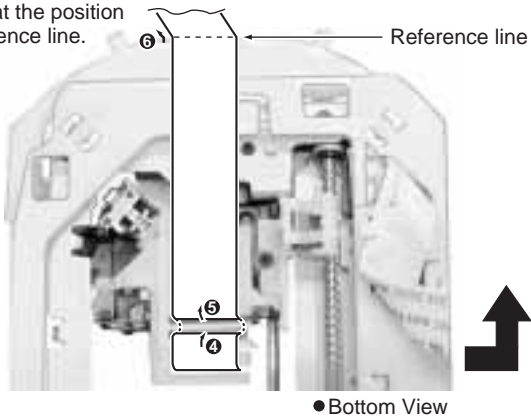

ADJUSTMENT PROCEDURE-1

ADJUSTMENT ITEMS AND LOCATION

Adjustment Items

[Mechanism Part]

- ① Tangential and Radial Height Coarse Adjustment
- ② DVD Jitter Adjustment
- ③ Initialize the Focus Sweep Setting

[Electrical Part]



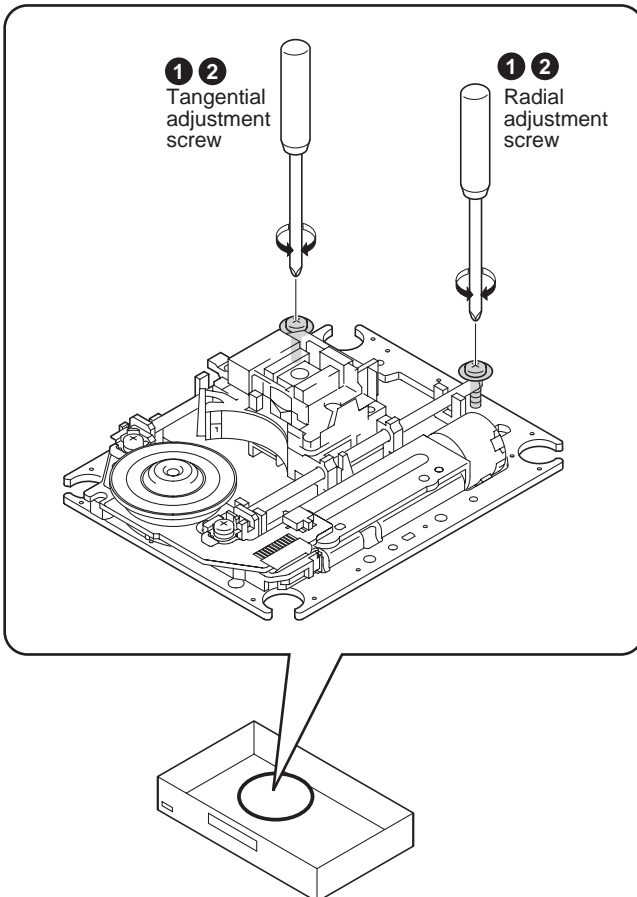

Electrical adjustments are not required.

Adjustment Points (Mechanism Part)

Cautions: After adjustment, adjustment screw locks with the Screw tight.

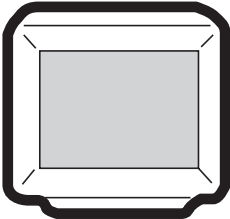

JIGS AND MEASURING INSTRUMENTS

 <p>⊕ Screwdriver (large)</p>	 <p>⊕ Screwdriver (medium)</p>
 <p>TV monitor</p>	<p>Screw light</p>
 <p>⊕ Precise screwdriver</p>	

ADJUSTMENT PROCEDURE-2

MECHANISM ADJUSTMENT

1 Tangential and Radial Height Coarse Adjustment

START

Remove the servo mechanism.
Remove a Spacer for height adjustment attached to the back side (shaded area) of the Servo Mechanism (Float Base) with nippers.

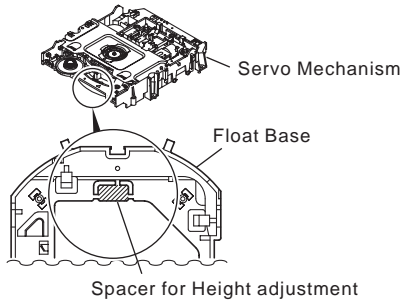

Note:
Turn the Short switch to Short side when removing the Pickup Flexible Cable.

Cautions:

Because there is not a Spacer for height adjustment in adjustment after the second time, will keep it at need.
(This parts is Traverse mechanism exclusive use of a model for 2001 years)



Put a spacer between a Tangential (or Radial) adjustment screw and Mechanism Base and turn each screw to adjust the height.

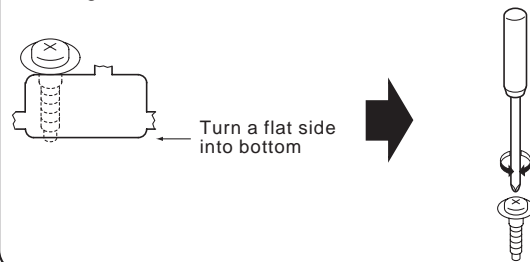

ADJUSTMENT PROCEDURE-3

NECESSARY ADJUSTMENT POINTS

When
Exchange Parts of Mechanism Assy

Adjustment Points

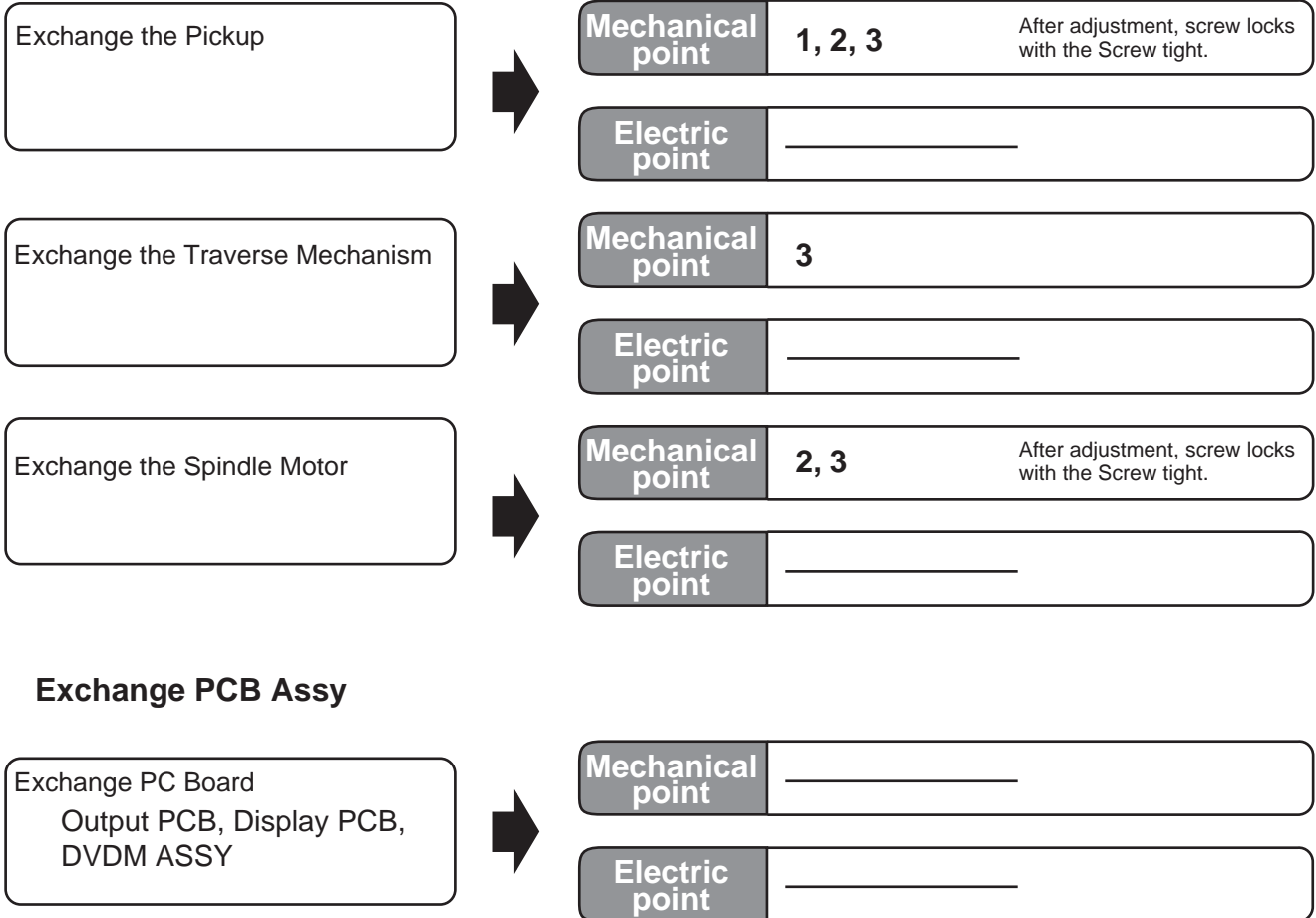

UPGRADE OF FIRMWARE-1

Preparation

Remote controller
Part No. 24140451S

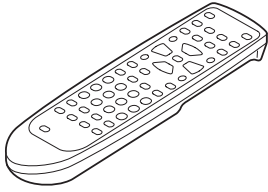

Same as DV-S757 or DV-S555

Interface jig

Part No. 0J13



Part No. GGF1348



or

RS-232C Cable (Straight type)

When used 0J13

D-Sub 9 pin
(Male)



D-Sub 9 pin
(Female)



When used GGF1348

D-Sub 25 pin
(Male)



D-Sub 9 pin
(Female)



or

Flexible Flat Cable
Part No.: GGD1231 or 0F001

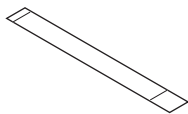

Video Cable



PC

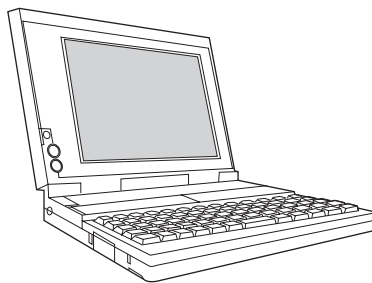

Monitor

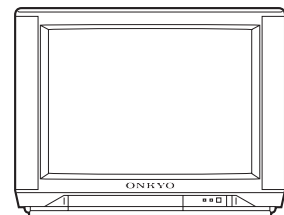

UPGRADE FIRMWARE-2

Connections

Rear panel view

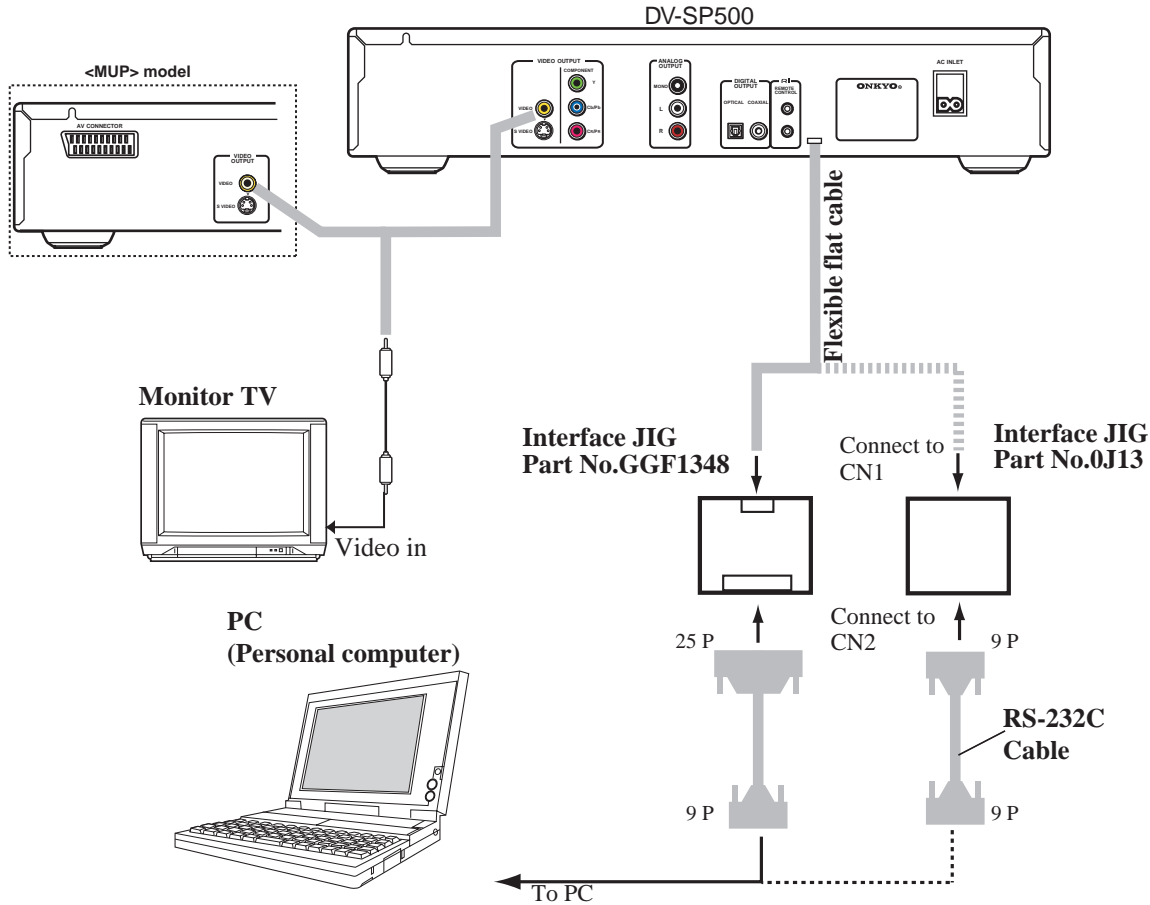

Prepare the file required for rewriting of the firmware.

Build the folder to C drive of the hard disk of PC, and put in the file required for the folder.

1. ok_down.exe

NOTE: This is one example.

1. ok_down.exe
Rewriting tools

2. down.bat
Rewriting tools

3. b1ck1048.sz0
Firmware program

The file name changes with versions of the firmware.

When new FW program is required, Please ask to ONKYO Technical Information Group.

EX)

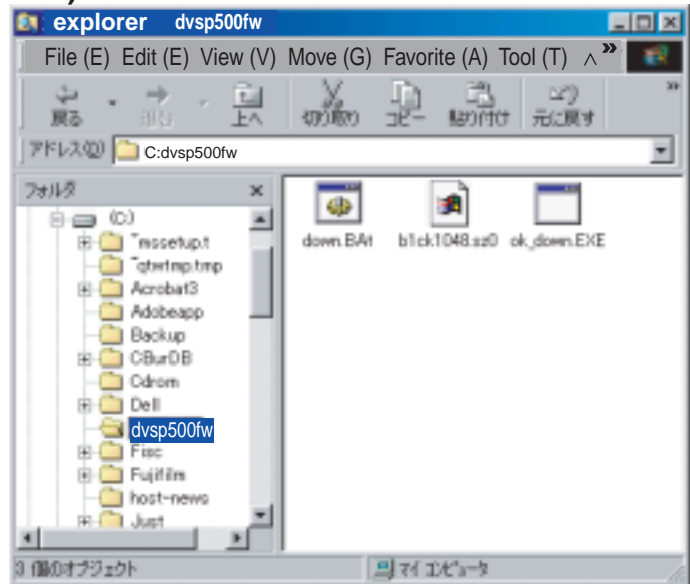

UPGRADE FIRMWARE-3

Download procedures

[NOTES]

This procedure's picture is using Japanese PC.

The program file name and the folder name etc. are examples.

1. Start, MS-DOS prompt using the start-up menu of PC.

Windows of MS DOS prompt

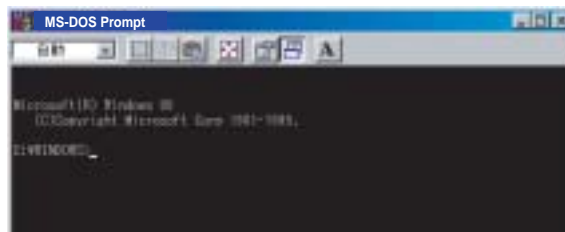

EX)

Microsoft(R) Windows 98
(C)Copyright Microsoft Corp 1981-1999

C:\WINDOWS> cd..

C:\>cd dvsp500fw

C:\dvsp500fw>down b1bk112z.sz0

C:\¥ WINDOWS>_
2. Key input "cd..". and ENTER key.

C:\¥ >_
3. Press the Enter ↵ button, after inputting **cd dvsp500fw** by the keyboard.
Space | Zero

C:\¥ dvssp500fw>_
4. Press the Enter ↵ button, after inputting **down b1bk112z.sz0** by the keyboard.
Space | Zero

b1bk112z.sz0 : The program fail name
The file name changes with versions of FW.

5. >MO ↵

6. >SZL ↵

Wait about 4 minutes, and completed.

UPGRADE FIRMWARE-4

7. Setting the Region code.

When display the TV monitor is "RIGIN INI", key input the rigoinal code by remote controller.

* MDD1N and MJJ2N are automatically chosen. (Automatically witting)

Destination	RC-449DV (Slide SW: TV position)	Transmission Code	Region
MDD1N	*	*	1
MJJ2N	*	*	2
MUP2P	2	D22F 12	2
MUT3P	3	D22F 13	3
MUS4P	4	D22F 14	4
MUR6R	6	D22F 16	6

*: automatically chosen

Confirm of the FW

1. Press the **SETUP** key
2. Operate the **CURSOR** switch to make up the **Setup menu mode** are selected on monitor TV.
3. Press the **DISPLAY** button
The region and FW version information will appear on the monitor TV.

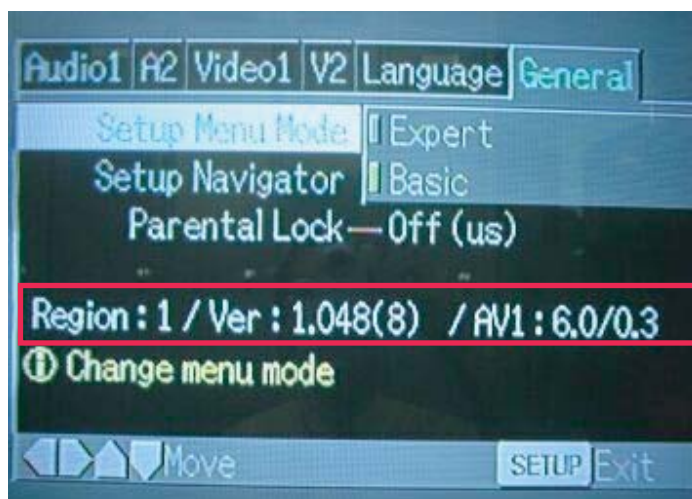

ERROR MESSAGE

ERROR CODE

Error codes that are displayed on the FL display without using the remote control unit

FL Display	Possible causes	Operation of the unit
AV1 VER	AV-1 chip is not a match with the program of system controller	The sound may not out with the specific audio.
CPU AERR	CPU address error (Hardware is unusual.)	No operation
DMA AERR	DMA address error (Hardware is unusual.)	No operation
FLASH ID	Difference in versions of the internal ROM of the system controller and of the flash ROM, or bus line failure or reverse installation	No operation
FLASH WRP	Write protect error of the flash ROM	No operation
FLASH SIG	Difference in part number of the flash ROM (When the ROM which could't be used was used.)	No operation
FLASH SUM	Check sum error of the flash ROM (It exceeds the regular size.) or reverse installation (Hardware is unusual.)	No operation
FLASH SIZE	Size error of the flash ROM (Use 4 or 8 M-bit.)	No operation
ILLGAL	The system controller fetched a code other than an operation code (Hardware is unusual.)	No operation
RESERVE	Undefined interrupt (Hardware is unusual.)	No operation
SLOT	Inappropriate slot command issued (Hardware is unusual.)	No operation
SDSP PWER	Access error to the servo DSP or clock does not oscillation (Hardware is unusual.)	Accept only OFF operation of the POWER key of the main unit. Remote control unit is impossible.

TROUBLE SHOOTING

No Power ON
 FL is not turned ON
 FL indication is unusual

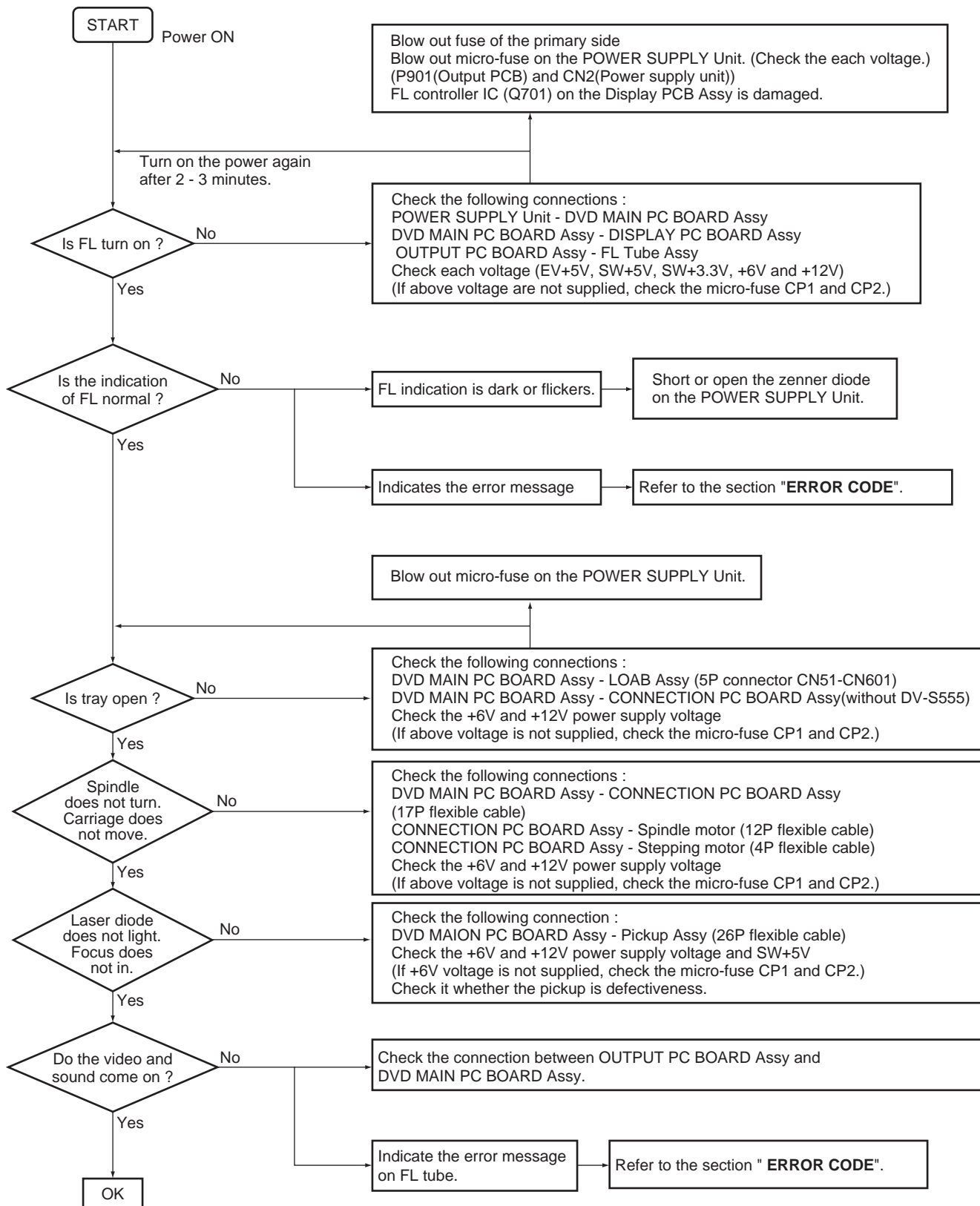

PACKING VIEW

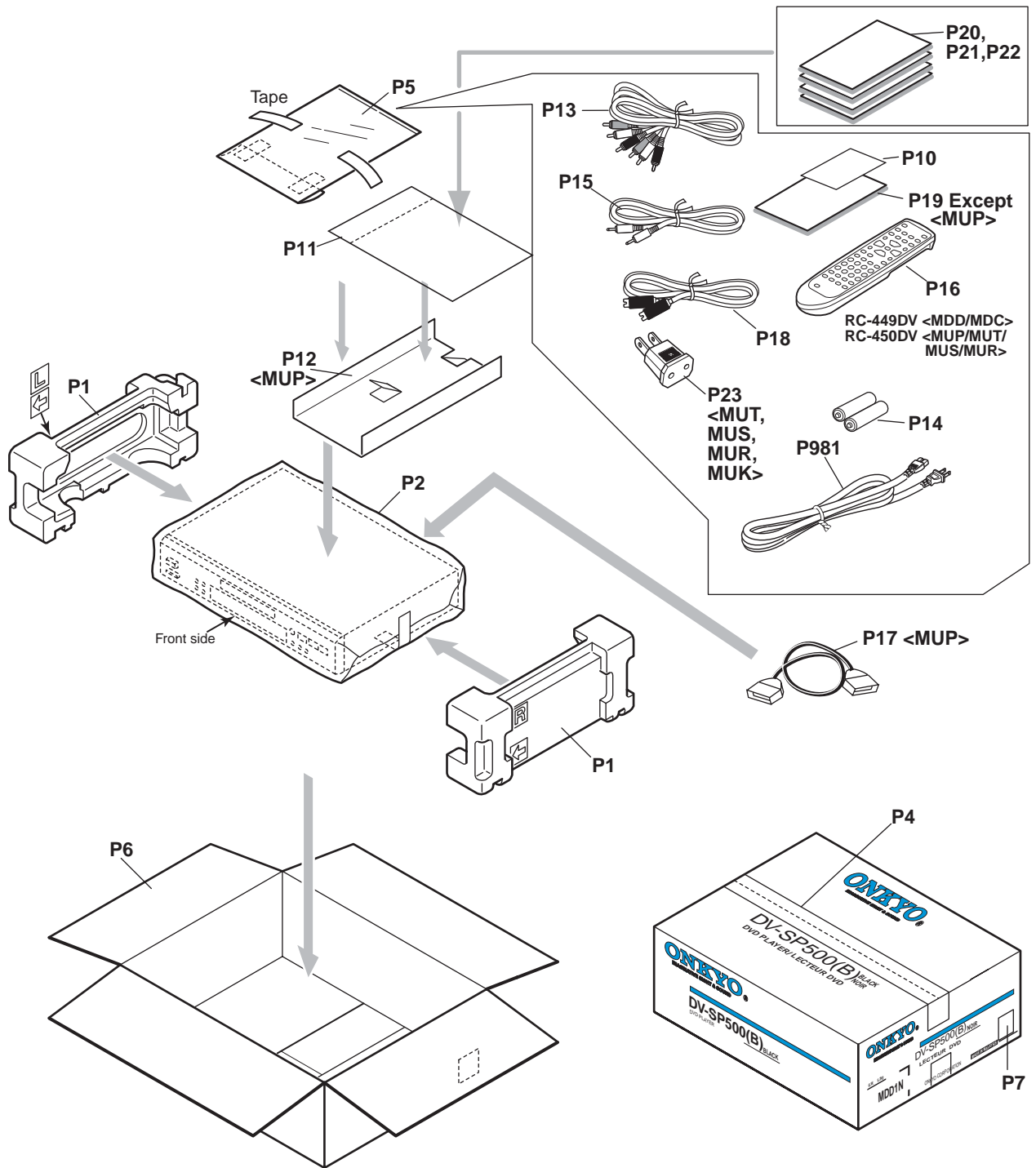

PACKING VIEW PARTS LIST

REF. NO.	PART NO.	DESCRIPTION	REF. NO.	PART NO.	DESCRIPTION
P1	29091986	Pad assy	P15	2010200	RI cord, 3.5-MINI PLUG
P2	29100037-1A	Poly bag, 650 x 500	P16	24140449	Remote controller, RC-449DV <MDD/MDC>
P4	29110148	PP Tape		24140450	Remote controller, RC-450DV <MUT/MUR/MUS/MUP>
P5	29100097-1A	Poly bag, 350 x 250	P17	2010411 or 2010368	RGB Cord, YAF11-1015 or YAF11-0697 <MUP>
P6	29053927	Carton box <B MUP>	P18	2010380 or 2010360	S Connection cable, TPX3000 <MDD/MDC/MUR/MUS>
	29053928	Carton box <S MUP>	P19	29343340	Instruction manual, E <MDD/ MDC/MUT/MUR/MUS/MUK>
	29053908	Carton box <B MDD/MDC>		29343372	Instruction manual, E <MUP>
	29053909	Carton box <B MUT>	P20	29343341	Instruction manual, U2FS <MUS/MDC>
	29053910	Carton box <B MUS>		29343342	Instruction manual, U2CTCS <MUT/MUR/MUK>
	29053911	Carton box <G MUT>	P21	29343373	Instruction manual, U3GDSw <MUP>
	29053912	Carton box <G MUS>	P22	29343374	Instruction manual, U3FSI <MUP>
	29053913	Carton box <G MUR>	P23	△ 25055911	CV Plug, CV-K-2 <MUT/MUS/MUR/MUK>
	29053911	Carton box <G MUK>	P981	△ 253296HIT	Power cord, AC-UC-2 <MDD/MDC>
P7	29363152	UPC Label assy <B MDD/B MDC>		△ 253299HIT or	Power cord, AS-CEE
	29363150	EAN Label assy <B MUT/ B MUS/ B MUP>		△ 253309HIT	Power cord, AS-CCEE <MUR>
	29363151	EAN Label assy <G MUS/ G MUT/G MUR/G MUK>		△ 253346VOL	Power cord, AS-KS <MUR> <MUT/MUS/MUK/MUP>
	29363181	EAN Label assy <S MUP>			
P10	29365090	Warranty card <MDD/MDC>			
P11	29100097-1A	Poly bag 350 x 250 <B MDD/ B MDC>			
P12	29092034	Pad , Top <MUP>			
P13	2010379	Pin coord assy, RCA3P(YWR)			
P14	3010194 or 3010054	Battry, UM-3			

**NOTE: THE COMPONENTS IDENTIFIED BY MARK △
ARE CRITICAL FOR RISK OF FIRE AND
ELECTRIC SHOCK. REPLACE ONLY WITH
PART NUMBER SPECIFIED.**

<MDD> : U.S.A. model only

<MDC> : Canadian model only

<MUT> : Asia, Oseania area, regional code 3,
video code PAL

<MUS> : South American model, regional
code 4, video code PAL

<MUR> : Chinese model only

<MUK> : Korea model, regional code 3,
video code PAL

<MUP> : European model only

 : Black color model

<G> : Golden color model

<S> : Silver color model

PACKING VIEW PARTS LIST

REF. NO.	PART NO.	DESCRIPTION	REF. NO.	PART NO.	DESCRIPTION
P1	29091986	Pad assy	P15	2010200	RI cord, 3.5-MINI PLUG
P2	29100037-1A	Poly bag, 650 x 500	P16	24140449	Remote controller, RC-449DV <MDD/MDC>
P4	29110148	PP Tape		24140450	Remote controller, RC-450DV <MUT/MUR/MUS/MUP>
P5	29100097-1A	Poly bag, 350 x 250	P17	2010411 or 2010368	RGB Cord, YAF11-1015 or YAF11-0697 <MUP>
P6	29053927	Carton box <B MUP>	P18	2010380 or 2010360	S Connection cable, TPX3000 <MDD/MDC/MUR/MUS>
	29053928	Carton box <S MUP>	P19	29343340	Instruction manual, E <MDD/ MDC/MUT/MUR/MUS/MUK>
	29053908	Carton box <B MDD/MDC>		29343372	Instruction manual, E <MUP>
	29053909	Carton box <B MUT>	P20	29343341	Instruction manual, U2FS <MUS/MDC>
	29053910	Carton box <B MUS>		29343342	Instruction manual, U2CTCS <MUT/MUR/MUK>
	29053911	Carton box <G MUT>	P21	29343373	Instruction manual, U3GDSw <MUP>
	29053912	Carton box <G MUS>	P22	29343374	Instruction manual, U3FSI <MUP>
	29053913	Carton box <G MUR>	P23	△ 25055911	CV Plug, CV-K-2 <MUT/MUS/MUR/MUK>
	29053911	Carton box <G MUK>	P981	△ 253296HIT	Power cord, AC-UC-2 <MDD/MDC>
P7	29363152	UPC Label assy <B MDD/B MDC>		△ 253299HIT or △ 253309HIT	Power cord, AS-CEE Power cord, AS-CCEE <MUR>
	29363150	EAN Label assy <B MUT/ B MUS/ B MUP>		△ 253346VOL	Power cord, AS-KS <MUR> <MUT/MUS/MUK/MUP>
	29363151	EAN Label assy <G MUS/ G MUT/G MUR/G MUK>			
	29363181	EAN Label assy <S MUP>			
P10	29365090	Warranty card <MDD/MDC>			
P11	29100097-1A	Poly bag 350 x 250 <B MDD/ B MDC>			
P12	29092034	Pad , Top <MUP>			
P13	2010379	Pin coord assy, RCA3P(YWR)			
P14	3010194 or 3010054	Battry, UM-3			

**NOTE: THE COMPONENTS IDENTIFIED BY MARK △
ARE CRITICAL FOR RISK OF FIRE AND
ELECTRIC SHOCK. REPLACE ONLY WITH
PART NUMBER SPECIFIED.**

<MDD> : U.S.A. model only

<MDC> : Canadian model only

<MUT> : Asia, Oseania area, regional code 3,
video code PAL

<MUS> : South American model, regional
code 4, video code PAL

<MUR> : Chinese model only

<MUK> : Korea model, regional code 3,
video code PAL

<MUP> : European model only

 : Black color model

<G> : Golden color model

<S> : Silver color model

ONKYO CORPORATION

Sales & Product Planning Div. : 2-1, Nisshin-cho, Neyagawa-shi, OSAKA 572-8540, JAPAN
Tel: 072-831-8111 Fax: 072-833-5222

ONKYO U.S.A. CORPORATION

18 Park Way, Upper Saddle River, N.J. 07458, U.S.A.
Tel: 201-785-2600 Fax: 201-785-2650 E-mail: onkyo@onkyousa.com

ONKYO EUROPE ELECTRONICS GmbH

Industriestrasse 20, 82110 Germering, GERMANY
Tel: 089-849-320 Fax: 089-849-3265 E-mail: info@onkyo.de

ONKYO CHINA LIMITED

Units 2102-2107, Metroplaza Tower I, 223 Hing Fong Road, Kwai Chung,
N.T., HONG KONG Tel: 852-2429-3118 Fax: 852-2428-9039

ICs BLOCK DIAGRAM / TERMINAL DESCRIPTION

Q601 : TC4053BF

Triple 2-Channel multiplexer / demultiplexer

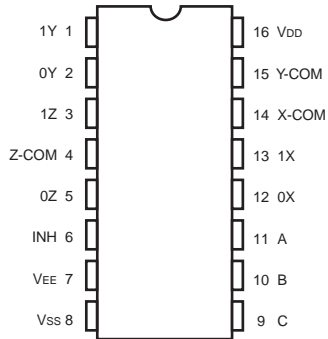

I/O C O/I	
Truth table	
CONTROL	Impedance Between
C	I/O O/I
H	$0.2 - 5 \times 10^2 \text{ ohm}$
L	$> 10^8 \text{ ohm}$

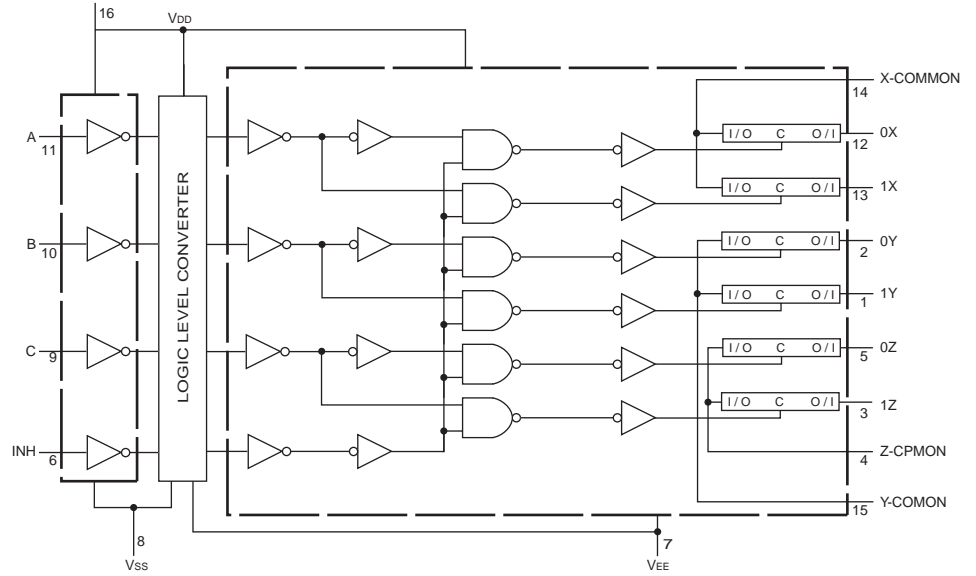

ICs BLOCK DIAGRAM / TERMINAL DESCRIPTION

Q401 - Q404 : NJM4565M
Operational amplifier

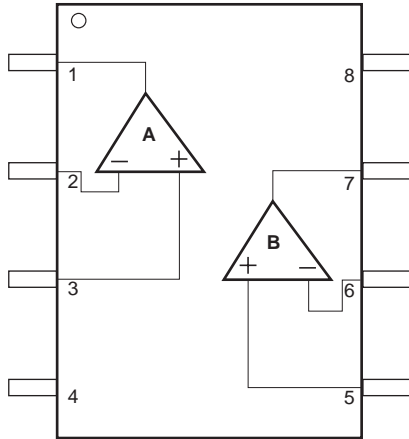

ICs BLOCK DIAGRAM / TERMINAL DESCRIPTION

Q602 : TC74HCT00AP
2-Input NAND gate

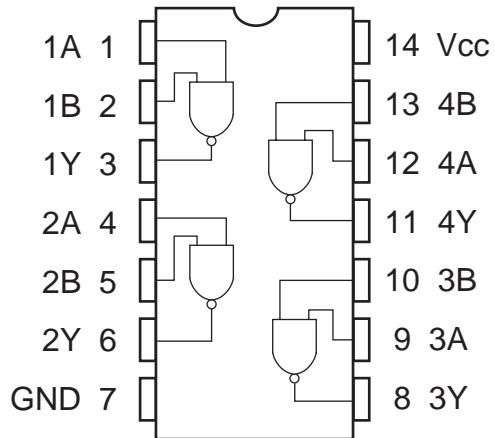

Truth table

A	B	Y
L	L	H
L	H	H
H	L	H
H	H	L

ICs BLOCK DIAGRAM / TERMINAL DESCRIPTION

Q352 : TC74VHCU04FT
Hex inverter

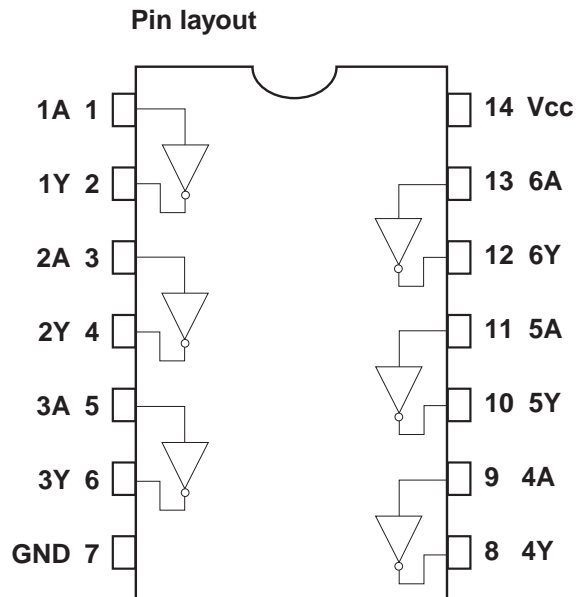

Truth table

A	Y
L	H
H	L

ICs BLOCK DIAGRAM / TERMINAL DESCRIPTION

IC881 : PM0026A Progressive Converter Except <MUP> model

Pin Layout

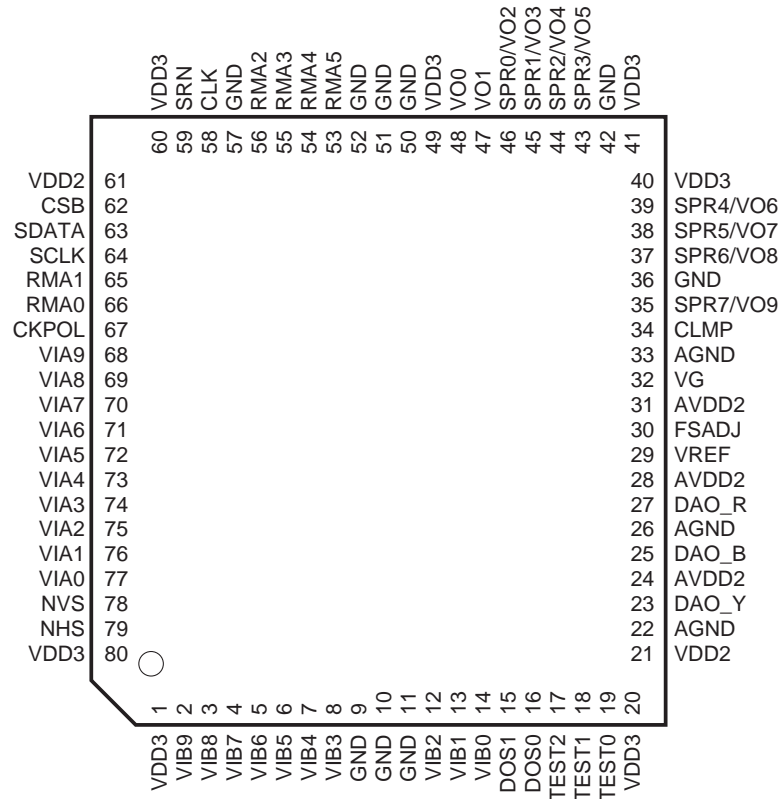

Block Diagram

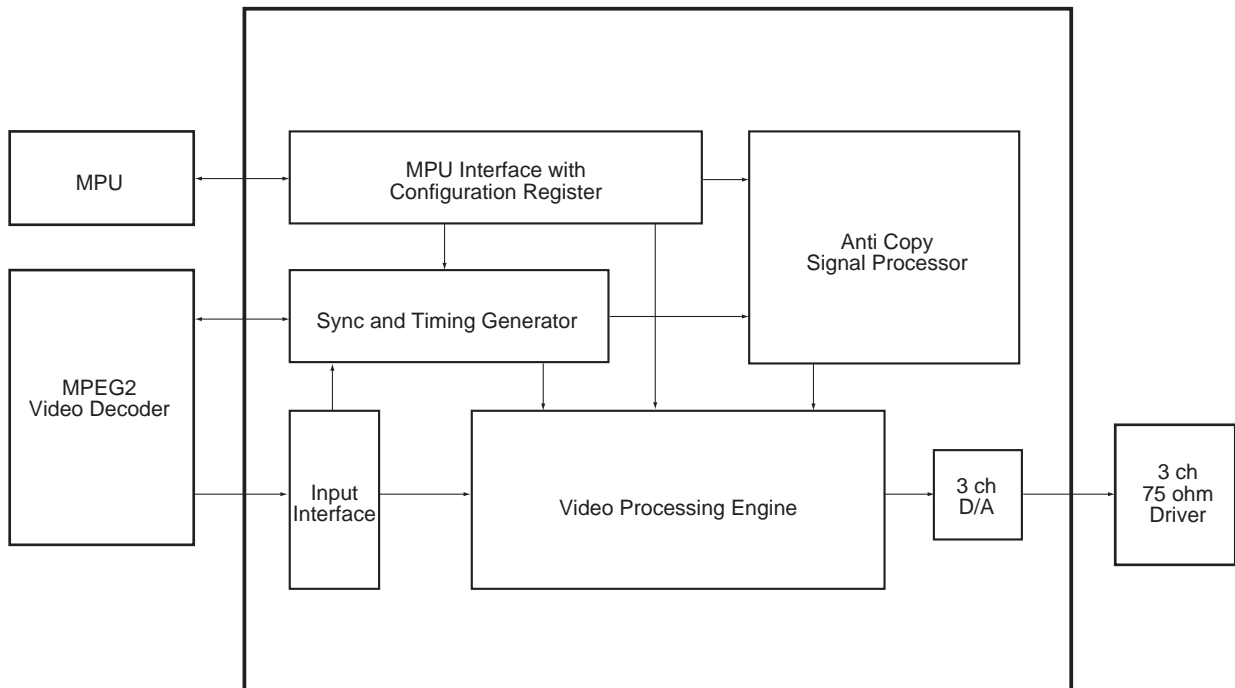

ICs BLOCK DIAGRAM / TERMINAL DESCRIPTION

Pin Function-1

No.	Pin Name	I/O	Pin Functio
1	VDD3	–	VDD (3.3V) for IO
2	VIB9	I	Video data B input (MSB)
3	VIB8		
4	VIB7		
5	VIB6		
6	VIB5		
7	VIB4		
8	VIB3		
9	GND	–	Digital ground
10	GND		
11	GND		
12	VIB2	I	Video data B input (LSB)
13	VIB1		
14	VIB0		
15	DOS1	I	Test input pins (ground)
16	DOS0		
17	TEST2		
18	TEST1		
19	TEST0		
20	VDD3	–	VDD (3.3V) for IO
21	VDD2	–	VDD (2.5V) for Core
22	AGND	–	Ground for DAC
23	DAO_Y	O	Analog video output (Y)
24	AVDD2	–	VDD (2.5V) for DAC
25	DAO_B	O	Analog video output (Cb)
26	AGND	–	Ground for DAC
27	DAO_R	O	Analog video output (Cr)
28	AVDD2	–	VDD (2.5V) for DAC
29	VREF	I	DAC reference voltage input
30	FSADJ	I/O	Resistor connection pin for maximum amplitude setting of DAC
31	AVDD2	–	VDD (2.5V) for DAC
32	VG	O	Reactance connection pin for gate voltage compensation of DAC current cell
33	AGND	–	Ground for DAC
34	CLMP	O	Clamp pulse output
35	SPR7/VO9	O	Serial and parallel conversion (MSB) / Video data output (MSB)
36	GND	–	Digital ground
37	SPR6/VO8	O	Serial and parallel conversion / Video data output
38	SPR5/VO7		
39	SPR4/VO6		
40	VDD3	–	VDD (3.3V) for IO

ICs BLOCK DIAGRAM / TERMINAL DESCRIPTION

Pin Function-2

No.	Pin Name	I/O	Pin Function
41	VDD3	–	VDD (3.3V) for IO
42	GND	–	Digital ground
43	SPR3/VO5	O	Serial and parallel conversion / video data output (LSB)
44	SPR2/VO4		
45	SPR1/VO3		
46	SPR0/VO2		
47	VO1		
48	VO0		
49	VDD3	–	VDD (3.3V) for IO
50	GND	–	Digital ground
51	GND		
52	GND		
53	RMA5	I	Resgister monitor address input (MSB)
54	RMA4		
55	RMA3		
56	RMA2		
57	GND	–	Digital ground
58	CLK	I	27 MHz system clock input
59	SRN	I	System reset input
60	VDD3	–	VDD (3.3V) for IO
61	VDD2	–	VDD (2.5V) for Core
62	CSB	I	Chip select input of MPU serial interface
63	SDATA	I	Data input of MPU serial interface
64	SCLK	I	Clock input of MPU serial interface
65	RMA1	I	Register monitor address input (LSB)
66	RMA0		
67	CKPOL	–	Polarity setting input of internal system clock
68	VIA9	I	Video data A input (MSB)
69	VIA8		
70	VIA7		
71	VIA6		
72	VIA5		
73	VIA4		
74	VIA3		
75	VIA2		
76	VIA1		
77	VIA0		
78	NVS	I/O	Vertical sync. input/output
79	NHS		Horizontal sync. input/output
80	VDD3	–	VDD (3.3V) for IO

ICs BLOCK DIAGRAM / TERMINAL DESCRIPTION

IC861 : ADV7172KST Video Encoder

Pin Layout

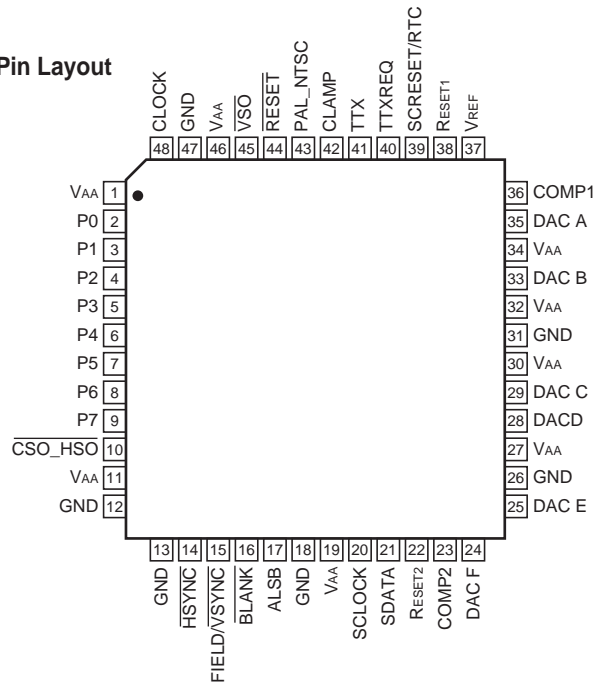

Block Diagram

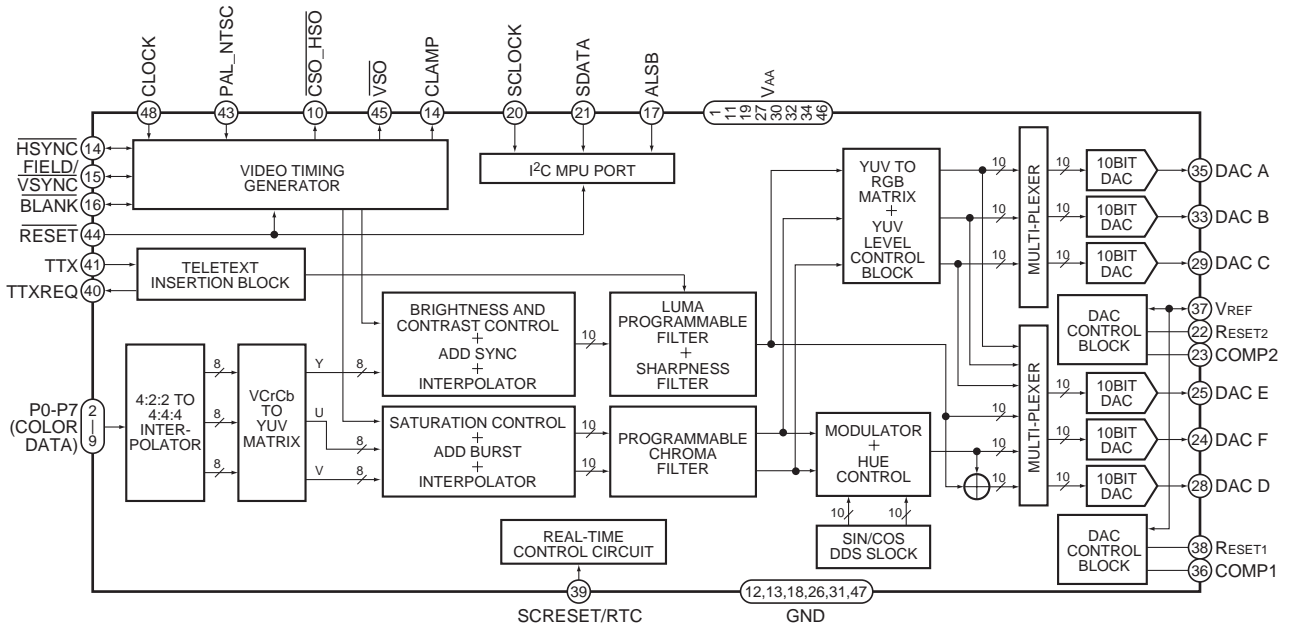

Pin Function

No.	Name	I/O	Pin Function
1	VAA	P	Power Supply (+3V) to +5V
2	P0	I	8-bit 4 : 2 : 2 Multiplexed YCrCb Pixel Port (P7-P0) P0 represents the LSB
3	P1		
4	P2		
5	P3		

ICs BLOCK DIAGRAM / TERMINAL DESCRIPTION

Pin Function

No.	Name	I/O	Pin Function
6	P4	I	8-bit 4 : 2 : 2 Multiplexed YCrCb Pixel Port (P7-P0) P0 represents the LSB
7	P5		
8	P6		
9	P7		
10	CSO_HSO	O	Dual function CSO or HSO TTL Output Sync Signal
11	VAA	P	Power Supply (+3V to +5V)
12	GND	G	Ground Pin
13	GND	G	Ground Pin
14	HSYNC	I/O	HSYNC (Models 1 and 2) Control Signal. This pin may be configured to output (Master Mode) or as an input and accept (Slave Mode) Sync signals.
15	FIELD/VSYNC	I/O	Dual Function FIELD (Mode1) and VSYNC (Mode2) Control Signal. This pin may be configured to output (Master Mode) or as an input (Slave Mode) and accept these control signals.
16	BLANK	I/O	Video Blanking Control Signal. The pixel inputs are ignored when this is logic level "0". This signal is optional.
17	ALSB	I	TTL Address Input. This signal sets up the LSB of the MPU address.
18	GND	G	Ground Pin
19	VAA	P	Power Supply (+3V to +5V)
20	SCLOCK	I	MPU Port Serial Interface Clock Input
21	SDATA	I/O	MPU Port Serial Data Input/Output
22	RSET2	I	A 600 ohm resistor connected from this pin to GND is used to control full-scale amplitudes of the Video Signals from DACs D, E and F (the "small" DACs).
23	COMP2	O	Compensation Pin for DACs D, E and F. Connect a 0.1mF Capacitor from COMP to VAA.
24	DAC F	O	RED/S-Video C/V Analog Output. This DAC is capable of providing 8.66 mA output.
25	DAC E	O	BLUE/S-Video Y/U Analog Output. This DAC is capable of providing 8.66 mA output.
26	GND	G	Ground Pin
27	VAA	P	Power Supply (+3V to +5V)
28	DAC D	O	GREEN/Composite/Y Analog Output. This DAC is capable of providing 8.66 mA output.
29	DAC C	O	RED/S-Video C/V Analog Output. This DAC is capable of providing 34.66 mA output.
30	VAA	P	Power Supply (+3V to +5V)
31	GND	G	Ground Pin
32	VAA	P	Power Supply (+3V to +5V)
33	DAC B	O	BLUE/S-Video Y/U Analog Output. This DAC is capable of providing 34.66 mA output.
34	VAA	P	Power Supply (+3V to +5V)
35	DAC A	O	GREEN/Composite/Y Analog Output. This DAC is capable of providing 34.66 mA output.
36	COMP1	O	Compensation Pin for DACs A, B and C. Connect a 0.1mF Capacitor from COMP to VAA. For Optimum Dynamic Performance in Low Power Mode, the value of the COMP1 capacitor can be lowered to as low as 2.2mF.
37	VREF	I/O	Voltage Reference Input for DACs or Voltage Reference Output (1.235V)
38	RSET1	I	A 150 ohm resistor connected from this pin to GND is used to control full-scale amplitudes of the Video Signals from DACs A, B and C (the "large" DACs).
39	SCRESET/RTC	I	This pin can be configured as an input by setting MR42 and MR41 of Mode Resistor 4. It can be configured as a subcarrier reset pin, in which case a high to low transition on this pin will reset the subcarrier phase to Field 0. Alternatively it may be configured as a Real-Time Control (RTCF) Input.
40	TTXREQ	O	Teletext Data Request input signal used to control teletext data transfer.
41	TTX	O	Teletext Data Input Pin.
42	CLAMP	O	TTL Output Signal to external circuitry to enable clamping of all video signals.
43	PAL_NTSC	I	Input signal to select PAL or NTSC mode of operation, pin set to Logic "1" selects PAL.
44	RESET	I	The input resets the on-chip timing generator and sets the ADV7172KST into default mode. This is NTSC operation, Timing Slave Mode 0, DACs A, B and C powered OFF, DACs D, E and F powered ON, Composite and S-Video out.
45	VSO	O	VSO TTL Output Sync Signal
46	VAA	P	Power Supply (+3V to +5V)
47	GND	G	Ground Pin
48	CLOCK	I	TTL Clock Input. Requires a stable 27 MHz reference clock for standard operation. Alternatively, a 24.52 MHz (NTSC) or 29.5 MHz (PAL) can be used for square pixel operation.

ICs BLOCK DIAGRAM / TERMINAL DESCRIPTION

IC807 : PD0274A Audio Quality Enhancer (AQE)

Pin Arrangement

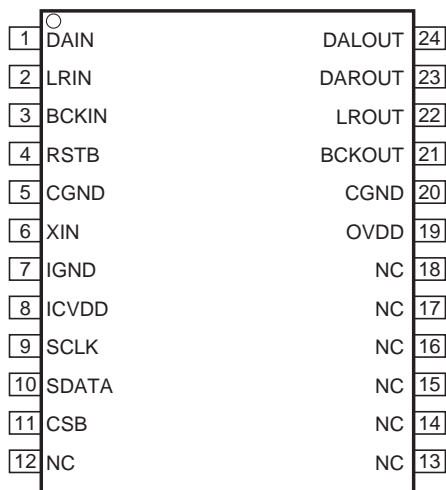

Block Diagram

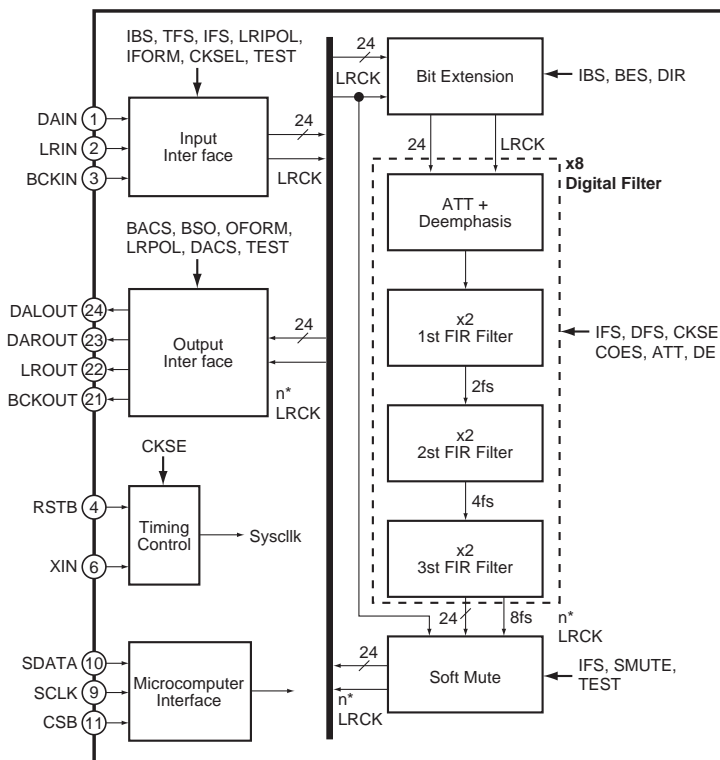

Note :
"n" in the Block diagram expresses the rate to sample

Pin Function

No.	Name	I/O	Pin Function
1	DAIN	I	Audio data input
2	LRIN	I	L/R clock input
3	BCKIN	I	Bit clock input (48fs/64fs)
4	RSTB	I	System reset "0" = Reset
5	CGND	—	Ground (0V) for Core
6	XIN	I	System clock input (128fs/192fs/256fs/384fs/512fs/768fs)
7	IGND	—	Ground (0V) for Input Buffer
8	ICVDD	—	Power supply (3.3V) for Core and Input Buffer
9	SCLK	I	Microcomputer interface clock input
10	SDATA	I	Microcomputer interface data input
11	CSB	I	Microcomputer interface chip select input "0" = Enable, "1" = Disenable
12	NC		No connection
13	NC		
14	NC		
15	NC		
16	NC		
17	NC		
18	OVDD	—	Power supply (3.3V) for Output Buffer
19	OGND	—	Ground (0V) for Output Buffer
20	CGND	—	Ground (0V) for Core
21	BCKOUT	O	Bit clock output (48fs/64fs)
22	LROUT	O	L/R clock output. WCLK output at PCM1704.
23	DAROUT	O	R ch audio data output
24	DALOUT	O	L ch audio data output or L/R ch multiplex output

ICs BLOCK DIAGRAM / TERMINAL DESCRIPTION

Q301 : PCM1742KE (Digital/ Analog signal converter)

Pin layout



Terminal Description

No.	Name	I/O	Pin Function
1	BCK	I	Audio data bit clock input
2	DATA	I	Audio data digital input
3	LRCK	I	L-channel and R-channel Audio data latch enable input
4	DGND	-	Digital ground
5	VDD	-	Digital power supply +3.3V
6	Vcc	-	Analog power supply +5V
7	VoutL	O	Analog output for L-channel
8	VoutR	O	Analog output for R-channel
9	AGND	-	Analog ground
10	VCOM	-	Common voltage decoupling
11	ZEROR/ZEROA	O	Zero flag output for R-channel / Zero flag output for L/R-channel
12	ZEROL/NA	O	Zero flag output for L-channel / No assign
13	MD	I	Mode control data input
14	MC	I	Mode control clock input
15	ML	I	Mode control latch input
16	SCK	I	System clock input

Block diagram

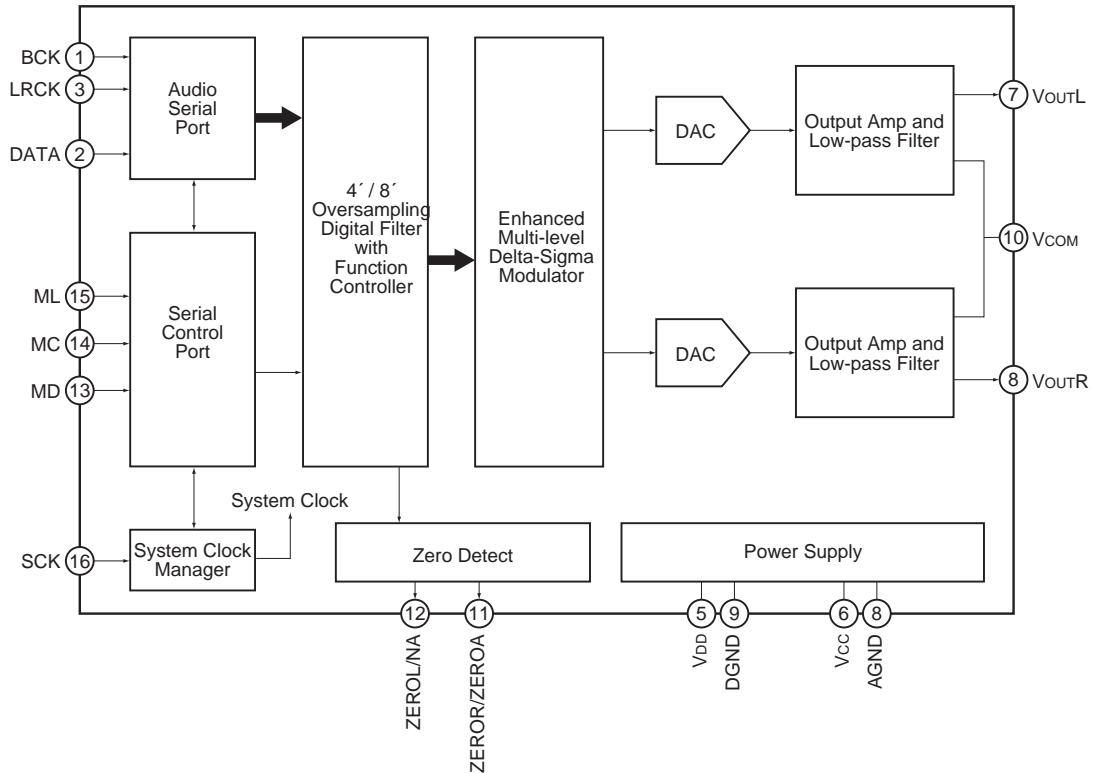

ICs BLOCK DIAGRAM / TERMINAL DESCRIPTION

IC801 : M65774BFP MPEG2 Decoder IC

Block Diagram

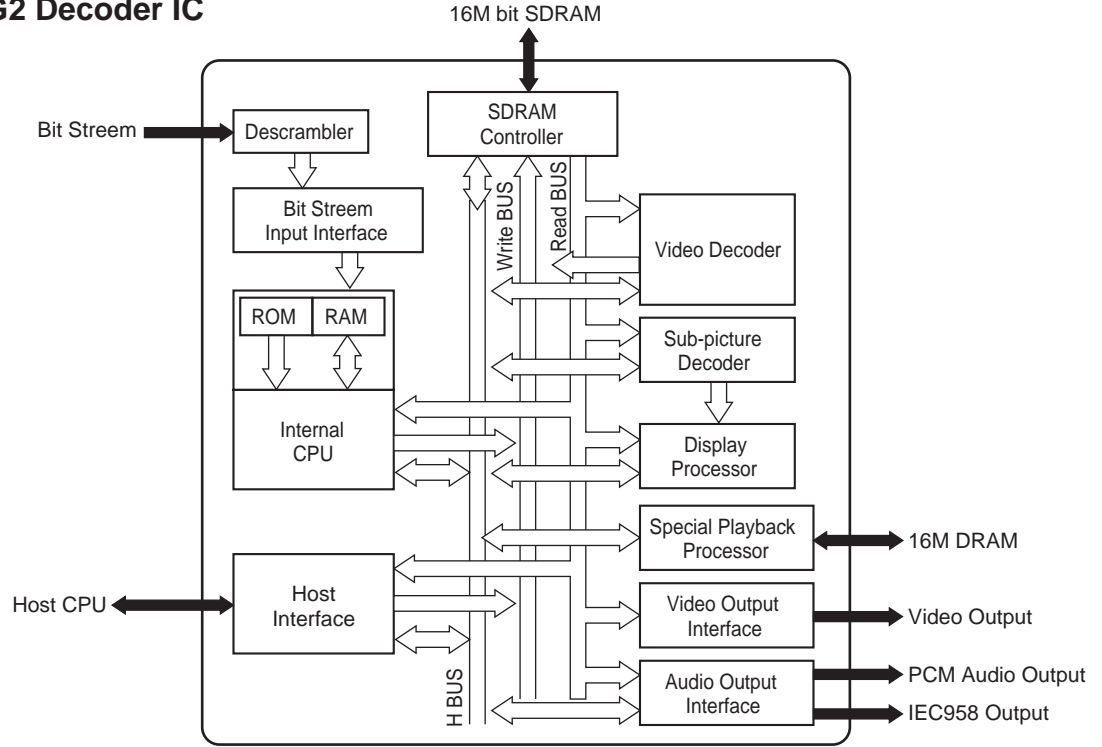

Pin Function-1

No.	Pin Name	I/O	Pin Function	No	Pin Name	I/O	Pin Function
1	GND		Ground	21	5VDD	I	5V power supply
2	HD0	I/O	Data input and output port	22	HD15	I/O	Data input and output port
3	HD1			23	CS	I	Chip select signal input
4	HD2			24	RE	I	Read Enable signal input
5	HD3			25	WE	I	Write Enable signal input
6	HD4			26	BHE	I	Byte High Enable signal input
7	5VDD	I	5V power supply	27	RYD	O	Acknowledge signal which is indicated the finish of data reading or writing via the host bus
8	VDD	I	Power supply	28	INTR	O	Interrupt request signal against to the external CPU from M65773FP
9	HD5	I/O	Data input and output	29	GND	I	Ground
10	HD6			30	HA0	I	Address input port
11	HD7			31	HA1		
12	HD8			32	HA2		
13	HD9			33	HA3		
14	GND	I	Ground	34	HA4		
15	HD10	I/O	Data input and out put port	35	VDD	I	Power supply
16	HD11			36	5VDD	I	5V power supply
17	HD12			37	HA5	I	Address input port
18	HD13			38	HA6		
19	HD14			39	HA7		
20	VDD	I	Power supply	40	HA8		

ICs BLOCK DIAGRAM/TERMINAL DESCRIPTION

Pin Function-2

No.	Pin Name	I/O	Pin Function	No.	Pin Name	I/O	Pin Function
41	HA9	I	Address input port	83	VDD	I	Power supply
42	GND	I	Ground	84	VSYNC	O	Vertical sync. signal output
43	CDMCK	I	Connect to ground	85	HSYNC	O	Horizontal sync. signal output
44	CDLRCK	I	L/R clock input from CDDSP	86	PICSTR		
45	CDBCK	I	PCM bit clock input from CDDSP	87	MBSTR		
46	CDDATA	I	Digital audio interface input	88	MBDAT		
47	VDD	I	Power supply	89	GND	I	Ground
48	CDDIN	I	PCM audio data input from CDDSP	90	PWD	O	Phase comparator output for external sync. operation
49	INT2	O	Interrupt request signal against to the external CPU from M65773FP	91	CSYNC	I	Composite SYNC signal input
50	INT3			92	OSDKEY	O	OSD key flag output
51	DREQ	O	DMA request signal for OSD bitmap transfer	93	XCL	O	Pixel clock (27MHz free-running clock)
52	DACK	I	DMA acknowledge signal for OSD bitmap transfer	94	VDD	I	Power supply
53	GND	I	Ground	95	PD7	O	Digital pixel data
54	CLKO	O	27MHz clock output	96	PD6		
55	CLKIN	I	System clock input	97	PD5		
56	AVDD1	I	Analog power supply	98	PD4		
57	AGND1	I	Analog ground	99	GND	I	Ground
58	AGND3			100	PD3	O	Digital pixel data
59	AVDD3	I	Analog power supply	101	PD2		
60	CCAP	I	Connect to ground	102	PD1		
61	AGND2	I	Analog ground	103	PD0		
62	AVDD2	I	Analog power supply	104	VDD	I	Power supply
63	ACLKO	–	Open	105	GND	I	Ground
64	ACLKI	I	Audio clock input	106	RESET	I	Hardware reset input
65	HMODE1	I	Setting pin of host interface operating mode	107	TEST0	I	Connect to ground normally
66	GND	I	Ground	108	TEST1		
67	VDD	I	Power supply	109	TEST2		
68	AOD	O	PCM output of audio data	110	VDD	I	Power supply
69	AO2			I/O	Data transfer line with DRAM		
70	AO1						
71	AO0						
72	GND	I	Ground	114	NMD14		
73	DOUT1	O	Digital audio interface output	115	GND	I	Ground
74	DOUT0			116	NMD2	I/O	Data transfer line with DRAM
75	SDA	–	Open	117	NMD13		
76	SCL	–	Open	118	NMD3		
77	VDD	I	Power supply	119	NMD12		
78	GND	I	Ground	120	VDD	I	Power supply
79	DACCLK	O	Over-sampling operating clock output	121	NMD4	I/O	Data transfer line with DRAM
80	DOCLK	O	PCM bit clock output	122	NMD11		
81	LRCLK	O	Clock output for discriminating the channel (L/R) of PCM audio data	123	NMD5		
82	HMODE0	I	Setting pin of host interface operating mode	124	NMD10		

ICs BLOCK DIAGRAM / TERMINAL DESCRIPTION

Pin Function-3

No.	Pin Name	I/O	Pin Function	No.	Pin Name	I/O	Pin Function	
125	GND	I	Ground	167	MA5	O	Address line with SDRAM	
126	NMD6	I/O	Data transfer line with DRAM		GND	I	Ground	
127	NMD9				169	MA1	O	Address line with SDRAM
128	NMD7				170	MA6		
129	NMD8				171	MA0		
130	VDD	I	Power supply	172	MA7			
131	NCAS0	O	CAS (Column Address Strobe) control line of DRAM	173	VDD	I	Power supply	
132	NWE	O	WE control of DRAM	174	MA10	O	Address line with SDRAM	
133	NOAS	O	CAS (Column Address Strobe) control line of DRAM	175	MA8			
134	NCAS1	O	RAS (Row Address Strobe) control line of DRAM	176	MA11			
135	GND	I	Ground	177	MA9			
136	NMA9	O	Address line with DRAM	178	GND	I	Ground	
137	NMA8				179	DCS	O	Chip select of SDRAM
138	VDD	I	Power supply	180	RAS	O	RAS (Row Address Strobe) control line of SDRAM	
139	NMA0	O	Address line with DRAM	181	CAS	O	CAS (Column Address Strobe) control line of SDRAM	
140	NMA7				182	VDD	I	Power supply
141	NMA1				183	MCLK		Operation clock of SDRAM
142	NMA6				184	GND	I	Ground
143	GND	I	Ground	185	DWE	O	WE control line of SDRAM	
144	NMA2	O	Address line with DRAM	186	DQMU	O	DQM control line of SDRAM Use for mask of upper byte output.	
145	NMA5				187	DQML	O	DQM control line of SDRAM Use for mask of lower byte output.
146	NMA3				188	VDD	I	Power supply
147	NMA4				189	MD7	I/O	Data transfer line with SDRAM
148	VDD	I	Power supply	190	MD8			
149	BD7	I	Bit stream input port	191	MD6			
150	BD6	I		192	MD9			
151	GND	I	Ground	193	GND	I	Ground	
152	BD5	I	Bit stream input port	194	MD5	I/O	Data transfer line with SDRAM	
153	BD4				195			MD1
154	BD3				196			MD
155	BD2				197			MD10
156	VDD	I	Power supply	198	VDD	I	Power supply	
157	GND	I	Ground	199	MD3	I/O	Data transfer line with SDRAM	
158	BD1	I	Bit stream input port	200	MD12			
159	BD0	I		201	MD2			
160	BCLK	I	Strobe signal (clock) of BD port	202	MD13			
161	BDEN	I	Indicates the effective or invalid data which is sampled from BD port	203	GND	I	Ground	
162	BDREQ	O	Output permission signal against to the device (channel decoder) which connecting to BD port	204	MD1	I/O	Data transfer line with SDRAM	
163	VDD	I	Power supply	205	MD14			
164	MA3	O	Address line with SDRAM	206	MD0			
165	MA4				207			MD15
166	MA2				208	VDD	I	Power supply

ICs BLOCK DIAGRAM / TERMINAL DESCRIPTION

IC201 : LC78652W Servo DSP IC

Block Diagram

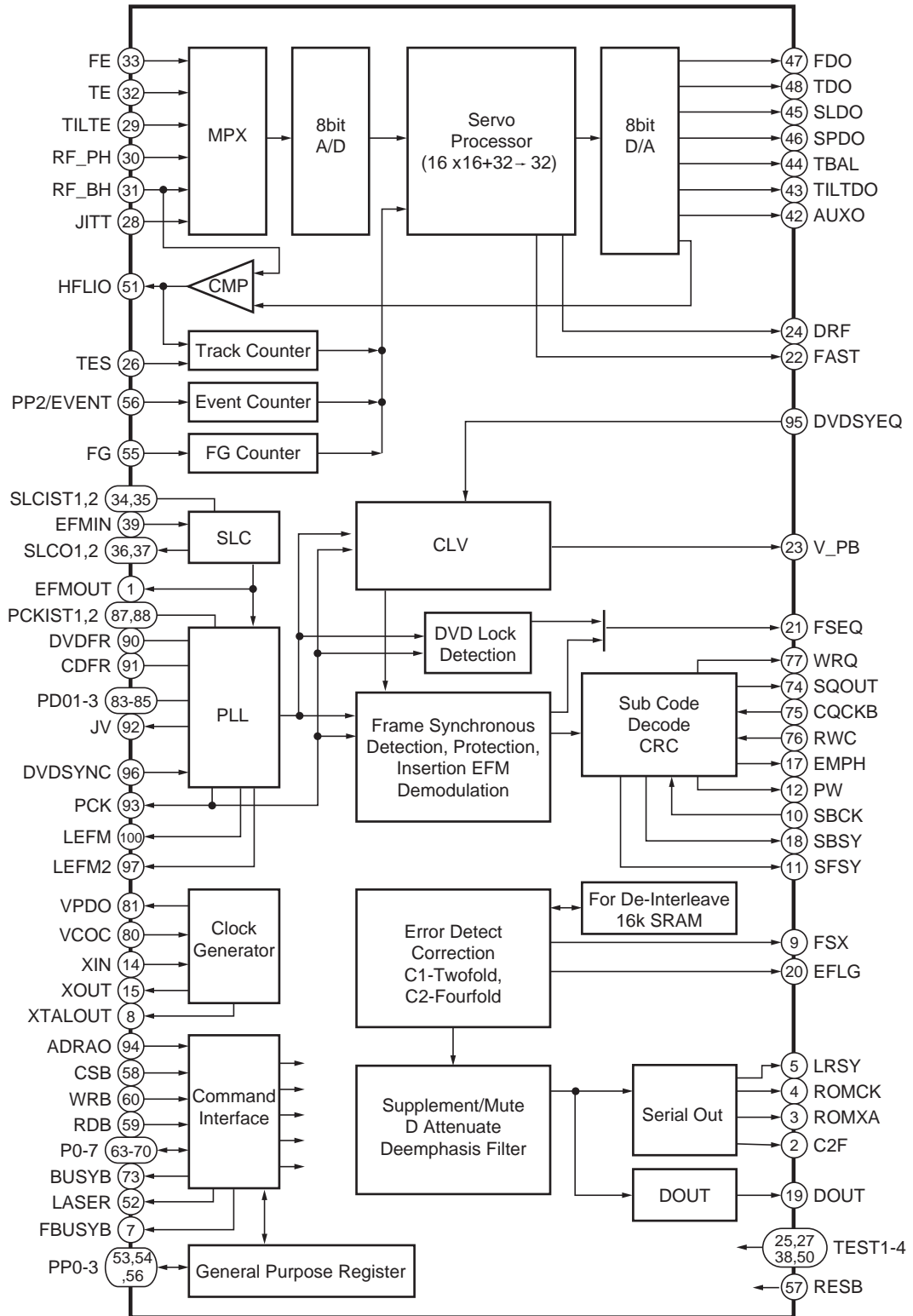

ICs BLOCK DIAGRAM / TERMINAL DESCRIPTION

LC78652W-2

Pin Function

No.	Pin Name	I/O	Pin Function
1	EFMOUT	O	Output the state that was binary-stated value EFM
2	C2F	O	C2 flag output
3	ROMXA	O	CD-ROM data output
4	ROMCK	O	Shift clock output for CD-ROM data output
5	LRSY	O	L/R clock output for CD-ROM data output
6	PP3	I/O	General-purpose port input/output / DVD sync. signal input N ch-OD output
7	FBUSYB	O	Busy signal output of DSP process operation N ch-OD output
8	XTALOUT	O	External system clock output
9	FSX	O	CD 1 frame sync. signal output
10	SBCK	I	Subcode reading out clock input
11	SFSY	O	Frame sync. signal output of subcode
12	PW	O	Subcode P, Q, R, S, T, U, V and W output
13	VSS	—	GND pin
14	XIN	I	Connect a crystal resonator (16.9344MHz)
15	XOUT	O	Connect a crystal resonator
16	DVDD1	—	3.3V power supply of the oscillation circuit
17	EMPH	O	Monitor pin of the deemphasis
18	SBSY	O	Sync. signal output of the subcode block
19	DOUT	O	Audio EIAJ data output
20	EFLG	O	Error correction state monitor of the error correction C1 and C2
21	FSEQ	O	Detection monitor of the CD/DVD frame sync. signal
22	FAST	O	Playback speed monitor N ch-OD output
23	V_PB	O	Monitor output of the rough servo/CLV control
24	DRF	O	In focus monitor
25	TEST3	I	Test input 3
26	TES	I	Tracking error signal input
27	TEST2	I	Test input 2
28	JITT	I	Jitter quantity detecting signal input of EFM PLL
29	TILTE	I	Tilt error signal input
30	RF_PH	I	RF peak hold signal input
31	RF_BH	I	RF bottom hold signal input
32	TE	I	Tracking error signal input
33	FE	I	Focus error signal input
34	SLCIST1	—	Current setting pin 1 of the constant current charge pump for SLC
35	SLCIST2	—	Current setting pin 2 of the constant current charge pump for SLC
36	SLCO1	O	Control output 1 for SLC
37	SLCO2	O	Control output 2 for SLC
38	TEST1	I	Test input 1
39	EFMIN	I	EFM/EFM + input
40	AVDD	—	5V power supply of A/D and D/A for servo
41	AVSS	—	GND of A/D and D/A for servo
42	AUXO	O	DA auxiliary output
43	TILTDO	O	Tilt control signal output
44	TBAL	O	Tracking balance control signal output
45	SLDO	O	Sled control signal output
46	SPDO	O	Spindle control signal output
47	FDO	O	Focus control signal output
48	TDO	O	Tracking control signal output
49	VREF	—	Reference level of D/A for servo
50	TEST4	I	Test input 4

ICs BLOCK DIAGRAM / TERMINAL DESCRIPTION

LC78652W-3

No.	Pin Name	I/O	Pin Function
51	FLIO	I/O	Mirror detection signals input/output
52	LASER	O	Output pin for laser ON/OFF control
53	PP0/DVD CDB	I/O	General-purpose port input/output / Disc discrimination signal output
54	PP1/CRCERRB	I/O	General-purpose port input/output / Subcode CRC result signal output
55	FG	I	FG counter input
56	PP2/EVENT	I/O	General-purpose port input/output / Event counter input
57	RESB	I	Reset input
58	CSB	I	Chip select input
59	RDB	I	Internal state reading signal input
60	WRB	I	Command / data writing signal input
61	DVDD2	—	5V power supply
62	VSS	—	GND
63	P0	I/O	Command / data input/output
64	P1		
65	P2		
66	P3		
67	P4		
68	P5		
69	P6		
70	P7		
71	VSS	—	GND
72	DVDD1	—	3.3V power supply for internal
73	BUSYB	O	Busy signal output of command process
74	SQOUT	O	Serial output of subcode Q
75	CQCKB	I	Shift clock input for subcode Q data output
76	RWC	I	Update permission input of subcode Q
77	WRQ	O	Read out ready monitor of subcode Q
78	AVSS	—	PLL GND for internal system clock
79	VRPFR	—	VCO oscillation range setting of PLL for system clock
80	VCOC	I	Connect a PLL filter for system clock
81	VPDO	O	
82	AVDD	—	PLL 5V power supply for system clock
83	PDO1	I/O	PLL filter connection pin 1 for EFM playback
84	PDO2	I/O	PLL filter connection pin 2 for EFM playback
85	PDO3	I/O	PLL filter connection pin 3 for EFM playback
86	AVSS	—	PLL GND for EFM playback
87	PCKIST1	—	Current setting 1 of PLL constant current charge pump for EFM playback
88	PCKIST2	—	Current setting 2 of PLL constant current charge pump for EFM playback
89	AVDD	—	PLL 5V power supply for EFM playback
90	DVDFR	—	VCO oscillation range setting of PLL for EFM playback 1
91	CDFR	—	VCO oscillation range setting of PLL for EFM playback 2
92	JV	O	Jitter output of PLL clock for EFM playback
93	PCK	O	Bit clock output for EFM playback
94	ADRAO	I	Address input
95	DVDSYEQ	I	DVD synchronize pulse input
96	DVDSYNC	I	DVD synchronous signal input
97	LEFM2	O	Output the state that cut and out a signal which was binary-stated value EFM with PCK 2
98	DVDD1	—	3.3V power supply for I/O
99	VSS	—	GND
100	LEFM	O	Output the state that cut and out a signal which was binary-stated value EFM with PCK 1

ICs BLOCK DIAGRAM / TERMINAL DESCRIPTION

IC101 : LA9701M RF Amplifier

Block Diagram

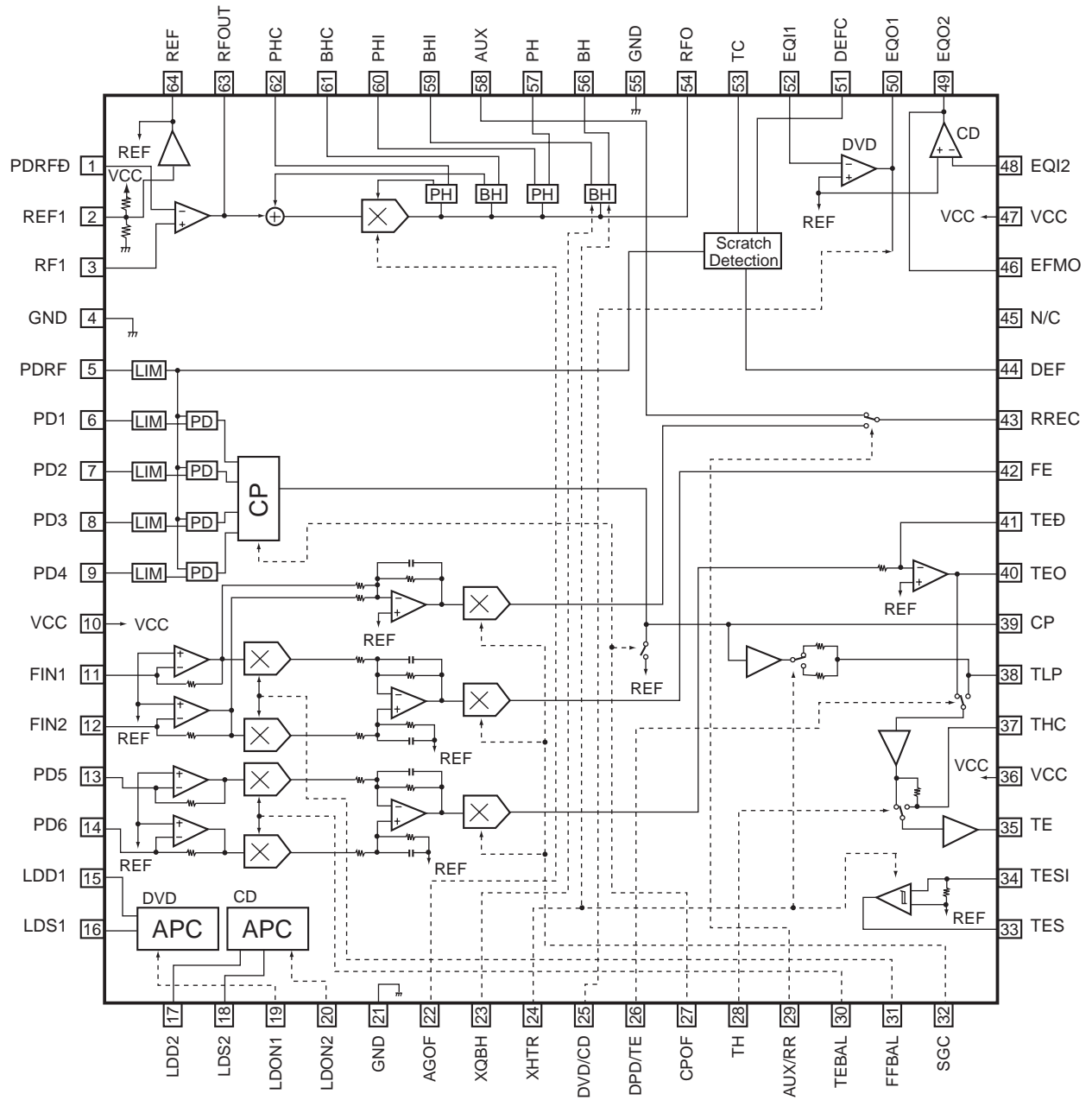

ICs BLOCK DIAGRAM/ TERMINAL DESCRIPTION

Q207 : LA73054 (6-CHANNEL VIDEO DRIVER)

Block Diagram

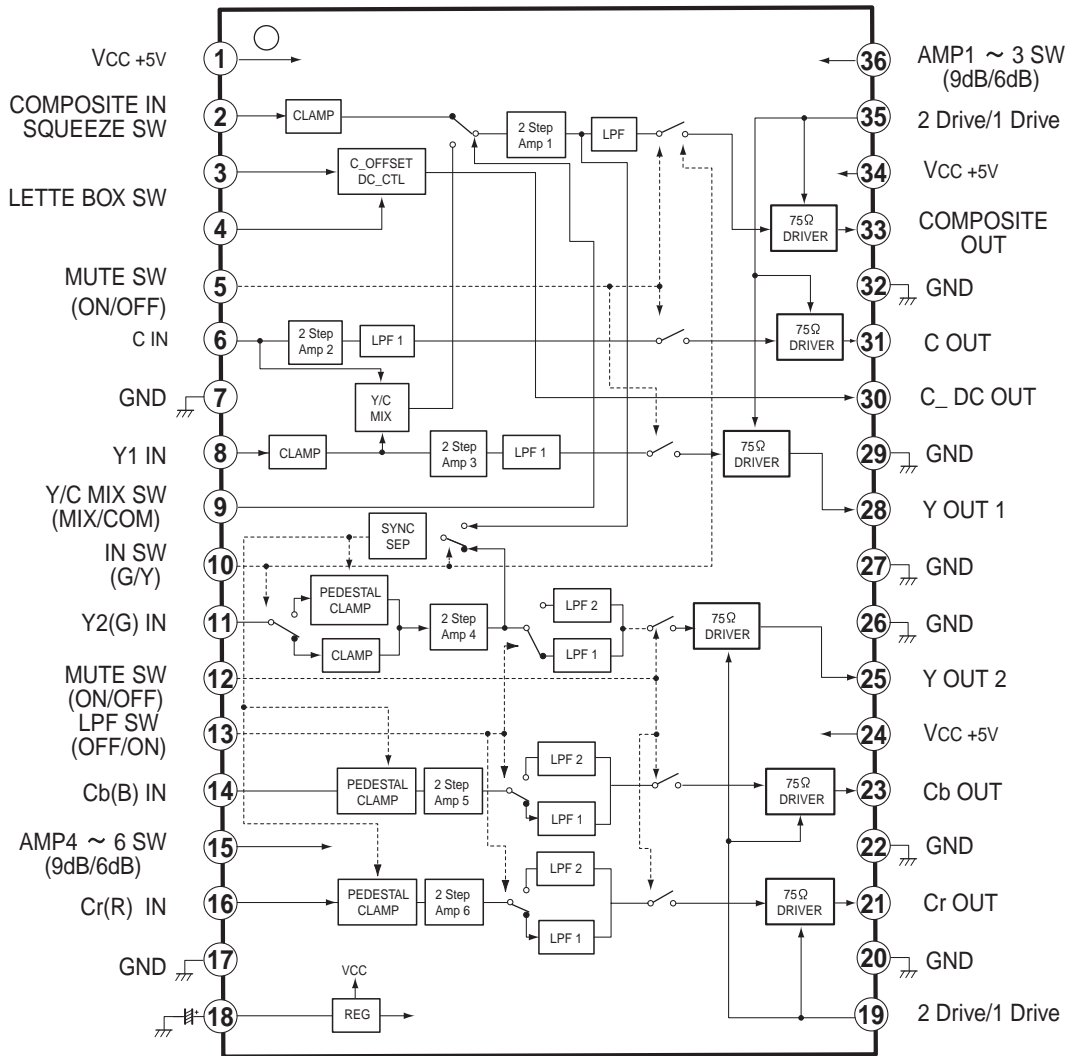

ICs BLOCK DIAGRAM / TERMINAL DESCRIPTION

IC251 : BA6664FM Three-phase Motor Driver

Block Diagram

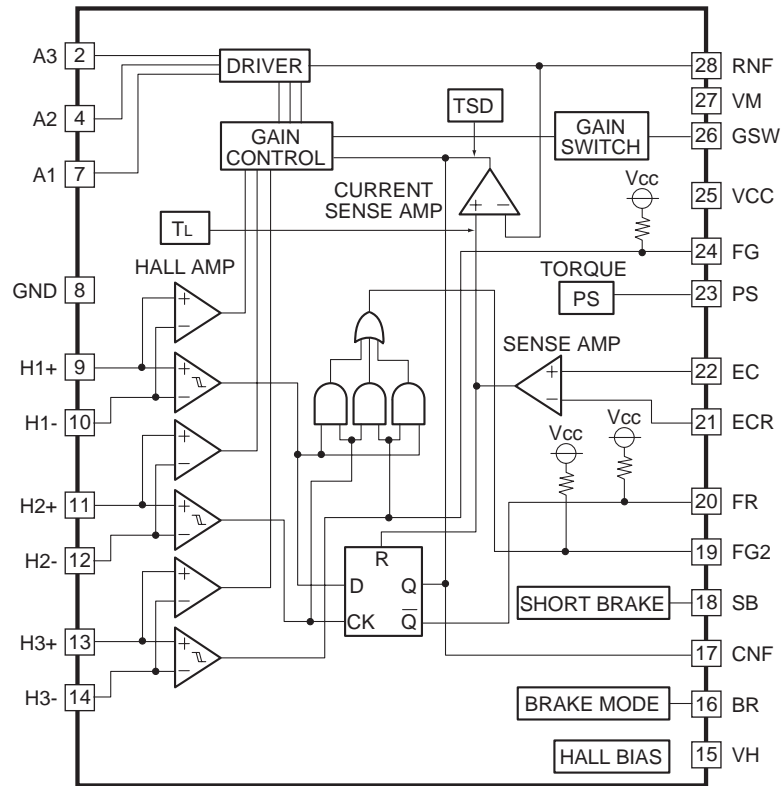

Block Diagram

No.	Pin Name	Pin Function	No.	Pin Name	Pin Function
1	N.C.	N.C.	16	BR	Brake mode switching pin
2	A3	Output pin	17	CNF	Capacitor connection pin for phase compensation
3	N.C.	N.C.	18	SB	Short brake pin
4	A2	Output pin	19	FG2	FG 3-phase mix signal output pin
5	N.C.	N.C.	20	FR	Rotation detecting pin
6	N.C.	N.C.	21	ECR	Control reference pin of output voltage
7	A1	Output pin	22	EC	Output voltage control pin
8	GND	GND pin	23	PS	Power save pin
9	H1+	Hall signal input pins	24	FG	FG signal output pin
10	H1-		25	VCC	Power supply pin
11	H2+		26	GSW	Gain switching pin
12	H2-		27	VM	Motor power pin
13	H3+		28	RNF	Resistor connection pin for output current detection
14	H3-		FIN	FIN	GND
15	VH	Hall bias pin			

ICs BLOCK DIAGRAM / TERMINAL DESCRIPTION

IC601 : PD6345A FR CPU

Pin Function-1

No.	Mark	Pin Name	I/O	Pin Function
1	P20/D16	D0	I/O	Data bus input/output
2	P21/D17	D1		
3	P22/D18	D2		
4	P23/D19	D3		
5	P24/D20	D4		
6	P25/D21	D5		
7	P26/D22	D6		
8	P27/D23	D7		
9	P30/D24	D8		
10	P31/D25	D9		
11	P32/D26	D10		
12	P33/D27	D11		
13	P34/D28	D12		
14	P35/D29	D13		
15	P36/D30	D14		
16	P37/D31	D15		
17	VSS	GND		Ground
18	P40/A00	A0	O	Address bus output
19	P41/A01	A1		
20	P42/A02	A2		
21	P43/A03	A3		
22	P44/A04	A4		
23	P45/A05	A5		
24	P46/A06	A6		
25	P47/A07	A7		
26	VCC3	V+3.3D		Power supply
27	VCC2	V+2.5D		Power supply
28	P50/A08	A8	O	Address bus output
29	P51/A09	A9		
30	P52/A10	A10		
31	P53/A11	A11		
32	P54/A12	A12		
33	P55/A13	A13		
34	P56/A14	A14		
35	P57/A15	A15		
36	VSS	GND		Ground
37	P60/A16	A16	O	Address bus output
38	P61/A17	A17		
39	P62/A18	A18		
40	P63/A19	A19		
41	P64/A20	A20		
42	P65/A21	TOFSTA	O	Tracking offset injection -A for servo
43	P66/A22	TOFSTC	O	Tracking offset injection -C for servo
44	P67/A23	WBL	O	For Wobble detection corresponding to DVD R/W (main)
45	DAVS	GND		Ground
46	DAVC	V+3.3D		Power supply
47	DA0	STEP1	I	For stepping motor control
48	DA1	STEP2	I	
49	DA2	LODRV	I	Loading, door and select motor drive

ICs BLOCK DIAGRAM / TERMINAL DESCRIPTION

Pin Function-2

No.	Mark	Pin Name	I/O	Pin Function
50	AN0	STEP2	I	For stepper control 2 For offset cancel of D/A output
51	AN1	STEP1	I	For stepper control 1 For offset cancel of D/A output
52	AN2	NAP SW	I	Rear panel H/M/L=M/A/P
53	AN3	XOEM	I	OEM model protection input
54	AN4	LD CUR	I	Input for LD current value indication
55	AN5	SELPOS	I	Tray selector input of microchanger
56	AN6	CLAMPS	I	Clamp position SW input
57	AN7	LODPOS	I	Loading clamp position SW input
58	AVCC	V+3.3D	—	Power supply
59	AVRH	V+3.3D	—	Power supply
60	AVSS/AVRI	GND	—	Ground
61	VSS	GND	—	Ground
62	PP0/ATGX	SLDPOS	I	SW input of slider inside position
63	PP1/FRCK	GSW	O	Gain up at ACBR (at ACBR: H, others: L)
64	PP2/IN0	780ON	I	ON/OFF control signal of 780nm laser diode
65	PP3/IN1	SEDO	O	Tray rotation drive output
66	PP4/IN2	XMON	O	Mute of DRV (spindle motor ON: H)
67	PP5/IN3	XDRVMUT	O	FTS driver mute output
68	PP6	LT1	O	Communication response to the FL controller
69	PP7	XRDY	I	Communication request from the FL controller
70	VCC3	V+3.3D	—	Power supply
71	VCC2	V+2.5D	—	Power supply
72	PO0/OC0	XCURDET	I	Actuator current detection input Servo OFF for "L" 300ms
73	PO1/OC1	XCBUSY	I	Busy signal of command process Command acceptable : "L"
74	PO2/OC2	DSVRT		Servo DSP reset
75	PO3/OC3	BCA		BCA read signal (at BCA read: H) (Not used)
76	PO4/OC4	DSCSNS/ XCD4X	I/O	Disc detection pulse "L": Disc exist Correspond to fourth speed CD playback ("L": Fourth speed)
77	PO5/OC5	PPCNT	O	Switch of TZC in WBL traversal (at PP: H)
78	PO6/OC6	XDFINH	O	Defect signal control (DEFECT ON: Hi-Z; OFF: "L")
79	PO7/OC7	DPD/TE	O	H=1 beam, L=3 beams
80	VSS	GND	—	Ground
81	PN0/AIN0	DVD/XCD	O	RF EQ switching signal at DVD/CD "H": DVD, "L": CD
82	PN1/BIN0	AGOFF	O	"H": Turn off AGC of RFIC
83	PN2/AIN1	650X780	O	780nm/650nm switching signal
84	PN3/BIN1	LD ON	O	ON/OFF control signal of laser diode
85	PN4/AIN2	FOFST2	O	Focus offset adjustment 1 (Tri-value control "H", "L", Hi-Z)
86	PN5/BIN2	FOFST1	O	Focus offset adjustment 2 (Tri-value control "H", "L", Hi-Z)
87	PN6/AIN3	XCD2X	O	For VCD double speed playback
88	PN7/BIN3	OEICG	O	"H": Gain of OEIC up to 6dB
89	PM0/ZIN0	TRYPOS	I	Count input of disc number
90	PM1/ZIN1	N/XP SW	O	Video encoder control port (NTSC/PAL)
91	PM2/ZIN2	V SEL	O	(Composite, S) / (YCbCr) or (RGB) switch
92	PM3/ZIN3	V SEL2	O	(Composite) of skirt terminal / (S) switch
93	PL0/SDA1	SDAI		12C control lines
94	PL1/SDA0	SDAO		
95	PL2/SCL1	SCLI		
96	PL3/SCL0	SCLO		
97	PL4	CTS	I	RS-232C clear to send input
98	PL5	DTR	O	RS-232C clear to send output
99	PL6/UC0	-	—	
100	VSS	GND	—	Ground

ICs BLOCK DIAGRAM / TERMINAL DESCRIPTION

Pin Function-3

No.	Mark	Pin Name	I/O	Pin Function
101	PK0/TIN0	XVQEST	O	VQE3 reset signal
102	PK1/TIN1	XCSPR 1	–	Serial communication enable of the progressive converter IC
103	PK2/TIN2	XCSVQ5	–	Serial communication enable of VQE5 IC
104	PK3/TIN3	N.C.	–	N.C.
105	PK4/TOT0	44X48	O	DAC and DASP supply clock fs 44/48 selection
106	PK5/TOT1	DI ERR	I	DIR reception error (unlock signal) input
107	PK6/TOT2	XMICON2 AOSEL1	O	Mic center MIX signal for multi CH AV-1/audio DSP switch (front L/R data)
108	PK7/TOT3	AOSEL0	–	AV1 output AOD and AO0 switch
109	VCC3	V+3.3D	–	Power supply
110	VCC2	V+2.5D	–	Power supply
111	PJ0/INT0	XINT0	I	
112	PJ1/INT1	XINT1	I	
113	PJ2/INT2	XIRQ10	I	MY chip interrupt #0
114	PJ3/INT3	XIRQ11	I	MY chip interrupt #1
115	PJ4/INT4	XABUSY	I	Busy signal of DSP process operation "L"
116	PJ5/INT5	THLD	I	Playback speed monitoring signal
117	PJ6/INT6	SBSY	I	Sync. signal of subcode block (period SO+SI "H")
118	PJ7/INT7	N.C.	I	N.C.
119	PI0/SI0	SSI	I	Serial bus data input
120	PI1/SO0	SSO	O	Serial bus data output
121	PI2/SCK0	SSCK	I	Serial bus clock input
122	PI3/SI1	RXD	I	RS-232C RXD
123	PI4/SO1	TXD	O	RS-232C TXD
124	PI5/SCK1	SELMOD	–	Audio DSP mode switch
125	PH0/SI2	RESET2	O	Reset for DSP 2
126	PH1/SO2	XCSAD 1P	O	CS for DSP 2
127	PH2/SCK2	XCSSPD	–	Latch signal of serial/parallel IC for generating audio DSP control signal
128	MD0	GND	–	Ground
129	MD1	GND	–	
130	MD2	GND	–	
131	VSS	GND	–	Ground
132	VCC2	V+2.5D	–	Power supply
133	VSS	GND	–	Ground
134	X1	EXTAL	O	
135	X0	XTAL	I	
136	VCC3	V+3.3D	–	Power supply
137	PC0/DREQ2	LFEON RESET1	O	Select Mix to front L/R of LFE element DSP 1 reset
138	PC1/DACK2	XMICON1 AV1/XSDSP	O	Mic front L/R MIX signal for 2 ch AV-1/servo DSP switch
139	PC2/DEOP2	6CHMD	O	DAC output 2 ch/6 ch switch (– XDVRST2)
140	PB0/DREQ0	XDREQ0	I	DMA response output to BY Chip
141	PB1/DACK0	DACK0	O	DMA request input from BY Chip
142	PB2/DEOP0	N.C.	–	N.C.
143	PB3/DREQ1	XDREQ1	I	DMA response output to AV-1 Chip
144	PB4/DACK1	XDACK1	O	DMA request input from AV-1 Chip
145	PB5/DEOP1	XEXCKON	O	ON/OFF switch of DSP external clock
146	PB6/IOWRX	DOISEL1	O	Digital output switch 1 of audio DSP (AV-1. DSP and GND)
147	PB7/IORDX	DOISEL2	O	Digital output switch 2 of audio DSP (AV-1. DSP and GND)
148	VSS	GND	–	Ground
149	PA0/CSOX	XCS20	O	Chip select output to Flash ROM
150	PA1/CS1X	XCS6	O	AV-1 Chip select

ICs BLOCK DIAGRAM / TERMINAL DESCRIPTION

Pin Function-4

No.	Mark	Pin Name	I/O	Pin Function
151	PA2/CS2X	XCS3	O	Chip select of PD4995A (MY Chip)
152	PA3/CS3X	XCS4	O	Chip select of servo DSP
153	PA4/CS4X	XCS23	O	Chip select output to SRAM (1M)
154	PA5/CS5X	N.C.	O	N.C.
155	PA6/CS6X	N.C.	O	N.C.
156	PA7/CS7X	N.C.	O	N.C.
157	VCC3	V+3.3D	–	Power supply
158	VCC2	V+2.5D	–	Power supply
159	NMIX	-	–	V+3.3D fixed
160	HSTX	-	–	V+2.5D fixed
161	INITX	XINIT	I	
162	P80/RDY	RDY	I	
163	P81/BGRNTX	XAMUTE	I	Final stage mute of 2 ch audio output
164	P82/BRQ	XMMUTE	O	Audio multi channel mute
165	P83/RDX	XRD	O	
166	P84/WR0X	XWR0	O	
167	P85/WR1X	XWR1	O	
168	VSS	GND	–	Ground
169	P90/SYSCLK	SYSCLK	O	
170	P91	DFRST	–	DAC reset (for front L/R)
171	P92/MCLK	DFRST1	–	DAC reset (for center, surround and LFE)
172	P93	XCSDf0	O	DAC chip select (←XLAT3)
173	P94/LBAX	XCSDf1	O	DAC chip select for center, surround and LFE
174	P95/BAAX	XAQRST	O	AQE reset
175	P96	XCSAQE	O	AQE chip select
176	P97/WEX	TM ENT	I	Test mode entry