

ONKYO SERVICE MANUAL

DVD PLAYER MODEL DV-SP501

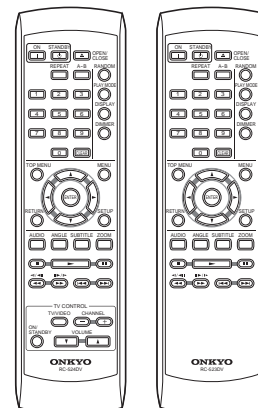
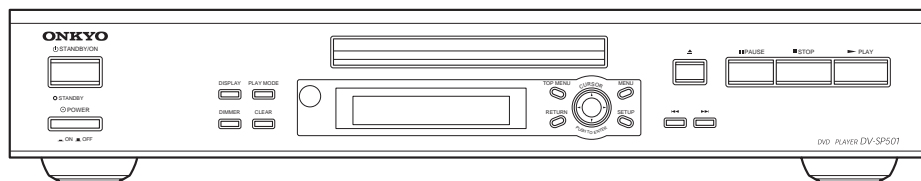

RC-524DV North American model
RC-523DV Other models

Black, Silver and Golden models

BMDD1N, BMDC1N	120V AC, 60Hz
BMUP2P, SMUP2P	230-240V AC, 50Hz
BMUS4P, BMUT3P, GMUK3P, GMUR6P, GMUT3P, SMUS4P	110-240V AC, 50/60Hz

SAFETY-RELATED COMPONENT WARNING!!

COMPONENTS IDENTIFIED BY MARK  ON THE SCHEMATIC DIAGRAM AND IN THE PARTS LIST ARE CRITICAL FOR RISK OF FIRE AND ELECTRIC SHOCK. REPLACE THESE COMPONENTS WITH ONKYO PARTS WHOSE PART NUMBERS APPEAR AS SHOWN IN THIS MANUAL.

MAKE LEAKAGE-CURRENT OR RESISTANCE MEASUREMENTS TO DETERMINE THAT EXPOSED PARTS ARE ACCEPTABLY INSULATED FROM THE SUPPLY CIRCUIT BEFORE RETURNING THE APPLIANCE TO THE CUSTOMER.

SPECIFICATIONS

Video system		North American model: Standard NTSC Other models: PAL/AUTO
Region code		North American model: 1, European model: 2, Australian and South American models: 4, Asian model: 3, Chinese model: 6
Laser		Semiconductor laser, wavelength 650 nm (DVD), 780 nm (CD)
Frequency response	DVD linear audio	4 Hz±20 kHz @ 48 kHz sampling rate 4 Hz±44 kHz @ 96 kHz sampling rate
	CD audio	4 Hz±20 kHz
Signal-to-noise ratio (digital audio)		106 dB
Audio dynamic range (digital audio)		96 dB
Harmonic distortion (digital audio)		0.008%
Wow and Futter		Below measurable level (±0.001% (W. PEAK) or less)
Operating conditions	Temperature	5° to 35° C (41° F to 95° F)
	Installation	Install horizontally
Video outputs	COMPONENT VIDEO (Other than European models)	Y: 1.0 V (p-p), 75 ohm, negative sync, RCA/phono x1 P _B /P _R : 0.7 V (p-p), 75 ohm
	AV CONNECTOR (European model only)	0.7 V (p-p), 75 ohm, Scart x1
	S VIDEO (S-Video)	Y: 1.0 V (p-p), 75 ohm, negative sync, 4-pin mini DIN x1 C: 0.286 V (p-p), 75 ohm
	VIDEO (composite video)	1.0 V (p-p), 75 ohm, negative sync, RCA/phono x1
Audio outputs	OPTICAL	-22.5 dBm, optical connector x1
	COAXIAL	0.5 V (p-p), 75 ohm, RCA/phono x1
	ANALOG	2.0 V rms, 470 Ω, RCA/phono x1
General	Power supply	North American model: 120 V AC, 60 Hz Other models: 100 - 240 V AC, 50/60 Hz
	Power consumption	15 W
	Power consumption in Standby mode	North American model: 1.6 W Other models: 2.5 W
	Weight	3.3 kg (7.3 lbs.)
Dimensions (W x H x D)		435 X 81 X 307 mm (17-1/8" X 3-3/16" X 12-1/16")

Specifications and features subject to change without notice.

SERVICE PROCEDURES-1

PROTECTION OF EYES FROM LASER BEAM DURING SERVICING

This set employs a laser. Therefore, be sure to follow carefully the instructions below when servicing.

WARNING!!

SERVICE WARNING : DO NOT APPROACH THE LASER EXIT WITH THE EYE TOO CLOSELY. IN CASE IT IS NECESSARY TO CONFIRM LASER BEAM EMISSION, BE SURE TO OBSERVE FROM A DISTANCE OF MORE THAN 30cm FROM THE SURFACE OF THE OBJECTIVE LENS ON THE OPTICAL PICKUP BLOCK.

Laser Diode Properties

Wavelength: 650/780nm (DVD/CD)

WARNING

WARNING:

TO REDUCE THE RISK OF FIRE OR ELECTRIC SHOCK, DO NOT EXPOSE THIS APPLIANCE TO RAIN OR MOISTURE.

CAUTION:

TO REDUCE THE RISK OF ELECTRIC SHOCK, DO NOT REMOVE COVER (OR BACK). NO USER-SERVICEABLE PARTS INSIDE. REFER SERVICING TO QUALIFIED SERVICE PERSONNEL.



WARNING
RISK OF ELECTRIC SHOCK
DO NOT OPEN

AVIS
RISQUE DE CHOC ELECTRIQUE
NE PAS OUVRIR



The lightning flash with arrowhead symbol, within an equilateral triangle, is intended to alert the user to the presence of uninsulated "dangerous voltage" within the product's enclosure that may be of sufficient magnitude to constitute a risk of electric shock to persons.



The exclamation point within an equilateral triangle is intended to alert the user to the presence of important operating and maintenance (servicing) instructions in the literature accompanying the appliance.

LASER WARNING

This unit contains a semiconductor laser system and is classified as a "CLASS 1 LASER PRODUCT". So, to use this model properly, read this Instruction Manual carefully. In case of any trouble, please contact the store where you purchased the unit. To prevent being exposed to the laser beam, do not try to open the enclosure.

CAUTION:

VISIBLE LASER RADIATION WHEN OPEN AND INTERLOCK FAILED OR DEFEATED. DO NOT STARE INTO BEAM.

CAUTION:

THIS PRODUCT UTILIZES A LASER. USE OF CONTROLS OR ADJUSTMENTS OR PERFORMANCE OF PROCEDURES OTHER THAN THOSE SPECIFIED HEREIN MAY RESULT IN HAZARDOUS RADIATION EXPOSURE.

The label on the right is applied on the rear panel except for USA and Canadian models.



1. This unit is a CLASS 1 LASER PRODUCT and employs a laser inside the cabinet.
2. To prevent the laser from being exposed, do not remove the cover. Refer servicing to qualified personnel.

SERVICE PROCEDURE

1. Replacing the fuses

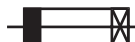

This symbol located near the fuse indicates that the fuse used is show operating type, For continued protection against fire hazard, replace with same type fuse , For fuse rating, refer to the marking adjust to the symbol.

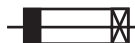

Ce symbole indique que le fusible utilise est e lent. Pour une protection permanente, n'utiliser que des fusibles de meme type. Ce demier est indique la qu le present symbol est appose.

LASER BEAM CAUTION LABEL



WAVE LENGTH:650nm
MAX LASER POWER:0.5mW
波 長: 650nm
最大レーザー出力: 0.5mW

98764160



REF. NO.	PART NO.	DESCRIPTION
F1	252252 or 252147	1.6A-TL/T-ST2 <MDD>,<MDC> 1.6A-TSC
F1	252273 or	1.6A-SE-TL250V Except <MDD,MDC> model

<MDD> : North American model

<MDC> : Canadian model

SERVICE PROCEDURES-2

2. Safety-check out

(Only U.S.A. model)

After correcting the original service problem perform the following safety check before releasing the set to the customer
Connect the insulating-resistance tester between the plug of power supply cord and terminal GND on the back panel.

Specifications: More than 10M ohm at 500V

INITIALIZING

Factory-shipped condition.

Connect the power cord to inlet terminal.

Push button "ON" (Mechanical SW). Lighting the LED condition.

Press the [STOP] and [STANDBY] same time with NO DISC condition.

Push button "STANDBY".

Pull out the power cord.

REMOVE THE SOLDER OF LASER DIODE SHORT

When replace the mechanism or DVD main PC board.

Shorting the solder of Shot-circuit land. (2 positions)

Mechanism

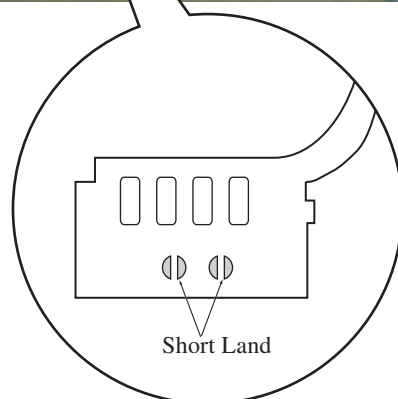
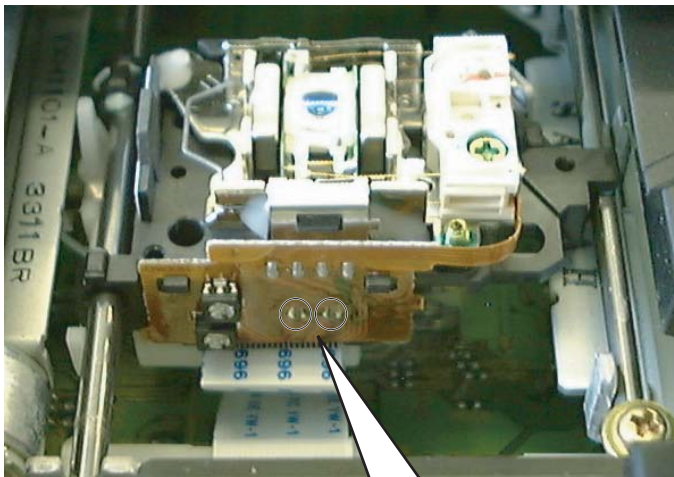

EXPLODED VIEW

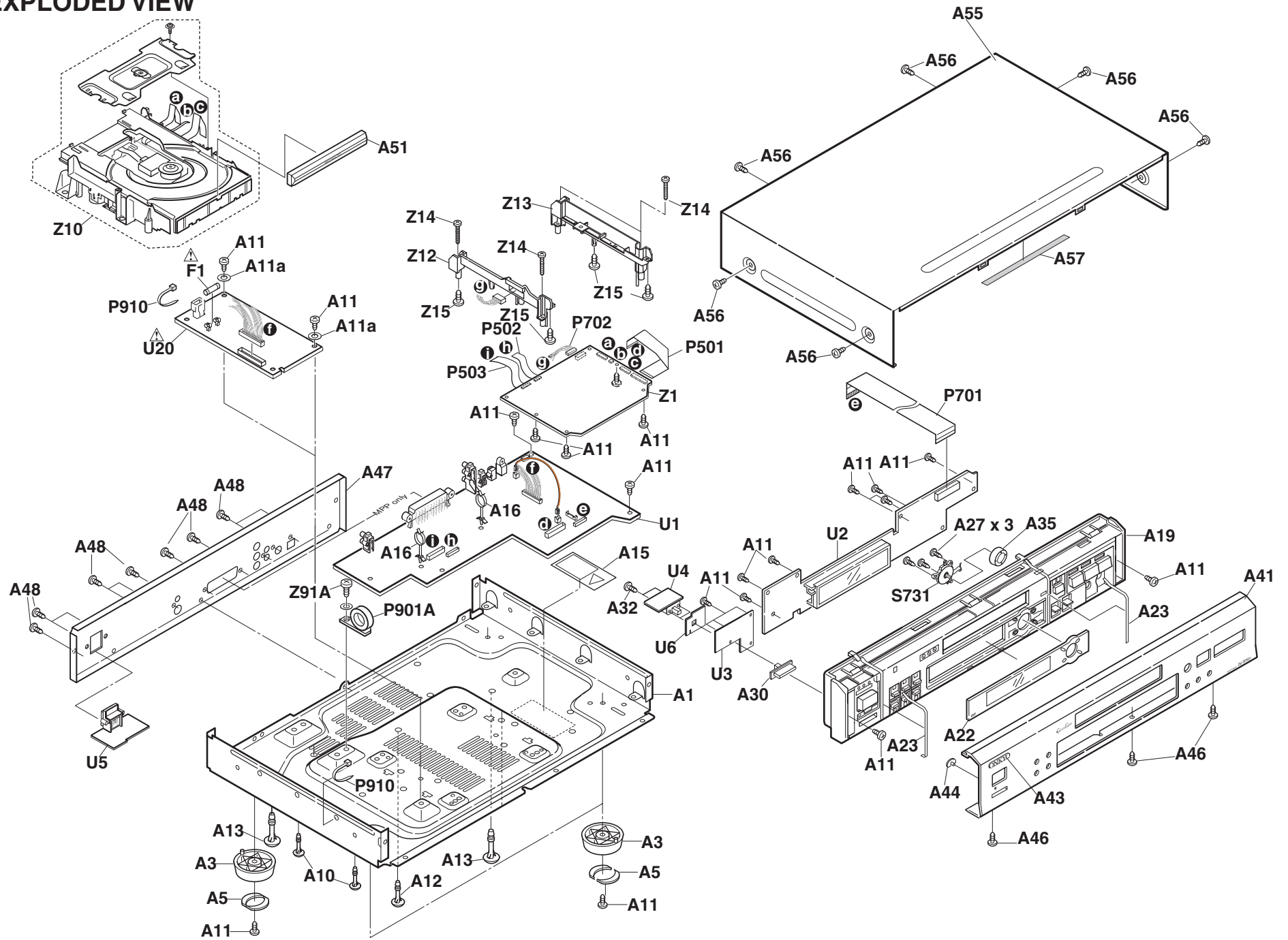

EXPLODED VIEW TRAVERSE MECHANISM

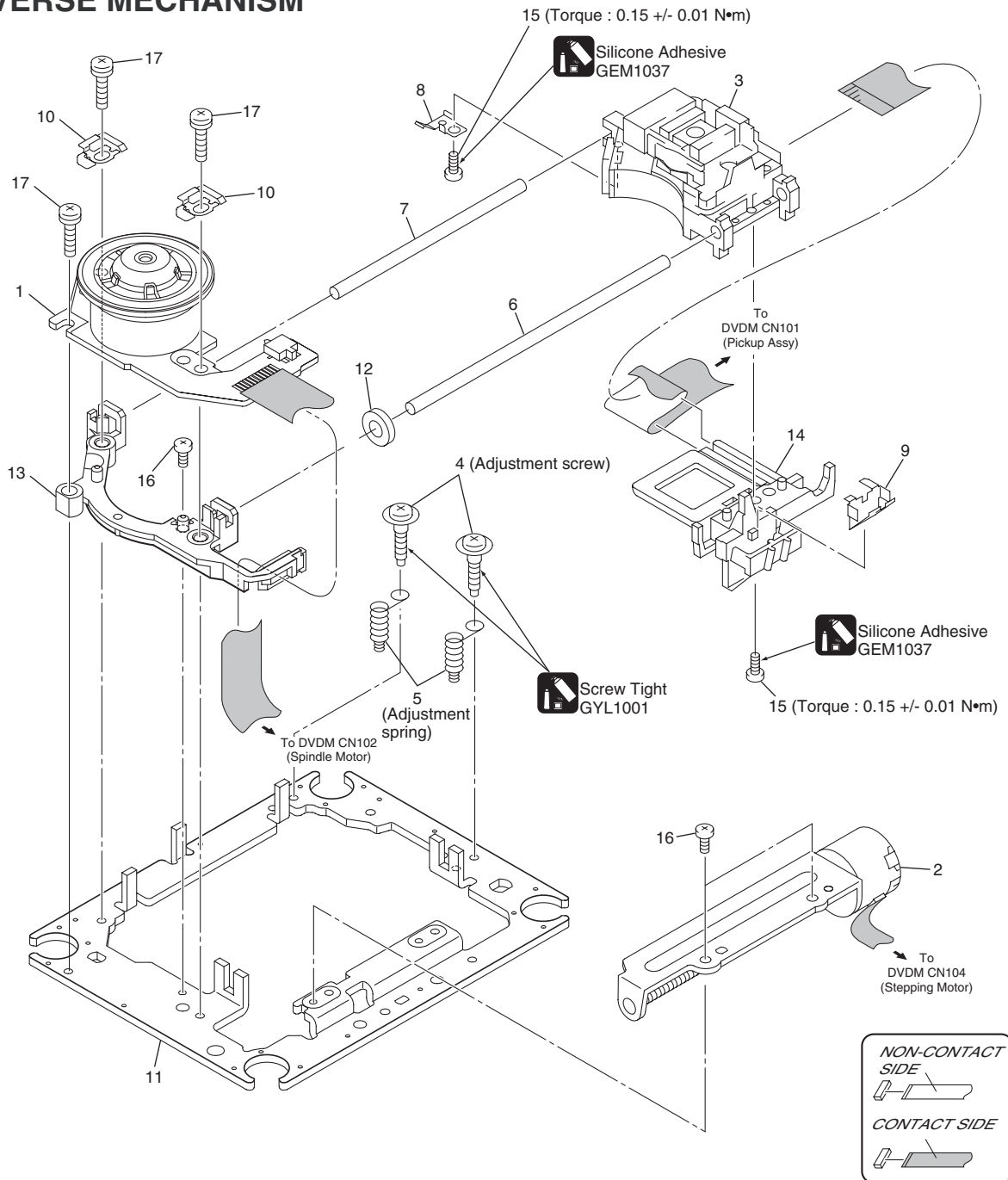

TRAVERSE MECHA ASSY parts List

Mark No.	Description	Part No.	Mark No.	Description	Part No.
1	Spindle Motor	VXM1099	9	Joint Spring	VNC1019
2	Stepping Motor	VXM1101	NSP 10	Support Spring	VNC1020
3	Pickup Assy-S	OXX8005	11	Mecha.Chassis	VNE2248
4	Skew Screw	VBA1080	12	Damper Sheet	VEB1335
5	Skew Spring	VBH1335	13	Spacer	VNL1913
6	Guide Bar	VLL1514	14	Joint O3	VNL1949
7	Sub Guide Bar	VLL1515	15	Tapping Screw	OBA8016
8	Leaf Spring	VNC1023	16	Screw	BBZ20P050FZK
			17	Screw	PMA26P100FMC

EXPLODED VIEW / PARTS LIST

LOADING MECHANISM

Note :



Refer to " ■ Application of Lubricant".

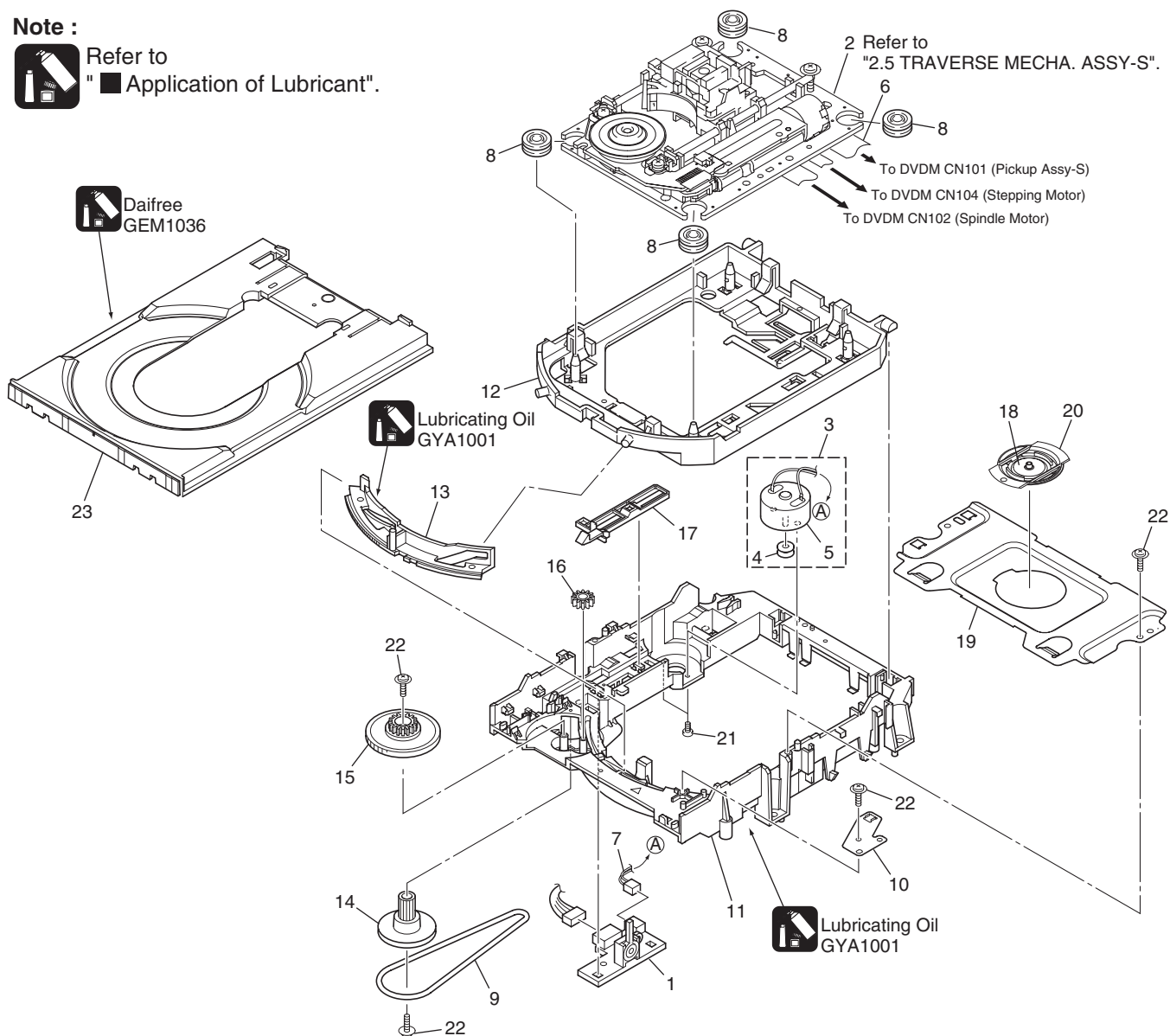

LOADING MECHA ASSY parts List

Mark No.	Description	Part No.	Mark No.	Description	Part No.
NSP 1	LOAB Assy	—	17	SW Lever	VNL1925
2	Traverse Mecha. Assy-S	VXX2871	18	Clamper Plate	VNE2251
3	Loading Motor Assy	VXX2872	19	Bridge	VNE2252
4	Motor Pulley	—	20	Clamper	VNL1924
5	Motor	—	21	Screw	JGZ17P028FMC
6	Flexible Cable (24P)	VDA1945	22	Screw	801530
7	Connector Assy 2P	VKP2253	23	Tray	VNL1920
8	Floating Rubber	VEB1351			
9	Belt	VEB1330			
10	Stabilizer	VNE2253			
11	Loading Base	VNL1917			
12	Float Base DVD	VNL1918			
13	Drive Cam	VNL1919			
14	Gear Pulley	VNL1921			
15	Loading Gear	VNL1922			
16	Drive Gear	VNL1923			

NSP: Not service parts

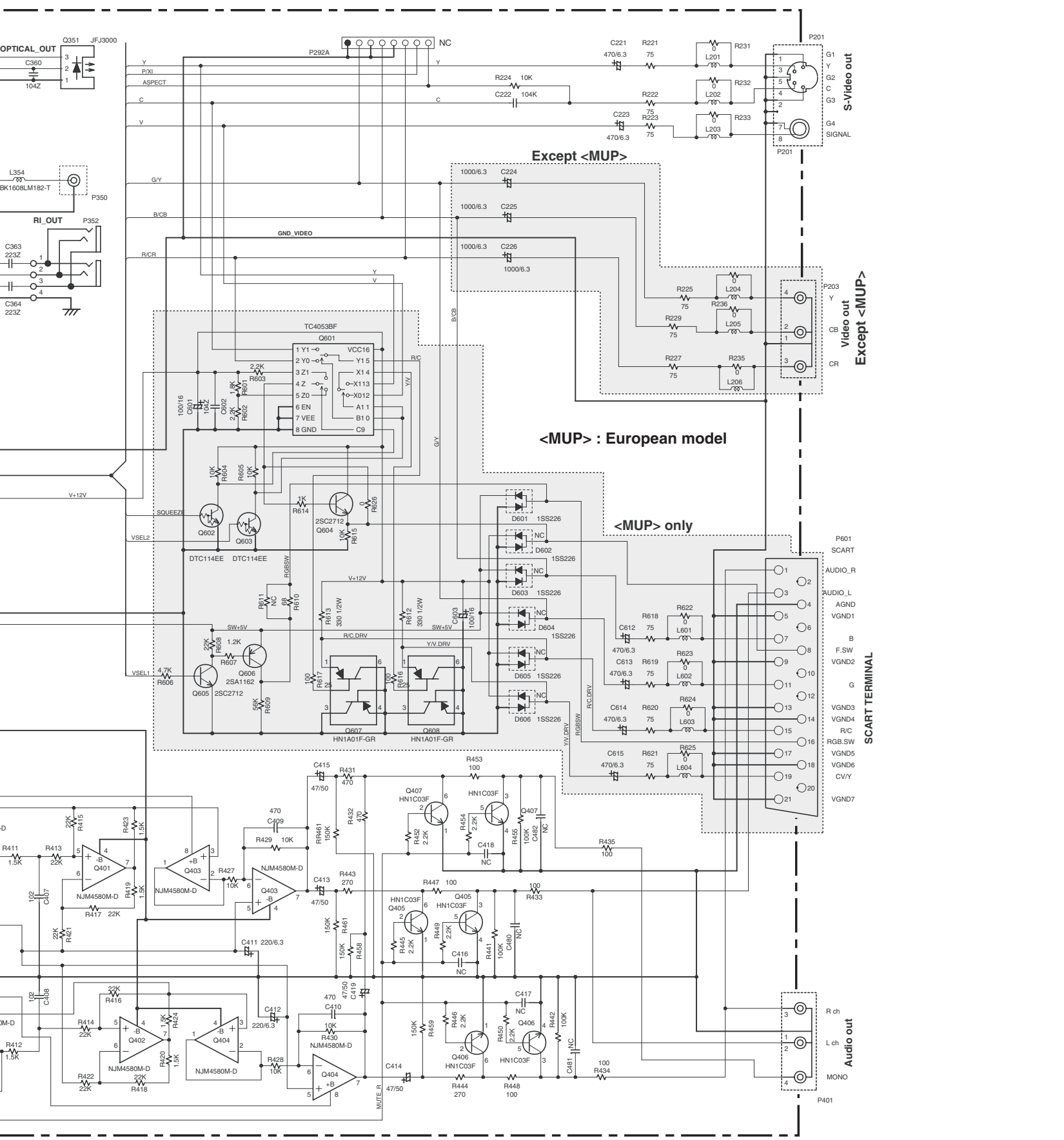

SCHEMATIC DIAGRAM U1 : OUTPUT TERMINAL PC BOARD

NAAR-7997

1

2

3

4

5

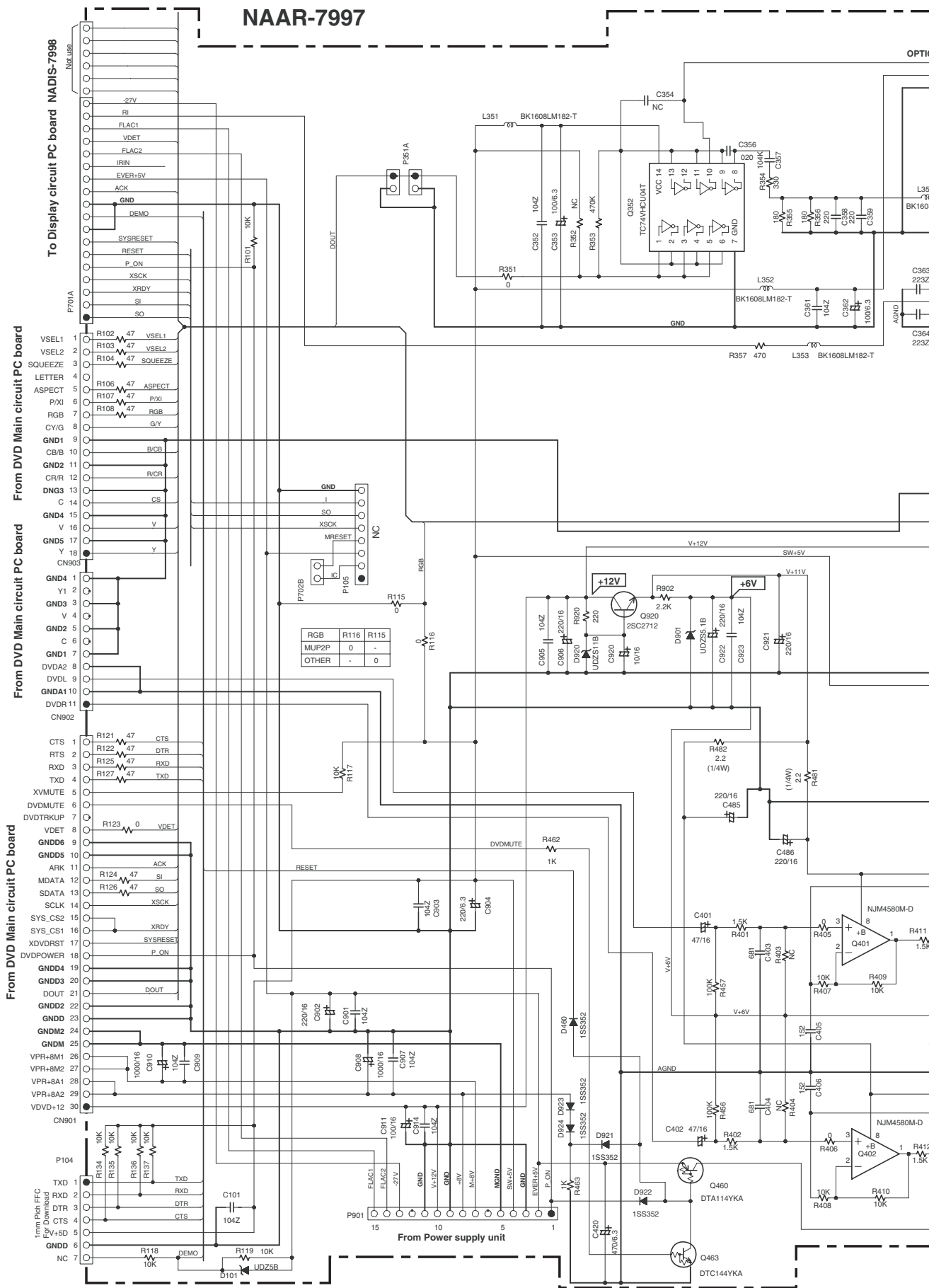

OPTI

L35

BK160

C363

2232

C364

2232

AGND

L357

BK160

C365

2232

C366

2232

C367

2232

C368

2232

C369

2232

C370

2232

C371

2232

C372

2232

C373

2232

C374

2232

C375

2232

C376

2232

C377

2232

C378

2232

SCHEMATIC DIAGRAM U1: OUTPUT TERMINAL PC BOARD

1

2

3

4

5

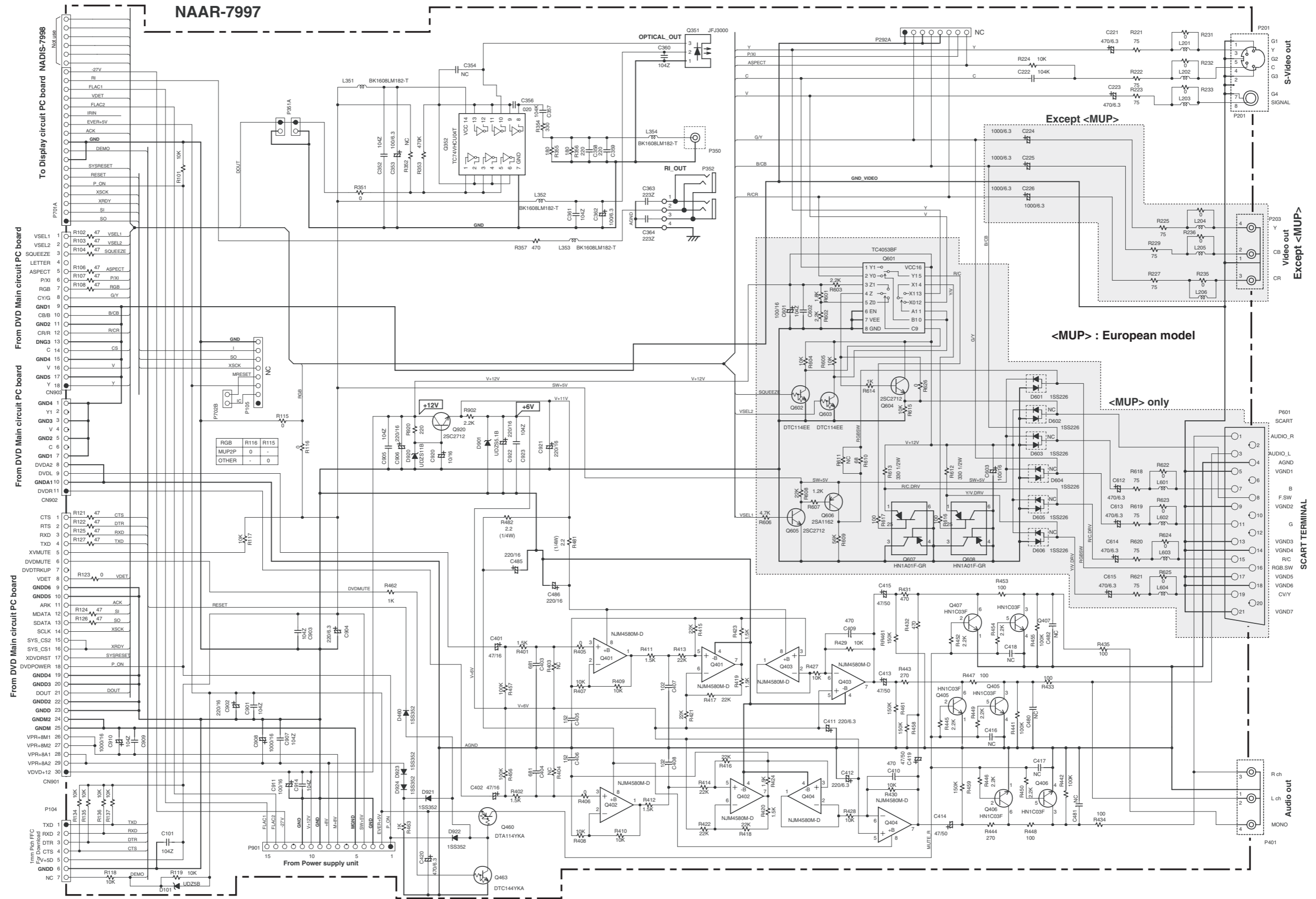

To Display circuit PC board NADIS-7998

From DVD Main circuit PC board

From DVD Main circuit PC board

From DVD Main circuit PC board

From Power supply unit

S-Video out

Video out Except <MUP>

<MUP> : European model

<MUP> only

SCART TERMINAL

Audio out

	MJJ	MDD	MUP	MUT/MUK	MUS/MUA	MUR
Region	2	1	2	3	4	6
R738	0	0	NC	0	0	NC
R739	NC	NC	1K	NC	NC	1K
R740	0	0	0	NC	NC	NC
R741	NC	NC	NC	1K	1K	1K
R742	0	NC	0	0	0	NC
R743	NC	1K	NC	NC	NC	1K

U3: STANDBY SWITCH PC BOARD NADIS-7999

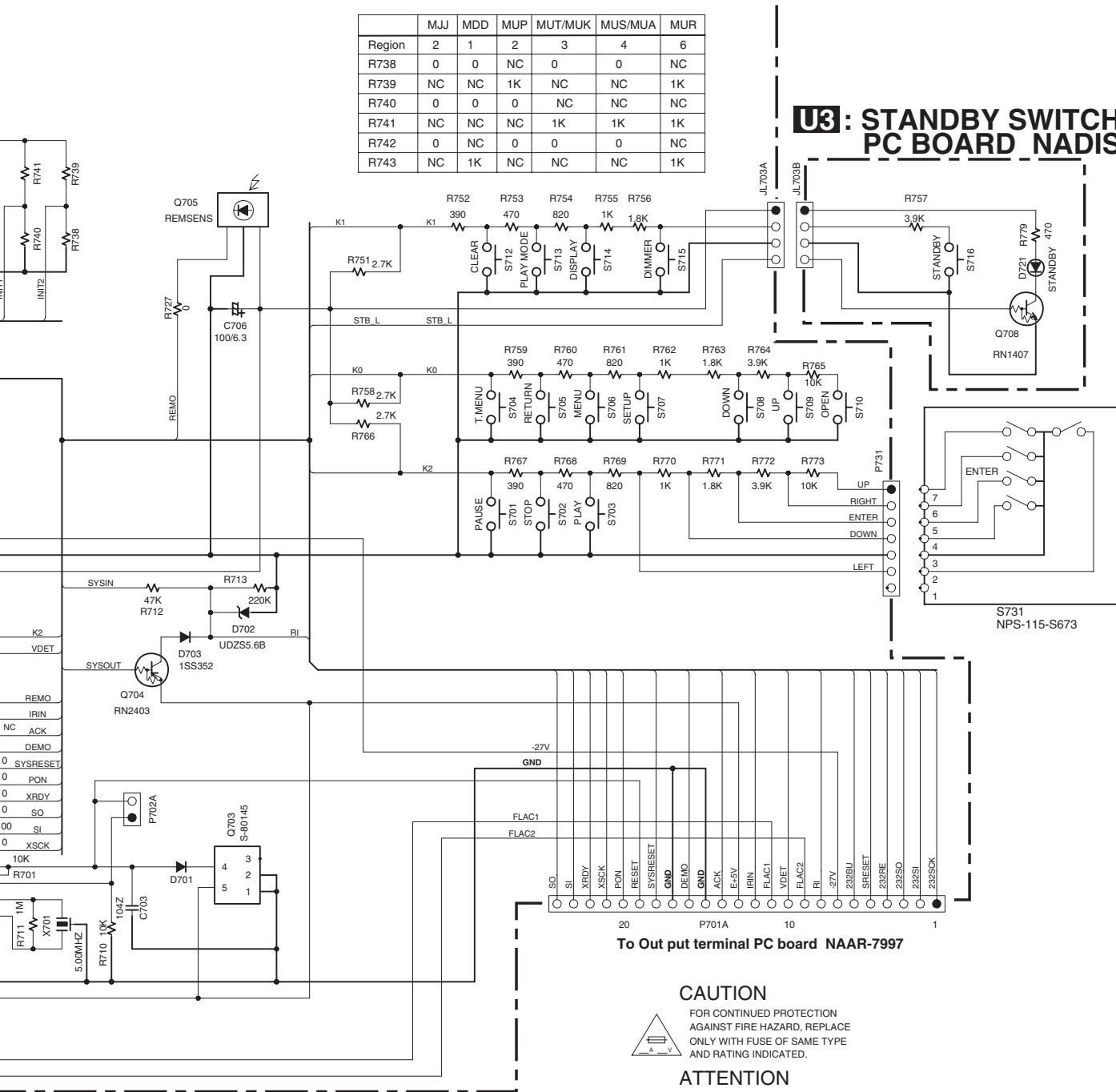

To Out put terminal PC board NAAR-7997

CAUTION

FOR CONTINUED PROTECTION AGAINST FIRE HAZARD, REPLACE ONLY WITH FUSE OF SAME TYPE AND RATING INDICATED.



ATTENTION

AFIN D'ASSURER UNE PROTECTION PERMANENTE CONTRE LES RISQUES D'INCENDIE, REMPLACER UNIQUEMENT PAR UN FUSIBLE DE MEME TYPE ET CALIBRATION COMME INDIQUE.



THIS SYMBOL LOCATED NEAR THE FUSE INDICATES THAT THE FUSE USED IS SLOW OPERATING TYPE FOR CONTINUED PROTECTION AGAINST FIRE HAZARD, REPLACE WITH SAME TYPE FUSE. FOR FUSE RATING REFER TO THE MARKING ADJACENT TO THE SYMBOL.

CE SYMBOLE INDIQUE QUE LE FUSIBLE UTILISE EST E LENT. POUR UNE PROTECTION PERMANENTE, N'UTILISER QUE DES FUSIBLES DE MEME TYPE. CE DARNIER EST INDIQUE LA QU LE PRESENT SYMBOLE EST APPOSE.

U5: INLET TERMINAL PC BOARD NAPS-8001

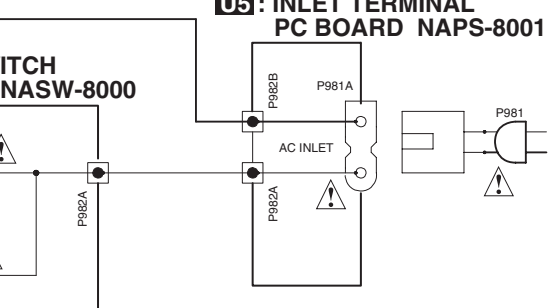

ITCH NASW-8000

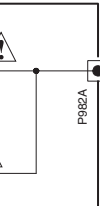

A

B

C

D

SCHEMATIC DIAGRAM

1

U2 : DISPLAY CIRCUIT PC BOARD NADIS-7998

2

3

4

5

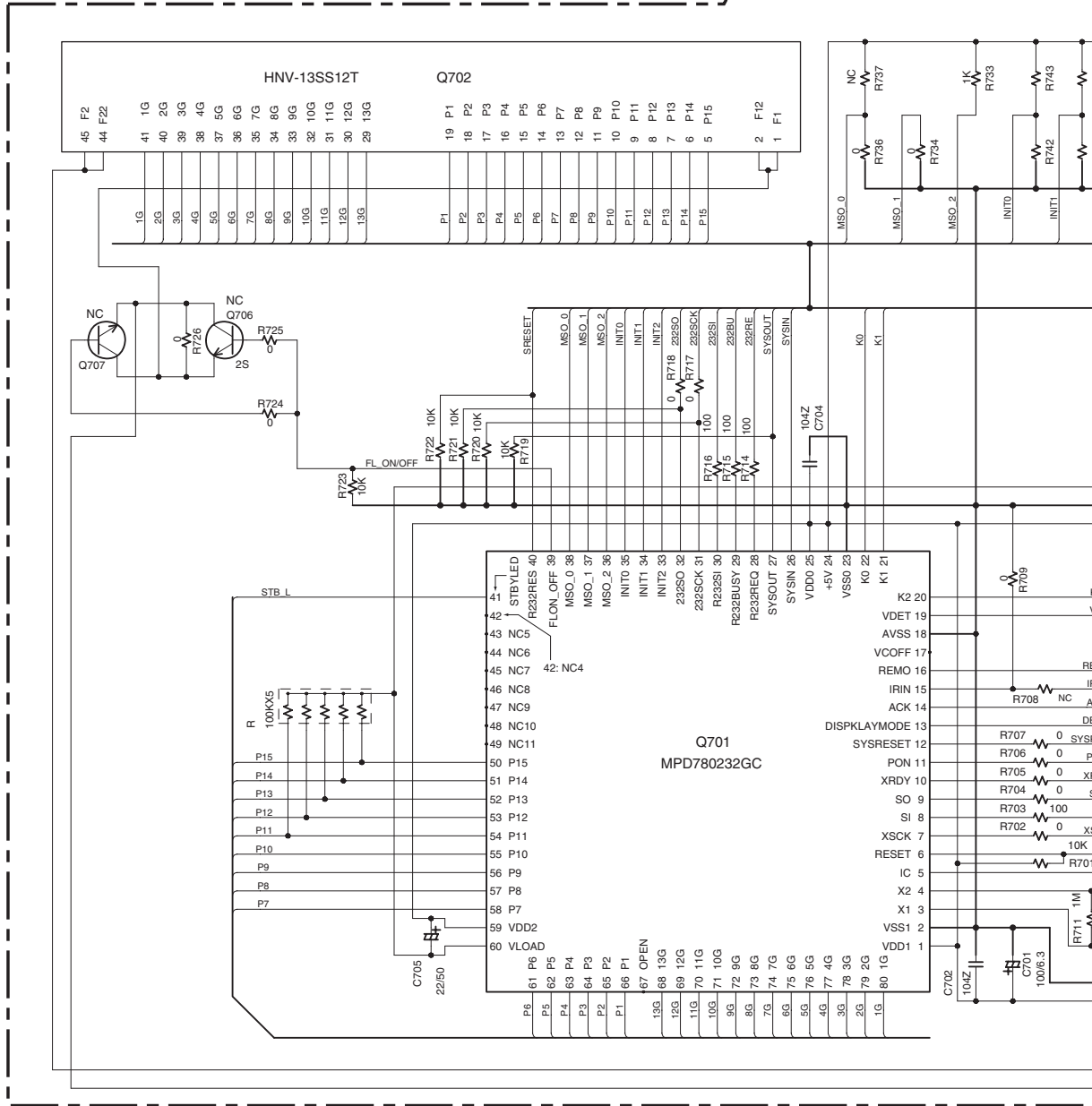

U20 : POWER SUPPLY UNIT

NGPS-0040 AC100-120V 50Hz/60Hz
 NGPS-0041 AC100-240V 50Hz/60Hz



To Out put terminal PC board NAAR-7997 CN901

U4 : POWER SWITCH PC BOARD NAS

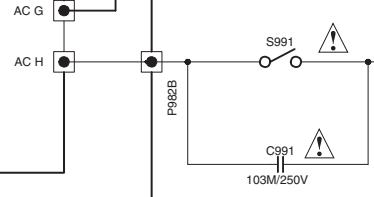

SCHEMATIC DIAGRAM

1
2
3
4
5

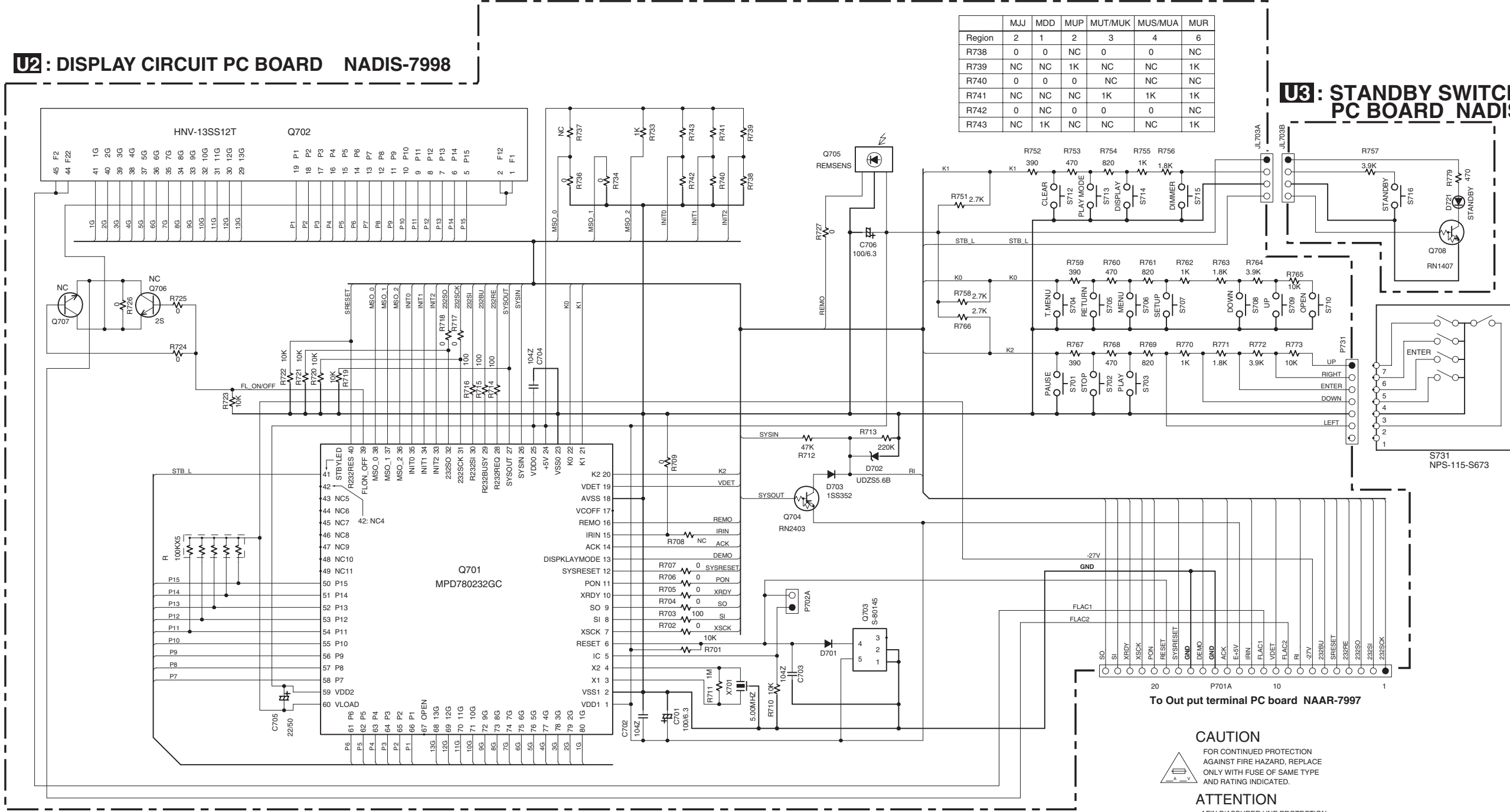

	MJJ	MDD	MUP	MUT/MUK	MUS/MUA	MUR
Region	2	1	2	3	4	6
R738	0	0	NC	0	0	NC
R739	NC	NC	1K	NC	NC	1K
R740	0	0	0	NC	NC	NC
R741	NC	NC	NC	1K	1K	1K
R742	0	NC	0	0	0	NC
R743	NC	1K	NC	NC	NC	1K

U2: DISPLAY CIRCUIT PC BOARD NADIS-7998

U3: STANDBY SWITCH PC BOARD NADIS-7999

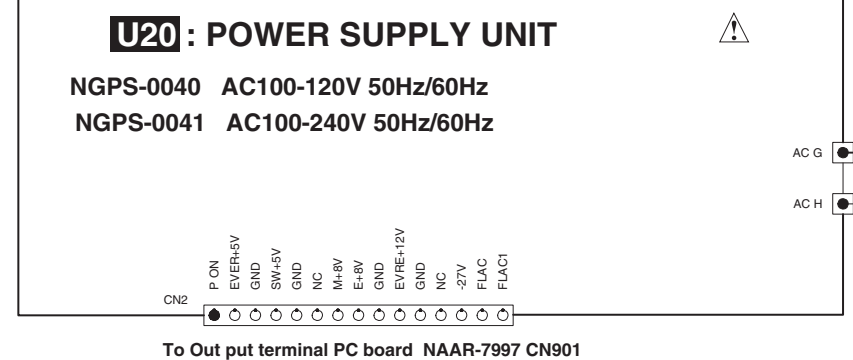

U20: POWER SUPPLY UNIT
 NGPS-0040 AC100-120V 50Hz/60Hz
 NGPS-0041 AC100-240V 50Hz/60Hz

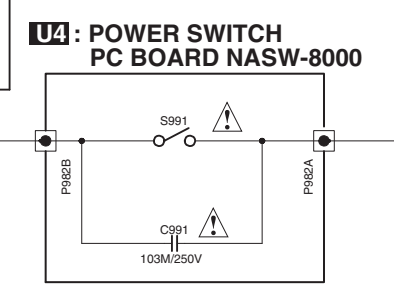

U4: POWER SWITCH PC BOARD NASW-8000

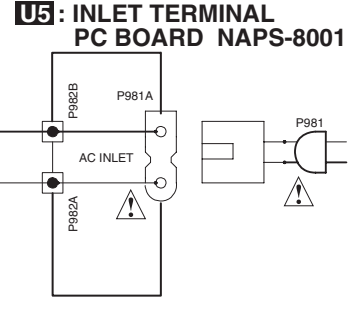

U5: INLET TERMINAL PC BOARD NAPS-8001

CAUTION
 FOR CONTINUED PROTECTION AGAINST FIRE HAZARD, REPLACE ONLY WITH FUSE OF SAME TYPE AND RATING INDICATED.

ATTENTION
 AFIN D'ASSURER UNE PROTECTION PERMANENTE CONTRE LES RISQUES D'INCENDIE, REMPLACER UNIQUEMENT PAR UN FUSIBLE DE MEME TYPE ET CALIBRATION COMME INDIQUE.

THIS SYMBOL LOCATED NEAR THE FUSE INDICATES THAT THE FUSE USED IS SLOW OPERATING TYPE FOR CONTINUED PROTECTION AGAINST FIRE HAZARD, REPLACE WITH SAME TYPE FUSE. FOR FUSE RATING REFER TO THE MARKING ADJACENT TO THE SYMBOL.

CE SYMBOLE INDIQUE QUE LE FUSIBLE UTILISE EST E LENT. POUR UNE PROTECTION PERMANENTE, UTILISER QUE DES FUSIBLES DE MEME TYPE. CE DERNIER EST INDIQUE LA OU LE PRESENT SYMBOLE EST APPOSE.

To Out put terminal PC board NAAR-7997 CN901

To Out put terminal PC board NAAR-7997

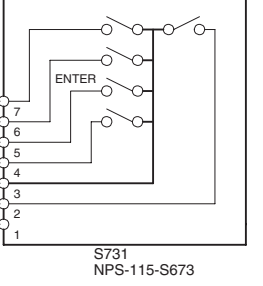

S731 NPS-115-S673

E

F

G

H

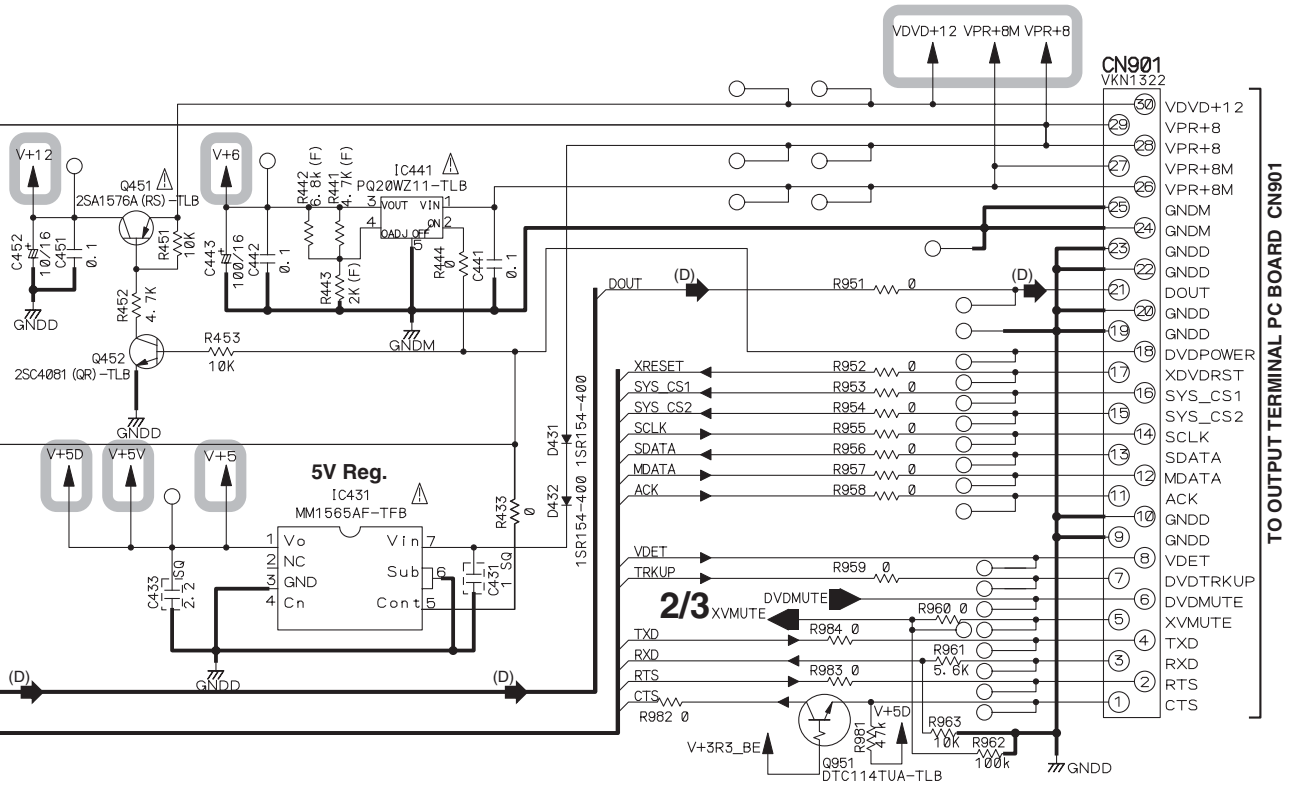

2/3

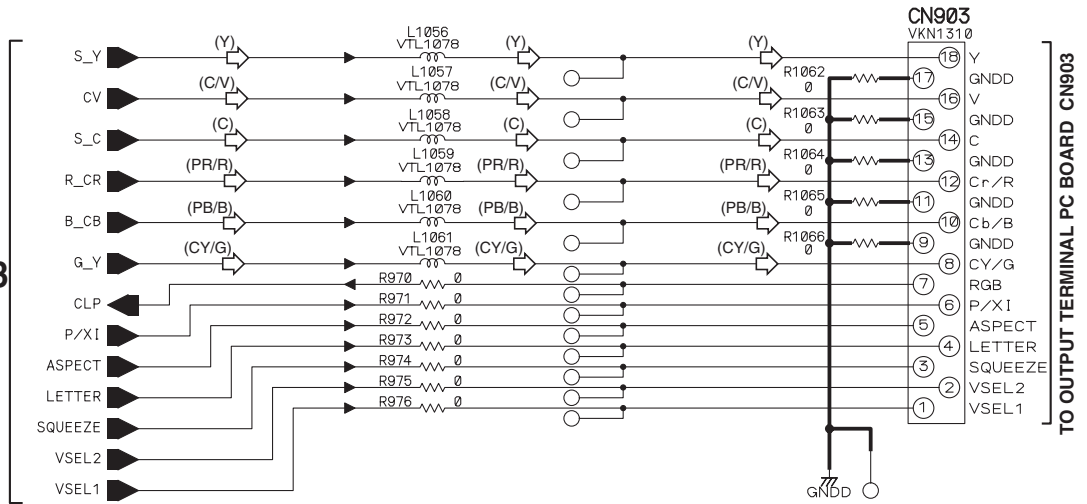

- (C/V) : VIDEO SIGNAL ROUTE (C/V)
- (Y) : S VIDEO SIGNAL ROUTE (Y)
- (C) : S VIDEO SIGNAL ROUTE (C)
- (PR/R) : VIDEO SIGNAL ROUTE (PR/R)
- (CY/G) : VIDEO SIGNAL ROUTE (CY/G)
- (PB/B) : VIDEO SIGNAL ROUTE (PB/B)
- (D) : AUDIO SIGNAL ROUTE (DIGITAL)

SCHEMATIC DIAGRAM DVD MAIN CIRCUIT PC BOARD (3/3) DB-VPB501/XJ

1
2
3
4
5

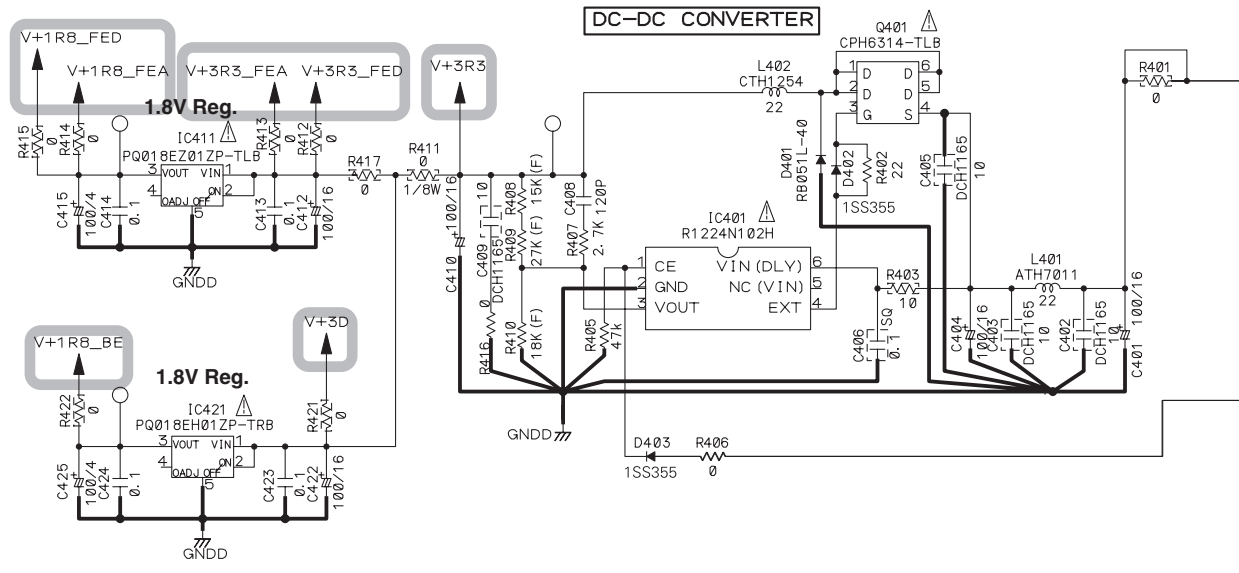

2/3 AUDIO (to page 2/3) (D)
 SYS (to page 2/3) (D)

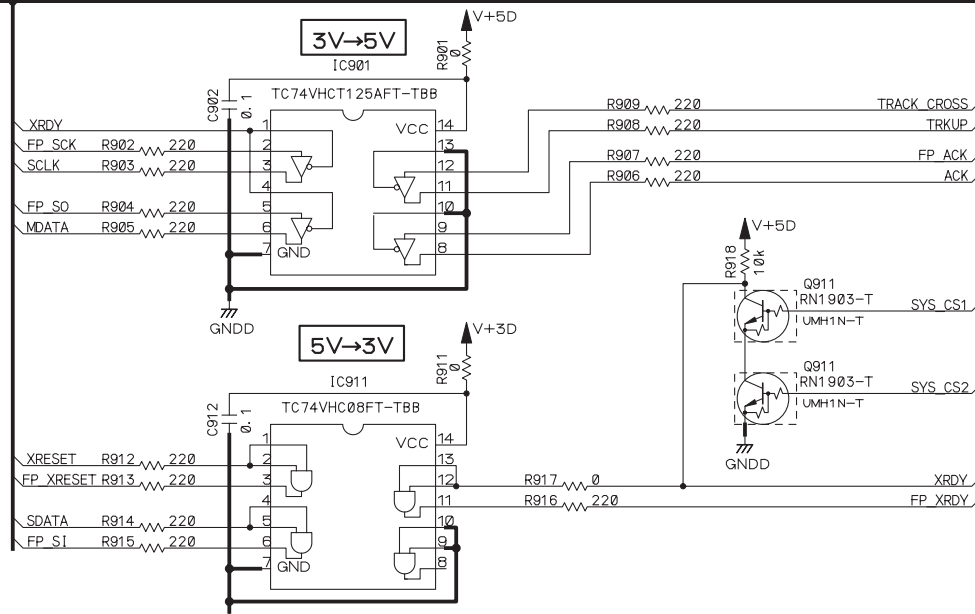

NORMAL : 3.3V
 ABNORMAL : <0.5VDD
 >0.85VDD

SCHMATIC DIAGRAM DVD MAIN CIRCUIT PC BOARD (3/3) DB-VPB501/XJ

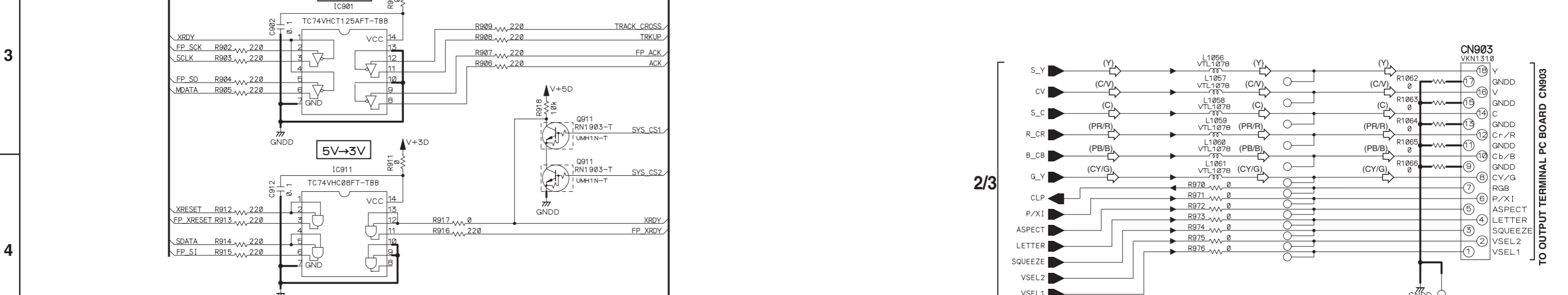
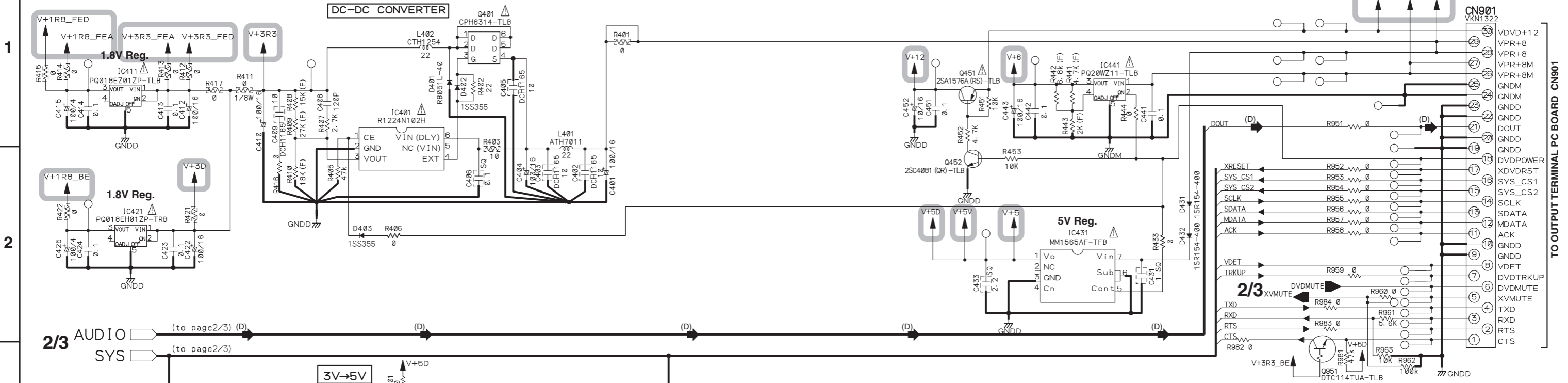

E F G H

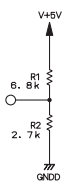
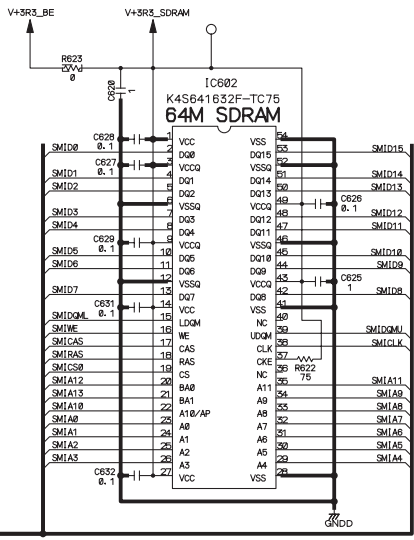

- ➔ FE_DATA SIGNAL ROUTE (RF)
- ➔ RF SIGNAL ROUTE (C/V)
- ➔ VIDEO SIGNAL ROUTE (C/V)
- ➔ S VIDEO SIGNAL ROUTE (Y)
- ➔ S VIDEO SIGNAL ROUTE (C)
- ➔ AUDIO DATA SIGNAL ROUTE (AD)
- ➔ AUDIO SIGNAL ROUTE (DIGITAL) (D)
- ➔ AUDIO SIGNAL ROUTE (DVD_L ch) (DVD)

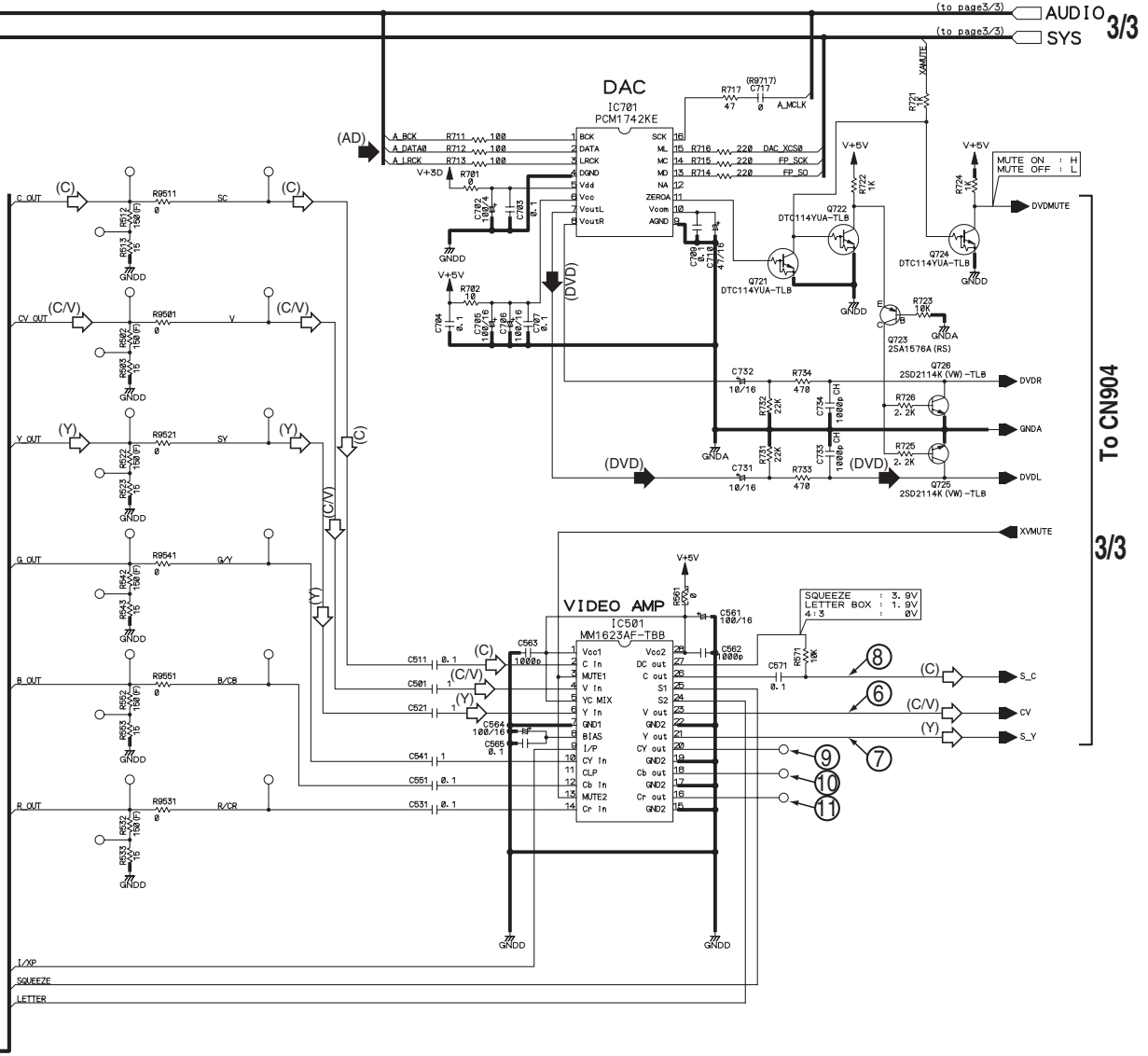

(to page3/3) AUDIO 3/3
(to page3/3) SYS

To CN904

3/3

(to page1/3) BE 1/3

SCHEMATIC DIAGRAM DVD MAIN CIRCUIT PC BOARD (2/3) DB-VPB501/XJ

1

2

3

4

5

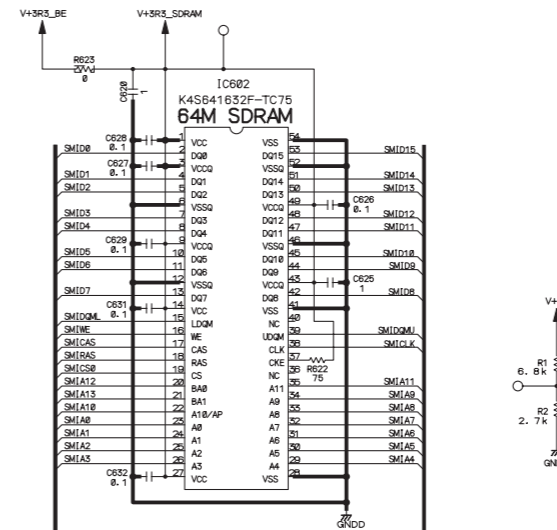
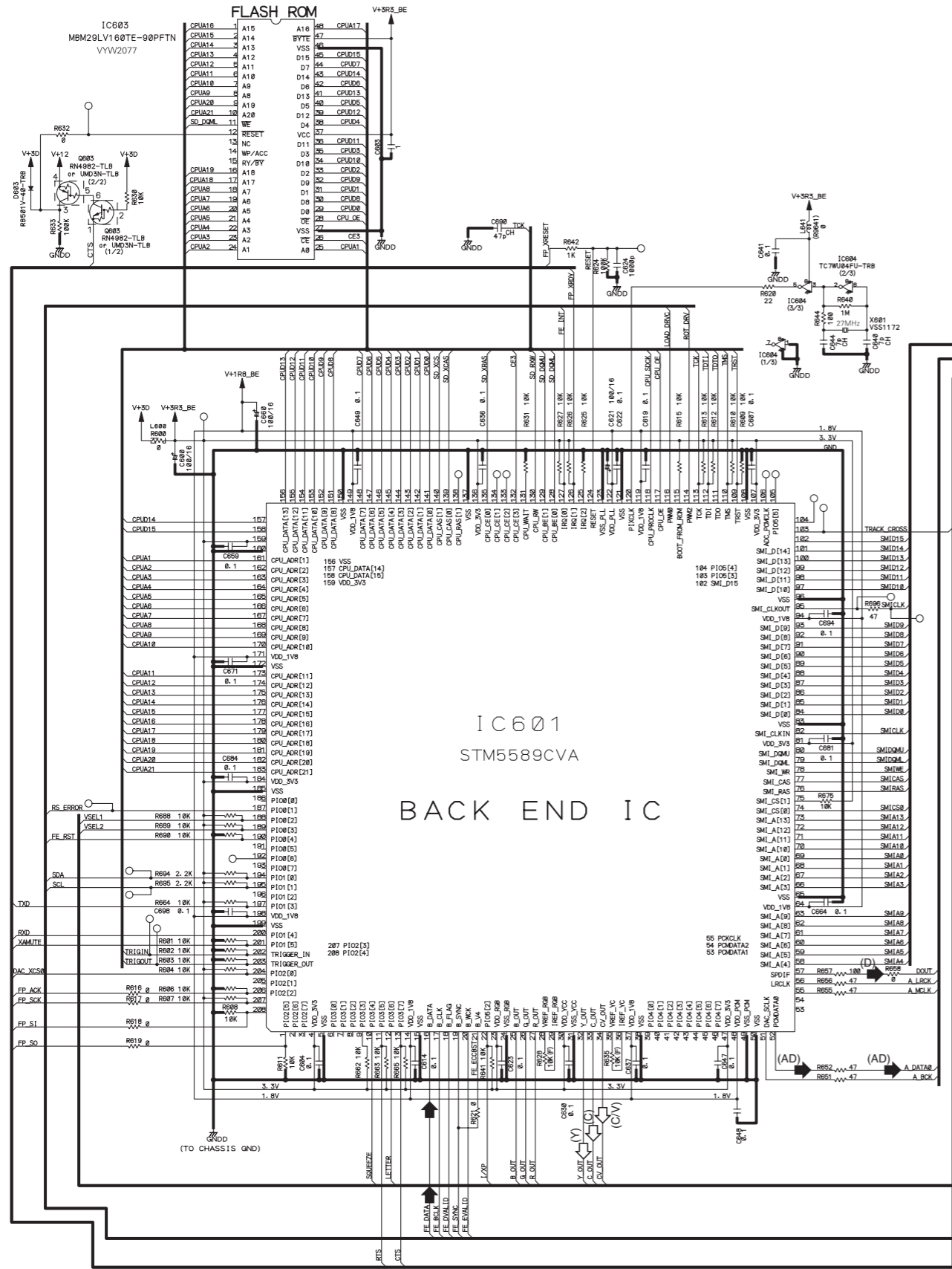

- FE_DATA SIGNAL ROUTE
- (RF) ➤ RF SIGNAL ROUTE
- (C/V) ➤ VIDEO SIGNAL ROUTE (C/V)
- (Y) ➤ S VIDEO SIGNAL ROUTE (Y)
- (C) ➤ S VIDEO SIGNAL ROUTE (C)
- (AD) ➤ AUDIO DATA SIGNAL ROUTE
- (D) ➤ AUDIO SIGNAL ROUTE (DIGITAL)
- (DVD) ➤ AUDIO SIGNAL ROUTE (DVD_L ch)

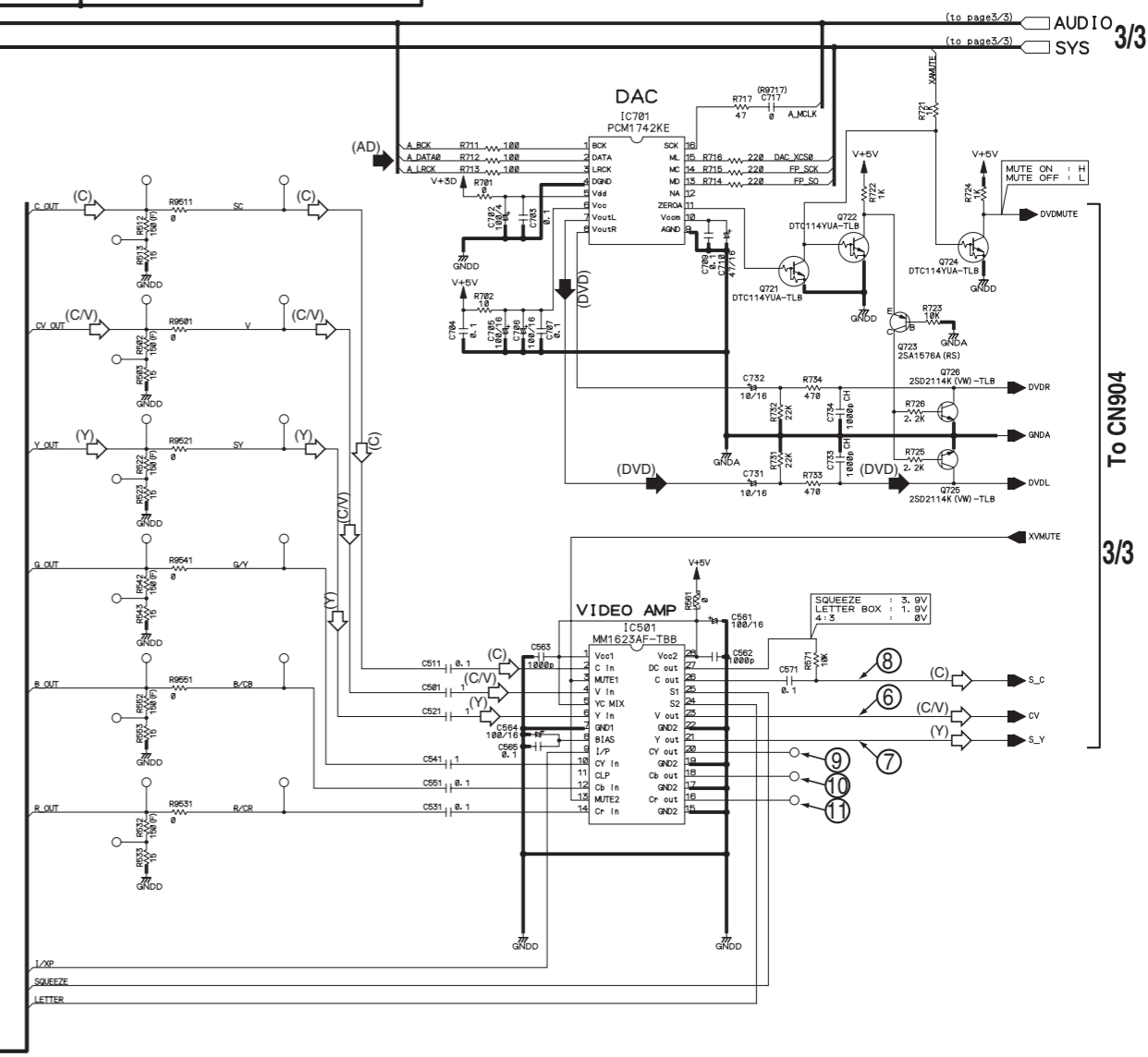

- (RF) RF SIGNAL ROUTE
- (F) FOCUS SERVO LOOP LINE
- (T) TRACKING SERVO LOOP LINE
- (S) STEPPING SERVO LOOP LINE

(RF) (to page 2/3) BE 2/3

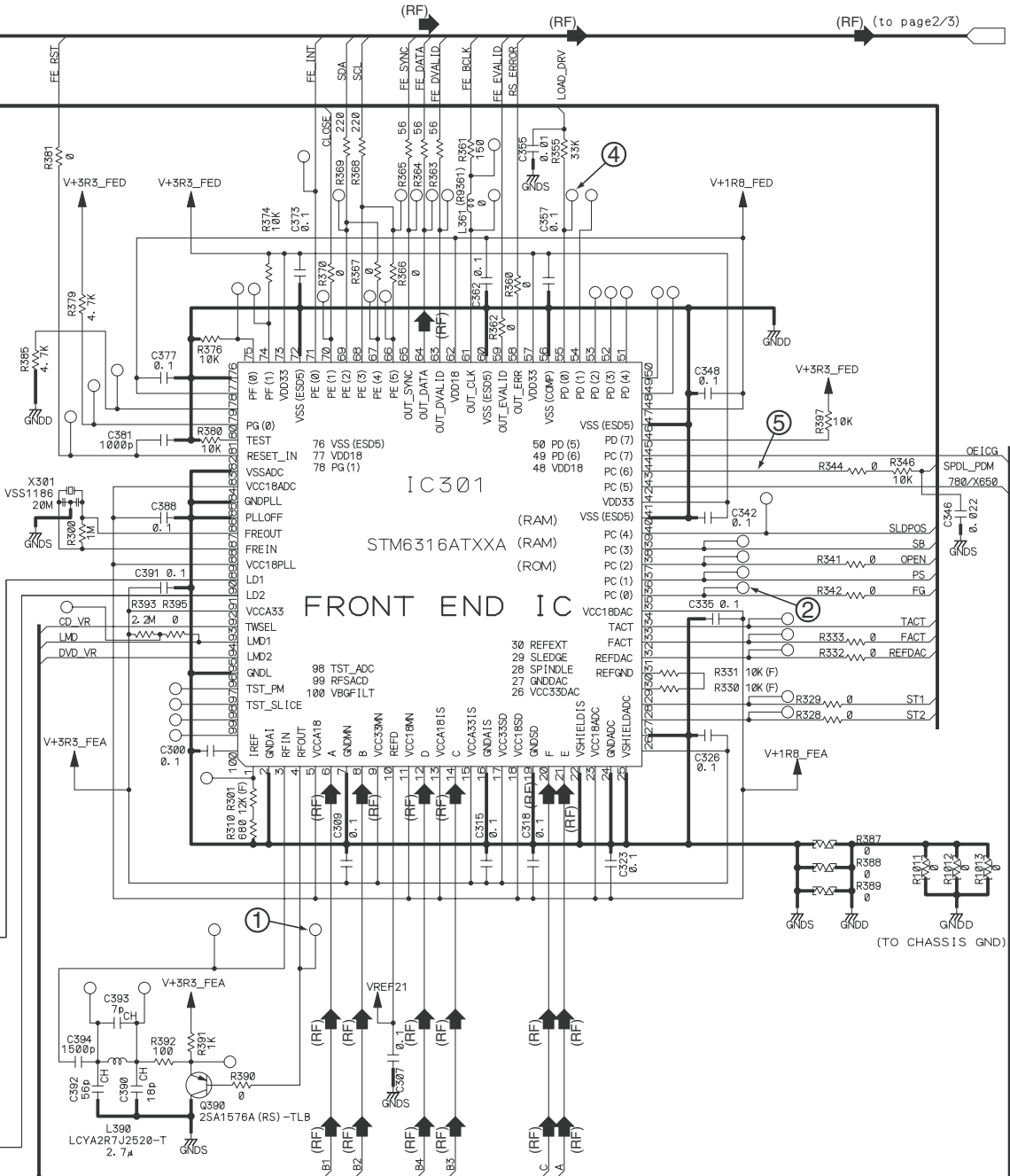

SCHEMATIC DIAGRAM DVD MAIN CIRCUIT PC BOARD (1/3) DB-VPB501/XJ

1
 2
 3
 4
 5

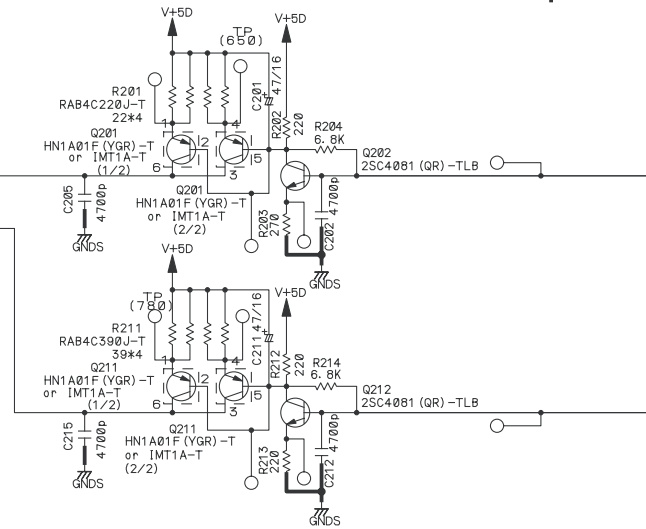
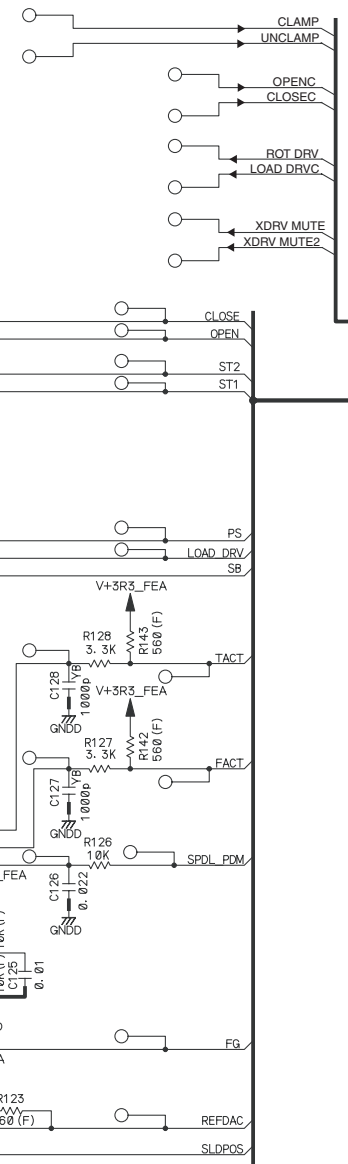
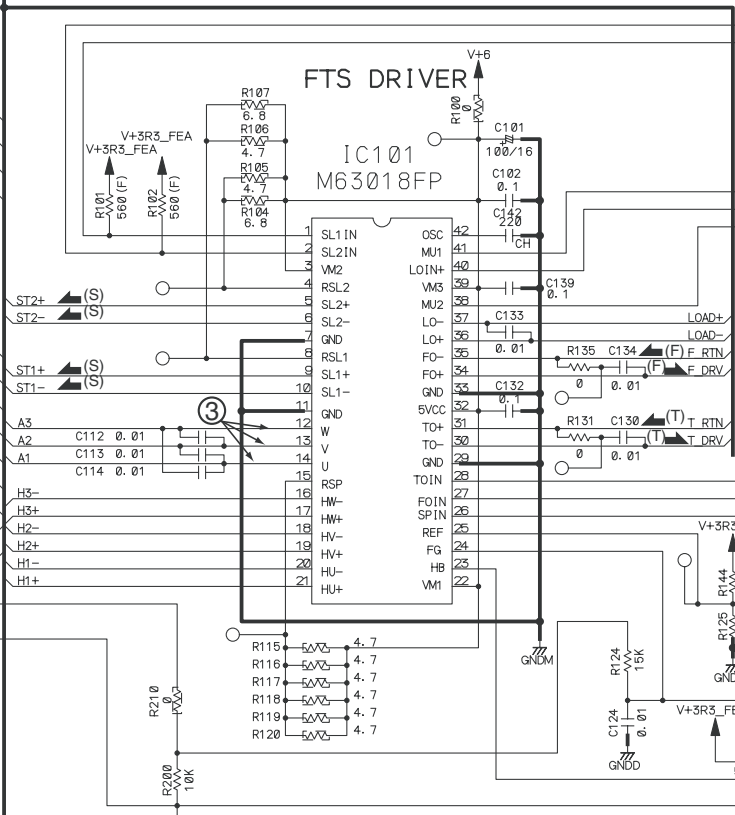
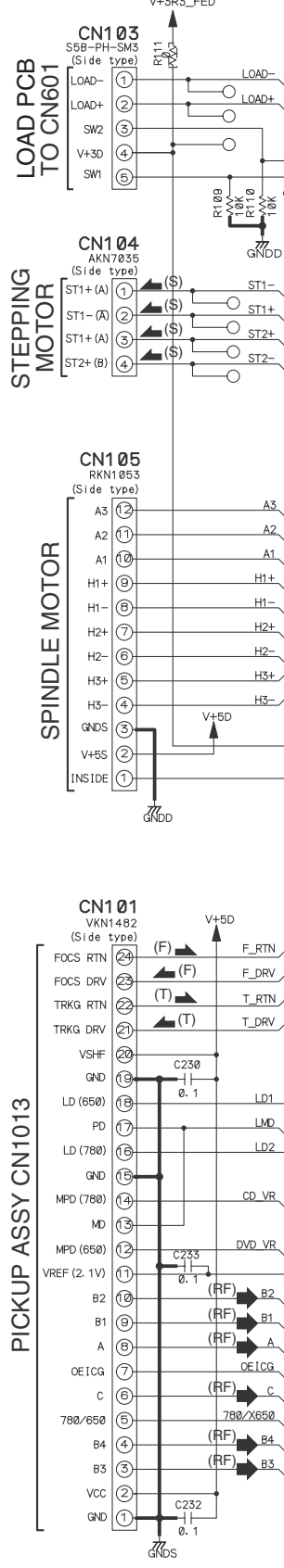

SCHEMATIC DIAGRAM DVD MAIN CIRCUIT PC BOARD (1/3)
DB-VPB501/XJ

1
2
3
4
5

(RF) : RF SIGNAL ROUTE
(F) : FOCUS SERVO LOOP LINE
(T) : TRACKING SERVO LOOP LINE
(S) : STEPPING SERVO LOOP LINE

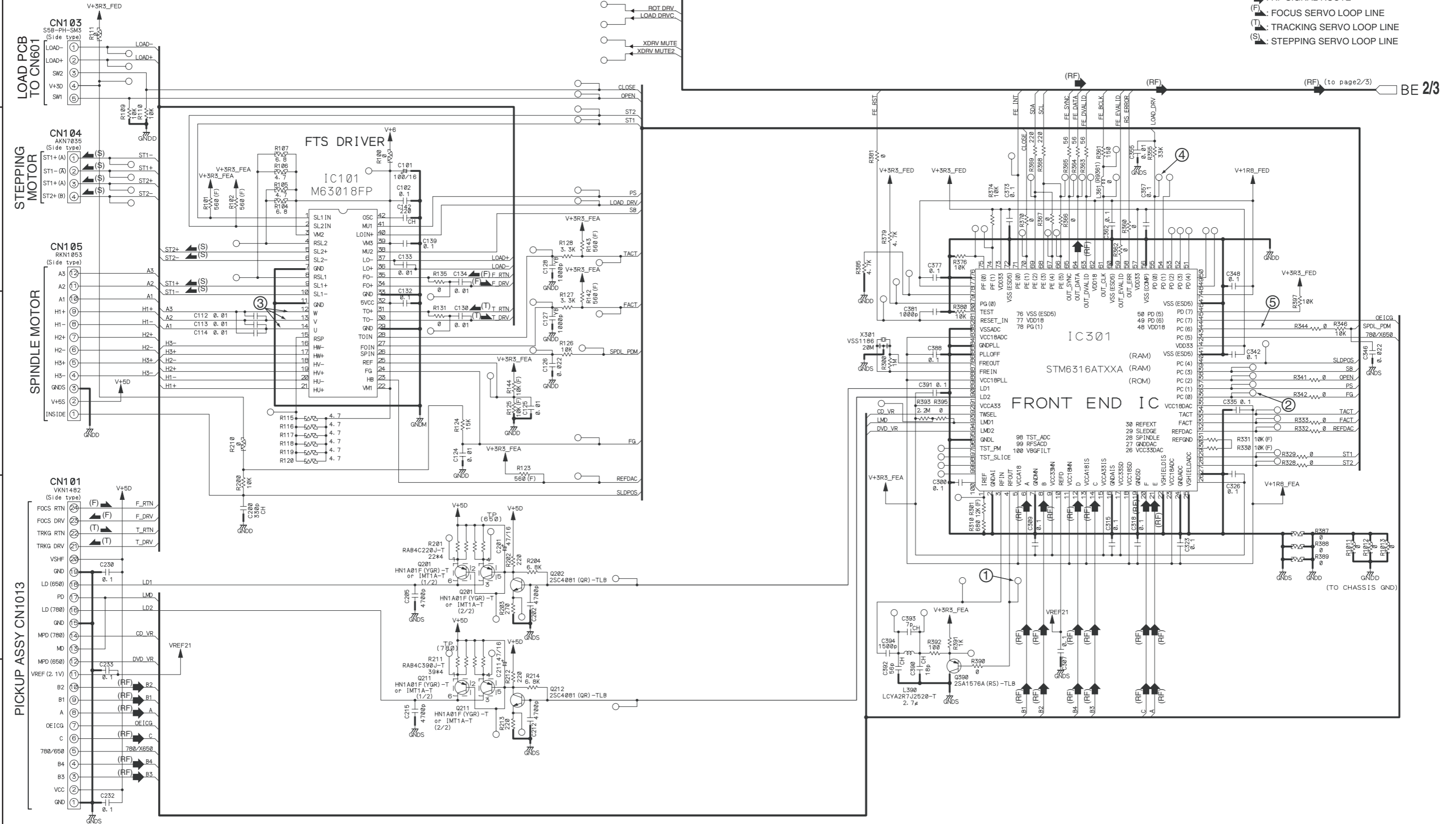

BE 2/3

SCHEMATIC DIAGRAM

U20 : POWER SUPPLY UNIT
NGPS-0040-100-120V <MDD/ MDC>
NGPS-0041-100-240V Except <MDD/ MDC>

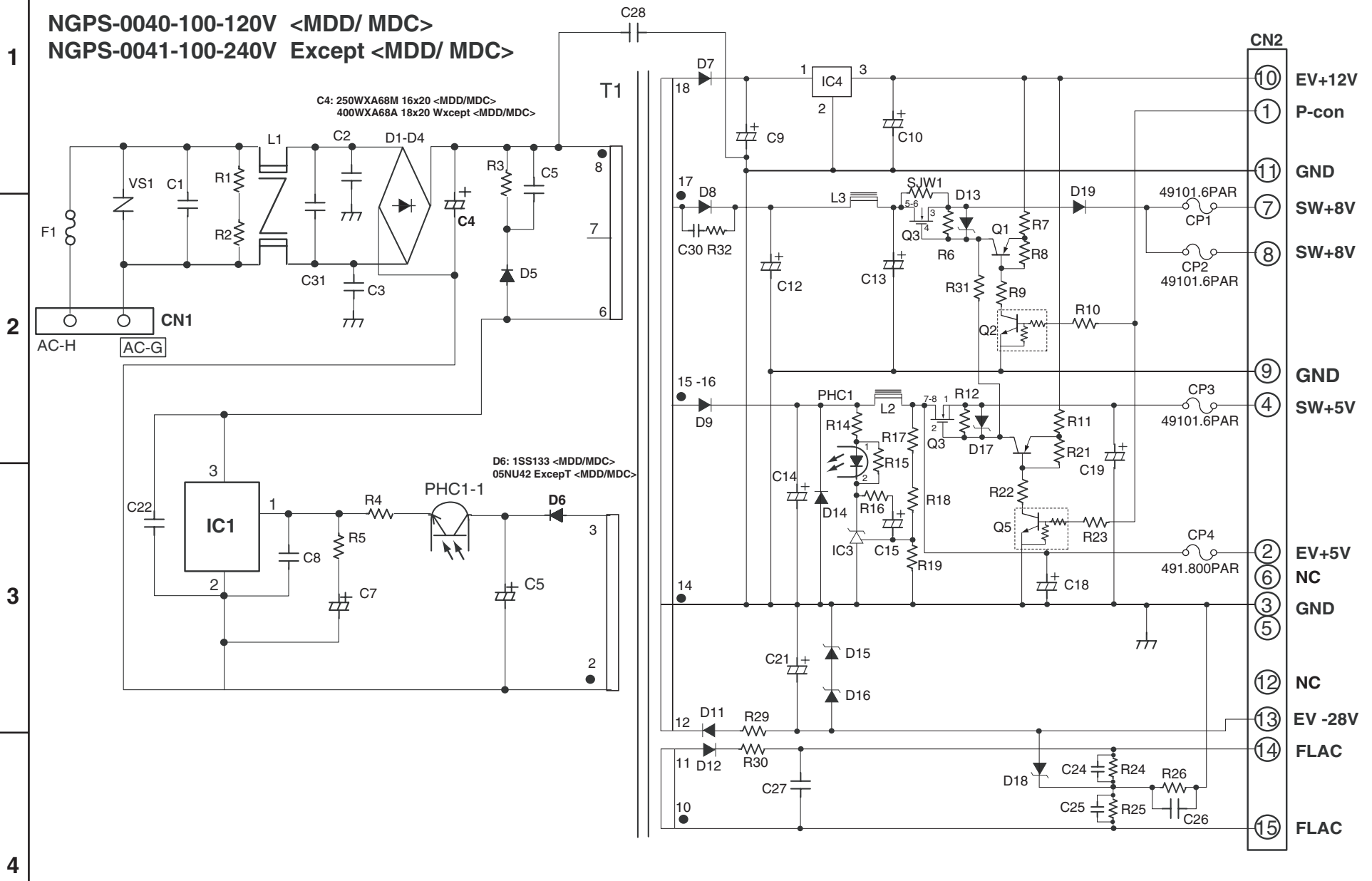

- 10 EV+12V
- 1 P-con
- 11 GND
- 7 SW+8V
- 8 SW+8V
- 9 GND
- 4 SW+5V
- 2 EV+5V
- 6 NC
- 3 GND
- 5
- 12 NC
- 13 EV -28V
- 14 FLAC
- 15 FLAC

PC BOARD CONNECTION DIAGRAM

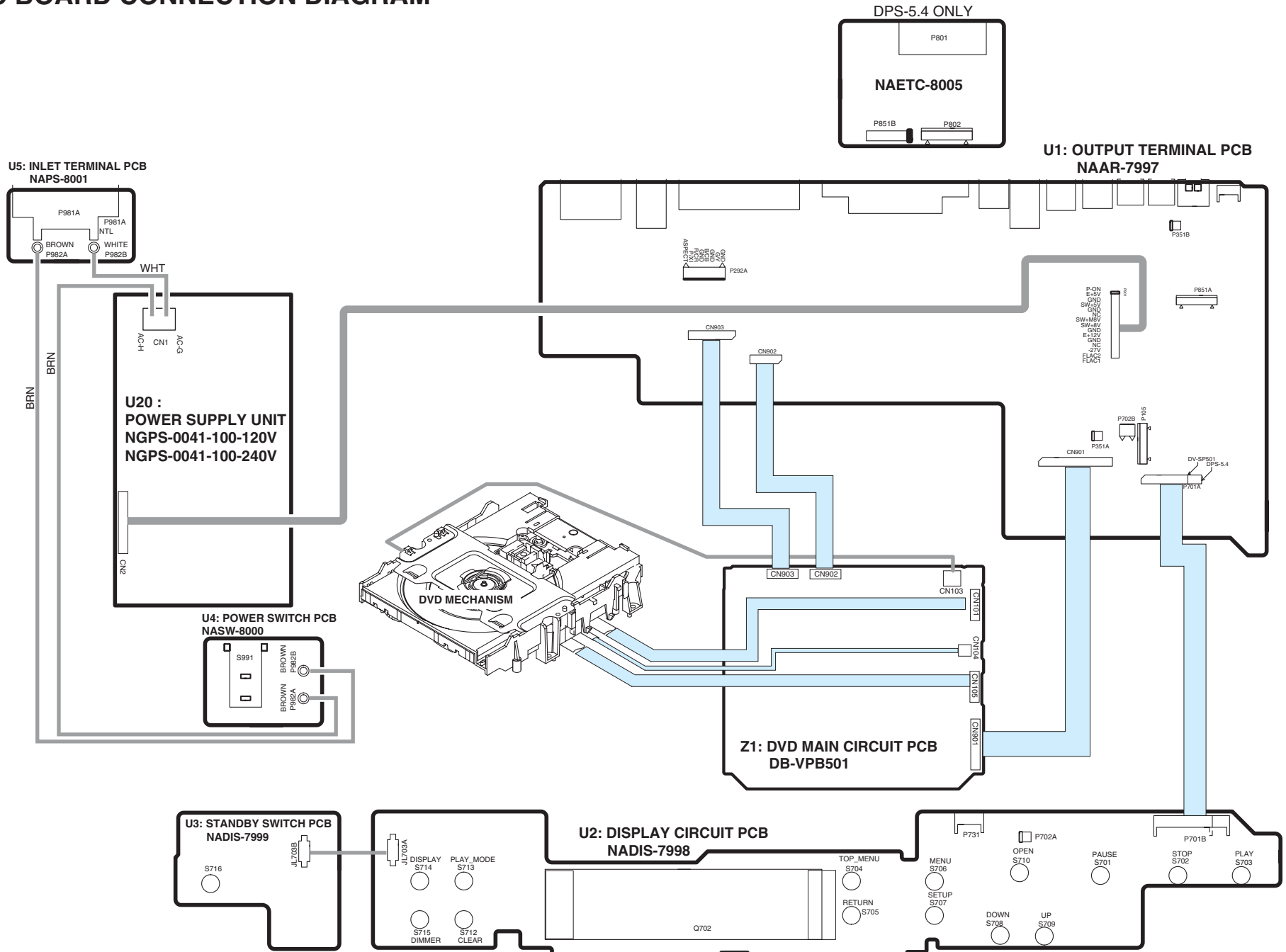

E

F

G

H

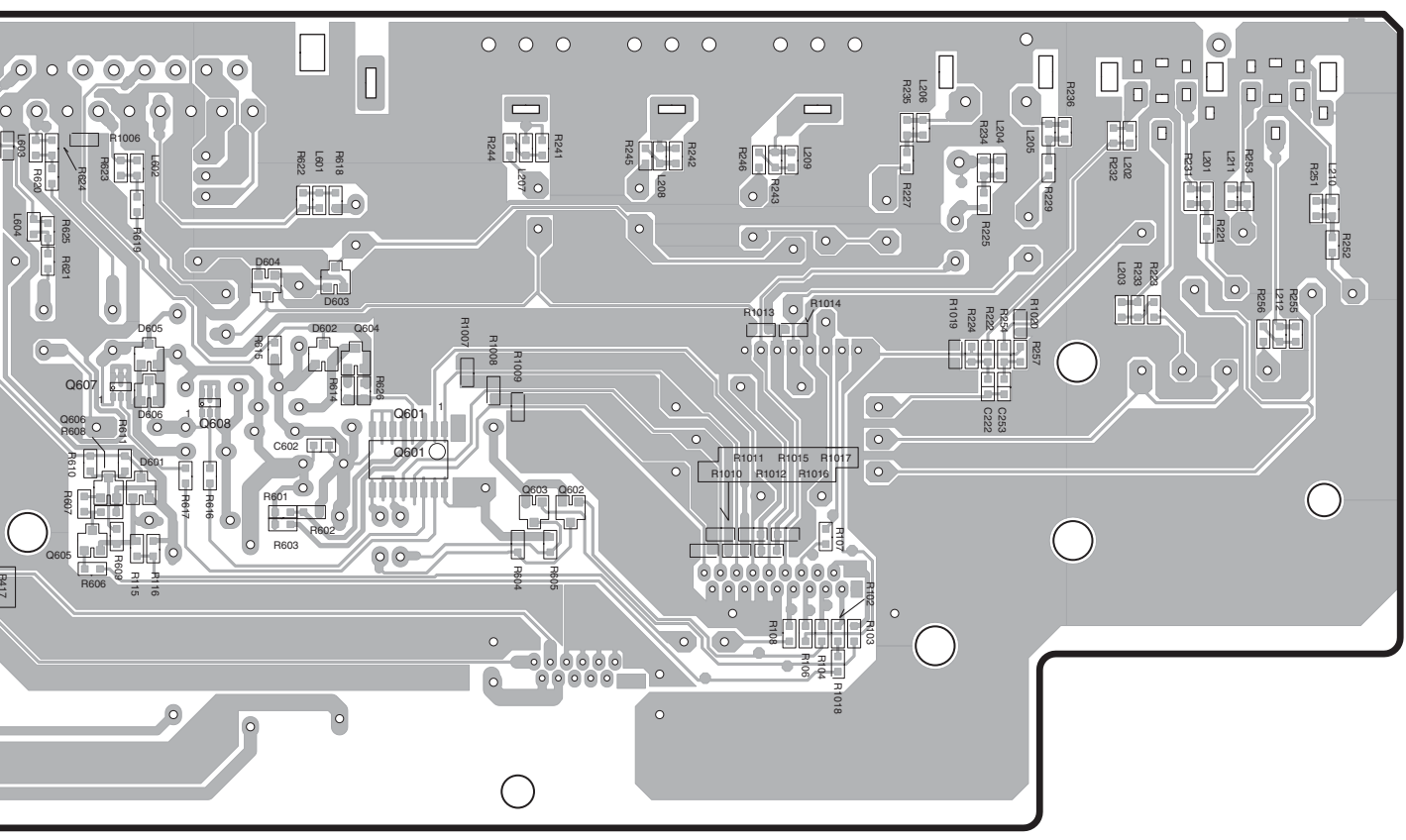

A

B

C

D

PRINTED CIRCUIT BOARD FROM SOLDERING SIDE VIEW

U1: OUTPUT TERMINAL PC BOARD NAAR-7997

1

2

3

4

5

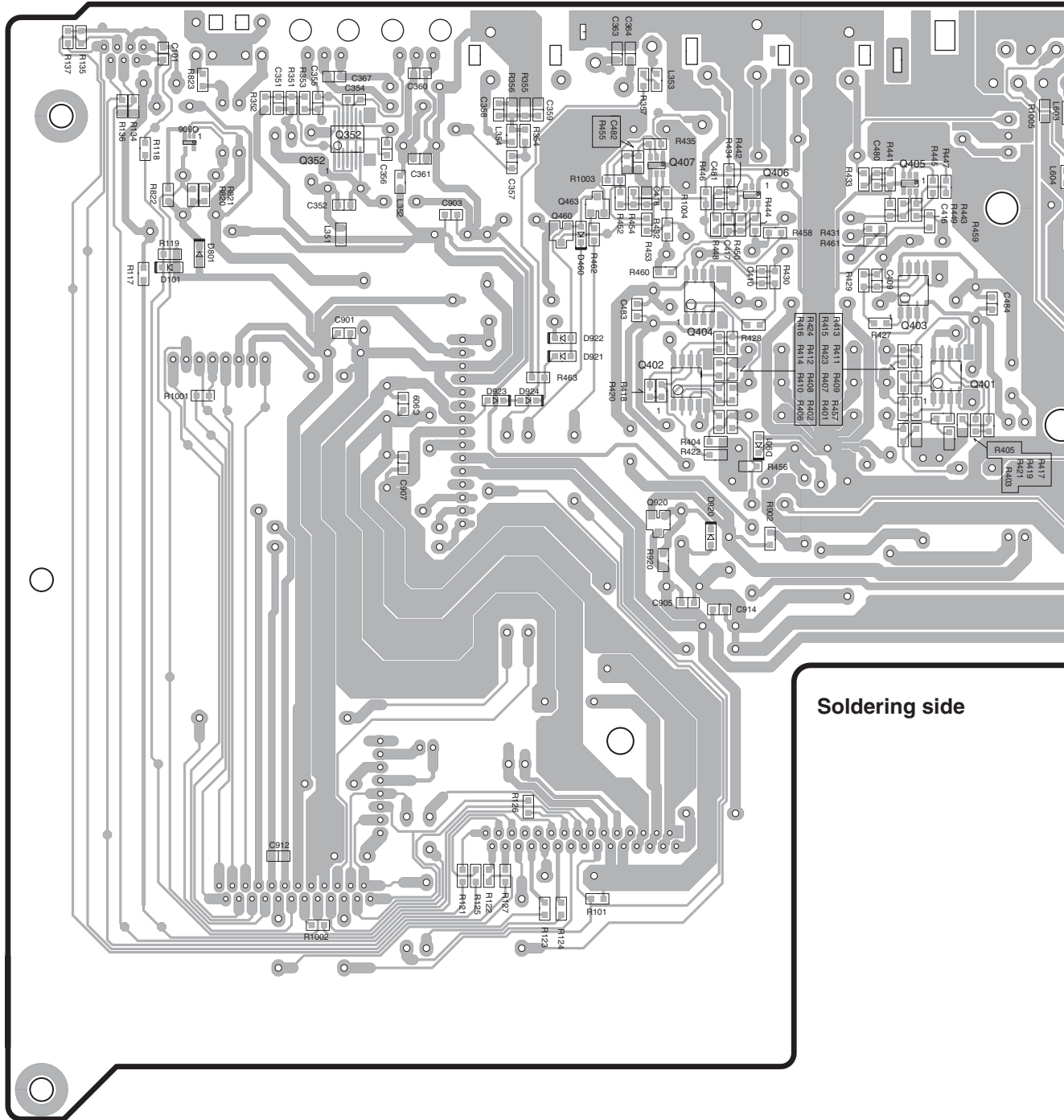

Soldering side

A B C D E F G H

PRINTED CIRCUIT BOARD FROM SOLDERING SIDE VIEW

U1: OUTPUT TERMINAL PC BOARD NAAR-7997

1

2

3

4

5

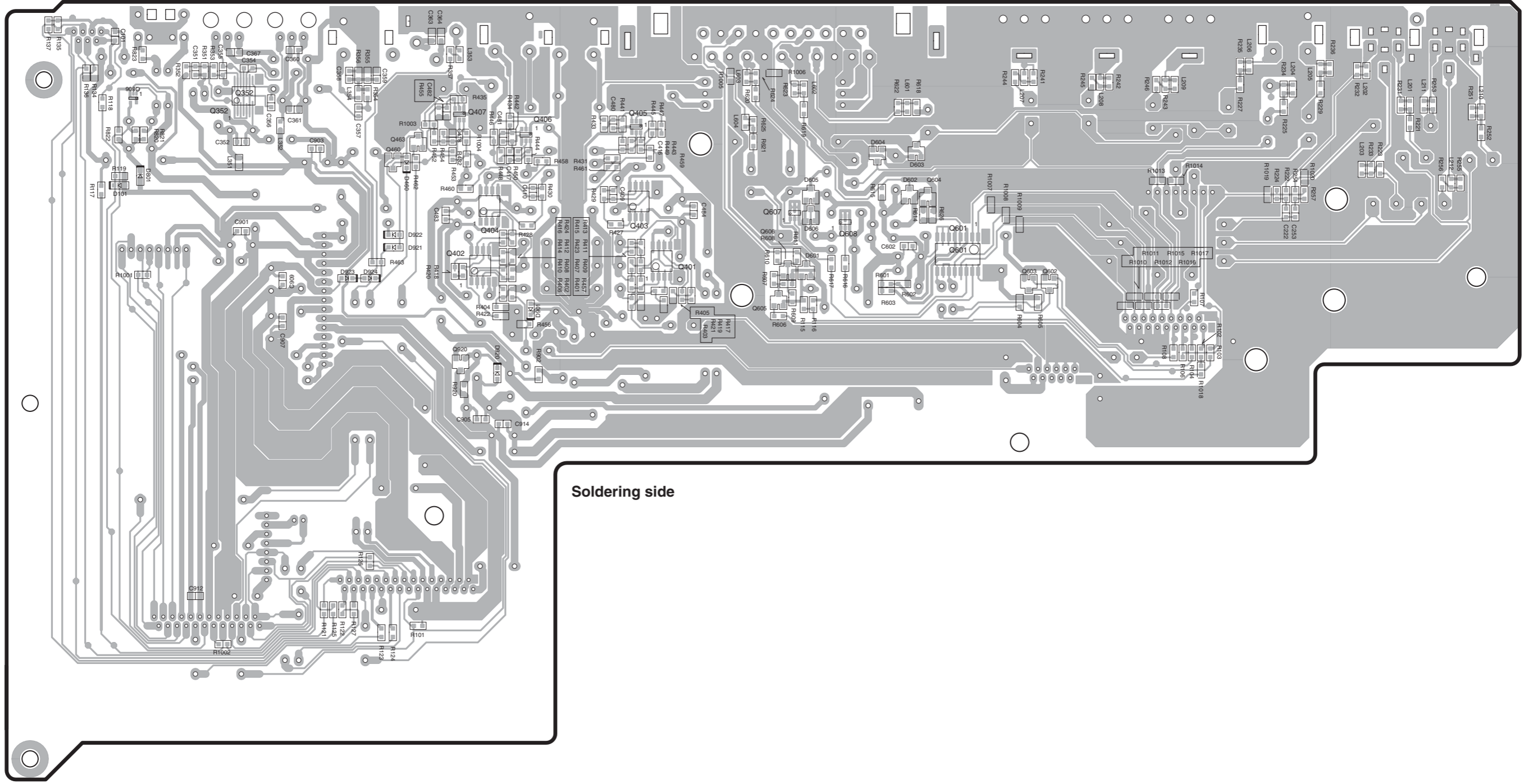

Soldering side

E

F

G

H

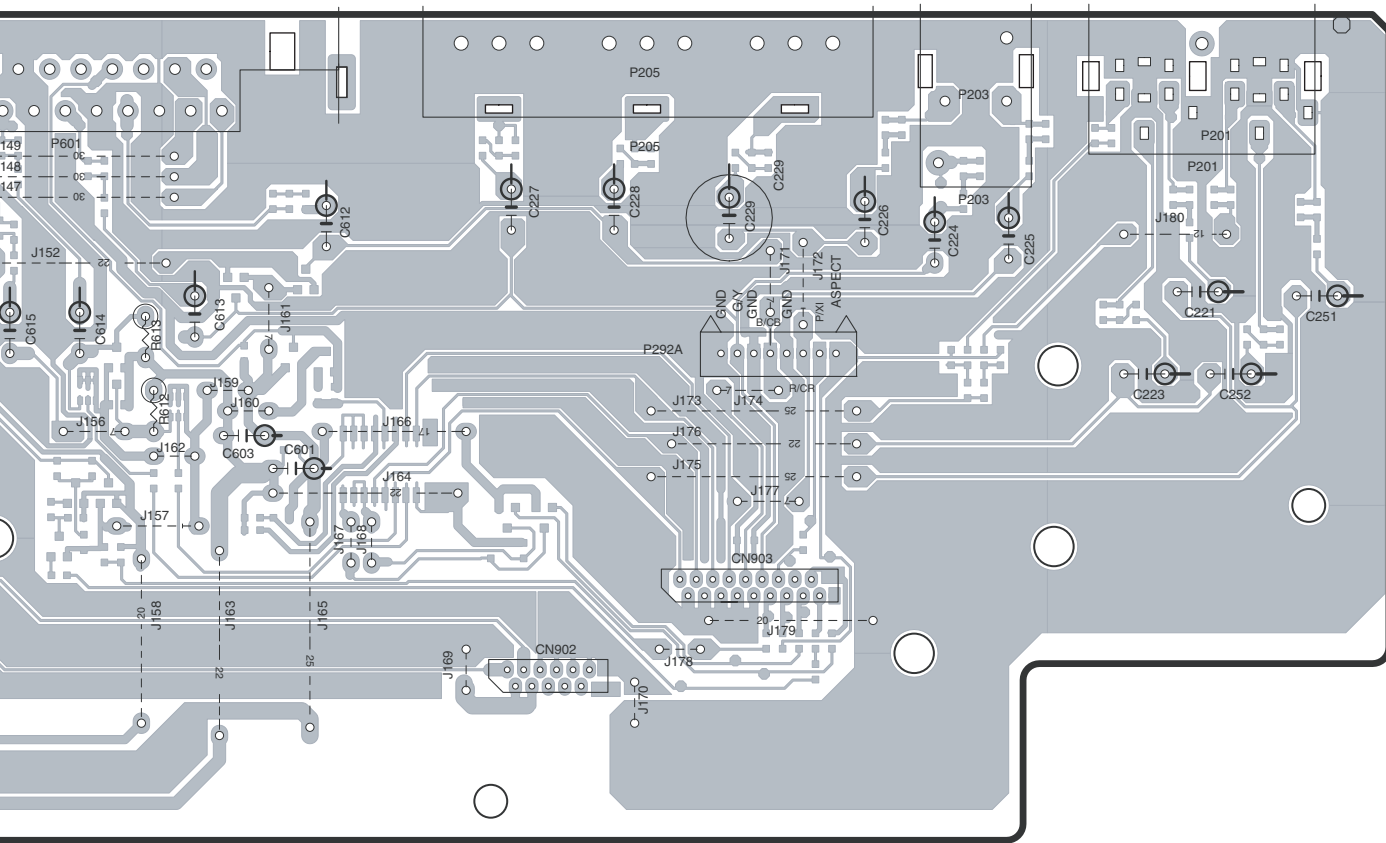

A

B

C

D

PRINTED CIRCUIT BOARD FROM SOLDERING SIDE VIEW

U1 : OUTPUT TERMINAL PC BOARD NAAR-7997

1

2

3

4

5

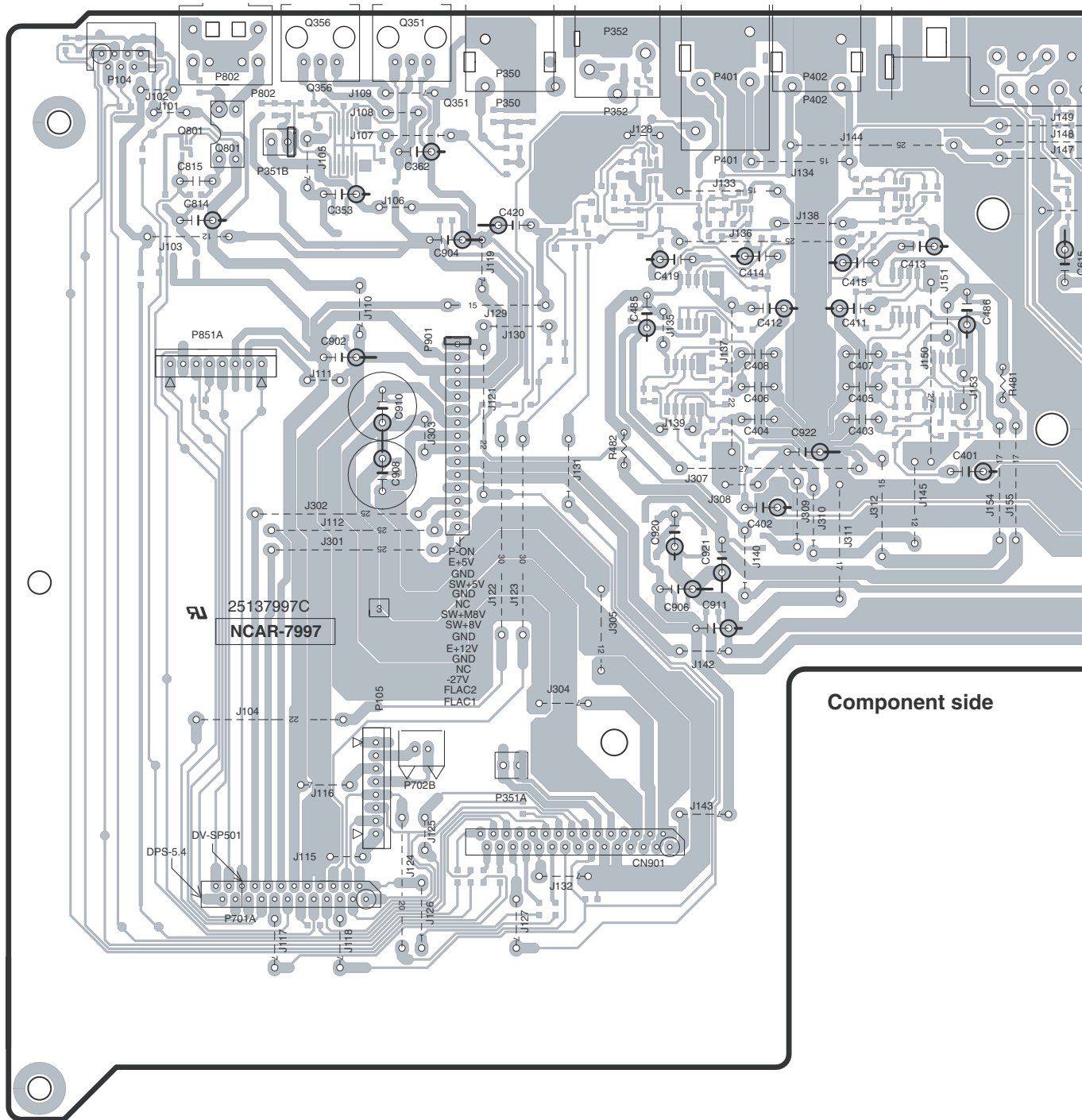

Component side

A B C D E F G H

PRINTED CIRCUIT BOARD FROM SOLDERING SIDE VIEW

U1 : OUTPUT TERMINAL PC BOARD NAAR-7997

1

2

3

4

5

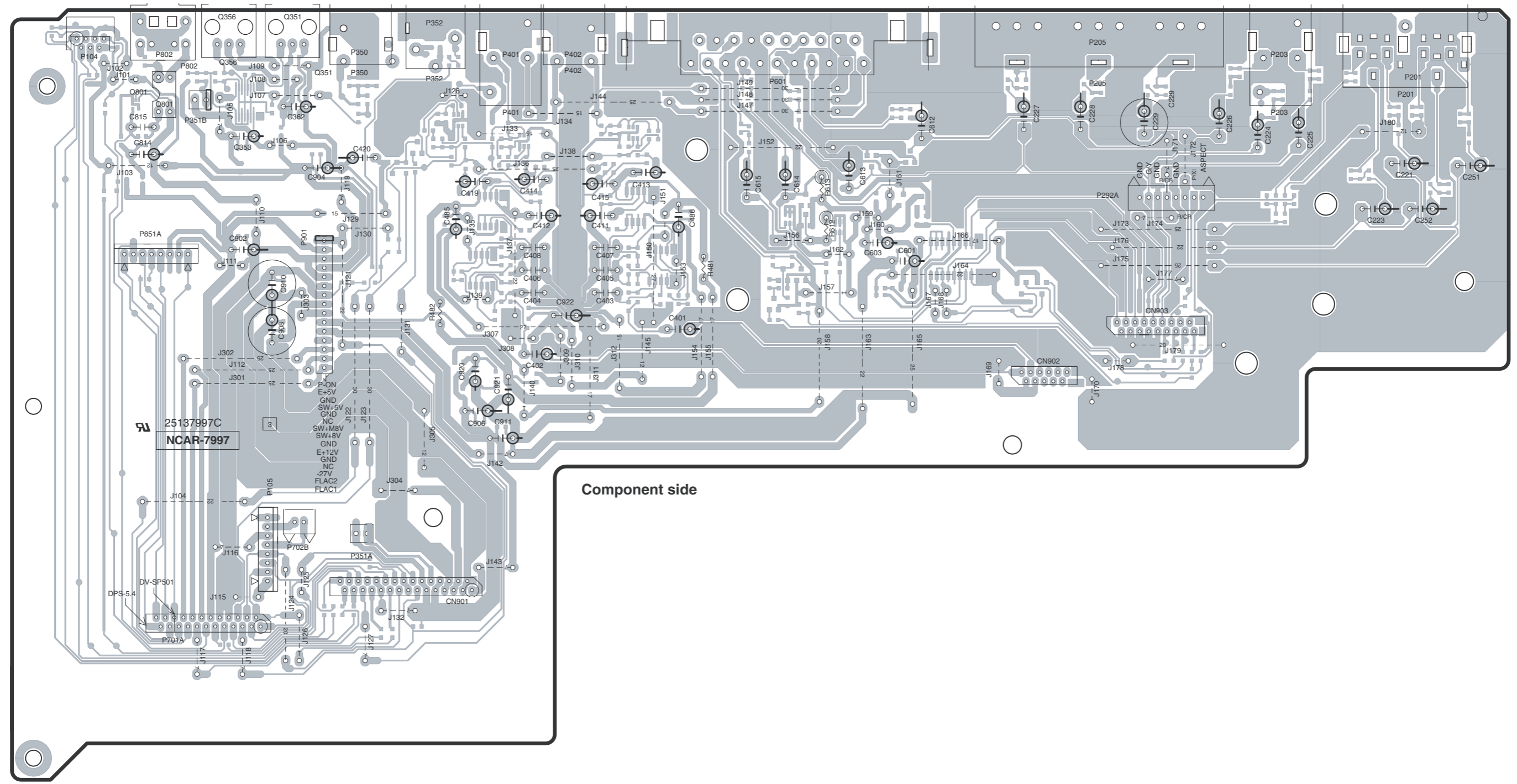

A

B

C

D

PRINTED CIRCUIT BOARD FROM BOTTOM VIEW

1

U3: STANDBY SWITCH PC BOARD NADIS-7999

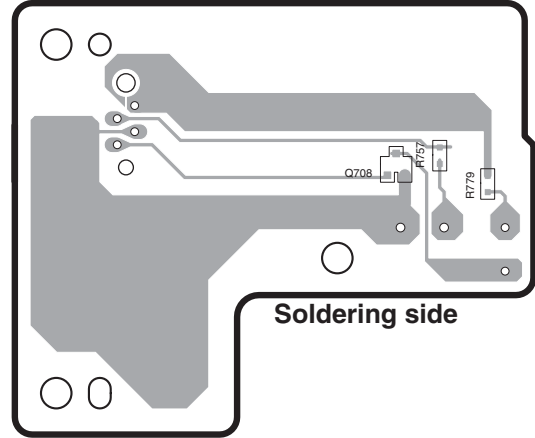
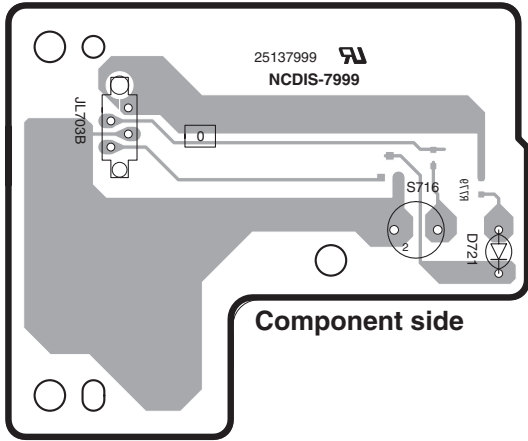

2

3

U4: POWER SWITCH PC BOARD NASW-8000

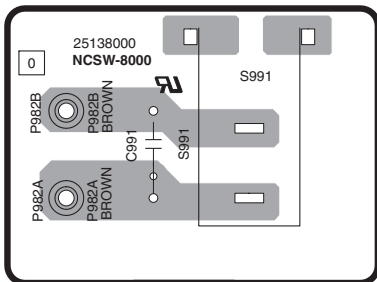

U5: INLET TERMINAL PC BOARD NAPS-8001

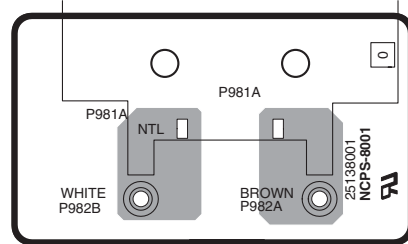

4

5

PRINTED CIRCUIT BOARD FROM SOLDERING SIDE VIEW

U2: DISPLAY CIRCUIT PC BOARD NADIS-7998

1

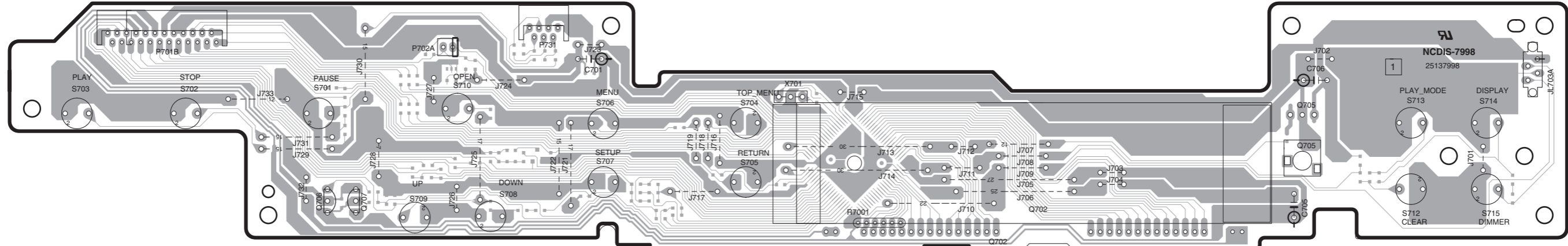

Component side

3

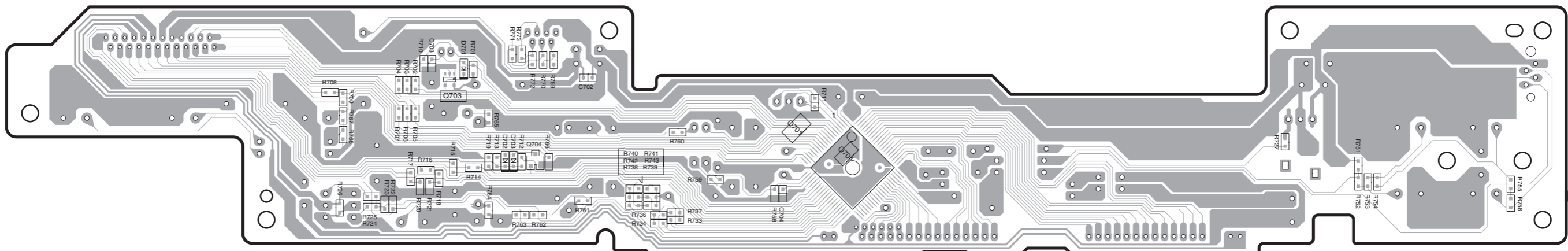

Soldering side

5

A

B

C

D

PRINTED CIRCUIT BOARD FROM SOLDERING SIDE VIEW

U2: DISPLAY CIRCUIT PC BOARD NADIS-7998

1

2

3

4

5

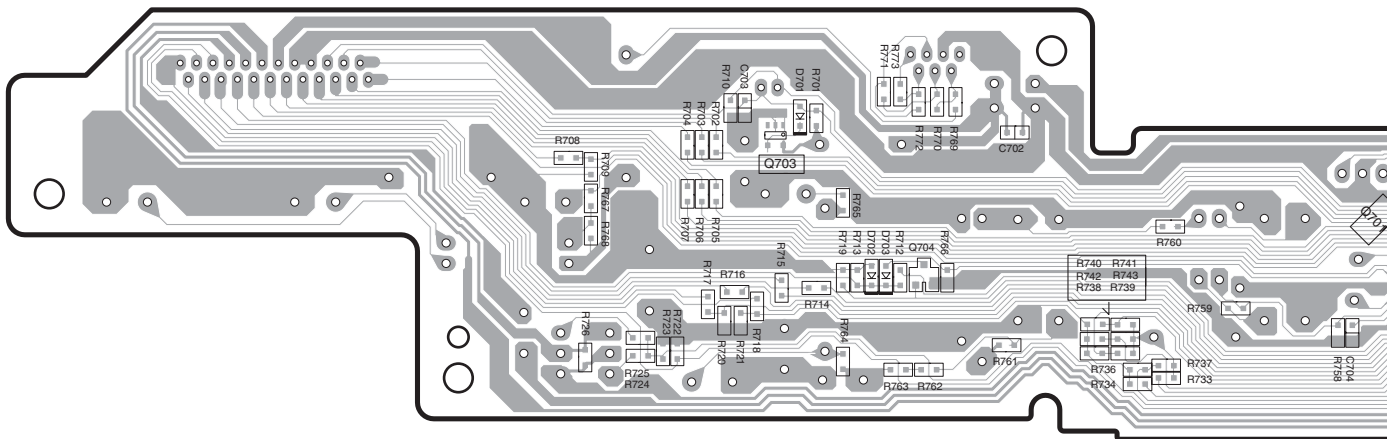
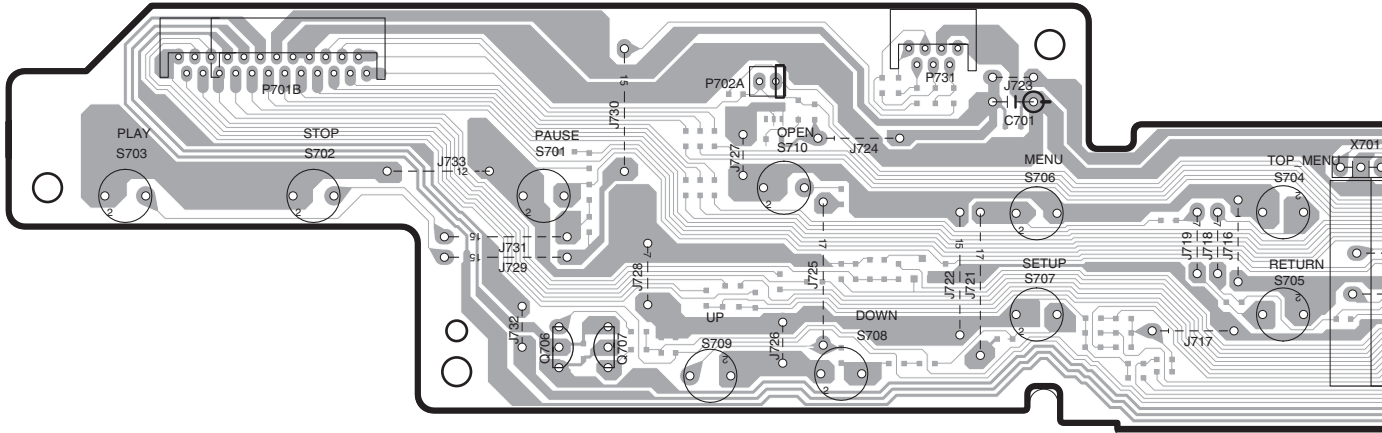

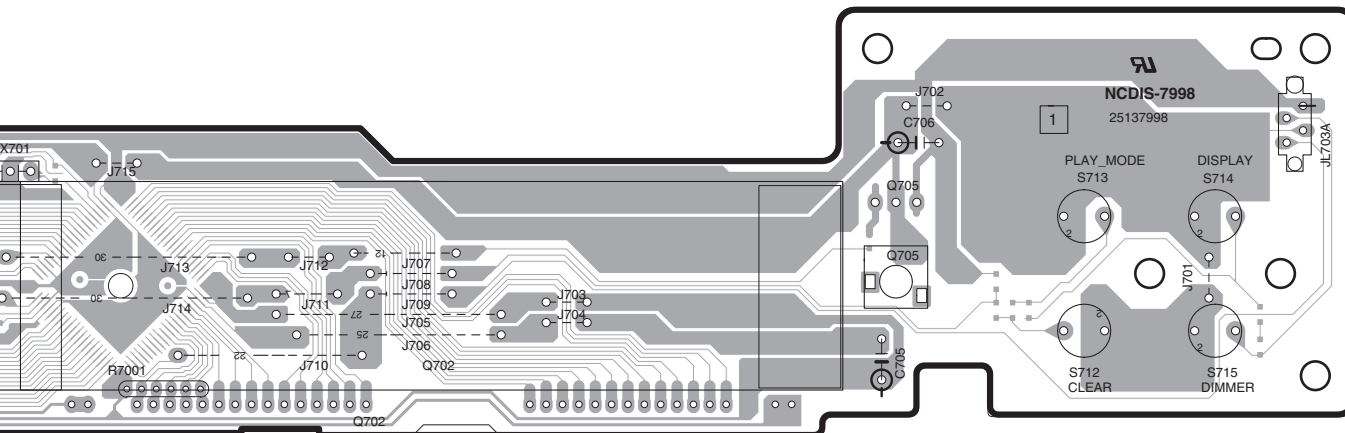

Component side

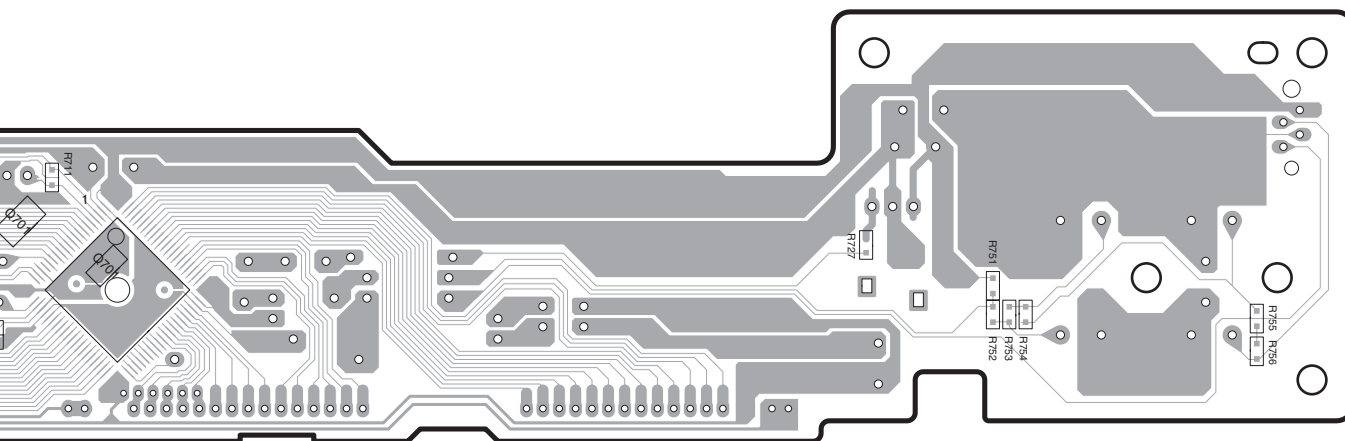

Soldering side

PRINTED CIRCUIT BOARD VIEW

LOAD ASSY

SIDE A

SIDE B

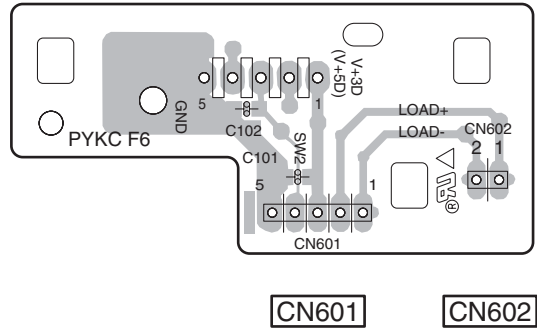
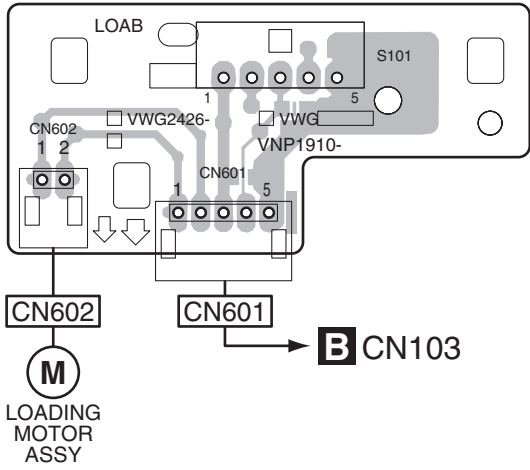

PRINTED CIRCUIT BOARD VIEW
DVD MAIN CIRCUIT PC BOARD (DB-VPB501/XJ)

1 **SIDE A**

SIDE A

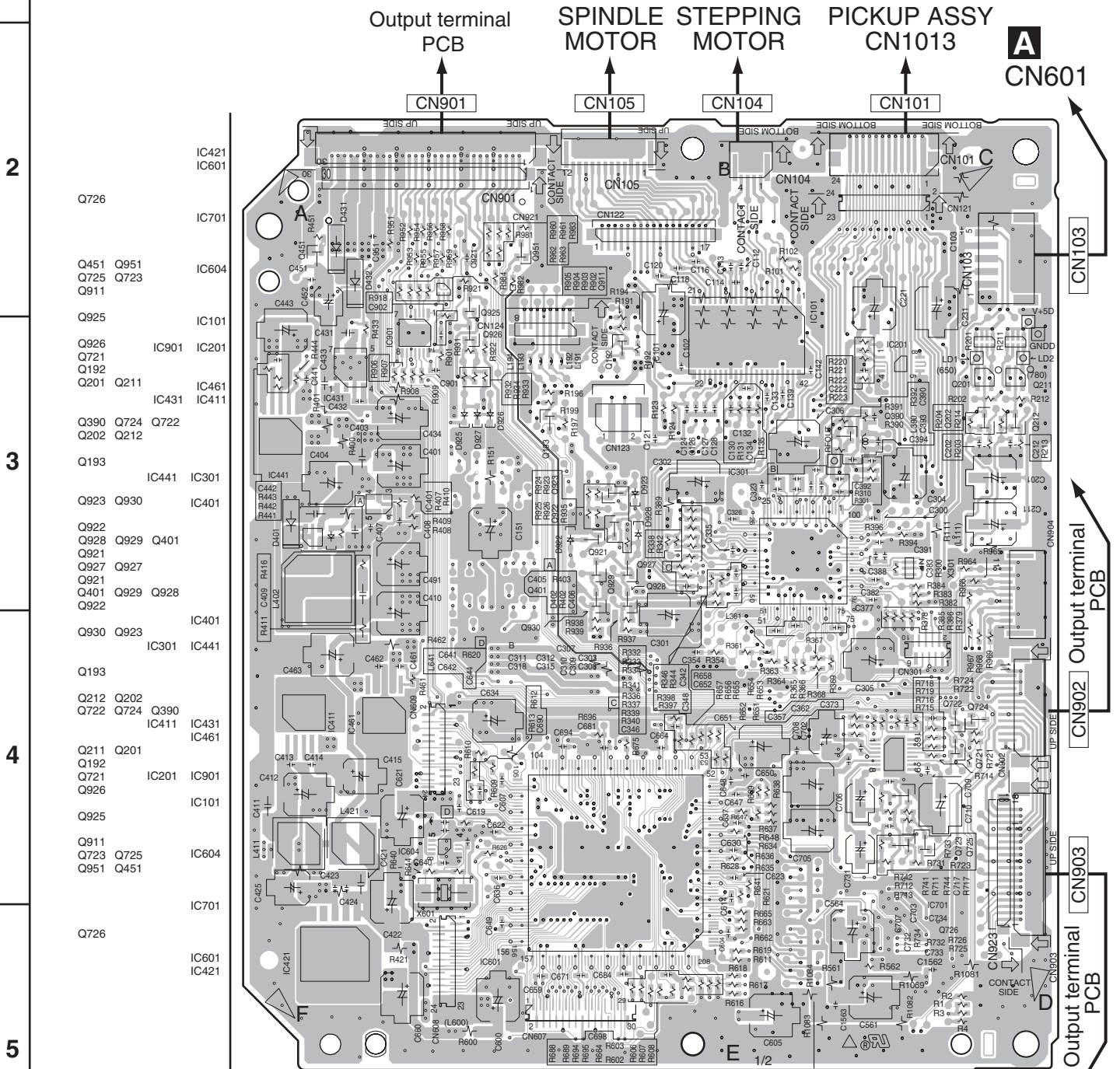

(ANP7463-B)

A

B

C

D

PRINTED CIRCUIT BOARD VIEW
DVD MAIN CIRCUIT PC BOARD (DB-VPB501/XJ)

SIDE B

SIDE B

1

2

3

4

5

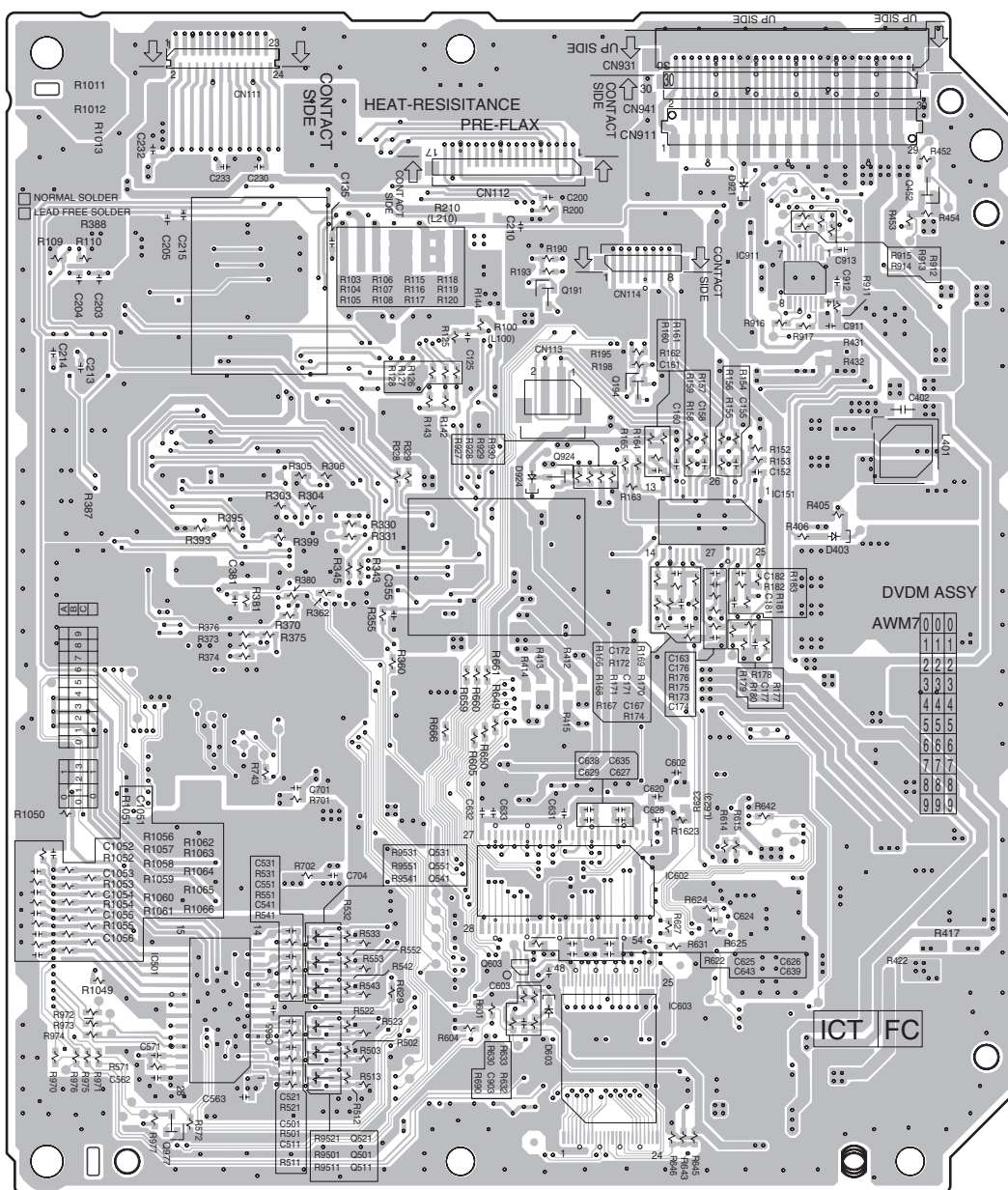

IC603

Q603 Q452 IC501

Q541 IC602 IC911 Q551 Q531 Q191

Q194

Q924

IC151

IC151

Q924

Q194

Q191 Q531 Q551 Q541 IC911 IC602

IC501 Q452 Q603

IC603

Q977 Q521 Q501 Q511

IC BLOCK DIAGRAM / TERMINAL DESCRIPTION

Q532 : TC74VHC04FT Hex inverter

Pin layout

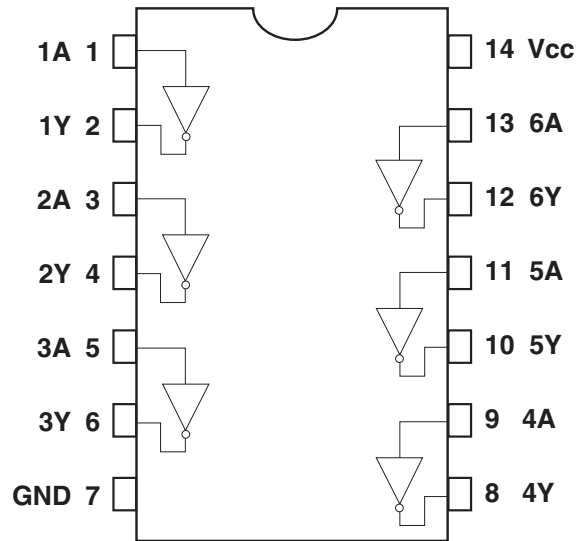

Truth table

A	Y
L	H
H	L

IC BLOCK DIAGRAM/ TERMINAL DESCRIPTION

Q601 : TC4053B TRIPLE 2 - CHANNEL MULTIPLEXER / DEMULTIPLEXER

PIN LAYOUT

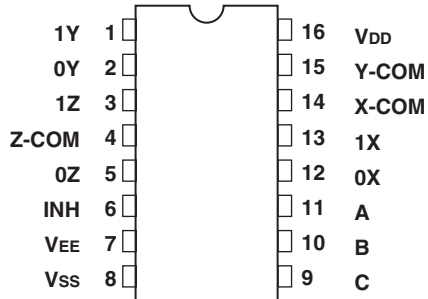

TRUTH TABLE

CONTROL INPUTS			"ON" CHANNEL
INHIBIT	B	A	
L	L	L	0X, 0Y, 0Z
L	L	H	1X, 0Y, 0Z
L	H	L	0X, 1Y, 0Z
L	H	H	1X, 1Y, 0Z
L	L	L	0X, 0Y, 1Z
L	L	H	1X, 0Y, 1Z
L	H	L	0X, 1Y, 1Z
L	H	H	1X, 1Y, 1Z
H	☆	☆	NONE

☆ : Don't Care

LOGIC DIAGRAM

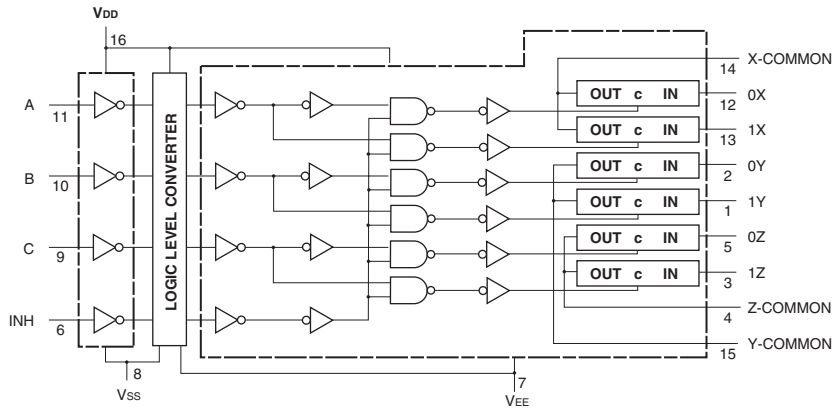

TRUTH TABLE

CONTROL	Impedance Between IN-OUT*
C	
H	$0.5 \sim 5 \times 10^2 \text{ ohm}$
L	$> 10^8 \text{ ohm}$

* See Electrical Characteristics

IC BLOCK DIAGRAM / TERMINAL DESCRIPTION

IC301 : STM6316ATXXA FRONT END IC

Block Diagram

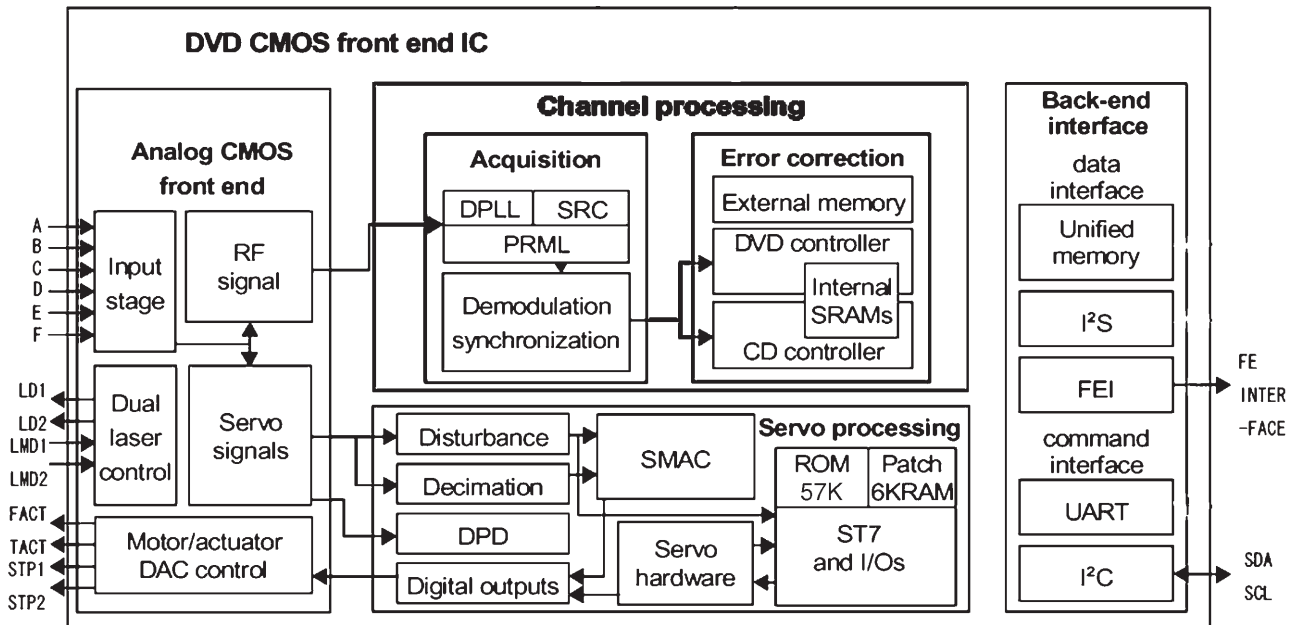

IC BLOCK DIAGRAM / TERMINAL DESCRIPTION

IC301 : STM6316AT

No.	PIN name	description	detail
1	IREF	12.7k	Analog block reference part
2	GNDAI	GND	analog gnd
3	RFIN	capacitor	RF signal C association input to a demodulation block
4	RFOUT	capacitor	B1+B2+B3+B4 mixture listing from an analog block
5	VCCA18	1V8	analog 1V
6	A	B1	PU - B1 input
7	GNDMN	GND	analog gnd
8	B	B2	PU - B2 input
9	VCC33MN	3V3	analog 3V
10	REFD	to pick up	2V1 output for PU
11	VCC18MN	1V8	analog 1V
12	D	B4	PU - B4 input
13	VCCA18IS	1V8	analog 1V
14	C	B3	PU - B3 input
15	VCCA33IS	3V3	analog 3V
16	GNDAIS	GND	analog gnd
17	VCC33SD	3V3	analog 3V
18	VCC18SD	1V8	analog 1V
19	GNDSD	GND	analog gnd
20	F	C	PU-3 beam C input
21	E	A	PU-3 beam A input
22	VSHIELDIS	GND	analog gnd
23	VCC18ADC	1V8	analog 1V
24	GNDADC	GND	analog gnd
25	VSHIELDADC	GND	analog gnd
26	VCC33DAC	3V3	analog 3V
27	GNDDAC	GND	analog gnd
28	SPINDLE	560ohm(st2)	DAC current listing for stepper drive
29	SLEDGE	560ohm(st1)	DAC current listing for stepper drive
30	REFEXT	20K1	Reference for DAC
31	REFGND	refex	analog gnd
32	REFDAC	560ohm1%	DAC reference
33	FACT	560ohm1%	DAC current listing for focus
34	TACT	560ohm1%	DAC current listing for tracking
35	VCC18DAC	1V8	analog 1V
36	PG0	F	FG pulse input
37	PC1	P	Driver control signal
38	PC2	tray SW1(open)	SW input for tray OPEN position
39	PC3	SI	Driver control signal
40	PC4	SLD position	Inside SW input

IC BLOCK DIAGRAM / TERMINAL DESCRIPTION

IC301 : STM6316AT

No.	PIN name	description	detail
41	VSS	GND	digital gnd
42	VDD33	3V3	digital 3V3
43	PC5	780/X65	780nm/650nmLD change control signal
44	PC6	spinde PD	Control PDM listing for spindle drive
45	PC7	opicgai	OEIC gain control signal
46	PD7	03PU/X02P	Pull-up settlemen
47	VSS	GND	digital gnd
48	VDD18	1V8	digital 1V8
49	PD6	(debug)	test
50	PD5	(debug)	test
51	PD4	(DSPclk)	test
52	PD3	(DSPdata)	test
53	PD2	(DSPstrb1)	test
54	PD1	error monitor	Terminal for TRKG error monitor (30KHzLPF add need)
55	PD0	tray PDM drive	Control PDM signal for tray drive
56	VSS	GND	digital gnd
57	VDD33	3V3	digital 3V3
58	OUT_ERR	RS_ERRO	BE DATA I/F
59	OUT_EVALID	RS_ERR_E	BE DATA I/F
60	VSS	GND	digital gnd
61	OUT_CLK	RS_BCL	BE DATA I/F
62	VDD18	1V8	digital 1V8
63	OUT_DVALID	RS_DVALI	BE DATA IF
64	OUT_DATA	RS_DAT	BE DATA I/F
65	OUT_SYNC	RS_ECCBS	BE DATA IF
66	PE5	SCL(DMA)	FE routine download input
67	PE4	SDA(DMA)	FE routine download input
68	PE2	SC	BE command I/F
69	PE2	SD	BE command I/
70	PE1	tray SW2(close)	SW input for tray CLOSE position
71	PE0	DXXIN	FE status propagation signal
72	VSS	GNDD	digital gnd
73	VDD3	3V3	digital 3V3
74	PF1	10K-pullup	Built-in facility setting terminal
75	PF0	10K-pulldown	Built-in facility setting terminal
76	VSS	GND	digital gnd
77	VDD18	1V8	digital 1V8
78	PG1	to EMULATO	Built-in facility setting terminal
79	PG0	to EMULATO	Built-in facility setting terminal
80	TEST	10K-pulldown	test

IC BLOCK DIAGRAM / TERMINAL DESCRIPTION

IC301 : STM6316AT

No.	PIN name	description	detail
81	RESET_N	RESET	RESET input
82	VSSADC	GND	analog gnd
83	VDD18ADC	1V8	analog 1V8
84	GNDPLL	GND	analog gnd
85	PLLOFF	GND	analog gnd
86	FREOUT	20MXtal	SYSTEMCLK oscillating circuit
87	FREIN	20MXtal	SYSTEMCLK oscillating circuit
88	VCC18PLL	1V8	analog 1V8
89	LD1	650nmLD	650nmLD driving signal
90	LD2	780nmLD	780nmLD driving signal
91	VCCA33	3V3	digital 3V3
92	TWSEL	CD_VR/GN	Monitor diodes VR junction terminal for CD
93	LMD1	LMD/LMD	Monitor voltage junction terminal
94	LMD2	DVD_VR/LMD2	Monitor diodes VR junction terminal for DVD
95	GNDL	GND	analog gnd
96	TST_PM	n	tset
97	TST_SLICE	n	test
98	TST_ADC	n	test
99	RFSACD	SACD_I	RF signal output
100	VBGFILT	capacitor	Condenser junction terminal for inside reference stability

IC BLOCK DIAGRAM / TERMINAL DESCRIPTION

IC601 : STM5589CVA BACK END IC

No.	Pin Name	Dir.	Pin Function
1	FP_SO	OUT	Front Panel / DAC interface. Serial transfer data output.
2	A_DATA3	OUT	reserve
3	VCLK	OUT	reserve
4	VDD_3V3	-	3.3 V Power supply
5	VSS	-	Ground
6	BIDATA	OUT	reserve
7	BIBCLK	OUT	reserve
8	BIFLAG	OUT	reserve
9	TRYPOS	OUT	It is not connected except 5 Disc Changer
		IN	Only 5 Disc Changer. Tray rotation pulse input. CAPTURE_IN0 can be used.
10	SQUEEZE	OUT	Output signal for S-Video output S1/S2 control. 'H' : squeeze output mode.
11	RTS	OUT	UART(RS-232C) Request To Send signal output
12	LETTER	OUT	Output signal for S-Video output S1/S2 control & EURO(SCART) connector (FUNCTION SWITCHING) signal. 'H' : letter-box output mode.
13	CTS	IN	UART(RS-232C) Clear To Send signal input
14	VDD_1V8	-	1.8 V Power supply
15	VSS	-	Ground
16	FE_DATA	IN	Front-End L6316 stream interface. Serial data input.
17	FE_BCLK	IN	Front-End L6316 stream interface. Serial clock input.
18	FE_DVALID	IN	Front-End L6316 stream interface. Data valid flag input.
19	FE_SYNC	IN	Front-End L6316 stream interface. Serial synchronize flag input.
20	FE_EVALID	IN	Front-End L6316 stream interface. Error valid flag for RS_split.
21	FE_ECCBST	IN	Front-End L6316 stream interface. ECC block start flag for RS_split.
22	I/XP	OUT	Output signal for a change of interlace/Progressive output for video driver. 'L' : progressive 'H' : interlace
23	VDD_RGB	-	RGB circuit 3.3 V Power supply
24	VSS_RGB	-	RGB circuit Ground
25	B_OUT	OUT	B / Cb
26	G_OUT	OUT	G / Y
27	R_OUT	OUT	R / Cr
28	VREF_RGB	IN	RGB DAC reference
29	IREF_RGB	IN	RGB DAC current reference
30	VDD_YCC	-	YC circuit 3.3 V Power supply
31	VSS_YCC	-	YC circuit Ground
32	Y_OUT	OUT	Y
33	C_OUT	OUT	C
34	CV_OUT	OUT	CV
35	VREF_YCC	IN	YCC DAC reference
36	IREF_YCC	IN	YCC DAC current reference
37	VDD_1V8	-	1.8 V Power supply
38	VSS	-	Ground

IC BLOCK DIAGRAM / TERMINAL DESCRIPTION

IC601 : STM5589CVA BACK END IC

No.	Pin Name	Dir.	Pin Function
39	XDRVMUTE	OU	It is not connected except 5 Disc Changer. Only 5 Disc Changer. Output signal for motor driver muting. 'L' : muting
40	OPEN	OUT	It is not connected except 5 Disc Changer
		IN	Only 5 Disc Changer. Input signal for tray position. 'H' : complete OPEN position.
41	CLOSE	OUT	It is not connected except 5 Disc Changer
		IN	Only 5 Disc Changer. Input signal for tray position. 'H' : complete CLOSE position.
42	CLAMP	OUT	It is not connected except 5 Disc Changer
		IN	Only 5 Disc Changer. Input signal for showing disc clamp position. 'H' : complete disc clamp position.
43	UNCLAMP	OUT	It is not connected except 5 Disc Changer
		IN	Only 5 Disc Changer. Input signal for showing disc un-clamp position. 'H' : complete disc clamp position.
44	DISC_SNS	OUT	It is not connected except 5 Disc Changer
		IN	Only 5 Disc Changer. Input signal for disc existing. 'L' : existing
45	XDRVMUTE2	OUT	reserved
46	TP-x	OUT	reserved
47	VDD_3V3	-	3.3 V Power supply
48	VDD_PCM	-	1.8 V Power supply
49	VSS_PCM	-	Ground
50	VSS	-	Ground
51	A_BCK	OUT	Audio DAC clock
52	A_DATA0	OUT	Audio DAC Front L,R data
53	A_DATA1	OUT	reserved
54	A_DATA2	OUT	reserved
55	A_MCLK	OUT	Audio DAC Master clock
56	A_LRCK	OUT	Audio DAC L/R clock
57	A_DOUT	OUT	S/PDIF(IEC60958) digital audio output
58	SMI_A4	OUT	SMI SDRAM Address
59	SMI_A5		
60	SMI_A6		
61	SMI_A7		
62	SMI_A8		
63	SMI_A9		
64	VDD_1V8	-	1.8 V Power supply
65	VSS	-	Ground
66	SMI_A3	OUT	SMI SDRAM Address
67	SMI_A2		
68	SMI_A1		
69	SMI_A0		
70	SMI_A10		
71	SMI_A11		
72	SMI_A12		
73	SMI_A13		

IC BLOCK DIAGRAM / TERMINAL DESCRIPTION

IC601 : STM5589CVA BACK END IC

No.	Pin Name	Dir.	Pin Function
74	SMI_CS0	OUT	SMI SDRAM chip select 'L'
75	SMI_CS1	OUT	reserve
76	SMI_RAS	OUT	SMI SDRAM RAS 'L'
77	SMI_CAS	OUT	SMI SDRAM CAS 'L'
78	SMI_WE	OUT	SMI SDRAM Write Enable 'L'
79	SMI_DQML	OUT	SMI SDRAM Lower DQM 'L': Lower select
80	SMI_DQMU	OUT	SMI SDRAM Upper DQM 'L': Upper select
81	VDD_3V3	-	3.3 V Power supply
82	SMI_CLKIN	IN	External SDRAM clock input
83	VSS	-	Ground
84	SMI_D0	I/O	SMI SDRAM Data
85	SMI_D1		
86	SMI_D2		
87	SMI_D3		
88	SMI_D4		
89	SMI_D5		
90	SMI_D6		
91	SMI_D7		
92	SMI_D8		
93	SMI_D9		
94	VDD_1V8	-	1.8 V Power supply
95	SMI_CLKOUT	OUT	SDRAM clock output
96	VSS	-	Ground
97	SMI_D10	I/O	SMI SDRAM Data
98	SMI_D11		
99	SMI_D12		
100	SMI_D13		
101	SMI_D14		
102	SMI_D15		
103	TRACK_CROSS	OUT	reserved
104	DSD_XPCM	OUT	reserved
105	DAC_XRST	OUT	reserved
106	ADC_PCMCLK	OUT	reserved
107	VDD_3V3	-	3.3 V Power supply
108	VSS	-	Ground
109	XTRST	IN	Diagnostic Control Unit interface
110	TMS	IN	Diagnostic Control Unit interface
111	TDO	OUT	Diagnostic Control Unit interface
112	TDI	IN	Diagnostic Control Unit interface
113	TCK	IN	Diagnostic Control Unit interface
114	ROTDRV	OUT	Only 5 disc changer. PWM output for tray rotation.
115	BOOT_FROM_ROM	IN	Boot select 'L' : Boot from DCU. 'H' : Boot form ROM.
116	LOAD_DRV	OUT	Only 5 disc changer. PWM output for tray Open/Close drive.
117	CPU_OE	OUT	OE signal for 16M bits FLASH memory for firmware. 'L': enable

IC BLOCK DIAGRAM / TERMINAL DESCRIPTION

IC601 : STM5589CVA BACK END IC

No.	Pin Name	Dir.	Pin Function
118	CPU_SDCK	OUT	CLOCK for 64M bits SDRAM for debugging firmware
119	VDD_1V8	-	1.8 V Power supply
120	PIXCLK	IN	Master 27MHz system clock input
121	VSS	-	Ground
122	VDD_PLL	-	Clock PLL circuit 1.8 V Power supply
123	VSS_PLL	-	Clock PLL circuit Ground
124	XRESET	IN	Power ON system RESET signal. 'L': reset
125	SACD_IRQ	IN	reserved
126	FP_XRDY	IN	Front Panel interface. Hand-shake input.
127	FE_INT	IN	Interrupt input signal from Front-End L6316
128	F_XWE, SD_DQML	OUT	Flash memory write enable. Debug SDRAM/SRAM Lower DQM. 'L': enable, Lower select.
129	SD_DQMU	OUT	Debug SDRAM/SRAM Upper DQM 'L':upper select
130	SD_RXW	OUT	Debug SDRAM Read/Write 'L':write, 'H':read
131	CPU_WAIT	IN	CPU wait 'H' input
132	CE_FLASH	OUT	Flash memory Chip Enable 'L'
133	CPU_CE2	OUT	reserved
134	CPU_CE1	OUT	reserved
135	SD_XRAS	OUT	Debug SDRAM RAS 'L' Debug SRAM chip enable 'L'
136	VDD_3V3	-	3.3 V Power supply
137	VSS	-	Ground
138	CPU_RAS1	OUT	reserved
139	SD_XCAS	OUT	Debug SDRAM CAS 'L'
140	SD_XCS	OUT	Debug SDRAM Chip Select 'L'
141	CPU_D0	I/O	FLASH, Debug SDRAM/SRAM data
142	CPU_D1		
143	CPU_D2		
144	CPU_D3		
145	CPU_D4		
146	CPU_D5		
147	CPU_D6		
148	CPU_D7		
149	VDD_1V8	-	1.8 V Power supply
150	VSS	-	Ground
151	CPU_D8	I/O	FLASH, Debug SDRAM/SRAM data
152	CPU_D9		
153	CPU_D10		
154	CPU_D11		
155	CPU_D12		
156	CPU_D13		
157	CPU_D14		
158	CPU_D15		
159	VDD_3V3	-	3.3 V Power supply
160	VSS	-	Ground

IC BLOCK DIAGRAM / TERMINAL DESCRIPTION

IC601 : STM5589CVA BACK END IC

No.	Pin Name	Dir.	Pin Function
161	CPU_A1	OUT	FLASH, Debug SDRAM/SRAM Address
162	CPU_A2		
163	CPU_A3		
164	CPU_A4		
165	CPU_A5		
166	CPU_A6		
167	CPU_A7		
168	CPU_A8		
169	CPU_A9		
170	CPU_A10		
171	VDD_1V8	-	1.8 V Power supply
172	VSS	-	Ground
173	CPU_A11	OUT	FLASH, Debug SDRAM/SRAM Address
174	CPU_A12		
175	CPU_A13		
176	CPU_A14		
177	CPU_A15		
178	CPU_A16		
179	CPU_A17		
180	CPU_A18		
181	CPU_A19		
182	CPU_A20		
183	CPU_A21		
184	VDD_3V3		3.3 V Power supply
185	VSS		Ground
186	XEXPE	OUT	reserved
187	FE_ERROR	IN	Front-End L6316 stream interface. ECC Error flag
188	VSEL1	OUT	EURO(SCART) connector (BLINKING) output signal 'L' : RGB output disable 'H' : RGB output enable
189	VSEL2	OUT	EURO(SCART) connector V/Y, R/C signal. 'L' : VRGB output = YCGB 'H' : VRGB output = VRGB
190	FE_RST	OUT	Front-End L6316. Hardware reset output. 'L' : reset
191	SACD_XRST	OUT	reserved
192	XMMUTE	OUT	reserved
193	B_SYNC	OUT	reserved
194	SDA	I/O	Front-End L6316 command interface I2C bus serial data line.
195	SCL	OUT	Front-End L6316 command interface I2C bus serial clock line.
196	B_WCLK	OUT	reserved
197	TXD	OUT	UART(RS-232C) data output
198	VDD_1V8	-	1.8 V Power supply
199	VSS	-	Ground
200	RXD	IN	UART(RS-232C) data input

IC BLOCK DIAGRAM / TERMINAL DESCRIPTION**IC601 : STM5589CVA BACK END IC**

No.	Pin Name	Dir.	Pin Function
201	XAMUTE	OUT	Output signal for analog audio output line muting. 'L' : muting
202	TRIGIN	IN	Diagnostic Control Unit interface
203	TRIGOUT	OUT	Diagnostic Control Unit interface
204	DAC_XCS0	OUT	Chip enable for audio DAC serial control. 'L' : enable
205	DAC_XCS1	OUT	reserved
206	FP_ACK	OUT	Front Panel / DAC interface. Hand-shake (acknowledge) output 'H'.
207	FP_SCK	OUT	Front Panel / DAC interface. Serial transfer clock output.
208	FP_SI	IN	Front Panel interface. Serial transfer data input.

IC BLOCK DIAGRAM / TERMINAL DESCRIPTION

IC101 : M63018FP (BTL DRIVER)-1

Pin Arrangement

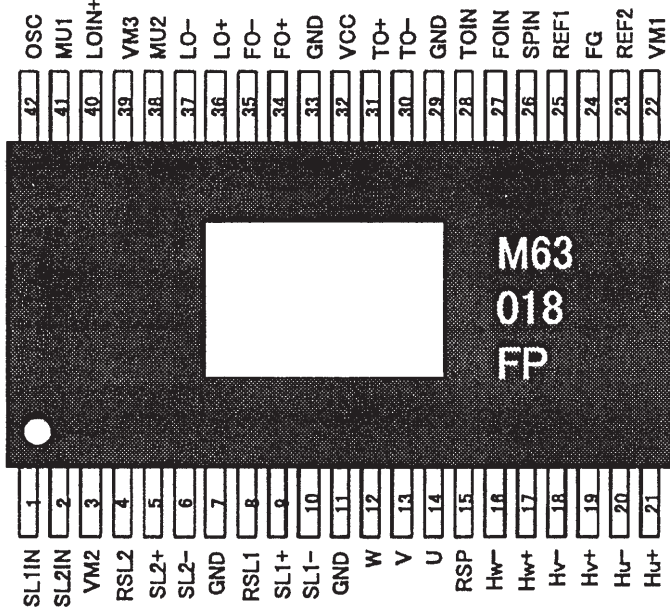

Block Diagram

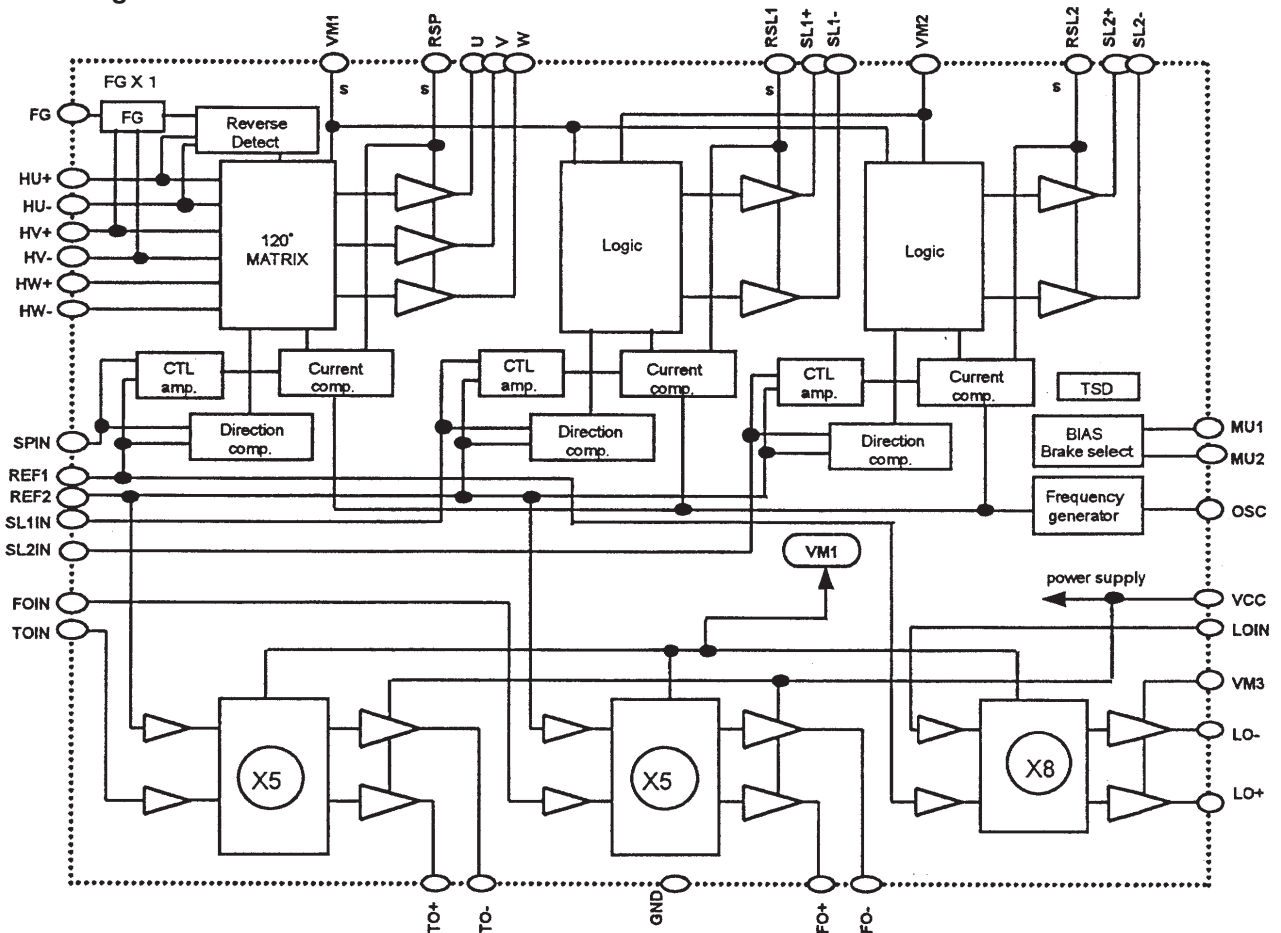

IC BLOCK DIAGRAM / TERMINAL DESCRIPTION

IC101 : M63018FP (BTL DRIVER)-2

Pin Function

TERMINAL	SYMBOL	TERMINAL FUNCTION	TERMINAL	SYMBOL	TERMINAL FUNCTION
1	SL1IN	Slide control voltage input 1	4 2	OSC	PWM carrier oscillation set
2	SL2IN	Slide control voltage input 2	4 1	MU1	mute / brake select terminal 1
3	VM2	Motor Power Supply 2 (for Slide)	4 0	LOIN+	Loading control input(+)
4	RSL2	Slide current sense 2	3 9	VM3	Power Supply3 (for Loading)
5	SL2+	Slide non-inverted output 2	3 8	MU2	mute / brake select terminal 2
6	SL2-	Slide inverted output 2	3 7	LO-	Loading inverted output
7	GND	GND	3 6	LO+	Loading non-inverted output
8	RSL1	Slide current sense 1	3 5	FO-	Focus inverted output
9	SL1+	Slide non-inverted output 1	3 4	FO+	Focus non-inverted output
1 0	SL1-	Slide inverted output 1	3 3	GND	GND
1 1	GND	GND	3 2	VCC	Power Supply (for FS ,TS)
1 2	W	Motor drive output W	3 1	TO+	Tracking non-inverted output
1 3	V	Motor drive output V	3 0	TO-	Tracking inverted output
1 4	U	Motor drive output U	2 9	GND	GND
1 5	RSP	Spindle current sense	2 8	TOIN	Tracking control voltage input
1 6	HW-	HW- sensor amp. input	2 7	FOIN	Focus control voltage input
1 7	HW+	HW+ sensor amp. input	2 6	SPIN	Spindle control voltage input
1 8	HV-	HV- sensor amp. input	2 5	REF1	Reference voltage input 1 (for Spindle,Loading)
1 9	HV+	HV+ sensor amp. input	2 4	FG	Frequency generator output
2 0	HU-	HU- sensor amp. input	2 3	REF2	Reference voltage input 2 (for Slide,Focus,Tracking)
2 1	HU+	HU+ sensor amp. input	2 2	VM1	Motor Power Supply 1 (for Spindle)

IC BLOCK DIAGRAM/ TERMINAL DESCRIPTION

Q401,Q402,Q403,Q404 NJM4580M-D (2-ch Ope. amp.)

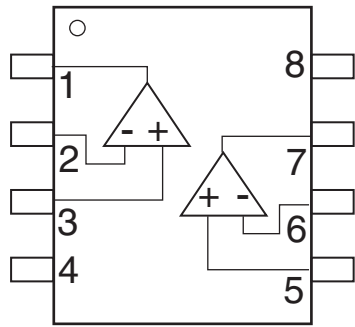

(Top view)

Pin description

1. A OUTPUT
2. A -INPUT
3. A +INPUT
4. V-
5. B +INPUT
6. B -INPUT
7. B OUTPUT
8. V+

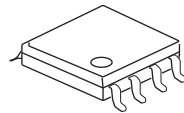

IC BLOCK DIAGRAM/ TERMINAL DESCRIPTION

Q703: S-80130CLMC-JKM VOLTAGE DETECTOR (13.0V CMOS, Active L: out)

Pin Layout

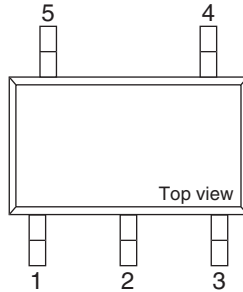

Detection voltage: 3.0V +/-2%
 Delay time: 200ms typ.

Pin Description

No.	Symbol	Description
1	DS	ON/OFF switch for delay time
2	VSS	GND
3	NC *1	Non-connection
4	OUT	Voltage detection output pin
5	VDD	Voltage input pin

*1. NC pin is electrically open.

Block Diagram

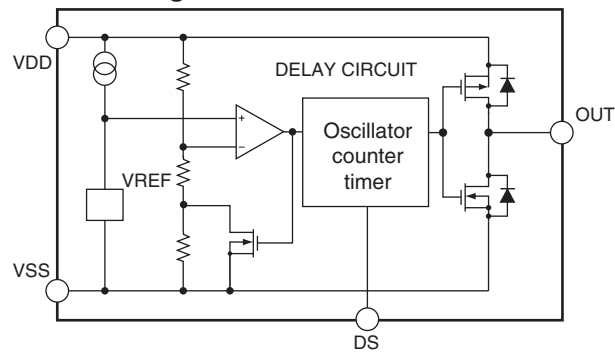

MICROPROCESSOR TERMINAL DESCRIPTION

Q701 : MPD780232GC

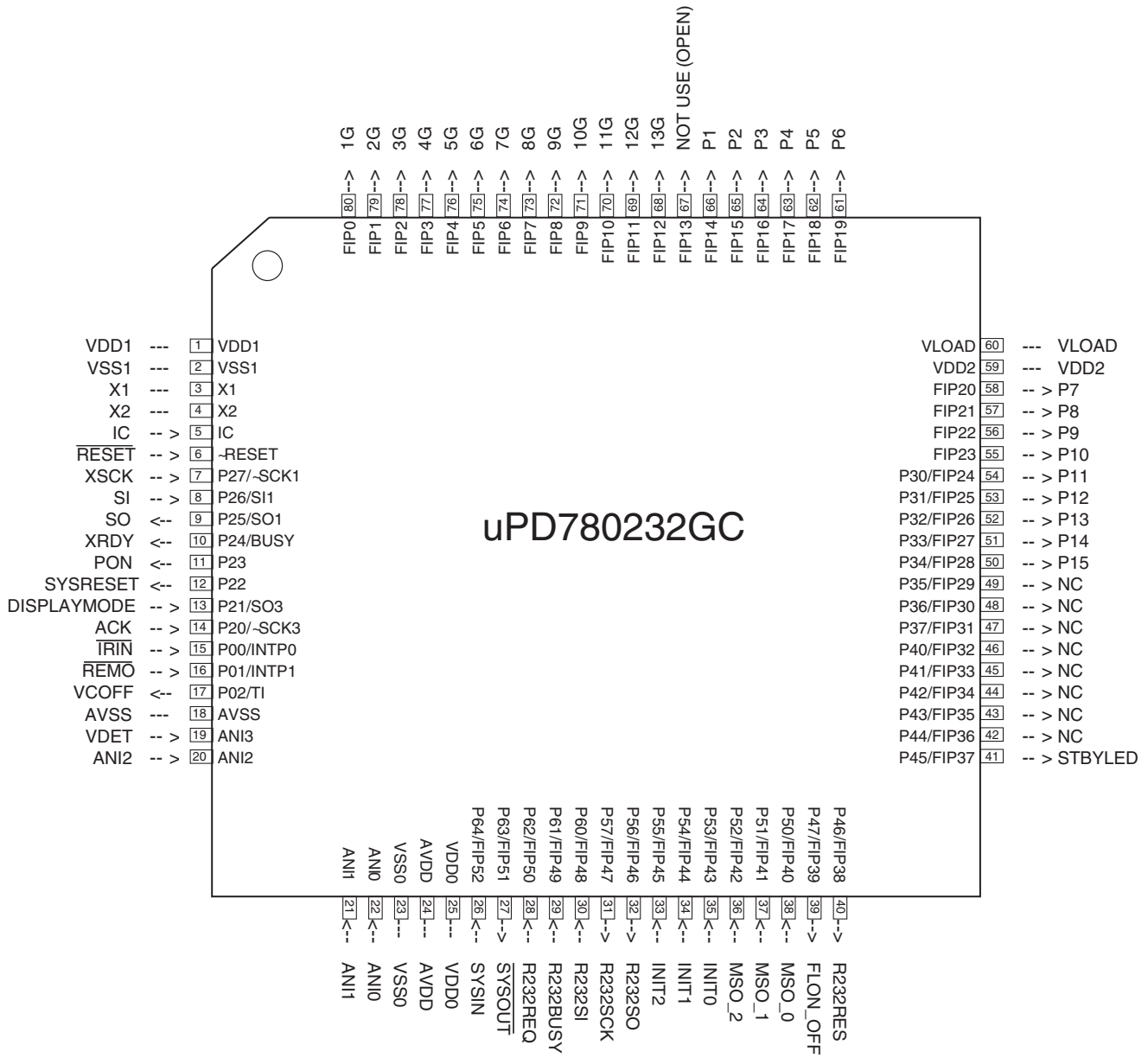

MICROPROCESSOR TERMINAL DESCRIPTION

No.	PIN NAME	SIGNAL	I/O	DESCRIPTION
1	VDD1	VDD1		Power supply port
2	VSS1	VSS1		Ground port
3	X1	X1		Connect to clock oscillator of main micro processor
4	X2	X2		Connect to clock oscillator of main micro processor
5	IC	IC	I	Connect to VSS1
6	~RESET	~RESET	I	System reset input port
7	P27/~SCK1	XSCK	I	Clock output port for writing in FLASH ROM
8	P26/SI1	SI	I	Data input port for writing in FLASH ROM
9	P25/SO1	SO	O	Data output port for writing in FLASH ROM
10	P24/BUSY	XRDY	O	XRDY output port
11	P23	PON	O	POWER ON/OFF control output port to a system processor. "H": Power ON
12	P22	SYSRESET	O	System reset control output port
13	P21/SO3	DISPLAY_MOI	I	Exhibition mode. Active "L":Exhibition mode
14	P20/~SCK3	ACK	I	ACK input port.
15	P00/INTP0	~IRIN	I	IR remote control input port. Active "L": IR mode
16	P01/INTP1	~REMO	I	Remote control signal input port. Active "L": Remote control mode
17	P02/TI	VCOFF	O	Video circuit off control output port.
18	AVSS	AVSS		Ground pin of A/D converter.
19	ANI3	VDET	I	VDET input port
20	ANI2	ANI2	I	Analog input port for A/D converter
21	ANI1	ANI1	I	Analog input port for A/D converter
22	ANI0	ANI0	I	Analog input port for A/D converter
23	VSS0	VSS0		Ground pin
24	AVDD	AVDD		Reference analog power supply of A/D converter. VDD1
25	VDD0	VDD0		Power supply pin
26	P64/FIP52	SYSIN	I	Input port for system buss
27	P63/FIP51	~SYSOUT	O	Output port for system buss
28	P62/FIP50	R232REQ	I	Open pin.
29	P61/FIP49	R232BUSY	I	Open pin.
30	P60/FIP48	R232SI	I	Open pin.
31	P57/FIP47	R232SCK	O	Open pin.
32	P56/FIP46	R232SO	O	Open pin.
33	P55/FIP45	INIT2	I	Initialized setting port of analog input 2
34	P54/FIP44	INIT1	I	Initialized setting port of analog input 1
35	P53/FIP43	INIT0	I	Initialized setting port of analog input 0
36	P52/FIP42	MSO_2	I	Model select input port 2
37	P51/FIP41	MSO_1	I	Model select input port 1
38	P50/FIP40	MSO_0	I	Model select input port 0
39	P47/FIP39	FLON_OFF	O	FL filament control output port
40	P46/FIP38	R232RES	O	Open pin.
41	P45/FIP37	STBYLED	O	STANDBY LED control output port
42	P44/FIP36	NC	O	Open pin.
43	P43/FIP35	NC	O	Open pin.
44	P42/FIP34	NC	O	Open pin.
45	P41/FIP33	NC	O	Open pin.
46	P40/FIP32	NC	O	Open pin.
47	P37/FIP31	NC	O	Open pin.
48	P36/FIP30	NC	O	Open pin.
49	P35/FIP29	NC	O	Open pin.
50	P34/FIP28	P15	O	Segment (P15) control output port for FL tube
51	P33/FIP27	P14	O	Segment (P14) control output port for FL tube
52	P32/FIP26	P13	O	Segment (P13) control output port for FL tube
53	P31/FIP25	P12	O	Segment (P12) control output port for FL tube
54	P30/FIP24	P11	O	Segment (P11) control output port for FL tube
55	FIP23	P10	O	Segment (P10) control output port for FL tube
56	FIP22	P9	O	Segment (P9) control output port for FL tube
57	FIP21	P8	O	Segment (P8) control output port for FL tube
58	FIP20	P7	O	Segment (P7) control output port for FL tube
59	VDD2	VDD2		Power supply port of FIP
60	VLOAD	VLOAD		Connect to a pull down resistor
61	FIP19	P6	O	Segment (P6) control output port for FL tube
62	FIP18	P5	O	Segment (P5) control output port for FL tube
63	FIP17	P4	O	Segment (P4) control output port for FL tube
64	FIP16	P3	O	Segment (P3) control output port for FL tube
65	FIP15	P2	O	Segment (P2) control output port for FL tube
66	FIP14	P1	O	Segment (P1) control output port for FL tube
67	FIP13	NOT USE	O	Open pin.
68	FIP12	13G	O	Grid (13G) control output port for FL tube
69	FIP11	12G	O	Grid (12G) control output port for FL tube
70	FIP10	11G	O	Grid (11G) control output port for FL tube
71	FIP9	10G	O	Grid (10G) control output port for FL tube
72	FIP8	9G	O	Grid (9G) control output port for FL tube
73	FIP7	8G	O	Grid (8G) control output port for FL tube
74	FIP6	7G	O	Grid (7G) control output port for FL tube
75	FIP5	6G	O	Grid (6G) control output port for FL tube
76	FIP4	5G	O	Grid (5G) control output port for FL tube
77	FIP3	4G	O	Grid (4G) control output port for FL tube
78	FIP2	3G	O	Grid (3G) control output port for FL tube
79	FIP1	2G	O	Grid (2G) control output port for FL tube
80	FIP0	1G	O	Grid (1G) control output port for FL tube

DISASSEMBLY DVD MECHANISM-3

Pickup Assy-S

- ① Dislodge the flexible cable for the pickup from its packaged placement.
- ② Remove the flexible cable for the pickup.

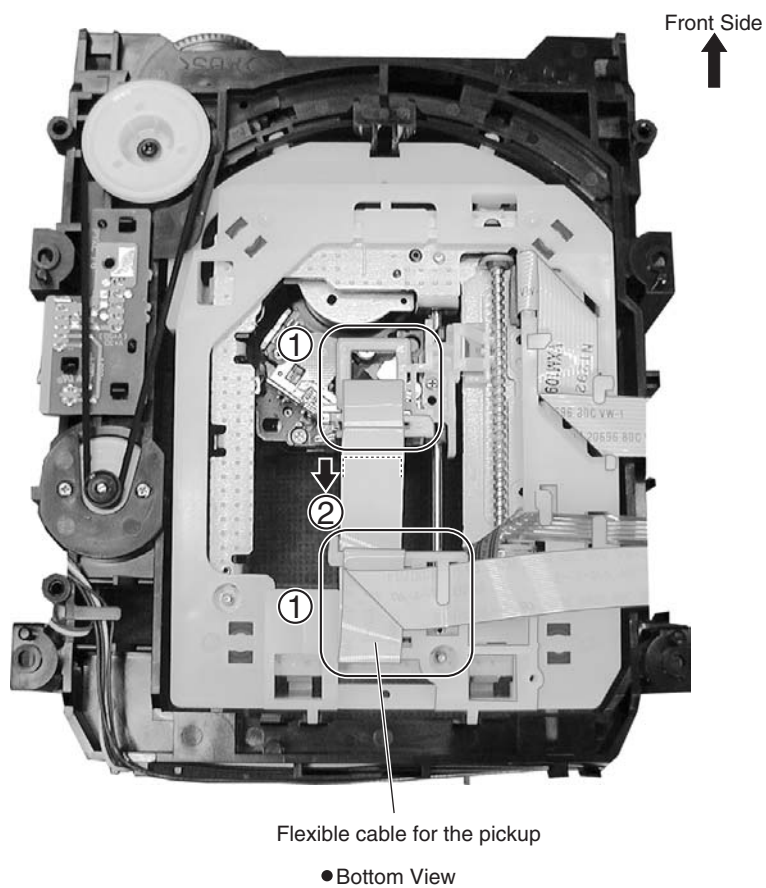

- ③ Remove the two adjustment screws and two adjustment springs.
- ④ Remove the Pickup Assy-S.

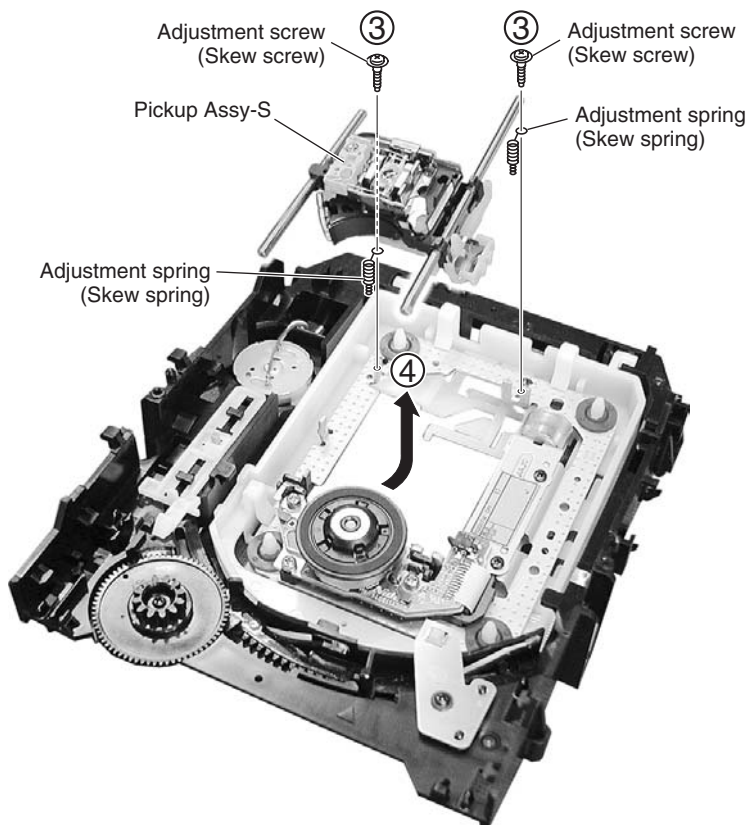

DISASSEMBLY DVD MECHANISM-4

⑤ Remove the two screws.

Note: The screws are secured with epoxy.
Make sure to apply epoxy after reattaching the screws.

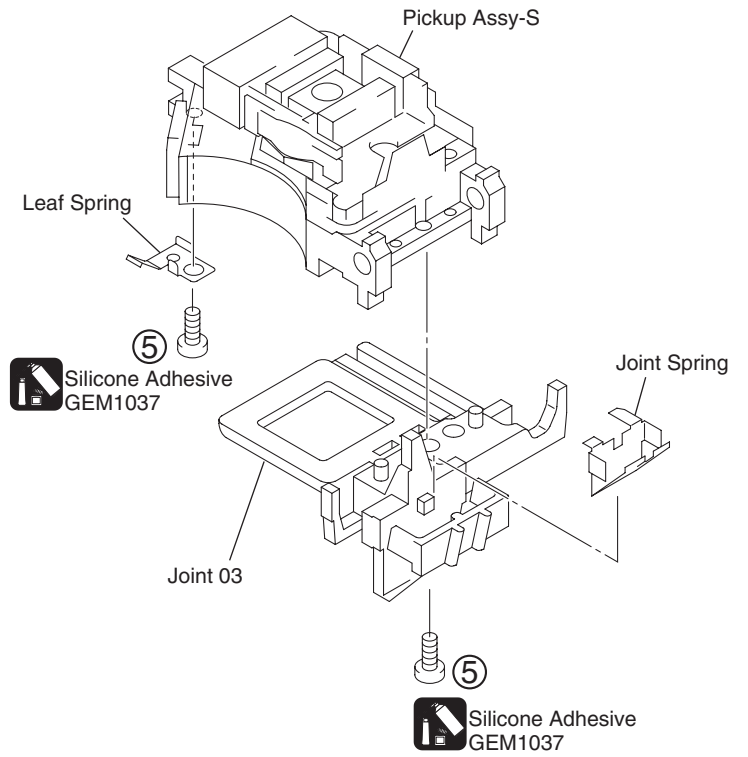

Arrangement of the flexible cable for the spindle motor

■ : Conductive surface

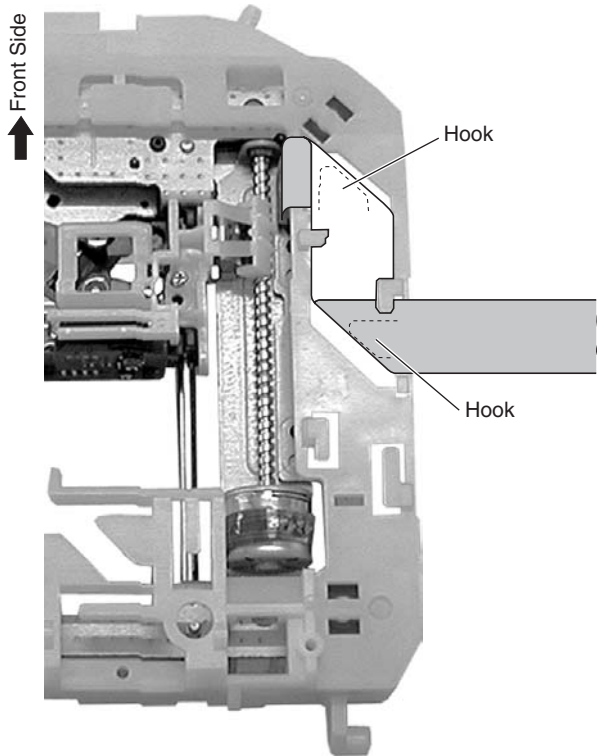

● Bottom View

Arrangement of the flexible cable for the stepping motor

■ : Conductive surface

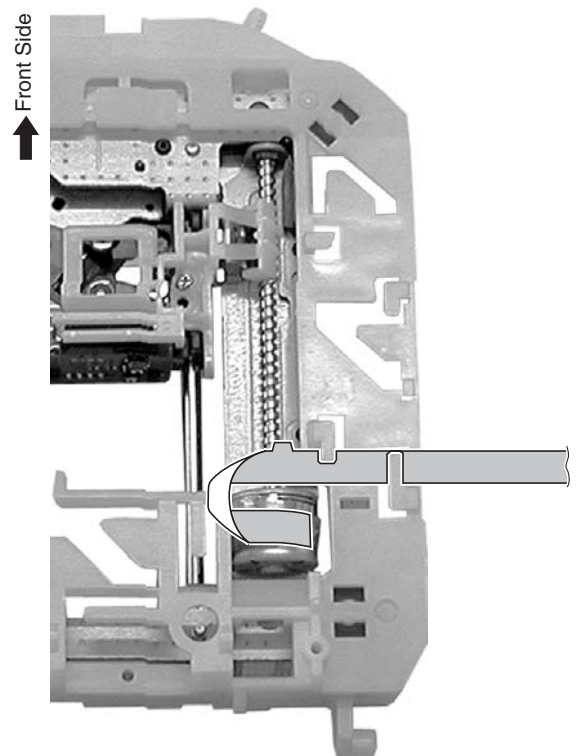

● Bottom View

DISASSEMBLY DVD MECHANISM-5

Arrangement of the flexible cable for the pickup

 : Conductive surface

Note:

Be sure to move the Pickup Assy-S to the innermost perimeter.

- ① Fold the flexible cable inward at the position of the reference line.
- ② Attach the flexible cable of the pickup to the connector.
- ③ Fold the flexible cable of the pickup with the backing inward.

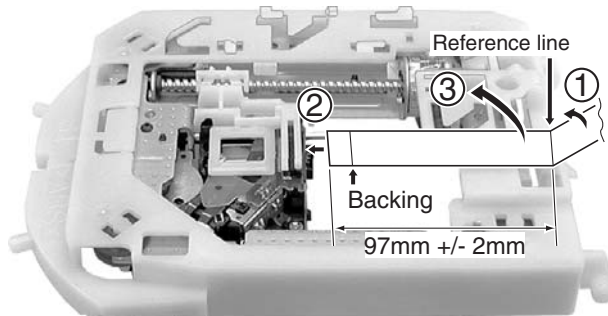

Front Side ← • Bottom View

- ⑦ Pass the flexible cable below the hook, and fold it back.

Make sure that the cable does not have any slack

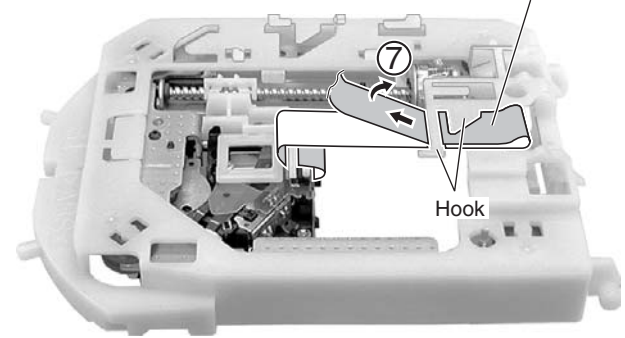

- ④ Pass the flexible cable through the hook not allowing any slack.

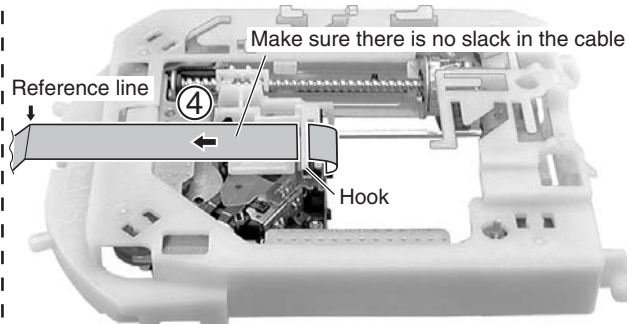

- ⑧ Fold the flexible cable back at the hook.

Make sure that the cable is loose

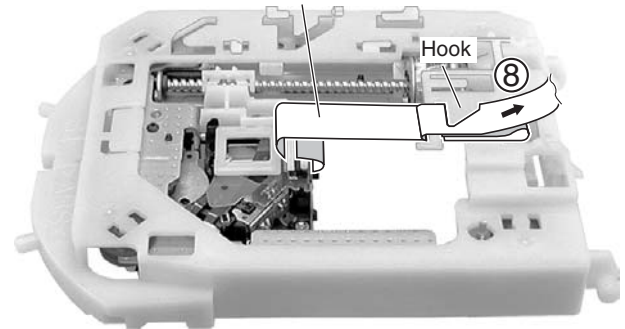

- ⑤ Fold the flexible cable as indicated in the photo.

- ⑥ Hook the part folded in Step 1 to the hook.

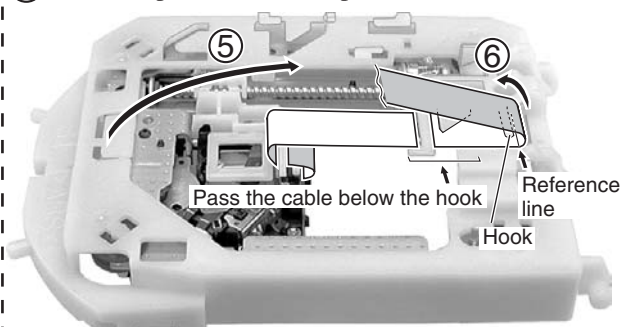

- ⑨ Fold the flexible cable along the hook.

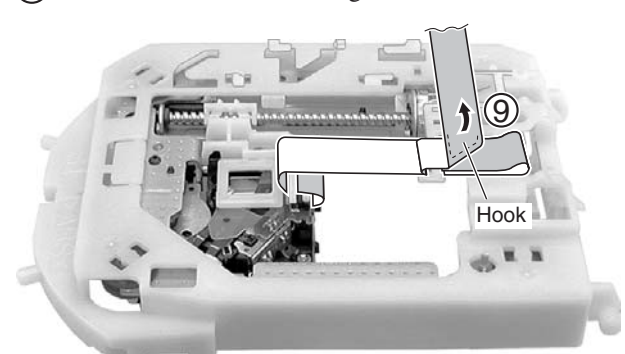

DISASSEMBLY DVD MECHANISM-1

Bonnet

1. Remove the Bonnet by removing the six screws.

How to open the Tray when the power cannot be on

Insert a screwdriver (small) into the slit located at the bottom of the unit, and slide the projection of the Drive Gear in the Loading Mecha. Assy in the direction of the arrow, as

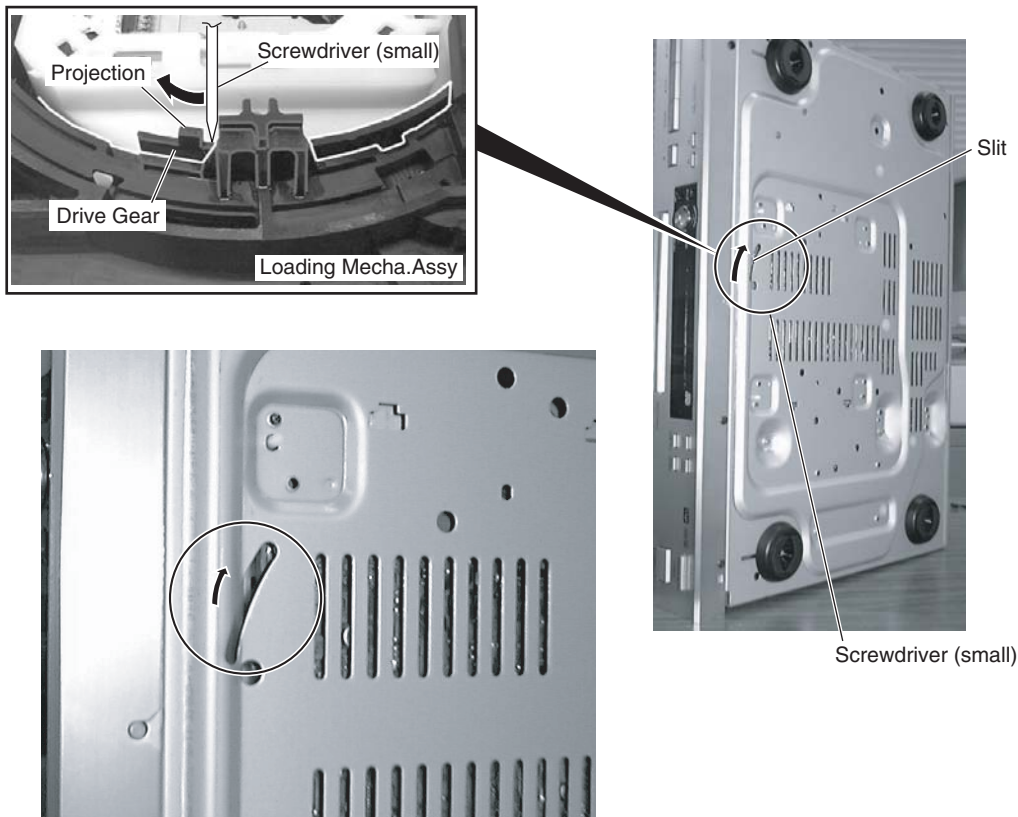

Remove the mechanism assembly

1. Remove three screws (Black 3TT+8B(BC)) from bottom side. Remove the front panel.
2. Remove two screws on front bracket. And release the FFC (P71).
3. Remove two screws on the power switch PC board and wire holder.
4. Remove four screw (3SMS8W.SW+14B(BC)) from DVD mechanism.
5. Soldering the short lands. It is required because of static electricity protection.
6. Remove six FFCs and one connector assy.
7. Remove the DVD mechanism assembly.

DISASSEMBLY DVD MECHANISM-2

Traverse Mecha. Assy-S

- ① Dislodge the flexible cables from their factory placement.

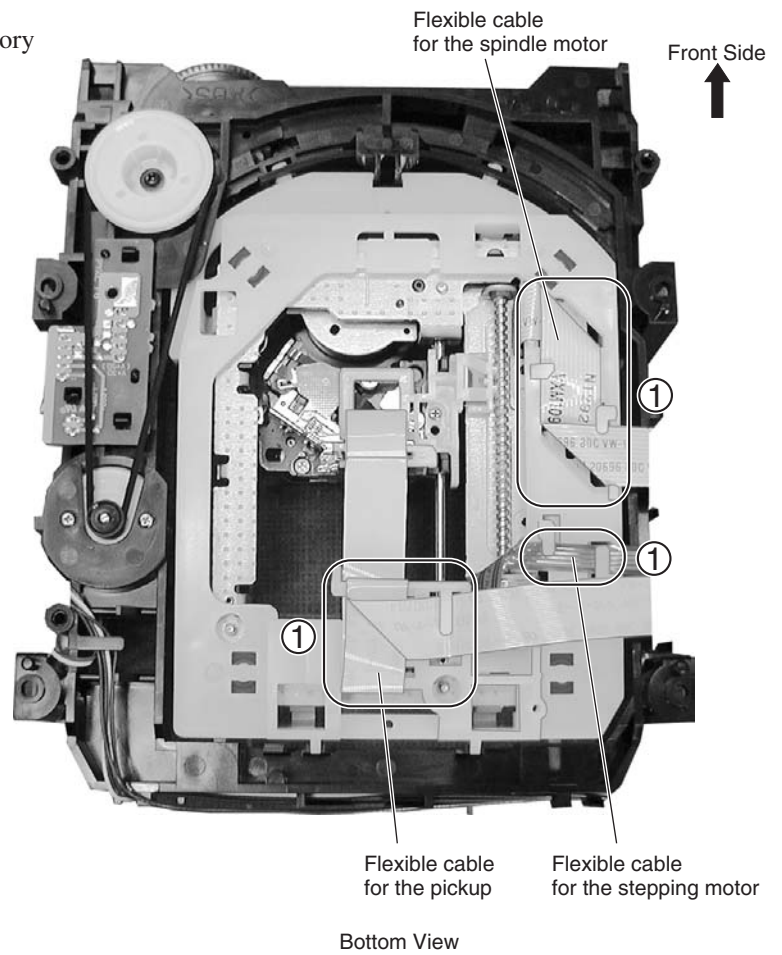

- ② Remove the four hooks.
③ Remove the Traverse Mecha. Assy-S.

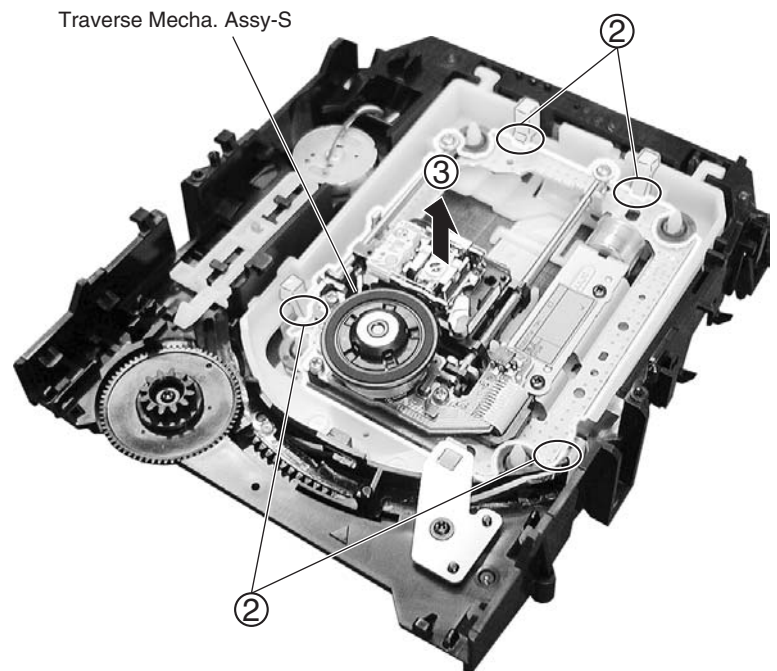

Removing the Traverse Mecha. Assy-S and Pickup Assy-S

1 Loading Mecha. Assy

- ① Remove the bridge by removing the one screw.
- ② Pull out the tray, then remove it by pressing the hook.
- ③ Short-circuit two points of C and D by soldering.

Note: After replacement, connect the flexible cable, then remove the soldered joint (open).

- ④ Remove the four connectors from the Loading Mecha. Assy.
- ⑤ Remove the four screws that secure the Loading Mecha. Assy to the unit.

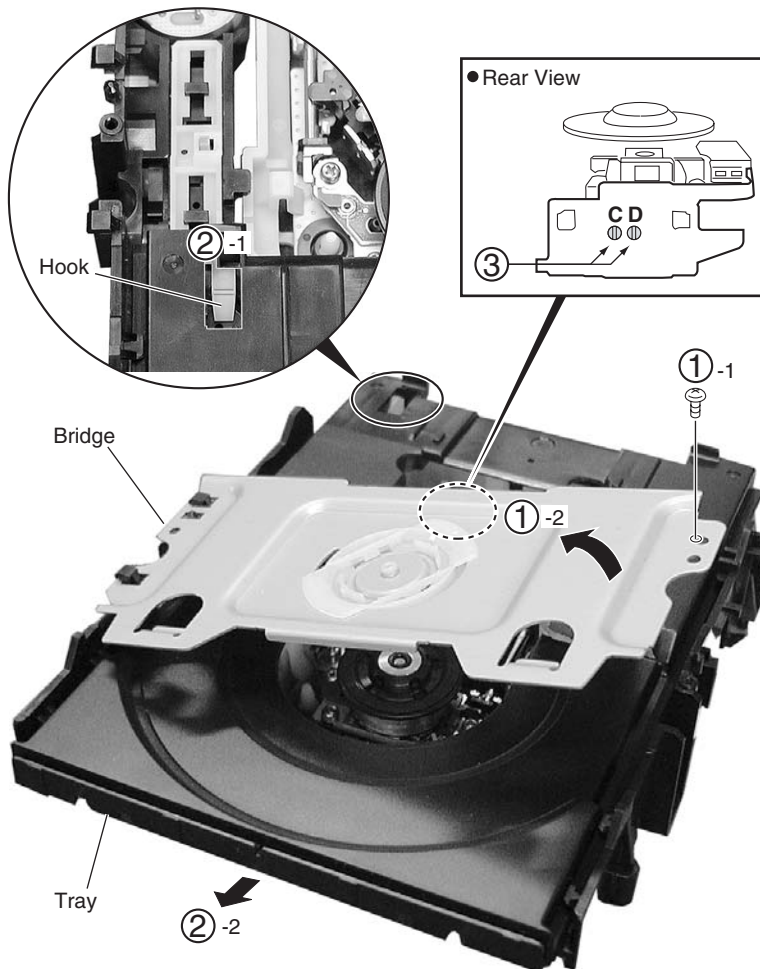

Note : when reinserting the Tray

When reinserting the Tray, first align the triangle printed on the Loading Base and the pin of the Drive Cam, then insert the Tray.

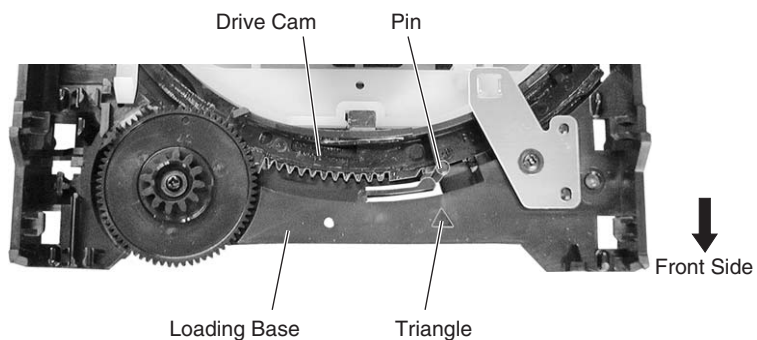

Removing the Traverse Mecha. Assy-S and Pickup Assy-S

2 Traverse Mecha. Assy-S

- ① Dislodge the flexible cables from their factory placement.

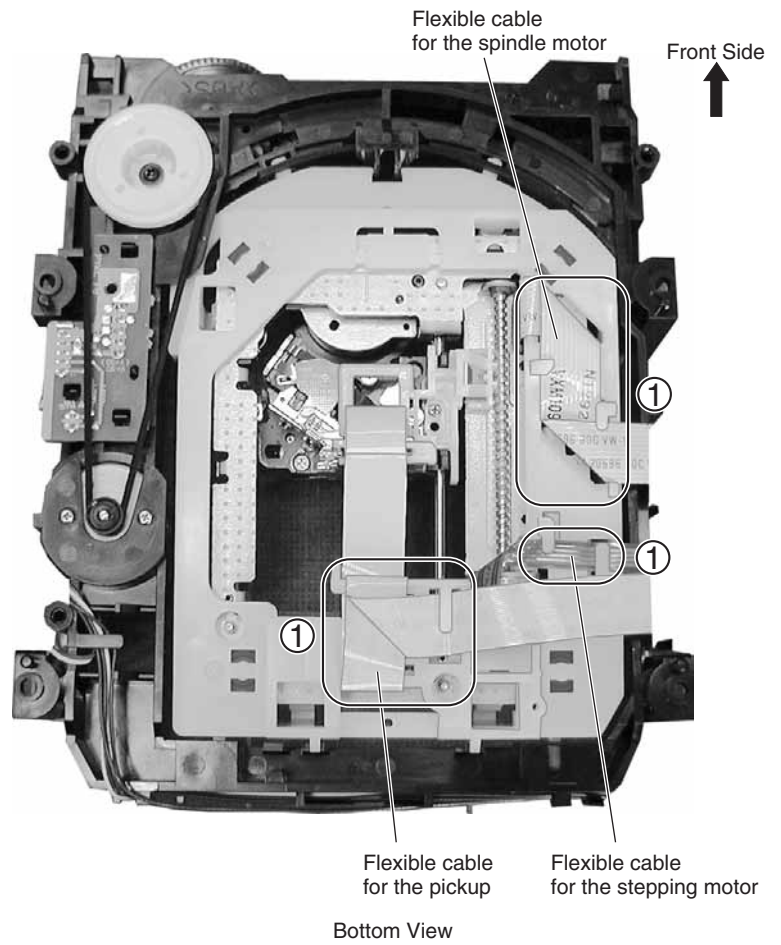

- ② Remove the four hooks.
- ③ Remove the Traverse Mecha. Assy-S.

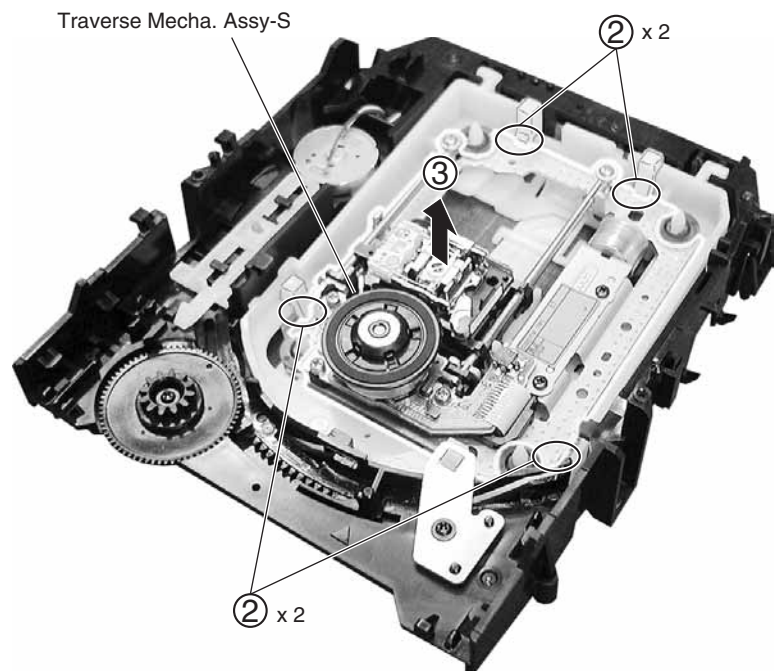

Removing the Traverse Mecha. Assy-S and Pickup Assy-S

3 Pickup Assy-S

Note: The Pickup Assy-S can be removed without removing the Traverse Mecha. Assy-S. (shown as Step.)

- ① Dislodge the flexible cable for the pickup from its packaged placement.
- ② Remove the flexible cable for the pickup.

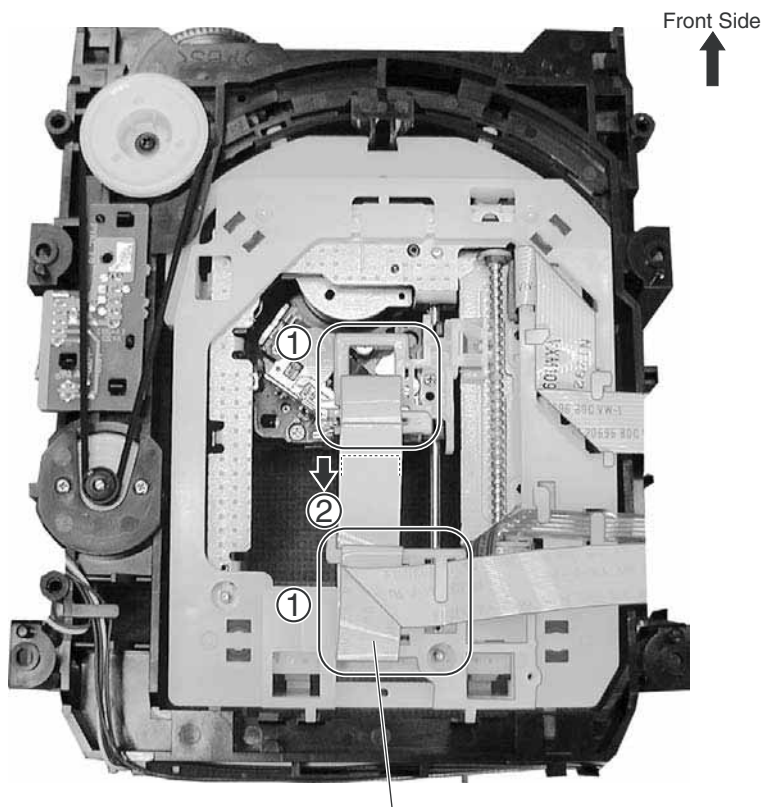

Flexible cable for the pickup

Bottom View

- ③ Remove the two adjustment screws and two adjustment springs.
- ④ Remove the Pickup Assy-S.

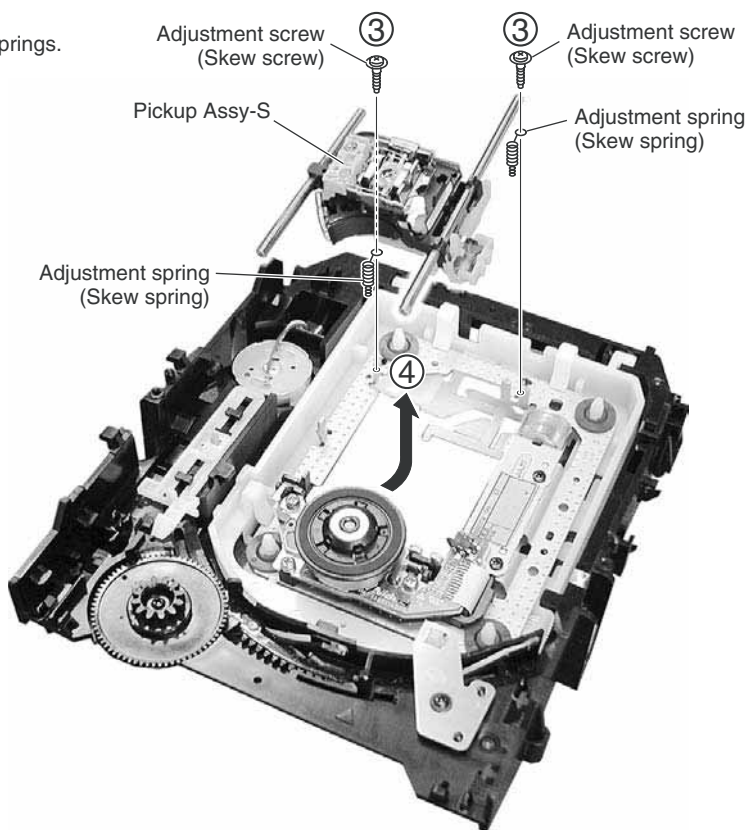

Removing the Traverse Mecha. Assy-S and Pickup Assy-S

⑤ Remove the two screws.

Note: The screws are secured with epoxy. Make sure to apply epoxy after reattaching the screws.

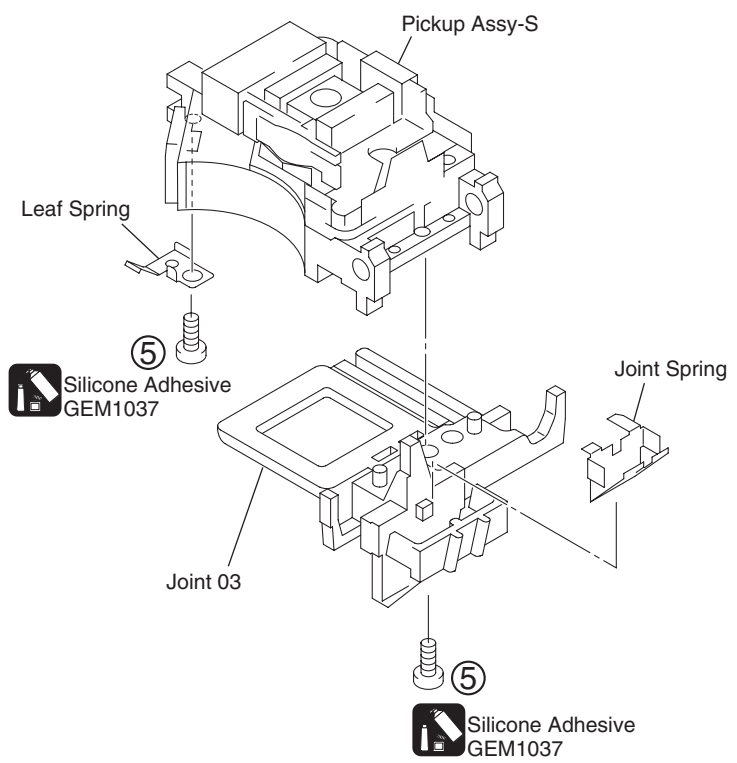

Arrangement of the flexible cable for the spindle motor

■ : Conductive surface

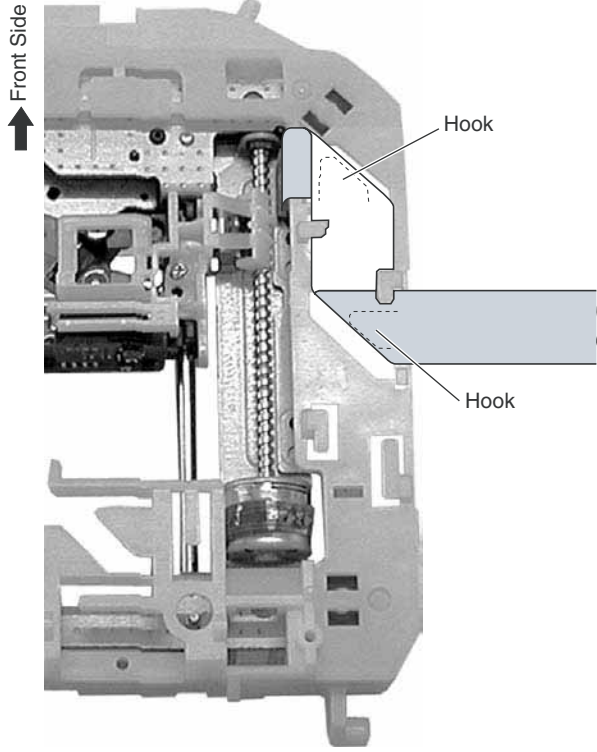

Bottom View

Arrangement of the flexible cable for the stepping motor

■ : Conductive surface

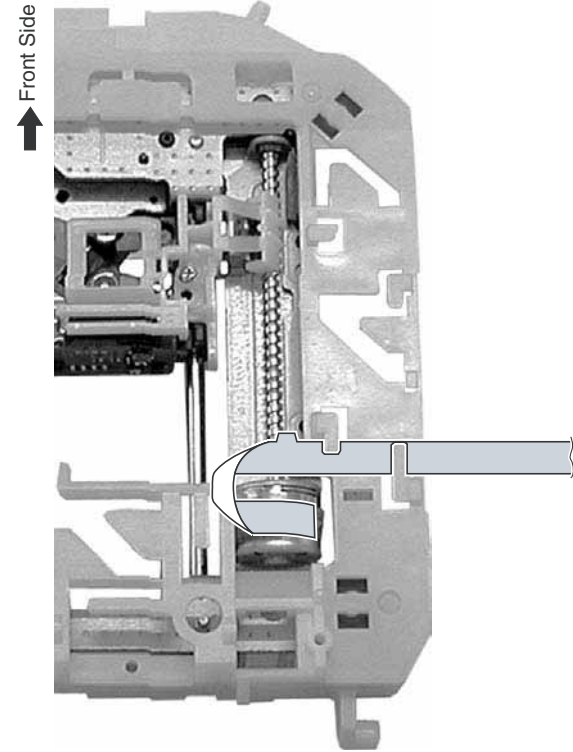

Bottom View

Removing the Traverse Mecha. Assy-S and Pickup Assy-S

Arrangement of the flexible cable for the pickup

 : Conductive surface

Note:

Be sure to move the Pickup Assy-S to the innermost perimeter.

- ① Fold the flexible cable inward at the position of the reference line.
- ② Attach the flexible cable of the pickup to the connector.
- ③ Fold the flexible cable of the pickup with the backing inward.

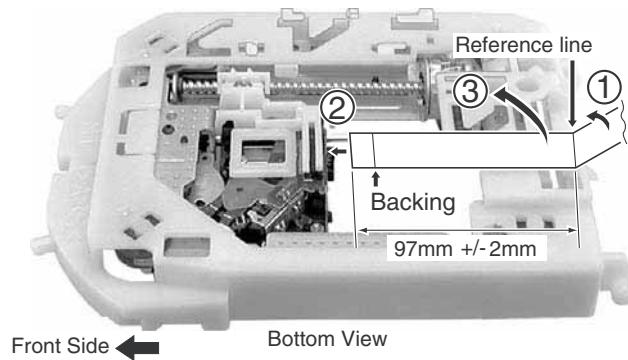

- ⑦ Pass the flexible cable below the hook, and fold it back.
- Make sure that the cable does not have any slack

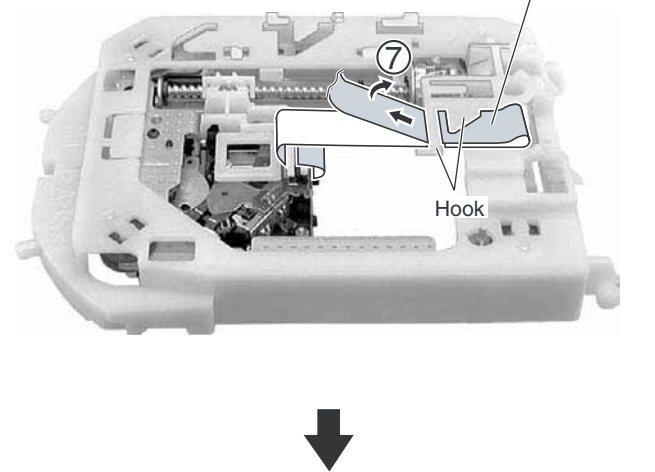

- ④ Pass the flexible cable through the hook not allowing any slack.

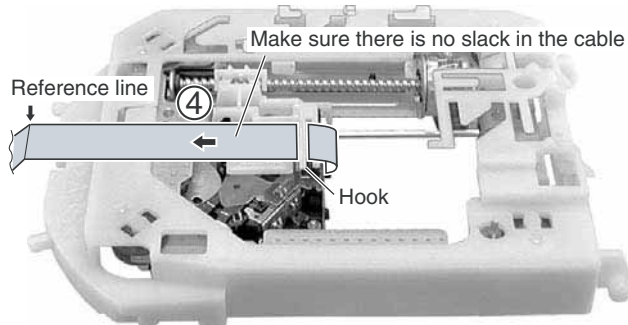

- ⑧ Fold the flexible cable back at the hook.

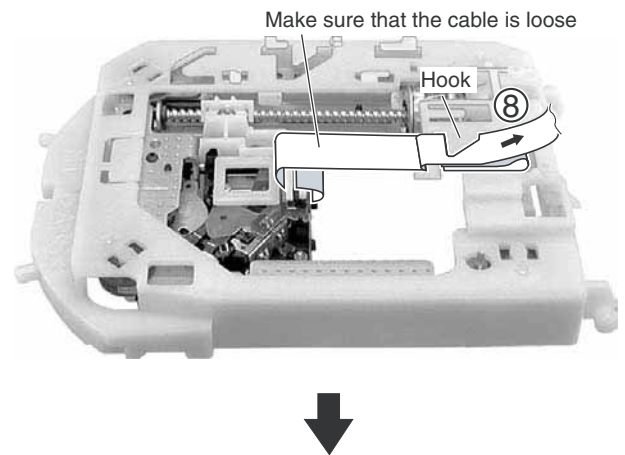

- ⑤ Fold the flexible cable as indicated in the photo.
- ⑥ Hook the part folded in Step ① to the hook.

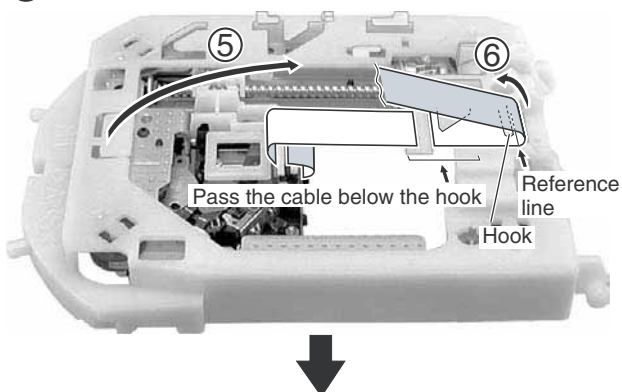

- ⑨ Fold the flexible cable along the hook.

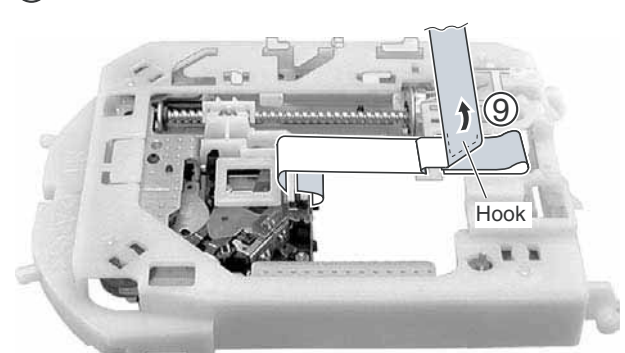

FIRMWARE DOWN LOADING-1

Confirm the Regional code and Firmware version.

1. Connect the TV monitor to the DV-SP501.
2. Turn ON the power switch and standby switch ON. (No Disc)
3. Press the "SETUP" key on the front panel.
Appear a HOME MENU. (Photo-1)
4. Select "Initial Settings" menu and press "ENTER".
5. Select "Options" menu, and press the "DISPLAY" button.
6. Appear regional code and firmware ROM number.
Confirm the regional cord and firmware version.
When close the menu, press "RETURN" button of the unit. (Photo-2)

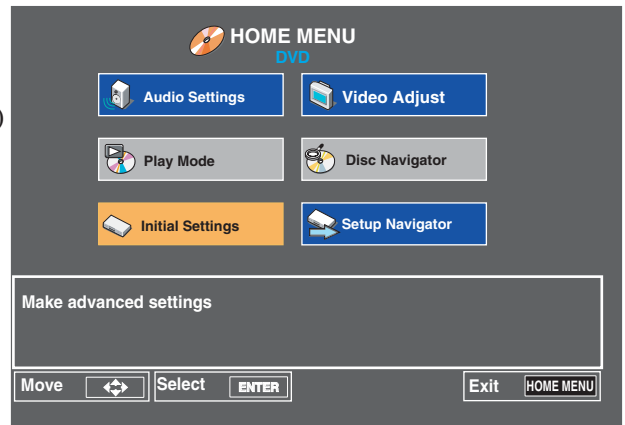

(Photo-1)

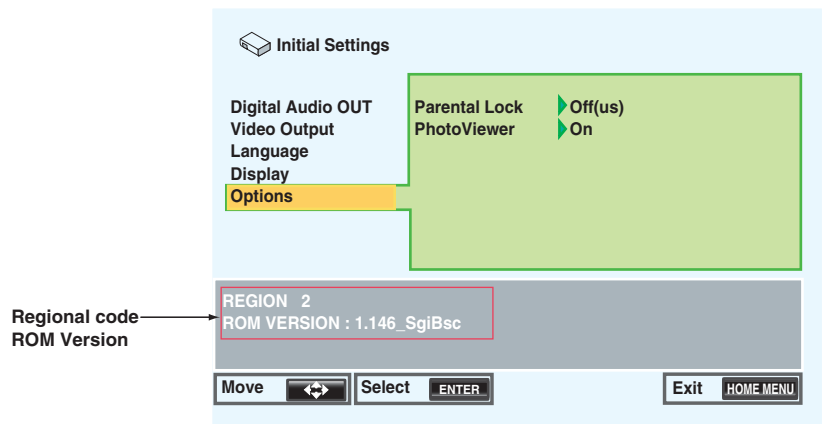

(Photo-2)

UPGRADE FIRMWARE-2

Using for Window tool

1 Writing the firmware as below.

1. Prepare three data on a hard disk of the personal computer.

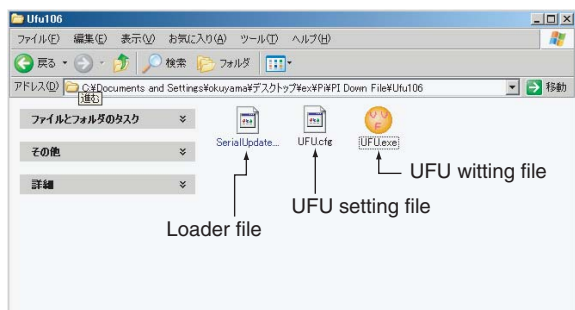

2. Start the UFU.exe file.
Double click the UFU.exe.

3. Select "Easy" mode.
4. Select "File Selection" mode.

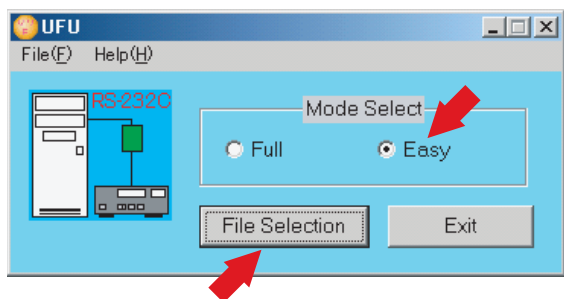

5. Select a program file and open the file.

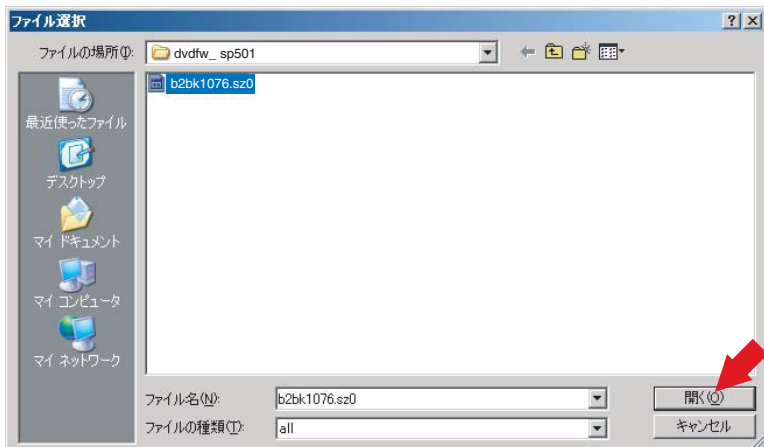

- 6. Connect the JIG (0J13), FFC and connection cable (RS-232C straight type).
- 7. Turn the power switch and standby "ON" of the DV-SP501. No disc condition.
- 8. Press the start key.

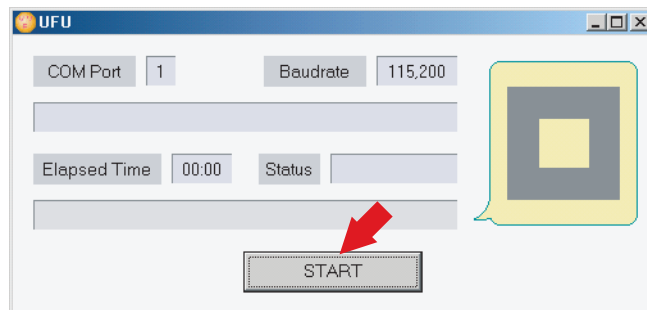

9. Wait for about 10 minutes.

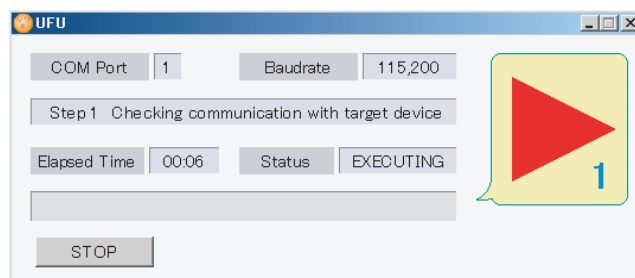

10. Complete the upgrade firmware.



Next step.
Please continue work ID number and ID data set up.

ID NUMBER AND DATA SETTING

Caution: It is necessary to enter individual ID number and ID data to each player when you repair it.

Note: When previous ID number and ID data, such as a factory present ID number and ID data, are maintained, the unit enters ID Number Confirmation Mode when the above keys are pressed. However, if only an ID number is maintained, the unit enters ID Data Input Mode.

- Preparations:**
- ① Remote controller RC-484M
 - ② TV monitor
 - ③ ID Data DVD Disc. (Part No. 0R118)

A: ID number Input Mode

[Remote controller RC-484M]

1. Press "DVD" and "1" at the same time.
2. Press "RETURN" key and "STEREO" key.
3. Enter a 9-digit ID number and ID number is also displayed on the FL display.
4. After entering all 9 digits, when you press the "PLAY" key the unit enters Compare mode.

Note: When you press the PLAY key before inputting a 9- digit ID number, the unit returns to Step 2.

5. After entering all 9 digits, when you press the "SEARCH" key, the unit unconditionally sets the input number as the ID number. Then the unit automatically enters Player's Data input Mode.
6. This display appears when the "PLAY" key is pressed in step 4. Enter a 9- digit number to compare.
7. After entering all 9 digits, you press the "PLAY" key.

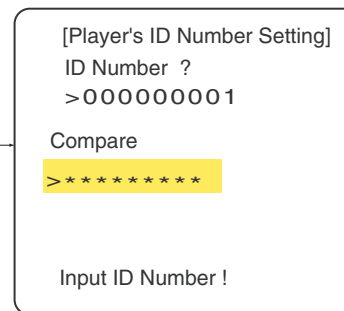
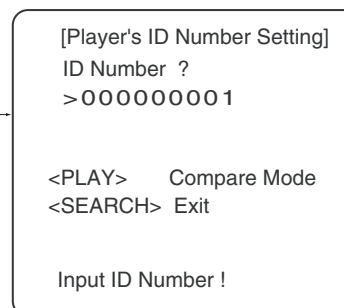
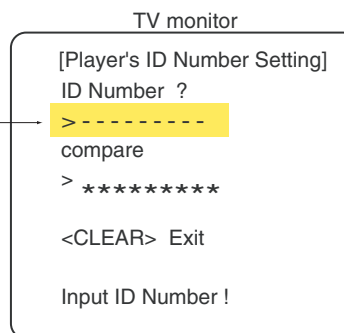
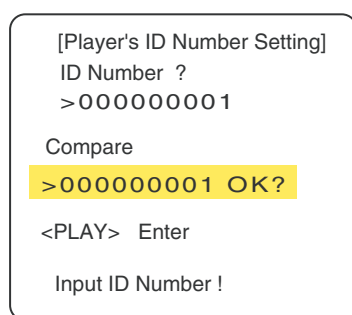

ID NUMBER AND DATA SETTING

B : ID DATA Input Mode

[Remote controller RC-484M]

1. Press "DVD" and "1" at the same time.
2. Press "RETURN" key and "STEREO" key.
3. Enter a 9-digit ID data.

4. After entering all 9 digits, when you press the "PLAY" key, the unit enters Compare mode.
5. Entering 9- digits again, and press the "PLAY" key.
6. Insert the data disc on the tray of the unit.
7. Writing the data, automatically.
About 2 minutes.

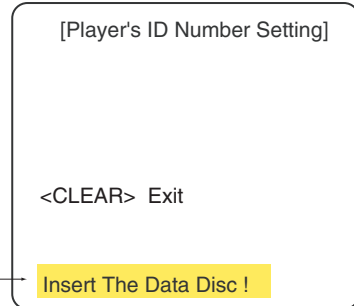
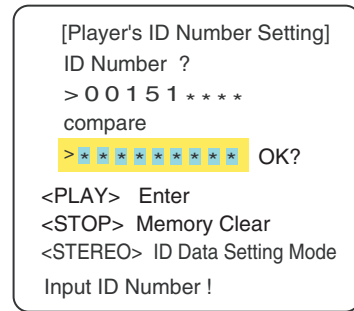
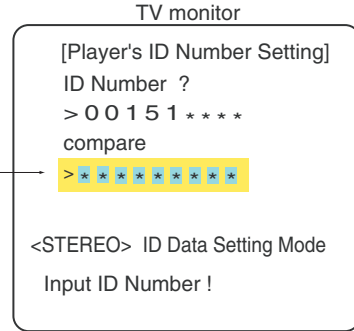
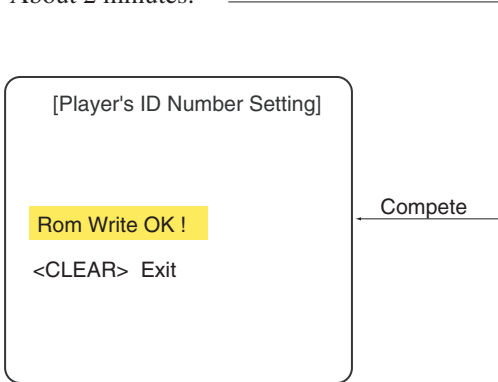

8. Press open the tray of the unit, and take out a disc.
9. Push the power switch off (Mechanical switch) .
Push the power switch, standby switch on and close the tray.

PACKIN VIEW
EXCEPT <MUP> MODEL

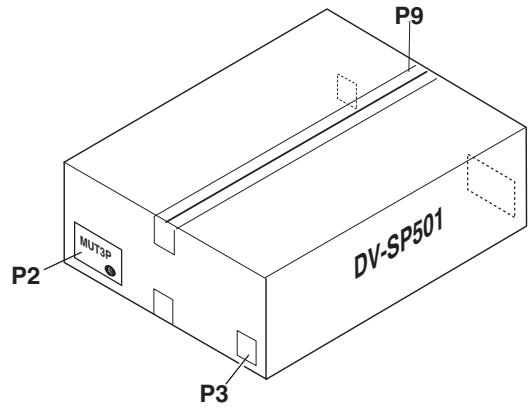
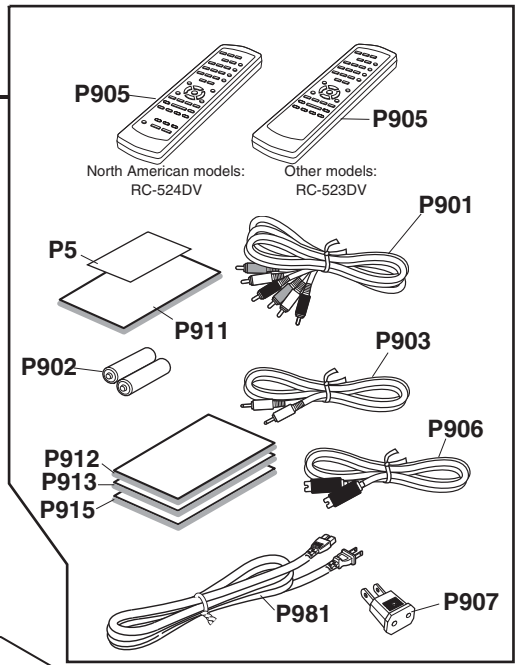
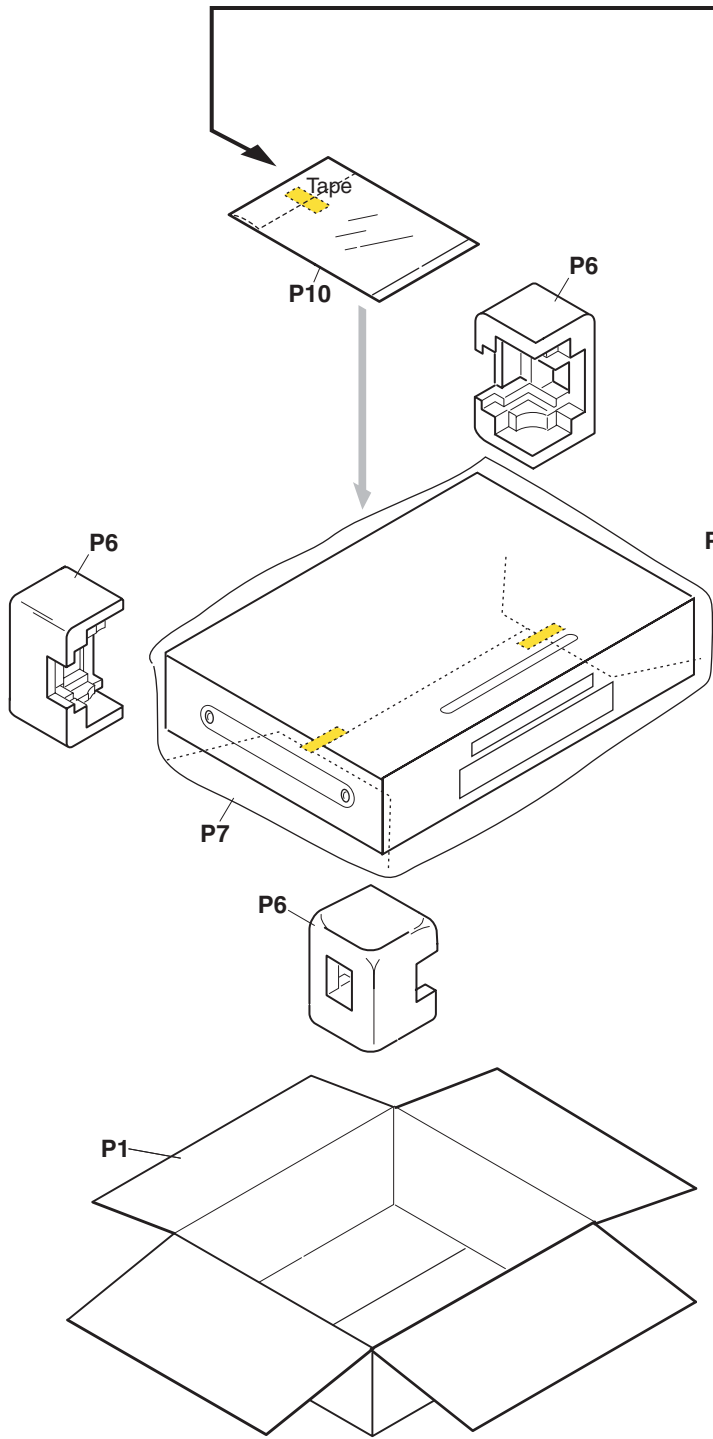

PACKING VIEW

<MUP> model only

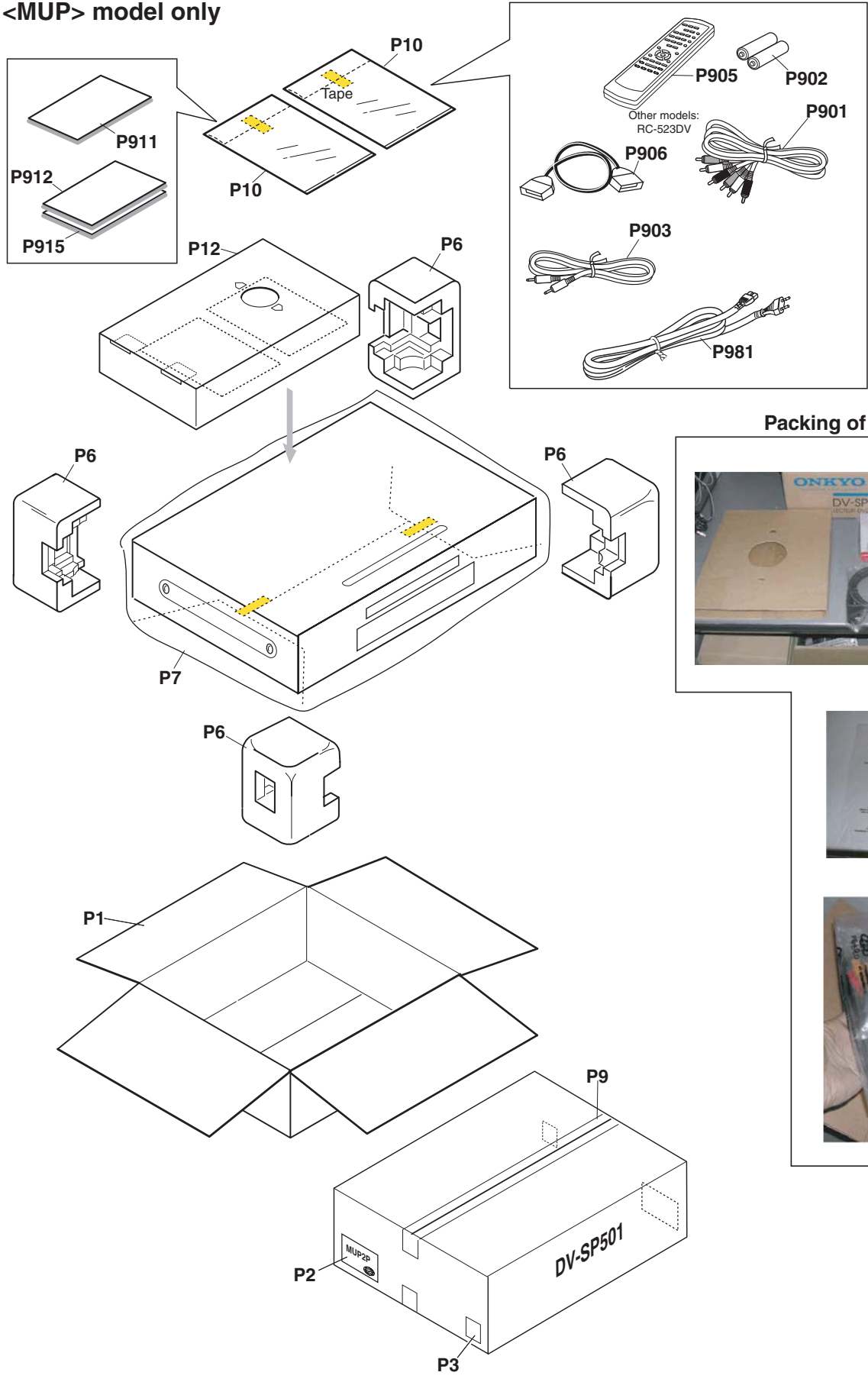

Packing of accessory

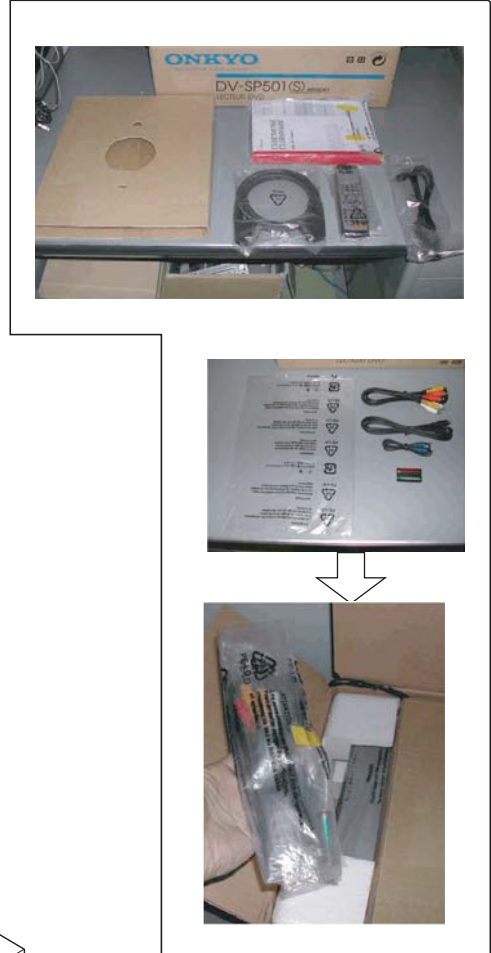

EXPLODED VIEW PARTS LIST

! : Safety part

REF. NO.	PART NAME	DESCRIPTION	PART NO.	REMARK
A1	CHASSIS		27100425B	
A3	LEG	LEG	27175316C	
A5	CUSHION		28141494	
A10	HOLDER	KGLS-10RT	27190428A	
A11	SCREW	3TTB+8B	838130088	
A11a	WASHER	W3*10F(BC)	87643010	
A12	HOLDER	KGLS-18RT	27190657	
A13	HOLDER	KGLS-22RT	27190772	
A15	LABEL(DVD2)		29362648	
A16	CLAMP	HL-18-0	27301394	
A19	F BRACKET	AS, Included konb-cap 	27111328A	N
A19	F BRACKET	AS, Included konb-cap <G>	27111330A	N
A19	F BRACKET	AS, Included konb-cap <S>	27111329A	N
A22	CLEAR PLT		28191991	N
A22	CLEAR PLT	<G>, <S>	28191992	N
A23	TAPE		29110161	
A27	SCREW	2.6TTB+8B(BC)	838426088	
A30	KNOB	(POWER), 	28325497A	
A30	KNOB	(POWER), <G>	28325499A	
A30	KNOB	(POWER), <S>	28325547A	
A32	SCREW	3P+10FN(BC)	82143010	
A35	KNOB	(CRS) 	28326029	
A35	KNOB	(CRS) <G> <S>	28326030	
A51	DOOR		28148540	N
A51	DOOR	<G>	28148542	N
A51	DOOR	<S>	28148541	N
A55	COVER		28184864	N
A55	COVER	<G>	28184866	N
A55	COVER	<S>	28184865	N
A56	SCREW	3TTB+8B(BC) 	838430088	
A56	SCREW	3TTB+8B(UN) <G> <S>	838930088	
A57	CUSHION	HIME 0.5*120*10	28141542	N
A41	F PANEL	<Except B MUP>	27212522	N
A41	F PANEL	<B MUP>	27212524	N
A41	F PANEL	<G MUT>	27212526	N
A41	F PANEL	<G MUK> <G MUR>	27212526	N
A41	F PANEL	<S MUP>	27212525	N
A41	F PANEL	<S MUS>	27212523	N
A43	BADGE		28135244	
A43	BADGE	<G> <S>	28135245	
A44	FACET		28198906	
A46	SCREW	3TTB+8B(BC)	838430088	
A47	REAR PANEL	<B MDD,B MDC>	27123120A	N
A47	REAR PANEL	<B MUT>	27123123A	N
A47	REAR PANEL	<B MUS> <S MUS>	27123122A	N
A47	REAR PANEL	<B MUP> <S MUP>	27123118A	N
A47	REAR PANEL	<G MUT> <G MUK>	27123123A	
A47	REAR PANEL	<G MUR>	27123121A	N
A48	SCREW	3TTB+8B(BC) Except <B MUP> <SMUP>	838430088	
A48	SCREW	3TTB+8B(BC) <B MUP>	838430088	
F1	FUSE	! 1.6A-T/UL-ST2 <MDD> <MDC>	252252	
F1 or	FUSE	! 1.6A-TSC	252147	
F1	FUSE	! 1.6A-SE-TL250V Except <MDD> <MDC>	252273	
F1 or	FUSE	! 1.6A-SE-EAK IEC	252073	
P501	FFC	NCFC5-301512	2045301512	
P502	FFC	NCFC5-110612	2045110612	N
P503	FFC	NCFC5-180712	2045180712	N
P701	FFC	NCFC5-182012	2045182012	
P702	SOCKET AS	NSAS-10P1160	20044391025	
P901A	CORE	NFY-25 BLACK	230945	
P910	WIRE TIE	BINDER(CLAMPER)UL	260208	
S731	JOY STICK	NPS-115-S673	25035710	
Z1	DVD Main circuit PC board assy	DB-VPB501	24150042	N
Z10	DVD Mechanism assy	DB-VLD501-007	24801018	N

Z12	HOLDER	(ML)	27191201	N
Z13	HOLDER	(MR)	27191202	N
Z14	SCREW	3SMS8W.SW+14B(BC)	801433	
Z91A	SCREW	4TTC+8C(BC)	830440089	
U1	Output terminal PC board assy	NAAR-7997-1A <MDD> <MDC>	1H505597-1A	N
U1	Output terminal PC board assy	NAAR-7997-1B <MUP>	1H505597-1B	N
U1	Output terminal PC board assy	NAAR-7997-1C <MUT> <MUK>	1H505597-1C	N
U1	Output terminal PC board assy	NAAR-7997-1D <MUS>	1H505597-1D	N
U1	Output terminal PC board assy	NAAR-7997-1E <MUR>	1H505597-1E	N
U2	Display circuit PC board assy	NADIS-7998-1A <MDD> <MDC>	1H505598-1A	N
U2	Display circuit PC board assy	NADIS-7998-1B <MUP>	1H505598-1B	N
U2	Display circuit PC board assy	NADIS-7998-1C <MUT> <MUK>	1H505598-1C	N
U2	Display circuit PC board assy	NADIS-7998-1D <MUS>	1H505598-1D	N
U2	Display circuit PC board assy	NADIS-7998-1E <MUR>	1H505598-1E	N
U3	Standby switch PC board assy	NADIS-7999-1A <MDD> <MDC>	1H505599-1A	N
U3	Standby switch PC board assy	NADIS-7999-1B <MUP>	1H505599-1B	N
U3	Standby switch PC board assy	NADIS-7999-1C <MUT> <MUK>	1H505599-1C	N
U3	Standby switch PC board assy	NADIS-7999-1D <MUS>	1H505599-1D	N
U3	Standby switch PC board assy	NADIS-7999-1E <MUR>	1H505599-1E	N
U4	Power switch PC board assy	NASW-8000-1A <MDD> <MDC>	1H505500-1A	N
U4	Power switch PC board assy	NASW-8000-1B <MUP>	1H505500-1B	N
U4	Power switch PC board assy	NASW-8000-1C <MUT> <MUK>	1H505500-1C	N
U4	Power switch PC board assy	NASW-8000-1D <MUS>	1H505500-1D	N
U4	Power switch PC board assy	NASW-8000-1E <MUR>	1H505500-1E	N
U5	Inlet terminal PC board assy	NAPS-8001-1A <MDD> <MDC>	1H505501-1A	N
U5	Inlet terminal PC board assy	NAPS-8001-1B <MUP>	1H505501-1B	N
U5	Inlet terminal PC board assy	NAPS-8001-1D <MUS>	1H505501-1D	N
U5	Inlet terminal PC board assy	NAPS-8001-1C <MUT> <MUK>	1H505501-1C	N
U5	Inlet terminal PC board assy	NAPS-8001-1E <MUR>	1H505501-1E	N
U6	Support PC board	NAETC-8003-1A <MDD> <MDC>	1H505503-1A	N
U6	Support PC board	NAETC-8003-1B <MUP>	1H505503-1B	N
U6	Support PC board	NAETC-8003-1C <MUT> <MUK>	1H505503-1C	N
U6	Support PC board	NAETC-8003-1D <MUS>	1H505503-1D	N
U6	Support PC board	NAETC-8003-1E <MUR>	1H505503-1E	N
U20	Power supply assy unit	! NGPS-0040-100-120V <MDD> <MDC>	24150040	N
U20	Power supply assy unit	! NGPS-0041-100-240V Except <MDD> <MDC>	24150041	N

: Black color model
 <S>: Silver color model
 <G>: Golden color model
 <MDD>: North American area
 <MDC>: Canadian area
 <MUT>: Southeast Asia area
 <MUK>: Korea area
 <MUS>: South America area
 <MUP>: European area
 <MUR>: China area

PACKING VIEW PARTS LIST

! : Safety part

REF. NO.	PART NAME	DESCRIPTION	PART NO.	REMARK
P1	CARTON	<B MDD,B MDC,B MUT,B MUS>	29054056	N
P1	CARTON	<B MUP>	29054057	N
P1	CARTON	<G MUT> <G MUR> <G MUK>	29054060	N
P1	CARTON	<S MUP>	29054058	N
P1	CARTON	<S MUS>	29054059	N
P2	LABEL	(RE) <B MDC>	29363451	N
P2	LABEL	(RE) <B MUT>	29363448	N
P2	LABEL	(RE) <B MUS>	29363449	N
P2	LABEL	(RE) <MUK>	29363450	N
P3	UPC LABEL	<B MDD,B MDC>	29363445	N
P3	EAN LABEL	<B MUP> <B MUS> <B MUT>	29363442	N
P3	EAN LABEL	<G MUT> <G MUK> G MUR>	29363444	N
P3	EAN LABEL	<MUP> <S MUS>	29363443	N
P4	LABEL	(POP) <B MDD,B MDC>	29363447	N
P5	WRNTY CARD	<B MDD,B MDC>	29365090A	
P6	PAD	(AS)	29092099B	N
P7	POLY BAG	650 x 500	29100037-1A	
P9	PP TAPE	W48 OPP TAPE	29110148	
P10	POLY BAG	350*250 <B MUP> <SMUP>	29100097-1A	
P12	PAD	TOP <B MUP> <S MUP>	29092108A	N
P901	PIN CORD AS	RCA3P(YWR)	2010379	
P902	BATTERY	R6/AA(UM-3)	3010054	
P903	PLUG CORD	3.5-MINI PLUG (RI)	2010200	
P905	REMO CON	RC-524DV <MDD> <MDC>	24140524	N
P905	REMO CON	RC-523DV Except <MDD> <MDC>	24140523	N
P906	CORD AS	(S CORD) Except <MUP>	2010380	
P906 or	CORD AS	TPX3000	2010360	
P906	RGB CORD	YAF11-1015 <MUP>	2010411	
P906 or	RGB CORD	YAF11-0697	2010368	
P907	CV PLUG	! CV-K-2 <MUS> <MUT>	25055911	
P911	INS MANUAL	En	29343485	N
P912	INS MANUAL	U2FrEs <MDC> <MUS> <MUP>	29343487	N
P913	INS MANUAL	U2CtCs <MUT> <MUR>	29343488	N
P915	INS MANUAL	U4ItDeNISv <MUP>	29343490A	N
P981	AC CORD	! AC-UC-2 <MDD> <MDC>	253296HIT	
P981	AC CORD	! AS-CEE <MUP> <MUS> <MUT>	253299HIT	
P981	AC CORD	! AS-KS <MUK> <MUR>	253346VOL	
P981 or	AC CORD	! AS-CCC <MUK> <MUR>	253363HIT	

: Black color model
 <S>: Silver color model
 <G>: Golden color model
 <MDD>: North American area
 <MDC>: Canadian area
 <MUT>: Southeast Asia area
 <MUK>: Korea area
 <MUS>: South America area
 <MUP>: European area
 <MUR>: China area

PRINTED CIRCUIT BOARD PARTS LIST

U1 : OUTPUT TERMINAL PC BOARD NAAR-7997

CIRCUIT PART NAME		DESCRIPTION	PART NO.	REMARK
C101	C-CERA C	CK725F1E-104Z1	332161040R1	
C221	VR C	CE04W6.3V-470M(VR)	394624717	
C222	C-CERA C	CK725B1C-104K1	332121045R1	
C223	VR C	CE04W6.3V-470M(VR)	394624717	
C224	VR C	CE04W6.3V-1000M(VR)	394621027	Except <MUP>
C225	VR C	CE04W6.3V-470M(VR)	394624717	Except <MUP>
C226	VR C	CE04W6.3V-470M(VR)	394624717	Except <MUP>
C352	C-CERA C	CK725F1E-104Z1	332161040R1	
C353	VR C	CE04W6.3V-100M(VR)	394621017	
C357	C-CERA C	CK725B1C-104K1	332121045R1	
C358	C-CERA C	CC725CH1H-220J1	342102204R1	
C360	C-CERA C	CK725F1E-104Z1	332161040R1	
C361	C-CERA C	CK725F1E-104Z1	332161040R1	
C362	VR C	CE04W6.3V-100M(VR)	394621017	
C363	C-CERA C	CK725F1H-223Z1	332152230R1	
C364	C-CERA C	CK725F1H-223Z1	332152230R1	
C401	VX C	CE04W16V-47M(VX)	393344707	
C402	VX C	CE04W16V-47M(VX)	393344707	
C403	TF C	ECQ-B50V-681J	374726814	
C404	TF C	ECQ-B50V-681J	374726814	
C405	TF C	ECQ-B50V-152J	374721524	
C406	TF C	ECQ-B50V-152J	374721524	
C407	TF C	ECQ-B50V-102J	374721024	
C408	TF C	ECQ-B50V-102J	374721024	
C409	C-CERA C	CC725CH1H-470J1	342104704R1	
C410	C-CERA C	CC725CH1H-470J1	342104704R1	
C411	VR C	CE04W6.3V-220M(VR)	394622217	
C412	VR C	CE04W6.3V-220M(VR)	394622217	
C413	VX C	CE04W50V-47M(VX)	393384707	
C414	VX C	CE04W50V-47M(VX)	393384707	
C415	VX C	CE04W50V-47M(VX)	393384707	
C419	VX C	CE04W50V-47M(VX)	393384707	
C420	VR C	CE04W6.3V-470M(VR)	394624717	
C485	VR C	CE04W16V-220M(VR)	394642217	
C486	VR C	CE04W16V-220M(VR)	394642217	
C601	VR C	CE04W16V-100M(VR)	394641017	<MUP>
C602	C-CERA C	CK725F1E-104Z1	332161040R1	<MUP>
C603	VR C	CE04W16V-100M(VR)	394641017	<MUP>
C612	VR C	CE04W6.3V-470M(VR)	394624717	<MUP>
C613	VR C	CE04W6.3V-470M(VR)	394624717	<MUP>
C614	VR C	CE04W6.3V-470M(VR)	394624717	<MUP>
C615	VR C	CE04W6.3V-470M(VR)	394624717	<MUP>
C901	C-CERA C	CK725F1E-104Z1	332161040R1	
C902	VR C	CE04W16V-220M(VR)	394642217	
C903	C-CERA C	CK725F1E-104Z1	332161040R1	
C904	VR C	CE04W6.3V-220M(VR)	394622217	
C905	C-CERA C	CK725F1E-104Z1	332161040R1	
C906	VR C	CE04W16V-220M(VR)	394642217	
C907	C-CERA C	CK725F1E-104Z1	332161040R1	
C908	VR C	CE04W16V-1000M(VR)	394641027	
C909	C-CERA C	CK725F1E-104Z1	332161040R1	
C910	VR C	CE04W16V-1000M(VR)	394641027	
C911	VR C	CE04W16V-100M(VR)	394641017	
C914	C-CERA C	CK725F1E-104Z1	332161040R1	
C920	VR C	CE04W16V-10M(VR)	394641007	
C921	VR C	CE04W16V-220M(VR)	394642217	
C922	VR C	CE04W16V-220M(VR)	394642217	
CN901	SOCKET	NSCT-30P2421	25052524	N

CN901 or SOCKET	NSCT-30P1741	25051954	
CN901 or SOCKET	NSCT-30P2227	25052330	
CN902 SOCKET	NSCT-11P2402	25052505	N
CN902 or SOCKET	NSCT-11P1822	25051935	
CN902 or SOCKET	NSCT-11P2208	25052311	N
CN903 SOCKET	NSCT-18P2409	25052512	
CN903 or SOCKET	NSCT-18P1729	25051942	
CN903 or SOCKET	NSCT-18P2215	25052318	
D101 ZENER D	UDZS5.1B	224550510R2	
D101 or ZENER D	UDZ5.1B	224490510R2	
D460 C-DIODE	1SS352	223234R2	
D460 or C-DIODE	1SS355	223269R2	
D601 C-DIODE	1SS226	223266R2	<MUP>
D602 C-DIODE	1SS226	223266R2	<MUP>
D901 ZENER D	UDZS5.1B	224550510R2	
D901 or ZENER D	UDZ5.1B	224490510R2	
D920 ZENER D	UDZS11B	224551100R2	
D921 C-DIODE	1SS352	223234R2	
D921 or C-DIODE	1SS355	223269R2	
D922 C-DIODE	1SS352	223234R2	
D922 or C-DIODE	1SS355	223269R2	
D923 C-DIODE	1SS352	223234R2	
D923 or C-DIODE	1SS355	223269R2	
D924 C-DIODE	1SS352	223234R2	
D924 or C-DIODE	1SS355	223269R2	
L351 EMIFIL	BK1608LM182-T	230958R1	
L351 or EMIFIL	FBM-10-160808-202T	230968R1	
L352 EMIFIL	BK1608LM182-T	230958R1	
L352 or EMIFIL	FBM-10-160808-202T	230968R1	
L353 EMIFIL	BK1608LM182-T	230958R1	
L353 or EMIFIL	FBM-10-160808-202T	230968R1	
L354 EMIFIL	BK1608LM182-T	230958R1	
L354 or EMIFIL	FBM-10-160808-202T	230968R1	
L601 EMIFIL	BK1608LM182-T	230958R1	<MUP>
P104 SOCKET	NSCT-7P2241	25052344	
P104 or SOCKET	NSCT-7P1676	25051889	
P104 or SOCKET	NSCT-7P2425	25052528	
P601 SOCKET	NSCT-21P2176, SCART	25052279	<MUP>
P601 or SOCKET	NSCT-21P2602, SCART	25052706	<MUP>
P701A SOCKET	NSCT-18P2409	25052512	
P701Aor SOCKET	NSCT-18P1729	25051942	
P701Aor SOCKET	NSCT-18P2215	25052318	
P351A SOCKET AS	NSAS-4P1147	2009990786UL	N
P901 SOCKET AS	NSAS-30P1102	2004C193060UL	
P201 PIN JACK, S-Terminal	NPJ-5PDBY456	25045656	
P203 PIN JACK, Video out	NPJ-3PDGLR454	25045654	Except <MUP>
P350 PIN JACK, Coaxial out	NPJ-1PDOR369	25045548	
P352 PIN JACK , RI	NPJ-2PDB400	25045589	
P401 PIN JACK, Audio out	NPJ-3PDBRW455	25045655	
Q351 PHT CP, Optical out	TOTX179L	24120102	
Q352 IC	TC74VHCU04FT	22274004HR2O	
Q401 IC	NJM4580M-D	22241448R2	
Q402 IC	NJM4580M-D	22241448R2	
Q403 IC	NJM4580M-D	22241448R2	
Q404 IC	NJM4580M-D	22241448R2	
Q601 IC	TC4053BF	222840531R2O	<MUP>
Q405 TR	HN1C03F-B	2216141R2	
Q406 TR	HN1C03F-B	2216141R2	
Q407 TR	HN1C03F-B	2216141R2	
Q460 TR	DTA114YKA	2216480R2	
Q460 or TR	RN2407	2216360R2	
Q460 or TR	KRA107S	2216350R2	
Q463 TR	DTC114YKA	2216470R2	

Q463 or	TR	RN1407	2216260R2	
Q463 or	TR	KRC107S	2216340R2	
Q602	TR	KRC102S	2216190R2	<MUP>
Q602 or	TR	RN1402	2214470R2	<MUP>
Q603	TR	KRC102S	2216190R2	<MUP>
Q603 or	TR	RN1402	2214470R2	<MUP>
Q604	TR	KTC3875-Y	2216174R2	<MUP>
Q604 or	TR	KTC3875-GR	2216175R2	<MUP>
Q604 or	TR	2SC2712-Y	2213144R2	<MUP>
Q604 or	TR	2SC2712-GR	2213145R2	<MUP>
Q605	TR	KTC3875-Y	2216174R2	<MUP>
Q605 or	TR	KTC3875-GR	2216175R2	<MUP>
Q605 or	TR	2SC2712-Y	2213144R2	<MUP>
Q605 or	TR	2SC2712-GR	2213145R2	<MUP>
Q606	TR	KTA1504-GR	2216185R2	<MUP>
Q606 or	TR	2SA1162-Y	2214374R2	<MUP>
Q606 or	TR	2SA1162-GR	2214375R2	<MUP>
Q607	TR	HN1A01F-GR	2215915R2	<MUP>
Q608	TR	HN1A01F-GR	2215915R2	<MUP>
Q920	TR	KTC3875-GR	2216175R2	
Q920 or	TR	2SC2712-GR	2213145R2	
R1001	C-CARBON R	RN72K1J-000JE	435030004R1	
R1002	C-CARBON R	RN72K1J-000JE	435030004R1	
R1003	C-CARBON R	RN72K1J-000JE	435030004R1	
R1004	C-CARBON R	RN72K1J-000JE	435030004R1	
R1005	C-CARBON R	RN72K1J-000JE	435030004R1	
R1006	C-CARBON R	RN72K1J-000JE	435030004R1	
R1007	C-CARBON R	RN72K1J-000JE	435030004R1	
R1008	C-CARBON R	RN72K1J-000JE	435030004R1	
R1009	C-CARBON R	RN72K1J-000JE	435030004R1	
R101	C-CARBON R	RN72K1J-103JE	435031034R1	
R102	C-CARBON R	RN72K1J-470JE	435034704R1	
R1010	C-CARBON R	RN72K1J-000JE	435030004R1	
R103	C-CARBON R	RN72K1J-470JE	435034704R1	
R104	C-CARBON R	RN72K1J-470JE	435034704R1	
R106	C-CARBON R	RN72K1J-470JE	435034704R1	
R107	C-CARBON R	RN72K1J-470JE	435034704R1	
R108	C-CARBON R	RN72K1J-470JE	435034704R1	
R115	C-CARBON R	RN72K1J-000JE	435030004R1	
R115	C-CARBON R	RN72K1J-000JE	435030004R1	Except <MUP>
R116	C-CARBON R	RN72K1J-000JE	435030004R1	<MUP>
R117	C-CARBON R	RN72K1J-103JE	435031034R1	
R118	C-CARBON R	RN72K1J-103JE	435031034R1	
R119	C-CARBON R	RN72K1J-103JE	435031034R1	
R121	C-CARBON R	RN72K1J-470JE	435034704R1	
R122	C-CARBON R	RN72K1J-470JE	435034704R1	
R123	C-CARBON R	RN72K1J-000JE	435030004R1	
R124	C-CARBON R	RN72K1J-470JE	435034704R1	
R125	C-CARBON R	RN72K1J-470JE	435034704R1	
R126	C-CARBON R	RN72K1J-470JE	435034704R1	
R127	C-CARBON R	RN72K1J-470JE	435034704R1	
R134	C-CARBON R	RN72K1J-103JE	435031034R1	
R135	C-CARBON R	RN72K1J-103JE	435031034R1	
R136	C-CARBON R	RN72K1J-103JE	435031034R1	
R137	C-CARBON R	RN72K1J-103JE	435031034R1	
R221	C-CARBON R	RN72K1J-750JE	435037504R1	
R222	C-CARBON R	RN72K1J-750JE	435037504R1	
R223	C-CARBON R	RN72K1J-750JE	435037504R1	
R224	C-CARBON R	RN72K1J-103JE	435031034R1	
R225	C-CARBON R	RN72K1J-750JE	435037504R1	Except <MUP>
R227	C-CARBON R	RN72K1J-750JE	435037504R1	Except <MUP>
R229	C-CARBON R	RN72K1J-750JE	435037504R1	Except <MUP>
R231	C-CARBON R	RN72K1J-000JE	435030004R1	

R232	C-CARBON R	RN72K1J-000JE	435030004R1	
R233	C-CARBON R	RN72K1J-000JE	435030004R1	
R234	C-CARBON R	RN72K1J-000JE	435030004R1	Except <MUP>
R235	C-CARBON R	RN72K1J-000JE	435030004R1	Except <MUP>
R236	C-CARBON R	RN72K1J-000JE	435030004R1	Except <MUP>
R351	C-CARBON R	RN72K1J-000JE	435030004R1	
R353	C-CARBON R	RN72K1J-474JE	435034744R1	
R354	C-CARBON R	RN72K1J-331JE	435033314R1	
R355	C-CARBON R	RN72K1J-181JE	435031814R1	
R356	C-CARBON R	RN72K1J-181JE	435031814R1	
R357	C-CARBON R	RN72K1J-471JE	435034714R1	
R401	C-CARBON R	RN72K1J-152JE	435031524R1	
R402	C-CARBON R	RN72K1J-152JE	435031524R1	
R405	C-CARBON R	RN72K1J-000JE	435030004R1	
R406	C-CARBON R	RN72K1J-000JE	435030004R1	
R407	C-CARBON R	RN72K1J-103JE	435031034R1	
R408	C-CARBON R	RN72K1J-103JE	435031034R1	
R409	C-CARBON R	RN72K1J-103JE	435031034R1	
R410	C-CARBON R	RN72K1J-103JE	435031034R1	
R411	C-CARBON R	RN72K1J-152JE	435031524R1	
R412	C-CARBON R	RN72K1J-152JE	435031524R1	
R413	C-CARBON R	RN72K1J-223JE	435032234R1	
R414	C-CARBON R	RN72K1J-223JE	435032234R1	
R415	C-CARBON R	RN72K1J-223JE	435032234R1	
R416	C-CARBON R	RN72K1J-223JE	435032234R1	
R417	C-CARBON R	RN72K1J-223JE	435032234R1	
R418	C-CARBON R	RN72K1J-223JE	435032234R1	
R419	C-CARBON R	RN72K1J-152JE	435031524R1	
R420	C-CARBON R	RN72K1J-152JE	435031524R1	
R421	C-CARBON R	RN72K1J-223JE	435032234R1	
R422	C-CARBON R	RN72K1J-223JE	435032234R1	
R423	C-CARBON R	RN72K1J-152JE	435031524R1	
R424	C-CARBON R	RN72K1J-152JE	435031524R1	
R427	C-CARBON R	RN72K1J-103JE	435031034R1	
R428	C-CARBON R	RN72K1J-103JE	435031034R1	
R429	C-CARBON R	RN72K1J-103JE	435031034R1	
R430	C-CARBON R	RN72K1J-103JE	435031034R1	
R431	C-CARBON R	RN72K1J-471JE	435034714R1	
R432	C-CARBON R	RN72K1J-471JE	435034714R1	
R433	C-CARBON R	RN72K1J-101JE	435031014R1	
R434	C-CARBON R	RN72K1J-101JE	435031014R1	
R435	C-CARBON R	RN72K1J-101JE	435031014R1	
R441	C-CARBON R	RN72K1J-104JE	435031044R1	
R442	C-CARBON R	RN72K1J-104JE	435031044R1	
R443	C-CARBON R	RN72K1J-271JE	435032714R1	
R444	C-CARBON R	RN72K1J-271JE	435032714R1	
R445	C-CARBON R	RN72K1J-222JE	435032224R1	
R446	C-CARBON R	RN72K1J-222JE	435032224R1	
R447	C-CARBON R	RN72K1J-101JE	435031014R1	
R448	C-CARBON R	RN72K1J-101JE	435031014R1	
R449	C-CARBON R	RN72K1J-222JE	435032224R1	
R450	C-CARBON R	RN72K1J-222JE	435032224R1	
R452	C-CARBON R	RN72K1J-222JE	435032224R1	
R453	C-CARBON R	RN72K1J-101JE	435031014R1	
R454	C-CARBON R	RN72K1J-222JE	435032224R1	
R455	C-CARBON R	RN72K1J-104JE	435031044R1	
R456	C-CARBON R	RN72K1J-104JE	435031044R1	
R457	C-CARBON R	RN72K1J-104JE	435031044R1	
R458	C-CARBON R	RN72K1J-154JE	435031544R1	
R459	C-CARBON R	RN72K1J-154JE	435031544R1	
R460	C-CARBON R	RN72K1J-154JE	435031544R1	
R461	C-CARBON R	RN72K1J-154JE	435031544R1	
R462	C-CARBON R	RN72K1J-102JE	435031024R1	

R463	C-CARBON R	RN72K1J-102JE	435031024R1	
R481	NF CARBON R	R25J-2.2	415470224	
R482	NF CARBON R	R25J-2.2	415470224	
R601	C-CARBON R	RN72K1J-182JE	435031824R1	<MUP>
R602	C-CARBON R	RN72K1J-222JE	435032224R1	<MUP>
R603	C-CARBON R	RN72K1J-222JE	435032224R1	<MUP>
R604	C-CARBON R	RN72K1J-103JE	435031034R1	<MUP>
R605	C-CARBON R	RN72K1J-103JE	435031034R1	<MUP>
R606	C-CARBON R	RN72K1J-472JE	435034724R1	<MUP>
R607	C-CARBON R	RN72K1J-122JE	435031224R1	<MUP>
R608	C-CARBON R	RN72K1J-223JE	435032234R1	<MUP>
R609	C-CARBON R	RN72K1J-563JE	435035634R1	<MUP>
R610	C-CARBON R	RN72K1J-680JE	435036804R1	<MUP>
R612	METAL O R	RS1/2WBJ-330	443523314	<MUP>
R613	METAL O R	RS1/2WBJ-330	443523314	<MUP>
R614	C-CARBON R	RN72K1J-102JE	435031024R1	<MUP>
R615	C-CARBON R	RN72K1J-103JE	435031034R1	<MUP>
R616	C-CARBON R	RN72K1J-101JE	435031014R1	<MUP>
R617	C-CARBON R	RN72K1J-101JE	435031014R1	<MUP>
R618	C-CARBON R	RN72K1J-750JE	435037504R1	<MUP>
R619	C-CARBON R	RN72K1J-750JE	435037504R1	<MUP>
R620	C-CARBON R	RN72K1J-750JE	435037504R1	<MUP>
R621	C-CARBON R	RN72K1J-750JE	435037504R1	<MUP>
R622	C-CARBON R	RN72K1J-000JE	435030004R1	<MUT>
R623	C-CARBON R	RN72K1J-000JE	435030004R1	<MUT>
R624	C-CARBON R	RN72K1J-000JE	435030004R1	<MUT>
R625	C-CARBON R	RN72K1J-000JE	435030004R1	<MUT>
R626	C-CARBON R	RN72K1J-000JE	435030004R1	<MUT>
R902	C-CARBON R	RN72K1J-222JE	435032224R1	
R920	C-CARBON R	RN72K1J-221JE	435032214R1	
R1012	C-CARBON R	RN72K1J-000JE	435030004R1	
R1013	C-CARBON R	RN72K1J-000JE	435030004R1	
R1015	C-CARBON R	RN72K1J-000JE	435030004R1	
R1016	C-CARBON R	RN72K1J-000JE	435030004R1	
R1017	C-CARBON R	RN72K1J-000JE	435030004R1	
R1018	C-CARBON R	RN72K1J-000JE	435030004R1	
R1019	C-CARBON R	RN72K1J-000JE	435030004R1	
R1020	C-CARBON R	RN72K1J-000JE	435030004R1	

U2 : DISPLAY CIRCUIT PC BOARD NADIS-7999

CIRCUIT	PART NAME	DESCRIPTION	PART NO.	REMARK
Q701	IC	MPD780232GC-092-8BT	22242005R3	N
Q703	IC	S-80130CLMC-JIP-T2	22241924R2	
Q702	FL TUBE	HNV-13SS12T	212238	
Q704	TR	KRA103S	2216230R2	
Q704 or	TR	RN2403	2214540R2	
C701	ELECT C	CE04W6.3V-100M	355721019	
C702	C-CERA C	CK725F1E-104Z1	332161040R1	
C703	C-CERA C	CK725F1E-104Z1	332161040R1	
C704	C-CERA C	CK725F1E-104Z1	332161040R1	
C705	ELECT C	CE04W50V-22M	355782209	
C706	ELECT C	CE04W6.3V-100M	355721019	
D701	C-DIODE	1SS352	223234R2	
D701 or	C-DIODE	1SS355	223269R2	
D702	ZENER D	UDZS5.6B	224550560R2	
D703	C-DIODE	1SS352	223234R2	
D703 or	C-DIODE	1SS355	223269R2	
JL703A	WIRE HOL	NSCT-4P875	25051088	
P701B	SOCKET	NSCT-18P2436	25052539	
P701Bor	SOCKET	NSCT-18P1687	25051900	
P701Bor	SOCKET	NSCT-18P2252	25052355	
P731	SOCKET	NSCT-7P2241	25052344	

P731 or	SOCKET	NSCT-7P1676	25051889	
P731 or	SOCKET	NSCT-7P2425	25052528	
Q705	REMO SENS	RPM7138-H9	241348	N
R701	C-CARBON R	RN72K1J-103JE	435031034R1	
R702	C-CARBON R	RN72K1J-000JE	435030004R1	
R703	C-CARBON R	RN72K1J-101JE	435031014R1	
R704	C-CARBON R	RN72K1J-000JE	435030004R1	
R705	C-CARBON R	RN72K1J-000JE	435030004R1	
R706	C-CARBON R	RN72K1J-000JE	435030004R1	
R707	C-CARBON R	RN72K1J-000JE	435030004R1	
R709	C-CARBON R	RN72K1J-000JE	435030004R1	
R710	C-CARBON R	RN72K1J-103JE	435031034R1	
R711	C-CARBON R	RN72K1J-105JE	435031054R1	
R712	C-CARBON R	RN72K1J-473JE	435034734R1	
R713	C-CARBON R	RN72K1J-224JE	435032244R1	
R719	C-CARBON R	RN72K1J-103JE	435031034R1	
R723	C-CARBON R	RN72K1J-103JE	435031034R1	
R726	C-CARBON R	RN72K1J-000JE	435030004R1	
R727	C-CARBON R	RN72K1J-000JE	435030004R1	
R733	C-CARBON R	RN72K1J-102JE	435031024R1	
R734	C-CARBON R	RN72K1J-000JE	435030004R1	
R736	C-CARBON R	RN72K1J-000JE	435030004R1	
R738	C-CARBON R	RN72K1J-000JE	435030004R1	Except <MUP>
R739	C-CARBON R	RN72K1J-102JE	435031024R1	<MUP>
R740	C-CARBON R	RN72K1J-000JE	435030004R1	
R741	C-CARBON R	RN72K1J-102JE	435031024R1	<MUT> <MUS>
R742	C-CARBON R	RN72K1J-000JE	435030004R1	<MUP> <MUS>
R743	C-CARBON R	RN72K1J-102JE	435031024R1	<MDD> <MDC>
R751	C-CARBON R	RN72K1J-272JE	435032724R1	
R752	C-CARBON R	RN72K1J-391JE	435033914R1	
R753	C-CARBON R	RN72K1J-471JE	435034714R1	
R754	C-CARBON R	RN72K1J-821JE	435038214R1	
R755	C-CARBON R	RN72K1J-102JE	435031024R1	
R756	C-CARBON R	RN72K1J-182JE	435031824R1	
R758	C-CARBON R	RN72K1J-272JE	435032724R1	
R759	C-CARBON R	RN72K1J-391JE	435033914R1	
R760	C-CARBON R	RN72K1J-471JE	435034714R1	
R761	C-CARBON R	RN72K1J-821JE	435038214R1	
R762	C-CARBON R	RN72K1J-102JE	435031024R1	
R763	C-CARBON R	RN72K1J-182JE	435031824R1	
R764	C-CARBON R	RN72K1J-392JE	435033924R1	
R765	C-CARBON R	RN72K1J-103JE	435031034R1	
R766	C-CARBON R	RN72K1J-272JE	435032724R1	
R767	C-CARBON R	RN72K1J-391JE	435033914R1	
R768	C-CARBON R	RN72K1J-471JE	435034714R1	
R769	C-CARBON R	RN72K1J-821JE	435038214R1	
R770	C-CARBON R	RN72K1J-102JE	435031024R1	
R771	C-CARBON R	RN72K1J-182JE	435031824R1	
R772	C-CARBON R	RN72K1J-392JE	435033924R1	
R773	C-CARBON R	RN72K1J-103JE	435031034R1	
S701	PUSH SW	NPS-111-S681	25035718	
S702	PUSH SW	NPS-111-S681	25035718	
S703	PUSH SW	NPS-111-S681	25035718	
S704	PUSH SW	NPS-111-S681	25035718	
S705	PUSH SW	NPS-111-S681	25035718	
S706	PUSH SW	NPS-111-S681	25035718	
S707	PUSH SW	NPS-111-S681	25035718	
S708	PUSH SW	NPS-111-S681	25035718	
S709	PUSH SW	NPS-111-S681	25035718	
S710	PUSH SW	NPS-111-S681	25035718	
S712	PUSH SW	NPS-111-S681	25035718	
S713	PUSH SW	NPS-111-S681	25035718	
S714	PUSH SW	NPS-111-S681	25035718	

S715	PUSH SW	NPS-111-S681	25035718
X701	CERA LOCK	CST5.00MGW	3010242
Q702A	CUSHION	t3*10*25	28141513

U3 : STANDBY SWITCH PC BOARD NADIS-7999

CIRCUIT	PART NAME	DESCRIPTION	PART NO.	REMARK
D721	LED	SEL4110R, LED	225290	
Q708	TR	DTC114YKA	2216470R2	
Q708 or	TR	KRC107S	2216340R2	
Q708 or	TR	RN1407	2216260R2	
R757	C-CARBON R	RN72K1J-392JE	435033924R1	
R779	C-CARBON R	RN72K1J-471JE	435034714R1	
S716	PUSH SW	NPS-111-S681	25035718	

U4 : POWER SWITCH PC BOARD NASW-8000

CIRCUIT	PART NAME	DESCRIPTION	PART NO.	REMARK
C991	IS C	! RE275V-103M	3500196S	
S991	PUSH SW	! NPS-111-L666P	25035703	
S991 or	P SW	! NPS-111-L512P	25035550	
JL703B	WIRE HOL	NSCT-4P875	25051088	

U5 : INLET TERMINAL PC BOARD NAPS-8001

CIRCUIT	PART NAME	DESCRIPTION	PART NO.	REMARK
P981A	AC INLET	! NPLG-2P956	25056006	<MDD,MDC>
P981A	AC INLET	! NPLG-2P977	25056027	<MUP,MUT,MUS,MU
P982B	SOCKET AS	NSAS-2P0921	2009990661UL	

<MDD>: North American area
 <MDC>: Canadian area
 <MUT>: Southeast Asia area
 <MUK>: Korea area
 <MUS>: South America area
 <MUP>: European area
 <MUR>: China area

IR>

ONKYO CORPORATION

Sales & Product Planning Div. : 2-1, Nisshin-cho, Neyagawa-shi, OSAKA 572-8540, JAPAN
Tel: 072-831-8111 Fax: 072-833-5222

ONKYO U.S.A. CORPORATION

18 Park Way, Upper Saddle River, N.J. 07458, U.S.A.
Tel: 201-785-2600 Fax: 201-785-2650 E-mail: onkyo@onkyousa.com

ONKYO EUROPE ELECTRONICS GmbH

Liegnitzerstrasse 6, 82194 Groebenzell, GERMANY
Tel: +49-8142-4401-0 Fax: +49-8142-4401-555 E-mail: info@onkyo.de

ONKYO CHINA LIMITED

Units 2102-2107, Metroplaza Tower I, 223 Hing Fong Road, Kwai Chung,
N.T., HONG KONG Tel: 852-2429-3118 Fax: 852-2428-9039