

ONKYO SERVICE MANUAL

DVD PLAYER MODEL DV-SP504/504E

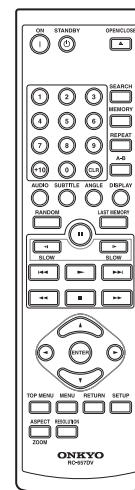
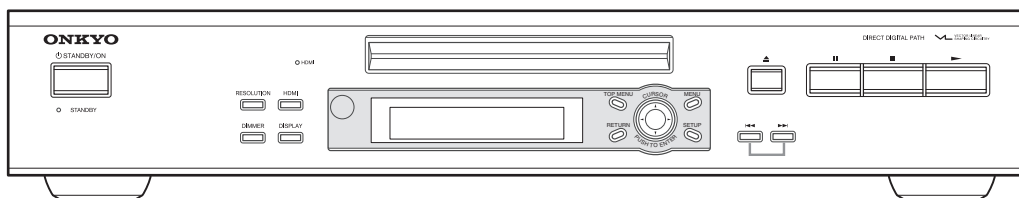

RC-657DV

Black, Silver and Golden models

BMDD, SMDD	120V AC, 60Hz
BMUP, SMUP BMUT, BMUA, BMUK SMUT, SMUA, SMUK GMUT, GMUA, GMUK	100 - 240V AC, 50/60Hz

SAFETY-RELATED COMPONENT WARNING!!

COMPONENTS IDENTIFIED BY MARK  ON THE SCHEMATIC DIAGRAM AND IN THE PARTS LIST ARE CRITICAL FOR RISK OF FIRE AND ELECTRIC SHOCK. REPLACE THESE COMPONENTS WITH ONKYO PARTS WHOSE PART NUMBERS APPEAR AS SHOWN IN THIS MANUAL.

MAKE LEAKAGE-CURRENT OR RESISTANCE MEASUREMENTS TO DETERMINE THAT EXPOSED PARTS ARE ACCEPTABLY INSULATED FROM THE SUPPLY CIRCUIT BEFORE RETURNING THE APPLIANCE TO THE CUSTOMER.

EXPLODED VIEW

CHASSIS

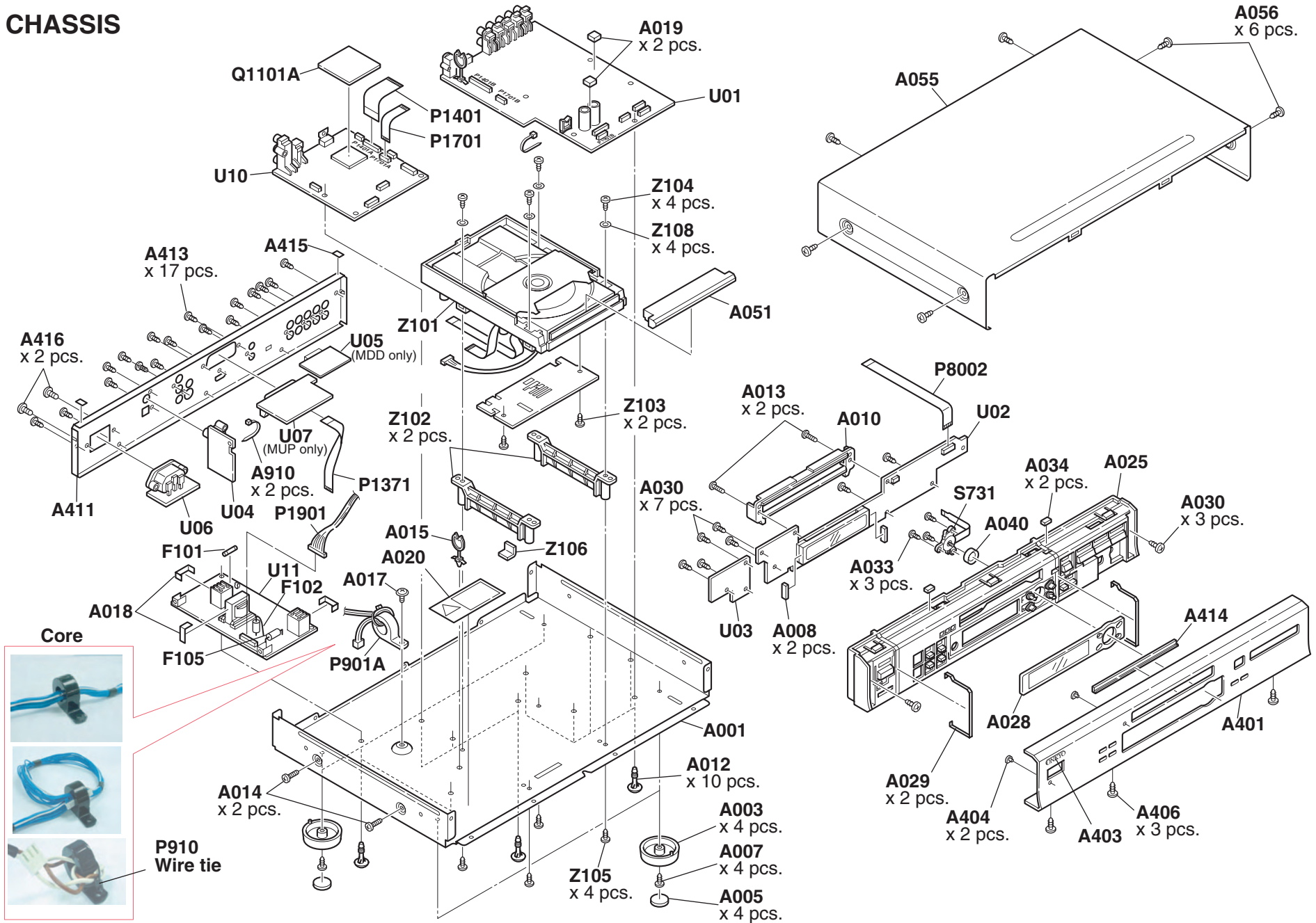

A

B

C

D

E

**EXPLODED VIEW
DVD MECHANISM**

PARTS LIST

NO.	PART NAME	PART NO.
1	Traverse Mecha. assy	C9A016
2	DamperSI-18.5	C9G011
3	Screw Dumper	C1H011
4	Guide Clamper assy	C9A013
5	Loader assy	C9A017
6	Assy Motor Load	C2A003
7	Belt Load	B9G015
8	Switch ESE22MH21	S01W204
9	Switch ESE22MH23	S01W205
10	Tray	C2G024

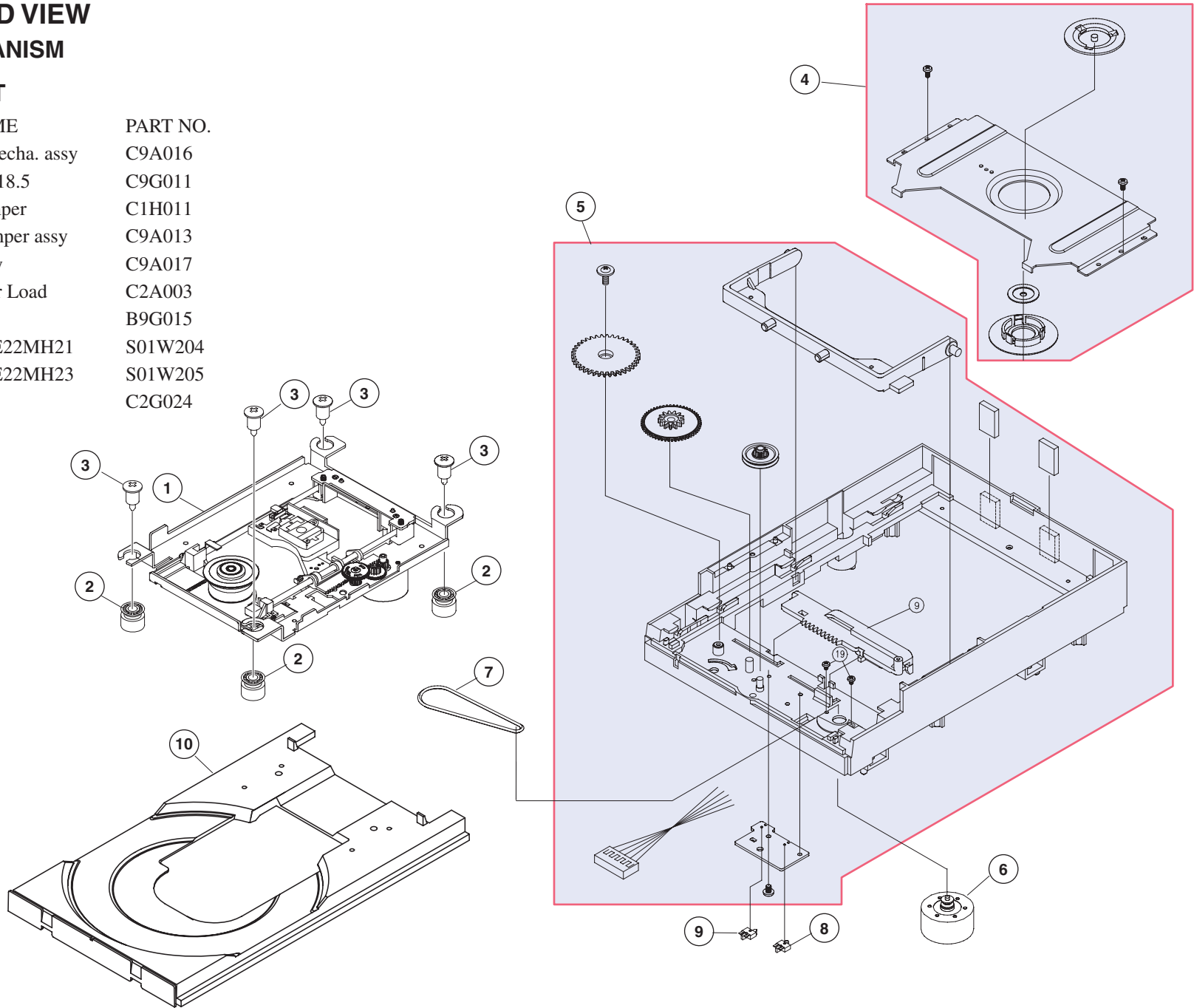

3

4

A **B** **C** **D**

BLOCK DIAGRAM

1

2

3

4

5

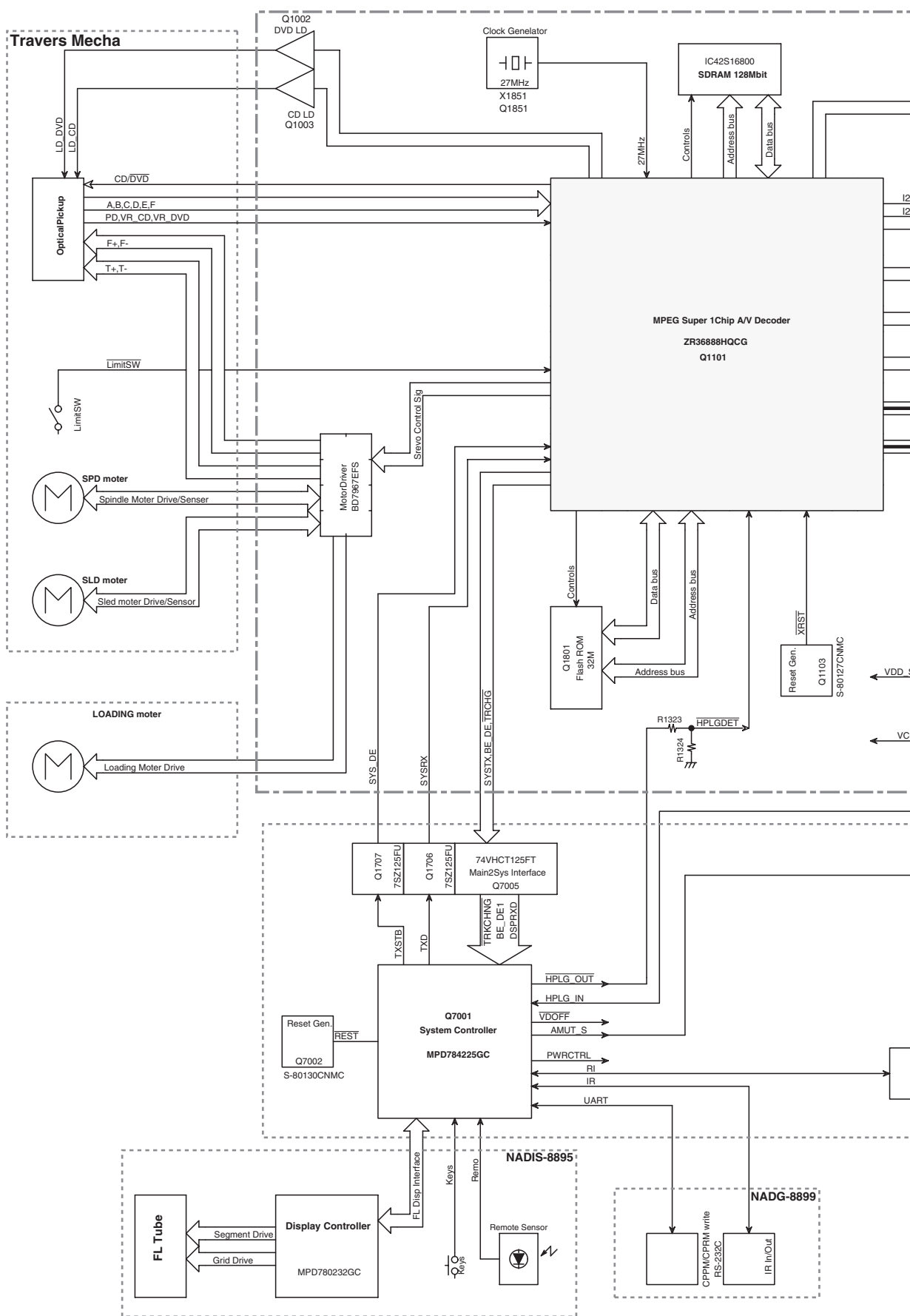

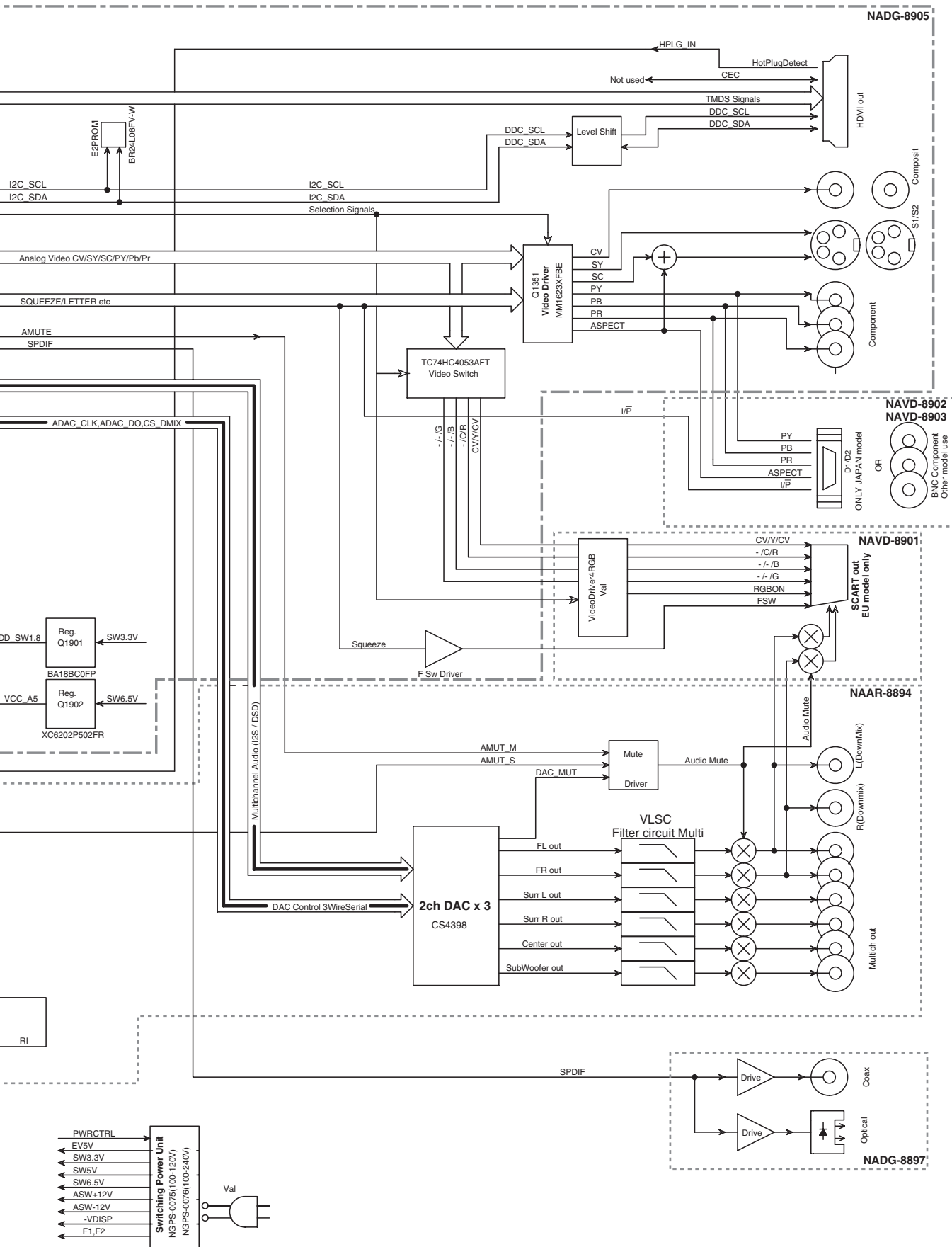

NADG-8905

NAVD-8902
NAVD-8903

NAVD-8901

NAAR-8894

NADG-8897

SCHEMATIC DIAGRAMS-1

U01 : AUDIO OUTPUT TERMINAL PC BOARD

1
2
3
4
5

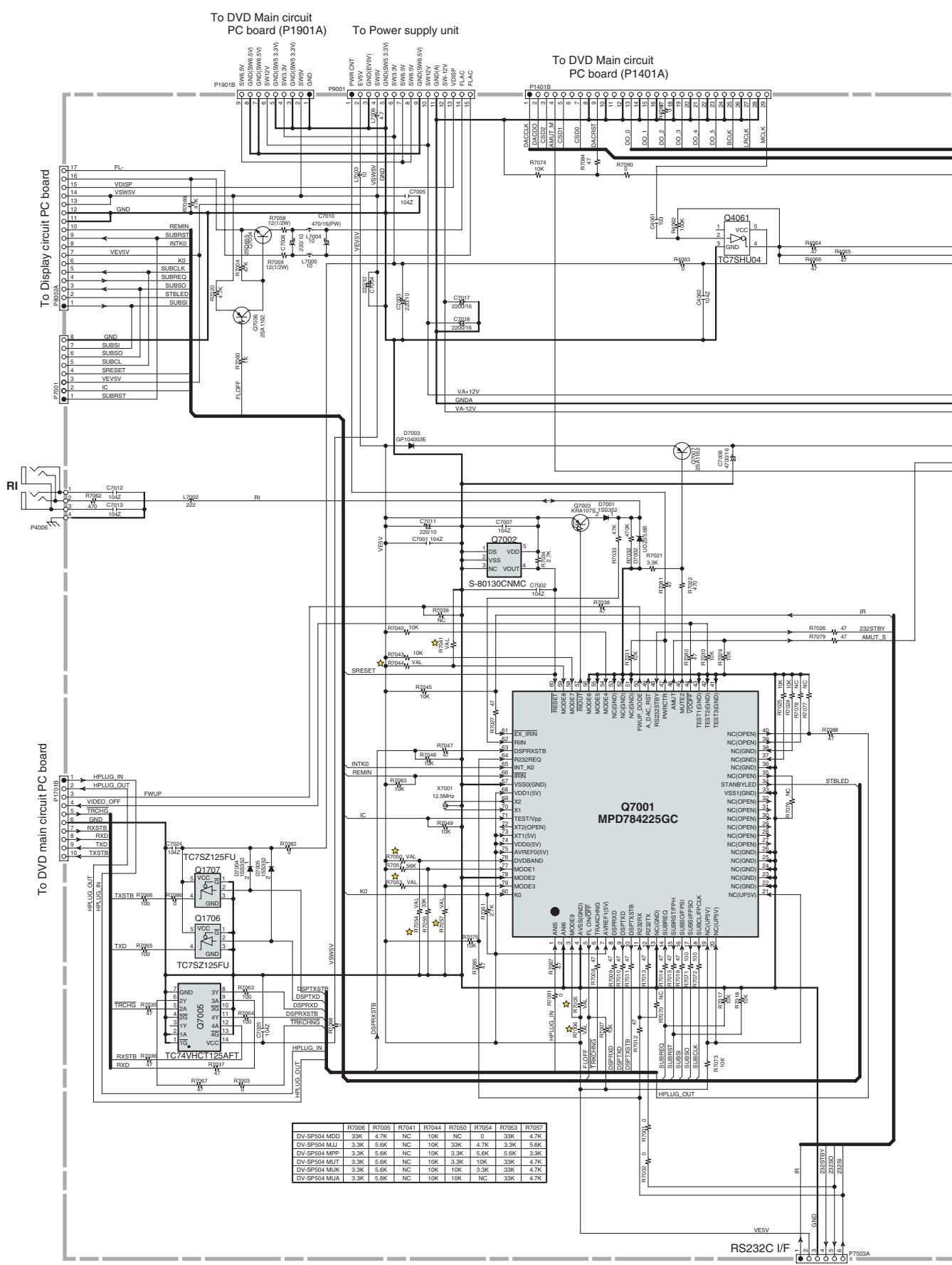

	R7006	R7005	R7041	R7044	R7050	R7054	R7053	R7057
DV-SP504 MDD	33K	4.7K	NC	10K	NC	0	33K	4.7K
DV-SP504 MJL	3.3K	5.6K	NC	10K	33K	4.7K	3.3K	5.6K
DV-SP504 MPP	3.3K	5.6K	NC	10K	3.3K	5.6K	5.6K	3.3K
DV-SP504 MUT	3.3K	5.6K	NC	10K	3.3K	10K	33K	4.7K
DV-SP504 MJK	3.3K	5.6K	NC	10K	10K	3.3K	33K	4.7K
DV-SP504 MUA	3.3K	5.6K	NC	10K	10K	NC	33K	4.7K

RS232C I/F

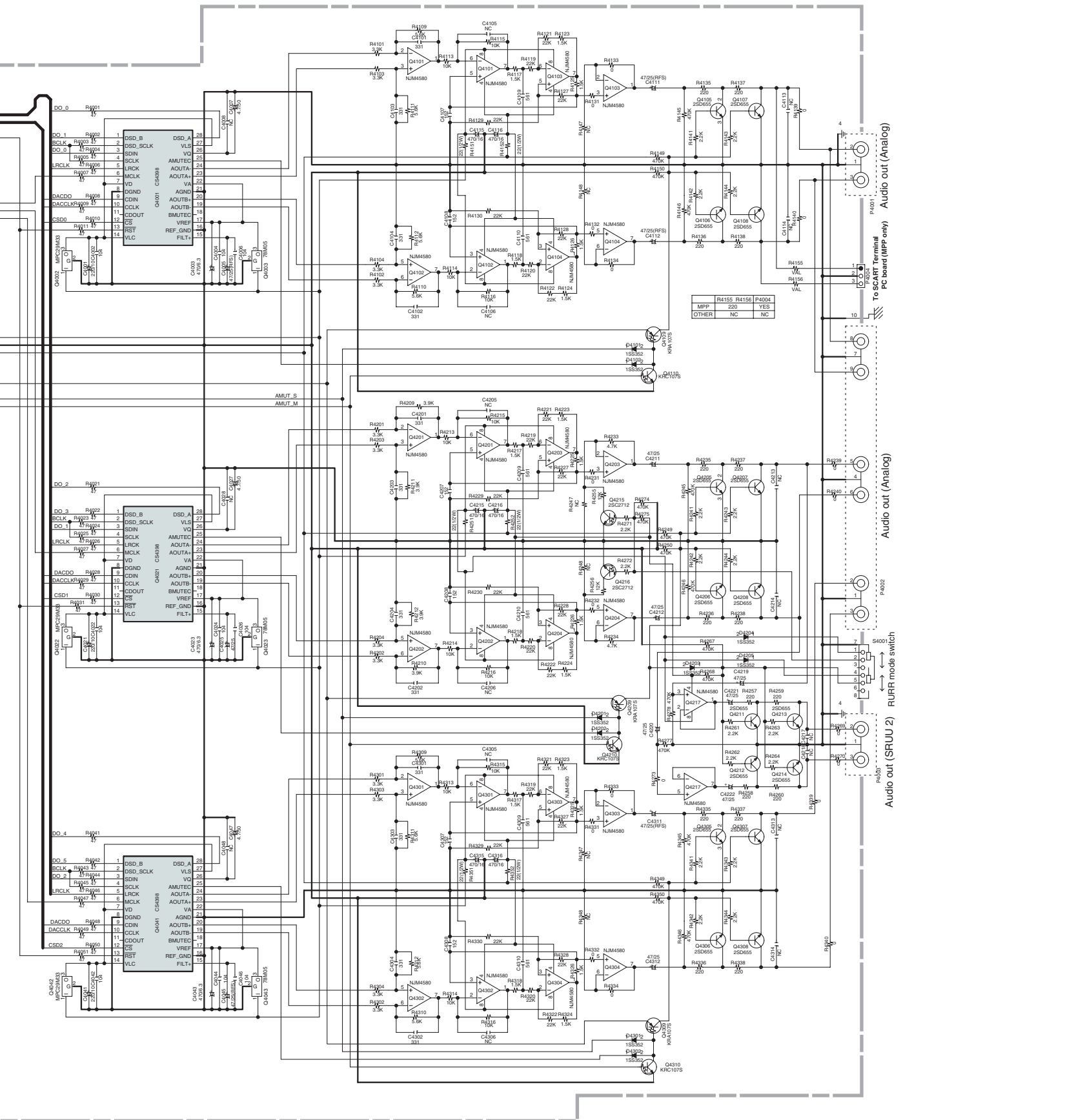

SCHEMATIC DIAGRAMS-2

U02 : DISPLAY CIRCUIT
PC BOARD
NADIS-8895

To Audio output terminal PC board

P8002B

- 17 FL
- 16 FL+SW
- 15 VDISP
- 14 SW5V
- 13 GND
- 11 REMIN
- 9 SUBRST
- 8 INTK0
- 7 E5V
- 6 K0
- 5 SUBCL
- 4 SUBREQ
- 3 SUBSI
- 2 STBLED
- 1 SUBSO

- K0
- STBLED
- INTK0
- E5V
- REMIN

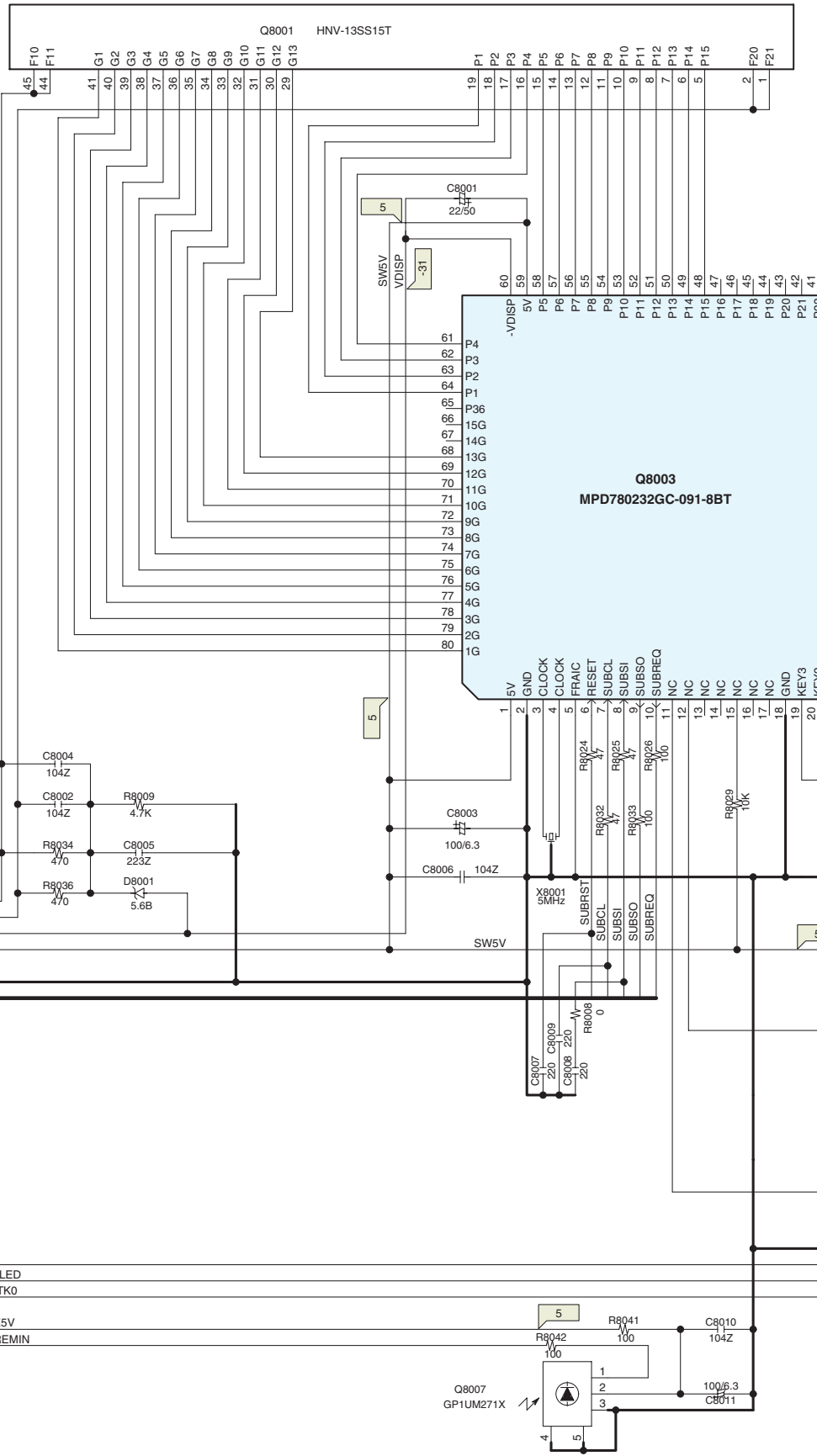

E

F

G

H

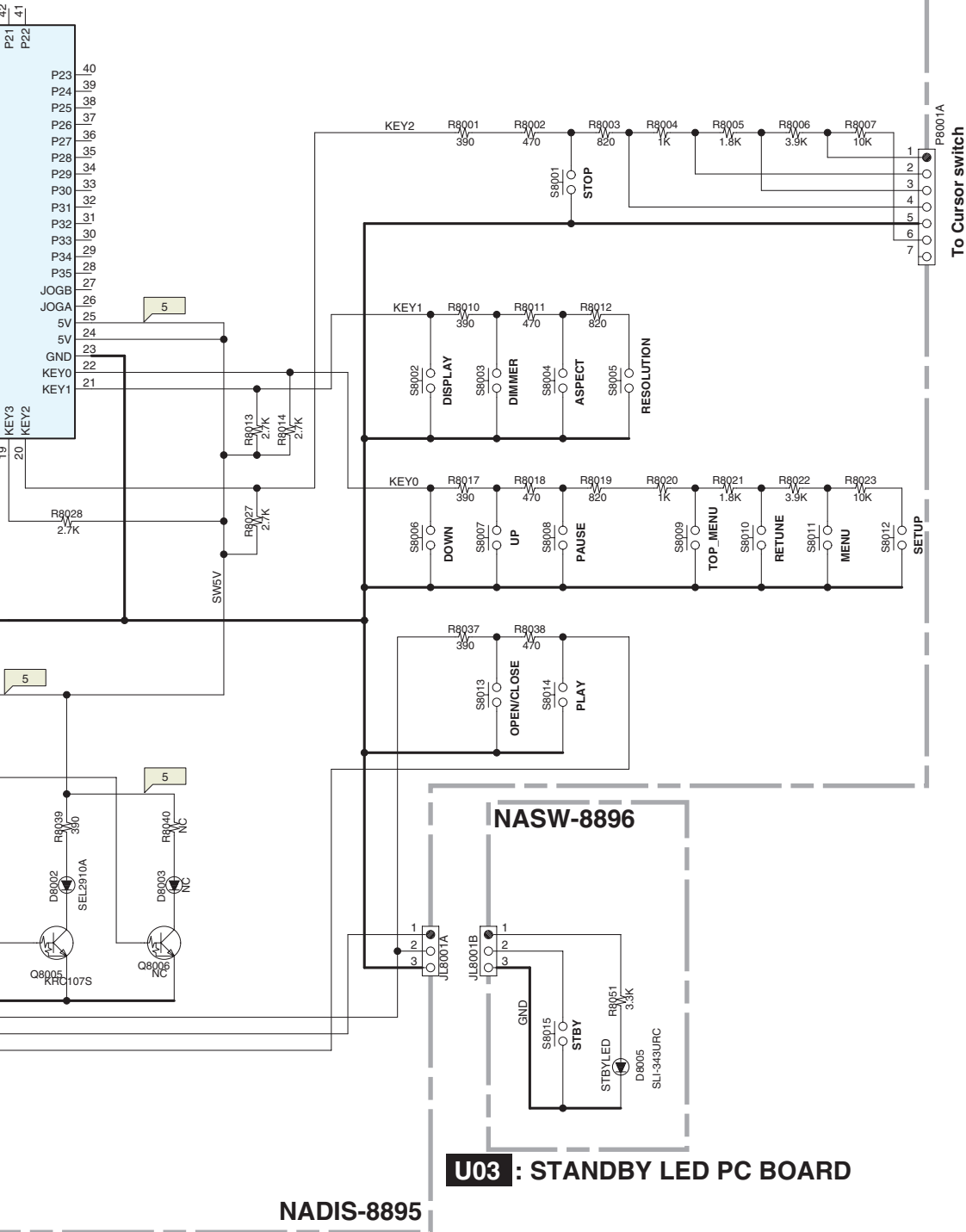

U03 : STANDBY LED PC BOARD

NADIS-8895

A **B** **C** **D**

SCHEMATIC DIAGRAMS-3

U07 : AV CONNECTOR PC BOARD

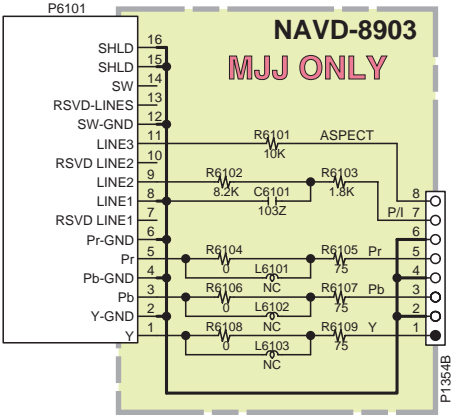
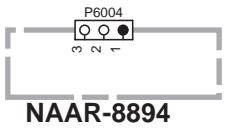
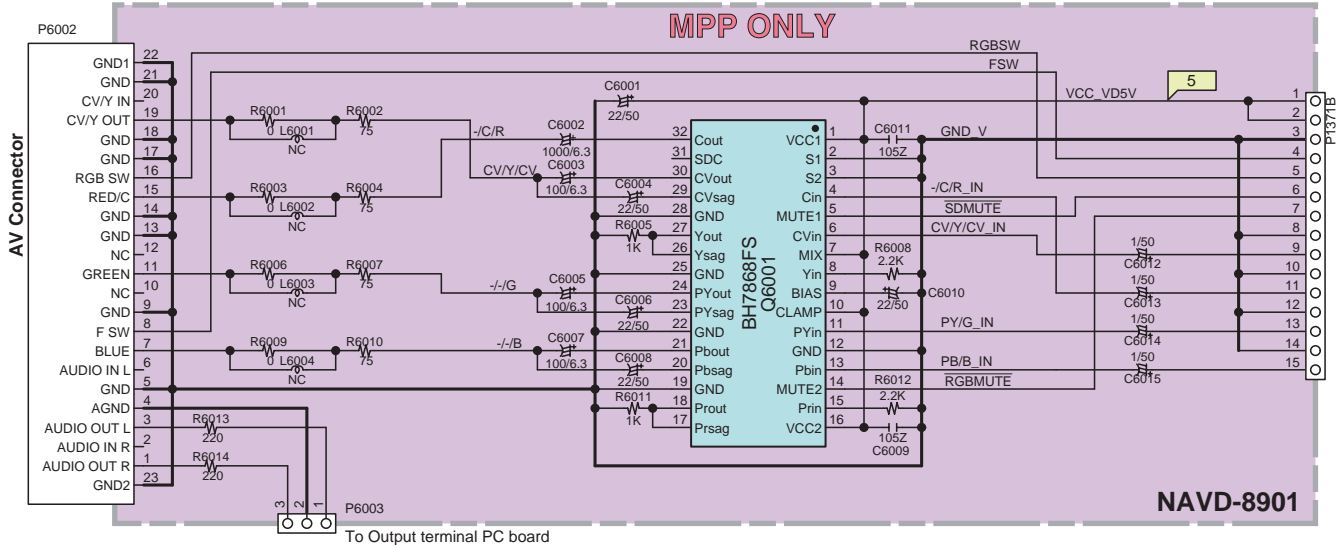

U06 : INLET TERMINAL PC BOARD

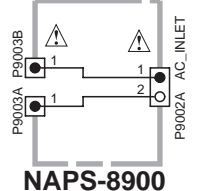

1

2

3

4

5

U10 : DVD MAIN CIRCUIT PC BOARD

NADG-8905

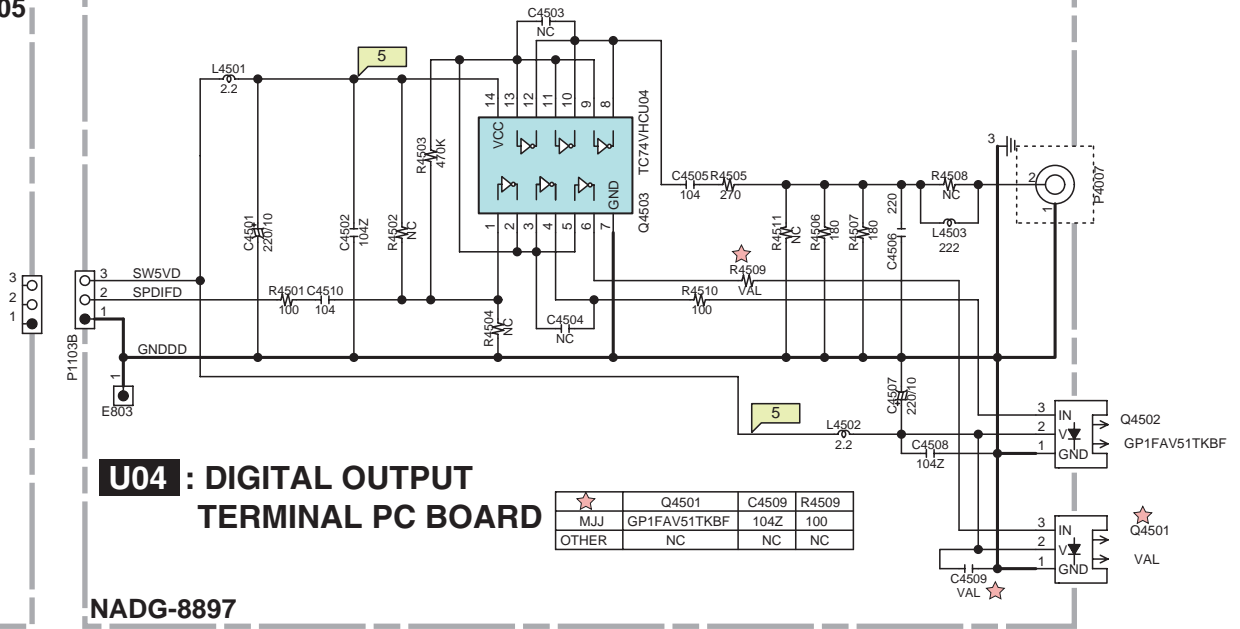

**U04 : DIGITAL OUTPUT
TERMINAL PC BOARD**

NADG-8897

NADG-8899

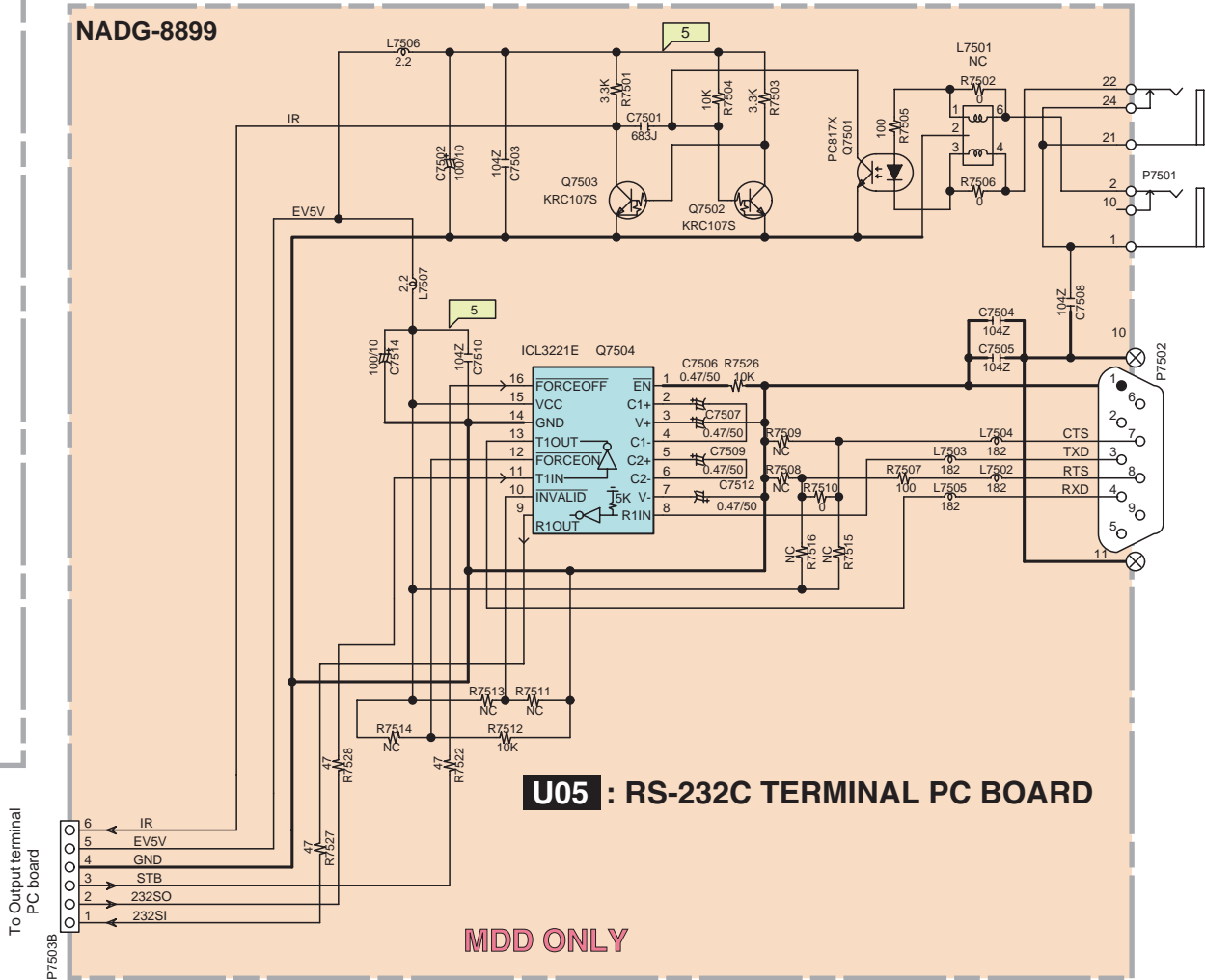

U05 : RS-232 TERMINAL PC BOARD

MDD ONLY

AR-8894

To Output terminal
PC board

P7503B

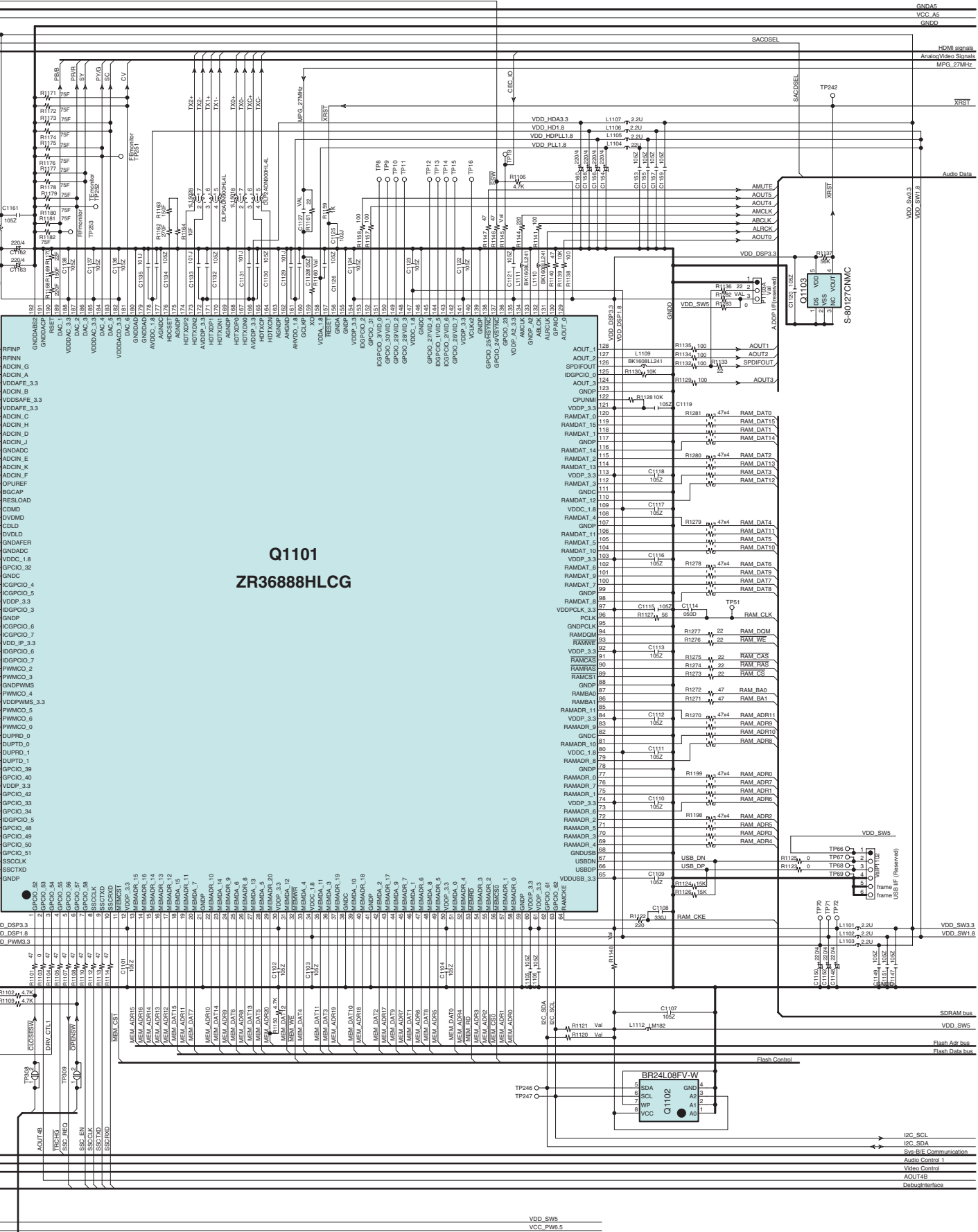

Q1101
ZR36888HLCG

SCHEMATIC DIAGRAMS-5 **U10** : DVD MAIN CIRCUIT PC BOARD-2/3

1

2

3

4

5

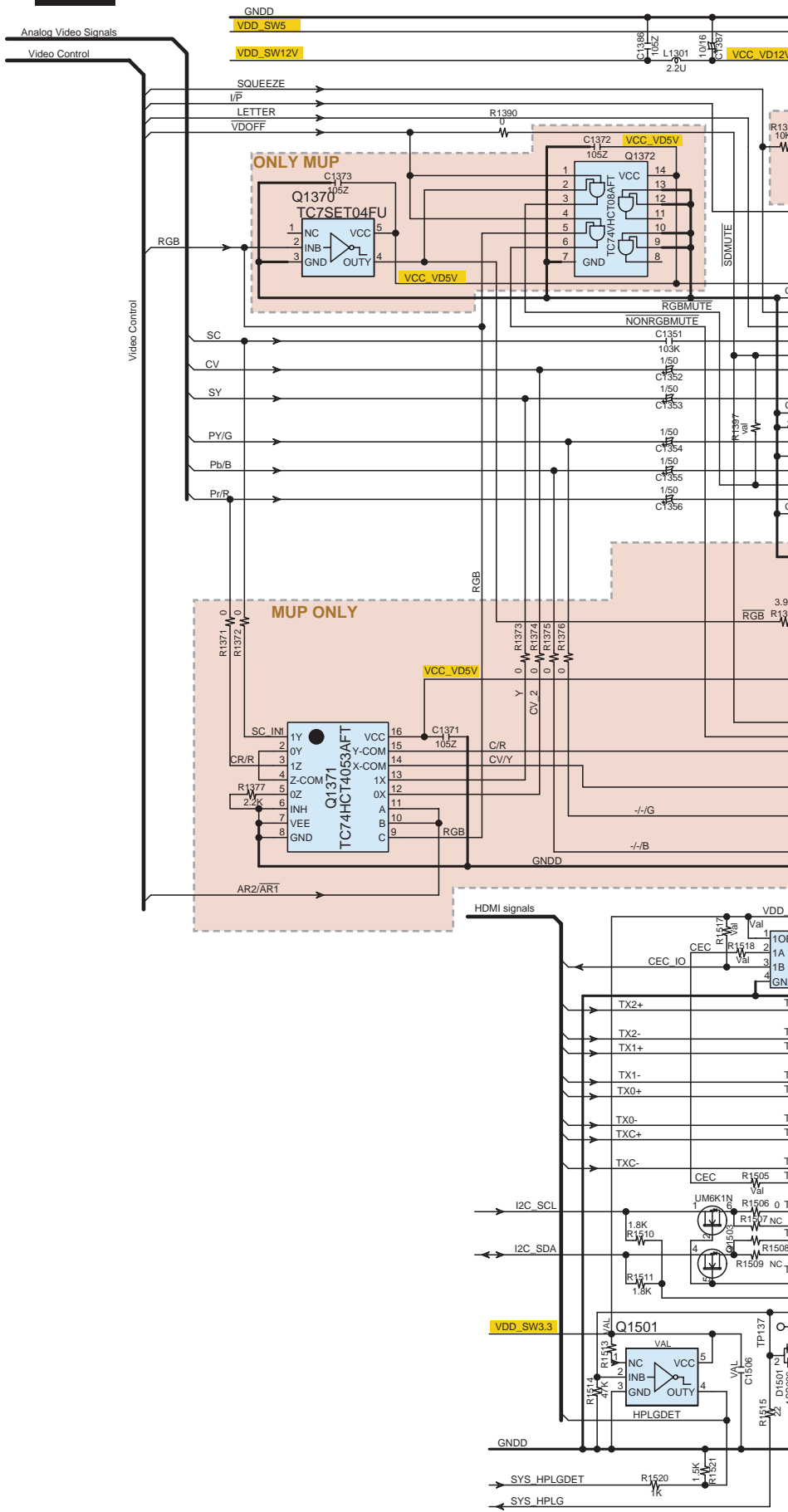

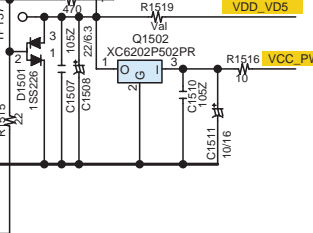
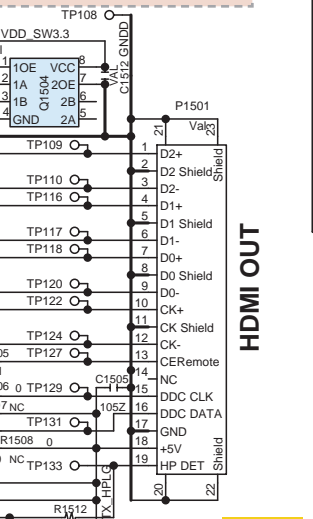
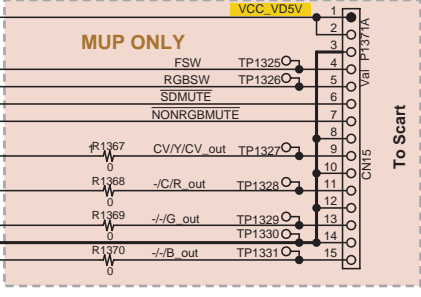
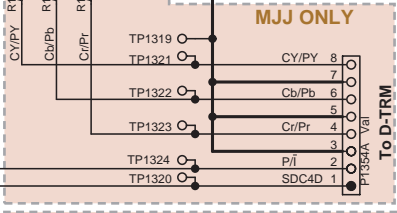
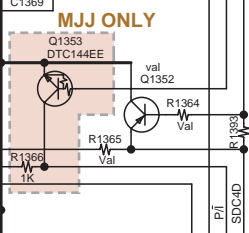
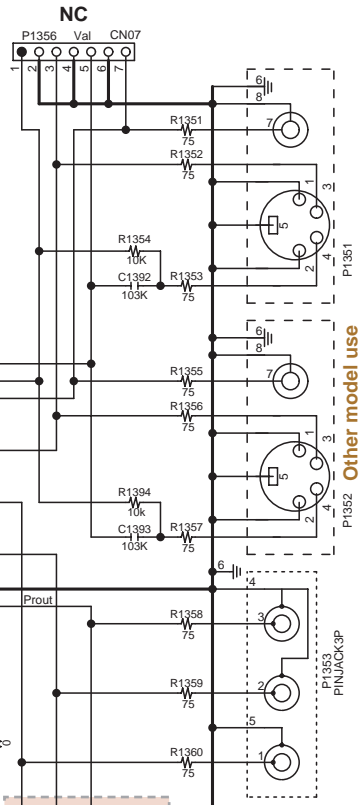
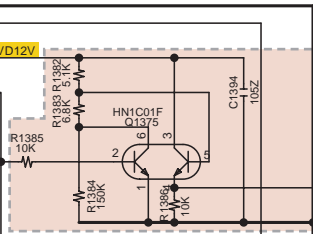
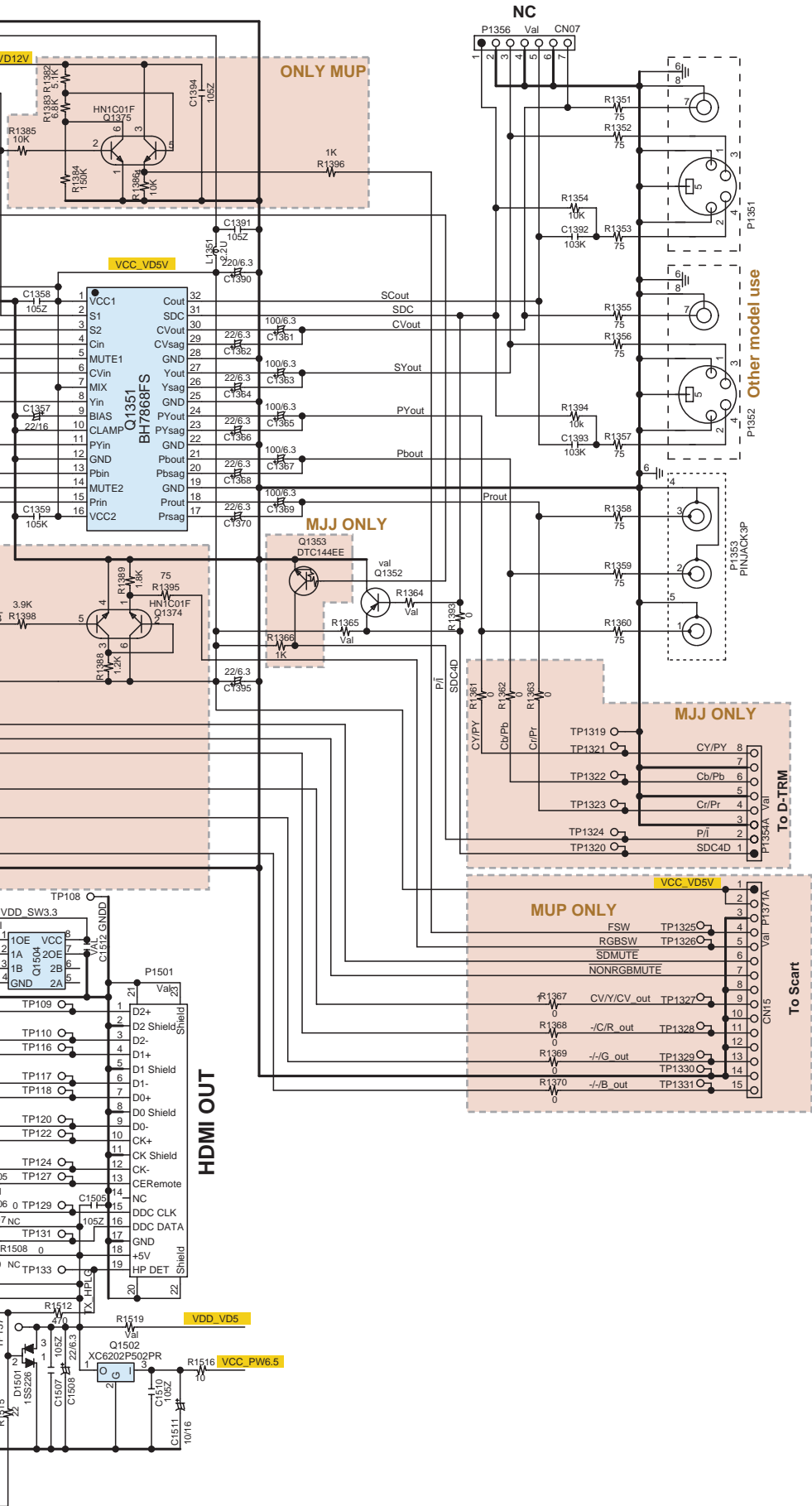

A

B

C

D

SCHEMATIC DIAGRAMS-6

U10 : DVD MAIN CIRCUIT PC BOARD-3/3 NADG-8905

1

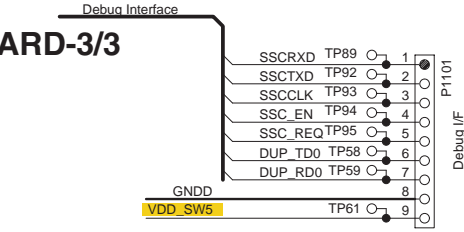

2

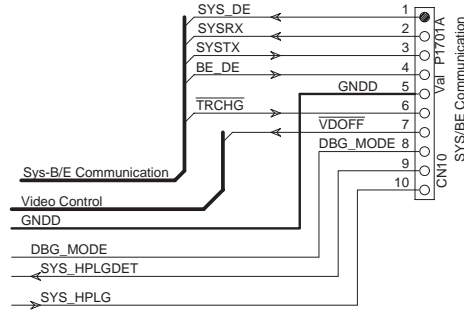

3

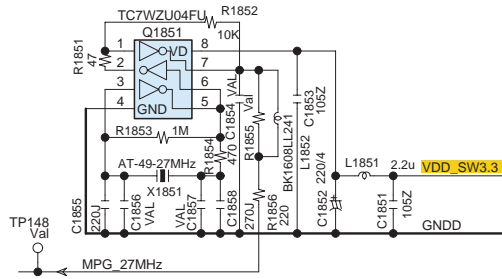

4

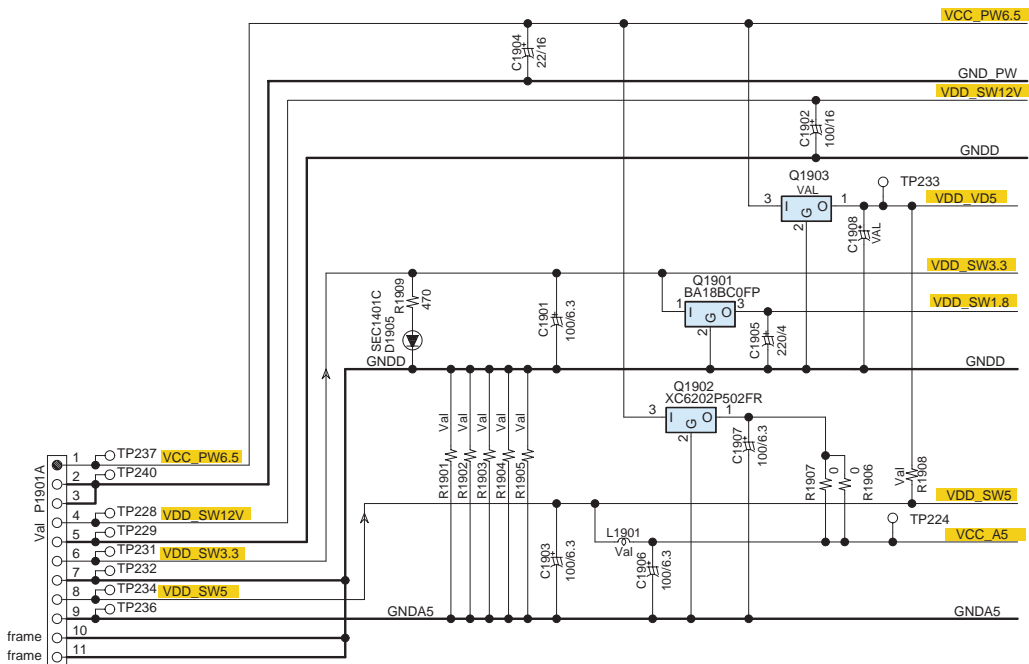

5

Audio Control 1

Audio Data

GNDD

AOUT4B R1401

DBG MODE

Flash Data bus

Flash Adr bus

VDD_S

VDD_S

MEM_AD

MEM_AD

MEM_AD

MEM_AD

MEM_AD

MEM_AD

MEM_AD

MEM_AD

MEM_AD

MEM_AD

MEM_AD

MEM_AD

MEM_AD

MEM_AD

MEM_AD

MEM_AD

MEM_AD

MEM_AD

MEM_AD

MEM_AD

MEM_AD

MEM_AD

MEM_AD

MEM_AD

MEM_AD

MEM_AD

MEM_AD

MEM_AD

MEM_AD

MEM_AD

MEM_AD

MEM_AD

MEM_AD

MEM_AD

MEM_AD

MEM_AD

MEM_AD

MEM_AD

MEM_AD

MEM_AD

MEM_AD

MEM_AD

Flash Control

E F G H

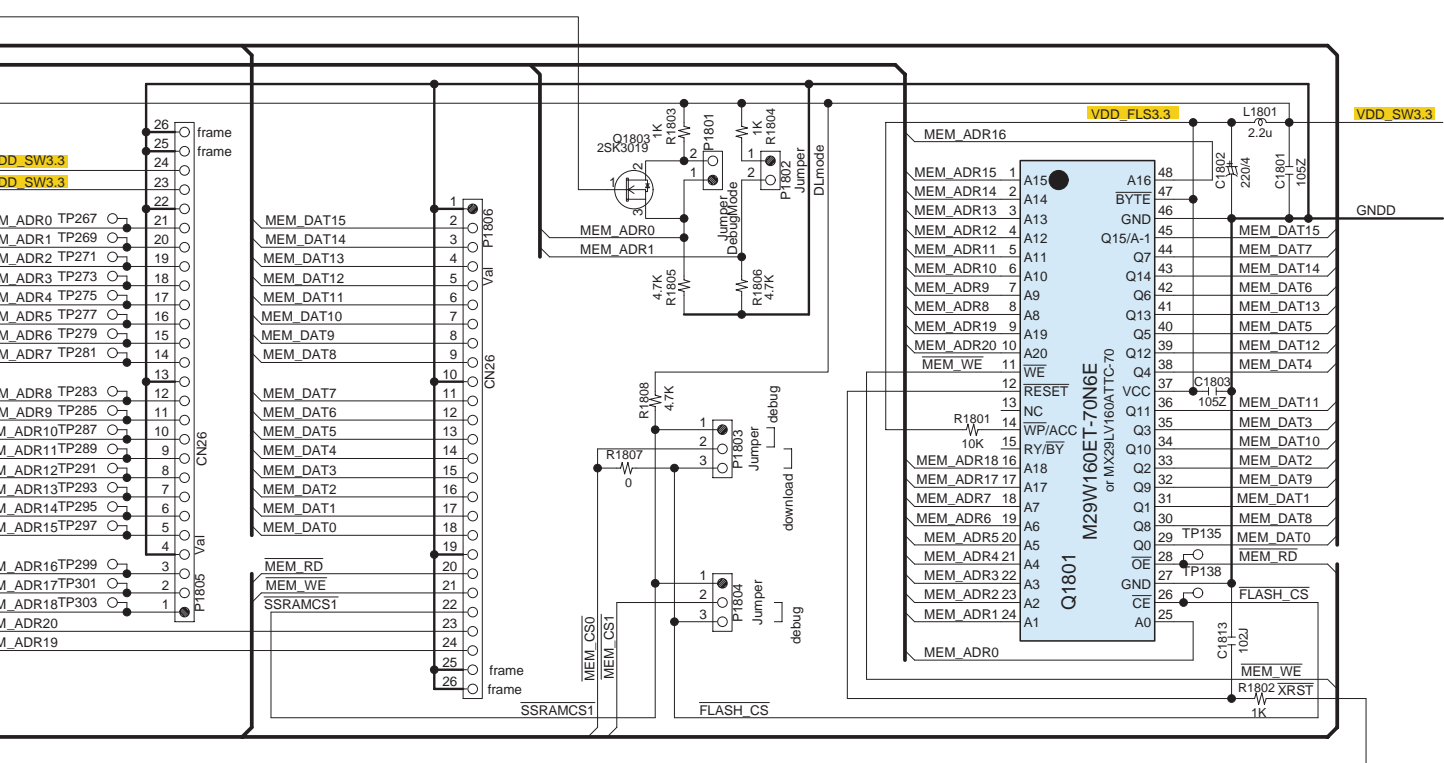
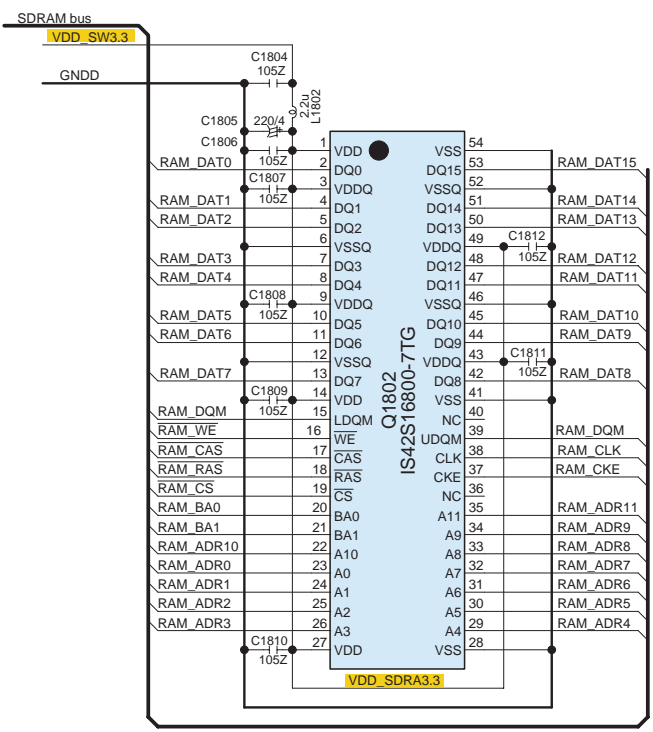
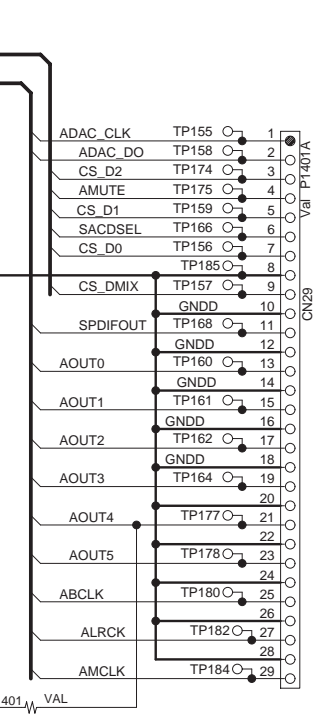

SCHEMATIC DIAGRAMS-7
U11 : Power supply unit NGPS-0074-100-120V

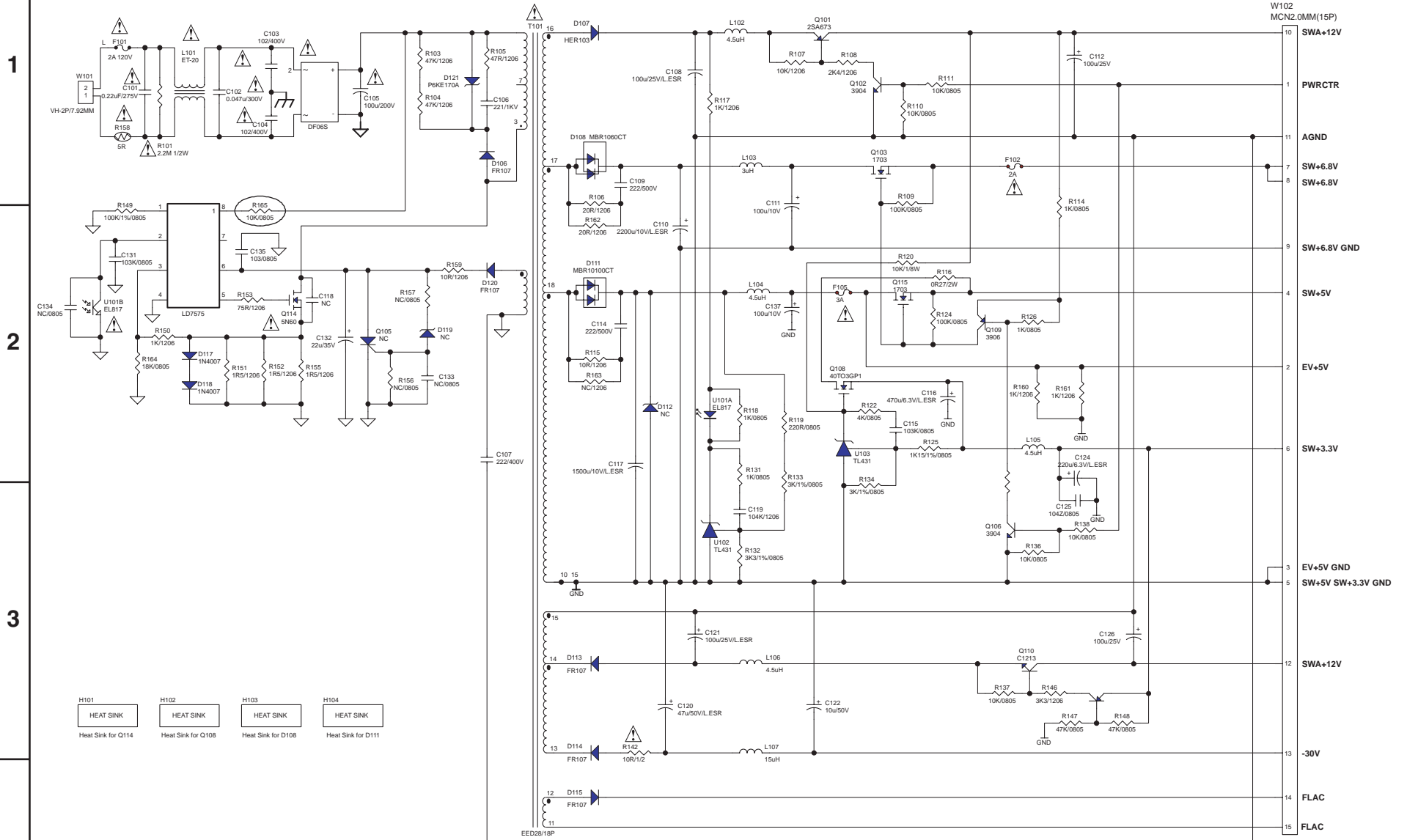

PACKING PROCEDURES

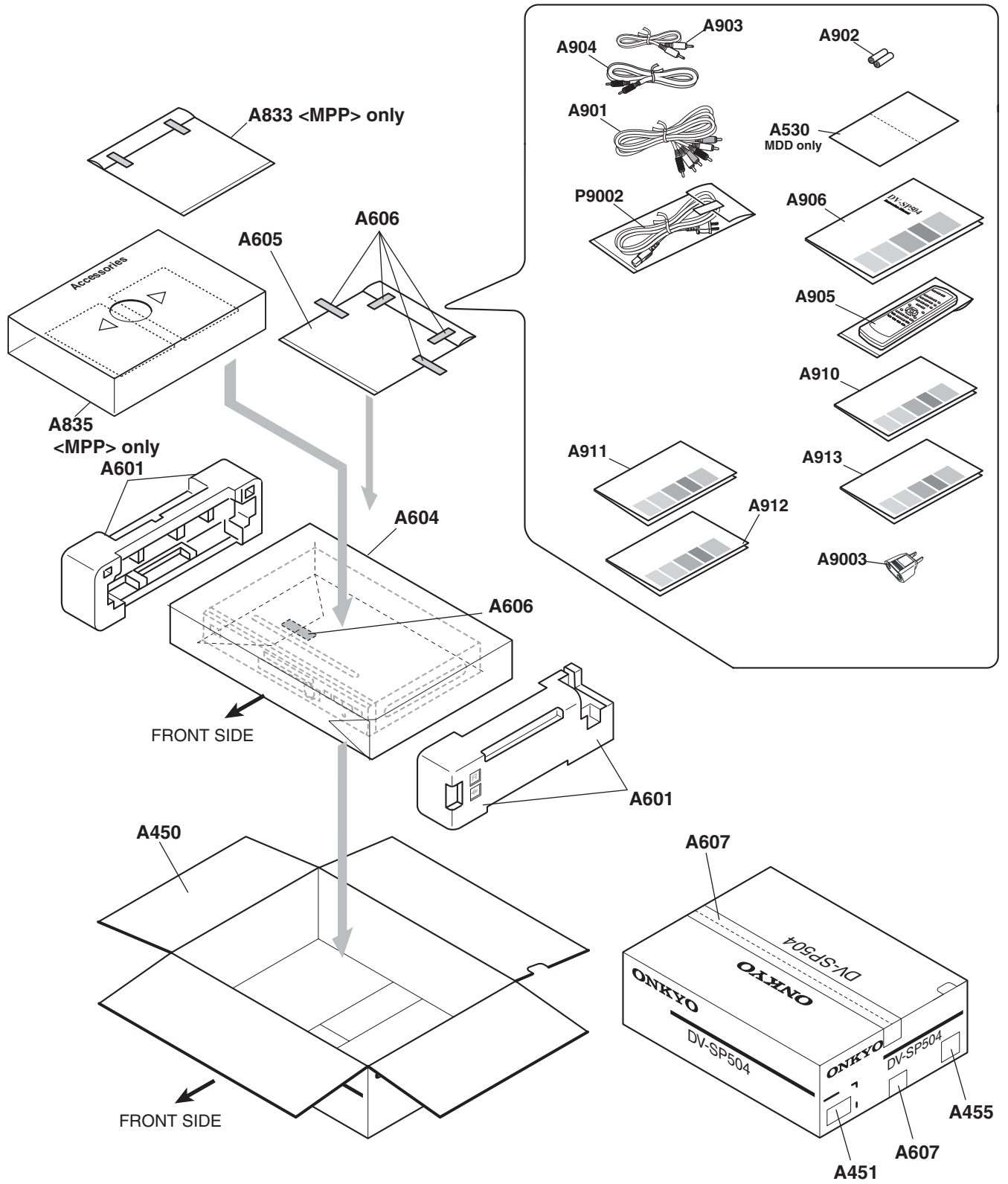

A

B

C

D

PRINTED CIRCUIT BOARD VIEWS-1

U01 Output terminal PC BOARD (NAAR-8894)

Component side

1

2

3

4

5

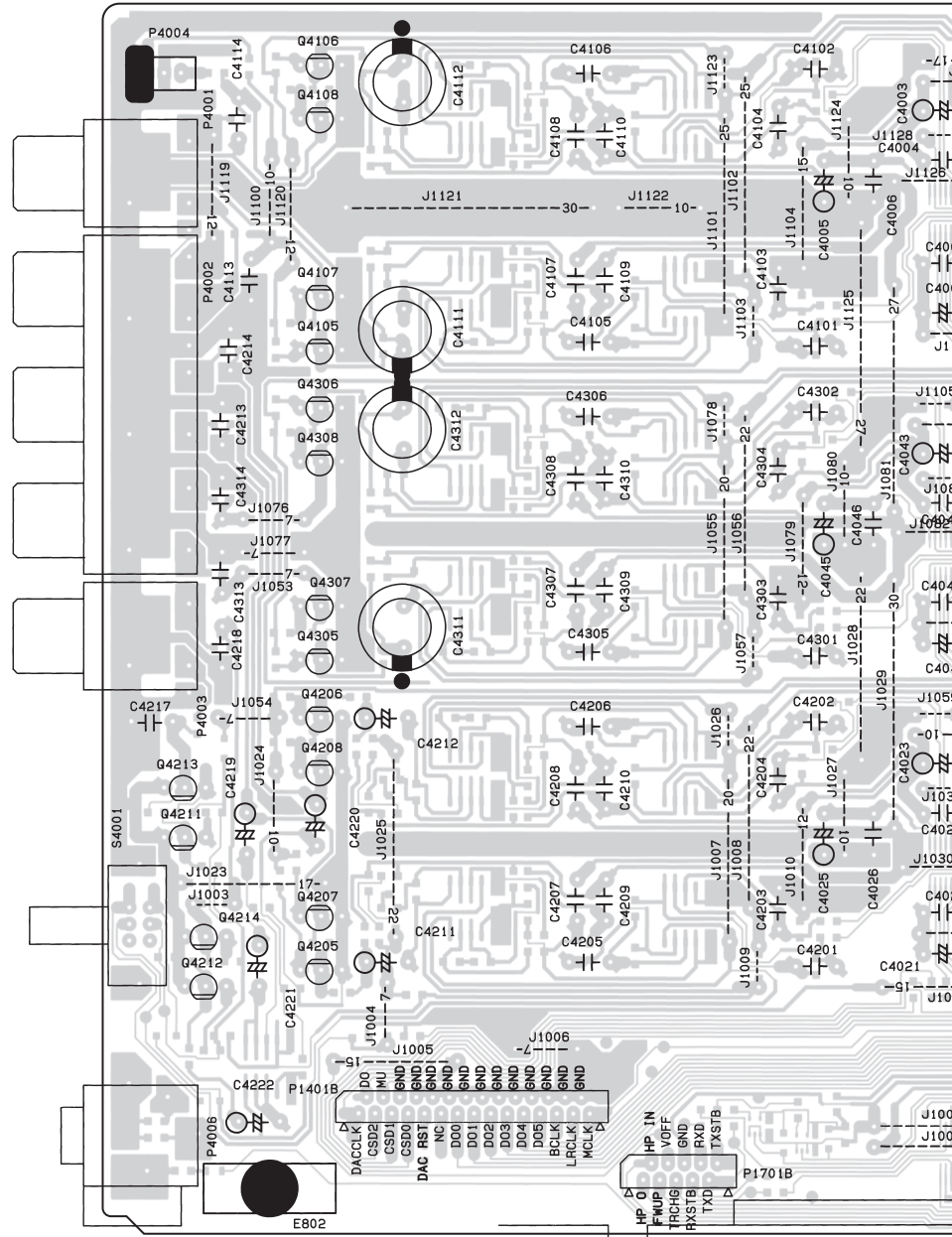

E

F

G

H

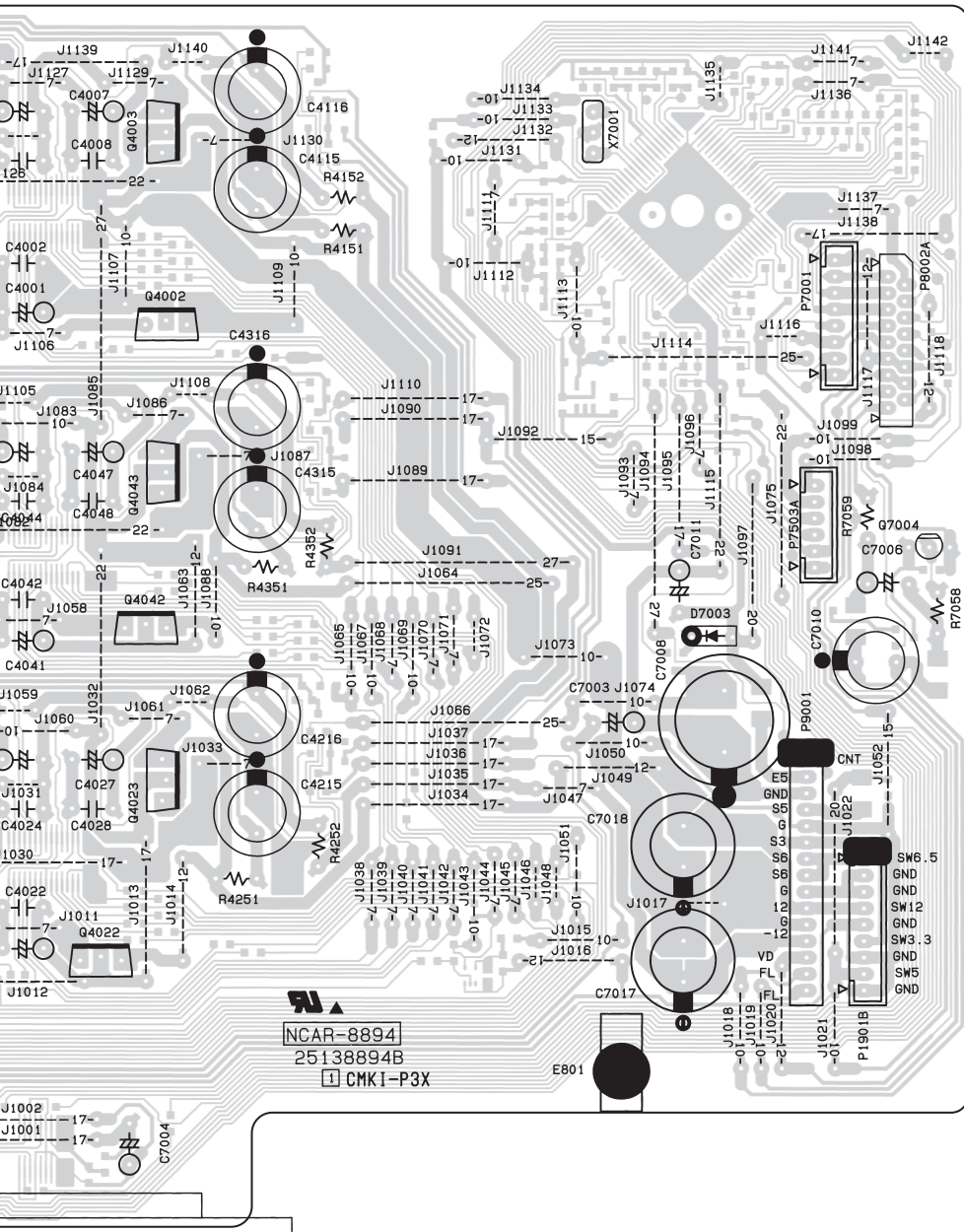

A

B

C

D

PRINTED CIRCUIT BOARD VIEWS-2

U01 Output terminal PC BOARD (NAAR-8894)
Soldering side

1

2

3

4

5

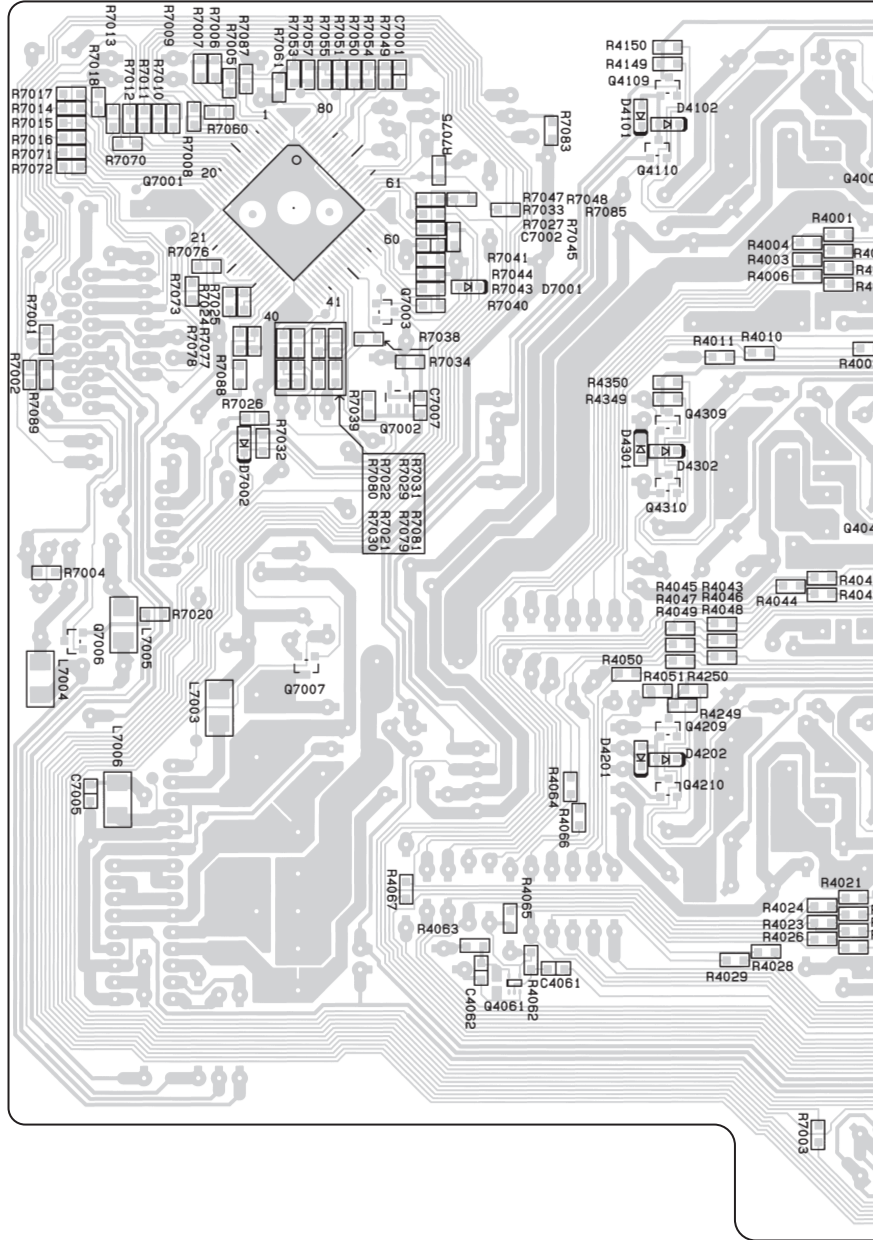

E

F

G

H

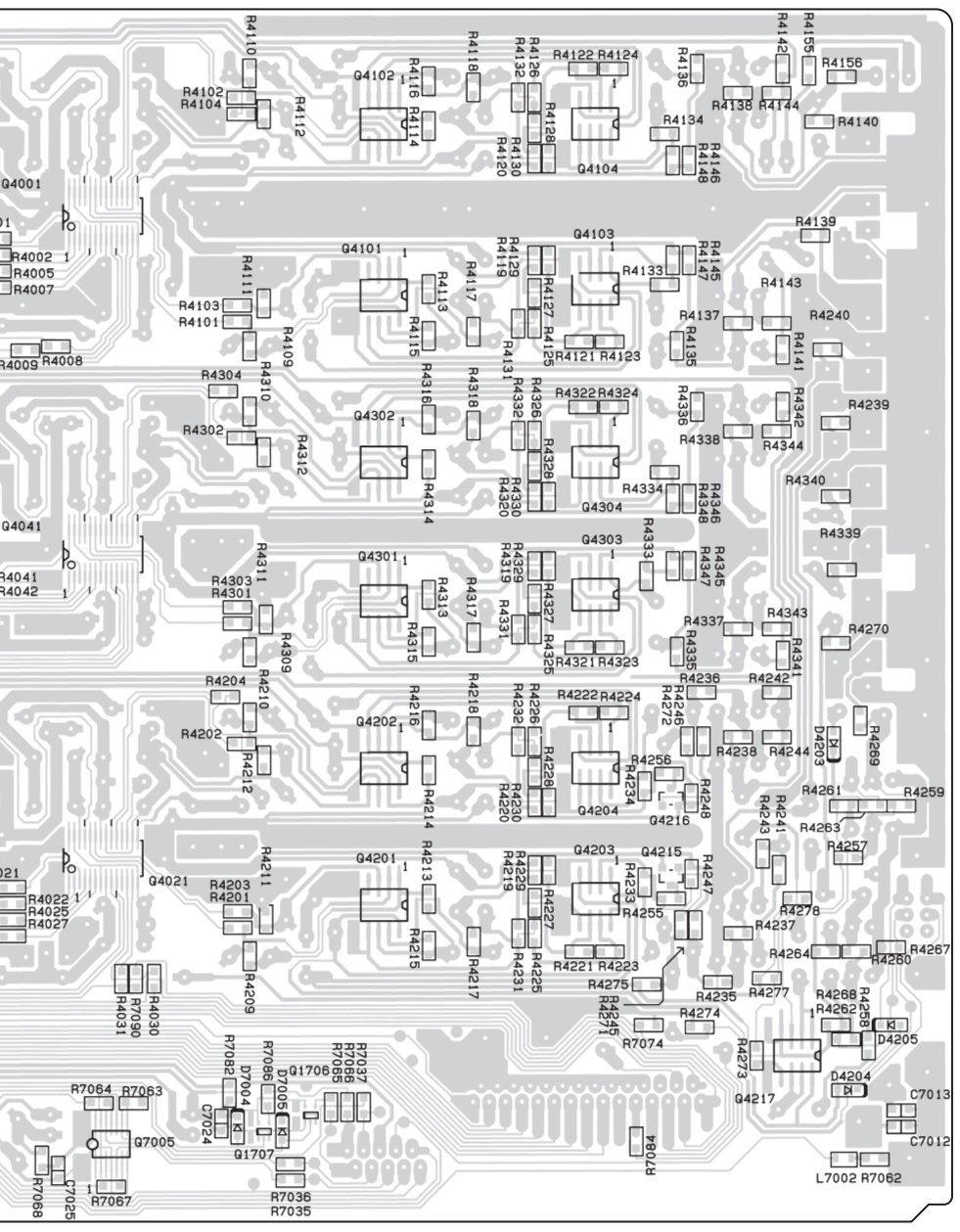

A

B

C

D

PRINTED CIRCUIT BOARD VIEWS-3

U02 Display circuit PC BOARD (NADIS-8895) Component side

1

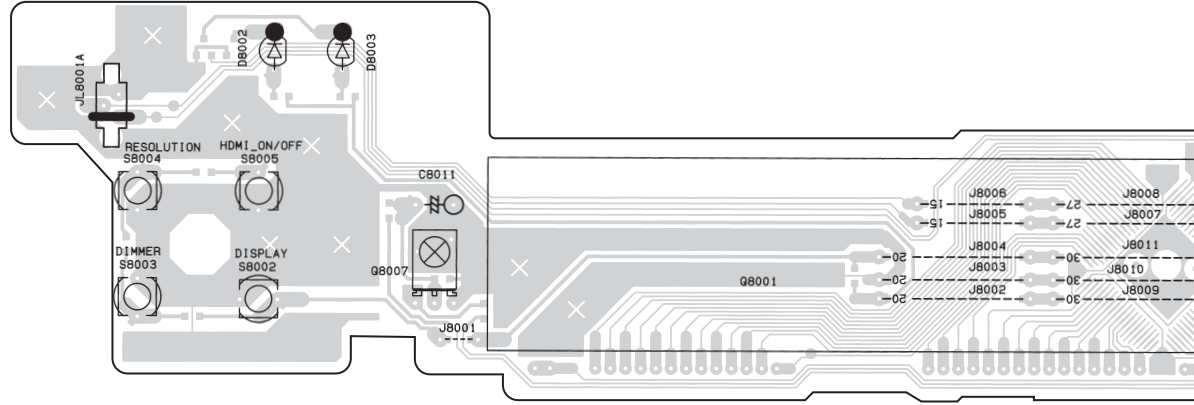

2

3

Soldering side

4

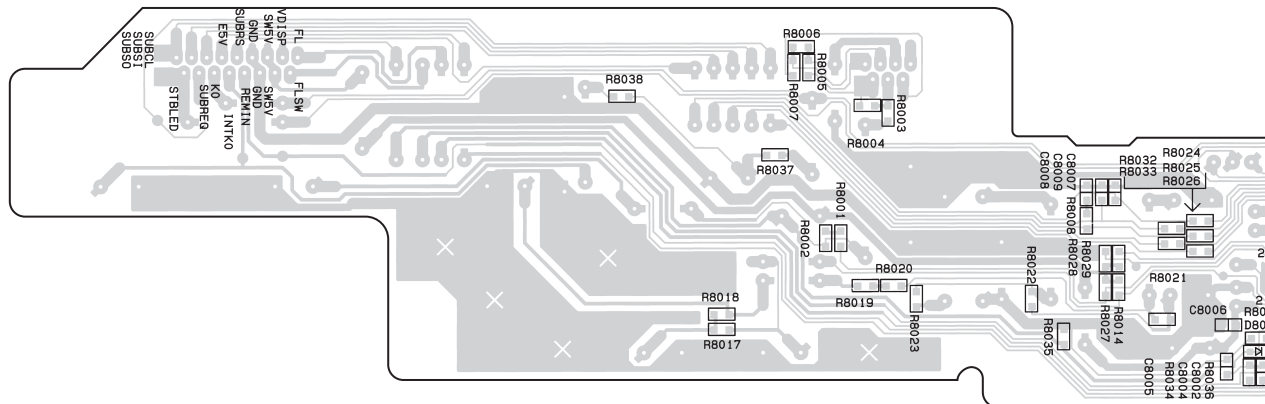

5

E

F

G

H

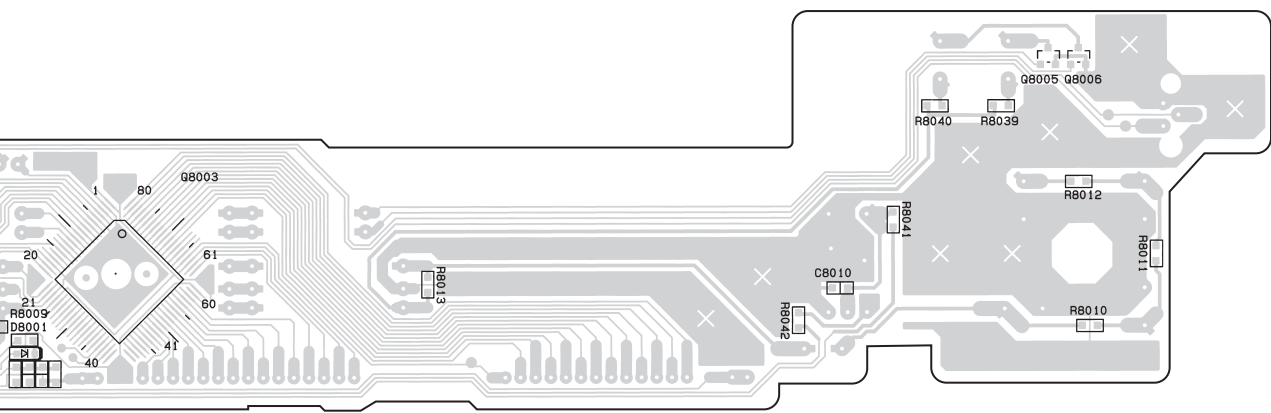
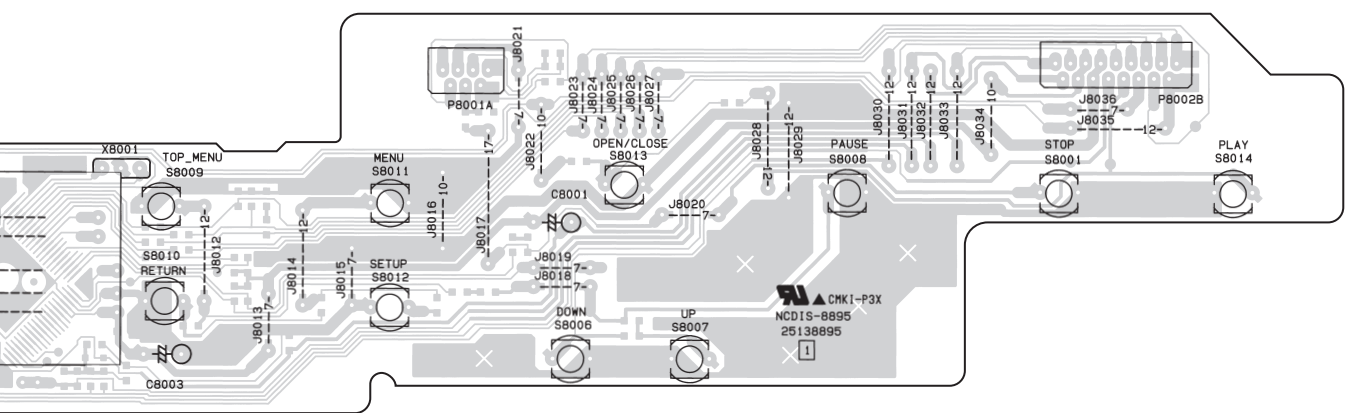

A

B

C

D

PRINTED CIRCUIT BOARD VIEWS-4

U03 Standby LED PC BOARD (NASW-8896)

Component side

Soldering side

1

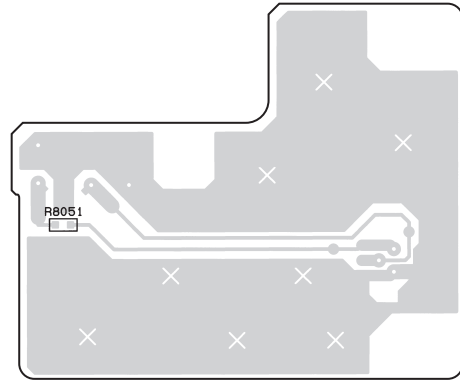
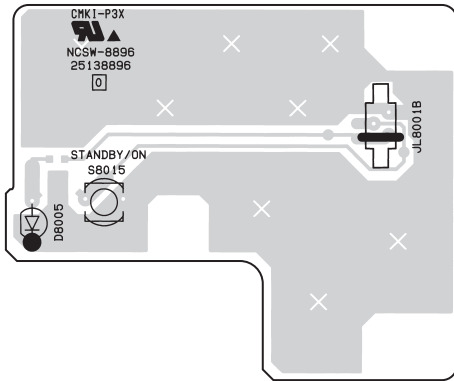

2

U04 Digital output terminal PC BOARD (NADG-8897)

Component side

Soldering side

3

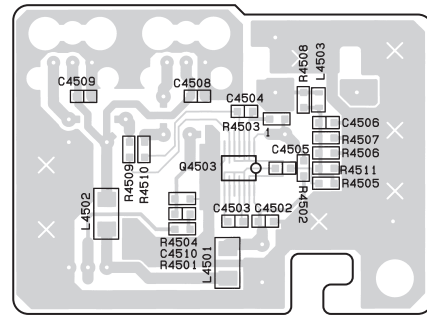
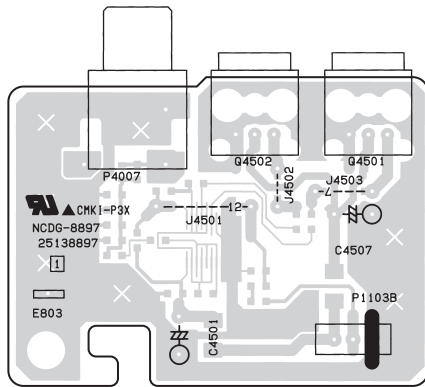

4

U05 RS-232C terminal PC BOARD (NADG-8899)

Component side

Soldering side

5

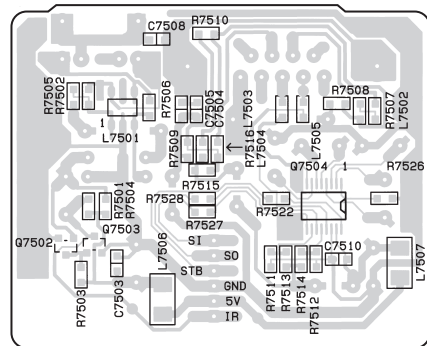
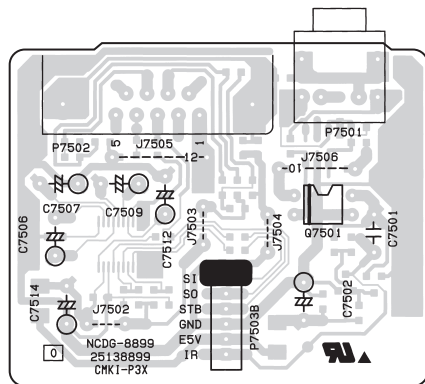

A

B

C

D

PRINTED CIRCUIT BOARD VIEWS-5

U06 Inlet terminal PC BOARD (NAPS-8900)

Component side

1

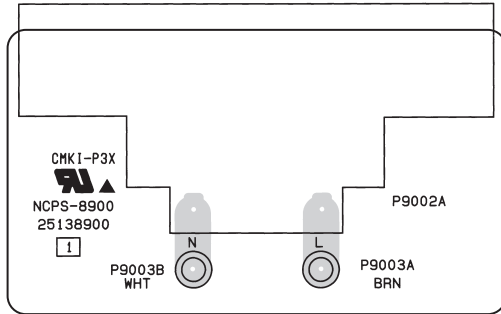

2

U07 AV Connector PC BOARD (NAVD-8901)

Component side

Soldering side

3

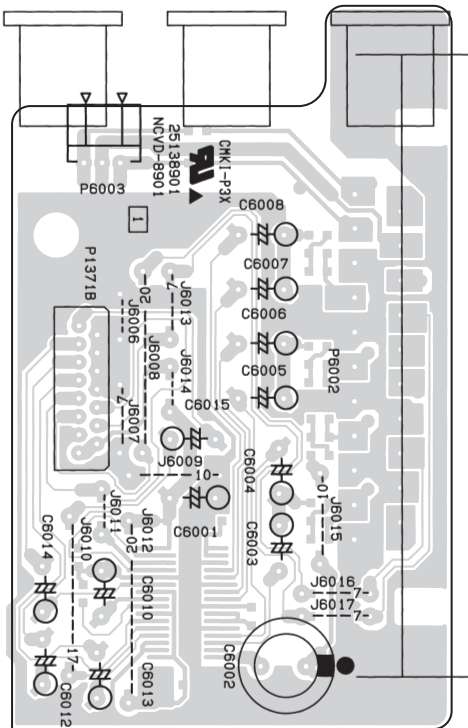

4

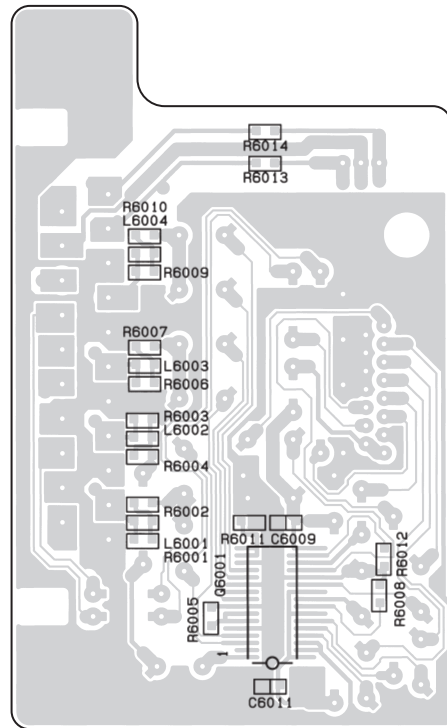

5

A

B

C

D

PRINTED CIRCUIT BOARD VIEWS-6

U10 DVD Main circuit PC BOARD (NADG-8905)

Side-A

1

2

3

4

5

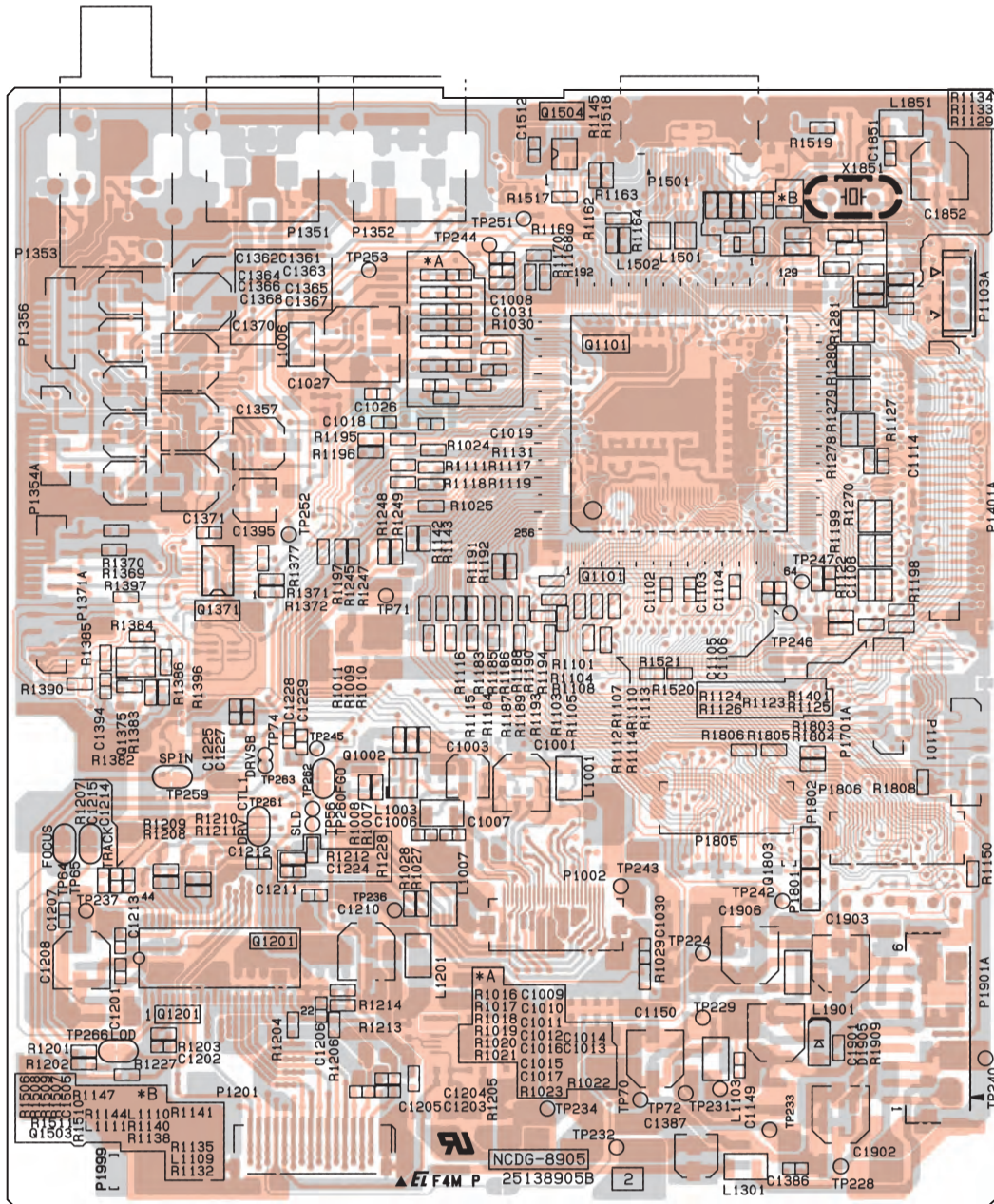

TEST MODE/ CONFIRM FW

1. Confirm Region code

- 1-1. Press "**Dimmer**" key and "**Pause**" key at the same time.
- 1-2. Press "**Pause**" key. Display "Region Code " on the FL tube.

MDD1N : USA 1 NTSC	MUP2P : EURO 2 PAL
MJJ2N : JPN 2 NTSC	MUT3P : ASIA 3 PAL
MUK3N : ASIA 3 NTSC	MUA4P : AUS 4 PAL

2. Test Mode

- 2-1. Press "**Stop**" key and "**Display**" key at the same time with NO DISC condition.
- 2-2. Display "SYS 06830A" on the FL tube.
(Version number of System MICIN)
- 2-3. Press "**Display**" key three (3) times.
- 2-3. Display "0E-060907A" on the FL tube.
(Version number of Back end MICIN)

TV MONITOR

Release Version : OE 060702A (HP-1-----)	H: Writing of HDCP key OK P: Writing of CPPM key OK 1: Region number
FE Version : 10.26	
BE Version : 1508530000	

- 2-4. Press "**Display**" key two (2) timesight up all segment of FL tube.
- 2-5. Press "**Standby**" bottom to exit the test mode.

3. Initializing

- 3-1. Press "**Stop**" key and "**Standby**" key at same time with No DISC condition.
Display "**INITIALIZE**" on the FL tube.
- 3-2. And display "COMPLETE" to "**STANDBY**".

SETTING FW

NOTE: This work does before TEST MODE
Prepared Special remote controller (RC-484M)

1. Setting firmware

1-1. Turn on power switch and display "No Disc" on the FL tube.

1-2. Press "DVD" key and "2" key at the same time.

1-3. Press "RETURN" key.

Display "REGION MODE" on the FL tube.

1-4. Press figure key (Example: 1=U.S.A.), and display "REGION01" on the FL tube.

MDD1N: "1" MUK3N: "3"

MUP2P: "2" MUA4P: "4"

MUT3P: "3"

2. How to FW rewrite

2-1. The following FW file and file with about 40M (WAVW or MP3 etc) are written.

2-2. Write it Disc at Once.

2-3. DISC that has already been written is put on tray and close the tray.

2-4. Disc is loaded, display is "Firmware Upgrade Erase and program start cancel" on the TV monitor.

2-5. Select "Start" and press "ENTER" key. Starting upload.

2-6. When the tray opens, DISC is taken out.

NOTE: Do not pull out the AC cord.
Initialize it after changing of writing.

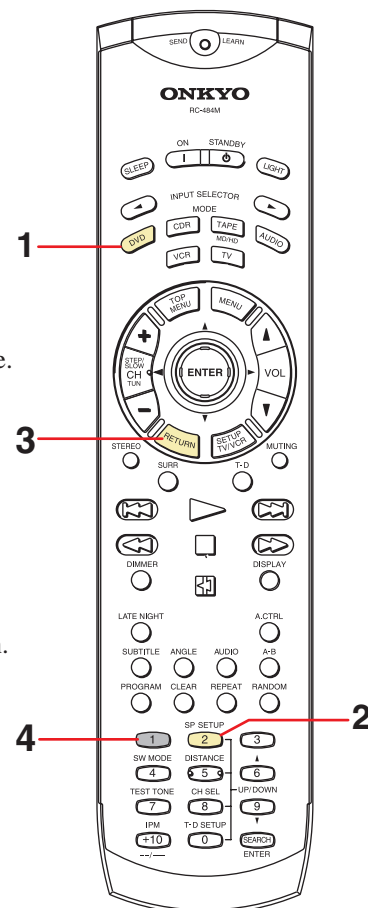

RC-484M
Part No. 24140484

NOTE: THE COMPONENTS IDENTIFIED BY MARK ! ARE CRITICAL FOR RISK OF FIRE AND ELECTRIC SHO REPLACE ONLY WITH PART NUMBER SPECIFIED.

: Black color

<S>: Silver color

<G>: Golden color

MDD1N: North American area

MUA4P: Australian area

MUT3P: East Asian area

MUK3N: Korean area

MUP2P: European area

EXPLODED VIEW PARTS LIST

REF. NO.	PART NAME	DESCRIPTION	PART NO.	REMARKS	
A001	CHASSIS	DV-SP504	27100480		1
A003	BOTTOM LEG	DV-SP504	27175433		4
A005	CUSHION	--	28141664		4
A007	SCREW	3TTB+8B(3CM)SR	801637		4
A008	IB CUSHION	W15*3t TAPE	28141585		2
A010	GUIDE	(MECHA)DV-SP504	27268183		1
A012	HOLDER	KGLS-12RT	27190266		10
A013	SCREW	3TTP+10P(3CM)	833130100GR		2
A014	SCREW	3P+10FN(3BC)	82143010GR		2
A015	CLAMP	HL-18-0	27301394		1
A017	SCREW	4TTC+8C(3BC)	830440089GR		1
A018	TAPE	TAPE(CLOTH-8U)	29110082		3
A019	IB CUSHION	W15*3t TAPE	28141585		2
A020	LABEL	(DVD3)	29364728		1
A022	TAPE	TAPE(CLOTH-8U)	29110082		1
A025	F BRACKET	(AS)	27111363A		1
A025	F BRACKET	(AS)	27111365A	<G>	1
A025	F BRACKET	(AS)(S)	27111414A	<S>	1
A028	CLEAR PLT	DV-SP502(B)	28192043		1
A028	CLEAR PLT	DV-SP502(G)	28192044	<G> <S>	1
A030	SCREW	3TTB+8B(3CM)SR	801637		10
A033	SCREW	2.6TTB+8B(3BC)	838426088GR		3
A034	CUSHION	--	28141606		2
A040	KNOB	(CRS)	28326244		1
A040	KNOB	(CRS)	28326245	<G> <S>	1
A051	DOOR	DV-SP504(B)	28148645		1
A051	DOOR	DV-SP504(G)	28148647	<G>	1
A051	DOOR	DV-SP504(S)	28148646	<S>	1
A055	COVER	(B)	28184864		1
A055	COVER	(G)	28184866	<G>	1
A055	COVER	503(S)	28184934	<S>	1
A056	SCREW	3TTB+8B(3BC)	838430088GR		6
A056	SCREW	3TTB+8B(3CM)	838130088GR	<G>	6
A056	SCREW	3TTB+8B(3CM)	838130088GR	<S>	6
A401	F PANEL	504(B)MDD	27212924	 N	1
A401	F PANEL	DV-SP504(B)MUA	27212944	 MUA4P, N	1
A401	F PANEL	504(N)MJJ	27212923	<G> MUT3P MUK3N, N	1
A401	F PANEL	504(S)MDD	27212928	<S> MDD1N, N	1
A401	F PANEL	DV-SP504(S)MUA	27212945	<S> MUA4P, N	1
A401	F PANEL	504E(B)	27212925	 504EMUP2P, N	1
A401	F PANEL	504E(S)	27212926	<S> 504EMUP2P, N	1

A403	BADGE	BADGE	28135244		1
A403	BADGE	BADGE	28135245	<G>	2/18 PAGE
A403	BADGE	--	28135298	<S>	1
A404	FACET	(S)	28198906		2
A406	SCREW	3TTB+8B(3BC)	838430088GR		3
A411	REAR PANEL	DVSP504MDD	27123576A	 MDD1N, N	1
A411	REAR PANEL	DVSP504MUA	27123577A	 MUA4P, N	1
A411	REAR PANEL	DVSP504MUA	27123577A	<S> MUA4P, N	1
A411	REAR PANEL	DVSP504MUT/UK	27123579A	<G> MUT3P	1
A411	REAR PANEL	DVSP504MUT/UK	27123579A	<G> MUK3N, N	1
A411	REAR PANEL	DVSP504MDD	27123576A	<S> MDD1N, N	1
A411	REAR PANEL	DVSP504EMUP	27123575A	 504EMUP2P, N	1
A411	REAR PANEL	DVSP504EMUP	27123575A	<S> 504EMUP2P, N	1
A412	LABEL	(WEEE)	29364199	504E	1
A413	SCREW	3TTB+8B(3BC)	838430088GR	MDD1N	16
A413	SCREW	3TTB+8B(3BC)	838430088GR	MUP2P	17
A413	SCREW	3TTB+8B(3BC)	838430088GR	MUA4P,MUT3P,	15
A413	SCREW	3TTB+8B(3BC)	838430088GR	MUK3N	15
A414	GUIDE	(CD)DV-SP504	27268184		1
A414	GUIDE	(CD)DV-SP504(G)	27268187	<G>	1
A414	GUIDE	(CD)DV-SP504(S)	27268186	<S>	1
A415	TAPE	TAPE(CLOTH-8U)	29110082		1
A416	SCREW	4TTB+8C(3BC)	838440089GR		2
A417	CUSHION	UC-300279TKITAGAWA	28141705	<MDD1N> only, N	1
P901A	CORE	NFY-25 BLACK	230945		1
P910	WIRE TIE	BSK-1	260208		2
P911	WIRE TIE	BINDER(CLAMPER)U L	260258		1
Q1101A	HEAT SINK	HH-AA-D-P	27160598		1
S731	JOY STICK	NPS-115-S673	25035710		1
U01	Output terminal PC board assy	NAAR-8894-1A	1H539594-1A	<MDD1N> N	1
U01	Output terminal PC board assy	NAAR-8894-1B	1H539594-1B	<MUA4P> N	1
U01	Output terminal PC board assy	NAAR-8894-1D	1H539594-1D	<MUT3P> N	1
U01	Output terminal PC board assy	NAAR-8894-1E	1H539594-1E	504E <MPP2P> N	1
U01	Output terminal PC board assy	NAAR-8894-1J	1H539594-1J	<MUK3N> N	1
U02	Display circuit PC board assy	NADIS-8895-1A	1H539595-1A	<MDD1N> N	1
U02	Display circuit PC board assy	NADIS-8895-1B	1H539595-1B	<MUA4P> N	1
U02	Display circuit PC board assy	NADIS-8895-1D	1H539595-1D	<MUT3P> N	1
U02	Display circuit PC board assy	NADIS-8895-1E	1H539595-1E	504E <MPP2P> N	1
U02	Display circuit PC board assy	NADIS-8895-1J	1H539595-1J	<MUK3N> N	1
U03	Standby LED PC board assy	NASW-8896-1A	1H539596-1A	<MDD1N> N	1
U03	Standby LED PC board assy	NASW-8896-1B	1H539596-1B	<MUA4P> N	1
U03	Standby LED PC board assy	NASW-8896-1D	1H539596-1D	<MUT3P> N	1
U03	Standby LED PC board assy	NASW-8896-1E	1H539596-1E	504E <MPP2P> N	1
U03	Standby LED PC board assy	NASW-8896-1J	1H539596-1J	<MUK3N> N	1
U04	Digital output terminal PC board assy	NADG-8897-1A	1H539597-1A	<MDD1N> N	1
U04	Digital output terminal PC board assy	NADG-8897-1B	1H539597-1B	<MUA4P> N	1
U04	Digital output terminal PC board assy	NADG-8897-1D	1H539597-1D	<MUT3P> N	1
U04	Digital output terminal PC board assy	NADG-8897-1E	1H539597-1E	504E <MPP2P> N	1
U04	Digital output terminal PC board assy	NADG-8897-1J	1H539597-1J	<MUK3N> N	1
U05	RS-232C terminal PC board assy	NADG-8899-1A	1H539599-1A	<MDD1N> only N	1
U06	Inlet terminal PC board assy	NAPS-8900-1A	1H539500-1A	<MDD1N> N	1
U06	Inlet terminal PC board assy	NAPS-8900-1B	1H539500-1B	<MUA4P> N	1
U06	Inlet terminal PC board assy	NAPS-8900-1D	1H539500-1D	<MUT3P> N	1
U06	Inlet terminal PC board assy	NAPS-8900-1E	1H539500-1E	504E <MPP2P> N	1
U06	Inlet terminal PC board assy	NAPS-8900-1J	1H539500-1J	<MUK3N> N	1

U07	AV Connector PC board assy	NAVD-8901-1E	1H539501-1E	504E <MPP2P> only N	1
U10	DVD Main circuit PC board assy	NADG-8905-1A	1H539505-1A	Except MPP2P, N	18 PAGE
U10	DVD Main circuit PC board assy	NADG-8905-1E	1H539505-1E	MPP2P only, N	1
U11	Power supply unit	NGPS-0074-100-120V	24150074A	MDD1N	1
U11	Power supply unit	NGPS-0075-100-240V	24150075	<MUA4P> N	1
U11	Power supply unit	NGPS-0075-100-240V	24150075	<MUT3P> N	1
U11	Power supply unit	NGPS-0075-100-240V	24150075	<MUK3N> N	1
U11	Power supply unit	NGPS-0075-100-240V	24150075	504E <MPP2P> N	1
Z101	DVD Mechanism assy	TD-505SF	24801031	N	1
Z102	HOLDER	(M)DV-SP504	27191277		2
Z103	SCREW	2TTB+8B(3CM)	838120088GR		2
Z104	SCREW	2.6TTB+8B(3BC)	838426088GR		4
Z105	SCREW	3TTB+8B(3BC)	838430088GR		4
Z106	IB CUSHION	W15*3t TAPE	28141585		1
Z108	WASHER	W3*8F(3CM)	87613008GR		4
Z109	DF TAPE	W3	29110029		4
F101	FUSE	2A-UL/T-233	252320GR	! <MDD1N>	1
F101	FUSE	2A-SE-EAK FUSE	252074GR	! <MUA4P>	1
F101	FUSE	2A-SE-EAK FUSE	252074GR	! <MUT3P>	1
F101	FUSE	2A-SE-EAK FUSE	252074GR	! <MUK3N>	1
F101	FUSE	2A-SE-EAK FUSE	252074GR	! 504E <MPP2P>	1
P1001	FFC	NC FCC-242512	204C242512A	N	1
P1371	FFC	NCFC5-151012	2045151012	504E <MPP2P> only, N	1
P1401	FFC	NCFC5-290522	2045290522		1
P1701	FFC	NCFC5-100512	2045100512		1
P1901	SOCKET AS	NSAS-18P1645	20044191815UL		1
P8002	FFC	NCFC5-171222	2045171222		1
F102	Fuse	MQ2A/125V	OP66	! Quick Acting Micro fuse	1
F105	Fuse	MQ3A/125V	OP67	! Quick Acting Micro fuse	1

PACKING VIEW PARTS LIST

				DV-SP504	
REF. NO.	PART NAME	DESCRIPTION	PART NO.	REMARKS	
A450	CARTON	DV-SP504(B)	29054531A	<B MDD1N> N	1
A450	CARTON	DV-SP504(B)MUA	29054590A	<B MUA4P> N	1
A450	CARTON	DV-SP504(G)	29054533A	<G MUT3P>, N	1
A450	CARTON	DV-SP504(G)	29054533A	<G MUK3N>, N	1
A450	CARTON	DV-SP504(S)	29054532A	<S MDD> N	1
A450	CARTON	DV-SP504(S)MUA	29054591A	<S MUA4P> N	1
A450	CARTON	DV-SP504E(B)	29054534A	504E <B MUP2P>, N	1
A450	CARTON	DV-SP504E(S)	29054535A	504E <S MUP2P>, N	1
A451	LABEL	(RE)MUT3P	29363448A	MUT3P only	2
A451	LABEL	MUK3N	29364489	MUK3N only	2
A455	UPC LABEL	DV-SP504(B)MDD	29364475	<B MDD1N> N	1
A455	EAN LABEL	DV-SP504(B)MUA	29364472	<B MUA4P> N	1
A455	EAN LABEL	DV-SP504(G)	29364474	<G MUT3P> N	1
A455	EAN LABEL	DV-SP504(G)	29364474	<G MUK3N>, N	1
A455	UPC LABEL	DV-SP504(S)MDD	29364476	<S MDD1N> N	1
A455	EAN LABEL	DV-SP504(S)MUA	29364473	<S MUA4P> N	1
A455	EAN LABEL	DV-SP504E(B)MUP	29364470	504E <B MUP2P> N	1
A455	EAN LABEL	DV-SP504E(S)MUP	29364471	504E <S MUP2P> N	1
A530	WRNTY CARD	(ONKYO)	29365102A	MDD1N only	1
A601	PAD	(AS)DV-SP504	29092321		1

A604	POLY BAG	650*500	29100037-1A	For unit	1
A605	POLY BAG	350*250	29100097-1A	For instruction manual	1
A606	TAPE	NITTO NO.29	29110149		1
A607	PP TAPE	W48 OPP TAPE	29110148		1
A833	POLY BAG	350*250	29100097-1A	504E MPP2P only	1
A834	TAPE	NITTO NO.29	29110149	504E MPP2P only	1
A835	PAD	TOP	29092108B	504E MPP2P only	1
A901	PIN CORD AS	RCA3P(YWR)	2010379		1
A902	BATTERY	R6/AA(UM-3)	3010194		2
A902 or	BATTERY	R6/AA(UM-3)	3010054		(2)
A903	PLUG CORD	3.5-MINI PLUG (RI)	2010200		1
A904	CORD AS	RCA-1P(O)	2010424		1
A905	REMO CON	RC-657DV	24140657	N	1
A906	INS MANUAL	U8(DVSP504)	29344325		1
A910	INS MANUAL	En(DV-SP504)	29344210	N	1
A911	INS MANUAL	Ct(DV-SP504)	29344213	<MUT3P> N	1
A911	INS MANUAL	U2FrEs(DV-SP504)	29344211	504E <MPP2P> N	1
A912	INS MANUAL	U2ItDe(DVSP504)	29344354	504E <MPP2P> N	1
A913	INS MANUAL	U2NISv(DVSP504)	29344355	504E <MPP2P> N	1
P9002	AC CORD	AS-UC-2	253352TES	! <MDD1N>	1
P9002 or	AC CORD	AS-UC-2	253297KAW	! <MDD1N>	(1)
P9002	AC CORD	AS-SAA	253391VOL	! <MUA4P>	1
P9002	AC CORD	AS-CEE-3	253298KAW	! <MUT3P>	1
P9002	AC CORD	AS-CEE-3	253298KAW	! <MUK3N>	1
P9002	AC CORD	AS-CEE-3	253298KAW	! 504E <MPP2P>	1
P9003	CV PLUG	CV-K-1	25056005	! <MUT3P>	1

PRINTED CIRCUIT BOARD PARTS LIST

DV-SP504

U01	Output terminal PC board assy	NAAK-0094-1A	<MDD1N> N
U01	Output terminal PC board assy	NAAK-0094-1B	<MUA4P> N
U01	Output terminal PC board assy	NAAK-0094-1D	<MUT3P> N
U01	Output terminal PC board assy	NAAK-0094-1E	504E <MPP2P> N
U01	Output terminal PC board assy	NAAK-0094-1I	<MUK3N> N
U02	Display circuit PC board assy	NADIS-0093-1A	<MDD1N> N
U02	Display circuit PC board assy	NADIS-0093-1B	<MUA4P> N
U02	Display circuit PC board assy	NADIS-0093-1D	<MUT3P> N
U02	Display circuit PC board assy	NADIS-0093-1E	504E <MPP2P> N
U02	Display circuit PC board assy	NADIS-0093-1I	<MUK3N> N
U03	Standby LED PC board assy	NADV-0090-1A	<MDD1N> N
U03	Standby LED PC board assy	NADV-0090-1B	<MUA4P> N
U03	Standby LED PC board assy	NADV-0090-1D	<MUT3P> N
U03	Standby LED PC board assy	NADV-0090-1E	504E <MPP2P> N
U03	Standby LED PC board assy	NADV-0090-1I	<MUK3N> N
U04	Digital output terminal PC board assy	NADG-0091-1A	<MDD1N> N
U04	Digital output terminal PC board assy	NADG-0091-1B	<MUA4P> N
U04	Digital output terminal PC board assy	NADG-0091-1D	<MUT3P> N
U04	Digital output terminal PC board assy	NADG-0091-1E	504E <MPP2P> N
U04	Digital output terminal PC board assy	NADG-0091-1A	<MUK3N> N
U05	RS-232C terminal PC board assy	NADG-0099-1A	<MDD1N> only N
U06	Inlet terminal PC board assy	NAF3-0900-1A	<MDD1N> N
U06	Inlet terminal PC board assy	NAF3-0900-1B	<MUA4P> N
U06	Inlet terminal PC board assy	NAF3-0900-1D	<MUT3P> N

U06	Inlet terminal PC board assy
U06	Inlet terminal PC board assy
U07	AV Connector PC board assy

NAVS-8900-1E 504E <MPP2P> N
NAVS-8900-1J <MUK3N> N 5/18 PAGE
NAVD-8901-1E 504E <MPP2P> only N

CIRCUIT

	NO.	PART NAME	DESCRIPTION	PART NO.	REMARKS	Q'ty
AR8894	C4001	VX C	CE04W10V- 220M(VX_RLK)	397332217		1
AR8894	C4002	TF C	ECQ-V50V-104J	374721044		1
AR8894	C4003	RFS C	CE04W25V-47M(RFS)	395954707		1
AR8894	C4004	TF C	ECQ-V50V-104J	374721044		1
AR8894	C4005	VX C	CE04W50V- 100M(VX_RLK)	397381017		1
AR8894	C4006	TF C	ECQ-V50V-104J	374721044		1
AR8894	C4007	VX C	CE04W50V- 17M(VX_RLK)	397380477		1
AR8894	C4021	VX C	CE04W10V- 220M(VX_RLK)	397332217		1
AR8894	C4022	TF C	ECQ-V50V-104J	374721044		1
AR8894	C4023	VX C	CE04W6.3V- 170M(VX_RLK)	397324717		1
AR8894	C4024	TF C	ECQ-V50V-104J	374721044		1
AR8894	C4025	VX C	CE04W50V- 100M(VX_RLK)	397381017		1
AR8894	C4026	TF C	ECQ-V50V-104J	374721044		1
AR8894	C4027	VX C	CE04W50V- 17M(VX_RLK)	397380477		1
AR8894	C4041	VX C	CE04W10V- 220M(VX_RLK)	397332217		1
AR8894	C4042	TF C	ECQ-V50V-104J	374721044		1
AR8894	C4043	VX C	CE04W6.3V- 170M(VX_RLK)	397324717		1
AR8894	C4044	TF C	ECQ-V50V-104J	374721044		1
AR8894	C4045	VX C	CE04W50V- 100M(VX_RLK)	397381017		1
AR8894	C4046	TF C	ECQ-V50V-104J	374721044		1
AR8894	C4047	VX C	CE04W50V- 17M(VX_RLK)	397380477		1
AR8894	C4061	C-CERA C	CK725B1H-103K1	332101035R1		1
AR8894	C4062	C-CERA C	CK725F1H-104Z1	332151040R1		1
AR8894	C4101	TF C	ECQ-B50V-331K	374723315		1
AR8894	C4102	TF C	ECQ-B50V-331K	374723315		1
AR8894	C4103	TF C	ECQ-B50V-331K	374723315		1
AR8894	C4104	TF C	ECQ-B50V-331K	374723315		1
AR8894	C4107	TF C	ECQ-B50V-152J	374721524		1
AR8894	C4108	TF C	ECQ-B50V-152J	374721524		1
AR8894	C4109	TF C	ECQ-B50V-561J	374725614		1
AR8894	C4110	TF C	ECQ-B50V-561J	374725614		1
AR8894	C4111	RFS C	CE04W50V-47M(RFS)	395984707		1
AR8894	C4112	RFS C	CE04W50V-47M(RFS)	395984707		1
AR8894	C4115	VX C	CE04W16V- 170M(VX_RLK)	397344717		1
AR8894	C4116	VX C	CE04W16V- 170M(VX_RLK)	397344717		1
AR8894	C4201	TF C	ECQ-B50V-331K	374723315		1
AR8894	C4202	TF C	ECQ-B50V-331K	374723315		1
AR8894	C4203	TF C	ECQ-B50V-331K	374723315		1
AR8894	C4204	TF C	ECQ-B50V-331K	374723315		1
AR8894	C4207	TF C	ECQ-B50V-152J	374721524		1
AR8894	C4208	TF C	ECQ-B50V-152J	374721524		1
AR8894	C4209	TF C	ECQ-B50V-561J	374725614		1
AR8894	C4210	TF C	ECQ-B50V-561J	374725614		1
AR8894	C4211	VX C	CE04W25V- 17M(VX_RLK)	397354707		1
AR8894	C4212	VX C	CE04W25V- 17M(VX_RLK)	397354707		1
AR8894	C4215	VX C	CE04W16V- 170M(VX_RLK)	397344717		1
AR8894	C4216	VX C	CE04W16V- 170M(VX_RLK)	397344717		1
AR8894	C4219	VX C	CE04W25V- 17M(VX_RLK)	397354707		1
AR8894	C4220	VX C	CE04W25V- 17M(VX_RLK)	397354707		1
AR8894	C4221	VX C	CE04W25V- 17M(VX_RLK)	397354707		1

AR8894	C4222	VX C	CE04W25V- 17M(VX_RLK)	397354707		1
AR8894	C4301	TF C	ECQ-B50V-331K	374723315		6/18 PAGE
AR8894	C4302	TF C	ECQ-B50V-331K	374723315		1
AR8894	C4303	TF C	ECQ-B50V-331K	374723315		1
AR8894	C4304	TF C	ECQ-B50V-331K	374723315		1
AR8894	C4307	TF C	ECQ-B50V-152J	374721524		1
AR8894	C4308	TF C	ECQ-B50V-152J	374721524		1
AR8894	C4309	TF C	ECQ-B50V-561J	374725614		1
AR8894	C4310	TF C	ECQ-B50V-561J	374725614		1
AR8894	C4311	VX C	CE04W25V- 17M(VX_RLK)	397354707		1
AR8894	C4312	VX C	CE04W25V- 17M(VX_RLK)	397354707		1
AR8894	C4315	VX C	CE04W16V- 170M(VX_RLK)	397344717		1
AR8894	C4316	VX C	CE04W16V- 170M(VX_RLK)	397344717		1
AR8894	C4501	VX C	CE04W10V- 220M(VX_RLK)	397332217		1
AR8894	C4502	C-CERA C	CK725F1H-104Z1	332151040R1		1
AR8894	C4505	C-CERA C	CK725B1C-104K1	332121045R1		1
AR8894	C4506	C-CERA C	CC725CH1H-220J1	342102204R1		1
AR8894	C4507	VX C	CE04W10V- 220M(VX_RLK)	397332217		1
AR8894	C4508	C-CERA C	CK725F1H-104Z1	332151040R1		1
AR8894	C4510	C-CERA C	CK725B1C-104K1	332121045R1		1
AR8894	C6001	VX C	CE04W30V- 22M(VX_RLK)	397382207	MPP2P only	1
AR8894	C6002	VX C	CE04W6.3V- 1000M(VX_RLK)	397321027	MPP2P only, N	1
AR8894	C6003	VX C	CE04W30V- 100M(VX_RLK)	397321017	MPP2P only	1
AR8894	C6004	VX C	CE04W30V- 22M(VX_RLK)	397382207	MPP2P only	1
AR8894	C6005	VX C	CE04W6.3V- 100M(VX_RLK)	397321017	MPP2P only	1
AR8894	C6006	VX C	CE04W30V- 22M(VX_RLK)	397382207	MPP2P only	1
AR8894	C6007	VX C	CE04W6.3V- 100M(VX_RLK)	397321017	MPP2P only	1
AR8894	C6008	VX C	CE04W30V- 22M(VX_RLK)	397382207	MPP2P only	1
AR8894	C6009	C-CERA C	CK725F1A-105Z1	332181050R1	MPP2P only	1
AR8894	C6010	VX C	CE04W30V- 22M(VX_RLK)	397382207	MPP2P only	1
AR8894	C6011	C-CERA C	CK725F1A-105Z1	332181050R1	MPP2P only	1
AR8894	C6012	VX C	CE04W30V- 1M(VX_RLK)	397380107	MPP2P only, N	1
AR8894	C6013	VX C	CE04W30V- 1M(VX_RLK)	397380107	MPP2P only, N	1
AR8894	C6014	VX C	CE04W30V- 1M(VX_RLK)	397380107	MPP2P only, N	1
AR8894	C6015	VX C	CE04W30V- 1M(VX_RLK)	397380107	MPP2P only, N	1
AR8894	C7001	C-CERA C	CK725F1H-104Z1	332151040R1		1
AR8894	C7002	C-CERA C	CK725F1H-104Z1	332151040R1		1
AR8894	C7003	VX C	CE04W10V- 220M(VX_RLK)	397332217		1
AR8894	C7004	VX C	CE04W10V- 220M(VX_RLK)	397332217		1
AR8894	C7005	C-CERA C	CK725F1H-104Z1	332151040R1		1
AR8894	C7006	VX C	CE04W10V- 220M(VX_RLK)	397332217		1
AR8894	C7007	C-CERA C	CK725F1H-104Z1	332151040R1		1
AR8894	C7008	VR C	CE04W16V-4700M(VR)	394644727S		1
AR8894	C7010	PW C	CE04W16V-470M(PW)	393744717		1
AR8894	C7011	VX C	CE04W10V- 220M(VX_RLK)	397332217		1
AR8894	C7012	C-CERA C	CK725F1H-104Z1	332151040R1		1
AR8894	C7013	C-CERA C	CK725F1H-104Z1	332151040R1		1
AR8894	C7017	VX C	CE04W16V- 2200M(VX_RLK)	397342227S		1
AR8894	C7018	VX C	CE04W16V- 2200M(VX_RLK)	397342227S		1
AR8894	C7024	C-CERA C	CK725F1H-104Z1	332151040R1		1
AR8894	C7025	C-CERA C	CK725F1H-104Z1	332151040R1		1
AR8894	C7501	TF C	ECQ-V50V-683J	374726834	MDD1N	1
AR8894	C7502	VX C	CE04W10V- 100M(VX_RLK)	397331017	MDD1N, N	1
AR8894	C7503	C-CERA C	CK725F1H-104Z1	332151040R1	MDD1N	1
AR8894	C7504	C-CERA C	CK725F1H-104Z1	332151040R1	MDD1N	1
AR8894	C7505	C-CERA C	CK725F1H-104Z1	332151040R1	MDD1N	1

AR8894	C7506	VX C	CE04W50V-0.47M(VX_RLK)	397384797	MDD1N, N	1
AR8894	C7507	VX C	CE04W50V-0.17M(VX_RLK)	397384797	MDD1N, N	7/18 PAGE
AR8894	C7508	C-CERA C	CK725F1H-104Z1	332151040R1	MDD1N	1
AR8894	C7509	VX C	CE04W50V-0.47M(VX_RLK)	397384797	MDD1N, N	1
AR8894	C7510	C-CERA C	CK725F1H-104Z1	332151040R1	MDD1N	1
AR8894	C7512	VX C	CE04W50V-0.47M(VX_RLK)	397384797	MDD1N, N	1
AR8894	C7514	VX C	CE04W10V-100M(VX_RLK)	397331017	MDD1N, N	1
AR8894	C8001	ELECT C	CE04W50V-22M	355782209		1
AR8894	C8002	C-CERA C	CK725F1H-104Z1	332151040R1		1
AR8894	C8003	ELECT C	CE04W6.3V-100M	355721019		1
AR8894	C8004	C-CERA C	CK725F1H-104Z1	332151040R1		1
AR8894	C8005	C-CERA C	CK725F1H-223Z1	332152230R1		1
AR8894	C8006	C-CERA C	CK725F1H-104Z1	332151040R1		1
AR8894	C8007	C-CERA C	CC725CH1H-220J1	342102204R1		1
AR8894	C8008	C-CERA C	CC725CH1H-220J1	342102204R1		1
AR8894	C8009	C-CERA C	CC725CH1H-220J1	342102204R1		1
AR8894	C8010	C-CERA C	CK725F1H-104Z1	332151040R1		1
AR8894	C8011	ELECT C	CE04W6.3V-100M	355721019		1
AR8894	D4101	C-DIODE	1SS352	223234R2		1
AR8894	D4101 or	C-DIODE	1SS355	223269R2		(1)
AR8894	D4102	C-DIODE	1SS352	223234R2		1
AR8894	D4102 or	C-DIODE	1SS355	223269R2		(1)
AR8894	D4201	C-DIODE	1SS352	223234R2		1
AR8894	D4201 or	C-DIODE	1SS355	223269R2		(1)
AR8894	D4202	C-DIODE	1SS352	223234R2		1
AR8894	D4202 or	C-DIODE	1SS355	223269R2		(1)
AR8894	D4203	C-DIODE	1SS352	223234R2		1
AR8894	D4203 or	C-DIODE	1SS355	223269R2		(1)
AR8894	D4204	C-DIODE	1SS352	223234R2		1
AR8894	D4204 or	C-DIODE	1SS355	223269R2		(1)
AR8894	D4205	C-DIODE	1SS352	223234R2		1
AR8894	D4205 or	C-DIODE	1SS355	223269R2		(1)
AR8894	D4301	C-DIODE	1SS352	223234R2		1
AR8894	D4301 or	C-DIODE	1SS355	223269R2		(1)
AR8894	D4302	C-DIODE	1SS352	223234R2		1
AR8894	D4302 or	C-DIODE	1SS355	223269R2		(1)
AR8894	D7001	C-DIODE	1SS352	223234R2		1
AR8894	D7001 or	C-DIODE	1SS355	223269R2		(1)
AR8894	D7002	ZENER D	UDZS5.6B	224550560R2		1
AR8894	D7003	DIODE	GP104003E	22380035		1
AR8894	D7003 or	DIODE	RL1N4003	22380260		(1)
AR8894	D7004	C-DIODE	1SS352	223234R2		1
AR8894	D7004 or	C-DIODE	1SS355	223269R2		(1)
AR8894	D7005	C-DIODE	1SS352	223234R2		1
AR8894	D7005 or	C-DIODE	1SS355	223269R2		(1)
AR8894	D8001	ZENER D	UDZS5.6B	224550560R2		1
AR8894	D8002	LED	SEL2910A-TP6	225390		1
AR8894	D8005	LED	SLI-343URC-TB7	225452		1
AR8894	E801	CLAMP	WS-2NS	27300833		1
AR8894	E802	CLAMP	HL-28-0	27301396		1
AR8894	JL8001A	WIRE HOL	NSCT-3P874	25051087		1
AR8894	JL8001B	WIRE HOL	NSCT-3P874	25051087		1
AR8894	L4501	CHOKE COIL	NCH-1471	231237M022R2		1
AR8894	L4502	CHOKE COIL	NCH-1471	231237M022R2		1
AR8894	L4503	CHOKE COIL	BLM21B222SPT	230921R2		1
AR8894	L7002	CHOKE COIL	BLM21B222SPT	230921R2		1

AR8894	L7003	CHOKE COIL	NCH-1475	231237K100R2		1
AR8894	L7004	CHOKE COIL	NCH-1475	231237K100R2		8/18 PAGE
AR8894	L7005	CHOKE COIL	NCH-1475	231237K100R2		1
AR8894	L7006	CHOKE COIL	NCH-1473	231237M047R2		1
AR8894	L7502	EMIFIL	BK1608LM182-T	230958R1		1
AR8894	L7503	EMIFIL	BK1608LM182-T	230958R1		1
AR8894	L7504	EMIFIL	BK1608LM182-T	230958R1		1
AR8894	L7505	EMIFIL	BK1608LM182-T	230958R1		1
AR8894	L7506	CHOKE COIL	NCH-1471	231237M022R2		1
AR8894	L7507	CHOKE COIL	NCH-1471	231237M022R2		1
AR8894	P1103B	SOCKET AS	NSAS-6P1607	2009991018UL	N	1
AR8894	P1371B	SOCKET	NSCT-15P2433	25052536	MPP2P	1
AR8894	P1371Bor	SOCKET	NSCT-15P2249	25052352	MPP2P	(1)
AR8894	P1401B	SOCKET	NSCT-29P2226	25052329		1
AR8894	P1701B	SOCKET	NSCT-10P2207	25052310		1
AR8894	P1901B	PLUG	NPLG-9P137	25055153		1
AR8894	P4001	PIN JACK	NPJ-2PDRW435	25045628		1
AR8894	P4002	PIN JACK	NPJ-6PDWRLECP508	25045717		1
AR8894	P4003	PIN JACK	NPJ-2PDNT644	25045868	N	1
AR8894	P4004	SOCKET AS	NSAS-6P1611	2009991019UL	N	1
AR8894	P4006	PIN JACK	NPJ-2PDB400	25045589		1
AR8894	P4007	PIN JACK	NPJ-1PDOR369	25045548		1
AR8894	P6002	SOCKET	YKF41-5050	25053036	MPP2P	1
AR8894	P6003	PLUG	NPLG-3P350	25055367	MPP2P	1
AR8894	P7501	ST JACK	HSJ1002-01-1020	25045647	MDD1N	1
AR8894	P7502	SOCKET	NSCT-9P2277	25052379	MDD1N	1
AR8894	P7502 or	SOCKET	7906-09FHA	25053103	MDD1N	(1)
AR8894	P7503A	PLUG	NPLG-6P134	25055150		1
AR8894	P7503B	SOCKET AS	NSAS-12P1627	2002A391235UL	MDD1N	1
AR8894	P8001A	SOCKET	NSCT-7P2241	25052344		1
AR8894	P8002A	SOCKET	NSCT-17P2214	25052317		1
AR8894	P8002B	SOCKET	NSCT-17P2251	25052354		1
AR8894	P9001	SOCKET AS	NSAS-30P1628	2004C193065UL		1
AR8894	P9002A	AC INLET	NPLG-2P913	25055960		1
AR8894	P9003	SOCKET AS	NSAS-4P1629	2009991035UL		1
AR8894	Q1706	IC	TC7SZ125FU(TE85L_F)	22241895R2		1
AR8894	Q1707	IC	TC7SZ125FU(TE85L_F)	22241895R2		1
AR8894	Q4001	IC	CS4398-CZZ(R)	22242227R2		1
AR8894	Q4002	IC	MPC29M33HF	22278033ENE		1
AR8894	Q4003	IC	78M05HF(MPC/78M05HF)	222780055NEC		1
AR8894	Q4021	IC	CS4398-CZZ(R)	22242227R2		1
AR8894	Q4022	IC	MPC29M33HF	22278033ENE		1
AR8894	Q4023	IC	78M05HF(MPC/78M05HF)	222780055NEC		1
AR8894	Q4041	IC	CS4398-CZZ(R)	22242227R2		1
AR8894	Q4042	IC	MPC29M33HF	22278033ENE		1
AR8894	Q4043	IC	78M05HF(MPC/78M05HF)	222780055NEC		1
AR8894	Q4061	IC	TC7SHU04FU	22241638R2		1
AR8894	Q4101	IC	NJM4580M-D	22241448R2		1
AR8894	Q4102	IC	NJM4580M-D	22241448R2		1
AR8894	Q4103	IC	NJM4580M-D	22241448R2		1
AR8894	Q4104	IC	NJM4580M-D	22241448R2		1
AR8894	Q4105	TR	2SD655-E	2211705		1
AR8894	Q4105 or	TR	2SD655-F	2211706		(1)
AR8894	Q4106	TR	2SD655-E	2211705		1
AR8894	Q4106 or	TR	2SD655-F	2211706		(1)
AR8894	Q4107	TR	2SD655-E	2211705		1

AR8894	Q4107 or	TR	2SD655-F	2211706	(1)
AR8894	Q4108	TR	2SD655-E	2211705	9/18 PAGE
AR8894	Q4108 or	TR	2SD655-F	2211706	(1)
AR8894	Q4109	TR	KRA107S	2216350R2	1
AR8894	Q4110	TR	KRC107S	2216340R2	1
AR8894	Q4201	IC	NJM4580M-D	22241448R2	1
AR8894	Q4202	IC	NJM4580M-D	22241448R2	1
AR8894	Q4203	IC	NJM4580M-D	22241448R2	1
AR8894	Q4204	IC	NJM4580M-D	22241448R2	1
AR8894	Q4205	TR	2SD655-E	2211705	1
AR8894	Q4205 or	TR	2SD655-F	2211706	(1)
AR8894	Q4206	TR	2SD655-E	2211705	1
AR8894	Q4206 or	TR	2SD655-F	2211706	(1)
AR8894	Q4207	TR	2SD655-E	2211705	1
AR8894	Q4207 or	TR	2SD655-F	2211706	(1)
AR8894	Q4208	TR	2SD655-E	2211705	1
AR8894	Q4208 or	TR	2SD655-F	2211706	(1)
AR8894	Q4209	TR	KRA107S	2216350R2	1
AR8894	Q4210	TR	KRC107S	2216340R2	1
AR8894	Q4211	TR	2SD655-E	2211705	1
AR8894	Q4211 or	TR	2SD655-F	2211706	(1)
AR8894	Q4212	TR	2SD655-E	2211705	1
AR8894	Q4212 or	TR	2SD655-F	2211706	(1)
AR8894	Q4213	TR	2SD655-E	2211705	1
AR8894	Q4213 or	TR	2SD655-F	2211706	(1)
AR8894	Q4214	TR	2SD655-E	2211705	1
AR8894	Q4214 or	TR	2SD655-F	2211706	(1)
AR8894	Q4215	TR	2SC2712-O	2213143R2	1
AR8894	Q4215 or	TR	2SC2712-Y(TE85L_F)	2213144R2	(1)
AR8894	Q4215 or	TR	2SC2712-GR	2213145R2	(1)
AR8894	Q4216	TR	2SC2712-O	2213143R2	1
AR8894	Q4216 or	TR	2SC2712-Y(TE85L_F)	2213144R2	(1)
AR8894	Q4216 or	TR	2SC2712-GR	2213145R2	(1)
AR8894	Q4217	IC	NJM4580M-D	22241448R2	1
AR8894	Q4301	IC	NJM4580M-D	22241448R2	1
AR8894	Q4302	IC	NJM4580M-D	22241448R2	1
AR8894	Q4303	IC	NJM4580M-D	22241448R2	1
AR8894	Q4304	IC	NJM4580M-D	22241448R2	1
AR8894	Q4305	TR	2SD655-E	2211705	1
AR8894	Q4305 or	TR	2SD655-F	2211706	(1)
AR8894	Q4306	TR	2SD655-E	2211705	1
AR8894	Q4306 or	TR	2SD655-F	2211706	(1)
AR8894	Q4307	TR	2SD655-E	2211705	1
AR8894	Q4307 or	TR	2SD655-F	2211706	(1)
AR8894	Q4308	TR	2SD655-E	2211705	1
AR8894	Q4308 or	TR	2SD655-F	2211706	(1)
AR8894	Q4309	TR	KRA107S	2216350R2	1
AR8894	Q4310	TR	KRC107S	2216340R2	1
AR8894	Q4502	PHT CP	GP1FAV51TKBF	24120132	1
AR8894	Q4502 or	PHT CP	JST1165-001transmitting	24120142	(1)
AR8894	Q4503	IC	TC74VHCU04FT	22274004HR2TO	1
AR8894	Q6001	IC	BH7868FS	22242329R2	MPP2P 1
AR8894	Q7001	IC	MPD78F42Z5GC-315- 8BT_A	22242422R3	1
AR8894	Q7002	IC	S-80130CNMC-JKP-T2	22242354R2	1
AR8894	Q7003	TR	KRA107S	2216350R2	1
AR8894	Q7004	TR	2SD655-E	2211705	1

AR8894	Q7004 or	TR	2SD655-F	2211706		(1)
AR8894	Q7005	IC	IC74VHC1125AF1 (E K1)	22274125G1R2TO		10/18 PAGE
AR8894	Q7006	TR	2SA1162-GR	2214375R2		1
AR8894	Q7006 or	TR	2SA1162-Y(TE85R_F)	2214374R2		(1)
AR8894	Q7007	TR	2SA1162-GR	2214375R2		1
AR8894	Q7007 or	TR	2SA1162-Y(TE85R_F)	2214374R2		(1)
AR8894	Q7501	PHT CP	PC817X	24120080	MDD1N	1
AR8894	Q7502	TR	KRC107S	2216340R2	MDD1N	1
AR8894	Q7503	TR	KRC107S	2216340R2	MDD1N	1
AR8894	Q7504	IC	ICL3221ECVZ	22242268R2	MDD1N	1
AR8894	Q8001	FL TUBE	HNV-13SS15T	212253		1
AR8894	Q8001A	CUSHION	t3*10*25	28141513		2
AR8894	Q8003	IC	MFD780252GC-091- 8RT	22241989R3		1
AR8894	Q8005	TR	KRC107S	2216340R2		1
AR8894	Q8007	REMO SENS	GPTUMZ71XK0FH=12 MM	241360		1
AR8894	R4001	C-CARBON R	RN72K1J-470JE	435034704R1		1
AR8894	R4002	C-CARBON R	RN72K1J-470JE	435034704R1		1
AR8894	R4003	C-CARBON R	RN72K1J-470JE	435034704R1		1
AR8894	R4004	C-CARBON R	RN72K1J-470JE	435034704R1		1
AR8894	R4005	C-CARBON R	RN72K1J-470JE	435034704R1		1
AR8894	R4006	C-CARBON R	RN72K1J-470JE	435034704R1		1
AR8894	R4007	C-CARBON R	RN72K1J-470JE	435034704R1		1
AR8894	R4008	C-CARBON R	RN72K1J-470JE	435034704R1		1
AR8894	R4009	C-CARBON R	RN72K1J-470JE	435034704R1		1
AR8894	R4010	C-CARBON R	RN72K1J-470JE	435034704R1		1
AR8894	R4011	C-CARBON R	RN72K1J-470JE	435034704R1		1
AR8894	R4021	C-CARBON R	RN72K1J-470JE	435034704R1		1
AR8894	R4022	C-CARBON R	RN72K1J-470JE	435034704R1		1
AR8894	R4023	C-CARBON R	RN72K1J-470JE	435034704R1		1
AR8894	R4024	C-CARBON R	RN72K1J-470JE	435034704R1		1
AR8894	R4025	C-CARBON R	RN72K1J-470JE	435034704R1		1
AR8894	R4026	C-CARBON R	RN72K1J-470JE	435034704R1		1
AR8894	R4027	C-CARBON R	RN72K1J-470JE	435034704R1		1
AR8894	R4028	C-CARBON R	RN72K1J-470JE	435034704R1		1
AR8894	R4029	C-CARBON R	RN72K1J-470JE	435034704R1		1
AR8894	R4030	C-CARBON R	RN72K1J-470JE	435034704R1		1
AR8894	R4031	C-CARBON R	RN72K1J-470JE	435034704R1		1
AR8894	R4041	C-CARBON R	RN72K1J-470JE	435034704R1		1
AR8894	R4042	C-CARBON R	RN72K1J-470JE	435034704R1		1
AR8894	R4043	C-CARBON R	RN72K1J-470JE	435034704R1		1
AR8894	R4044	C-CARBON R	RN72K1J-470JE	435034704R1		1
AR8894	R4045	C-CARBON R	RN72K1J-470JE	435034704R1		1
AR8894	R4046	C-CARBON R	RN72K1J-470JE	435034704R1		1
AR8894	R4047	C-CARBON R	RN72K1J-470JE	435034704R1		1
AR8894	R4048	C-CARBON R	RN72K1J-470JE	435034704R1		1
AR8894	R4049	C-CARBON R	RN72K1J-470JE	435034704R1		1
AR8894	R4050	C-CARBON R	RN72K1J-470JE	435034704R1		1
AR8894	R4051	C-CARBON R	RN72K1J-470JE	435034704R1		1
AR8894	R4062	C-CARBON R	RN72K1J-104JE	435031044R1		1
AR8894	R4063	C-CARBON R	RN72K1J-000JE	435030004R1		1
AR8894	R4064	C-CARBON R	RN72K1J-470JE	435034704R1		1
AR8894	R4065	C-CARBON R	RN72K1J-470JE	435034704R1		1
AR8894	R4066	C-CARBON R	RN72K1J-470JE	435034704R1		1
AR8894	R4067	C-CARBON R	RN72K1J-000JE	435030004R1		1
AR8894	R4101	C-CARBON R	RN72K1J-332JE	435033324R1		1
AR8894	R4102	C-CARBON R	RN72K1J-332JE	435033324R1		1

AR8894	R4103	C-CARBON R	RN72K1J-332JE	435033324R1		1
AR8894	R4104	C-CARBON R	RN72K1J-332JE	435033324R1		11/18 PAGE
AR8894	R4109	C-CARBON R	RN72K1J-562JE	435035624R1		1
AR8894	R4110	C-CARBON R	RN72K1J-562JE	435035624R1		1
AR8894	R4111	C-CARBON R	RN72K1J-562JE	435035624R1		1
AR8894	R4112	C-CARBON R	RN72K1J-562JE	435035624R1		1
AR8894	R4113	C-CARBON R	RN72K1J-103JE	435031034R1		1
AR8894	R4114	C-CARBON R	RN72K1J-103JE	435031034R1		1
AR8894	R4115	C-CARBON R	RN72K1J-103JE	435031034R1		1
AR8894	R4116	C-CARBON R	RN72K1J-103JE	435031034R1		1
AR8894	R4117	C-CARBON R	RN72K1J-152JE	435031524R1		1
AR8894	R4118	C-CARBON R	RN72K1J-152JE	435031524R1		1
AR8894	R4119	C-CARBON R	RN72K1J-223JE	435032234R1		1
AR8894	R4120	C-CARBON R	RN72K1J-223JE	435032234R1		1
AR8894	R4121	C-CARBON R	RN72K1J-223JE	435032234R1		1
AR8894	R4122	C-CARBON R	RN72K1J-223JE	435032234R1		1
AR8894	R4123	C-CARBON R	RN72K1J-152JE	435031524R1		1
AR8894	R4124	C-CARBON R	RN72K1J-152JE	435031524R1		1
AR8894	R4125	C-CARBON R	RN72K1J-152JE	435031524R1		1
AR8894	R4126	C-CARBON R	RN72K1J-152JE	435031524R1		1
AR8894	R4127	C-CARBON R	RN72K1J-223JE	435032234R1		1
AR8894	R4128	C-CARBON R	RN72K1J-223JE	435032234R1		1
AR8894	R4129	C-CARBON R	RN72K1J-223JE	435032234R1		1
AR8894	R4130	C-CARBON R	RN72K1J-223JE	435032234R1		1
AR8894	R4131	C-CARBON R	RN72K1J-000JE	435030004R1		1
AR8894	R4132	C-CARBON R	RN72K1J-000JE	435030004R1		1
AR8894	R4133	C-CARBON R	RN72K1J-000JE	435030004R1		1
AR8894	R4134	C-CARBON R	RN72K1J-000JE	435030004R1		1
AR8894	R4135	C-CARBON R	RN72K1J-221JE	435032214R1		1
AR8894	R4136	C-CARBON R	RN72K1J-221JE	435032214R1		1
AR8894	R4137	C-CARBON R	RN72K1J-221JE	435032214R1		1
AR8894	R4138	C-CARBON R	RN72K1J-221JE	435032214R1		1
AR8894	R4139	C-CARBON R	RN72K1J-000JE	435030004R1		1
AR8894	R4140	C-CARBON R	RN72K1J-000JE	435030004R1		1
AR8894	R4141	C-CARBON R	RN72K1J-222JE	435032224R1		1
AR8894	R4142	C-CARBON R	RN72K1J-222JE	435032224R1		1
AR8894	R4143	C-CARBON R	RN72K1J-222JE	435032224R1		1
AR8894	R4144	C-CARBON R	RN72K1J-222JE	435032224R1		1
AR8894	R4145	C-CARBON R	RN72K1J-474JE	435034744R1		1
AR8894	R4146	C-CARBON R	RN72K1J-474JE	435034744R1		1
AR8894	R4149	C-CARBON R	RN72K1J-474JE	435034744R1		1
AR8894	R4150	C-CARBON R	RN72K1J-474JE	435034744R1		1
AR8894	R4151	METAL O R	RS1/2WBJ-22	443522204		1
AR8894	R4152	METAL O R	RS1/2WBJ-22	443522204		1
AR8894	R4155	C-CARBON R	RN72K1J-221JE	435032214R1	MPP2P	1
AR8894	R4156	C-CARBON R	RN72K1J-221JE	435032214R1	MPP2P	1
AR8894	R4201	C-CARBON R	RN72K1J-332JE	435033324R1		1
AR8894	R4202	C-CARBON R	RN72K1J-332JE	435033324R1		1
AR8894	R4203	C-CARBON R	RN72K1J-332JE	435033324R1		1
AR8894	R4204	C-CARBON R	RN72K1J-332JE	435033324R1		1
AR8894	R4209	C-CARBON R	RN72K1J-392JE	435033924R1		1
AR8894	R4210	C-CARBON R	RN72K1J-392JE	435033924R1		1
AR8894	R4211	C-CARBON R	RN72K1J-392JE	435033924R1		1
AR8894	R4212	C-CARBON R	RN72K1J-392JE	435033924R1		1
AR8894	R4213	C-CARBON R	RN72K1J-103JE	435031034R1		1
AR8894	R4214	C-CARBON R	RN72K1J-103JE	435031034R1		1

AR8894	R4215	C-CARBON R	RN72K1J-103JE	435031034R1	1
AR8894	R4216	C-CARBON R	RN72K1J-103JE	435031034R1	12/18 PAGE
AR8894	R4217	C-CARBON R	RN72K1J-152JE	435031524R1	1
AR8894	R4218	C-CARBON R	RN72K1J-152JE	435031524R1	1
AR8894	R4219	C-CARBON R	RN72K1J-223JE	435032234R1	1
AR8894	R4220	C-CARBON R	RN72K1J-223JE	435032234R1	1
AR8894	R4221	C-CARBON R	RN72K1J-223JE	435032234R1	1
AR8894	R4222	C-CARBON R	RN72K1J-223JE	435032234R1	1
AR8894	R4223	C-CARBON R	RN72K1J-152JE	435031524R1	1
AR8894	R4224	C-CARBON R	RN72K1J-152JE	435031524R1	1
AR8894	R4225	C-CARBON R	RN72K1J-152JE	435031524R1	1
AR8894	R4226	C-CARBON R	RN72K1J-152JE	435031524R1	1
AR8894	R4227	C-CARBON R	RN72K1J-223JE	435032234R1	1
AR8894	R4228	C-CARBON R	RN72K1J-223JE	435032234R1	1
AR8894	R4229	C-CARBON R	RN72K1J-223JE	435032234R1	1
AR8894	R4230	C-CARBON R	RN72K1J-223JE	435032234R1	1
AR8894	R4231	C-CARBON R	RN72K1J-000JE	435030004R1	1
AR8894	R4232	C-CARBON R	RN72K1J-000JE	435030004R1	1
AR8894	R4233	C-CARBON R	RN72K1J-472JE	435034724R1	1
AR8894	R4234	C-CARBON R	RN72K1J-472JE	435034724R1	1
AR8894	R4235	C-CARBON R	RN72K1J-221JE	435032214R1	1
AR8894	R4236	C-CARBON R	RN72K1J-221JE	435032214R1	1
AR8894	R4237	C-CARBON R	RN72K1J-221JE	435032214R1	1
AR8894	R4238	C-CARBON R	RN72K1J-221JE	435032214R1	1
AR8894	R4239	C-CARBON R	RN72K1J-000JE	435030004R1	1
AR8894	R4240	C-CARBON R	RN72K1J-000JE	435030004R1	1
AR8894	R4241	C-CARBON R	RN72K1J-222JE	435032224R1	1
AR8894	R4242	C-CARBON R	RN72K1J-222JE	435032224R1	1
AR8894	R4243	C-CARBON R	RN72K1J-222JE	435032224R1	1
AR8894	R4244	C-CARBON R	RN72K1J-222JE	435032224R1	1
AR8894	R4245	C-CARBON R	RN72K1J-474JE	435034744R1	1
AR8894	R4246	C-CARBON R	RN72K1J-474JE	435034744R1	1
AR8894	R4249	C-CARBON R	RN72K1J-474JE	435034744R1	1
AR8894	R4250	C-CARBON R	RN72K1J-474JE	435034744R1	1
AR8894	R4251	METAL O R	RS1/2WBJ-22	443522204	1
AR8894	R4252	METAL O R	RS1/2WBJ-22	443522204	1
AR8894	R4255	C-CARBON R	RN72K1J-123JE	435031234R1	1
AR8894	R4256	C-CARBON R	RN72K1J-123JE	435031234R1	1
AR8894	R4257	C-CARBON R	RN72K1J-221JE	435032214R1	1
AR8894	R4258	C-CARBON R	RN72K1J-221JE	435032214R1	1
AR8894	R4259	C-CARBON R	RN72K1J-221JE	435032214R1	1
AR8894	R4260	C-CARBON R	RN72K1J-221JE	435032214R1	1
AR8894	R4261	C-CARBON R	RN72K1J-222JE	435032224R1	1
AR8894	R4262	C-CARBON R	RN72K1J-222JE	435032224R1	1
AR8894	R4263	C-CARBON R	RN72K1J-222JE	435032224R1	1
AR8894	R4264	C-CARBON R	RN72K1J-222JE	435032224R1	1
AR8894	R4267	C-CARBON R	RN72K1J-474JE	435034744R1	1
AR8894	R4268	C-CARBON R	RN72K1J-474JE	435034744R1	1
AR8894	R4269	C-CARBON R	RN72K1J-000JE	435030004R1	1
AR8894	R4270	C-CARBON R	RN72K1J-000JE	435030004R1	1
AR8894	R4271	C-CARBON R	RN72K1J-222JE	435032224R1	1
AR8894	R4272	C-CARBON R	RN72K1J-222JE	435032224R1	1
AR8894	R4273	C-CARBON R	RN72K1J-000JE	435030004R1	1
AR8894	R4274	C-CARBON R	RN72K1J-474JE	435034744R1	1
AR8894	R4275	C-CARBON R	RN72K1J-474JE	435034744R1	1
AR8894	R4277	C-CARBON R	RN72K1J-474JE	435034744R1	1

AR8894	R4278	C-CARBON R	RN72K1J-474JE	435034744R1	1
AR8894	R4301	C-CARBON R	RN72K1J-332JE	435033324R1	13/18 PAGE
AR8894	R4302	C-CARBON R	RN72K1J-332JE	435033324R1	1
AR8894	R4303	C-CARBON R	RN72K1J-332JE	435033324R1	1
AR8894	R4304	C-CARBON R	RN72K1J-332JE	435033324R1	1
AR8894	R4309	C-CARBON R	RN72K1J-562JE	435035624R1	1
AR8894	R4310	C-CARBON R	RN72K1J-562JE	435035624R1	1
AR8894	R4311	C-CARBON R	RN72K1J-562JE	435035624R1	1
AR8894	R4312	C-CARBON R	RN72K1J-562JE	435035624R1	1
AR8894	R4313	C-CARBON R	RN72K1J-103JE	435031034R1	1
AR8894	R4314	C-CARBON R	RN72K1J-103JE	435031034R1	1
AR8894	R4315	C-CARBON R	RN72K1J-103JE	435031034R1	1
AR8894	R4316	C-CARBON R	RN72K1J-103JE	435031034R1	1
AR8894	R4317	C-CARBON R	RN72K1J-152JE	435031524R1	1
AR8894	R4318	C-CARBON R	RN72K1J-152JE	435031524R1	1
AR8894	R4319	C-CARBON R	RN72K1J-223JE	435032234R1	1
AR8894	R4320	C-CARBON R	RN72K1J-223JE	435032234R1	1
AR8894	R4321	C-CARBON R	RN72K1J-223JE	435032234R1	1
AR8894	R4322	C-CARBON R	RN72K1J-223JE	435032234R1	1
AR8894	R4323	C-CARBON R	RN72K1J-152JE	435031524R1	1
AR8894	R4324	C-CARBON R	RN72K1J-152JE	435031524R1	1
AR8894	R4325	C-CARBON R	RN72K1J-152JE	435031524R1	1
AR8894	R4326	C-CARBON R	RN72K1J-152JE	435031524R1	1
AR8894	R4327	C-CARBON R	RN72K1J-223JE	435032234R1	1
AR8894	R4328	C-CARBON R	RN72K1J-223JE	435032234R1	1
AR8894	R4329	C-CARBON R	RN72K1J-223JE	435032234R1	1
AR8894	R4330	C-CARBON R	RN72K1J-223JE	435032234R1	1
AR8894	R4331	C-CARBON R	RN72K1J-000JE	435030004R1	1
AR8894	R4332	C-CARBON R	RN72K1J-000JE	435030004R1	1
AR8894	R4333	C-CARBON R	RN72K1J-000JE	435030004R1	1
AR8894	R4334	C-CARBON R	RN72K1J-000JE	435030004R1	1
AR8894	R4335	C-CARBON R	RN72K1J-221JE	435032214R1	1
AR8894	R4336	C-CARBON R	RN72K1J-221JE	435032214R1	1
AR8894	R4337	C-CARBON R	RN72K1J-221JE	435032214R1	1
AR8894	R4338	C-CARBON R	RN72K1J-221JE	435032214R1	1
AR8894	R4339	C-CARBON R	RN72K1J-000JE	435030004R1	1
AR8894	R4340	C-CARBON R	RN72K1J-000JE	435030004R1	1
AR8894	R4341	C-CARBON R	RN72K1J-222JE	435032224R1	1
AR8894	R4342	C-CARBON R	RN72K1J-222JE	435032224R1	1
AR8894	R4343	C-CARBON R	RN72K1J-222JE	435032224R1	1
AR8894	R4344	C-CARBON R	RN72K1J-222JE	435032224R1	1
AR8894	R4345	C-CARBON R	RN72K1J-474JE	435034744R1	1
AR8894	R4346	C-CARBON R	RN72K1J-474JE	435034744R1	1
AR8894	R4349	C-CARBON R	RN72K1J-474JE	435034744R1	1
AR8894	R4350	C-CARBON R	RN72K1J-474JE	435034744R1	1
AR8894	R4351	METAL O R	RS1/2WBJ-22	443522204	1
AR8894	R4352	METAL O R	RS1/2WBJ-22	443522204	1
AR8894	R4501	C-CARBON R	RN72K1J-101JE	435031014R1	1
AR8894	R4503	C-CARBON R	RN72K1J-474JE	435034744R1	1
AR8894	R4505	C-CARBON R	RN72K1J-271JE	435032714R1	1
AR8894	R4506	C-CARBON R	RN72K1J-181JE	435031814R1	1
AR8894	R4507	C-CARBON R	RN72K1J-181JE	435031814R1	1
AR8894	R4510	C-CARBON R	RN72K1J-101JE	435031014R1	1
AR8894	R6001	C-CARBON R	RN72K1J-000JE	435030004R1	MPP2P 1
AR8894	R6002	C-CARBON R	RN72K1J-750JE	435037504R1	MPP2P 1
AR8894	R6003	C-CARBON R	RN72K1J-000JE	435030004R1	MPP2P 1

AR8894	R6004	C-CARBON R	RN72K1J-750JE	435037504R1	MPP2P	1
AR8894	R6005	C-CARBON R	RN72K1J-102JE	435031024R1	MPP2P	14/18 PAGE
AR8894	R6006	C-CARBON R	RN72K1J-000JE	435030004R1	MPP2P	1
AR8894	R6007	C-CARBON R	RN72K1J-750JE	435037504R1	MPP2P	1
AR8894	R6008	C-CARBON R	RN72K1J-222JE	435032224R1	MPP2P	1
AR8894	R6009	C-CARBON R	RN72K1J-000JE	435030004R1	MPP2P	1
AR8894	R6010	C-CARBON R	RN72K1J-750JE	435037504R1	MPP2P	1
AR8894	R6011	C-CARBON R	RN72K1J-102JE	435031024R1	MPP2P	1
AR8894	R6012	C-CARBON R	RN72K1J-222JE	435032224R1	MPP2P	1
AR8894	R6013	C-CARBON R	RN72K1J-221JE	435032214R1	MPP2P	1
AR8894	R6014	C-CARBON R	RN72K1J-221JE	435032214R1	MPP2P	1
AR8894	R7001	C-CARBON R	RN72K1J-000JE	435030004R1		1
AR8894	R7002	C-CARBON R	RN72K1J-000JE	435030004R1		1
AR8894	R7003	C-CARBON R	RN72K1J-000JE	435030004R1		1
AR8894	R7004	C-CARBON R	RN72K1J-473JE	435034734R1		1
AR8894	R7005	C-CARBON R	RN72K1J-472JE	435034724R1	MDD1N	1
AR8894	R7005	C-CARBON R	RN72K1J-562JE	435035624R1	MUA4P	1
AR8894	R7005	C-CARBON R	RN72K1J-562JE	435035624R1	MUT3P	1
AR8894	R7005	C-CARBON R	RN72K1J-562JE	435035624R1	MUK3N	1
AR8894	R7005	C-CARBON R	RN72K1J-562JE	435035624R1	MPP2P	1
AR8894	R7006	C-CARBON R	RN72K1J-333JE	435033334R1	MDD1N	1
AR8894	R7006	C-CARBON R	RN72K1J-332JE	435033324R1	MUA4P	1
AR8894	R7006	C-CARBON R	RN72K1J-332JE	435033324R1	MUT3P	1
AR8894	R7006	C-CARBON R	RN72K1J-332JE	435033324R1	MUK3N	1
AR8894	R7006	C-CARBON R	RN72K1J-332JE	435033324R1	MPP2P	1
AR8894	R7007	C-CARBON R	RN72K1J-103JE	435031034R1		1
AR8894	R7008	C-CARBON R	RN72K1J-470JE	435034704R1		1
AR8894	R7009	C-CARBON R	RN72K1J-470JE	435034704R1		1
AR8894	R7010	C-CARBON R	RN72K1J-470JE	435034704R1		1
AR8894	R7011	C-CARBON R	RN72K1J-470JE	435034704R1		1
AR8894	R7012	C-CARBON R	RN72K1J-470JE	435034704R1		1
AR8894	R7013	C-CARBON R	RN72K1J-470JE	435034704R1		1
AR8894	R7014	C-CARBON R	RN72K1J-470JE	435034704R1		1
AR8894	R7015	C-CARBON R	RN72K1J-470JE	435034704R1		1
AR8894	R7016	C-CARBON R	RN72K1J-470JE	435034704R1		1
AR8894	R7017	C-CARBON R	RN72K1J-103JE	435031034R1		1
AR8894	R7018	C-CARBON R	RN72K1J-103JE	435031034R1		1
AR8894	R7020	C-CARBON R	RN72K1J-472JE	435034724R1		1
AR8894	R7021	C-CARBON R	RN72K1J-332JE	435033324R1		1
AR8894	R7022	C-CARBON R	RN72K1J-471JE	435034714R1		1
AR8894	R7024	C-CARBON R	RN72K1J-103JE	435031034R1		1
AR8894	R7025	C-CARBON R	RN72K1J-103JE	435031034R1		1
AR8894	R7026	C-CARBON R	RN72K1J-470JE	435034704R1		1
AR8894	R7027	C-CARBON R	RN72K1J-470JE	435034704R1		1
AR8894	R7029	C-CARBON R	RN72K1J-103JE	435031034R1		1
AR8894	R7030	C-CARBON R	RN72K1J-103JE	435031034R1		1
AR8894	R7031	C-CARBON R	RN72K1J-103JE	435031034R1		1
AR8894	R7032	C-CARBON R	RN72K1J-474JE	435034744R1		1
AR8894	R7033	C-CARBON R	RN72K1J-473JE	435034734R1		1
AR8894	R7034	C-CARBON R	RN72K1J-272JE	435032724R1		1
AR8894	R7035	C-CARBON R	RN72K1J-470JE	435034704R1		1
AR8894	R7036	C-CARBON R	RN72K1J-470JE	435034704R1		1
AR8894	R7037	C-CARBON R	RN72K1J-470JE	435034704R1		1
AR8894	R7038	C-CARBON R	RN72K1J-470JE	435034704R1		1
AR8894	R7040	C-CARBON R	RN72K1J-103JE	435031034R1		1
AR8894	R7043	C-CARBON R	RN72K1J-103JE	435031034R1		1

AR8894	R7044	C-CARBON R	RN72K1J-103JE	435031034R1		1
AR8894	R7045	C-CARBON R	RN72K1J-103JE	435031034R1		15/18 PAGE
AR8894	R7047	C-CARBON R	RN72K1J-470JE	435034704R1		1
AR8894	R7048	C-CARBON R	RN72K1J-103JE	435031034R1		1
AR8894	R7049	C-CARBON R	RN72K1J-000JE	435030004R1		1
AR8894	R7050	C-CARBON R	RN72K1J-103JE	435031034R1	MUA4P	1
AR8894	R7050	C-CARBON R	RN72K1J-332JE	435033324R1	MUT3P	1
AR8894	R7050	C-CARBON R	RN72K1J-103JE	435031034R1	MUK3N	1
AR8894	R7050	C-CARBON R	RN72K1J-332JE	435033324R1	MPP2P	1
AR8894	R7051	C-CARBON R	RN72K1J-563JE	435035634R1		1
AR8894	R7053	C-CARBON R	RN72K1J-333JE	435033334R1	MDD1N	1
AR8894	R7053	C-CARBON R	RN72K1J-333JE	435033334R1	MUA4P	1
AR8894	R7053	C-CARBON R	RN72K1J-333JE	435033334R1	MUT3P	1
AR8894	R7053	C-CARBON R	RN72K1J-333JE	435033334R1	MUK3N	1
AR8894	R7053	C-CARBON R	RN72K1J-562JE	435035624R1	MPP2P	1
AR8894	R7054	C-CARBON R	RN72K1J-000JE	435030004R1	MDD1N	1
AR8894	R7054	C-CARBON R	RN72K1J-103JE	435031034R1	MUT3P	1
AR8894	R7054	C-CARBON R	RN72K1J-332JE	435033324R1	MUK3N	1
AR8894	R7054	C-CARBON R	RN72K1J-562JE	435035624R1	MPP2P	1
AR8894	R7055	C-CARBON R	RN72K1J-333JE	435033334R1		1
AR8894	R7057	C-CARBON R	RN72K1J-472JE	435034724R1	MDD1N	1
AR8894	R7057	C-CARBON R	RN72K1J-472JE	435034724R1	MUA4P	1
AR8894	R7057	C-CARBON R	RN72K1J-472JE	435034724R1	MUT3P	1
AR8894	R7057	C-CARBON R	RN72K1J-472JE	435034724R1	MUK3N	1
AR8894	R7057	C-CARBON R	RN72K1J-332JE	435033324R1	MPP2P	1
AR8894	R7058	METAL O R	RS1/2WBJ-12	443521204		1
AR8894	R7059	METAL O R	RS1/2WBJ-12	443521204		1
AR8894	R7060	C-CARBON R	RN72K1J-102JE	435031024R1		1
AR8894	R7061	C-CARBON R	RN72K1J-272JE	435032724R1		1
AR8894	R7062	C-CARBON R	RN72K1J-471JE	435034714R1		1
AR8894	R7063	C-CARBON R	RN72K1J-101JE	435031014R1		1
AR8894	R7064	C-CARBON R	RN72K1J-101JE	435031014R1		1
AR8894	R7065	C-CARBON R	RN72K1J-101JE	435031014R1		1
AR8894	R7066	C-CARBON R	RN72K1J-101JE	435031014R1		1
AR8894	R7067	C-CARBON R	RN72K1J-470JE	435034704R1		1
AR8894	R7068	C-CARBON R	RN72K1J-000JE	435030004R1		1
AR8894	R7071	C-CARBON R	RN72K1J-101JE	435031014R1		1
AR8894	R7072	C-CARBON R	RN72K1J-101JE	435031014R1		1
AR8894	R7073	C-CARBON R	RN72K1J-103JE	435031034R1		1
AR8894	R7074	C-CARBON R	RN72K1J-103JE	435031034R1		1
AR8894	R7075	C-CARBON R	RN72K1J-103JE	435031034R1		1
AR8894	R7079	C-CARBON R	RN72K1J-470JE	435034704R1		1
AR8894	R7080	C-CARBON R	RN72K1J-470JE	435034704R1		1
AR8894	R7081	C-CARBON R	RN72K1J-470JE	435034704R1		1
AR8894	R7082	C-CARBON R	RN72K1J-000JE	435030004R1		1
AR8894	R7083	C-CARBON R	RN72K1J-103JE	435031034R1		1
AR8894	R7084	C-CARBON R	RN72K1J-470JE	435034704R1		1
AR8894	R7085	C-CARBON R	RN72K1J-470JE	435034704R1		1
AR8894	R7086	C-CARBON R	RN72K1J-000JE	435030004R1		1
AR8894	R7087	C-CARBON R	RN72K1J-470JE	435034704R1		1
AR8894	R7088	C-CARBON R	RN72K1J-470JE	435034704R1		1
AR8894	R7089	C-CARBON R	RN72K1J-473JE	435034734R1		1
AR8894	R7090	C-CARBON R	RN72K1J-000JE	435030004R1		1
AR8894	R7501	C-CARBON R	RN72K1J-332JE	435033324R1	MDD1N	1
AR8894	R7502	C-CARBON R	RN72K1J-000JE	435030004R1	MDD1N	1
AR8894	R7503	C-CARBON R	RN72K1J-332JE	435033324R1	MDD1N	1

AR8894	R7504	C-CARBON R	RN72K1J-103JE	435031034R1	MDD1N	1
AR8894	R7505	C-CARBON R	RN72K1J-101JE	435031014R1	MDD1N	16/18 PAGE
AR8894	R7506	C-CARBON R	RN72K1J-000JE	435030004R1	MDD1N	1
AR8894	R7507	C-CARBON R	RN72K1J-101JE	435031014R1	MDD1N	1
AR8894	R7510	C-CARBON R	RN72K1J-000JE	435030004R1	MDD1N	1
AR8894	R7512	C-CARBON R	RN72K1J-103JE	435031034R1	MDD1N	1
AR8894	R7522	C-CARBON R	RN72K1J-470JE	435034704R1	MDD1N	1
AR8894	R7526	C-CARBON R	RN72K1J-103JE	435031034R1	MDD1N	1
AR8894	R7527	C-CARBON R	RN72K1J-470JE	435034704R1	MDD1N	1
AR8894	R7528	C-CARBON R	RN72K1J-470JE	435034704R1	MDD1N	1
AR8894	R8001	C-CARBON R	RN72K1J-391JE	435033914R1		1
AR8894	R8002	C-CARBON R	RN72K1J-471JE	435034714R1		1
AR8894	R8003	C-CARBON R	RN72K1J-821JE	435038214R1		1
AR8894	R8004	C-CARBON R	RN72K1J-102JE	435031024R1		1
AR8894	R8005	C-CARBON R	RN72K1J-182JE	435031824R1		1
AR8894	R8006	C-CARBON R	RN72K1J-392JE	435033924R1		1
AR8894	R8007	C-CARBON R	RN72K1J-103JE	435031034R1		1
AR8894	R8008	C-CARBON R	RN72K1J-000JE	435030004R1		1
AR8894	R8009	C-CARBON R	RN72K1J-472JE	435034724R1		1
AR8894	R8010	C-CARBON R	RN72K1J-391JE	435033914R1		1
AR8894	R8011	C-CARBON R	RN72K1J-471JE	435034714R1		1
AR8894	R8012	C-CARBON R	RN72K1J-821JE	435038214R1		1
AR8894	R8013	C-CARBON R	RN72K1J-272JE	435032724R1		1
AR8894	R8014	C-CARBON R	RN72K1J-272JE	435032724R1		1
AR8894	R8017	C-CARBON R	RN72K1J-391JE	435033914R1		1
AR8894	R8018	C-CARBON R	RN72K1J-471JE	435034714R1		1
AR8894	R8019	C-CARBON R	RN72K1J-821JE	435038214R1		1
AR8894	R8020	C-CARBON R	RN72K1J-102JE	435031024R1		1
AR8894	R8021	C-CARBON R	RN72K1J-182JE	435031824R1		1
AR8894	R8022	C-CARBON R	RN72K1J-392JE	435033924R1		1
AR8894	R8023	C-CARBON R	RN72K1J-103JE	435031034R1		1
AR8894	R8024	C-CARBON R	RN72K1J-470JE	435034704R1		1
AR8894	R8025	C-CARBON R	RN72K1J-470JE	435034704R1		1
AR8894	R8026	C-CARBON R	RN72K1J-101JE	435031014R1		1
AR8894	R8027	C-CARBON R	RN72K1J-272JE	435032724R1		1
AR8894	R8028	C-CARBON R	RN72K1J-272JE	435032724R1		1
AR8894	R8029	C-CARBON R	RN72K1J-103JE	435031034R1		1
AR8894	R8032	C-CARBON R	RN72K1J-470JE	435034704R1		1
AR8894	R8033	C-CARBON R	RN72K1J-101JE	435031014R1		1
AR8894	R8034	C-CARBON R	RN72K1J-471JE	435034714R1		1
AR8894	R8035	C-CARBON R	RN72K1J-333JE	435033334R1		1
AR8894	R8036	C-CARBON R	RN72K1J-471JE	435034714R1		1
AR8894	R8037	C-CARBON R	RN72K1J-391JE	435033914R1		1
AR8894	R8038	C-CARBON R	RN72K1J-471JE	435034714R1		1
AR8894	R8039	C-CARBON R	RN72K1J-391JE	435033914R1		1
AR8894	R8041	C-CARBON R	RN72K1J-101JE	435031014R1		1
AR8894	R8042	C-CARBON R	RN72K1J-101JE	435031014R1		1
AR8894	R8051	C-CARBON R	RN72K1J-332JE	435033324R1		1
AR8894	S4001	SLIDE SW	NSS-22155	25065414		1
AR8894	S8001	PUSH SW	NPS-111-S681	25035718		1
AR8894	S8002	PUSH SW	NPS-111-S681	25035718		1
AR8894	S8003	PUSH SW	NPS-111-S681	25035718		1
AR8894	S8004	PUSH SW	NPS-111-S681	25035718		1
AR8894	S8005	PUSH SW	NPS-111-S681	25035718		1
AR8894	S8006	PUSH SW	NPS-111-S681	25035718		1
AR8894	S8007	PUSH SW	NPS-111-S681	25035718		1

AR8894	S8008	PUSH SW	NPS-111-S681	25035718	1
AR8894	S8009	PUSH SW	NPS-111-S681	25035718	17/18 PAGE
AR8894	S8010	PUSH SW	NPS-111-S681	25035718	1
AR8894	S8011	PUSH SW	NPS-111-S681	25035718	1
AR8894	S8012	PUSH SW	NPS-111-S681	25035718	1
AR8894	S8013	PUSH SW	NPS-111-S681	25035718	1
AR8894	S8014	PUSH SW	NPS-111-S681	25035718	1
AR8894	S8015	PUSH SW	NPS-111-S681	25035718	1
AR8894	X7001	CERA LOCK	EFOEC1255T4	3010437	1
AR8894	X8001	CERA LOCK	CSTLS5M00G56-A0	3010406	1

ONKYO CORPORATION

Sales & Product Planning Div. : 2-1, Nisshin-cho, Neyagawa-shi, OSAKA 572-8540, JAPAN
Tel: 072-831-8023 Fax: 072-831-8124

ONKYO U.S.A. CORPORATION

18 Park Way, Upper Saddle River, N.J. 07458, U.S.A.
Tel: 201-785-2600 Fax: 201-785-2650 <http://www.us.onkyo.com/>

ONKYO EUROPE ELECTRONICS GmbH

Liegnitzerstrasse 6, 82194 Groebenzell, GERMANY
Tel: +49-8142-4401-0 Fax: +49-8142-4401-555 <http://www.eu.onkyo.com/>

ONKYO EUROPE UK Office

Suite 1, Gregories Court, Gregories Road, Beaconsfield, Buckinghamshire, HP9 1HQ
UNITED KINGDOM Tel: +44-(0)1494-681515 Fax: +44(0)-1494-680452

ONKYO CHINA LIMITED

Units 2102-2107, Metroplaza Tower I, 223 Hing Fong Road, Kwai Chung,
N.T., HONG KONG Tel: 852-2429-3118 Fax: 852-2428-9039
<http://www.ch.onkyo.com/>

