

ONKYO® SERVICE MANUAL

COMPACT DISC PLAYER MODEL DX-1400

Black model

BUDN, BUD	120V AC, 60Hz
BUG	220V AC, 50Hz
BUU	110/120/220/240V AC, 50/60Hz
BUQA, BUQB	240V AC, 50Hz

SAFETY-RELATED COMPONENT WARNING!!

COMPONENTS IDENTIFIED BY MARK  ON THE SCHEMATIC DIAGRAM AND IN THE PARTS LIST ARE CRITICAL FOR RISK OF FIRE AND ELECTRIC SHOCK. REPLACE THESE COMPONENTS WITH ONKYO PARTS WHOSE PART NUMBERS APPEAR AS SHOWN IN THIS MANUAL.

MAKE LEAKAGE-CURRENT OR RESISTANCE MEASUREMENTS TO DETERMINE THAT EXPOSED PARTS ARE ACCEPTABLY INSULATED FROM THE SUPPLY CIRCUIT BEFORE RETURNING THE APPLIANCE TO THE CUSTOMER.

SPECIFICATIONS

Signal readout system:	Optical non-contact
Reading rotation:	About 500~200 r.p.m. (constant linear velocity)
Linear velocity:	1.2~1.4m/s
Error correction system:	Cross interleave readsolomon code
Decoded bits:	18 bits linear
Sampling frequency:	352.8kHz (8 times oversampling)
Number of channels:	2 (Stereo)
Frequency response:	5Hz~20kHz
Total harmonic distortion:	0.004% (at 1kHz)
Dynamic range:	98dB
Signal to noise ratio:	100dB
Channel separation:	100dB (at 1kHz)
Wow and Flutter:	Below threshold of measurability
Power consumption:	12 watts
Output level:	2 volts r.m.s.
Dimensions (W×H×D):	435×112×301mm 17-1/8"×4-7/16"×11-13/16"
Weight:	4.6kg. 11-13/16 lbs.

Specifications are subject to change without notice.



TABLE OF CONTENTS

Specifications	1
Service procedures	2
Note on compact disc	2
Caution of replacement of optical pickup	3
Protection of eyes from laser beam during servicing	4
Laser warning label	4
Mechanism exploded view	5
Exploded view	8
Parts list	9
IC block diagrams and descriptions	10
Adjustment procedures	18
Printed circuit board view	21
Pc board-parts list	22
Schematic diagram	23
Block diagram	27
Packing view	28

NOTE ON COMPACT DISC

• Holding Compact Discs

Hold Compact Discs by the edges so that you do not touch the surface of disc. Remember that the side of the disc with the "rainbow" reflection is the side containing the audio information.

Do not attach tape or paper to the label side of the disc and always be careful not to leave fingerprints on the side that is played.

• Storing Compact Discs

Store Compact Discs in a location protected from direct sunlight, high heat and humidity and extremely high and low temperatures. Discs should never be left in the trunk or interior of an automobile in the sun since the temperature can become very high in such a closed environment.

Always store Compact Discs in the holders in which they were sold. Never leave a disc in the player's disc holder for a long period of time.

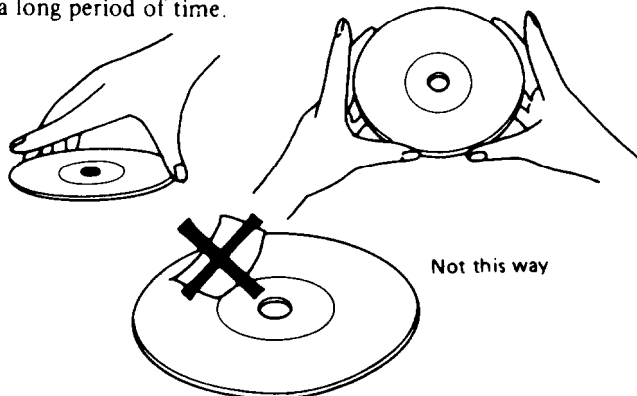

SERVICE PROCEDURES

1. Safety-check out

After correcting the original service problem, perform the following safety check before releasing the set to the customer:

Connect the insulating-resistance tester between the plug of power supply cable and chassis.

Specifications: more than 10Mohm at 500V.

2. Voltage selector (back panel)

Worldwide models are equipped with a voltage selector to conform with local power supplies. Be sure to set this selector to match the voltage of the power supply in your area before turning the power switch on. Voltage is changed by turning the voltage selector with a screwdriver or similar instrument to the 110V, 120V, 220V or 240V position. Confirm that the selector has been set to the correct position before turning the power switch on. If there is no voltage selector switch on the unit you have purchased, it can only be used in areas where the power supply voltage is the same as that of the unit.

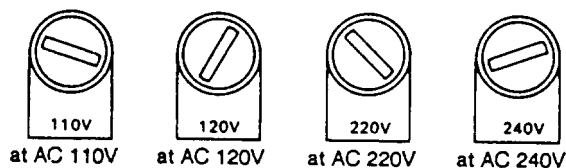

• Cleaning Compact Discs

Before playing a disc wipe off the playing surface with a soft cloth to remove dust and other soil. Wipe the surface in straight lines from the center of the disc outward, not in a circular motion as you would with a phonograph record.

Do not use benzene, chemical cleansers or phonograph record cleaning solutions to clean Compact Discs. Also avoid static electricity prevention solutions since they can damage the surface of Compact Discs.

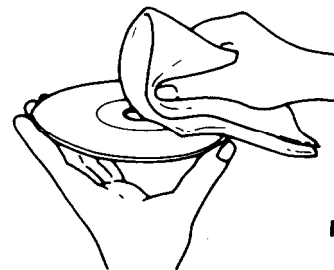

Fig. 9

Problems Caused by Dew

Dew can form inside a Compact player when it is brought from a cold environment into a warm room, when a room is rapidly heated and if a player is left in a humid environment.

This dew can prevent the laser pickup from reading the data contained in the pits in the disc surface. If the player does not operate properly because of dew, remove the disc and leave the player's power switch on for about one hour to remove all moisture.

CAUTION ON REPLACEMENT OF OPTICAL PICKUP

The laser diode in the optical pickup block is so sensitive to static electricity, surge current and etc. that the components are liable to be broken down or its reliability remarkably deteriorated.

During repair, carefully take the following precautions. (The following precautions are included in the service parts).

PRECAUTIONS

1. Ground for the work-desk.

Place a conductive sheet such as a sheet of copper (with impedance lower than $10^6 \Omega$) on the work-desk and place the set on the conductive sheet so that the chassis.

2. Grounding for the test equipment and tools.

Test equipments and toolings should be grounded in order that their ground level is the same the ground of the power source.

3. Grounding for the human body.

Be sure to put on a wrist-strap for grounding whose other end is grounded.

Be particularly careful when the workers wear synthetic fiber clothes, or air is dry.

4. Select a soldering iron that permits no leakage and have the tip of the iron well-grounded.

5. Do not check the laser diode terminals with the probe of a circuit tester or oscilloscope.

Care should be taken with the optical pickup.

The optical pickup is sensitive to static electricity, surge currents, and other high electrical noise, and because there is the possibility of damage to performance, in the handling of the pickup, the utmost care must be taken, particularly with regard to static electricity.

1. When checking the laser terminal, avoid making connections using the probes of a tester or oscilloscope, or an ordinary power supply.
2. When replacing the optical pickup, first short the LD terminals and remove the connector. Also, when attaching the new optical pickup, after attaching the connector, unsolder the LD terminals.

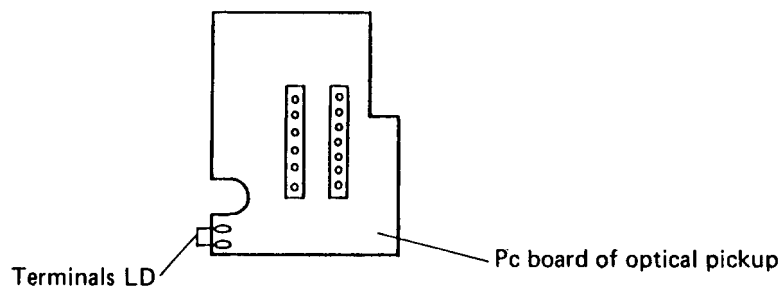

PROTECTION OF EYES FROM LASER BEAM DURING SERVICING

This set employs a laser. Therefore, be sure to follow carefully the instructions below when servicing.

WARNING!!

WHEN SERVICING, DO NOT APPROACH THE LASER EXIT WITH THE EYE TOO CLOSELY. IN CASE IT IS NECESSARY TO CONFIRM LASER BEAM EMISSION, BE SURE TO OBSERVE FROM A DISTANCE OF MORE THAN 30cm FROM THE SURFACE OF THE OBJECTIVE LENS ON THE OPTICAL PICK-UP BLOCK.

LASER WARNING LABEL

The label shown below are affixed.

1. Warning lable

This label is located on the arm of mechanism.

(A)
DANGER —INVISIBLE LASER RADIATION WHEN OPEN AND INTERLOCK FAILED OR DEFEATED. AVOID DIRECT EXPOSURE TO BEAM
CAUTION —HAZARDOUS LASER AND ELECTROMAGNETIC RADIATION WHEN OPEN AND INTERLOCK DEFEATED.
ATTENTION —RAYONNEMENT LASER ET ELECTROMAGNETIQUE DANGEREUX SI OUVERT AVEC L'ECLENCHEMENT DE SECURITE ANNULE.

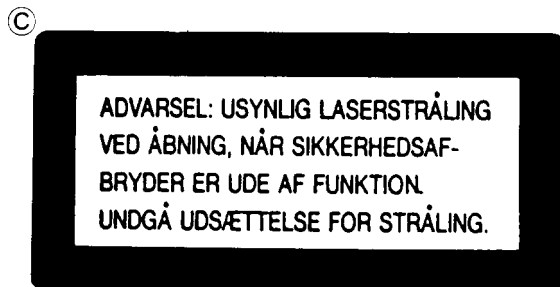
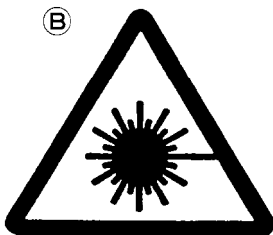

- (A)** : Danger label
- (B)** : Except 120V model
- (C)** : Except 120V model

Laser Diode Properties

- Material: GaAS/GaAlAs
- Wavelength: 780nm
- Emission Duration: continuous
- Laser output: max. 0.5mW*

*This output is the value measured at a distance about 1.8mm from the objective lens surface on the Optical Pick-up Block.

2. Certification label (120V model)

This label is located on the back panel.

PRODUCT IS CERTIFIED BY THE MANUFACTURER TO COMPLY WITH DHHS RULES 21 CFR SUBCHAPTER J APPLICABLE AT THE DATE OF MANUFACTURE

MANUFACTURED

3. Class 1 label (Except 120V model)

This label is located on the back panel.

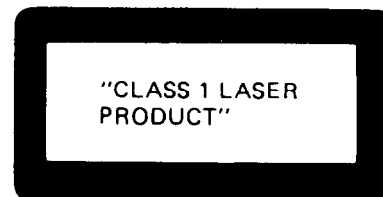

ADVARSEL

Denne mærkning er anbragt på apparatets højre side og indikerer, at apparatet arbejder med laserstråler af klasse 1, hvilket betyder, at der anvendes laserstråler af svageste klasse, og at man ikke på apparatets yderside kan blive udsat for utilladelig kraftig stråling.

APPARATET BØR KUN ÅBNES AF FAGFOLK MED SÆRLIGT KENDSKAB TIL APPARATER MED LASERSTRÅLER!

Indvendigt i apparatet er anbragt den her gengivne advarselmærkning, som advarer imod at foretage sådanne indgreb i apparatet, at man kan komme til at udsætte sig for laserstråling.

VAROITUS! Laitte sisältää laserdiodin, joka lähettää (näkyväntöntä) silmille vaarallista lasersäteilyä.

MECHANISM-EXPLODED VIEW

PICKUP UNIT-EXPLODED VIEW

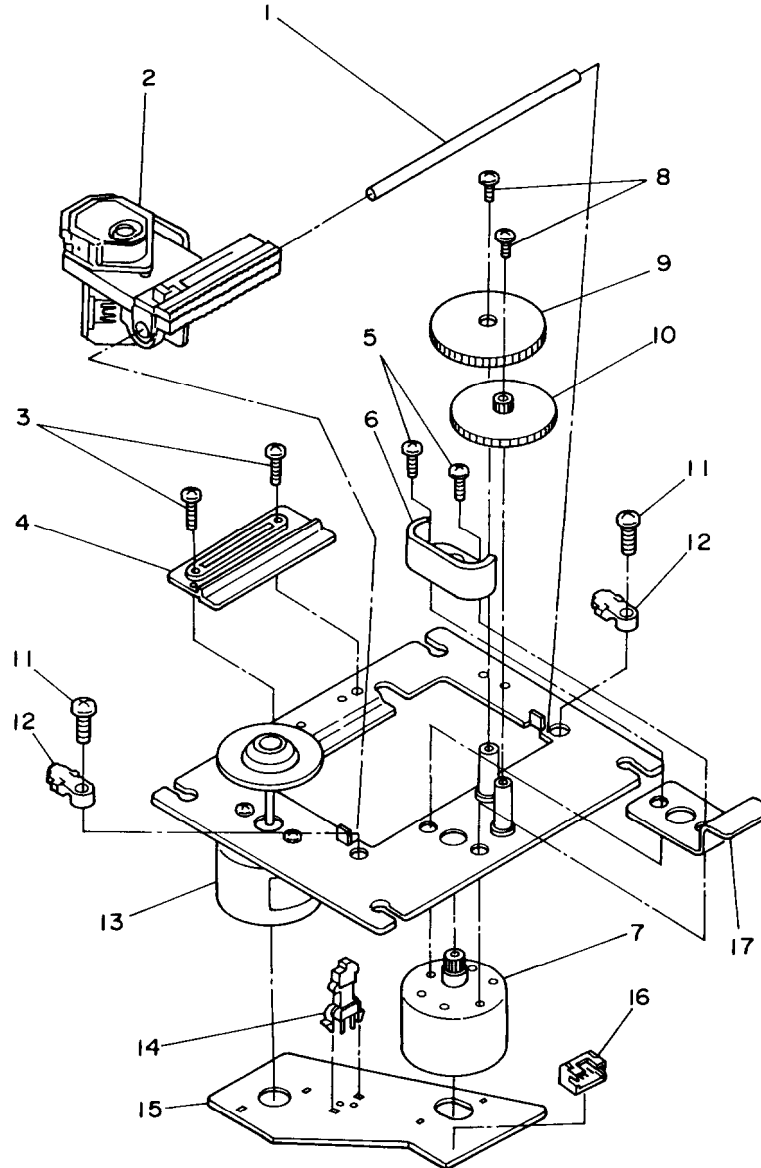

PARTS LIST

REF. NO.	PART NO.	DESCRIPTION	REF. NO.	PART NO.	DESCRIPTION
1	24506900	Shaft,slide	10	24506904	Wheel B
2	24110005	KSS-150A,Optical pickup	11	801427	+STP2.6x8,Special screw
3	801425	S2x5,Special screw	12	24506905	Clamp,shaft
4	24506901	Holder,slide	13	24502253	Spindle motor ass'y
5	82112005	+P2x5,Pan head screw	14	25065377	NLF-12018,Leafswitch
6	24506902	Cover,gear	15	24505270	Motor pc board
7	24502262	Motor	16	25050396	NSCT-4P223,Socket
8	801426	M1.7x3,Special screw	17	24506906	Stopper
9	24506903	Wheel A			

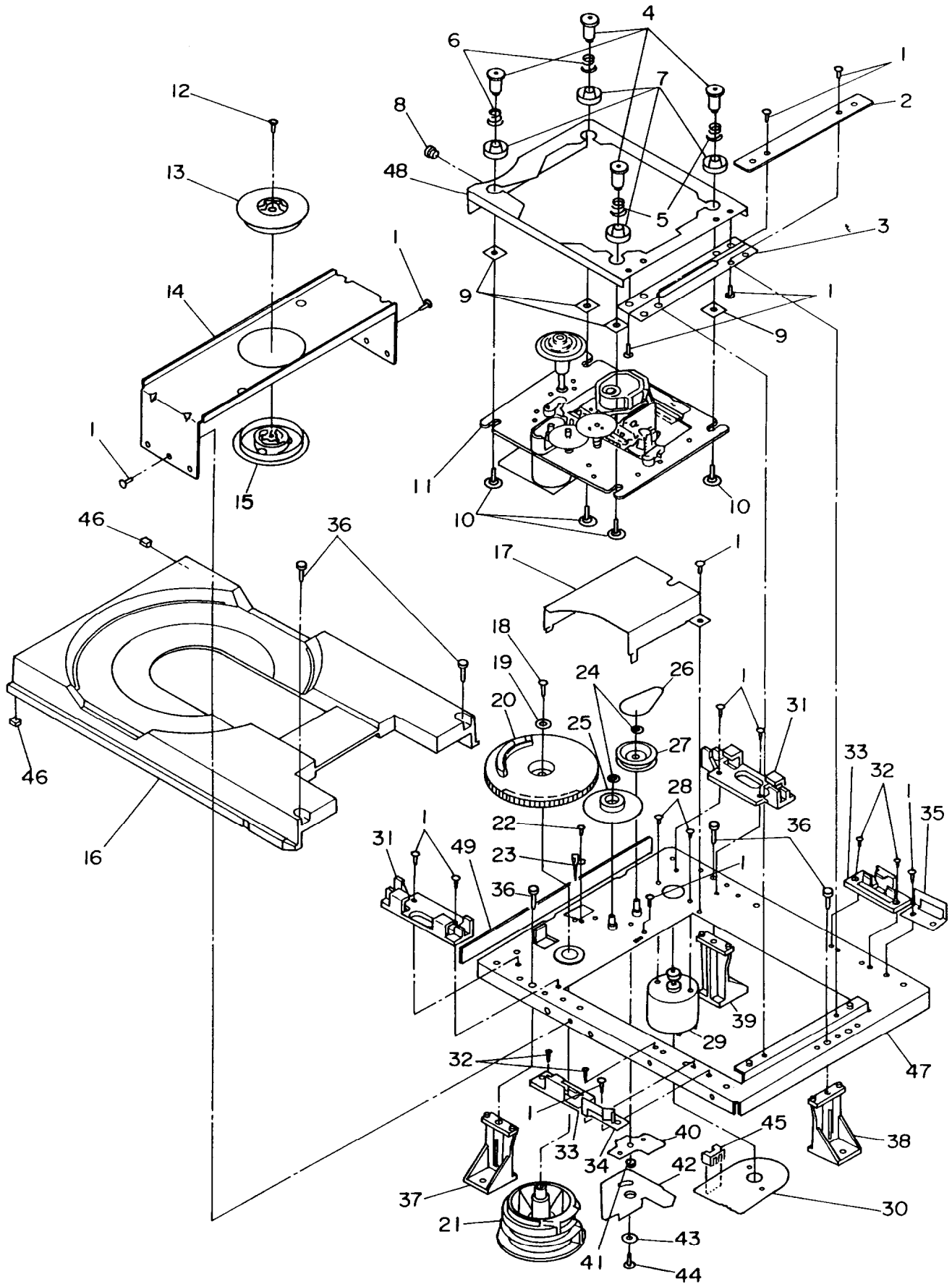

PARTS LIST

REF. NO.	PART NO.	DESCRIPTION
1	834126069	2.6TTS+6C,Self-tapping screw
2	24506864	Holder,hinge
3	24506865	Hinge
4	24506866	Shaft
5	27180441	Conical coil spring B
6	27180442	Conical coil spring A
7	24509401	Insulator C
8	24506870	Roller
9	24506871	Plate
10	801424	Screw with washer
11	24506873	KSM150ACM,Pickup unit
12	838426068	2.6TTB+6B(BC),Self-tapping screw
13	24506875	Magnet ass'y
14	24506876	Chassis,chucking
15	24506877	Pulley,chucking
16	24506878	Tray
17	24506879	Cover,gear
18	838426108	2.6TTB+10B(BC),Self-tapping screw
19	8761301008	W3x10F,Washer
20	24506882	Gear,drive
21	24506883	Cam,control
22	834120049	2TTS+4C,Self-tapping screw
23	25065374	Leafswitch
24	870144	Washer
25	27301227	Gear,middle
26	24602507	Belt
27	24506884	Pulley,loading
28	838426038	2.6TTB+3C(BC),Self-tapping screw
29	24506886	Motor
30	24505269	Motor pc board
31	27301228	Holder,tray,front
32	833120047	M2x4,Self-tapping screw
33	27301230	Holder,tray,rear
34	24506887	Guide,tray,right
35	24506888	Guide,tray,left
36	838430108	3TTB+10B(BC),Self-tapping screw
37	24506889	Boss,mount,right (for transport)
38	24506890	Boss,mount,back (for transport)
39	24506891	Boss,mount,left (for transport)
40	24506892	Plate,ring
41	24506893	Boss
42	24506894	Link,stopper
43	24506895	Spacer
44	83112608	2.6TTW+8S,Self-tapping screw
45	25050393	NCNT-5220,Connector
46	24506897	Damper
47	27301224	Chassis,main
48	24506898	Chassis,sub
49	28140980	Adhesive tape,front

REMOVEMENT OF DISC TRAY

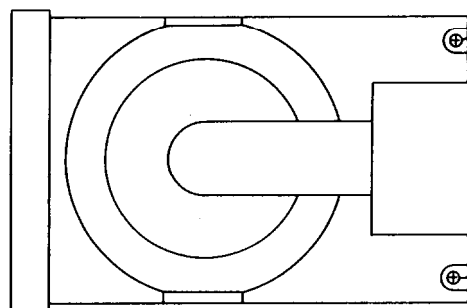

Screw for stopper

- 1.Loosen the screw for stopper until the head of screw and tray are the same height.
- 2.Turn POWER switch to on.
- 3.Press OPEN/CLOSE button to open the tray.
- 4.Turn POWER switch to off.
- 5.Remove the tray.

Screw for stopper

CHASSIS-EXPLODED VIEW

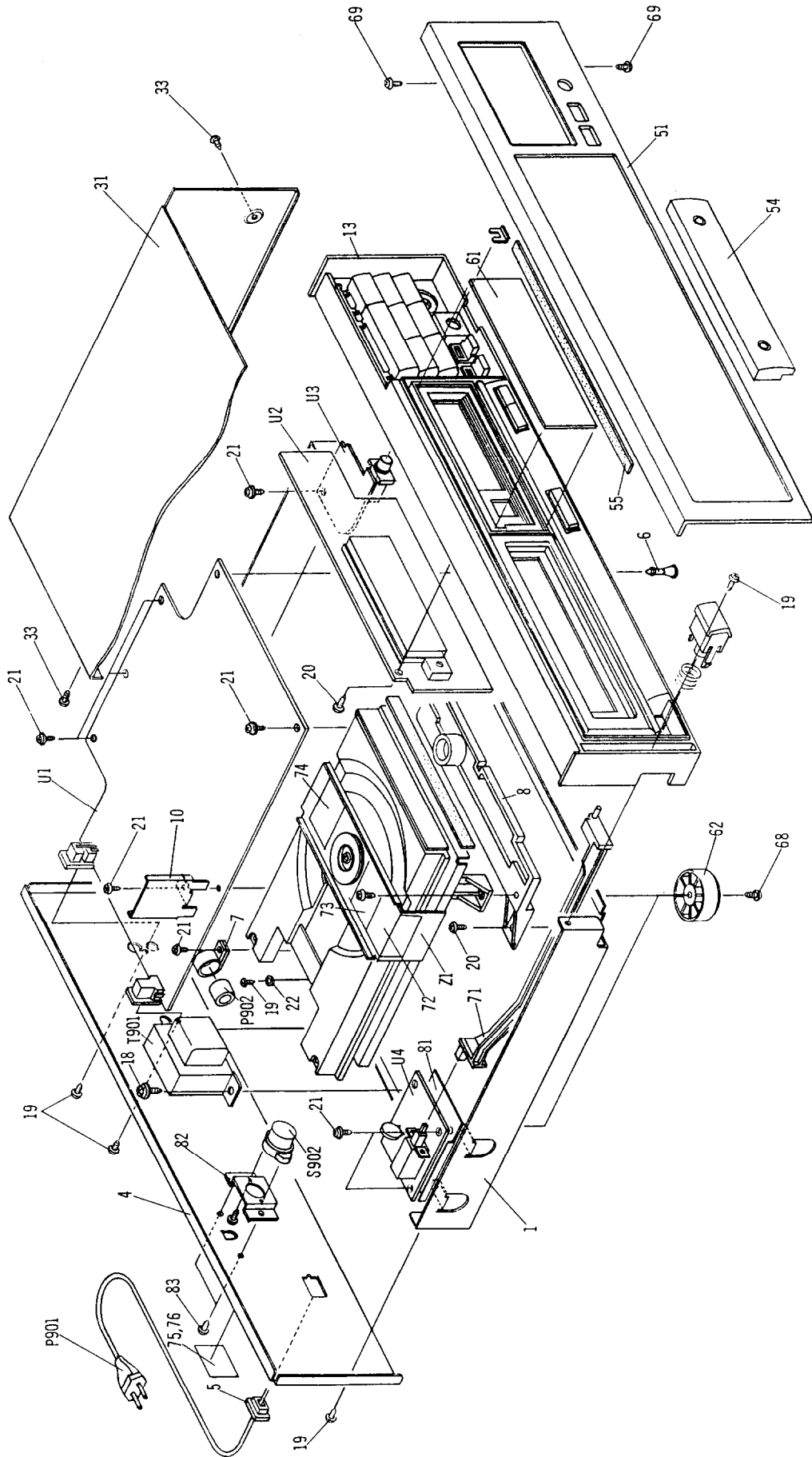

PARTS LIST

REF.NO.	PART NO.	DESCRIPTION	REF. NO.	PART NO.	DESCRIPTION
1	27100207B	Chassis	P902	230907	TR-16-8-16, Core
4	27121329	Back panel <D>	S1	2000951	NSAS-8P903, Socket (Red), Pickup
	27121329-1	Back panel <G>	S2	2000952	NSAS-8P904, Socket (White), Pickup
	27121329-3	Back panel <W>	S3	2002390810	NSAS-8P0120, Socket, Motor
	27121329-4	Back panel <QA/QB>	S4	2002391020	NSAS-10P0119, Socket, Motor
5	△ 27300750	Bushing (Strainrelief)	S902	△ 25065168	HXW0131-01-060, Voltage selector switch <W>
6	27190524	Holder	T901	△ 2300291 or △ 2300553	NPT-991D or NPT-1072D, Power transformer <D>
7	27273125A	Joint, power		△ 2300292 or △ 2300554	NPT-991G or NPT-1072G, Power transformer <G>
8	27190753A	Holder, mechanism		△ 2300294 or △ 2300555	NPT-991ADGQ or NPT-1072ADGQ, Power transformer <W>
10	27141397	Bracket S		△ 2300293 or △ 2300556	NPT-991Q or NPT-1072Q, Power transformer <OA/QB>
13	27110551C	Front bracket	U1	1H107535-1	NAAR-3835-1, Main circuit pc board ass'y <D>
18	830440089	4TTC+8C (BC), Self-tapping screw	U2	1H107535-1A	NAAR-3835-1a, Main circuit pc board ass'y <G/W/QA/QB>
19	834430088	3TTS+8B (BC), Self-tapping screw	U3	1H107537-1	NAAF-3837-1, Headphone amplifier pc board ass'y <D>
20	833430080	3TTP+8P (BC), Self-tapping screw	U4	1H107537-1A	NAAF-3837-1a, Headphone amplifier pc board ass'y <G/W/QA/QB>
21	831130088	3TTW+8B, Self-tapping screw	Z1	24506792	NAPS-3838-1, Power supply pc board ass'y
22	87643010	W3×10F (BC), Washer		260208	NCD-110S, CD mechanism ass'y Binder
31	28184452	Top cover			
33	834430088	3TTS+8B (BC), Self-tapping screw			
51	1H107121	Front panel ass'y			
54	27211174	Tray panel			
55	28140546	Cushion			
61	28191551	Clear plate			
62	27175153-1	Leg			
68	833430088	3TTS+8B (BC), Self-tapping screw			
69	833430080	3TTP+8P (BC), Self-tapping screw			
71	260221	NK-10N, Clamp			
72	29360807	Label, DANGER			
73	29361218	Label, LASER <G/W/QA/QB>			
74	29360811A	Label <G/QA/QB>			
75	29360840	Label <D>			
76	29360687	Label, CLASS 1 <G/W/QA/QB>			
81	28175175	Insulator plate <G/W/QA/QB>			
82	27141090A	Bracket U <W>			
83	834430088	3TTS+8B (BC), Self-tapping screw <W>			
P901	△ 253099C	AS-UC-3, Power supply cord <D>			
	△ 253148 or △ 253150	AS-CEE 250V 2.5A Power supply cord <G/W>			
	△ 253118	AS-SAA, Power supply cord <QA>			
	△ 728328	Power supply cord <QB>			

NOTE: <D>: Only 120V model
 <G>: Only 220V model
 <W>: Only Worldwide model
 <QA>: Only Australian model
 <QB>: Only British model

NOTE: THE COMPONENTS IDENTIFIED BY MARK
 △ ARE CRITICAL FOR RISK OF FIRE AND
 ELECTRIC SHOCK. REPLACE ONLY WITH
 PART NUMBER SPECIFIED.

IC BLOCK DIAGRAM AND DESCRIPTIONS

Q102

CX41081S (RF Amplifier)

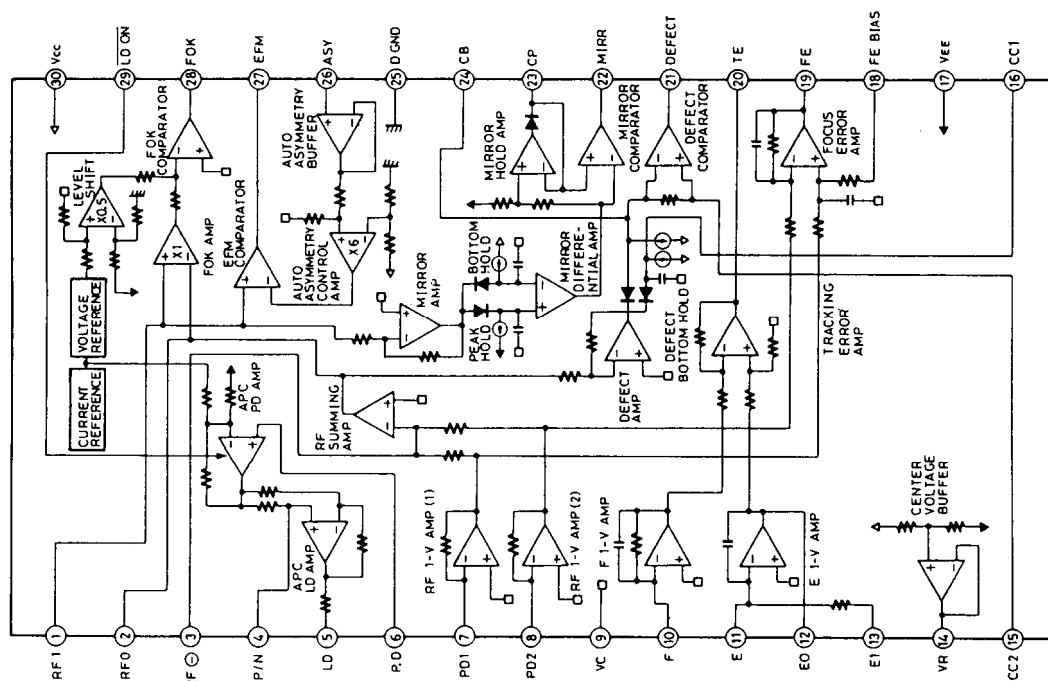

Pin No.	Symbol	Function	Pin No.	Symbol	Function
1	RF1	Input terminal of output signal of RF summing amplifier via the coupling capacitor	16	CC1	Defect bottom hold output terminal
2	RFO	Output terminal of RF summing amplifier	17	VEE	Negative power supply terminal
3	RF-	Input terminal of RF summing amplifier feedback	18	FE BIAS	Non-inversion bias terminal of focus error amplifier CMR adjustment of focus error amplifier
4	P/N	Switching terminal of P-SUB/N-SUB of LD (laser diode)	19	FE	Output terminal of focus error amplifier
5	LD	Output terminal of APC LD amplifier	20	TE	Output terminal of tracking error amplifier
6	PD	Input terminal of APC PD (Pin diode) amplifier	21	DEFECT	Output terminal of defect comparator
7	PD1	Inversion input terminal of RF I-V amplifier (1) Connect to A+C of PIN diodes.	22	MIRR	Output terminal of mirror comparator
8	PD2	Inversion input terminal of RF I-V amplifier (2) Connect to B+D of PIN diodes.	23	CP	Connection terminal of capacitor for mirror hold Non-inversion input of mirror comparator
9	VC	Connect to GND.	24	CB	Connection terminal of capacitor for defect bottom hold
10	F	Inversion input terminal of F I-V amplifier Connect to F of PIN diode.	25	DGND	Connect to GND
11	E	Inversion input terminal of E I-V amplifier Connect to E of PIN diode.	26	ASY	Auto asymmetry control input terminal
12	E0	Output terminal of E I-V amplifier	27	EFM	Output terminal of EFM comparator
13	E1	Feedback input terminal of E I-V amplifier Gain adjustment of E I-V amplifier	28	FOK	Output terminal of FOK comparator
14	VR	DC voltage output terminal of $(V_{CC} + V_{EE})/2$	29	LD ON	ON/OFF switching terminal of laser diode
15	CC2	Input terminal from defect bottom hold output signal via the coupling capacitor	30	Vcc	Positive power supply

Q104
CXA1082BS (Servo Signal Processor)

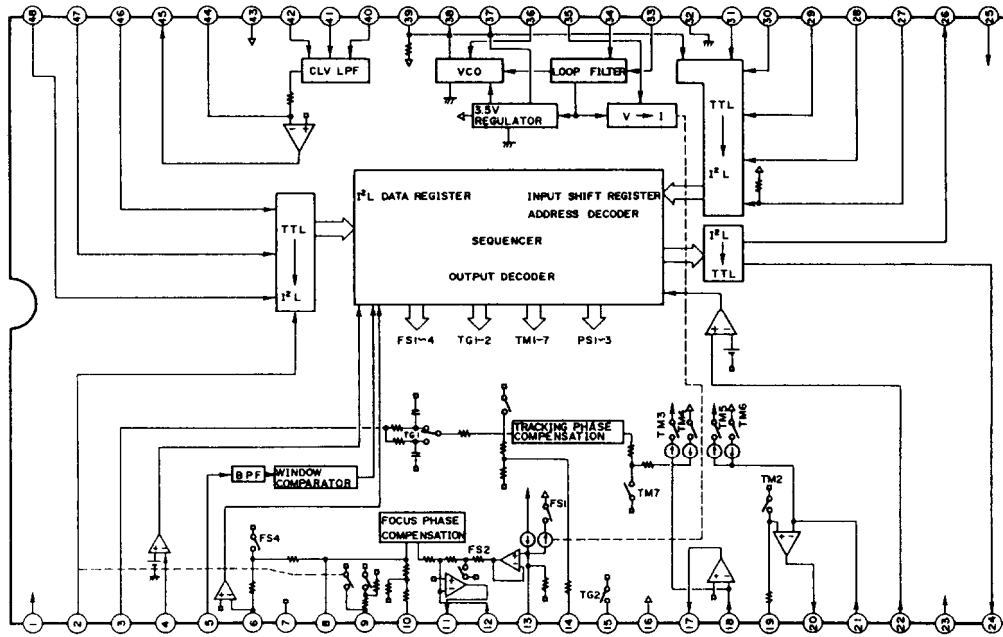

Pin No.	Symbol	Function	Pin No.	Symbol	Function
2	DECT	Defect signal input terminal.	26	C. OUT	Signal output terminal for count of track numbers.
3	TE	Tracking error signal input terminal.	27	DIRC	Use when jumps one track.
4	TZC	Tracking zero cross comparator input terminal.	28	XRST	Reset input terminal. Reset at the low level.
5	ATSC	Window comparator input terminal for ATSC detection.	29	DATA	Serial data input terminal from microprocessor.
6	FE	Focus error signal input terminal.	30	XLT	Latch input terminal from microprocessor.
8	FGD	Insert the capacitor between this terminal and pin 9 when drop the high frequency gain of focus servo.	31	CLK	Clock input terminal serial data transmitter from microprocessor.
9	FS3	Switching terminal of high frequency gain of focus servo.	33	BW	Time constant terminal of loop filter.
10	FLB	Time constant switching terminal when raise the low frequency gain of focus servo.	34	PDI	Input terminal of phase comparator output PDO.
11	FEO	Focus drive output terminal.	35	ISET	Flow the current to decide the focus search, track jump, and kick height.
12	FE-	Inversion input terminal of focus amplifier.	36	VCOF	VCO free run frequency is proportion to resistor value between pins 31 and 37.
13	SRCH	Time constant terminal to make the focus search waveform.	38	C864	VCO (8.64MHz) output terminal.
14	TGU	Time constant terminal for high frequency gain switching of tracking.	39	LOCK	Sled motor run away prevention circuit is operated at low level.
15	TG2	Time constant terminal for high frequency gain switching of tracking.	40	MDP	Connection terminal to terminal MDP of CXD1130Q.
17	TAO	Tracking drive output terminal.	41	MON	Connection terminal to terminal MON of CXD1130Q.
18	TA-	Inversion input terminal of tracking amplifier.	42	FSW	LPF time constant terminal of CLV servo error signal.
19	SL+	Non-inversion input terminal of sled amplifier.	44	SPDL-	Inversion input terminal of spindle drive amplifier.
20	SLO	Sled drive output terminal.	45	SPDLO	Spindle drive output terminal.
21	SL-	Inversion input terminal of sled amplifier.	46	WDCK	Clock input terminal. (88.2kHz)
22	SSTOP	Limit switch ON/OFF detector signal terminal for disc innermost position detector.	47	FOK	Focus OK input terminal.
23	FSET	Terminal for peak of phase compensation of tracking and f ₀ setting LPF.	48	MIRR	Mirror signal input terminal.
24	SENS	FZC, AS, TZC, SSTOP and etc. signals are output by the command from microprocessor.			

Q108
CXD1130Q (Digital Signal Processor)

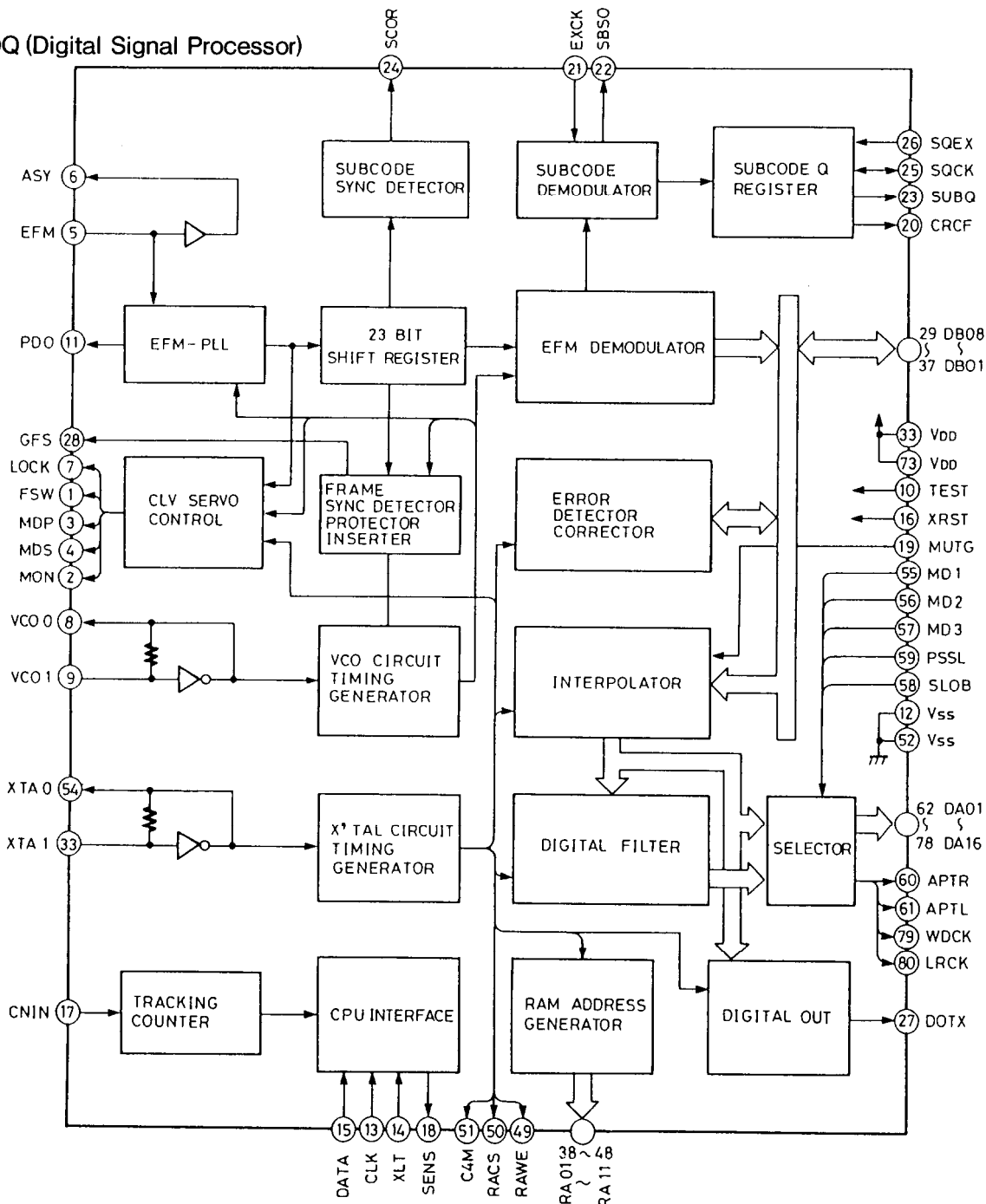

Q109
CXK5816SPS-15L etc. (16k RAM)

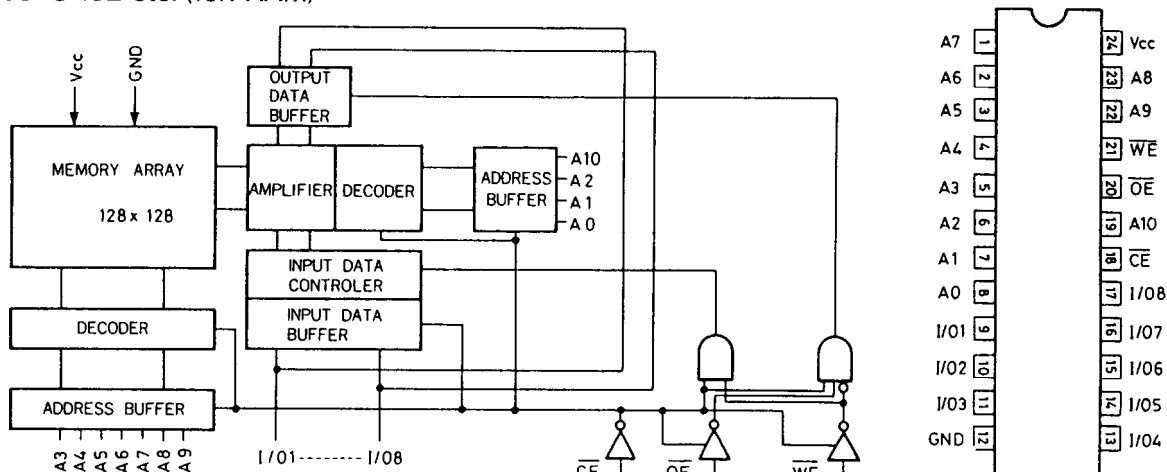

Pin No.	Symbol	Function	Pin No.	Symbol	Function
1	FSW	Time constant switching output terminal of output filter of spindle motor	49	RAWE	Write enable signal output to external RAM
2	MON	ON/OFF control output terminal of spindle motor	50	RACS	Chip selector signal output to external RAM
			51	C4M	Divider output of crystal. f=4.2336MHz
3	MDP	Drive output terminal of spindle motor. Rough control when mode CLV-S and phase control when mode CLV-P	52	Vss	Ground
			53	XTAI	Input terminal of crystal oscillator
4	MDS	Drive output terminal of spindle motor. Speed control when mode CLV-P	54	XTAO	Output terminal of crystal oscillator
			55	MD1 ? MD3	Mode switching input terminals
5	EFM	EFM signal input terminal from RF amplifier	57		
6	ASY	Output terminal to control the slice level of EFM signal	58	SLOB	Code switching input of audio data output.
7	LOCK	GFS sampling terminal	59	PSSL	Mode switching input of audio data output. Serial output at low level. Parallel output at high level
8	VCOO	VCO output terminal. 8.6436MHz when lock to EFM signal			
9	VCOI	VCO input terminal	60	APTR	Control output for aperture correction. High level when Rch.
10	TEST	0V	61	APTL	Control output for aperture correction. High level when Lch.
11	PDO	Phase comparator output terminal of EFM signal and VCO/2	62	DA01	DA01 (LSB of parallel sound output) output when PSSL = H. C1F1 output when PSSL = L
12	Vss	Ground	63	DA02	DA02 output when PSSL = H. C1F2 output when PSSL = L.
13	CLK	Serial data transmitter clock input terminal from microcomputer	64	DA03	DA03 output when PSSL = H. C2F1 output when PSSL = L.
14	XLT	Latch input terminal from microcomputer	65	DA04	DA04 output when PSSL = H. C2F2 output when PSSL = L.
15	DATA	Serial data input terminal from microcomputer	66	DA05	DA05 output when PSSL = H. C2FL output when PSSL = L.
16	XRST	System rest input terminal. Reset at low level.	67	DA06	DA06 output when PSSL = H. C2PO output when PSSL = L.
17	CNIN	Tracking pulse input terminal	68	DA07	DA07 output when PSSL = H. RFCK output when PSSL = L.
18	SENS	Inner condition output terminal correspond to address	69	DA08	DA08 output when PSSL = H. WFCK output when PSSL = L.
19	MUTG	Muting input terminal	70	DA09	DA09 output when PSSL = H. PLCK output when PSSL = L.
20	CRCF	CRC check output terminal of subcode Q			
21	EXCK	Clock input terminal for serial output of subcode	71	DA10	DA10 output when PSSL = H. UGFS output when PSSL = L.
22	SBSO	Serial output terminal of subcode	72	DA11	DA11 output when PSSL = H. GTOP output when PSSL = L.
23	SUBQ	Subcode Q output terminal			
24	SCOR	Subcode sink S0 + S1 output terminal	73	VDD	Power supply (5V)
25	SQCK	Clock terminal to read the subcode Q			
26	SQEX	Selector input terminal of SQCK	74	DA12	DA12 output when PSSL = H. RAOV output when PSSL = L.
27	DOTX	Digital output terminal	75	DA13	DA13 output when PSSL = H. C4LR output when PSSL = L.
28	GFS	Indicator output of lock condition of frame sync	76	DA14	DA14 output when PSSL = H. C210 output when PSSL = L.
29	DB08 ? DB05	Data terminals of external RAM			
30			77	DA15	DA15 output when PSSL = H. C210 output when PSSL = L.
31					
32			78	DA16	DA16 (MSB of parallel sound output) output when PSSL = H. DATA output when PSSL = L
33	VDD	+5V			
34	DB04 ? DB01	Data terminals of external RAM	79	WDCK	Strobe signal output. 176.4kHz when DF is on. 88.2kHz when DF is off.
35			80	LRCK	Strobe signal output. 88.2kHz when DF is on. 44.1kHz when DF is off.
36					
37					
38	RA01 ? RA11	Address output terminals of external RAM			
39					
40					
41					
42					
43					
44					
45					
46					
47					
48					

DX-1400

Q114
CXP50112-114Q (Microprocessor)

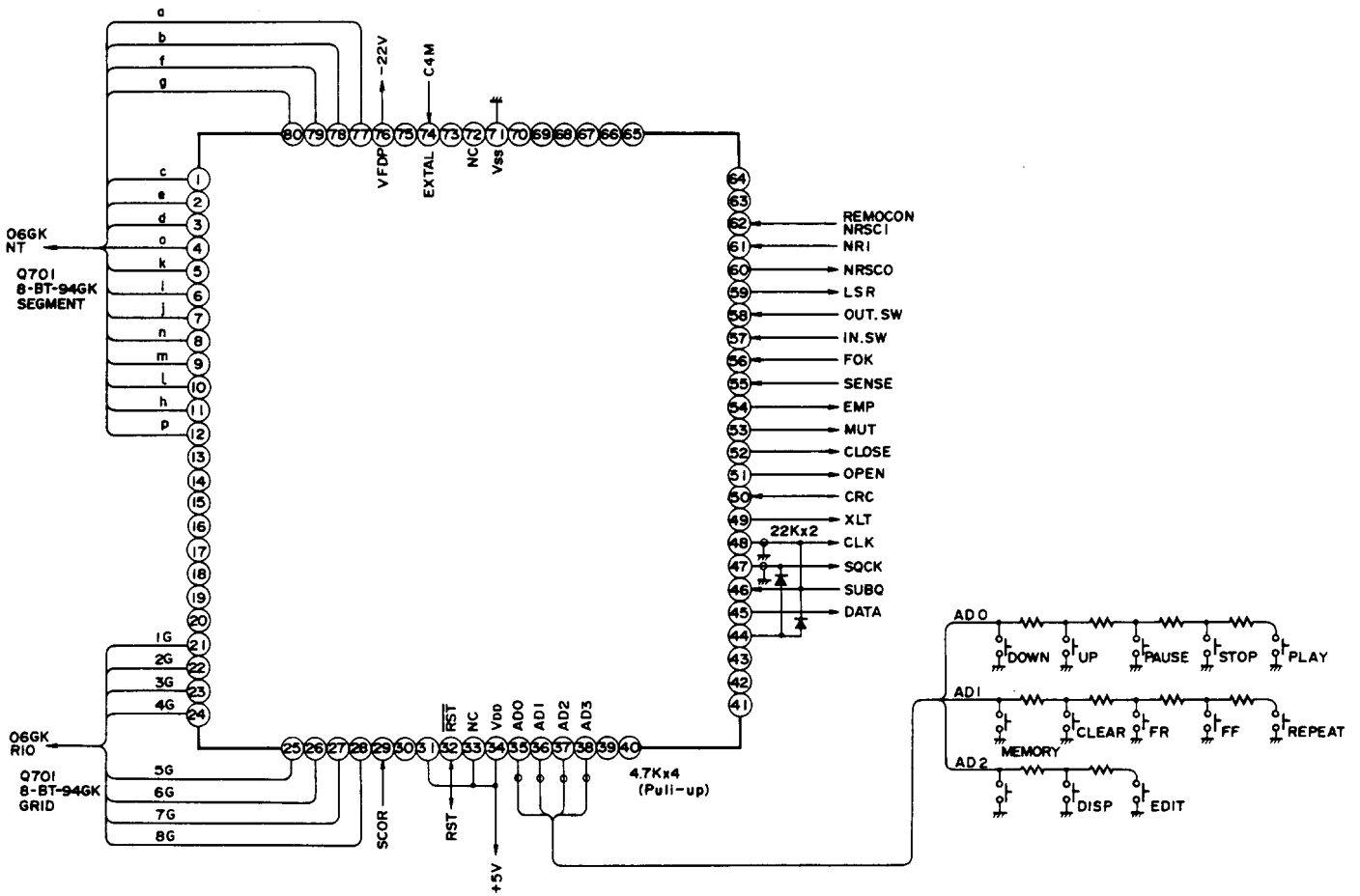

Q105
LA6510 (Motor Drive)

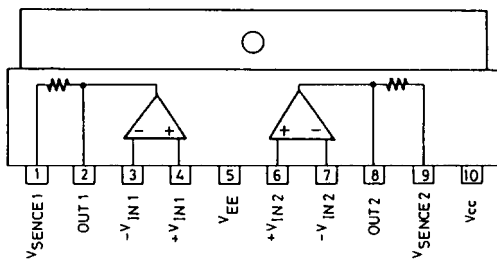

Q106
STA341M-L (Transistor Array)

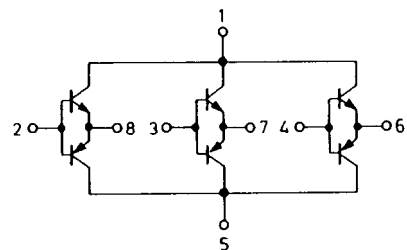

Pin No.	Symbol	I/O	Function
1~12	c~e,h~p	0	Fluorescent tube segment drive output terminals.
21~28	1G~8G	0	Fluorescent tube grid drive output terminals.
29	SCOR	I	Subcode SQ+SI input terminal.
32	RST	I	Reset input terminal.Reset at "L".
34	VDD		Power supply terminal.Connect to 5V.
35~38	AD0~AD3	I	AD input terminals.Connect the operation keies.
45	DATA	0	Serial data signal output terminal.
46	SUBQ	I	Subcode Q input terminal.
47	SQCK	I/O	Subcode Q read clock.
48	CLK	0	Serial data transmission clock output terminal.
49	XLT	0	Command execution output terminal.
50	CRC	I	Subcode check input terminal.
51	OPEN	0	Tray motor control output terminal.Tray opens at "H".
52	CLOSE	0	Tray motor control output terminal.Tray closes at "H".
53	MUT	0	Muting ON/OFF output terminal.Muting switch turns on at "H".
54	EMP	0	Emphasis ON/OF output terminal.Emphasis switch turns on at "H".
55	SENSE	I	Interface of signal processor and microprocessor ICs.
56	FOK	I	Focus OK input terminal.Focus OK at "H".
57	IN SW	I	Tray close detection input terminal.
58	OUT SW	I	Tray open detection input terminal.
59	LSR	0	Optical pickup control output terminal.Optical pickup turns on at "L".
60	NRSCO	0	Remote control signal output terminal.
61	NRI	I	RI signal input terminal.
62	NRSI	I	Remote control signal input terminal.
74	C4M	I	System clock input terminal.(4.2336MHz)
76	VFDP		Power supply terminal.Connect to -22V.
77~80	a,b,f,g	0	Fluorescent tube segment drive output terminals.

Q115
M51943ASL (Rest IC)

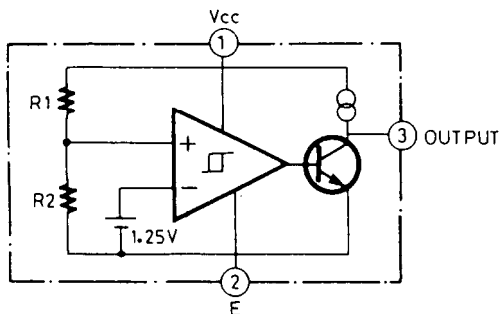

Q116

YM3433 (18 bits/8 times Oversampling Digital Filter)

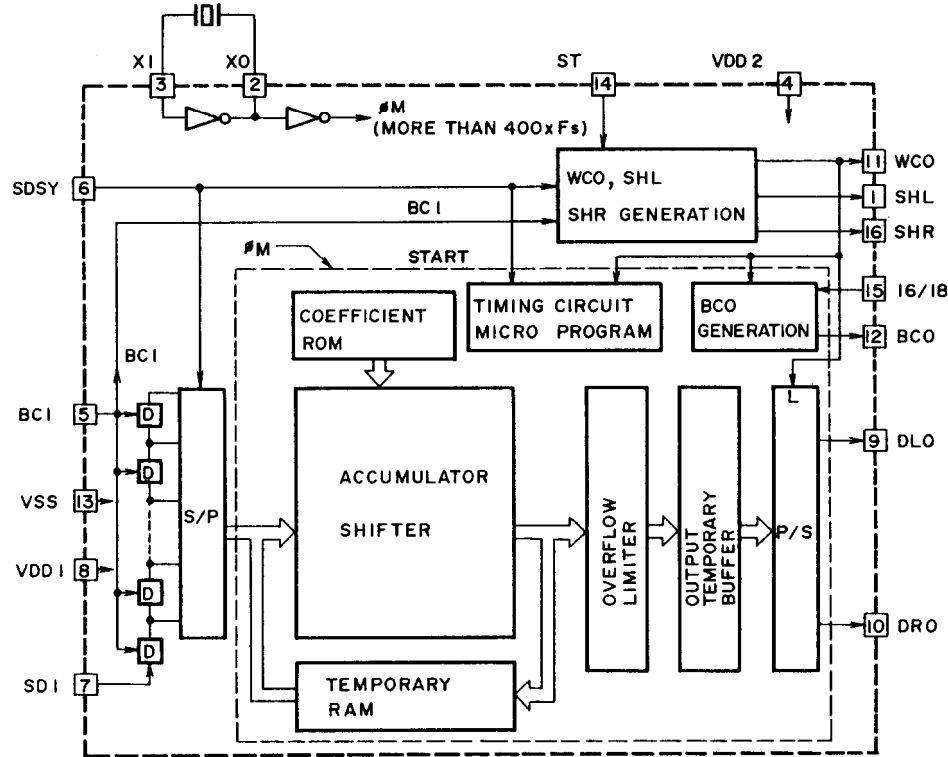

Pin No.	Terminal	Function
1	SHL	ST=L(1 DAC):L channel deglitch signal output. ST=H(2 DACs):L and R channels deglitch signal output. (Not used.)
2	XO	Connect the crystal oscillator for the system clock to these terminals.
3	XI	
4	VDD2	Power supply terminal for crystal oscillator and deglitch signal system.
5	BCI	Bit clock input terminal of input data.
6	SDSY	Clock input terminal to show the input timing and L/R channels partitioned of input data.
7	SDI	Data input terminal.
8	VDD1	Power supply terminal.(Connect to 5V.)
9	DLO	ST=L(1 DAC):L and R channels data output terminal. ST=H(2 DAC):L channel data output terminal.
10	DRO	R channel data output terminal.
11	WCO	Word clock output terminal for output data DLO/DRO.
12	BCO	Bit clock output terminal for output data DLO/DRO.
13	VSS	Ground terminal.
14	ST	1 DAC/2 DAC selection terminal.(1 DAC at low level and 2 DAC at high level.)
15	16/18	Bit number selection terminal.(16 bits at low level and 18 bits at high level.)
16	SHR	1 DAC(ST=L):R channel deglitch signal output.(Not used.)

Q117, Q118
PCM61P (DA Converter)

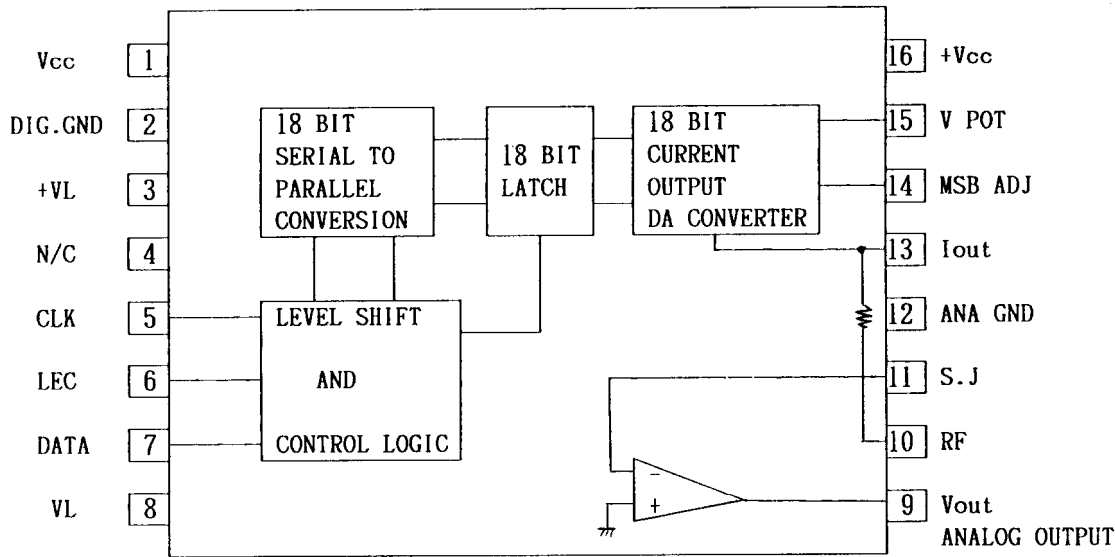

Pin No.	Symbol	Function	Pin No.	Symbol	Function
1	-Vcc	Analog negative power supply	16	+Vcc	Analog positive power supply
2	DIG GND	Digital ground	15	VPOT	Potential meter output
3	+VL	Logic positive power supply	14	MSB ADJ	MSB adjustment terminal
4	NC	No connection	13	Iout	Current output
5	CK	Clock input	12	ANA GND	Analog ground
6	LEC	Latch enable control input	11	S.J	Summing junction (Operation amplifier input)
7	DATA	Data input	10	RF	Feedback resistor
8	-VL	Logic negative power supply	9	Vout	Voltage output (Analog output)

Q701
8-BT-94GK (Fluorescent Tube)

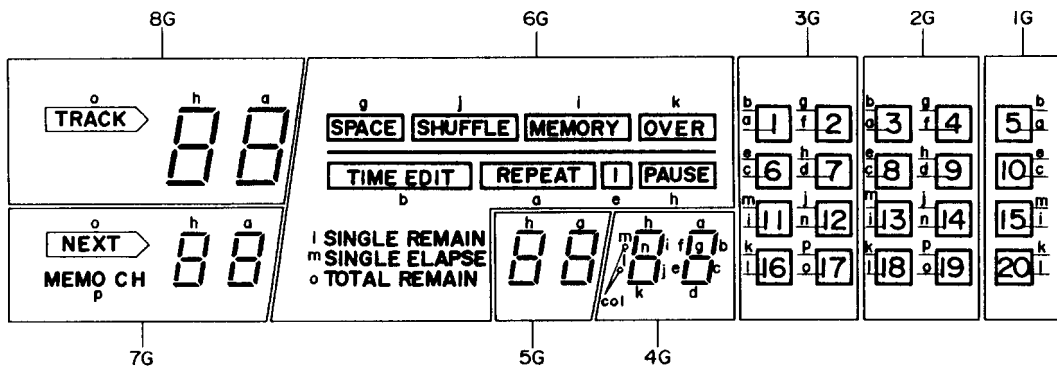

PIN NO.	1	2	3	4	5	6	7	8	9	10	11	12	13	14	15	16
CONNECTION	F1	F1	NP	8G	7G	6G	5G	4G	3G	2G	1G	q	p	h	i	NP
PIN NO.	17	18	19	20	21	22	23	24	25	26	27	28	29	30	31	32
CONNECTION	NP	NP	NP	NP	NP	NP	NP	m	n	j	l	k	o	d	e	c
PIN NO.	33	34	35	36	37	38	39	Note: NP.....No pin 1G~8G.....Grid								
CONNECTION	g	f	b	a	NP	F2	F2	F1, F2.....Filament								

ADJUSTMENT PROCEDURES

Instruments required

Dual trace oscilloscope, Frequency counter, AF oscillator, Test disc (SONY YEDS-18), AC voltmeter, Jitter meter, and Socket P4(Part no. 25050138)

1. VCO frequency adjustment

Connect the frequency counter to terminal P108.

Turn the power switch to ON.(No load the disc.)

Adjust R154 until the frequency counter reading becomes $4322 \pm 5\text{kHz}$.

After adjustment, disconnect the frequency counter.

2. Focus offset adjustment

Load the test disc YEDS-18 on the tray and play the track 2.

Connect the oscilloscope or jitter meter to terminal P106.

(Oscilloscope)

Adjust R110 until a clear trace of waveform pattern as shown photo 1 appear on the oscilloscope.

When the amount of jitter is broad, set R110 to mechanical center.

(Jitter meter)

Adjust R110 until the jitter meter reading becomes minimum.(Less than 10ns.)

After adjustment, disconnect the oscilloscope or jitter meter.

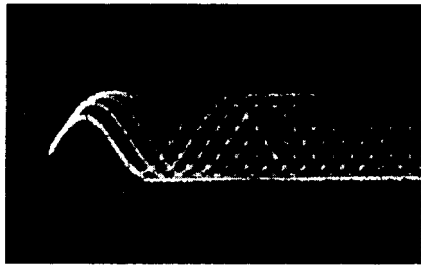
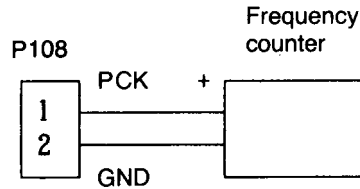
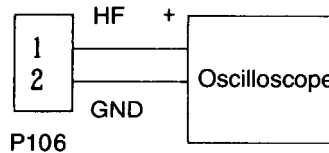
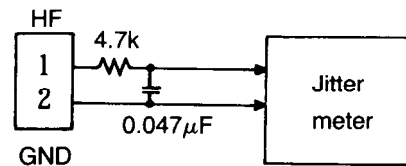

Photo 1



Oscilloscope range
Vertical : 0.5V/div.
Horizontal : 0.2 μs /div.
DC, Ground: Center



3. Tracking offset adjustment

Load the test disc YEDS-18 on the tray and play the track 2.

Turn R132 to minimum position.(Counter clockwise)

Connect the oscilloscope between pin 3 (TR) of P107 and pin 2 (GND) of P106.

Adjust R108 until the center of tracking error signal on the oscilloscope becomes GND level.

Turn R132 to the mechanical center.

After adjustment, disconnect the oscilloscope.

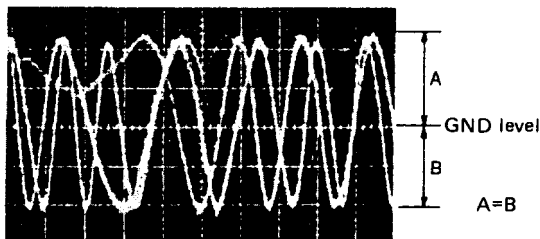
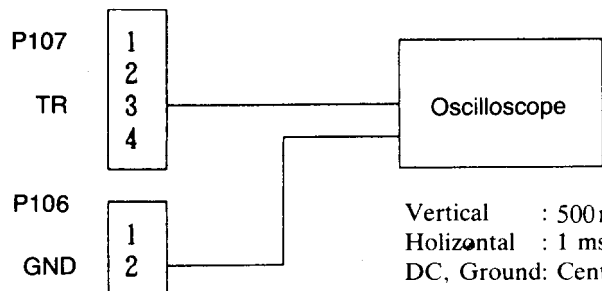
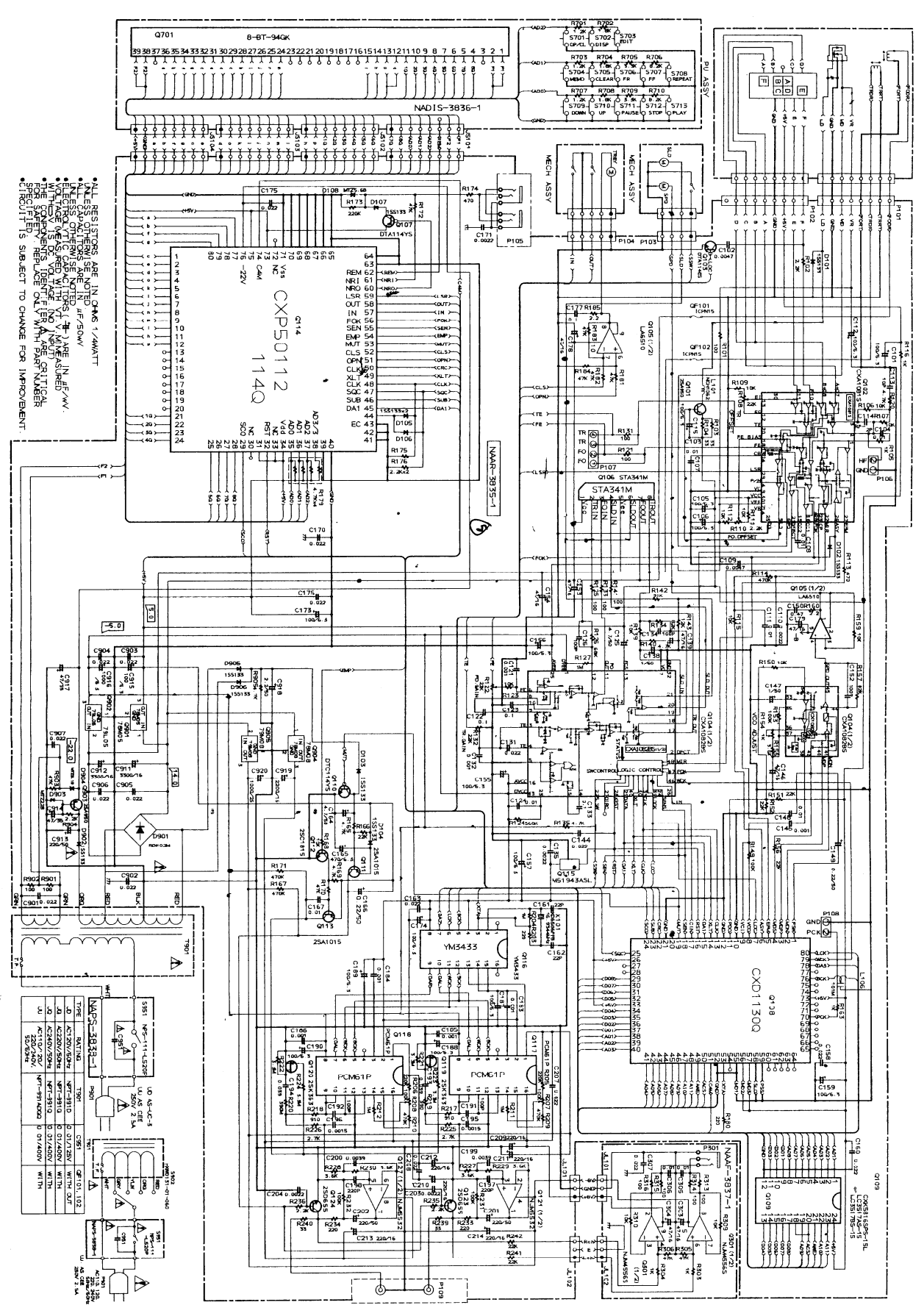

Photo 2



Vertical : 500mV/div.
Horizontal : 1 ms/div.
DC, Ground: Center

SCHEMATIC DIAGRAM



ALL RESISTORS ARE IN OHMS UNLESS NOTED OTHERWISE.
 CAPACITORS ARE IN P.F./SEC. UNLESS NOTED OTHERWISE.
 ELECTRICAL CHARACTERISTICS ARE AS SPECIFIED IN THE DATA SHEET.
 WITH A 5% TOLERANCE UNLESS OTHERWISE SPECIFIED.
 THE SUPPLY VOLTAGE IS 5V DC UNLESS OTHERWISE SPECIFIED.
 SPECIFICATIONS SUBJECT TO CHANGE FOR IMPROVEMENT.

4. Focus gain adjustment

Set the output of AF oscillator to 800Hz, 1~1.5Vp-p.

Play the track 2 of test disc.

Connect the oscilloscope and the AF oscillator as shown below.

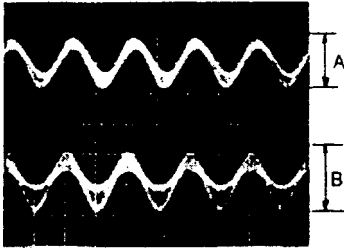
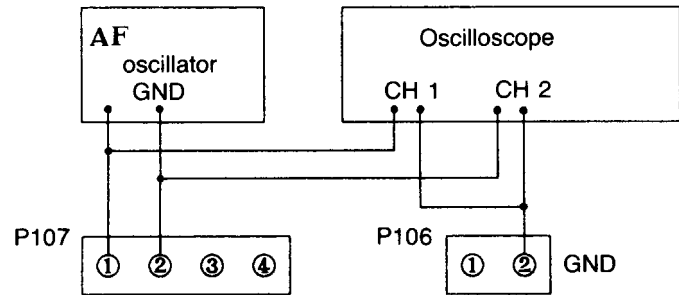

Photo 3



Vertical : 0.2V/div.
Horizontal: 0.5 ms/div.

Adjust R122 until 800Hz components of channels 1 and 2 on oscilloscope become same level.

After adjustment, disconnect the AF oscillator and the oscilloscope.

5. Tracking gain adjustment

Set the output of AF oscillator to 1.2kHz, 1~1.5Vp-p.

Play the track 2 of test disc.

Connect the oscilloscope and the AF oscillator as shown below.

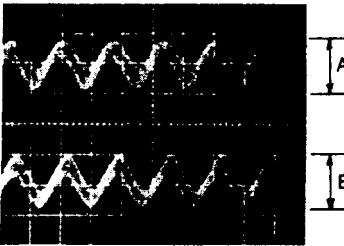
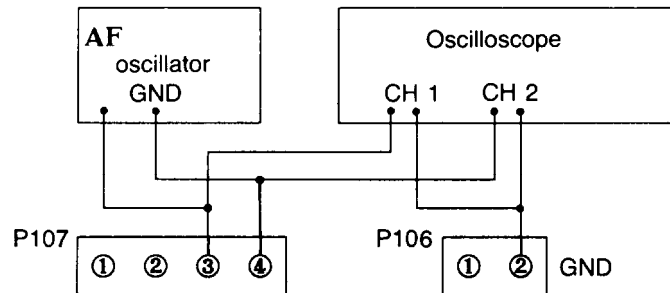

Photo 4



Vertical : 0.2V/div.
Horizontal: 0.5 ms/div.

Adjust R132 until 1.2kHz components of channels 1 and 2 on oscilloscope become same level.

After adjustment, disconnect the AF oscillator and the oscilloscope.

After adjustment, confirm that the center of tracking error signal becomes GND level.

6. Audio circuit adjustment

Connect the AC voltmeter to output terminal of left channel (right channel).

Load the test disc and play the track 2.

Next, play the track 17.

Adjust R207(R208) so that the output discrepancy between track 2 and track 17 is 60 ± 0.25 dB.

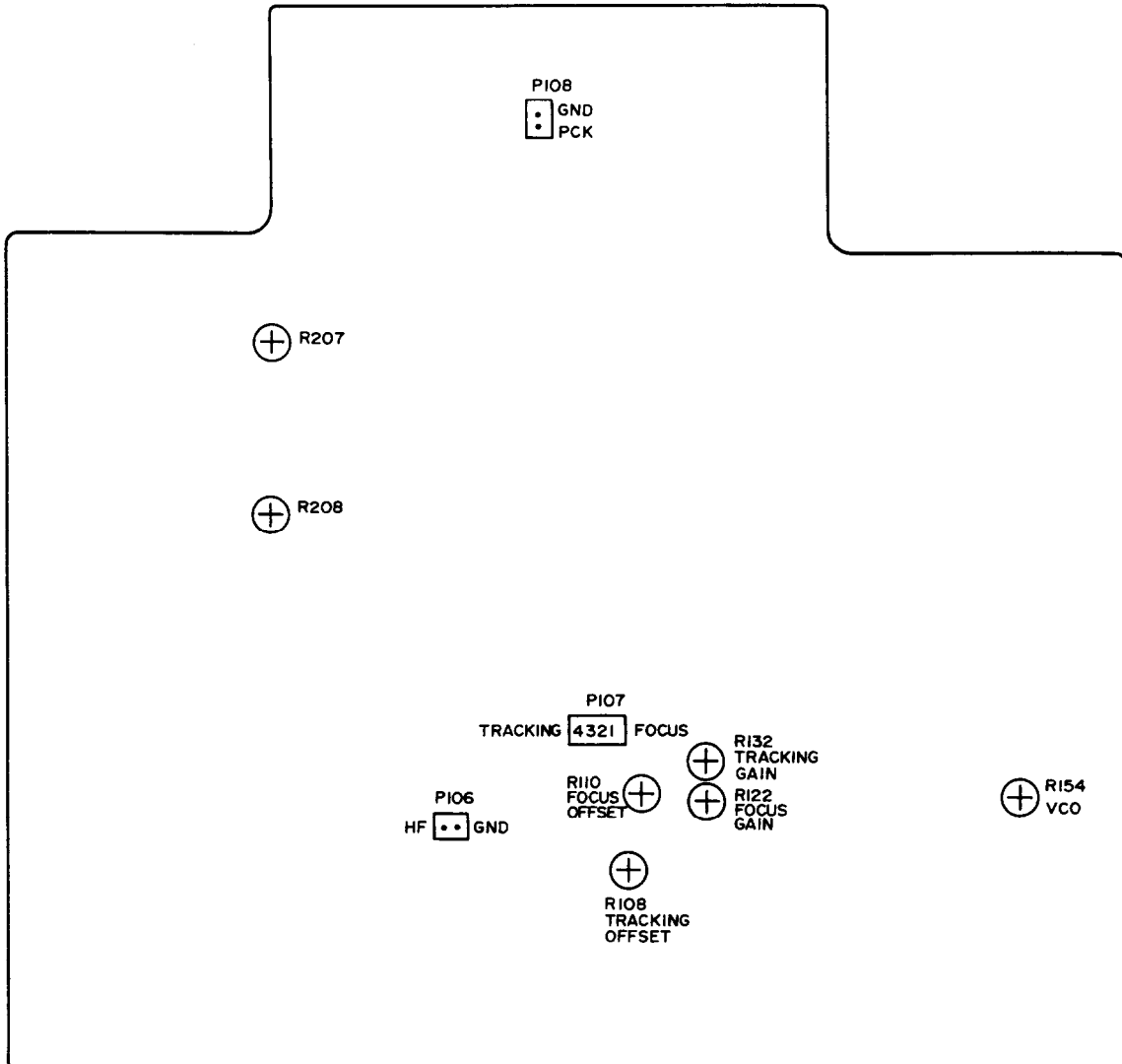

PARTS LIST

MAIN CIRCUIT PC BOARD(NAAR-3835-1/1A)

CIRCUIT NO.	PART NO.	DESCRIPTION
ICs		
Q102	22240180	CXA1081S
Q104	22240263	CXA1082BS
Q105	<u>22240034</u>	LA6510
Q106	22240168	STA341M-L
Q108	22240095	CXD1130Q
Q109	22240178, 22240234 or 22240118	CXK5816SPS-15L, LC3517BS-15 or LC3517AS-15
Q114	22240320	CXP50112-114Q
Q115	22240018	M51943ASL
Q116	22240321	YM3433
Q117, Q118	22240324	PCM61P
Q121	222902	NJM5532D-D
Q901	222780055MIT	M5F78M05L
Q902	222790053	79L05
Q904	222780085MIT	M5F78M08
Q905	222790085MIT	M5F79M08
Transistors		
Q101, Q903	2211503 or 2211504	2SA950-O or 2SA950-Y
Q103, Q110	2213290	DTC114ES
Q107	2212600	DTA124ES
Q111, Q113	2211455	2SA1015-GR
Q112	2211255	2SC1815-GR
Q119, Q120	2212524	2SK363-GR
Q123, Q124	2211705 or 2211706	2SD655-E or 2SD655-F
Diodes		
D101-D107	223163	1SS133
D108	224450562	MTZ5.6B
D901	22380013	RDF02M
D902	223163	1SS133
D903	224452202	MTZ22B
D904	224450512	MTZ5.1B
D905, D906	223163	1SS133
X'tal		
X101	3010112	KD6586FFB
Coil		
L101	231023	NCH-1062
Ferrite beads		
L102-L105	230906	BL02RN2-R62
L107-L110	230906	BL02RN2-R62
Filter		
L106	3030002	DSS306-55B-101M

CIRCUIT NO.	PART NO.	DESCRIPTION	CIRCUIT NO.	PART NO.	DESCRIPTION
	Capacitors				
C101, C112	354721019	100 μ F, 6.3V, Elect.	C193, C194	374723934	0.039 μ F 5%, 50V, Plastic(TF)
C102	371124724	4700pF 5%, 50V, Mylar	C195, C196	374721524	1500pF 5%, 50V, Plastic(TF)
C104	371121034	0.01 μ F 5%, 50V, Mylar	C197, C198	372122214	220 pF 5%, 50V, Styrole
C105, C106	354721019	100 μ F, 6.3V, Elect.	C199, C200	374723924	3900pF 5%, 50V, Plastic(TF)
C107, C108	371121034	0.01 μ F 5%, 50V, Mylar	C201, C202	354782219	220 μ F, 50V, Elect.
C109	371124724	4700pF 5%, 50V, Mylar	C203, C204	374722224	2200pF 5%, 50V, Plastic(TF)
C110	371122224	2200pF 5%, 50V, Mylar	C207, C208	373632224	2200pF 5%, 100V, Plastic(KP)
C111	371121034	0.01 μ F 5%, 50V, Mylar	C209-C214	354782219	220 μ F, 50V, Elect.
C115	354721019	100 μ F, 6.3V, Elect.	C911, C912	354753329	3300 μ F, 25V, Elect.
C121	371121024	1000pF 5%, 50V, Mylar	C913	354782219	220 μ F, 50V, Elect.
C122, C123	371121044	0.1 μ F 5%, 50V, Mylar	C914	354764709	47 μ F, 35V, Elect.
C124	371121034	0.01 μ F 5%, 50V, Mylar	C915, C916	354721029	1000 μ F, 6.3V, Elect.
C125	354780479	4.7 μ F, 50V, Elect.	C917	354764709	47 μ F, 35V, Elect.
C131	371122234	0.022 μ F 5%, 50V, Mylar	C918	354780229	2.2 μ F, 50V, Elect.
C132	371121024	1000pF 5%, 50V, Mylar	C919	354742229	2200 μ F, 16V, Elect.
C133	371121044	0.1 μ F 5%, 50V, Mylar	C920	354751029	1000 μ F, 25V, Elect.
C138	354780109	1 μ F, 50V, Elect.		Resistors	
C139, C146	354744709	47 μ F, 16V, Elect.	R108	5210066	N06HR22KBD, Semi-fixed
C147	354780109	1 μ F, 50V, Elect.	R110	5210060	N06HR2.2KBD, Semi-fixed
C148	371123334	0.033 μ F 5%, 50V, Mylar	R122, R132	5210066	N06HR22KBD, Semi-fixed
C149	354782299	0.22 μ F, 50V, Elect.	R154	5210058	N06HR1KBD, Semi-fixed
C150	374724744	0.47 μ F 5%, 50V, Plastic(IF)	R179	49163472404	4.7k \times 4, 1/10W, Network
C153, C154	354744709	47 μ F, 16V, Elect.	R207, R208	5210070 or 5210221	N06HR100KBD Semi-fixed
C155-C157	354721019	100 μ F, 6.3V, Elect.		Plugs	
C159	354721019	100 μ F, 6.3V, Elect.	P101	25055152	NPLG-8P136
C164	354780479	4.7 μ F, 50V, Elect.	P102	25055153	NPLG-9P137
C165	354724719	470 μ F, 6.3V, Elect.	P103	25055148	NPLG-4P132
C166	354782299	0.22 μ F, 50V, Elect.	P104	25055149	NPLG-5P133
C167	371121034	0.01 μ F 5%, 50V, Mylar	P106, P108	25055038	NPLG-2P29
C173, C174	354721019	100 μ F, 6.3V, Elect.	P107	25055045	NPLG-4P33
C177	371121044	0.1 μ F 5%, 50V, Mylar		Jack	
C178, C179	354744709	47 μ F, 16V, Elect.	P105	25045172	HSJ1003-01-020
C187-C190	354721019	100 μ F, 6.3V, Elect.			
C191, C192	372121014	100 pF 5%, 50V, Styrole			

CIRCUIT NO.	PART NO.	DESCRIPTION
P109	Terminal 25045259	NPJ-2PDBL128, Output
J1	Socket 2009990067	NSAS-2P0103
	Radiator 27160176	RAD56
	Screw 82143006	3P+6FN(BC), Pan head
QF101, QF102	Fuses 252112	△ ICPN15, IC protector <G>

DISPLAY CIRCUIT PC BOARD(NADIS-3836-1)

CIRCUIT NO.	PART NO.	DESCRIPTION
Q701	FL tube 212080	8-BT-94GK
S701-S713	Switches 25035548	NPS-111-S510
	Holder 27190754	FL tube

HEADPHONE AMPLIFIER PC BOARD (NAAF-3837-1/1A)

CIRCUIT NO.	PART NO.	DESCRIPTION
Q301	IC 222887	NJM4556S
C303, C304	Capacitors 354744709	47 μ F, 16V, Elect.
L301-L303	Ferrite beads 230905	BL02RN1-R62

CIRCUIT NO.	PART NO.	DESCRIPTION
P301	Jack 25045256	YKB21-5010 <D>
	25045255	YKB21-5009 <G>

POWER SUPPLY PC BOARD(NAPS-3838-1)

CIRCUIT NO.	PART NO.	DESCRIPTION
C951	3500065A	△ DE7150FZ103P AC400V/125V, Capacitor IS
S951	25035558	△ NPS-111-L520P, Power switch

NOTE: <G>: Only 220/240V/Worldwide models
<D>: Only 120V model

NOTE: THE COMPONENTS IDENTIFIED BY MARK
△ ARE CRITICAL FOR RISK OF FIRE AND
ELECTRIC SHOCK. REPLACE ONLY WITH
PART NUMBER SPECIFIED.

BLOCK DIAGRAM

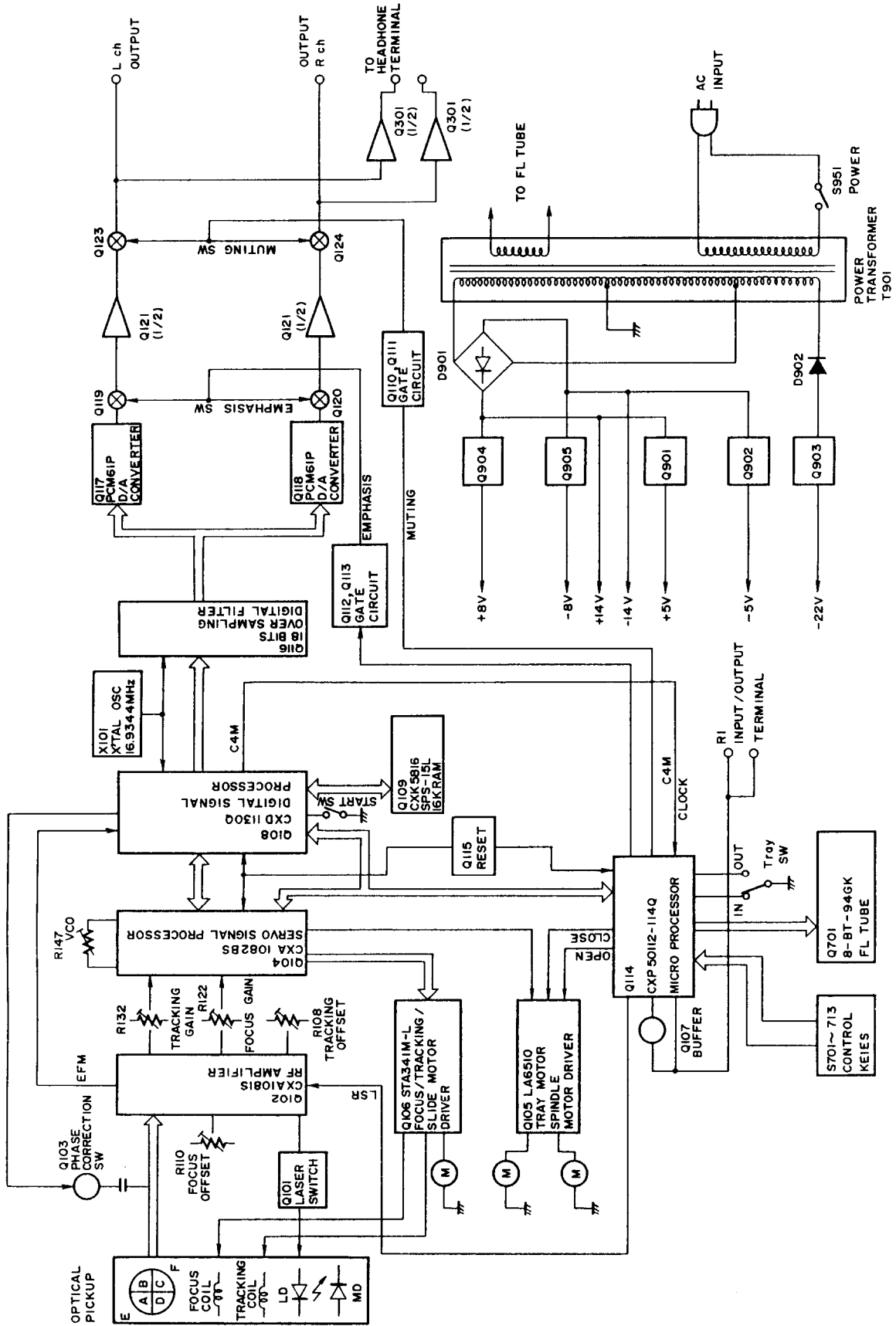

DX-1400

PACKING VIEW

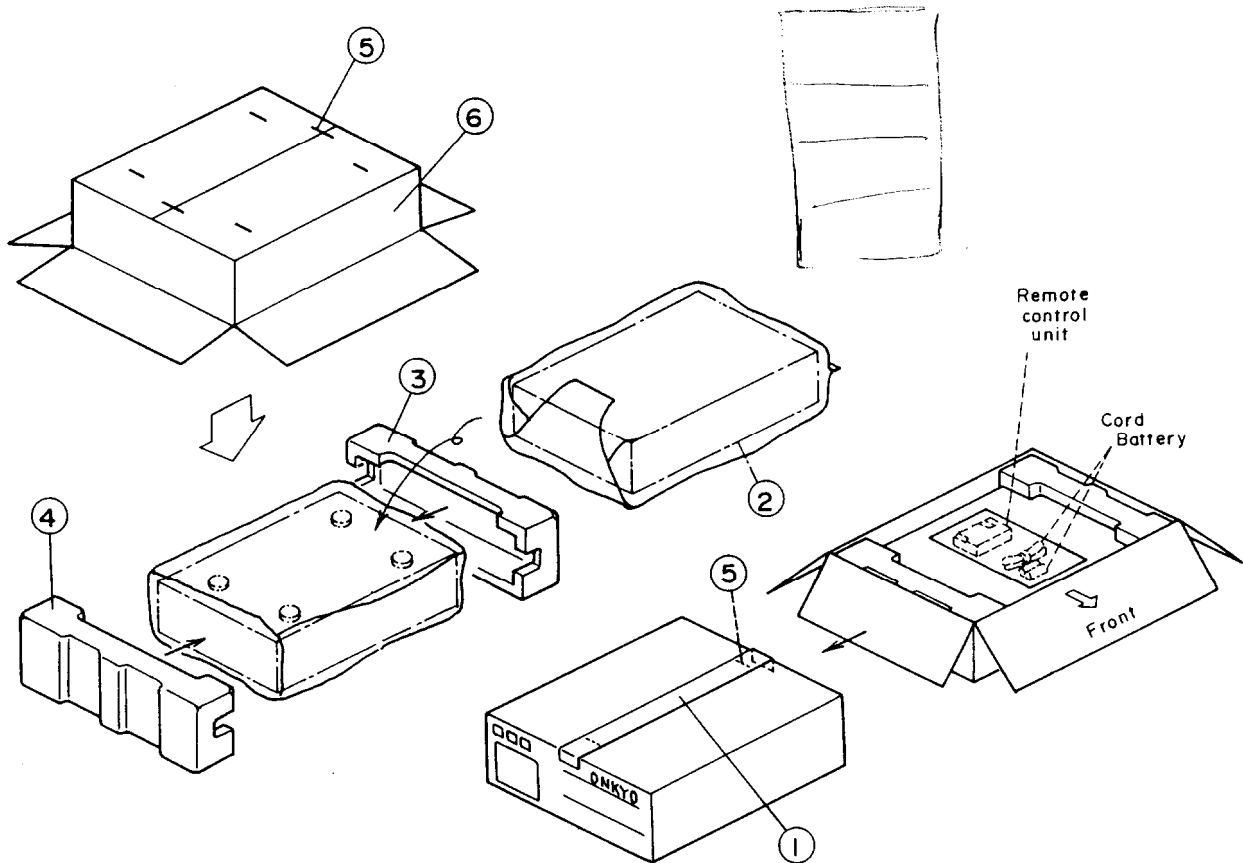

REF. NO.	PART NO.	DESCRIPTION
1	29110071-1	50×600mm. Damplon tape
2	29100037	500×650mm, Poly-vinyl bag
3	29091394	Pad R
4	29091393	Pad L
5	282301	Sealing hook
6	29052040	Master carton box
	29095505	Protection sheet, Tray panel
Accessory bag ass'y		
-120V models-		
	2010098A	Connection cord
	29341497	Instruction manual
	29100097	350×250mm, Poly-vinyl bag
	2010200	Connection cord for remote control
	29365019	Warranty card (Only U.S.A. model)
	29358002G	Service station list (Only U.S.A. model)
-220/240V models-		
	2010098A	Connection cord
	29341499	Instruction manual
	29100097	350×250mm, Poly-vinyl bag
	2010200	Connection cord for remote control
-Worldwide models-		
	2010098A	Connection cord
	29341499	Instruction manual
	29100097	350×250mm, Poly-vinyl bag
	2010200	Connection cord for remote control
	25055040	CV-K-2, Conversion plug

ONKYO CORPORATION

International Division: Onarimon Yusen Bldg., 23-5, Nishi-Shimbashi 3-chome, Minato-ku,
 TOKYO 105, JAPAN Tel: 03-432-6987 Fax: 03-436-6979
ONKYO U.S.A. CORPORATION
 200 Williams Drive, Ramsey, N.J. 07446, U.S.A. Tel: 201-825-7950 Fax: 201-825-8150