

ONKYO® SERVICE MANUAL

COMPACT DISC PLAYER MODEL DX-320

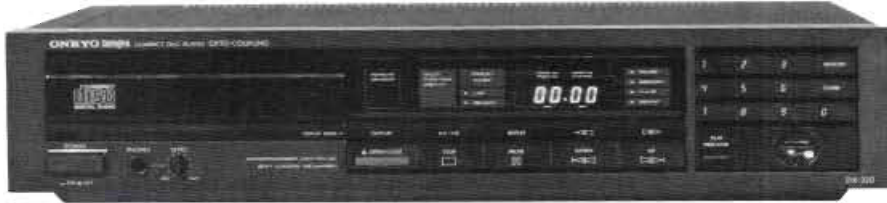

BUDN, BUD	120V AC, 60Hz
BUG	220V AC, 50Hz
BUW, BUWX	120/220V AC, 50/60Hz
BUQA	240V AC, 50Hz

SAFETY-RELATED COMPONENT WARNING!!

COMPONENTS IDENTIFIED BY MARK \triangle ON THE SCHEMATIC DIAGRAM AND IN THE PARTS LIST ARE CRITICAL FOR RISK OF FIRE AND ELECTRIC SHOCK. REPLACE THESE COMPONENTS WITH ONKYO PARTS WHOSE PARTS NUMBERS APPEAR AS SHOWN IN THIS MANUAL.

MAKE LEAKAGE-CURRENT OR RESISTANCE MEASUREMENTS TO DETERMINE THAT EXPOSED PARTS ARE ACCEPTABLY INSULATED FROM THE SUPPLY CIRCUIT BEFORE RETURNING THE APPLIANCE TO THE CUSTOMER.

SPECIFICATIONS

Type:	Compact Disc player with optical pickup
Quantization:	16 bit linear
Channels:	2 (Stereo)
Frequency response:	2Hz ~ 20kHz \pm 0.5dB
Dynamic range:	96dB
Total harmonic distortion:	0.003% (1kHz)
Channel separation:	93dB
S/N ratio:	96dB
Wow and flutter:	Unmeasurable
Output:	2.0 volts
Pickup:	Semiconductor laser type
Power consumption:	22 watts
Dimensions:	435(W) x 92(H) x 357(D) mm 17-1/8" x 3-5/8" x 14-1/16"
Weight:	5.8kg, 12.8lbs.
Accessories:	Connection cables Instruction manual Remote control

Specifications are subject to change without notice.

ONKYO
AUDIO COMPONENTS

TABLE OF CONTENTS

Specifications	1
Precautions	2
Notes on compact disc	3
Protection of eyes from laser beam	4
Laser warning labels	4
Cautions on replacement of pick-up	6
Packing view	7
Chassis exploded view	8
Parts list	9
Mechanism exploded view	10
Parts list	11
Flow chart of operation	12
Circuit description	16
Block diagram	25
Block diagram of ICs	26
Adjustment procedures	32
Printed circuit board view/Parts list	35

PRECAUTIONS

1. Removing the Transport Screws and Locking Plate

Three transport screws and locking plate are located on the bottom panel of this unit. Before using this unit for the first time, these screws and the plate must be removed. If power is switched on while these parts are still in place, the unit will not operate properly.

1. Locking plate
- 2/4. Transport screws
3. Spacers

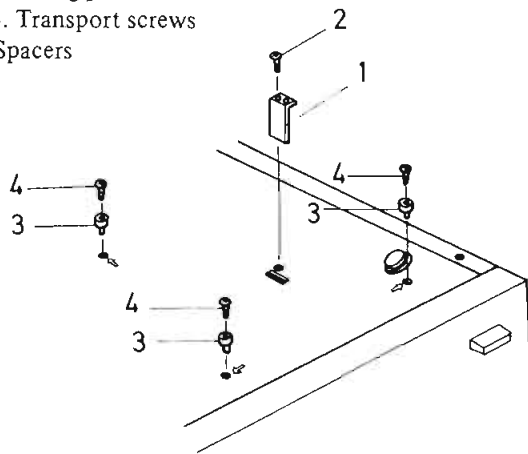

Fig. 1

2. Safety-check out (U.S.A. model)

After correcting the original service problem, perform the following safety check before releasing the set to the customer:

Connect the insulating-resistance tester between the plug of power supply cable and chassis.

Specifications: more than 10Mohm at 500V.

3. Procedures for replacement of flat packaged ICs

1. Tools to be used:

- (1) **Soldering iron** Grounded soldering iron or soldering iron with leak resistance of 10 Mohms or more.

Form of soldering iron's tip:

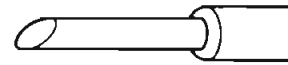

Fig. 2

- (2) **Magnifying glass** for checking of finished works
- (3) **Tweezers** for handling of IC and forming of leads
- (4) **Grounding ring** Countermeasure for electrostatic breakdown
- (5) **Nipper** for removing defective IC
- (6) **Small brush** for application of flux

2. Work Procedures:

(1) Remove the defective IC

Cut all leads of the defective IC one by one using a nipper and remove the IC.

(2) Clean the pattern surface of the PC board.

Get rid of the remaining leads and solder.

(3) Check and from the leads of the new flat packaged IC to be installed.

From every lead on the new IC using a pair of tweezers, so that all of them are aligned neatly without being risen, twisted or inclined toward one side. Especially the rising portion of every lead must be formed with greatest care.

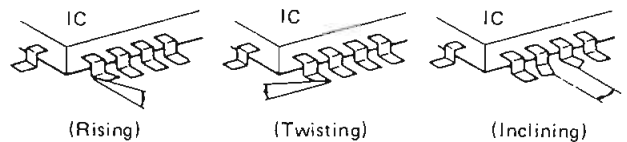

Fig. 3

(4) Apply flux to the PC board.

Apply flux to the pattern surface of the PC board which has been cleaned, as shown in the illustration. The area to be applied with flux is the portion of about 2.5mm in width where the IC's leads are to be soldered.

Be careful to apply minimum amount of flux required so as not to smear it on unwanted areas.

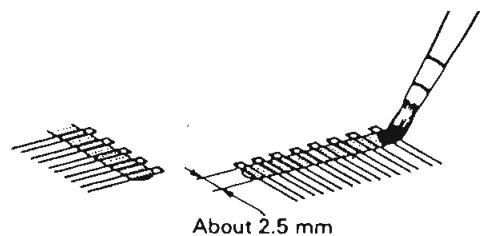

Fig. 4

(5) Temporarily tighten the IC

Carefully align the pattern and IC's leads, so that the IC will be temporarily tightened to the pattern on the four leads at the corners. At this time, soldering is required, but no need to apply soldering material.

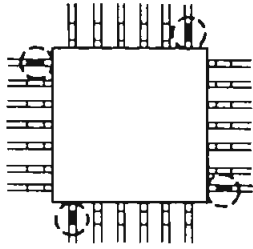

Fig. 5

(6) Apply flux to IC's leads

Apply flux to the areas of IC's leads where soldering is to be performed. Be careful not to smear flux on the root portion of any lead or the body of IC.

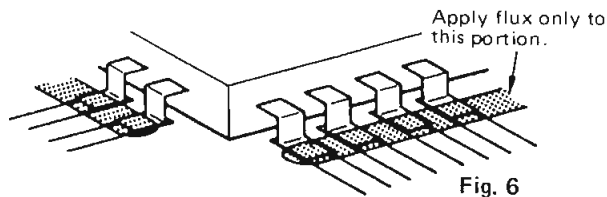

Fig. 6

(7) Soldering

While attaching the tip of the soldering iron to the soldering point as shown in the illustration, feed 2–5mm of soldering wire. Then, slowly move the iron in the direction indicated by the arrow in the illustration, so that the leads will be soldered to the pattern. Move the iron in the rate of approximately 1cm in 5sec. Proceed with your work while confirming a clean fillet of solder is formed on each lead, subsequent to the melting of flux.

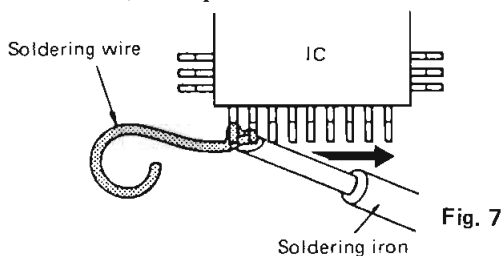

Fig. 7

CAUTION

- 1) If you move the iron too quickly, loose soldering is likely to result.
- 2) Be especially careful when soldering the first lead where loose soldering is most liable to be formed.

(8) Check the results

When soldering of all leads is finished, check the soldered portion on every lead with a magnifying glass. A tester must not be used or checking of any soldered position

NOTE ON COMPACT DISC**• Holding Compact Discs**

Hold Compact Discs by the edges so that you do not touch

the surface of disc. Remember that the side of the disc with the "rainbow" reflection is the side containing the audio information.

Do not attach tape or paper to the label side of the disc and always be careful not to leave fingerprints on the side that is played.

• Storing Compact Discs

Store Compact Discs in a location protected from direct sunlight, high heat and humidity and extremely high and low temperatures. Discs should never be left in the trunk or interior of an automobile in the sun since the temperature can become very high in such a closed environment.

Always store Compact Discs in the holders in which they were sold. Never leave a disc in the player's disc holder for a long period of time.

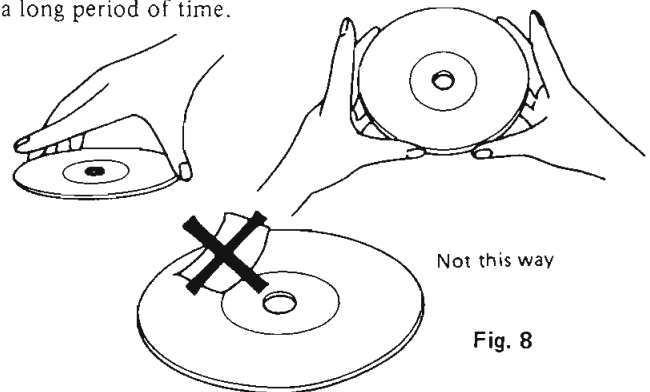

Fig. 8

• Cleaning Compact Discs

Before playing a disc wipe off the playing surface with a soft cloth to remove dust and other soil. Wipe the surface in straight lines from the center of the disc outward, not in a circular motion as you would with a phonograph record.

Do not use benzene, chemical cleansers or phonograph record cleaning solutions to clean Compact Discs. Also avoid static electricity prevention solutions since they can damage the surface of Compact Discs.

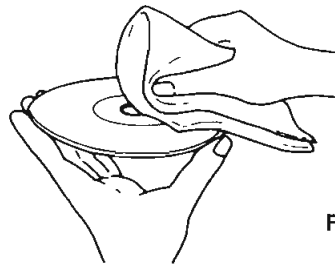

Fig. 9

Problems Caused by Dew

Dew can form inside a Compact player when it is brought from a cold environment into a warm room, when a room is rapidly heated and if a player is left in a humid environment.

This dew can prevent the laser pickup from reading the data contained in the pits in the disc surface. If the player does not operate properly because of dew, remove the disc and leave the player's power switch on for about one hour to remove all moisture.

PROTECTION OF EYES FROM LASER BEAM DURING SERVICING

This set employs a laser. Therefore, be sure to follow carefully the instructions below when servicing.

WARNING!!

WHEN SERVICING, DO NOT APPROACH THE LASER EXIT WITH THE EYE TOO CLOSELY. IN CASE IT IS NECESSARY TO CONFIRM LASER BEAM EMISSION, BE SURE TO OBSERVE FROM A DISTANCE OF MORE THAN 30cm FROM THE SURFACE OF THE OBJECTIVE LENS ON THE OPTICAL PICK-UP BLOCK.

Laer Diode Properties

- Material: GaAS/GaAlAs
- Wavelength: 780nm
- Emission Duration: continuous
- Laser output: max. 0.4mW*

*This output is the value measured at a distance about 1.8mm from the objective lens surface on the Optical Pick-up Block.

LASER WARNING LABELS

The labels shown below are affixed.

1. Warning labels

120V model

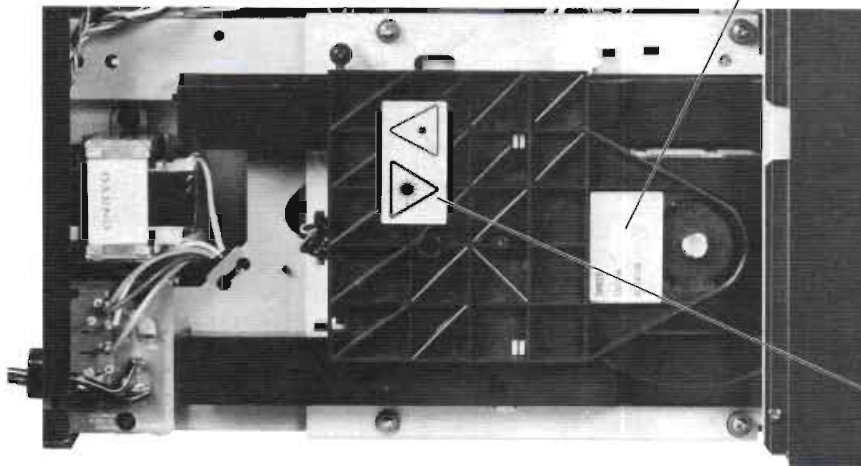

Photo 1

Other models

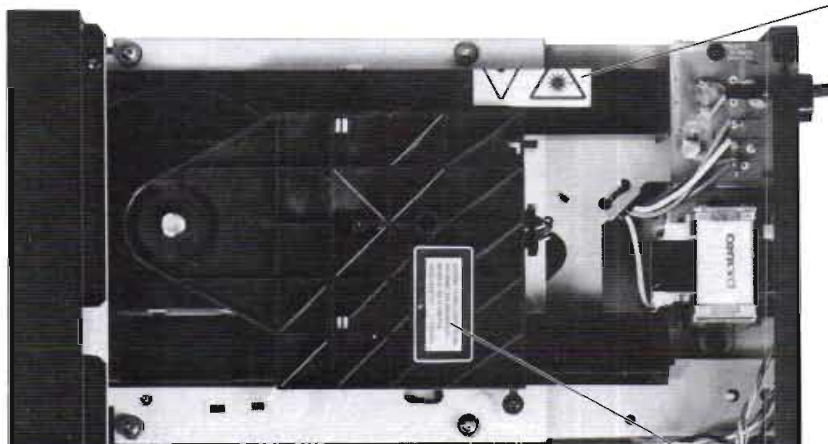
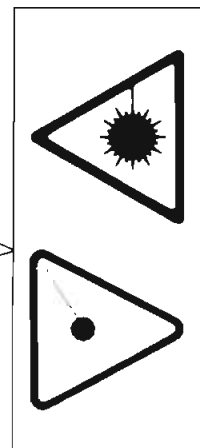

Photo 2

DANGER — INVISIBLE LASER RADIATION WHEN OPEN AND INTERLOCK FAILED OR DEFEATED. AVOID DIRECT EXPOSURE TO BEAM.

CAUTION — HAZARDOUS LASER AND ELECTROMAGNETIC RADIATION WHEN OPEN AND INTERLOCK DEFEATED.

ATTENTION — RAYONNEMENT LASER ET ELECTROMAGNETIQUE DANGEREUX SI OUVERT AVEC L'ENCLenchement DE SECURITE ANNULE.



ADVARSEL: USYNLIG LASERSTRÅLING VED ÅBNING, NÅR SIKKERHEDSAF-BRYDER ER UDE AF FUNKTION. UNDGÅ UDSÆTTELSE FOR STRÅLING.

2. Certification label (UD: 120V) model

This label is located on the back panel.



Photo 3

3. Class 1 label (Other models)

This label is located on the back panel.



Photo 4

ADVARSEL

"CLASS 1 LASER
PRODUCT"

Denne mærkning er anbragt på apparatets højre side og indikerer, at apparatet arbejder med laserstråler af klasse 1, hvilket betyder, at der anvendes laserstråler af svageste klasse, og at man ikke på apparatets yderside kan blive udsat for utilladelig kraftig stråling.

APPARATET BØR KUN ÅBNES AF FAGFOLK MED SÆRLIGT KENDSKAB TIL APPARATER MED LASERSTRÅLER!

ADVARSEL · USYNLIG LASERSTRÅLING
VED ÅBNING, NÅR SIKKERHEDSAF-
BRYDER ER UDE AF FUNKTION.
UNDGÅ UDSÆTTELSE FOR STRÅLING.

Indvendigt i apparatet er anbragt den her gengivne advarselmærkning, som advarer imod at foretage sådanne indgreb i apparatet, at man kan komme til at udsætte sig for laserstråling.

Fig. 10

CAUTIONS ON REPLACEMENT OF PICK-UP

The laser diode in the optical pick-up block is so sensitive to static electricity, surge current and etc. that the components are liable to be broken down or its reliability remarkably deteriorated.

During repair, carefully take the following precautions. (The following precautions are included in the service parts).

PRECAUTIONS

1. Ground for the work-desk.

Place a conductive sheet such as a sheet of copper (with impedance lower than $10^6\Omega$) on the work-desk and place the set on the conductive sheet so that the chassis.

2. Grounding for the test equipment and tools.

Test equipments and toolings should be grounded in order that their ground level is the same the ground of the power source.

3. Grounding for the human body.

Be sure to put on a wrist-strap for grounding whose other end is grounded.

Be particularly careful when the workers wear synthetic fiber clothes, or air is dry.

4. Select a soldering iron that permits no leakage and have the tip of the iron well-grounded.

5. Do not check the laser diode terminals with the probe of a circuit tester or oscilloscope.

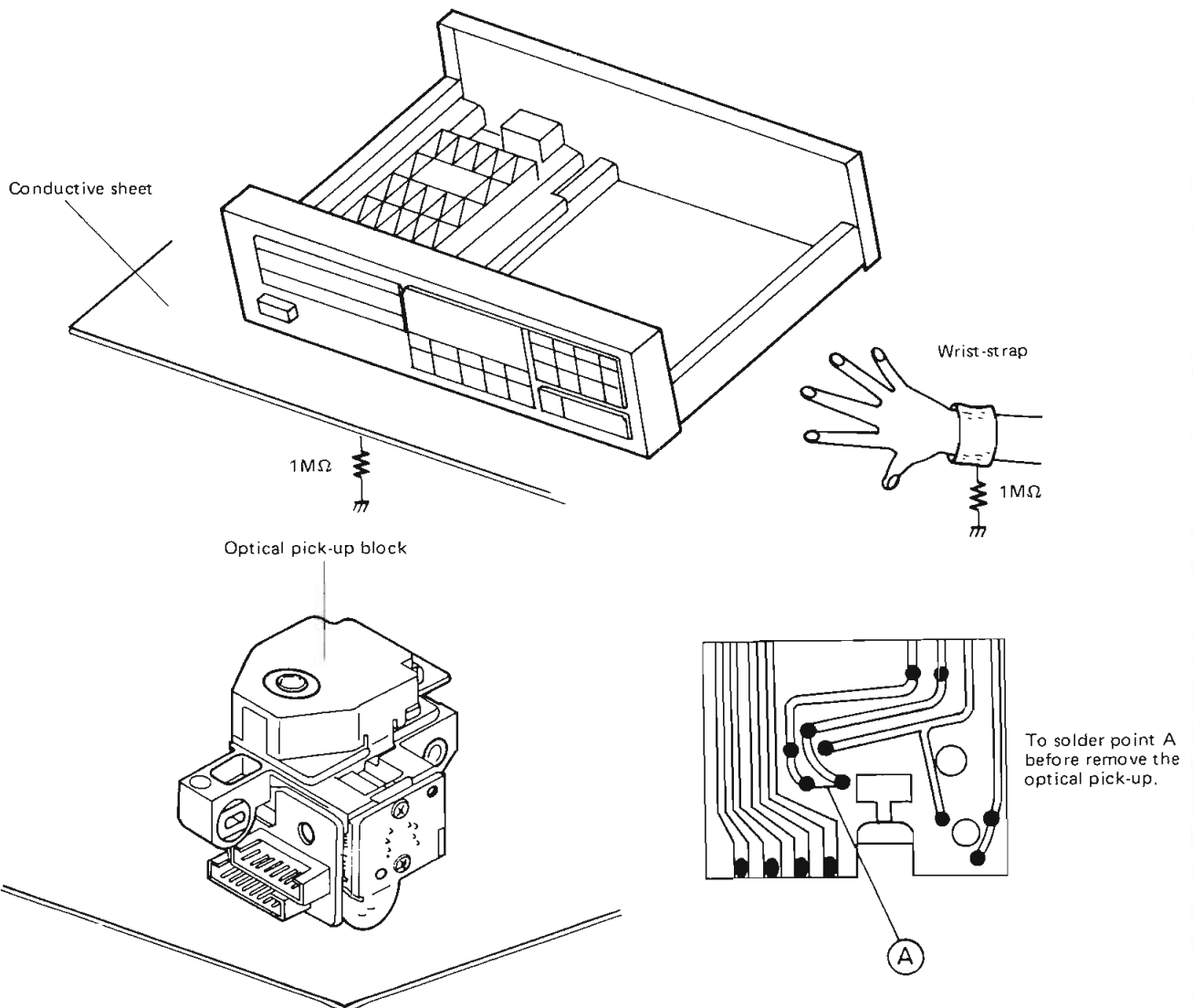

Fig. 11

PACKING VIEW

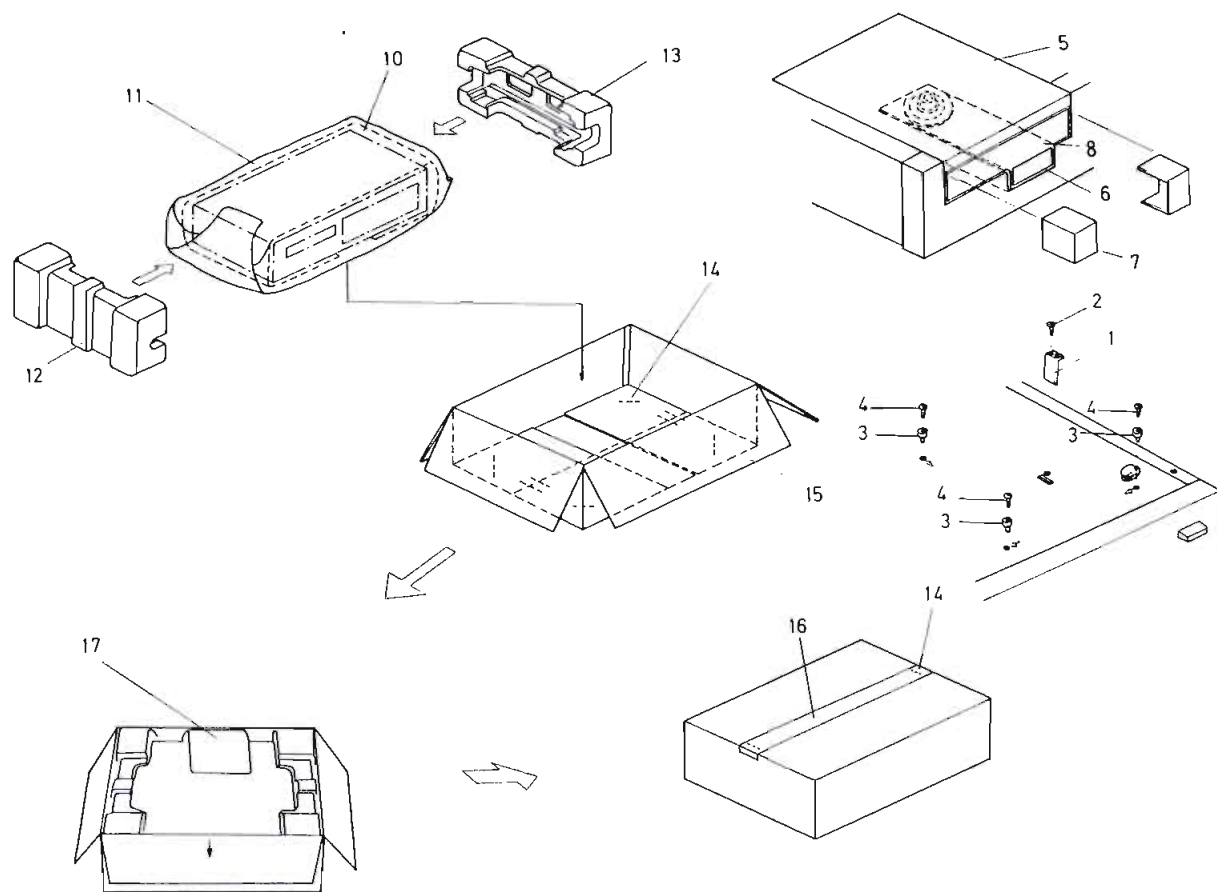

Fig. 12

REF. NO. PART NO. DESCRIPTION

1	27141023	Locking plate
2	834430068	3TTS+6B (BC), Tapping screw
3	27270169	Spacer
4	831430100	3TTW+10B (BC), Tapping screw
5	29360825	Label, caution
6	29360840	Label, sheet (120V model)
	29360687	Label (Other models)
7	29095407	Pad sheet
8	27270183	Spacer
9	29360833	Label
10	29095012-1	800 × 500mm, Protection sheet
11	29100036A	550 × 850mm, Poly-vinyl bag
12	29091077A	Pad L
13	29091078A	Pad R
14	283201	Sealing hook
15	29051294	Master carton box
16	260012	Damp tape
17		Accessory bag ass'y

U.S.A. model

2010097	Connection cable
241063	Remote control unit
3010054	UM-3, Two batteries
29340992A	Instruction manual
29100006A	350 × 250mm, Poly-vinyl bag
29365006-7	Warranty card
29358002C	Service station list

REF. NO. PART NO. DESCRIPTION

120V model

2010097	Connection cable
241063	Remote control unit
3010054	UM-3, Two batteries
29340992A	Instruction manual
29100006A	350 × 250mm, Poly-vinyl bag

220V model

2010097	Connection cable
241063	Remote control unit
3010054	UM-3, Two batteries
29340993	Instruction manual
29100006A	350 × 250mm, Poly-vinyl bag

Worldwide model

2010097	Connection cable
241063	Remote control unit
3010054	UM-3, Two batteries
29340993	Instruction manual
29100006A	350 × 250mm, Poly-vinyl bag

EXPLODED VIEW

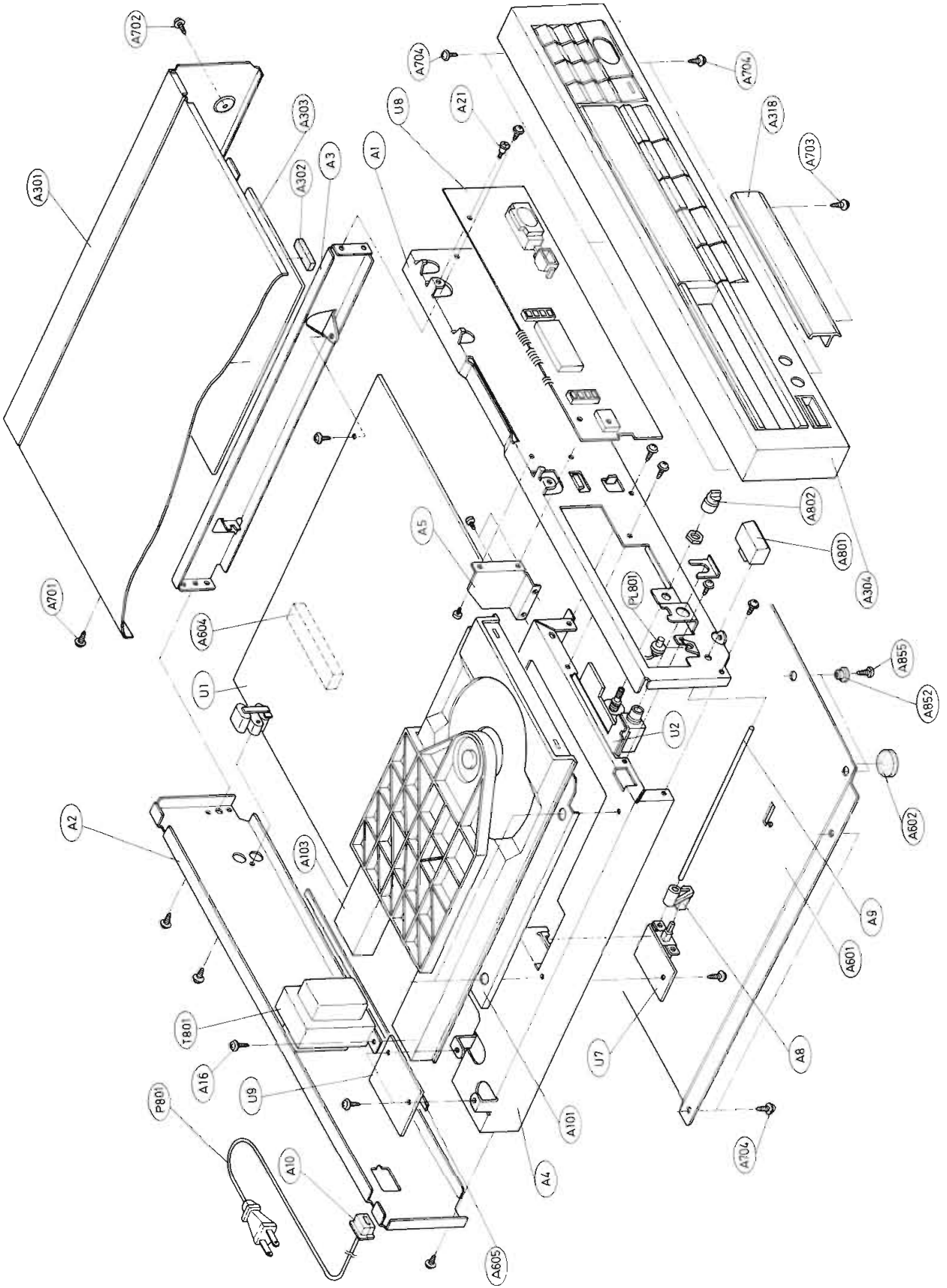



Fig. 13

PARTS LIST

REF. NO.	PART NO.	DESCRIPTION	REF. NO.	PART NO.	DESCRIPTION
A1	27110272B	Front bracket	P801	253123 or	AS-UC6#18 or
A2	27120836	Back panel [D]		253136	AS-UC6-2A, Power supply cord [D]
	27120837	Back panel [G]		253127 or	AS-CEE, Power supply cord
	27120839	Back panel [W]		253129	[G/W]
	27120874	Back panel [Q]		253118	AS-SAA, Power supply cord [Q]
A3	27115199A	Side bracket	PL801	210190	PL14V0.06AM4.0, Lamp
A4	27130420A	Bracket, mechanism	S801	25065123	NSS-1258P, Voltage selector switch [W]
A5	27141061	Bracket X		82143006	3P+6FN (BC), Pan head screw for S801 [W]
A8	27273047	Joint S	T801	2300071	NPT-911D, Power transformer [D]
A9	27260214	Shaft		2300072	NPT-911G, Power transformer [G]
A10	27300750	Strainrelief		2300073A	NPT-911DG, Power transformer [W]
A11	28140677	Cushion		2300074	NPT-911Q, Power transformer [Q]
A12	27270184	Spacer	U1	10458572-2	NAAF-2572-2, Main circuit pc board ass'y
A16	830440089	4TT+8C (BC), Tapping screw	U2	10458573-2	NAHP-2573-2, Headphone terminal pc board ass'y
A17	834430068	3TTS+6B (BC), Tapping screw	U7	10458591-2	NASW-2591-2, Power switch pc board ass'y
A18	833430080	3TTP+8B (BC), Tapping screw	U8	10458578-2	NADS-2578-2, Terminal pc board ass'y
A19	834230108	3TTS+10B (NI), Nickel screw	U9	10023579-1	NAPS-2579-1, Power supply pc board ass'y
A20	831430088	3TTW+8B (BC), Tapping screw			[D/G/Q]
A21	801147A	Special screw		10450579-2A	NAPS-2579-2A, Power supply pc board ass'y [W]
A301	28184317	Top cover			
A302	28140020	Cushion			
A303	28140672A	Cushion L			
A304	10458321	Front panel ass'y			
A318	27210718B	Decoration panel S			
A319	27141002A	Bracket, lid			
A601	27170222B	Bottom board			
A602	27175028	Leg			
A604	28140679	Cushion			
A701	834430068	3TTS+6B (BC), Tapping screw			
A702	838440089	4TTB+8C (BC), Tapping screw			
A703	833430080	3TTP+8P (BC), Tapping screw			
A704	838430068	3TTB+6B (BC), Tapping screw			
A801	28322099	Knob, power			
A802	28322437	Knob, level			

NOTE: THE COMPONENTS IDENTIFIED BY MARK  ARE CRITICAL FOR RISK OF FIRE AND ELECTRIC SHOCK. REPLACE ONLY WITH PARTS NUMBER SPECIFIED.

NOTE: [D] : Only 120V model
[G] : Only 220V model
[Q] : Only 240V model
[W] : Only Worldwide model

MECHANISM EXPLODED VIEW

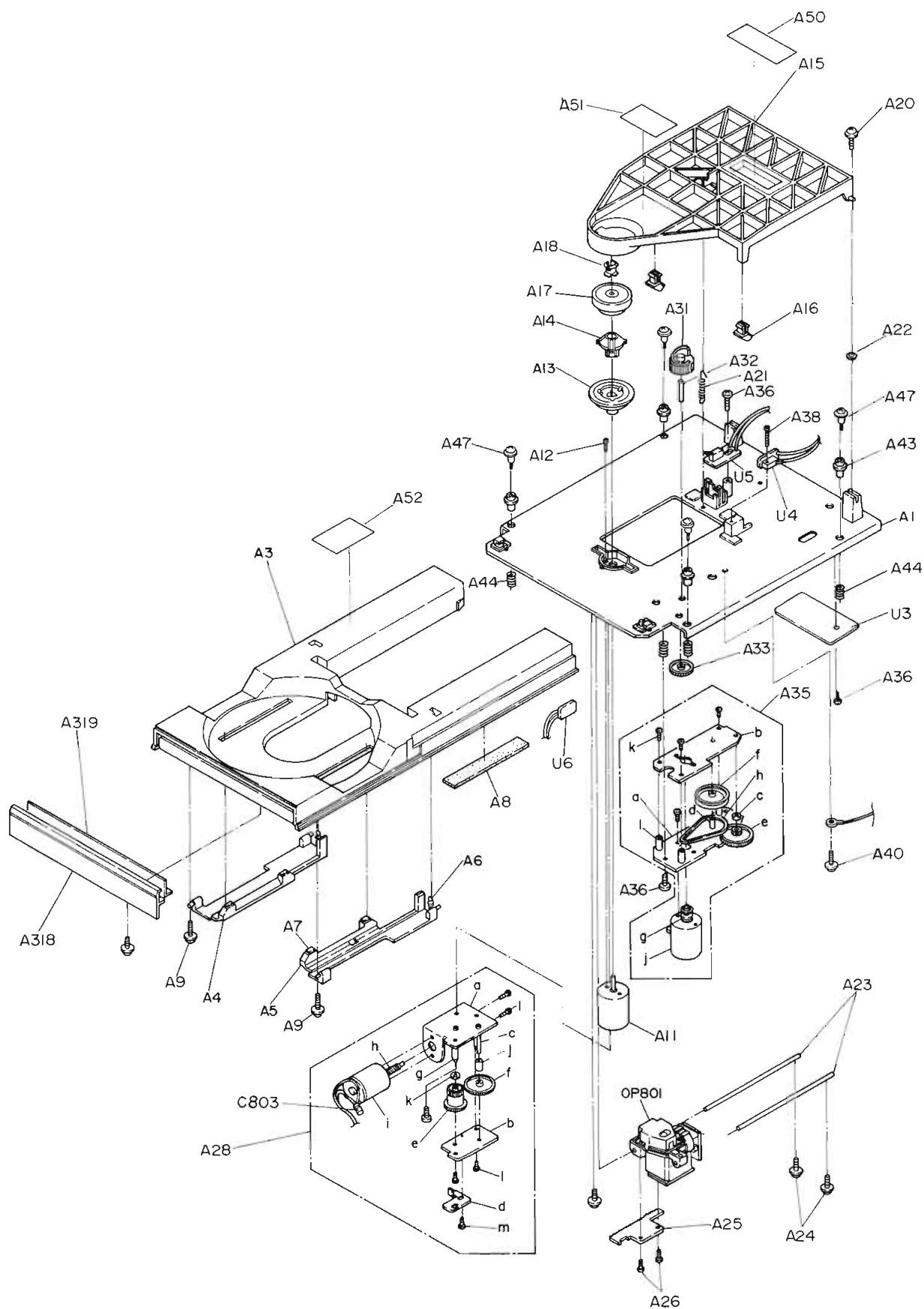

Fig. 14

PARTS LIST

REF. NO.	PART NO.	DESCRIPTION
A1	27100071F	Chassis M
A2	28140631	Cushion
A3	27300756C	Disc turntable
A4	28335031C	Lifter lever L
A5	28335032C	Lifter lever R
A6	27180242	Spring
A7	28140607	Cushion
A8	28140198	Cushion
A9	831430088	3TTW+8B (BC), Tapping screw
A11	24502197	NBS4R21, Spindle motor
A12	82142003	2P+3F (BC), Pan head screw
A13	27300797A	Turntable ass'y
A14	24506703C	Center spindle
A15	27300757-1	Arm
A16	27220035	Nail
A17	28330065A	Cap ass'y
A18	28330070A	Cap C
A19	833430080	3TTP+8P (BC), Tapping screw
A20	831430100	3TTW+10P (BC), Tapping screw
A21	27180280	Spring
A22	87643010	W3 × 10F (BC), Washer
A23	27260175	Shaft, pick-up
A24	831430100	3TTW+10P (BC), Tapping screw
A25	27300809A	Rack
A26	82142604	2.6P+4F, Pan head screw
A28	24506687	Pick-up motor ass'y
A31	27300758A	Cam
A32	27260176A	Shaft
A33	27300759	Gear
A35	24502179	Tray motor ass'y
A36	833430080	3TTP+8P (BC), Tapping screw
A38	833420108	2TTP+10B (BC), Tapping screw
A39	833430080	3TTP+8B (BC), Tapping screw
A40	834430068	3TTS+6B (BC), Tapping screw
A43	28140608B	Cushion rubber
A44	27180245-2	Spring, return
A47	801364	Special screw
A50	29360806A	Label, laser [D]
	29360811	Label [G/Q/W]
A51	29360807	Label, Danger [D]
A52	29360806A	Label, Laser [G/Q/W]
A55	833420068	2TTP+6B (BC), Tapping screw
C803	352942206	22 μ F, 16V, Non-polar elect. capacitor
OP801	241065	KSS-123A, Optical pick-up
SC801	2000587	NSAS-2P543, Socket, pick-up motor
SC802	2000585	NSAS-2P541, Socket, Spindle motor
SC803	2000586	NSAS-2P542, Socket, Tray motor
SC804	2000545	NSAS-8P501, Socket, Pick-up and P103 on the main pc board
SC805	2000546	NSAS-8P502, Socket, Pick-up and P101/P102 on the main pc board
U3	10023574-1	NARY-2574-1, Terminal pc board ass'y
U4	10023575-1	NAOS-2575-1, Open switch pc board ass'y
U5	10023576-1	NACS-2576-1, Close switch pc board ass'y
U6	10023577-1	NASS-2577-1, Slide motor pc board ass'y

NOTE: [D] : Only 120V model
 [G] : Only 220V model
 [Q] : Only 240V model
 [W] : Only Worldwide model

FLOW CHART OF OPERATION

1. Lead-in (TOC reading)

The major processing steps when a disc is loaded on the tray and the OPEN/CLOSE key is pressed are outlined below.

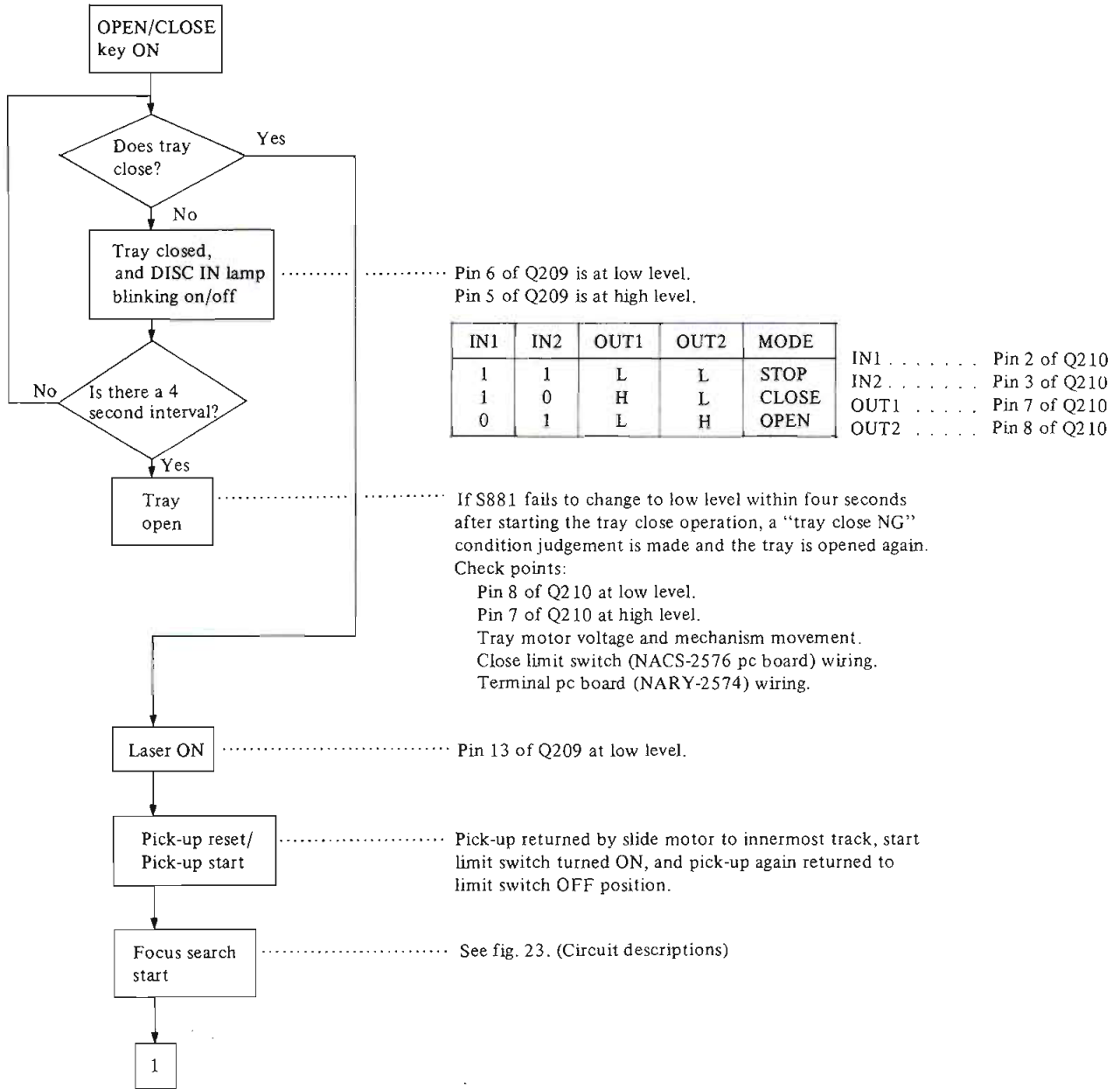

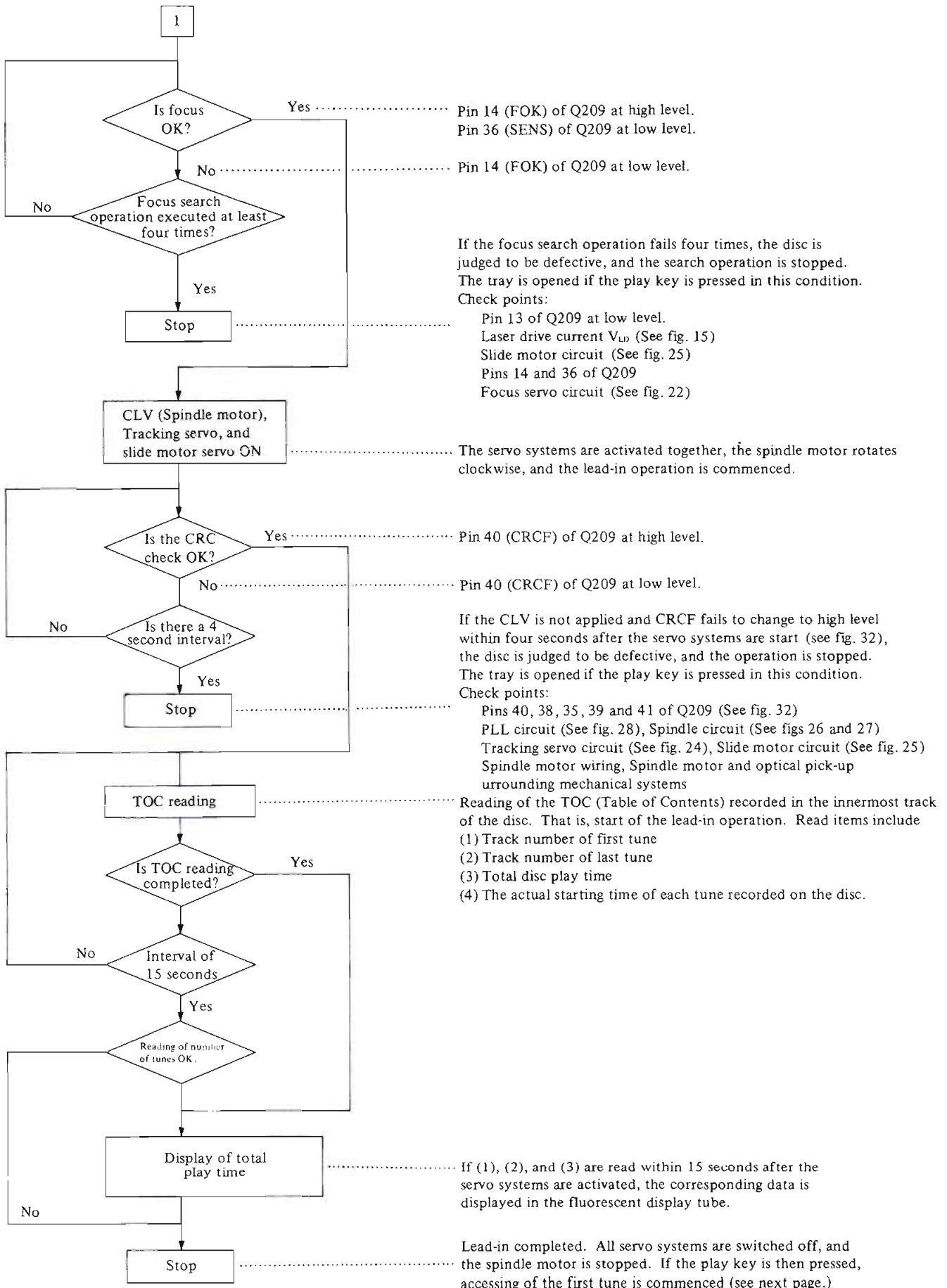

2. Location Start of Tune

The process up to start of play of the first tune when the play key is pressed after the lead-in operation has been complete is outlined below.

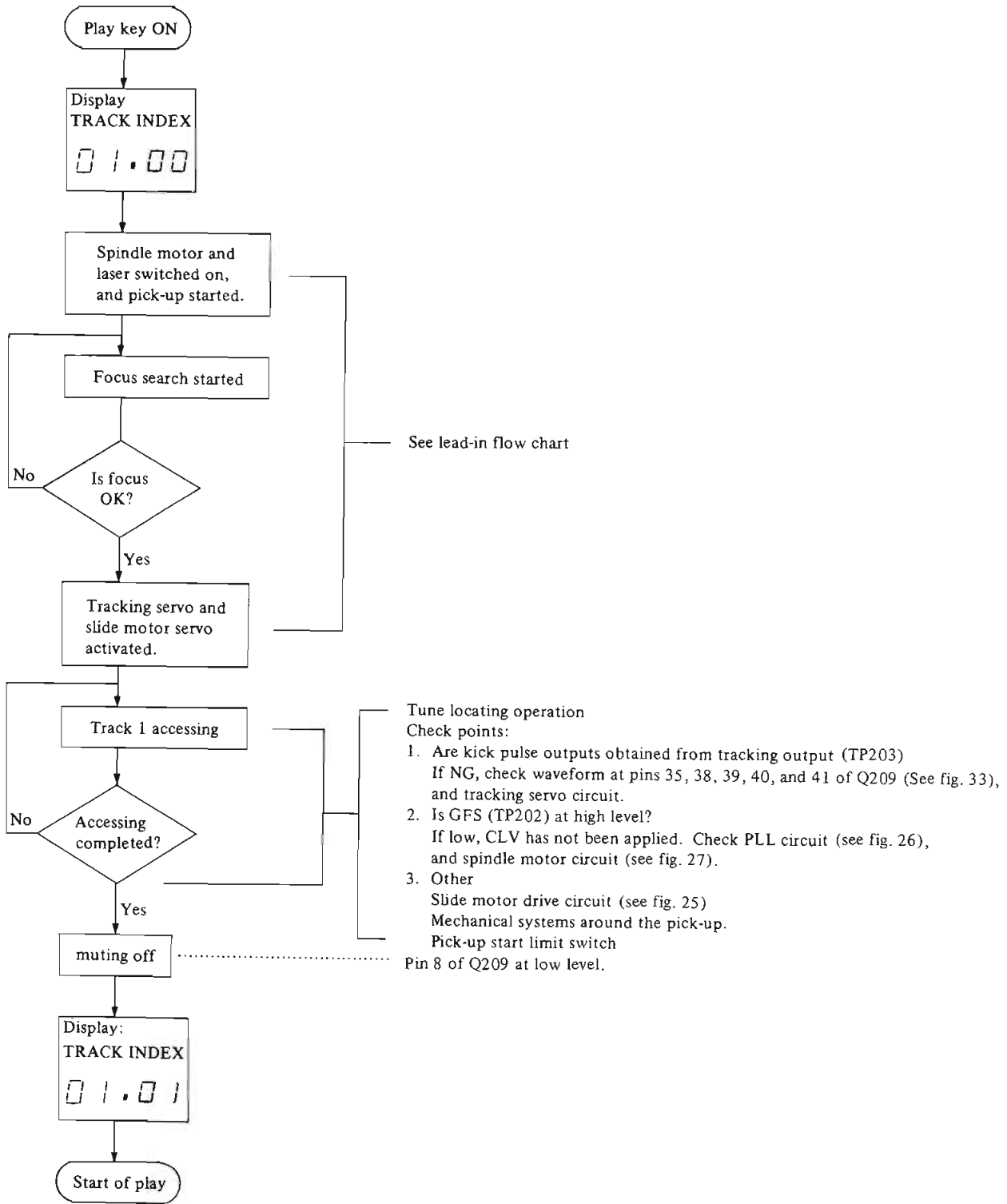

3. Flow Chart for Trouble Place Discovery

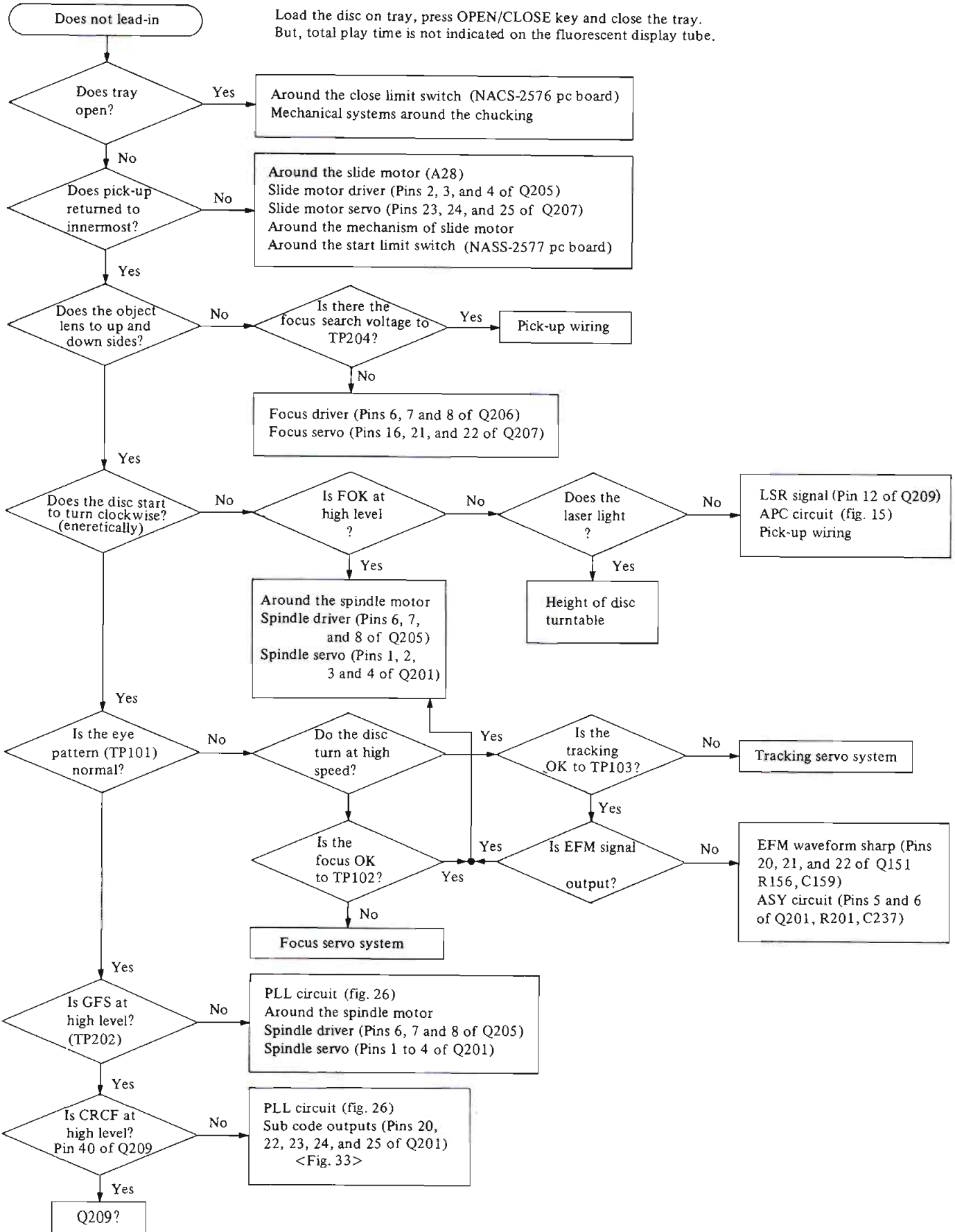

CIRCUIT DESCRIPTION

1. APC (Auto Power Control) Circuit

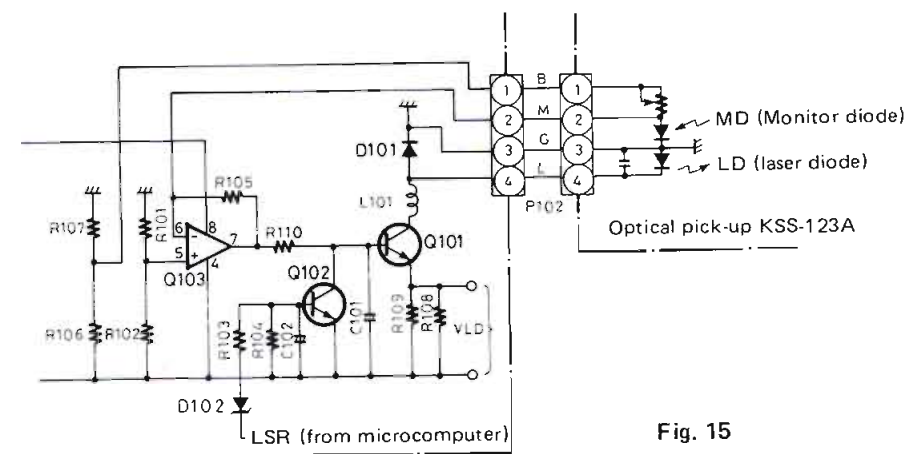

Fig. 15

The purpose of the APC circuit is to keep the laser diode optical output at a constant level (0.15 to 0.4mW, there being different values for different pick-ups).

When the LSR laser on/off control signal from the microcomputer (Pin 13 of Q209) is changed to low level, Q102 is turned off via D102 and R103, and Q101 is turned on to supply a current to the laser diode. This current I_{LD} is obtained from the following equation:

$$I_{LD} = V_{LD} / (R_{108} / R_{109}) = V_{LD} [V] / 21.5 [\text{ohm}]$$

where V_{LD} is the voltage measured between both sides of R108.

The I_{LD} value lies in the 50 to 80mA range when the laser diode is normal. The I_{LD} value for each pick-up is set prior to delivery from the factory, and is indicated as a three-digit number below the lot no. on the pick-up spindle motor. (For example, a figure of 691 indicates a current

of 69.1mA.) A measured current which differs from this value by more than 10% (at 25°C) indicates that the laser diode has probably deteriorated. Since the laser diode is very susceptible to the effects of static electricity, switch the CD player power off before connecting a digital voltmeter across both sides of R108 to measure V_{LD} . And after the measurement has been completed, again switch the power off before disconnecting the voltmeter.

The laser diode optical output is also beamed onto a monitor diode built into the optical pick-up. The light source current generated as a result is fed back to the minus input of the Q103 operational amplifier to maintain the laser output power at a constant level.

2. Focus Error Circuit

The focus error circuit is designed to detect changes in the distance to the disc, and thereby ensure that the laser beam spot is kept in proper focus on the reflecting surface of the disc.

This is achieved by what is called the astigmatic method which makes use of the fact that the shape of the laser beam spot reflected from the disc into a six-part photo diode in the pick-up varies according to the distance from the disc as indicated in Fig. 16. These changes are due to the action of a cylindrical lens.

The A, B, C, and D photo diode light source currents undergo a diagonal subtraction in three operational amplifiers in Q151, resulting in the generation of a focus error (FE) signal. FE signal changes at different distances from the disc reflecting surface are summarized by the curve in Fig. 16.

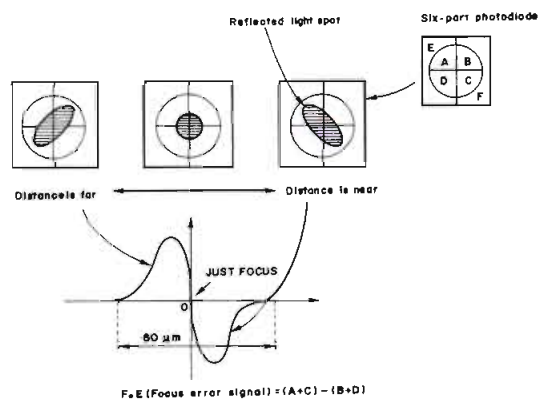

Fig. 16

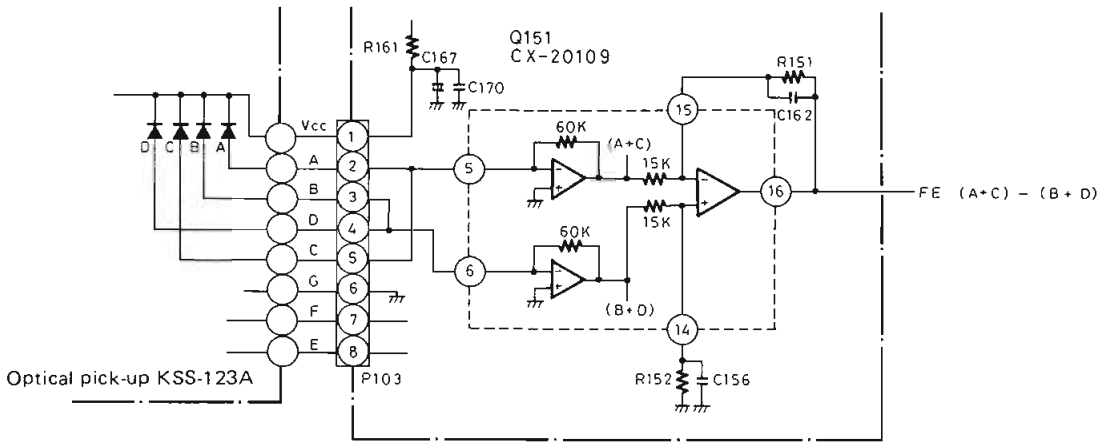

Fig. 17

3. Tracking Error Circuit

$$FE \text{ (Focus error Signal)} = (A + C) - (B + D)$$

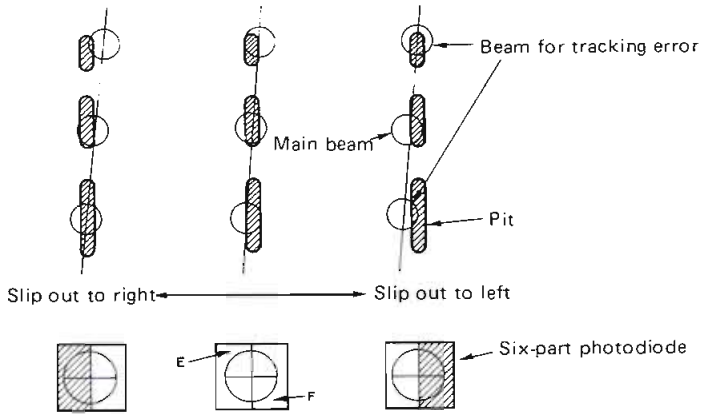

Fig. 18

The tracking error circuit generates an error signal if the laser beam spot moves away from the center of the pits. This error signal is used to ensure that the beam spot correctly tracks the line of pits.

This mechanism divides the laser beam into three separate beams – a main beam, and two auxiliary beams on both sides of the main beam and used specifically to detect tracking error. These three beams are arranged at a slight angle (0.88°) to the line of pits in what is known as the three beam method.

If the beam tends to move away from the pits as indicated in Fig. 18, the degree of reflection in the auxiliary beams will change depending on the direction of the shift.

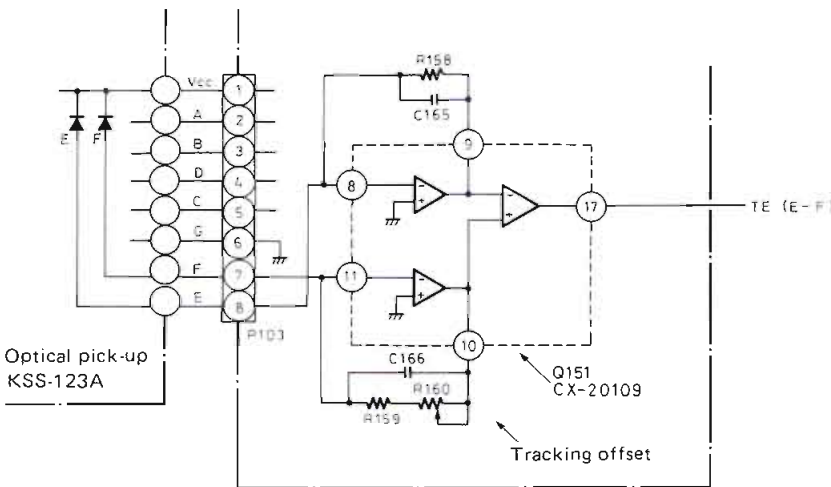
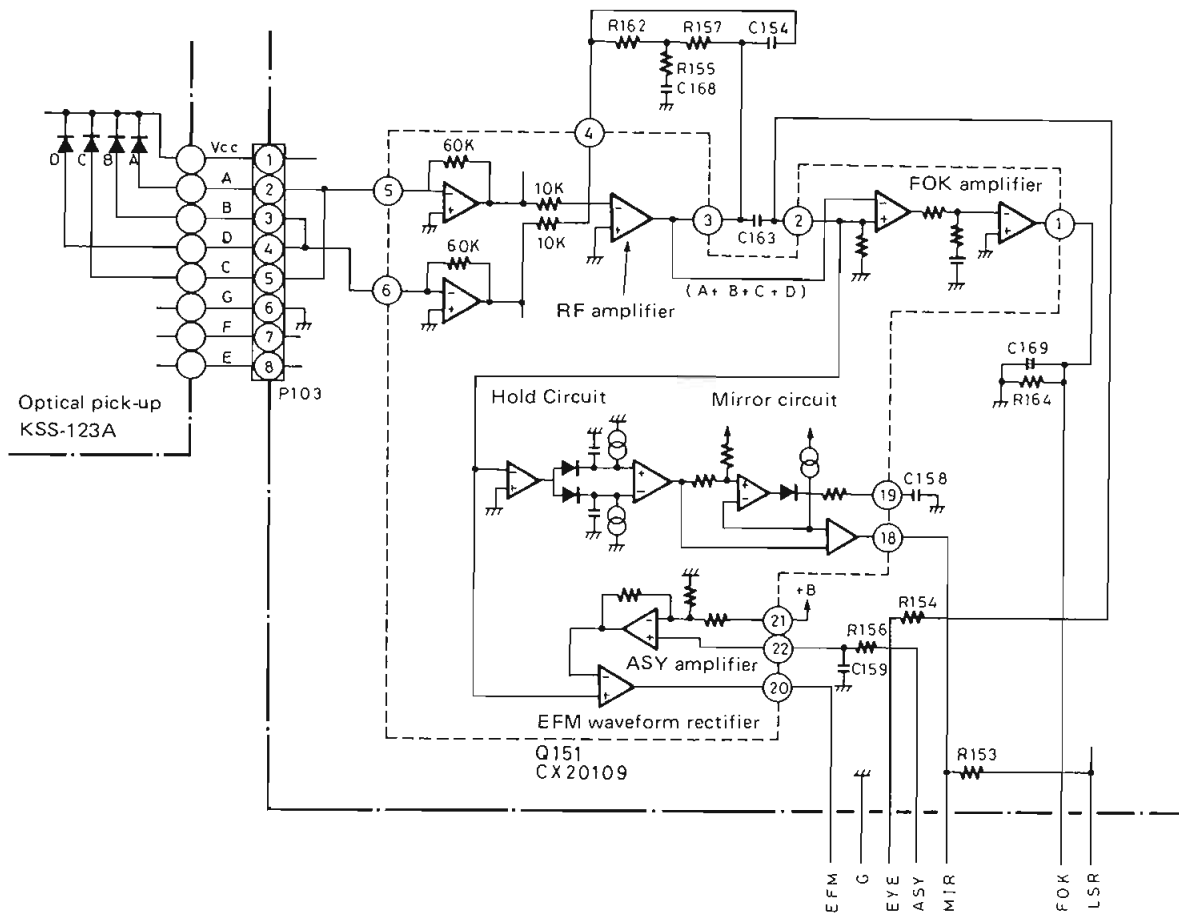

Fig. 19

The reflected auxiliary beams are converted into electric signals by the E and F detectors at both ends of a six-part diode, and the mutual differences are obtained as a tracking error (TE) signal.

The circuit includes three operational amplifiers. The E and F detectors are balanced by variable resistor R160, and the tracking offset is cancelled.

4. RF Amplifier, FOK, MIR, and EFM Waveform Rectifier



4.1 RF Amplifier

In addition to amplifying the RF signal (A+B+C+D) obtained from the photo detector, the RF amplifier is also used in equalization of the signal. By using R162, R157, R155, and C168 in the RF operational amplifier negative feedback loop (between pins 3 and 4 of Q151) to boost frequency components above 1MHz and to advance the phase, EYE (eye pattern) TP101 jitter components are suppressed. When the laser diode, servo systems, and disc are normal, the value of EYE (TP101) is 1.1 ± 0.2 [Vp-p] (see Fig. 21).

4.2 FOK (Focus OK) circuit

The FOK circuit generates a signal used to judge when the laser spot is on the reflecting surface of the disc. The FOK signal is high when the laser is "in focus".

The DC level of the RF signal (described in section 4.1) is compared with a reference voltage. If the DC level is higher than the reference voltage (which means that the light source current generated by the reflected beam is greater than the reference level) the comparator is activated and a high output is obtained from pin 1 of Q151.

The FOK output is applied to the microcomputer where it is used in disc identification, focus adjustment timing, and detection of disc flaws.

4.3 MIR (Mirror) Detection Circuit

The MIR detector circuit is used in detection of the mirror portion of the disc between tracks and outside the lead-out track, and also in detection of disc flaws. The differential output obtained by peak and bottom holding of the RF signal envelope is compared with a signal which is held by an even larger time constant (determined by C158). If the differential output drops below 2/3 of the hold signal, the comparator is activated to obtain a high level MIR output (from pin 18 of Q151).

This output is passed to the microcomputer and the PLL circuit (pin 7 of Q201), and is used in counting tracks when accessed, and in switching the PLL to open loop if a disc flaw is detected.

4.4 EFM Waveform Rectifier

This rectifier circuit is involved in binary conversion of the RF signal following input to the comparator. Since asymmetry in the RF signal about the X axis (generated as a result of various variable factors in the manufacture of compact discs and which results in loss of DC balance) cannot be eliminated simply by AC coupling, EFM signal DC components must be fed back after rectification to control the slice level.

The EFM output (pin. 20 of Q151) obtained by rectifying the RF signal by comparator is converted to CMOS level in Q201 to become the ASY (ASYMMETRY) signal. The low frequency components of this signal are feed back to pin 22 of Q151 via R156 and C159. The voltage of this pin 22 is approx. $2.5V$ (5/2) when operation is normal.

5. Focus Servo and Peripheral Circuits

5.1 Focus Servo Circuit

The focus servo circuit is used to ensure that the beam spot is always correctly focussed on the reflecting surface of the disc. This is done by feed back of the FE (focus error) signal to ensure that the object lens can respond to fluctuating perpendicular disc movements.

When the FE input from pin 16 of Q151 is passed to the R233 variable resistor, a DC offset voltage is added before the signal is applied to the R239 gain regulator and pin 20 of Q207. Although this pin is connected to ground via R240, C221, pin 18 of Q207, and switch FS3, this FS3 is on during accessing operations and the high frequency components in the FE signal are attenuated by about 10dB to suppress mechanical noise.

The FE signal applied to pin 20 of Q207 is passed via the servo on/off switch FS4 in Q207 and the phase compensating operational amplifier OP1 to appear at the pin 21 output. Then after the current level is increased by the Q206 driver, the signal is passed from P101 to the focus drive coil in the optical pick-up to control perpendicular object lens movement.

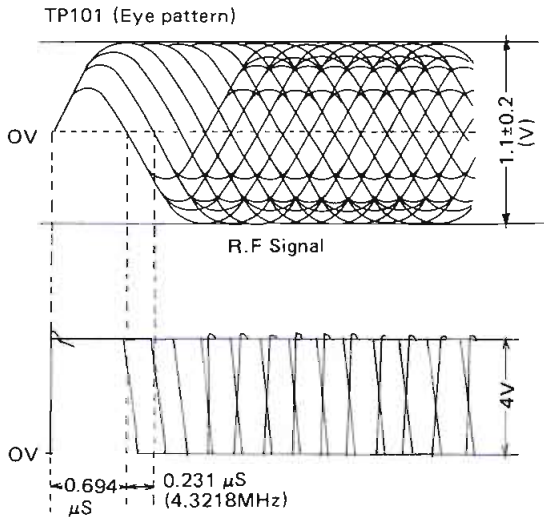

Fig. 21

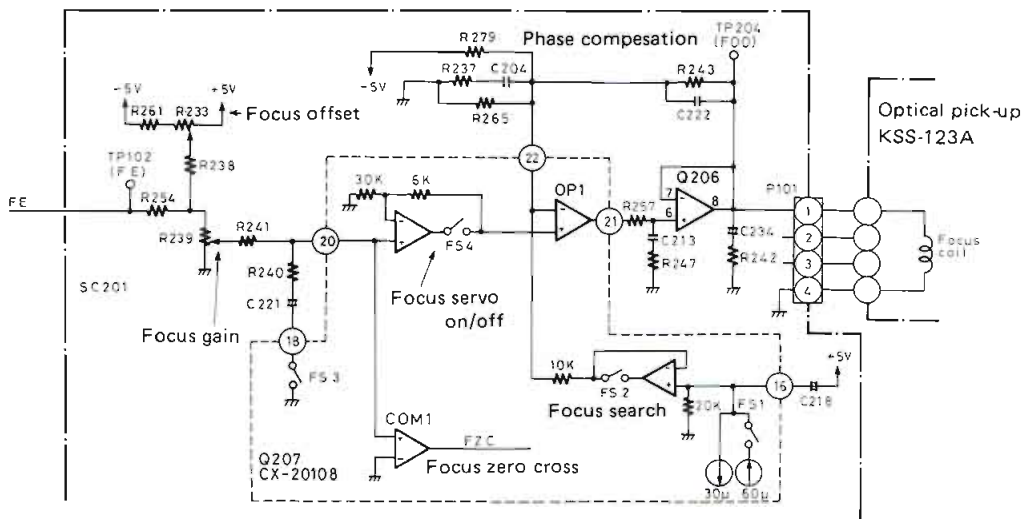

Fig. 22

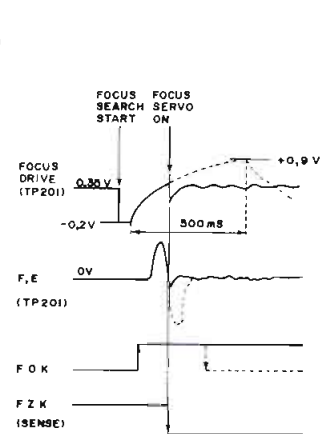

Fig. 23

5.2 FZC (Focus Zero Cross) Circuit

The FZC circuit detects when the FE signal reaches 0V, and is used together with the FOK circuit (see Section 4.2) in determining the focus adjustment timing.

The FE signal applied to pin 20 of Q207 is also passed to a comparator COM1 in the IC to form the FZC signal which is subsequently passed to the IC's logic section. When an instruction is received from the microcomputer, the FZC output signal is passed from pin 5 (SENSE) to the microcomputer.

5.3 Focus Search Circuit

Since the FE signal can only be obtained when within $\pm 30\mu\text{m}$ of the focus point (see Fig. 16), a focus search circuit is required to shift the object lens up and down in the beginning to find the focus point before closing the servo loop for stabilized focus servo operation.

FS2 and FS4 are off when the lens is stationary (see Fig. 22), and the focus drive output is kept at the bias voltage of approximately 0.35V by R279. When an instruction is received from the microcomputer, FS2 is switched on and FS1 is switched on and off every 500ms, resulting in C218 being charged up and discharged in repeated cycles. Consequently, a 1Hz delta wave signal is applied to focus coil to move the object lens up/down in search for the focus point.

The focus adjustment timing circuit is outlined in Fig. 23. When the delta wave signal is applied by the driver to the focus coil and the focus point is reached, the FOK signal is changed to high level and the FZC (SENSE) signal is changed to low. The microcomputer generates an

instruction for switching the focus servo on at that time, resulting in FS2 being switched off and FS4 on to close the loop. The dotted lines in Fig. 23 indicate the waveforms when the servo loop is not closed.

6. Tracking Servo and Peripheral Circuits

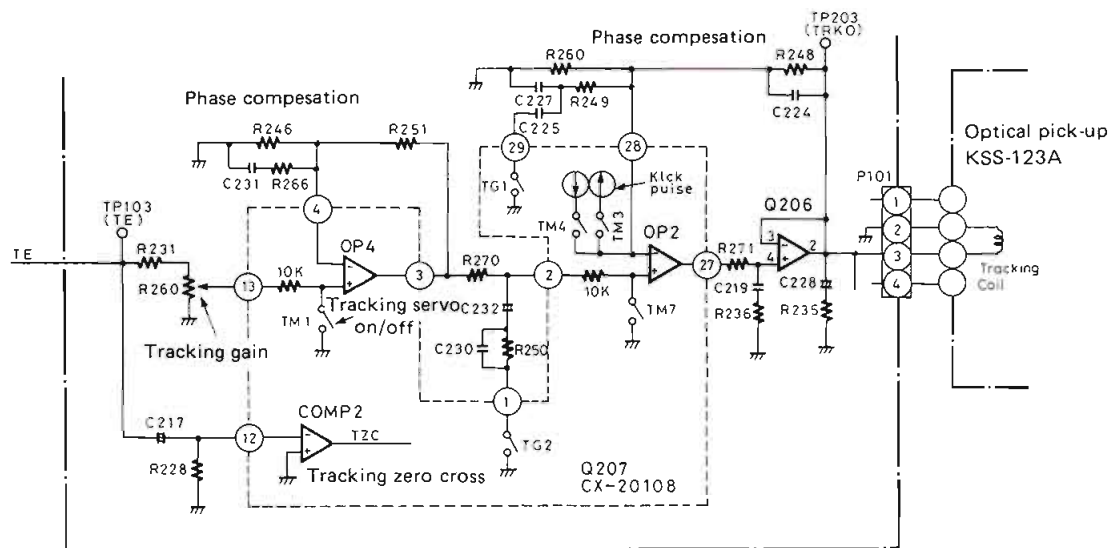

Fig. 24

6.1 Tracking Servo Circuit

The tracking servo circuit is designed to keep the beam spot constantly directed into the center of the pit track despite lateral disc movement due to eccentricity etc. This is done by feed back of the TE (tracking error) signal to ensure that the object lens can respond to fluctuating lateral disc movements.

The TE input from pin 17 of Q151 is passed to the R260 variable resistor for gain adjustment before being applied to pin 13 of Q207. The signal is passed via a phase compensating operational amplifier OP4 to pin 3, then to pin 2 to be passed through another phase compensating operational amplifier OP2. The output from pin 27 is then passed to the optical pick-up tracking coil by driver Q206 in order to drive the object lens.

The purpose of the R270, R250, C232, and C230 elements located between pins 2 and 3 of Q207 is to switch the gain for the high frequency by the pin 1 switch TG2. The frequency response can be switched by TG1 in combination with C225 connected to pin 1. These switching circuits are activated as a result of track kicking and track accessing in order to stabilize the tracking servo.

TM1 is the servo on/off switch.

6.2 TZC (Tracking Zero Cross) Circuit

The TZC circuit generates the timing for switching the tracking servo on and off following a track kicking action or when the number of tracks is counted together with the

MIR signal during track accessing. The low frequency components in the TE signal are removed by C217 and R228 before the signal is applied to the COMP2 comparator from pin 12 of Q207. Then in response to an instruction from the microcomputer, the output is passed from pin 5 (SENSE).

6.3 Track Kick Circuit

This track kick circuit is used when the laser beam is skipped to a relatively close pit track (from 1 to 100 tracks away) during track accessing and cue/review mode operations. Basically, this skipping is achieved by applying kick and brake pulses to the tracking coil with the tracking servo loop open.

TM1 is switched on to cut the servo loop at the same time that the negative/positive current source switches TM3 and TM4 connected to the negative input of OP2 in Q207 are switched on and off. Following a track kick, TG2 is switched off and TG1 is switched on to stabilize the dynamic characteristics of the servo loop. At the same time, the TZC and MIR signals are monitored, and the servo loop is switched on and off for better system initiating performance (by suppressing generation of vibration in the tracking system).

The timing for all of these operations is determined by microcomputer instructions.

7. Slide Motor Drive Circuit

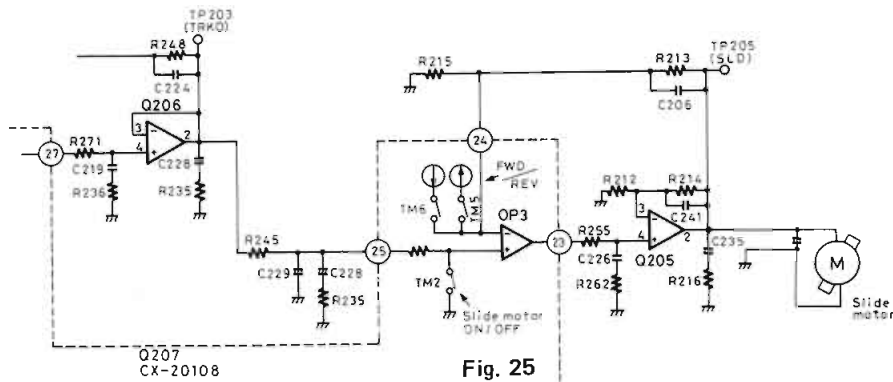

Fig. 25

The slide motor drive circuit (also called the feed motor servo circuit) is used to move the complete pick-up towards the outer edge of the disc, keeping the object lens constantly in line with the center of the optical axis.

When the object lens is being moved towards the edge of the disc while tracing the pit tracks under tracking servo control, the DC voltage at the tracking drive output

(TP203) is gradually increased. The high frequency components of this voltage are cut by R245, C229, C228, and R235 before being passed from pin 25 of Q207 via OP3 to pin 23 and the Q205 driver to drive the slide motor. TM2 is the slide motor servo on/off switch. Fast forward and fast rewinding of the slide motor can be achieved by switching TM5 and TM6 on and off for smoother accessing.

8. Spindle Motor Servo Circuit

CD playback is based on a CLV (Constant Linear Velocity) system where different rotational speeds are required at the start and end of the disc. The mechanism used to achieve constant linear velocity, consists of a PLL circuit for extracting clock signals from the playback EFM signal, and a servo circuit for controlling the motor on the basis of the clock signals.

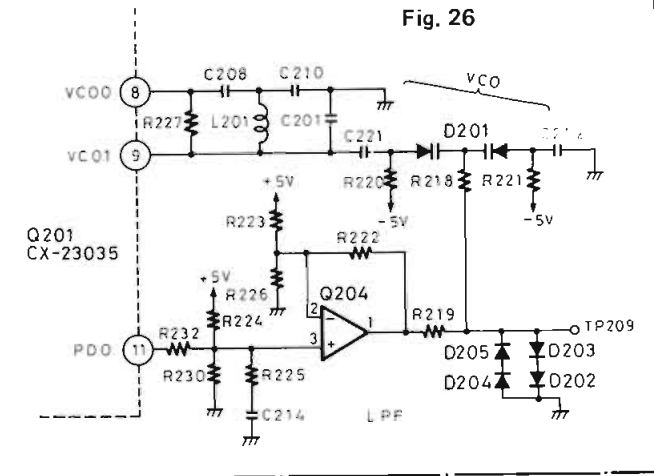

Fig. 26

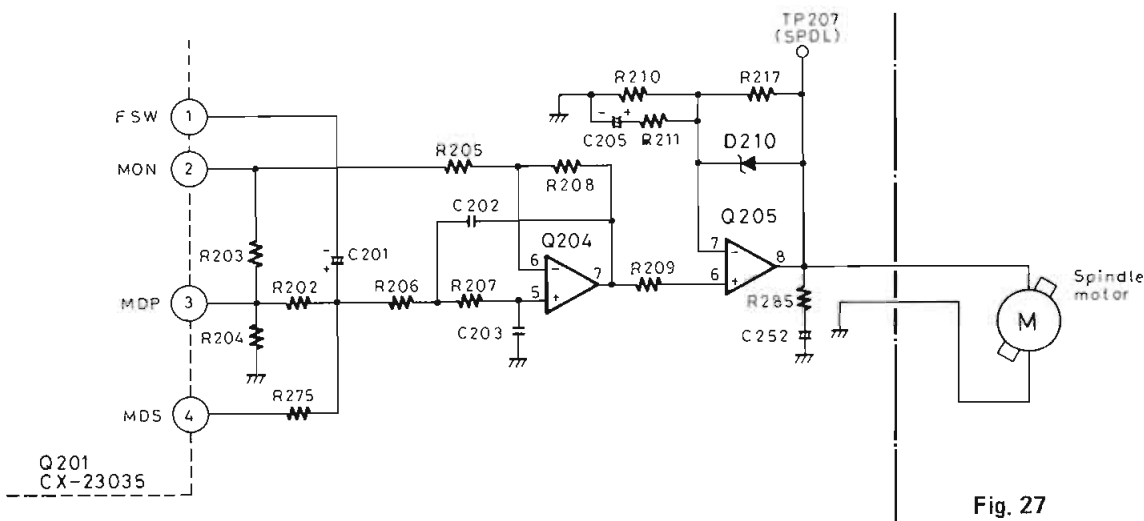

Fig. 27

8.1 PLL Circuit

This PLL circuit basically consists of an 8.6436MHz VCO (Voltage Controlled Oscillator), an LPF, and the Q201 phase comparator formed into a loop. The VCO oscillator output is divided in Q201 (4.3218MHz when locked) where the phase of the signal is compared with the edge of the EFM signal read from the disc. The comparator output PDO (pin 11 of Q201) is passed via the Q204 LPF back to the VCO.

When the PLL is locked, the L201 core is adjusted so that the VCO input VCOI (TP209) becomes 0V.

The GFS (TP202) is high when the PLL is locked.

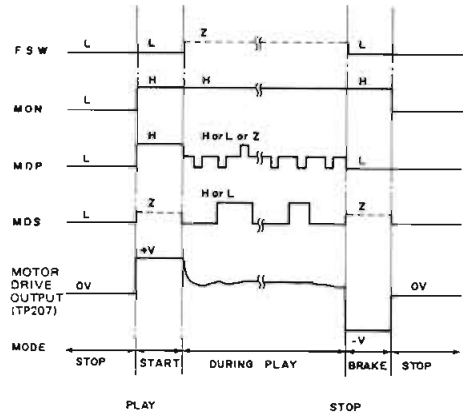

Fig. 28

8.2 Spindle Motor Circuit

The spindle motor control outputs are obtained from pins 1 thru 4 of Q201.

Pin 1 (FSW): Spindle motor time constant selector pin. This pin is switched to high impedance when the PLL is locked, and to low level when unlocked, thereby eliminating high frequency components.

Pin 2 (MON): Monitor on/off control output – on when high.

Pin 3 (MDP): Rough servo output when PLL is not locked, and phase control output when PLL is locked. The output is low in stop mode.

Pin 4 (MDS): Frequency control output when PLL is locked, and switched to high impedance when PLL is unlocked. The output is low in stop mode.

The waveform of each output is outlined in Fig. 28.

9. Tray Open/Close Circuit

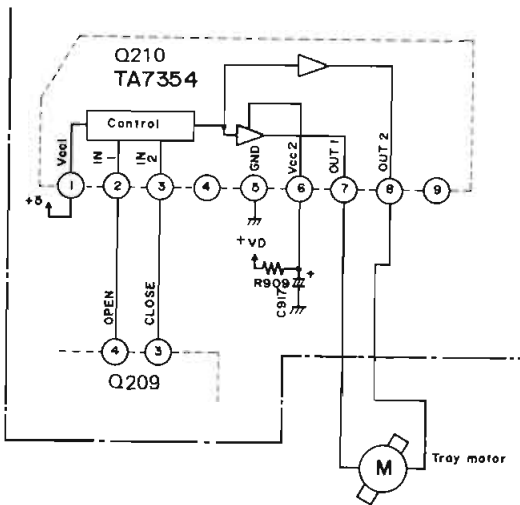

Fig. 29

Circuit used to control disc tray opening and closing operations. Control signals are passed direct from the Q209 microcomputer to pins 2 and 3 of the Q210 tray motor driver. In response the respective modes are determined by the outputs from pins 7 and 8 as indicated in Table 1.

IN1	IN2	OUT1	OUT2	MODE
1	1	L	L	STOP
1	0	H	L	CLOSE
0	1	L	H	OPEN

IN1 Pin 2 of Q210
 IN2 Pin 3 of Q210
 OUT1 Pin 7 of Q210
 OUT2 Pin 8 of Q210

Table 1

10. Microcomputer operation

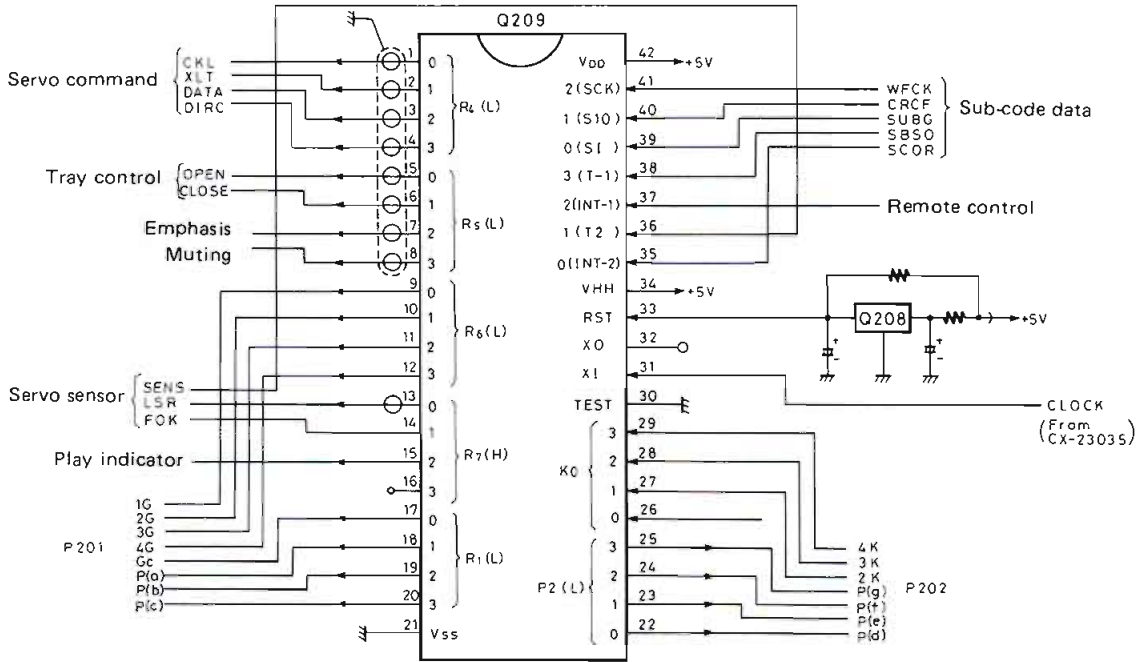

Fig. 30

11. Microcomputer and Peripheral Circuits

The microcomputer is C-MOS 4bit type. The respective roles are summarized below. Control of display, Key input processing, Control of servo system, Control of mechanical systems, Remote control operation, and Demodulation of sub-code.

11-1. Control of display and LED

Control of fluorescent display tube is used the dynamic drive method. The digit datas of five figures from I/O ports R6 (pins 9 thru 12) and output port P1 (pin 17) are output. The segment datas from output ports P1 (pins 18 thru 20) and P2 (pins 22 thru 25) are output. (See Fig. 31) The LED indicators are also driven in the same way using interval of digit Gc (pin 17).

11-2. Key Input Processing

A 18 (= 4 × 5-2) matrix is formed by using the digits in Fig. 31. Key input data is read by the K0 input ports (pin 26 thru 29). The condition of mechanical switches (S871, S881, and S891) is processed, and data of switches is read by the K1 input port (pin 26).

11-3. Control of Servo System

Focus, tracking, slide, and spindle servos for CX-20108 (Q207) and CX-23035 (Q201) are all operated by execution of instructions with serial data from Q209.

Serial data transfers involve DATA (pin 3), CLK (pin 1), XLT (pin 2), and DIRC (pin 4). Instruction address data and command data from the DATA pin is transferred when shifted by CLK trailing edges. That is the servo ICs Q201 and Q207 read data at CLK leading edges. Execution of instructions is commenced from XLT trailing edges (see Fig. 32). The DIRC pin is reserved specifically for instructions (such as one-track kick) requiring high speeds.

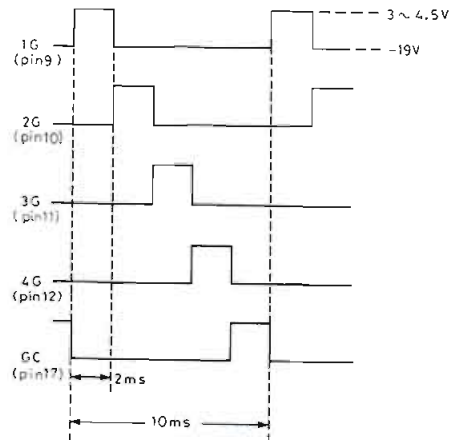

Fig. 31

10.4 Mechanical and Other Control Systems

(1) Laser On/Off

Optical pick-up laser on/off control output. Laser is on when the output is at low level.

(2) Muting Terminal

Audio muting control output for audio muting when the disc is stopped, and during accessing operations and pause mode. Muting is applied when the output is at high level.

(3) Emphasis Terminal

Automatic detection of disc pre-emphasis, and output of the audio de-emphasis control signal. Emphasis is switched on when the output is at high level.

(4) Sub-code Decoding

Decoding of sub-code data (apart from audio data) retrieved from the disc. These sub-codes include tracking numbers, index numbers, play time, total time, emphasis on/off, and the inter-tune signal. The inputs are listed below.

SUBQ (pin 39) . . . Sub-code Q signal serial data input. Data is shifted at **WFCK** trailing edges, and read by the microcomputer at leading edges.

WFCK (pin 41) . . SUBQ data shift clock. 7.35kHz when the PLL is locked.

SBSO (pin 2) . . . Sub-code P signal output. High when between tunes.

SCOR (pin 35) . . . Sub-code sink code output. 75Hz when PLL is locked.

CRCP (pin 1) . . . SUBQ input CRC checker pin. High level if SUBQ input data contains no error.

(5) Reset Circuit

Using an IC designed specifically for microcomputer resetting, a reset output (low level) is applied to the microcomputer **RST** terminal (pin 33) when +5V line voltage drops below the 4V reference voltage.

This pin is normally switched to low level temporarily when the power is switched on, and is subsequently kept at high level.

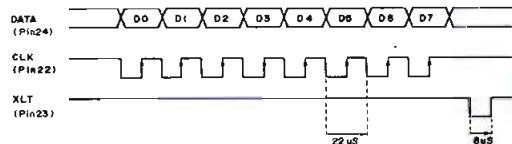

Fig. 32

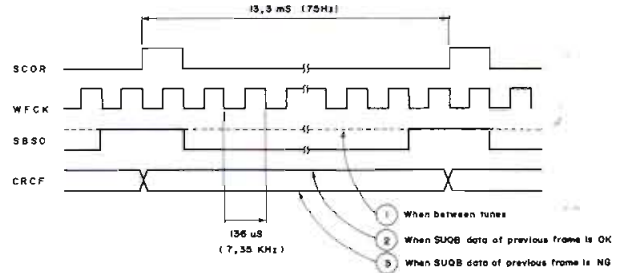

Fig. 33

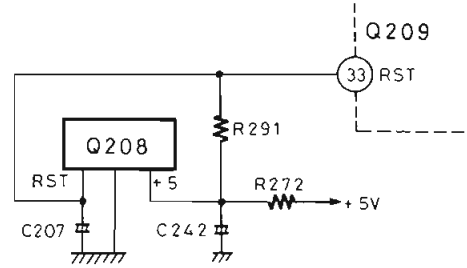

Fig. 34

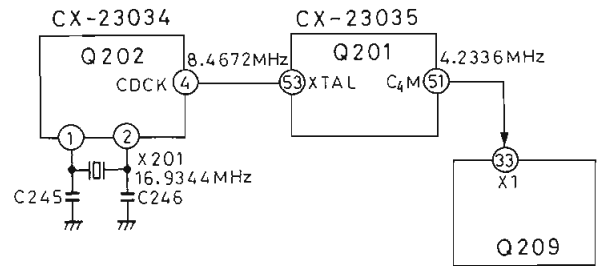

Fig. 35

(6) Clock Circuit

The microcomputer clock (4.23MHz) signal source is the over sampling filter (Q202). The clock is passed to the Processor (Q201). The clock is passed to the microcomputer via the route outlined in Fig. 35. If a failure occurs at any point along this route, system operation will come to a complete halt.

BLOCK DIAGRAM

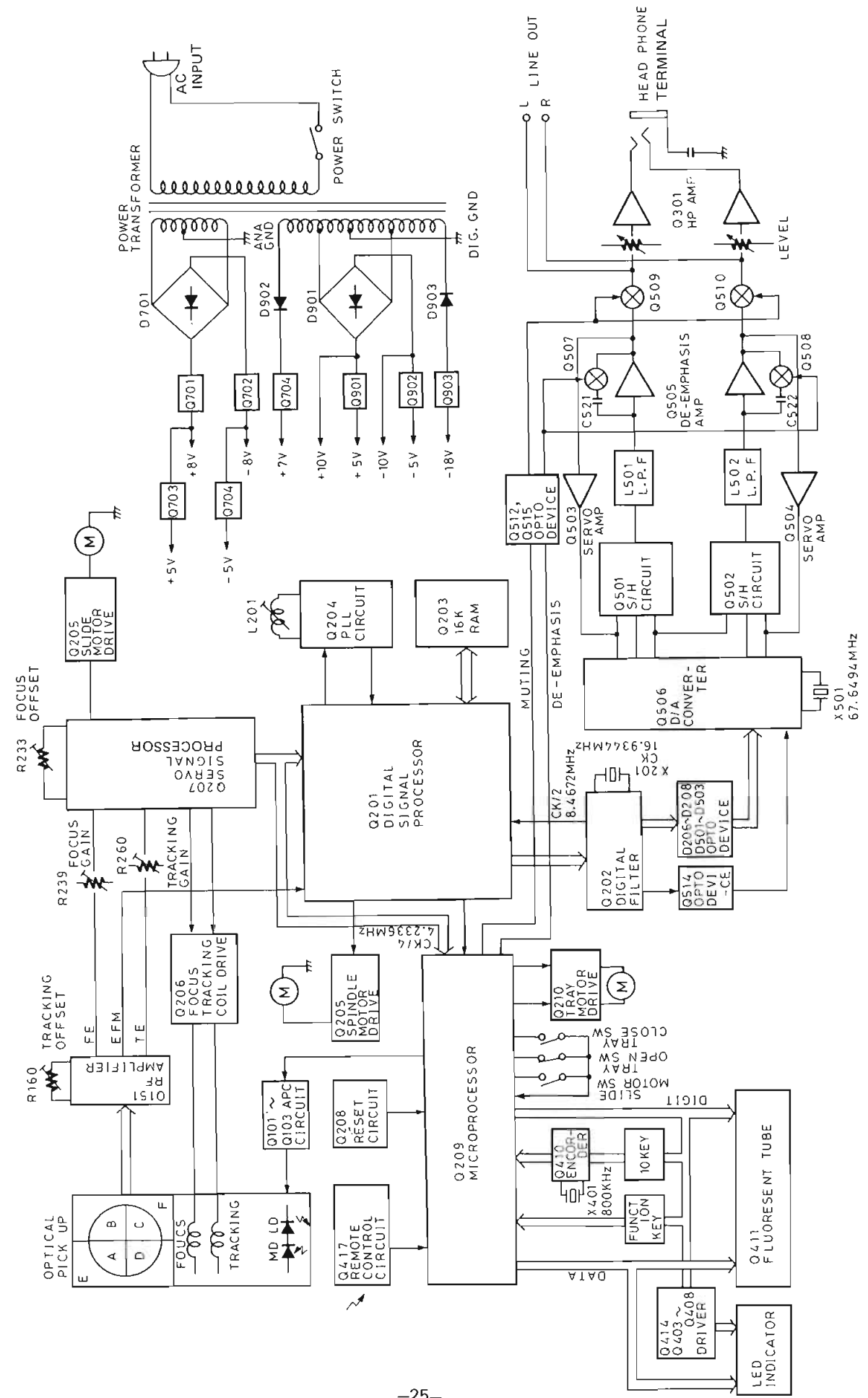

Fig. 36

BLOCK DIAGRAM OF IC

CX23035 (Digital Signal Processor)

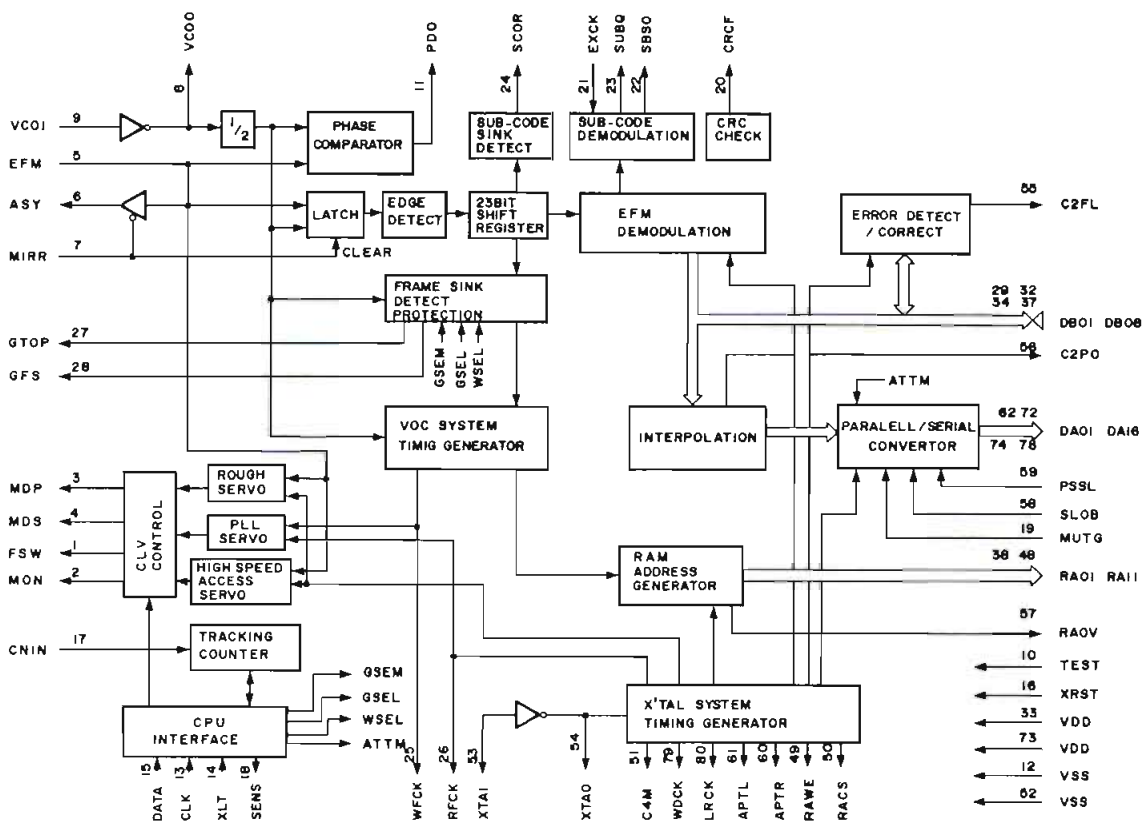
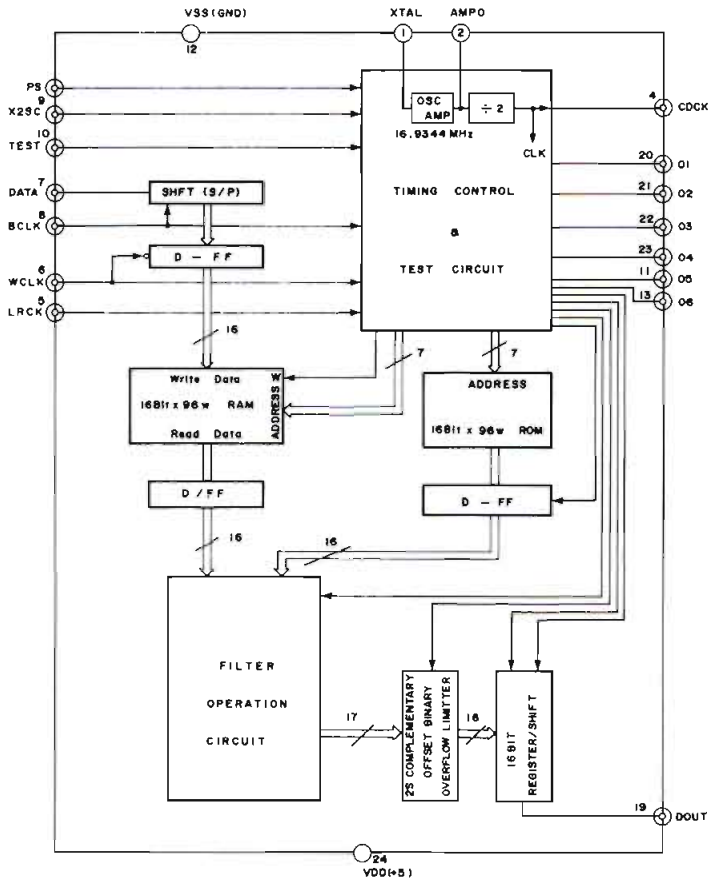

Fig. 37

1. Time const. selector output of output filter of spindle motor
2. ON/OFF control output of spindle motor
- 3/4. Drive output of spindle motor
5. EFM signal input from RF amp
6. Output to control slice level of EFM signal
7. Mirror input from RF amp
8. VCO output (8.6436MHz when lock)
9. VCO input
10. Test
11. Phase comparator output of EFM signal and VCO/2
12. Ground
13. Serial data transmit clock input from CPU
14. Latch input from CPU
15. Serial data input from CPU
16. System reset input (Reset at L)
17. Tracking pulse input
18. Output inside condition according address
19. Muting input
20. Output of CRC check of sub code Q
21. Clock input to serial output of sub code
22. Serial output of sub code
23. Sub code Q output
24. Sub code sink output (S0+S1)
25. Write frame clock output (7.35kHz when lock)
26. Read frame clock output (7.35kHz)
27. Frame synchronization protection condition indication output
28. Indication output of lock condition of frame sink
- 29 to 32. Data terminals of external RAM
33. Power supply (+5V)
- 34 to 37. Data terminals RAM
- 38 to 48. Address outputs of external RAM
49. Write enable signal output to external RAM.
50. Chip selector signal output to external RAM
51. 1/2 divided output (4.2336MHz)
52. Ground
53. X'tal oscillator input (8.4672MHz) from CX23034
54. X'tal oscillator output
55. Correction condition output
56. Indication output of pointer C2
57. Over and under indication output of RAM for jitter absorption of frame ± 4
58. Cord selector input of audio data output
59. Mode selector input of audio data output
60. Control output for aperture correction H when channel R
61. Control output for aperture correction H when channel L
- 62 to 72 and 74 to 78. Paraller audio outputs LSB (Pin 62) to MSB (Pin 78)
H when terminal PSSL (Pin 59)
Outputs when L
- 62 C1F1, 64 C1F2, 64 C2F1, 65 C2F2, 66 UGFS, 67 WFCK, 68 FCKV, 69 FCKX, 70 PLCK, 71 LRCK, 72 C4LR, 74 DENL, 75 DENR, 76 C210, 77 C210, and 78 DATA.
73. Power supply (+5V)
79. Strobe signal output (88.2kHz)
80. Strobe signal output (44.1kHz)

CX23034 (Over Sampling Filter)



1. Input for X'tal oscillator (16.9344MHz)
2. Output for X'tal oscillator
3. Input for test
4. Clock output (8.4672MHz)
5. Strobe input (44.1kHz)
6. Strobe input (88.2kHz)
7. Serial data input
8. Bit clock input
9. Input for selector of output form
10. Input for test
11. Timing signal
12. Ground
13. Timing signal
- 14 to 18. Test data outputs
19. Serial data output
- 20 to 23. Timing signals
24. Power supply (+5V)

Fig. 38

CX20152 (16-bit D/A converter)

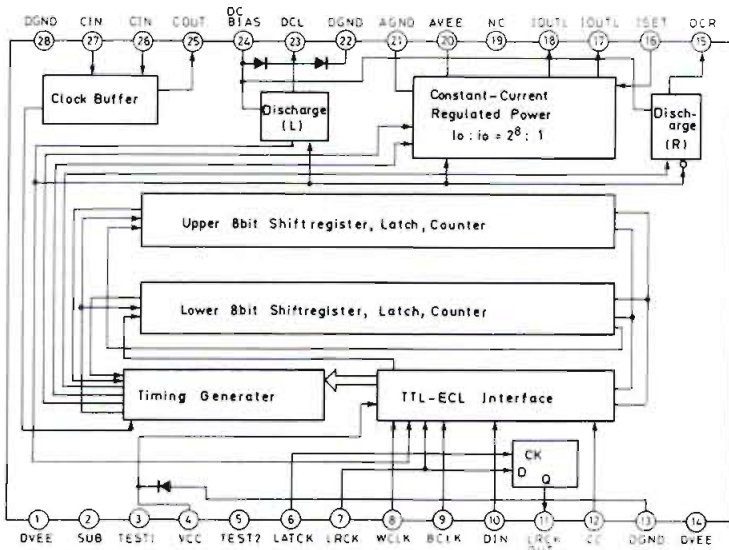
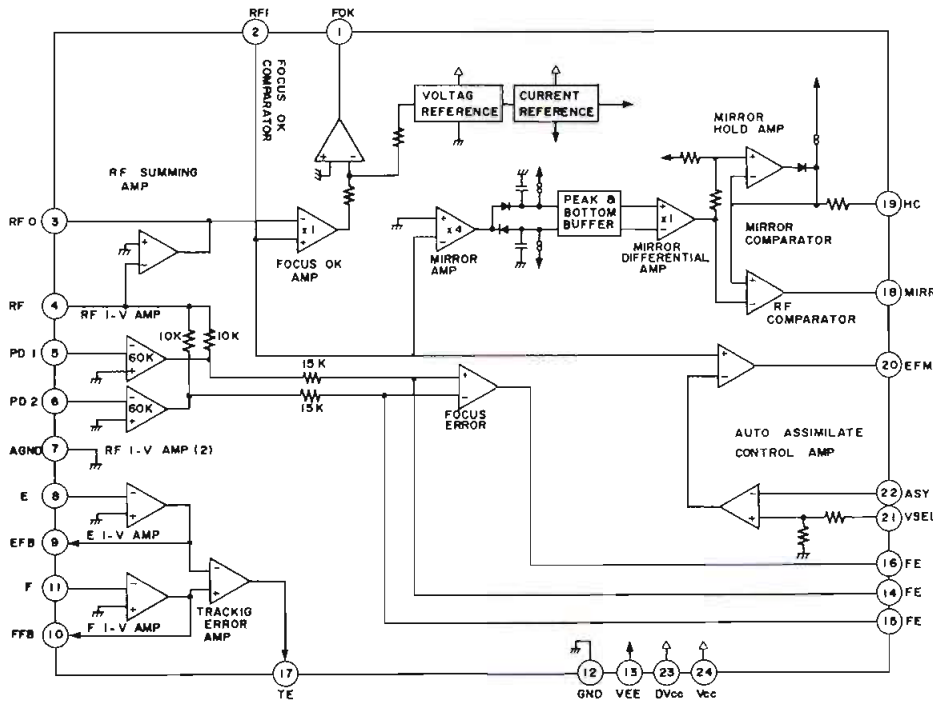

Fig. 39

CX20109 (RF Amplifier For CD)



NJM5532/4556/4558 (Operational Amplifier)

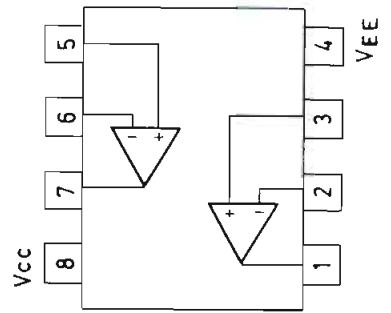

Fig. 41

Fig. 40

- | | |
|---|---|
| <ul style="list-style-type: none"> 1. Focus OK output 2. RF input 3. RF summing amp output 4. RF summing amp inversion input 5. RF I-V amp (1) inversion input 6. RF I-V amp (2) inversion input 7. Ground of small signal analog system 8. EI-V inversion input 9. EIV amp output 10. FIV amp output 11. FI-V amp inversion input 12. Ground | <ul style="list-style-type: none"> 13. Negative power supply 14. Focus error amp input 15. Focus error amp inversion input 16. Focus error amp output 17. Tracking error amp output 18. Mirror output comparator output (Active at H) 19. Mirror hold capacitor connection terminal 20. EFM output comparator output 21. Terminal for reference input level setting of auto assimilate control amp 22. Auto assimilate control input 23. EFM comparator system power supply 24. Positive power supply |
|---|---|

HM6116FP-4 (CMOS RAM)

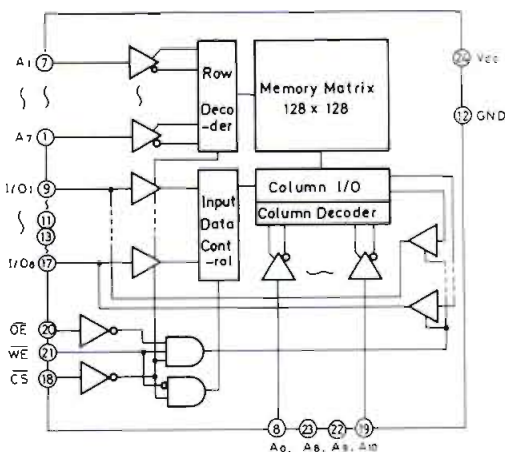

Fig. 42

TA7256 (Operational Amplifier)

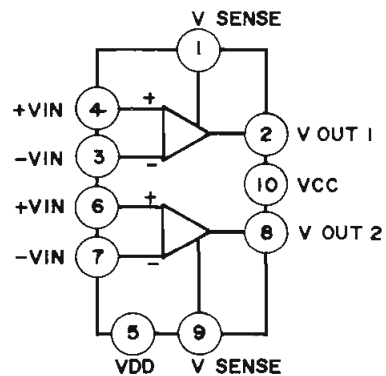
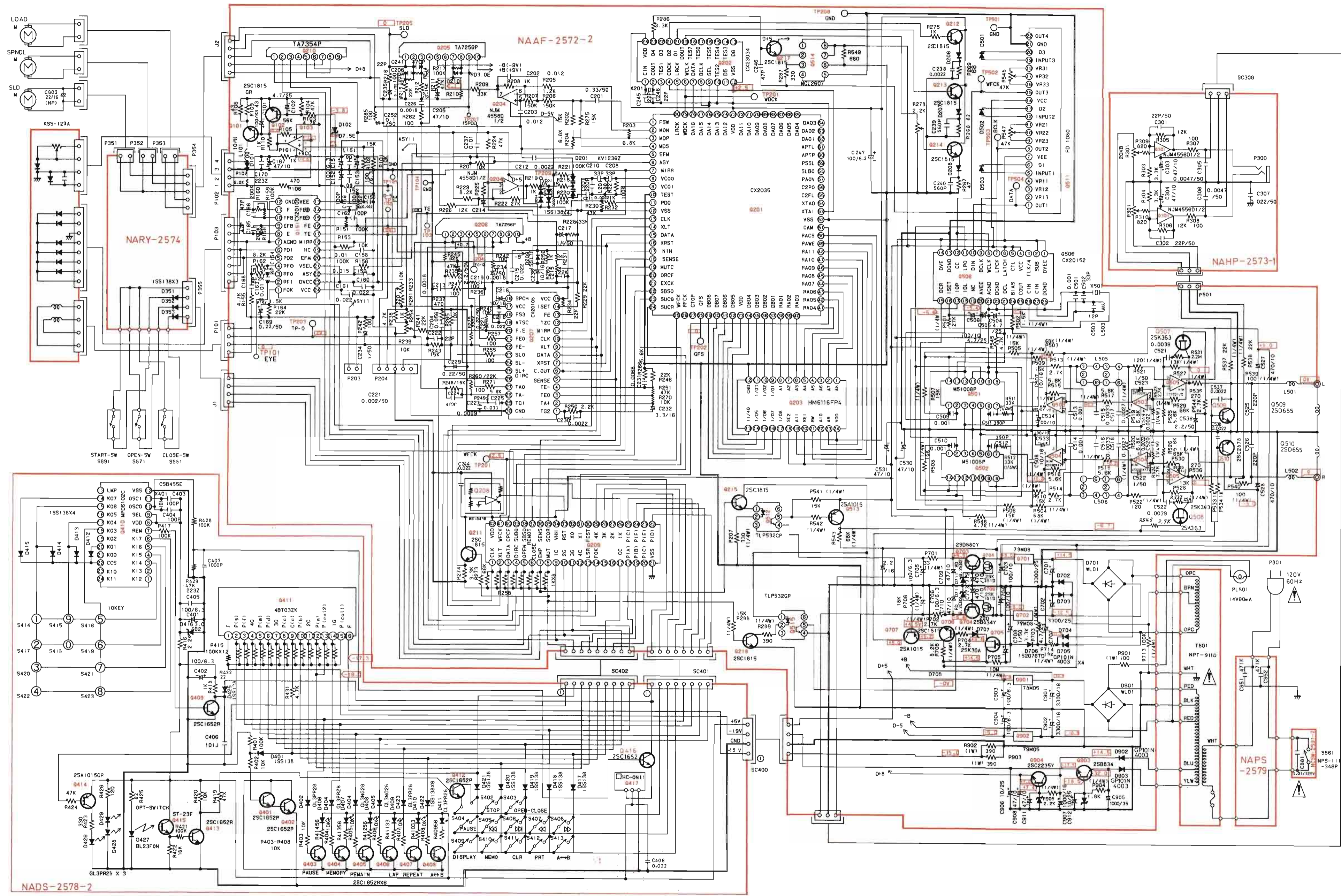

Fig. 43

SCHEMATIC DIAGRAM



CX20108 (Servo Signal Processor)

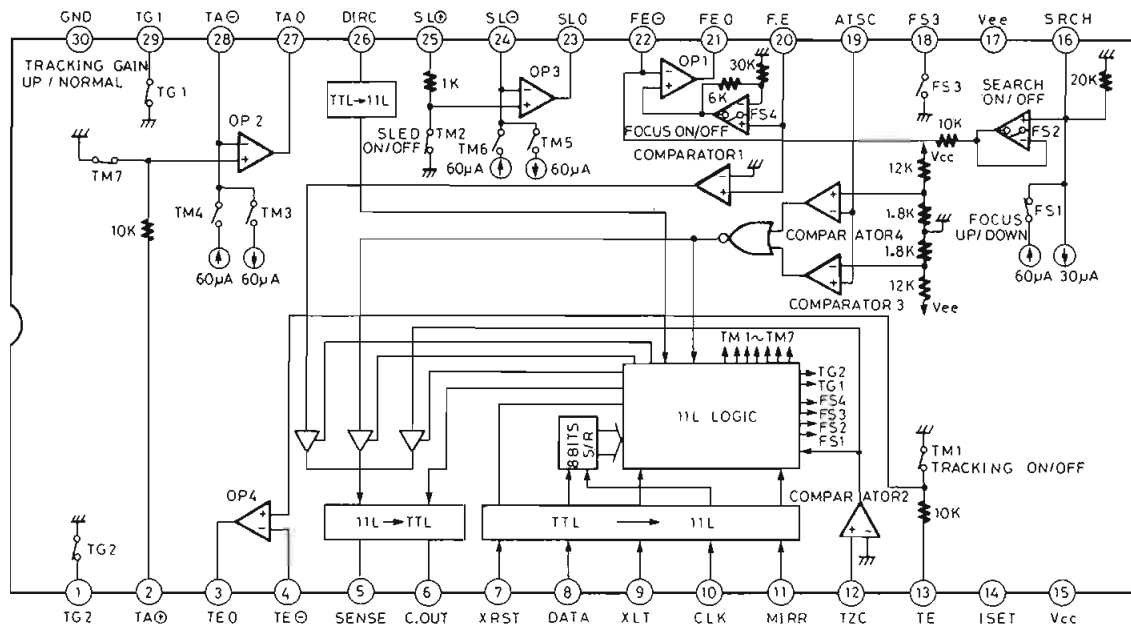

Fig. 44

1. Terminal for tracking amp gain selector
2. Input of operation amp 2
3. Output of operation amp 4
4. Inversion input of operation amp 4
5. Output of SSP inside condition
6. Signal output for track number count when high speed access
7. Clear input of inside register
8. Serial data transmit from CPU to SSP
9. Serial data latch from CPU to SSP (Active low)
10. Serial data transmit clock from CPU to SSP (Read data at trailing edge)

11. Mirror signal input from RF amp
12. Tracking signal error input via capacitor
13. Tracking error signal input
14. Setting of current value made a decision about focus search, tracking jump, and sled voltage
15. Power supply (+5V)
16. Connect the capacitor
17. Power supply (-5V)
18. Focus amp gain selector terminal
19. Input information (Mechanical shock)
20. Focus error signal input
21. Operation amp 1 output
22. Operation amp 1 inversion input
23. Operation amp 3 output
24. Operation amp 3 inversion input
25. Operation amp 3 input
26. Use when jump one track
27. Operation amp 2 output
28. Operation amp 2 inversion output
29. Tracking amp gain selector terminal
30. Ground

4-BT-03ZK (Fluorescent Display Tube)

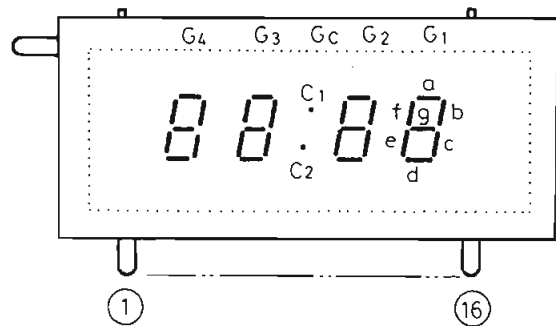

Fig. 45

PIN NO.	1	2	3	4	5	6	7	8	9	10	11	12	13	14	15	16
CONNECTION	F	g	f	G ₄	e	d	G ₃	c	G _c	b	G ₂	a	c ₂	G ₁	c ₁	F

μ PD6102G (Signal Converter)

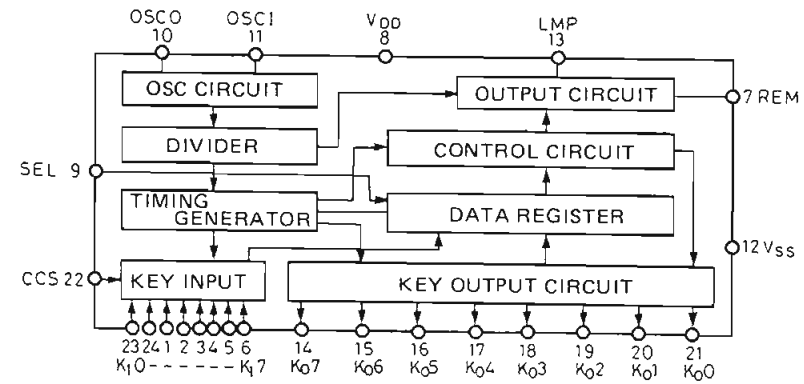

Fig. 46

- | | |
|---|---|
| 1. K ₁ , 2 Key Input 2 | 13. LMP Lamp Output |
| 2. K ₁ , 3 Key Input 3 | 14. K ₀ , 7 Key Output 7 |
| 3. K ₁ , 4 Key Input 4 | 15. K ₀ , 6 Key Output 6 |
| 4. K ₁ , 5 Key Input 5 | 16. K ₀ , 5 Key Output 5 |
| 5. K ₁ , 6 Key Input 6 | 17. K ₀ , 4 Key Output 4 |
| 6. K ₁ , 7 Key Input 7 | 18. K ₀ , 3 Key Output 3 |
| 7. REM Remote Output | 19. K ₀ , 2 Key Output 2 |
| 8. VDD Power supply | 20. K ₀ , 1 Key Output 1 |
| 9. SEL 64/128 Data Select | 21. K ₀ , 0 Key Output 0 |
| 10. OSCO Oscillator Output | 22. CCS Custom Code Select Input |
| 11. OSC1 Oscillator Input | 23. K ₁ , 0 Key Input 0 |
| 12. VSS | 24. K ₁ , 1 Key Input 1 |

FD1080 (Optical Conveyance)

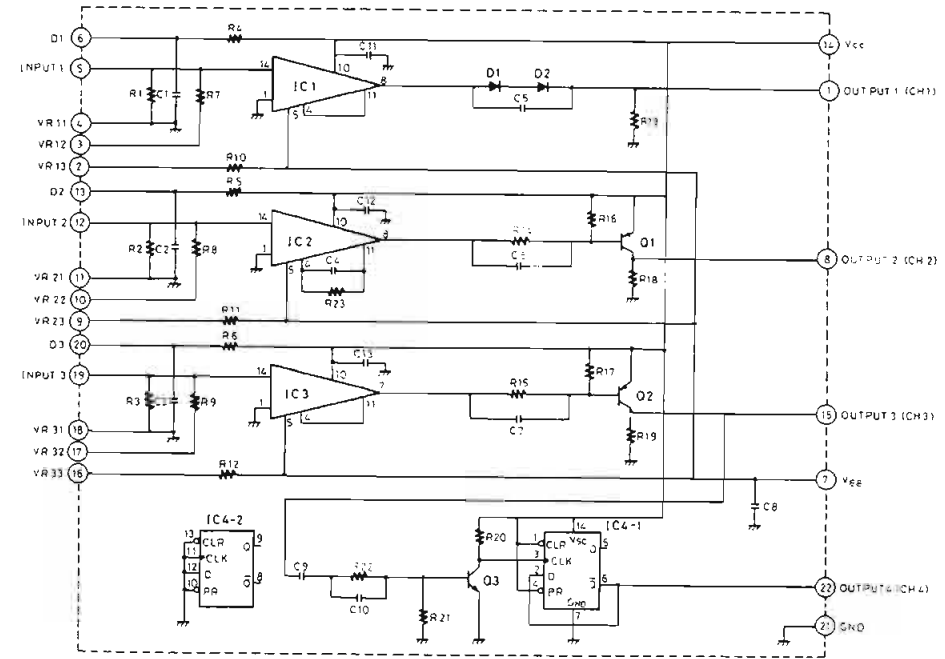

Fig. 47

TA7354P (Motor Drive)

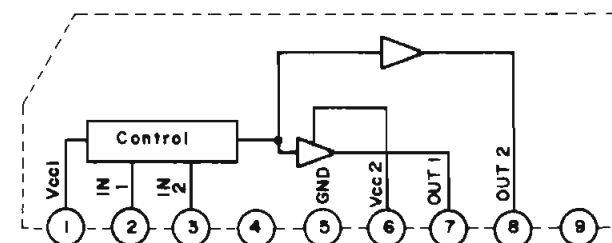

Fig. 48

TMP47C410N (4-Bit Microcomputer)

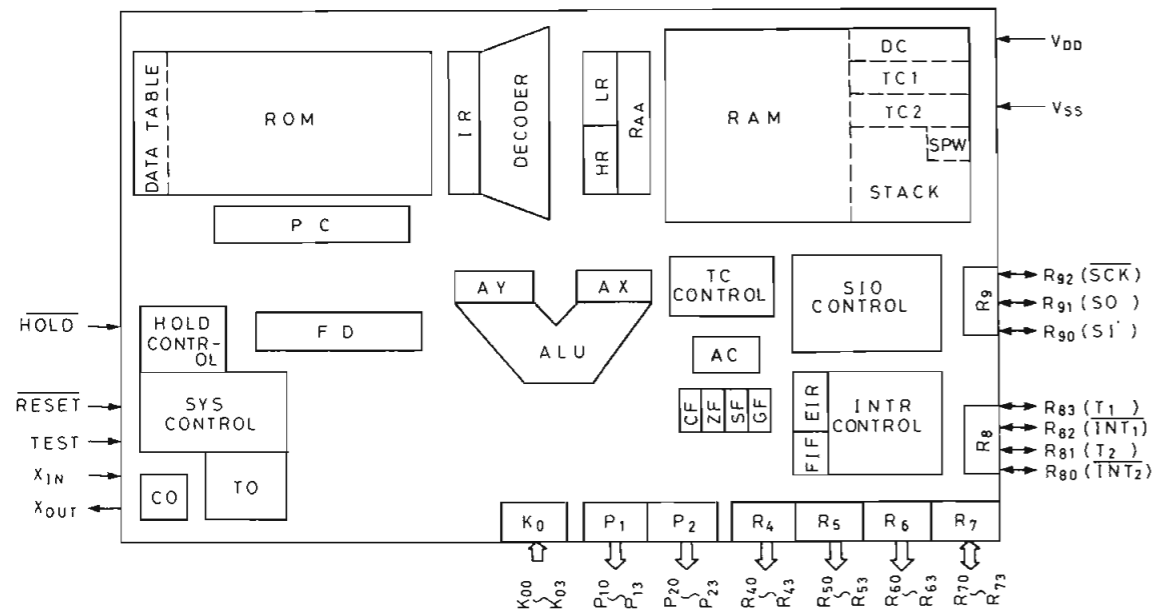
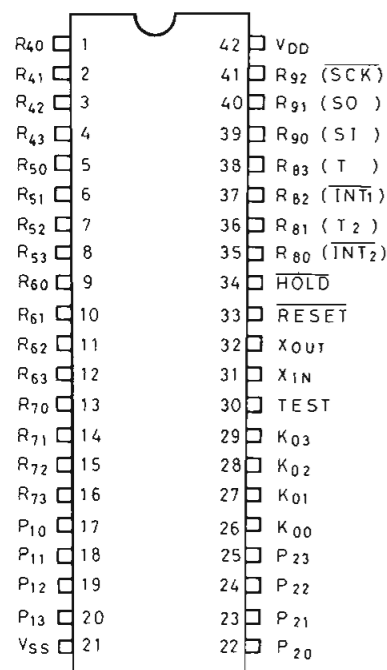

Fig. 49



Terminal	I/O	Function
K03 ~ K00	Input	Input port
P13 ~ P10	Output	Output port (PLA match, high voltage output)
P23 ~ P20	Output	Output port (PLA match, high voltage output)
R43 ~ R40	Output	Output port (high voltage output)
R53 ~ R50	Output	Output port (high voltage output)
R63 ~ R60	Output	Output port (high voltage output)
R73 ~ R70	I/O	Input/output port
R83 (T1)	I/O	Input/output port or timer/counter input
R82 (INT1)	I/O	Input/output port or interruption input
R81 (T2)	I/O	Input/output port or timer/counter input
R80 (INT2)	I/O	Input/output port or interruption input
R92 (SCK)	I/O	Input/output port or serial port
R91 (SO)	I/O	Input/output port or serial output
R90 (SI)	I/O	Input/output port or serial input
XIN, XOUT	Input, Output	Connect to the oscillator
RESET	Input	Initialize input
HOLD	Input	Hold signal input
TEST	Input	Low level or open
VDD	Power supply	+5V
VSS	Power supply	0V

ADJUSTMENT PROCEDURES

Instruments Required

Frequency counter, CR Oscillator, Oscilloscope, Test disc (SONY YEDS-18 <TYPE 4>), Amplifier, Jig 2 or Filter, Shorting clip.

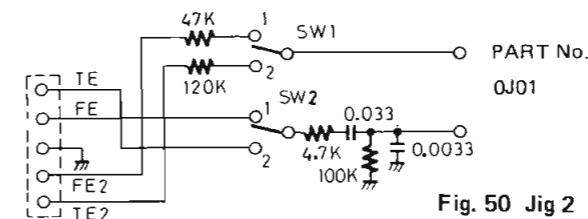

1. CLV-PLL circuit adjustment

1. Turn the power switch to ON.
2. With set in STOP condition, use the shorting clip to drop TP209 (VCOI) to ground.
3. Connect the frequency counter to TP201 (WFCK).
4. Turn the oscillator coil L201 to adjust frequency to 7.35 ± 0.01 kHz.
5. Remove the shorting clip.

2. Focus and tracking adjustments

2-1. Adjustment method 1 (When adjustment jig 2 is used)

- Set the semi-fixed resistors R160, R233, R239, R260 to about their midpoint.
- Carry out adjustment the Track 1. Take sufficient care to avoid damage.

2-1-1. Focus offset adjustment

1. Connect the DC voltmeter and channel 1 on the oscilloscope to terminal TP-102 (F.E).
2. Connect the channel 2 on the oscilloscope to terminal TP-101 (Eye). Play the track 2 of test disc. Set the synchronization of oscilloscope to channel 2.
3. With terminal FE within the range of 0 ± 0.25 V, observe the waveform on the oscilloscope, and adjust R233 for the least jitter.
- When the amount of jitter is broad, adjust F.E to 0V.
4. When adjustment, disconnect the oscilloscope.

2-1-2. Focus gain adjustment

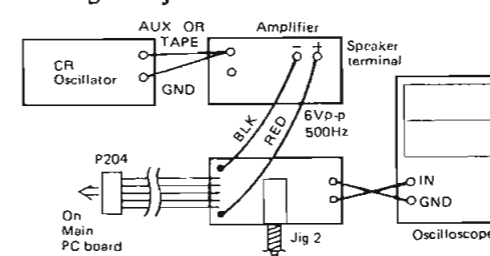

1. Apply a sine wave 6Vp-p at 500Hz from the CR oscillator to red wire of adjustment jig 2.
2. Connect the oscilloscope to terminal of adjustment jig 2.
3. Push the switch of adjustment jig 2 to on.
4. Adjust R239 so that there is a sine wave of 1Vp-p on the oscilloscope.
5. After adjustment, disconnect the CR oscillator.

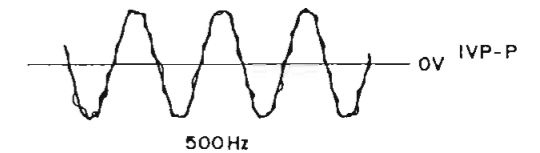
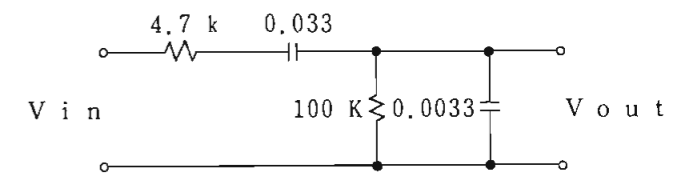

Fig. 53

2-1-3. Tacking offset adjustment

1. Set the semi-fixed resistor R260 to minimum. (Completely counterclockwise.)
2. Connect the oscilloscope to TP103 (T.E).
3. Adjust the semi-fixed resistor R160 so that the waveform deflection at T.E is 0V at the center.

NOTE: 1. When the disc rotates at high speed, make the adjustment while holding down the speed manually.
2. An adjusting rod of insulating material must be used.

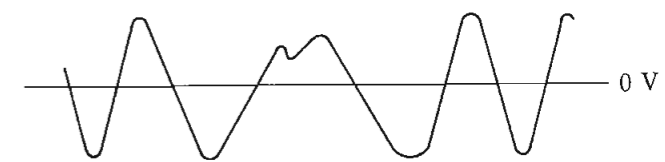

Fig. 54

2-1-4. Tracking gain adjustment

1. Return R260 to about the center, and confirm that the servo is operating.
2. Connect the oscillator and oscilloscope to adjustment jig 2. (See Fig. 52)
3. Push the switch of adjustment jig 2 to off.
4. In the same manner as that of 2-1-2, adjust R260 so that a sine wave of 1Vp-p appears on the oscilloscope.

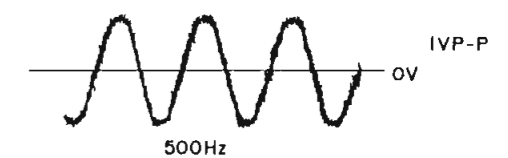

Fig. 55

2. Focus and tracking adjustments

2-2. Adjustment method 2 (When filter is used)

- Set the semi-fixed resistors R160, R233, R239, R260 to about their midpoint.
- Carry out adjustment the Track 1. Take sufficient care to avoid damage.

2-1-1. Focus offset adjustment

1. Connect the DC voltmeter and channel 1 on the oscilloscope to terminal TP-102 (F.E).
2. Connect the channel 2 on the oscilloscope to terminal TP-101 (Eye). Play the track 2 of test disc. Set the synchronization of oscilloscope to channel 2.
3. With terminal FE within the range of $0 \pm 0.25V$, observe the waveform on the oscilloscope, and adjust R233 for the least jitter.
- When the amount of jitter is broad, adjust F.E to OV.
4. When adjustment, disconnect the oscilloscope.

2-2-2. Focus gain adjustment

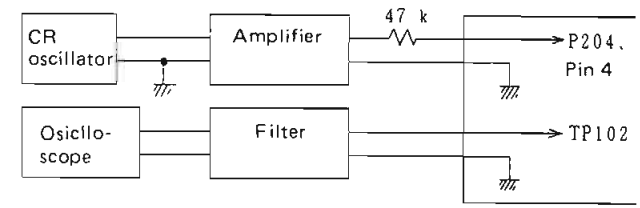

Fig. 55 Connection of instrument

1. Apply a sine wave 6Vp-p at 500Hz from the CR oscillator to pin 4 of P204 of unit.
2. Connect the oscilloscope to filter output and the filter input to terminal TP102 (F.E).
3. Adjust R239 so that there is a sine wave of 1Vp-p on the oscilloscope. (See Fig. 53)
4. After adjustment, disconnect the CR oscillator.

2-2-3. Tacking offset adjustment

1. Set the semi-fixed resistor R260 to minimum. (Completely counterclockwise.)
2. Connect the oscilloscope to TP103 (T.E).
3. Adjust the semi-fixed resistor R160 so that the waveform deflection at T.E is OV at the center. (See Fig. 54)

Note: 1. When the disc rotates at high speed, make the adjustment while holding down the speed manually.
2. An adjusting rod of insulating material must be used.

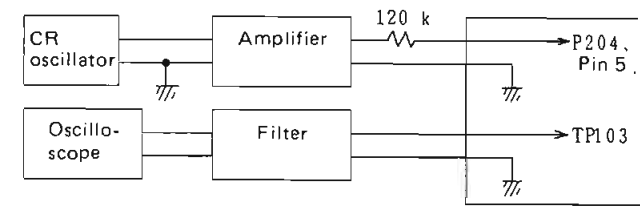

Fig. 57

2-2-4. Tracking gain adjustment

1. Return R260 to about the center, and confirm that the servo is operating.
2. Connect the oscillator and oscilloscope as shown fig. 57.
3. In the same manner as that of 2-2-2, adjust R260 so that a sine wave of 1Vp-p appears on the oscilloscope. (See Fig. 55)

3. Optical coupling adjustment

- Set the semi-fixed resistors R278, R547 and R548 to maximum. (completely clockwise.)

3-1. BCLK adjustment

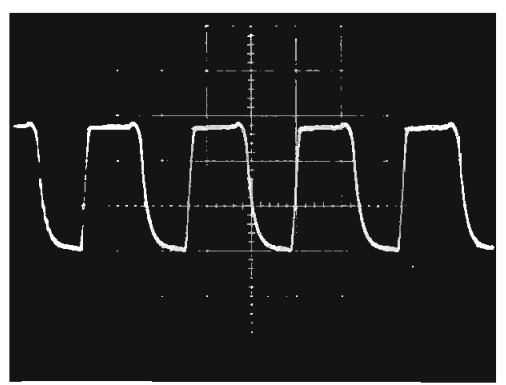

Photo 5

1. Connect the oscilloscope to terminal TP-503.
2. The rise of the BCLK pulse width can be adjusted to 140ns using R547. (Point: DC 2V)

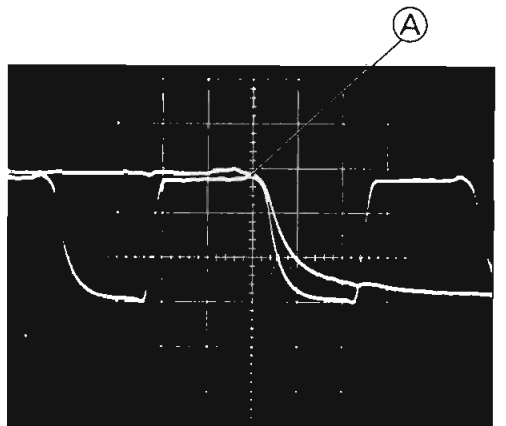

Photo 6

1. Connect the oscilloscope to Terminal TP-502.
2. Make a rough adjustment to about 50% duty ratio.
3. Match the fall of BCLK and WCLK to the point marked A using R548.

3-3. DATA adjustment

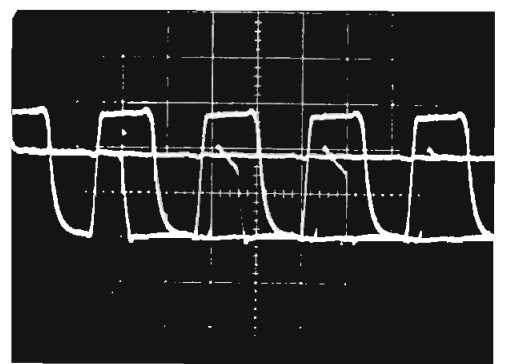

Photo 7

1. Connect the oscilloscope to terminal TP504.
2. Adjust the width of the C DATA to 50 ~ 60ns using R278.
3. Check the margin of the rise of BCLK and DATA. $B \geq 20ns$

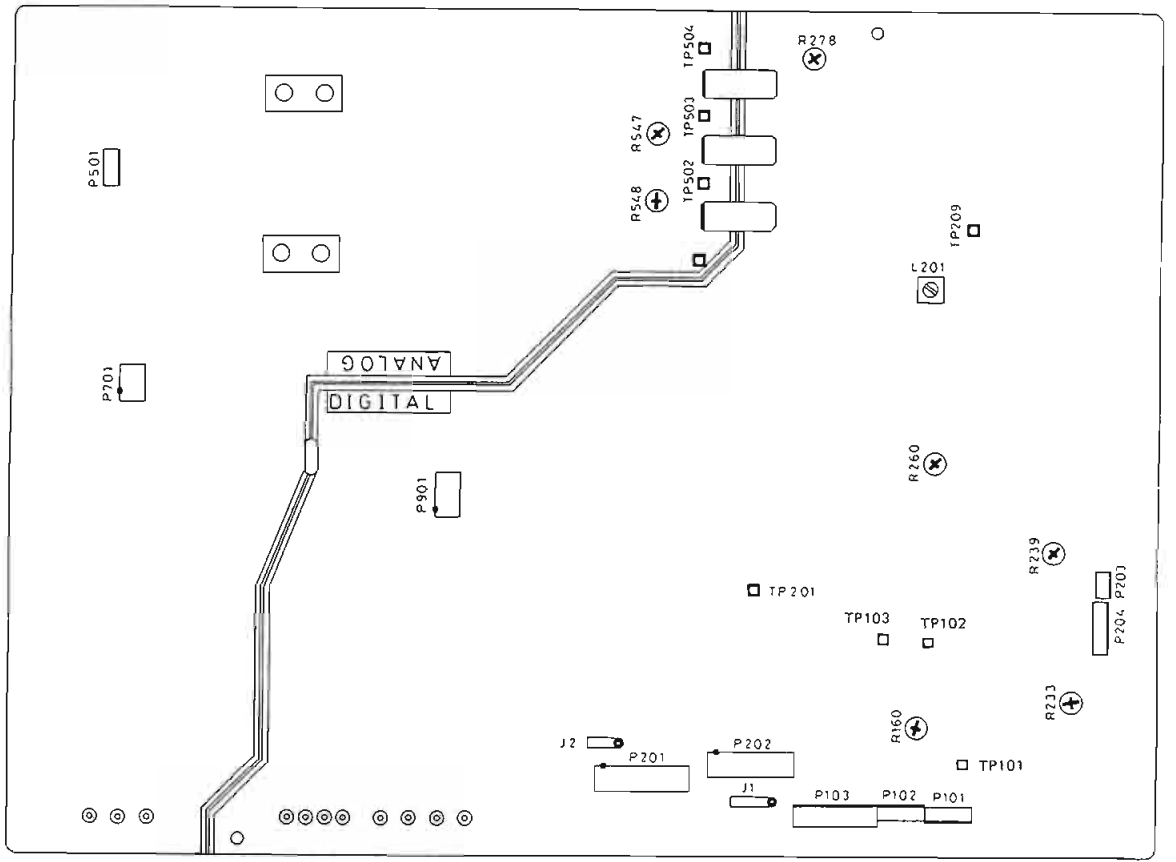
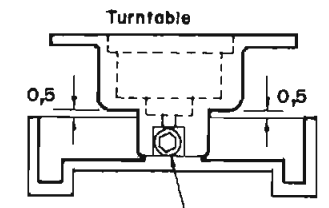

Fig. 60 Adjustment Point

Mechanism Adjustment

• Turntable height adjustment

Adjust the screw A to make the gap between turntable and chassis M 0.5mm.



1.25mm Hexagonal wrench

Fig. 58

• Close switch PC board attachment

Attach the close switch PC board ass'y (NACS-2576) to completely arrow mark.

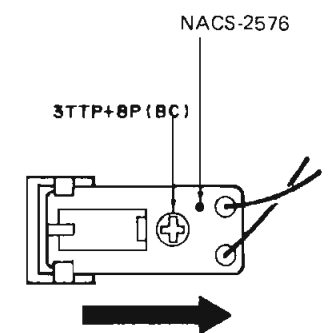

Fig. 59

PRINTED CIRCUIT BOARD VIEW FROM BOTTOM SIDE

Main circuit pc board

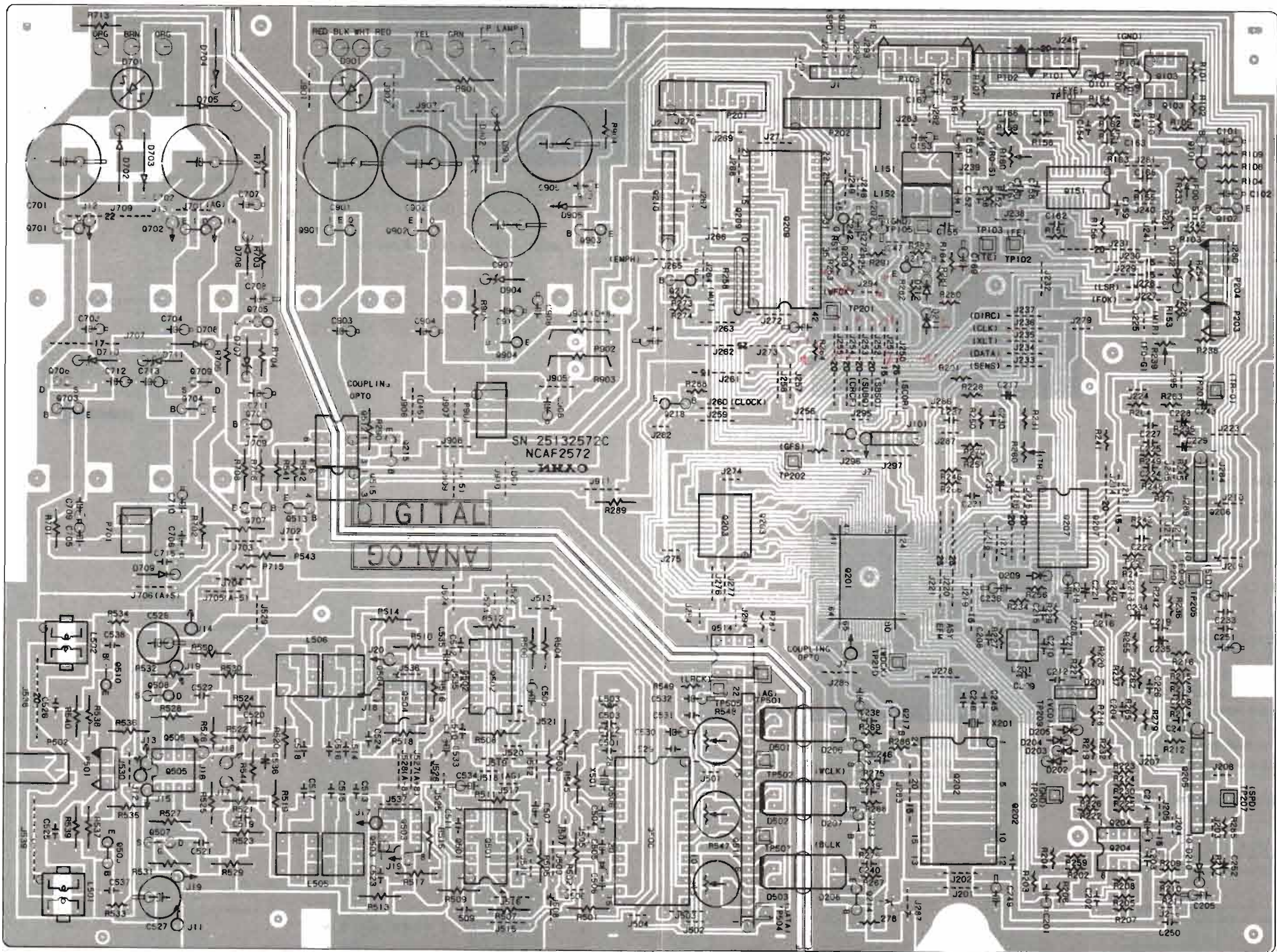

Fig. 61

PRINTED CIRCUIT BOARD-PARTS LIST

MAIN CIRCUIT PC BOARD (NAAF-2572-2)

CIRCUIT NO.	PART NO.	DESCRIPTION
ICs		
Q103	222465	NJM4558D
Q151	222886	CX20109
Q201	222881	CX23035
Q202	222880	CX23034
Q203	222882	HM6116FP-4
Q204	222465	NJM4558D
Q205, Q206	222825	TA7256P
Q207	222875	CX20108
Q208	222951	M51943B
Q209	222961	TMP47C410N-6075Z
Q210	222826	TA7354P
Q501, Q502	22240001	M51008P (1)
Q503, Q504	222585	NJM4558DXB
Q505	222949	NJM5532D
Q506	222883	CX20152
Q511	222053	FD1080
Q512, Q515	2252173	TLP532(GR)
Q514	226026	MCL2601
Q701	222780082	78M08
Q702	222790082	79M08
Q901	222780052	78M05
Q902	222790052	79M05
Transistors		
Q101	2211654	2SC2235(Y)
Q102	2211255	2SC1815(GR)
Q211-Q215	2211255	2SC1815(GR)
Q217, Q218	2211255	2SC1815(GR)
Q507, Q508	2212526	2SK363(V), FET
Q509, Q510	2211706	2SD655(F)
Q513	2211455	2SA1015(GR)
Q703	2201074	2SD880(Y)
Q704	2201244	2SB834(Y)
Q705	2212375	2SK30ATM(GR), FET
Q706	2211255	2SC1815(GR)
Q707	2211455	2SA1015(GR)
Q708, Q709	2212304	2SK381(D)
Q903	2201244	2SB834(Y)
Q904	2211654	2SC2235(Y)
Diodes		
D101	223155	1SS138
D102	2239533	RD7.5EB3
D201	223157	KV1236Z, Variable capacitor
D202-D205	223155	1SS138
D206	225225	PCON-01(B), Photo copula
D207, D208	225224	PCON-01(A), Photo copula
D209	223155	1SS138
D210	2242602	RD3.0EB2, Zener
D701	223890 or 223862	W01-RL or WL-01
D702-D705	223880	GP101N4003
D706	223145 or 223150	1S2076TD or US1040
D707	2239472	RD5.6EB2, Zener
D710, D711	2239492	RD6.2EB2, Zener
D901	223890 or 223862	W01-RL or WL-01

CIRCUIT NO.	PART NO.	DESCRIPTION
Diodes		
D902, D903	223880	GP101N4003
D904	2239533	RD7.5EB3, Zener
D905	2239732	RD20EB2, Zener
Coils		
L101	231023	NCH1062
L151, L152	231054	NCH5095
L201	232122	NSO4038
L501, L502	231066	NCH1118
L503	233345	NCH1115
L505, L506	232127	NMC-6055
X'tals		
X201	3010107	KD6209F-A
X501	3010102	KD5716FAA
Capacitors		
C101	352721019	100µF, 6.3V, Elect.
C102	352750479	4.7µF, 25V, Elect.
C151-C153	352721019	100µF, 6.3V, Elect.
C167	352734709	47µF, 10V, Elect.
C169	352784799	0.47µF, 50V, Elect.
C201	352783399	0.33µF, 50V, Elect.
C205	352734709	47µF, 10V, Elect.
C207	352741009	10µF, 16V, Elect.
C214	352780109	1µF, 50V, Elect.
C217	352980106	1µF, 50V, Non-polar elect.
C218	352741009	10µF, 16V, Elect.
C221, C229	352982296	0.22µF, 50V, Non-polar elect.
C228	352940226	2.2µF, 16V, Non-polar elect.
C232	352980336	3.3µF, 50V, Non-polar elect.
C234, C235	352981096	0.1µF, 50V, Non-polar elect.
C236	352741009	10µF, 16V, Elect.
C242	352780109	1µF, 50V, Elect.
C243	352981096	0.1µF, 50V, Non-polar elect.
C247	352721019	100µF, 6.3V, Elect.
C252	352981099	0.1µF, 50V, Non-polar elect.
C504, C505	352750479	4.7µF, 25V, Elect.
C506	352721019	100µF, 6.3V, Elect.
C507, C508	352741009	10µF, 16V, Elect.
C509, C510	372551524	1500pF±5%, 250V, Styrole
C511, C512	372523914	390pF±5%, 50V, Styrole
C523, C524	352980106	1µF, 50V, Non-polar elect.
C525, C526	372522214	220pF±5%, 50V, Styrole
C527, C528	3500095	470µF, 10V, Elect.
C530, C532	352734709	47µF, 10V, Elect.
C533, C534	352731019	100µF, 10V, Elect.
C535	352734709	47µF, 10V, Elect.
C536	352940226	2.2µF, 16V, Non-polar elect.
C701, C702	352753329	3300µF, 25V, Elect.
C703, C704	352731019	100µF, 10V, Elect.
C705, C706	352721019	100µF, 6.3V, Elect.
C707	352750479	4.7µF, 25V, Elect.
C708	352780109	1µF, 50V, Elect.
C709, C710	352734709	47µF, 10V, Elect.
C711	372522224	2200pF±5%, 50V, Styrole
C712	352731019	100µF, 10V, Elect.
C713	352741009	10µF, 16V, Elect.
C901, C902	352743329	3300µF, 16V, Elect.
C903, C904	352721019	100µF, 6.3V, Elect.
C905	352764719	470µF, 35V, Elect.
C906	352751009	10µF, 25V, Elect.
C907	352744719	470µF, 16V, Elect.
C908	352734709	47µF, 10V, Elect.
C909, C910	352721019	100µF, 6.3V, Elect.

CIRCUIT NO.	PART NO.	DESCRIPTION
C911	352734709	47µF, 10V, Elect.
C912	352751009	10µF, 25V, Elect.
C913	379121124	1100pF±5%, 50V, Plastic
Resistors		
R160	5210072	N06HR220KBD, Semi-fixed
R233	5210058	N06HR1KBD, Semi-fixed
R239	5210064	N06HR10KBD, Semi-fixed
R258	49163102408	1kohm × 8, 1/10W, Network
R260	5210066	N06HR22KBD, Semi-fixed
R278	5210009	N06HR2.2KBD, Semi-fixed
R547, R548	5210068	N06HR47KBD, Semi-fixed
R705	431421065	10Mohm, 1/4W, Solid
R901	441621014	100ohm, 1W, Metal oxide film
R902, R903	441623914	390ohm, 1W, Metal oxide film
Plugs		
P101, P102	25055134	NPLG-4P118
P103	25055138	NPLG-8P112
P203	25055132	NPLG-2P116
P204	25055135	NPLG-2P119
P501	25055133	NPLG-3P117
Sockets		
P201	25050273	NSCT-9P101
P202	25050272	NSCT-8P100
P901	25050268	NSCT-4P96
P701	25050267	NSCT-3P95
SC201	2000533	NSAS-5P498
SC202	2000532	NSAS-4P488
Terminal		
P502	25045190	NPJ-2PDBL74
Radiators		
	27160029	RAD-07
Screws		
	82143006	3P+6 FN(BC), Pan head
Shielded plate		
	27150216	
Rivert		
	880009	

HEADPHONE TERMINAL PC BOARD (NAHP-2573-2)

CIRCUIT NO.	PART NO.	DESCRIPTION
IC		
Q301	222654	NJM4556D
Capacitors		
C303, C304	353734709	47µF, 10V, Elect.
Resistor		
R301	5104172A	N09RGL20KB15, Variable
Terminal		
P301	25045152	HLJ054-01-010-BLK, Headphone
Socket		
SC303	2000588	NSAS-3P-544

HEADPHONE AMPLIFIER PC BOARD

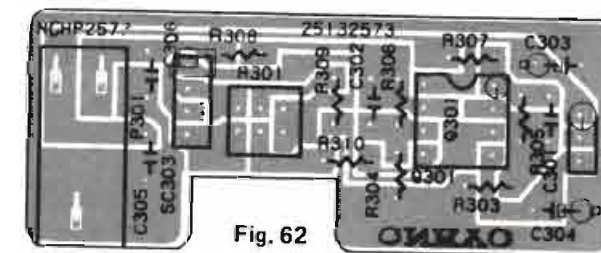

Fig. 62

TERMINAL PC BOARD

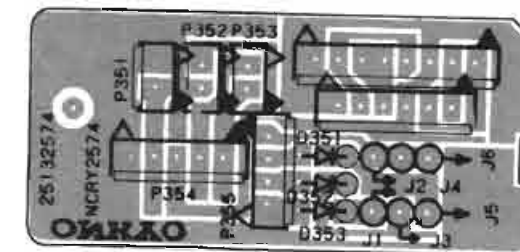

Fig. 63

POWER SUPPLY PC BOARD

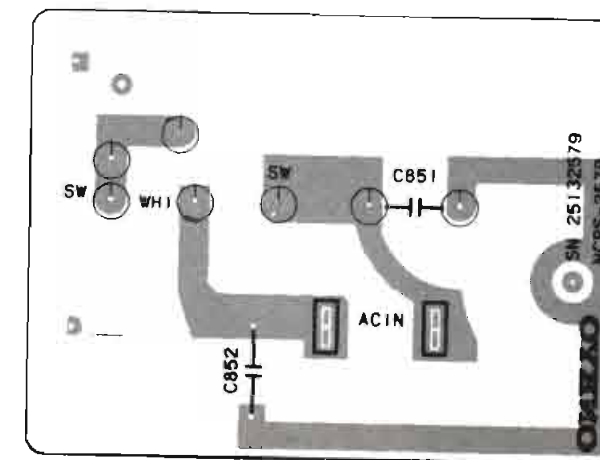

Fig. 64

TERMINAL PC BOARD (NARY-2574-1)

CIRCUIT NO.	PART NO.	DESCRIPTION
Diodes		
D351-D353	223155	1SS138
Plugs		
P351-P353	25055132	NPLG-2P-116
P354	25055135	NPLG-5P-119
P355	25055134	NPLG-4P-118

POWER SUPPLY PC BOARD (NAPS-2579-2/2A)

CIRCUIT NO.	PART NO.	DESCRIPTION
C851, C852	3500076	DE7090B471KAC400V/125V, Capacitor IS

PRINTED CIRCUIT BOARD VIEW FROM BOTTOM SIDE

Function switch pc board

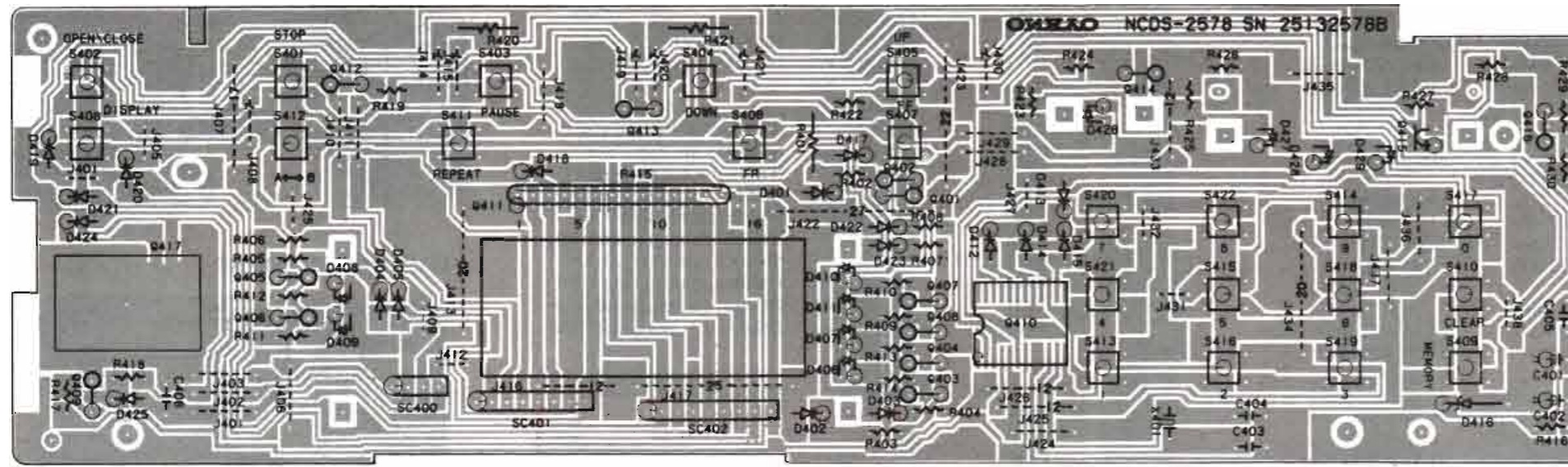

Fig. 65

Open switch pc board



Fig. 66

Close switch pc board

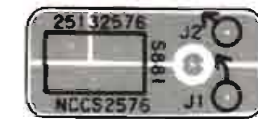

Fig. 67

Slide motor switch pc board



Fig. 68

FUNCTION SWITCH PC BOARD (NADS-2578-2)

CIRCUIT NO.	PART NO.	DESCRIPTION	CIRCUIT NO.	PART NO.	DESCRIPTION
Transistors			Ceramic oscillator		
Q401-Q409	2212834	2SC1652(R)	X401	3010101	CSB455E
Q412, Q413	2212834	2SC1652(R)	Capacitors		
Q414	2211455	2SA1015(GR)	C401, C402	353721019	100μF, 6.3V, Elect.
Q415	226024 or 226025	ST-23FB or ST-23FC, Photo	Resistor		
Q416	2212834	2SC1652(R)	R415	49421104412	100kohm x 12, 1/10W Network
IC			Switches		
Q410	222952	μPD6102G	S401-S422	25035389	NPS-111-S353, Push
Fluorescent display tube			Holders		
Q411	212030	4BT03ZK	27190433		LED A
Photoreceptor			27190431		Play
Q417	224162	HC-ON11, Remote control	Shielded plate		
Diodes			27150217		
D401-D405	223155	1SS138	Cushions		
D412-D415	223155	1SS138	28140663		
D416	2242602	RD3.0EB2	28140681		
D417-D423	223155	1SS138	NOTE: THE COMPONENTS IDENTIFIED BY MARK Δ ARE CRITICAL FOR RISK OF FIRE AND ELECTRIC SHOCK. REPLACE ONLY WITH PARTS NUMBER SPECIFIED.		
D425	223155	1SS138			
D427	2252202 or 2252203	EL-23FB or EL-23FC, Photo			
L.E.Ds					
D406, D407	225177	GL3PR28			
D408, D409	225179	GL3NG28			
D410, D411	225177	GL3PR28			
D426, D428					
D429					

Open/Close/Slide motor/Power switch pc boards (NAOS-2575-1/NACS-2576-1/NASS-2577-1/NASW-2591-2)

CIRCUIT NO.	PART NO.	DESCRIPTION
S871	25065260	NMS-1211, Microswitch
S881	25065260	NMS-1211, Microswitch
S891	25065261	NMS-1212, Microswitch
C861	3500065 A	Δ DE7150FZ103PAC400/125V Capacitor IS
S861	25035382	Δ NPS-111-346P, Pwer switch
	27300601	Δ Cover for C861

Power switch pc board

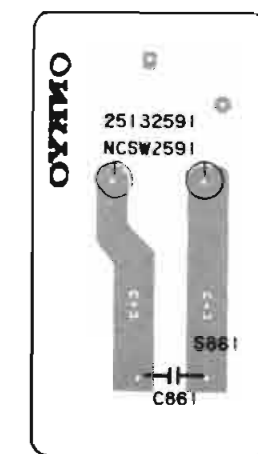
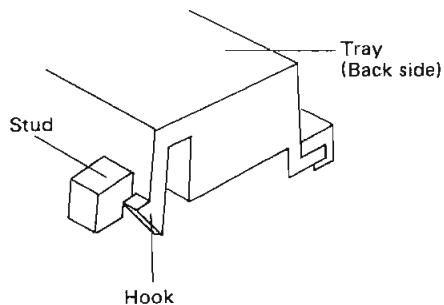

Fig. 69

DISASSEMBLING PROCEDUES

1. Tray ass'y

1. Remove the top cover.
2. Open the tray with pressing the open/close button.
3. Release hook of tray from the stud and pull tray out.



2. Disc motor

1. Remove the tray ass'y.
2. Remove the arm (Spring and screw).
3. Remove the four screws holding mechanism chassis and chassis.
4. Lift up the mechanism chassis and turn the turntable so that the hexagon screw becomes in the front.
5. Remove the hexagon screw with the hexagon wrench (1.25mm).
6. Remove the two screws on the disc motor.

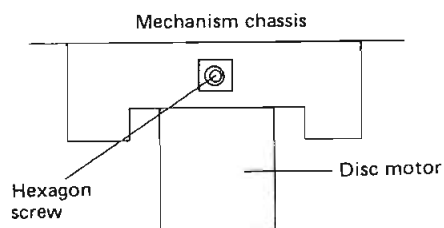

ONKYO CORPORATION

International Division: No. 24 Mori Bldg., 23-5, 3-chome, Nishi-Sinbashi, Minato-ku, Tokyo, Japan
Telex: 2423551 ONKYO J. Phone: 03-432-6981

ONKYO U.S.A. CORPORATION

200 Williams Drive, Ramsey, N.J. 07446 Tel. 201-825-7950

A605 Printed in Japan