

ONKYO® SERVICE MANUAL

COMPACT DISC PLAYER MODEL DX-6800

Black model

BUDN, BUD	120V AC, 60 Hz
BUG	220V AC, 50Hz
BUW	120/220V AC, 50/60Hz
BUQA, BUQB	240V AC, 50 Hz

SAFETY-RELATED COMPONENT WARNING!!

COMPONENTS IDENTIFIED BY MARK \triangle ON THE SCHEMATIC DIAGRAM AND IN THE PARTS LIST ARE CRITICAL FOR RISK OF FIRE AND ELECTRIC SHOCK. REPLACE THESE COMPONENTS WITH ONKYO PARTS WHOSE PARTS NUMBERS APPEAR AS SHOWN IN THIS MANUAL.

MAKE LEAKAGE-CURRENT OR RESISTANCE MEASUREMENTS TO DETERMINE THAT EXPOSED PARTS ARE ACCEPTABLY INSULATED FROM THE SUPPLY CIRCUIT BEFORE RETURNING THE APPLIANCE TO THE CUSTOMER.

SPECIFICATIONS

Signal readout system:	Optical non-contact
Reading rotation:	About 500~200r.p.m. (constant linear velocity)
Linear velocity:	1.2~1.4m/s
Error correction system:	Cross interleave readsolomon code
D/A converter:	1bit PWM×2 Accu Pulse Quartz System
Sampling frequency:	352.8kHz (8 times oversampling)
Number of channels:	2 (Stereo)
Frequency response:	2Hz~20kHz
Total harmonic distortion:	0.0025% (at 1kHz)
Dynamic Range:	100dB
Signal to noise ratio:	110dB
Channel separation:	103dB (at kHz)
Wow and Flutter:	Below threshold of measurability
Power consumption:	25 watts
Output level:	2 volts r.m.s.
Dimensions (W×H×D) :	435×132×358mm 17-1/8"×5-3/8"×14-1/8"
Weight:	8.8kg, 19.4lbs

Specifications are subject to change without notice.



TABLE OF CONTENTS

Specifications.....	1
Service procedures.....	2
Laser warning label	3
Chassis-exploded view	4
Parts list	5
Mechanism-exploded view.....	6
Parts list	7
Caution on replacement of pickup	8
Protection of eyes from laser beam during servicing	8
IC block diagrams and descriptions.....	9
Adjustment procedures	20
Pc board views.....	23
DAC and audio circuit pc board	23
Digital circuit pc board.....	23
Other pc boards.....	27
Pc board-parts list	28
Block diagram	29
Packing view	31

SERVICE PROCEDURES

1. How to Release the Transport Lock

To protect the optical assembly including the laser pickup from vibration related damage during shipping, this unit is equipped with a transport lock lever located on the base.

1. Loosen the screw with Phillips screwdriver.
2. Move the lock lever in the direction opposite that shown by the arrow. Move the lever up to the position where it can move no farther, and then remove the lever.

■ Tighten the screw to secure the lock lever.

- For shipping, restore the lock lever to its position in the direction of the arrow, then tighten down the screw to secure the lock lever in that position.

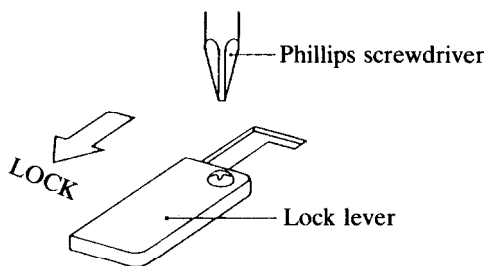

2. Use of batteries

- The remote control transmitter is powered by two batteries. Before using this unit for the first time, insert the two batteries (included).
- Average battery life is about one year. This period may be shorter depending on the frequency of use and environment (temperature and humidity) in which the remote control transmitter is used.

- If the remote control transmitter does not operate even though front panel controls function normally, the batteries should be replaced. Use only listed in the following chart.

Type	Voltage	Size
Manga- nese	1.5V	AA R6 UM-3

3. Safety check out

After correcting the original service problem, perform the following safety check before releasing the set to the customer:

Connect the insulating-resistance tester between the plug of power supply cable and chassis.

Specifications: more than 10Mohm at 500V.

4. Voltage selector (rear panel)

Worldwide models are equipped with a voltage selector to conform with local power supplies. Be sure to set this selector to match the voltage of the power supply in your area before turning the power switch on. Voltage is changed by turning the voltage selector with a screwdriver or similar instrument to the 120V or 220V position. Confirm that the selector has been set to the correct position before turning the power switch on. If there is no voltage selector switch on the unit you have purchased, it can only be used in areas where the power supply voltage is the same as that of the unit.

LASER WARNING LABEL

The label shown below are affixed.

1. Certification label (120V model)

This label is located on the back panel.

PRODUCT IS CERTIFIED BY THE MANUFACTURER TO COMPLY WITH DHHS RULES 21 CFR SUBCHAPTER J APPLICABLE AT THE DATE OF MANUFACTURE

MANUFACTURED

2. Class 1 label (Except 120V model)

This label is located on the back panel.

"CLASS 1 LASER PRODUCT"

3. Warning labels

This label is located on the chassis of mechanism.

DANGER —INVISIBLE LASER RADIATION WHEN OPEN AND INTERLOCK FAILED OR DEFEATED. AVOID DIRECT EXPOSURE TO BEAM

CAUTION —HAZARDOUS LASER AND ELECTROMAGNETIC RADIATION WHEN OPEN AND INTERLOCK DEFEATED

ATTENTION —RAYONNEMENT LASER ET ELECTROMAGNETIQUE DANGEREUX SI OUVERT AVEC L'ECLenchEMENT DE SECURITE ANNULE.



Except
120V
model

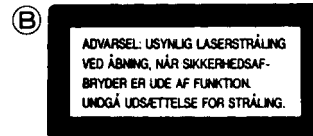

Except
120V
model

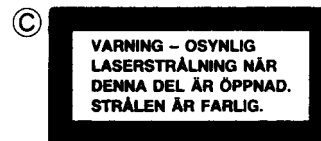

only
220V
model

ADVARSEL

"CLASS 1 LASER PRODUCT"

Denne mærkning er anbragt på apparatets højre side og indikerer, at apparatet arbejder med laserstråler af klasse 1, hvilket betyder, at der anvendes laserstråler af svageste klasse, og at man ikke på apparatets yderside kan blive udsat for utilladelig kraftig stråling.

VARNING - OSYNLIG LASERSTRÅLING NÅR DENNA DEL ÅR ÖPPNAD. STRÅLEN ÅR FARLIG.

APPARATET BØR KUN ÅBNES AF FAGFOLK MED SÆRLIGT KENDSKAB TIL APPARATER MED LASERSTRÅLER!

Indvendigt i apparatet er anbragt den her gengivne advarselsmærkning, som advarer imod at foretage sadanne indgreb i apparatet, at man kan komme til at udsætte sig for laserstråling.

ADVARSEL USYNLIG LASERSTRÅLING VED ÅBNING, NÅR SIKKERHEDSAFBRYDER ER UDE AF FUNKTION. UNDGÅ UDSÆTTELSE FOR STRÅLING

VAROITUS! Laite sisältää laserdiodin, joka lähettää (näkymätöntä) silmille vaarallista lasersäteilyä.

SCHEMATIC DIAGRAM

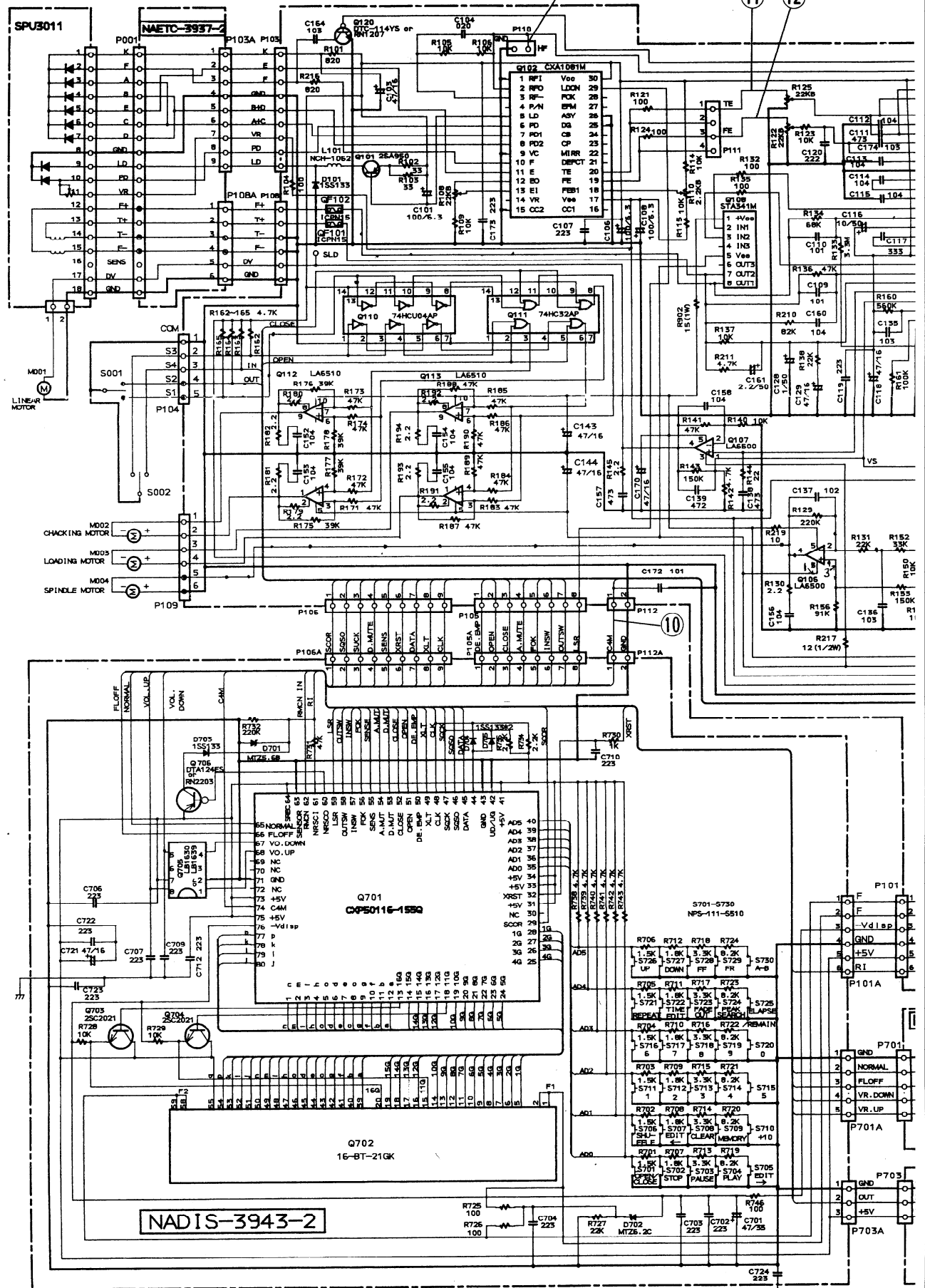

A

B

C

D

E

F

8

11

12

10

NADG-3941-2

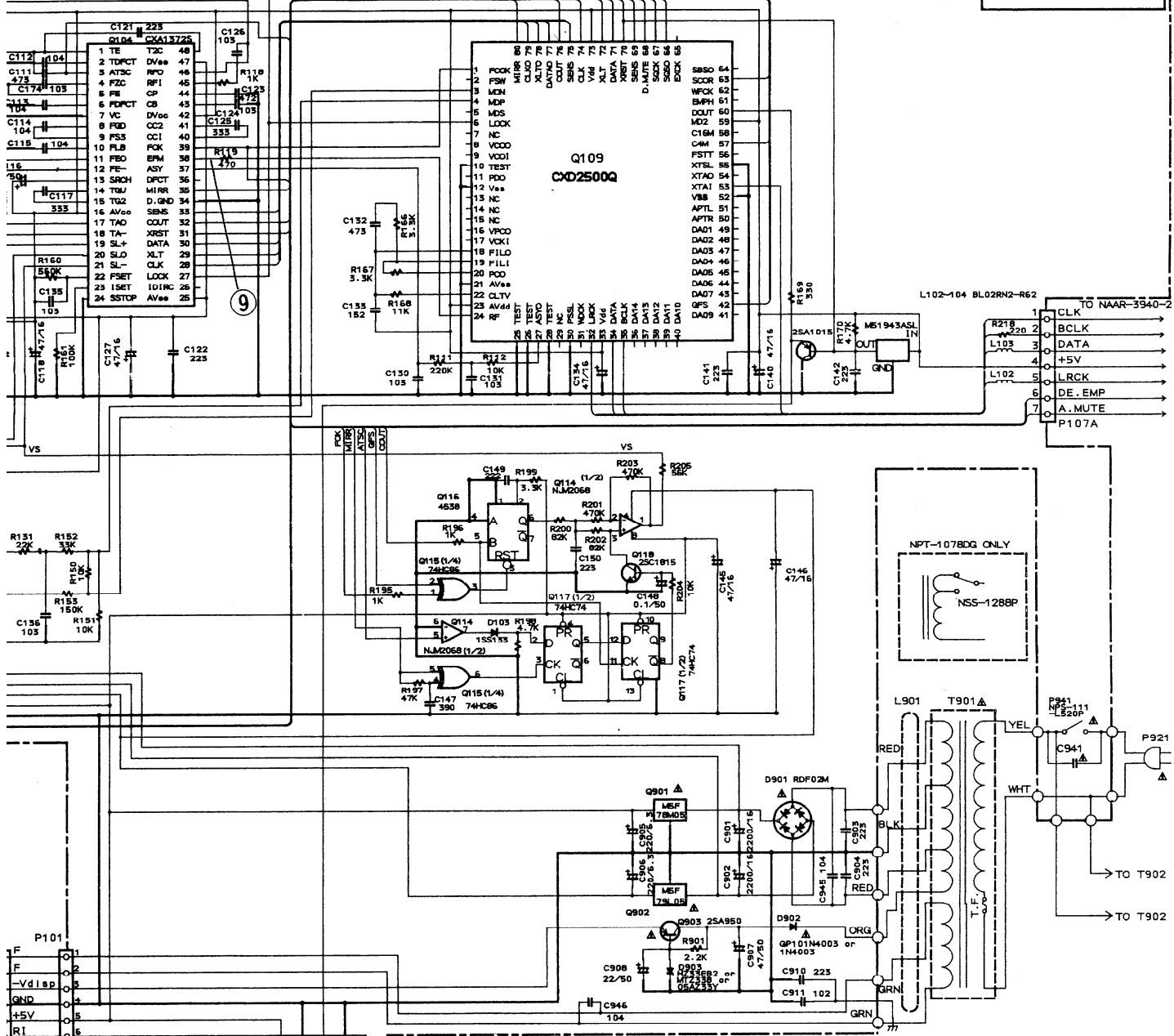

	RATING	T901	QF101-102	P921	C941	L901
UD	AC120V/60Hz	NPT-1078D	WITHOUT	AS-UC-4 #18	0.01/125V	TR-23-11-14
UG	AC220V/50Hz	NPT-1078G	WITH	AS-CEE	0.01/400V	TR-16-8-16
UW	AC120/220V 50/60Hz	NPT-1078DG	WITH	AS-CEE	0.01/400V	TR-16-8-16
UQ	AC240V/50Hz	NPT-1078Q	WITH	AS-SAA	0.01/400V	TR-16-8-16

- NOTE**
- THE COMPONENTS IDENTIFIED BY MARK Δ ARE CRITICAL FOR SAFETY. REPLACE ONLY WITH PART NUMBER SPECIFIED.
 - VOLTAGE (MEASURED WITH VOLTMETER) \square IS DC VOLTAGE. (NO INPUT SIGNAL)
 - ALL PNP TRANSISTORS ARE EQUIVALENT TO 2SA1015-GR UNLESS OTHERWISE NOTED.
 - ALL NPN TRANSISTORS ARE EQUIVALENT TO 2SC1815-GR UNLESS OTHERWISE NOTED.
 - ALL DIODES ARE EQUIVALENT TO 1SS133 UNLESS OTHERWISE NOTED.
 - ELECTROLYTIC CAPACITORS (E) ARE IN μ F/VV.
 - ALL CAPACITORS ARE IN pF/50WV UNLESS OTHERWISE NOTED.
 - EX) 33F=0.33, 33F=330, 330F=33, 0, 033F=333
 - ALL RESISTORS ARE IN OHMS 1/4 WATTS UNLESS OTHERWISE NOTED.
 - THE THICK LINES IN PC BOARD ARE THE PRINTING SIDE OF THE PARTS.
 - EX) \square PRINTING SIDE
 - CIRCUIT IS SUBJECT TO CHANGE FOR IMPROVEMENT.

SCHEMATIC DIAGRAM

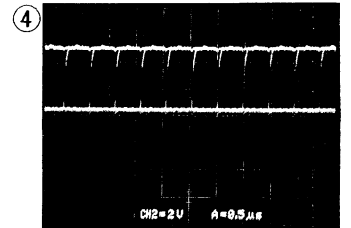
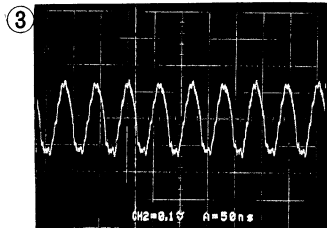
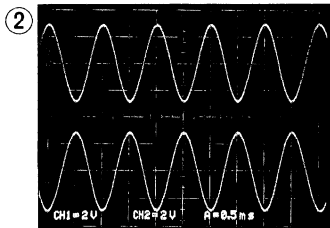
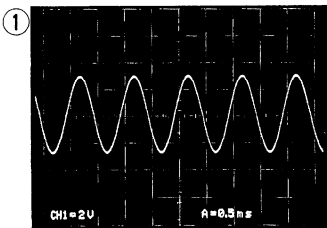
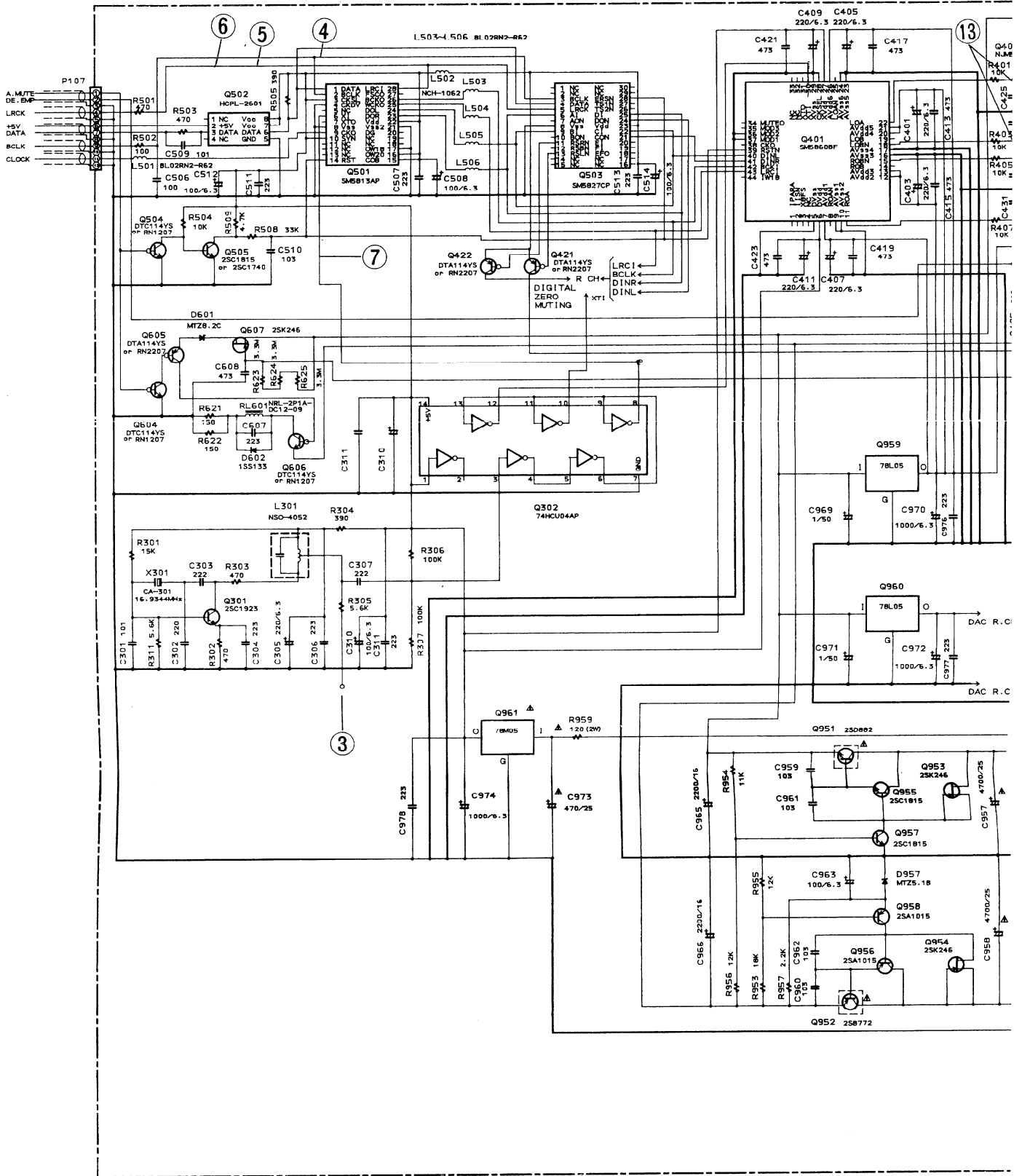

NAAR-3940-2

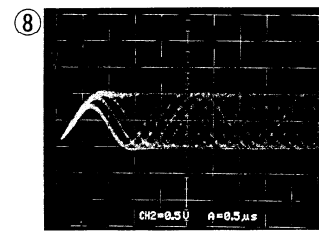
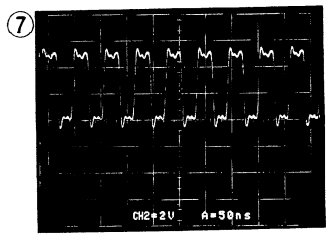
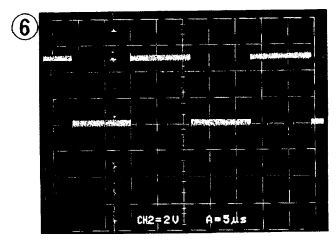
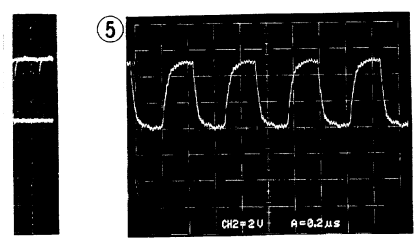
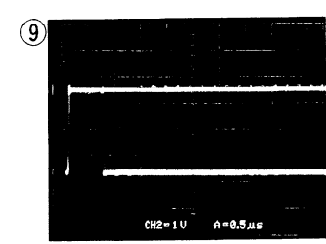
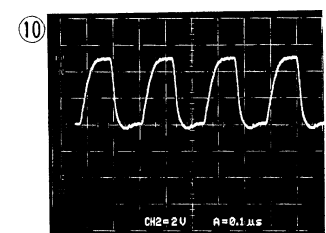
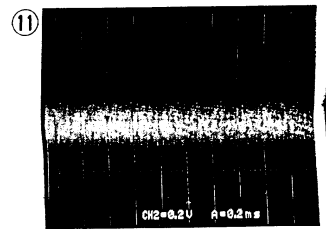
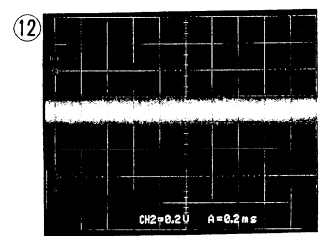
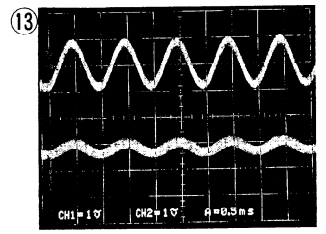
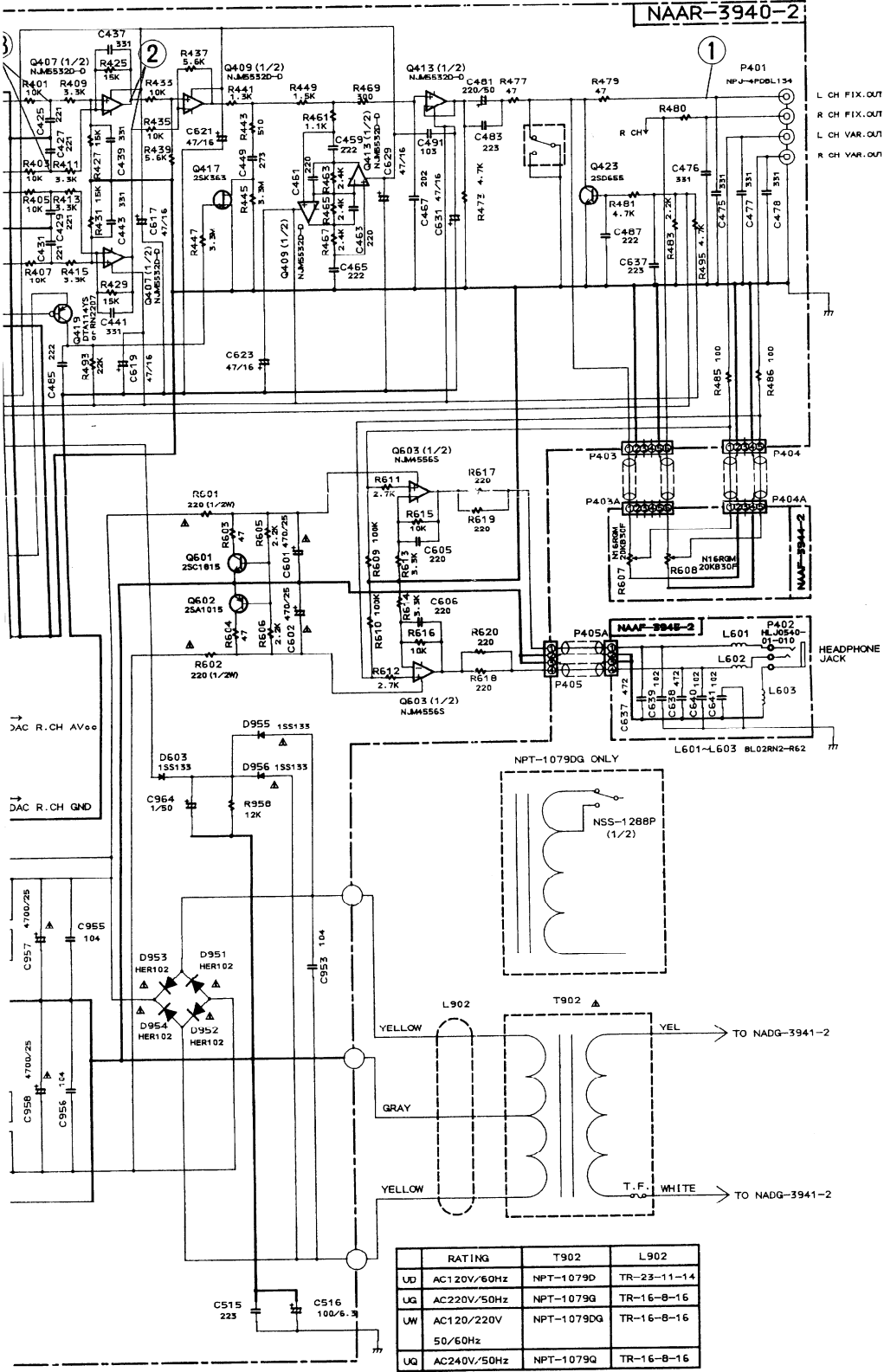

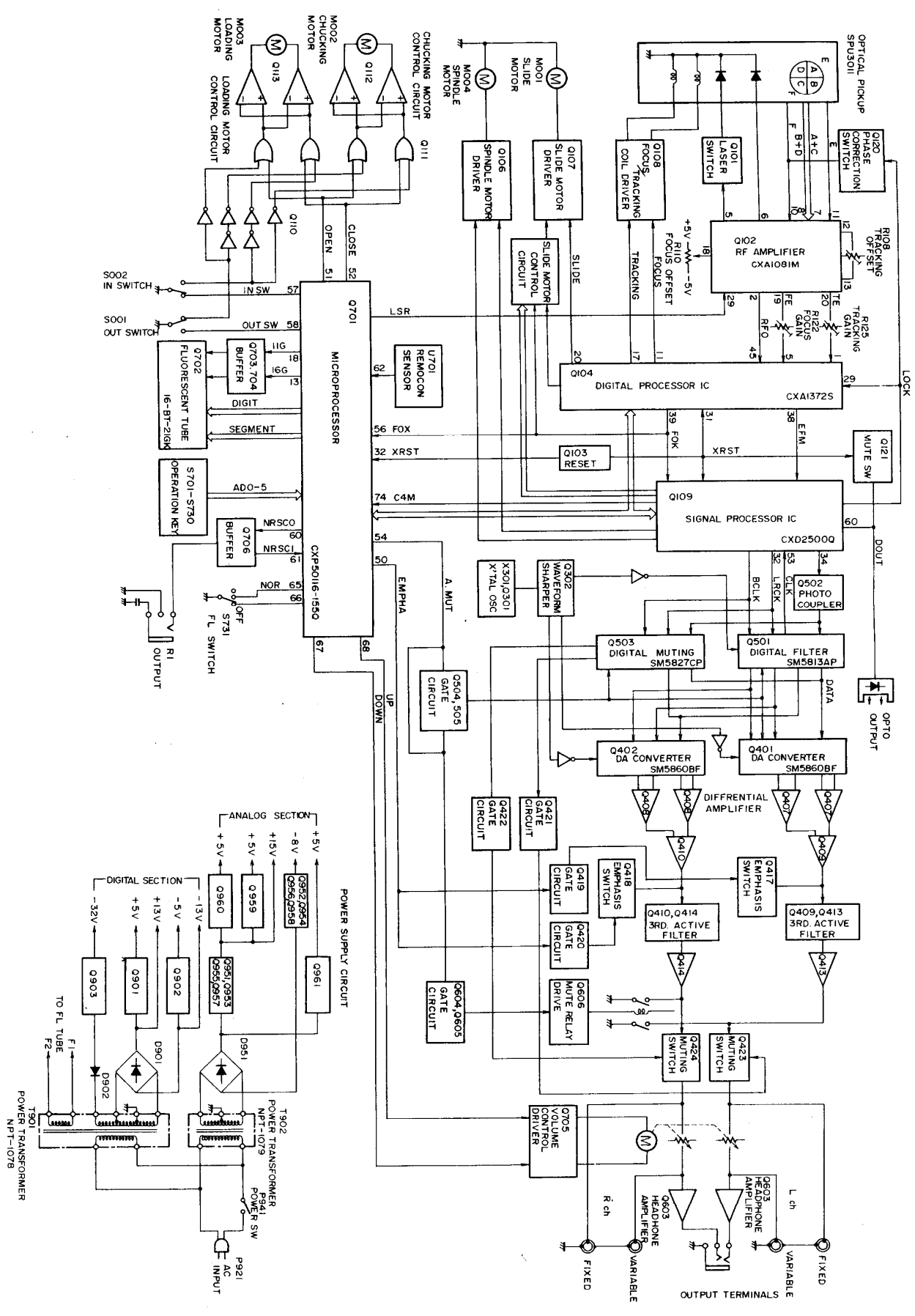

CHASSIS-EXPLODED VIEW

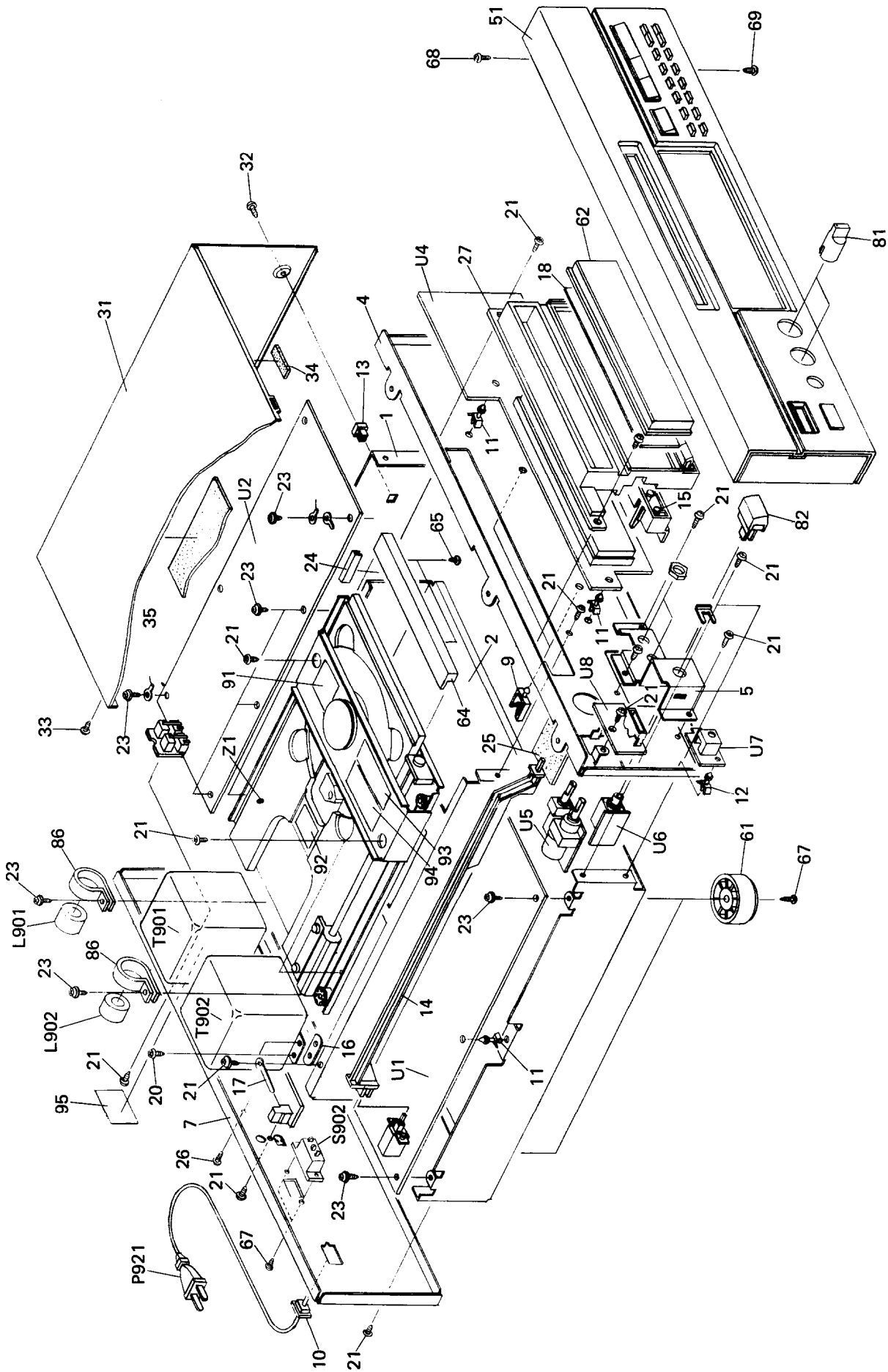

PARTS LIST

REF. NO.	PART NO.	DESCRIPTION	REF. NO.	PART NO.	DESCRIPTION
1	27100221A	Chassis	91	29360807	Label,danger
2	27130620A	Bracket,center	92	29361218	Label,laser (G)
4	27110583A	Front bracket	93	29360811A	Label (G)
5	27141410	Bracket,headphone	94	29361298	Label SEM (G/Q)
7	27121376A	Back panel (D)	95	29360687	Label,class 1 (G/W/Q)
	27121376-1A	Back panel (G)	L901,L902	230908	TR-23-11-14,Core (D)
	27121376-2A	Back panel (W)	P921	230907	TR-16-8-16,Core (G/W/Q)
	27121376-4A	Back panel (Q)		253112A	AS-UC4#18,Power supply cord (D)
9	27300833	WS-2NS,Clamp		2531480r	AS-CEE250V2.5A
10	27300750	Bushing(strainrelief)		253150	Power supply cord (G/W)
11	27190009	KGLS-4S,Holder	S902	253118	AS-SAA, Powersupplycord (Q)
12	27190480	KGLS-8S,Holder	T901	25065195	NSS-1288P, Voltage selector switch (W)
13	27190717	Holder S		2300581B	NPT-1078D,Power transformer (D)
14	27273132A	Joint,power		2300582B	NPT-1078G,Power transformer (G)
15	27190776A	Holder		2300583B	NPT-1078DG,Power transformer (W)
16	27270327A	Spacer		2300584B	NPT-1078Q,Power transformer (Q)
17	27255004	CS-1U,Clip	T902	2300585B	NPT-1079D,Power transformer (D)
18	28133247	Back plate		2300586B	NPT-1079G,Power transformer (G)
20	838440109	4TTB+10C(BC),Self-tapping screw		2300587B	NPT-1079DG,Power transformer (W)
21	801230	3TTS+8BQ(BC),Self-tapping screw	U1	2300588B	NPT-1079Q,Power transformer (Q)
22	834430108	3TTS+10B(BC),Self-tapping screw (D)	U2	1H138540-2	NAAR-3940-2,DAC and audio circuit pc board ass'y
	831130088	3TTW+8B,Self-tapping screw (G/Q/W)		1H138541-2	NADG-3941-2,Digital circuit pc board ass'y (D)
23	831130088	3TTW+8B,Self-tapping screw (G/Q/W)	U3	1H138541-2A	NADG-3941-2A,Digital circuit pc board ass'y (G/Q/W)
24	28170014	CE-012,Bushing	U4	1H138542-2	NADG-3942-2,Opto.output pc board ass'y
25	28141074	0.3×65×65,Cushion		1H138543-2	NADIS-3943-2,Display circuit pc board ass'y (D)
26	834230108	3TTS+10B(Ni),Nickel screw	U5	1H138543-2A	NADIS-3943-2A,Display circuit pc board ass'y (G/Q/W)
27	27190779A	Holder	U6	1H138544-2	NAAF-3944-2,Output level volume pc board ass'y
31	28184401	Top cover	U7	1H138545-2	NAAF-3945-2,Audio circuit pc board ass'y
32	838440108	4TTB+10B(BC),Self-tapping screw	U8	1H138546-2	NAETC-3946-2,Remote control sensor pc board ass'y
33	834430088	3TTS+8B(BC),Self-tapping screw	Z1	1H138547-2	NAETC-3947-2,Power indicator pc board ass'y
34	28140408	3×10×36,Cushion		1H134122	NCD-38M,CD mechanism ass'y
35	28141009	15×195×125,Cushion		260208	Binder
51	1H138121	Front panel ass'y			
61	27175153-1	Leg			
62	28191567	Clear plate			
64	28148246B	Door			
65	838430068	3TTB+6B(BC),Self-tapping screw			
67	834430088	3TTS+8B(BC),Self-tapping screw			
68	838430089	3TTB+8C(BC),Self-tapping screw			
69	834430068	3TTS+6B(BC),Self-tapping screw			
81	28324062A	Knob,level			
82	28323987	Knob,power			
86	260223	NK-16N,Clamp (D)			
	260221	NK-10N,Clamp (G/W/Q)			

NOTE (D) : Only 120V model
(G) : Only 220V model
(W) : Only Worldwide model
(Q) : Only 240V model

NOTE: THE COMPONENTS IDENTIFIED BY MARK Δ ARE CRITICAL FOR RISK OF FIRE AND ELECTRIC SHOCK. REPLACE ONLY WITH PART NUMBER SPECIFIED.

MECHANISM-EXPLODED VIEW

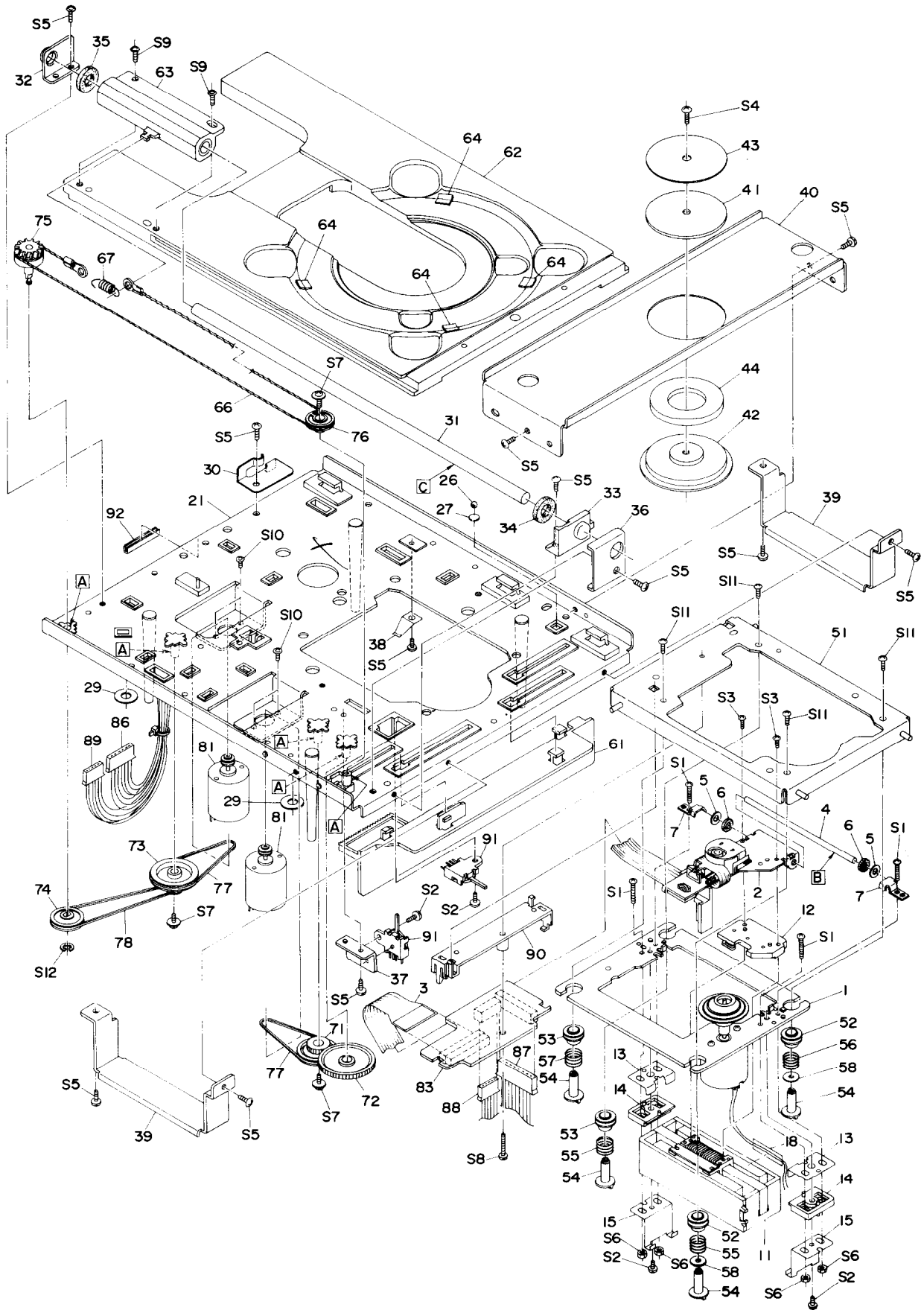

PARTS LIST

REF. NO.	PART NO.	DESCRIPTION	REF. NO.	PART NO.	DESCRIPTION
1	<u>27100219A</u>	Chassis ass'y pickup	90	27190775	Holder
2	<u>24110007A</u>	Optical pickup	91	25065422	NMS-1220, Microswitch
3	25134076	NCETC-4076, Flake pc board	92	28170024	Bushing
4	24506955	Shaft	S1	82112010	2P+10F, Pan head screw
5	27270322	Spacer	S2	838426088	2.6TTB+8B(BC), Self-tapping screw
6	27270323	Spacer	S3	838120080	2TTB+8P, Self-tapping screw
7	24506952	Bracket, shaft	S4	833426050	2.6TTP+5P(BC), Self-tapping screw
11	24502261	SLA2001, Motor, slide	S5	834430068	3TTS+6B(BC), Self-tapping screw
12	24506950	Block, terminal	S6	863120	N-2F, Nut
13	24506953	Bracket LM	S7	831126060	2.6TTW+6P, Self-tapping screw
14	24506951	Base LM	S8	833326148	2.6TTP+14B, Self-tapping screw
15	24506954	Holder LM	S9	838430088	3TTB+8B(BC), Self-tapping screw
18	28141068	Cushion	S10	82143004	3P+4FN(BC), Pan head screw
21	27301335B	Chassis L	S11	838120080	2TTB+8P, Self-tapping screw
26	27301419	Steelball	S12	8930251S	ES-2.5S, Ring E
27	27270331	Spacer			
29	27270212 X4	Spacer			
30	27180467	Plate spring			
31	27260297A	Shaft, guide			
32	27141408	Bracket, shaft			
33	27301342	Shaft base			
34	27270324	Spacer			
35	27270325A	Spacer			
36	27141438	Bracket, base			
37	27141409	Bracket, switch			
38	27180460	Spring			
39	27141440	Bracket H			
40	27301343	Arm			
41	28141061A	Cushion CH			
42	27301352	Cap CH			
43	27301344	Yoke CH			
44	28181019A	Magnet CH			
51	27301345	Chassis, sub			
52	27301418	Cushion rubber			
53	27301346	Cushion rubber			
54	27301347	Spacer, floating			
55	27180461	Spring, silver			
56	27180462	Spring, green			
57	27180463	Spring, yellow			
58	27270330	Spacer			
61	27301349A	Cam plate			
62	27301331C	Disc tray			
63	27301333A	Guide bearing			
64	28141081	Cushion, tray			
66	27301391	Rope			
67	27180464	Spring, wire			
71	27301336	Pulley gear			
72	27301337	Flat wheel			
73	27301338	Middle pulley			
74	27301339	Pulley			
75	27301389	Drive pulley			
76	27301341	Flat pulley			
77	27301350	Rubber belt S			
78	27301351	Rubber belt L			
81	1H048902	Motor ass'y			
83	1H134537-1	NAETC-3937-1, Terminal pc board ass'y			
86	2009990098A	NSAS-6P0137, Socket			
87	2009990099B	NSAS-18P0138, Socket			
88	2002391245	NSAS-12P0213, Socket			
89	2009990126A	NSAS-5P0197, Socket			

TERMINAL PC BOARD-PARTS LIST

CIRCUIT NO.	PART NO.	DESCRIPTION
P001	25050428	NSCT-18P, Socket
P103A	25055139	NPLG-9P123, Plug
P108A	25055150	NPLG-6P134, Plug

LUBRICATION

	PART NO.
<input type="checkbox"/> G902S	260447
<input type="checkbox"/> # 331	260451
<input type="checkbox"/> G947P	

CAUTION ON REPLACEMENT OF PICKUP

The laser diode in the optical pickup block is so sensitive to static electricity, surge current and etc. that the components are liable to be broken down or its reliability remarkably deteriorated.

During repair, carefully take the following precautions. (The following precautions are included in the service parts).

PRECAUTIONS

1. Ground for the work-desk.

Place a conductive sheet such as a sheet of copper (with impedance lower than $10^6 \Omega$) on the work-desk and place the set on the conductive sheet so that the chassis.

2. Grounding for the test equipment and tools.

Test equipments and toolings should be grounded in order that their ground level is the same the ground of the power source.

3. Grounding for the human body.

Be sure to put on a wrist-strap for grounding whose other end is grounded.

Be particularly careful when the workers wear synthetic fiber clothes, or air is dry.

4. Select a soldering iron that permits no leakage and have the tip of the iron well-grounded.

5. Do not check the laser diode terminals with the probe of a circuit tester or oscilloscope.

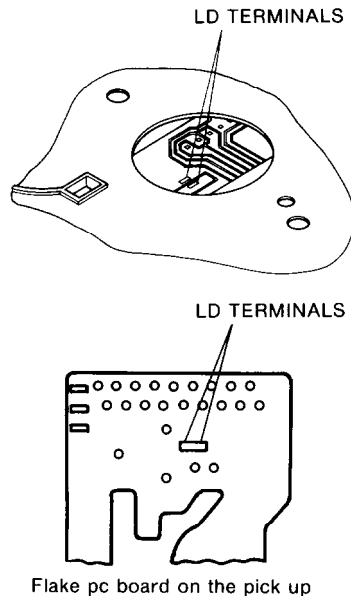

(Care should be taken with the optical pickup.)

The optical pickup is sensitive to static electricity, surge currents, and other high electrical noise, and because there is the possibility of damage to performance, in the handling of the pickup, the utmost care must be taken, particularly with regard to static electricity.

Mechanism ass'y removal

When remove the mechanism ass'y, first short the LD terminals on the pc board and remove the mechanism ass'y.

Optical pickup removal

1. When replacing the optical pickup, first short the LD terminals and remove the connector. Also, when attaching the new optical pickup, after attaching the connector, unsolder the LD terminals.
2. Do not touch the optical pickup object lens with the hands.

PROTECTION OF EYES FROM LASER BEAM DURING SERVICING

This set employs a laser. Therefore, be sure to follow carefully the instructions below when servicing.

WARNING!!

WHEN SERVICING, DO NOT APPROACH THE LASER EXIT WITH THE EYE TOO CLOSELY. IN CASE IT IS NECESSARY TO CONFIRM LASER BEAM EMISSION, BE SURE TO OBSERVE FROM A DISTANCE OF MORE THAN 30cm FROM THE SURFACE OF THE OBJECTIVE LENS ON THE OPTICAL PICK-UP BLOCK.

Laser Diode Properties

- Material: GaAs/GaAlAs
- Wavelength: 780nm
- Emission Duration: continuous
- Laser output: max. 0.5mW*

*This output is the value measured at a distance about 1.8mm from the objective lens surface on the Optical Pick-up Block.

3. Focus gain adjustment

Set the output of AF oscillator to 800Hz, 1~1.5Vp-p.

Play the track 2 of test disc.

Connect the oscilloscope and the AF oscillator as shown below.

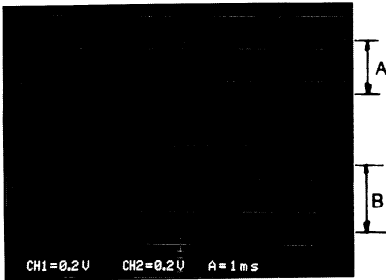
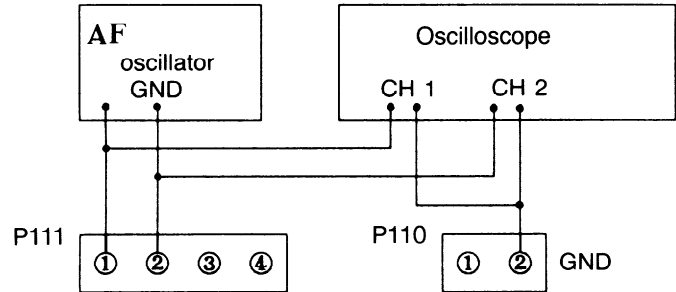

Photo 3



Adjust R122 until 800Hz components of channels 1 and 2 on oscilloscope become same level.

After adjustment, disconnect the AF oscillator and the oscilloscope.

4. Tracking gain adjustment

Set the output of AF oscillator to 1.2kHz, 1~1.5Vp-p.

Play the track 2 of test disc.

Connect the oscilloscope and the AF oscillator as shown below.

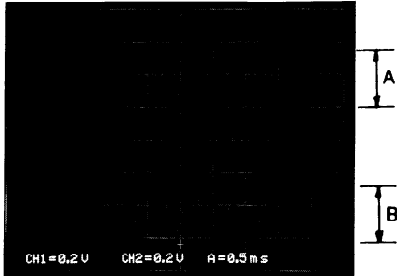
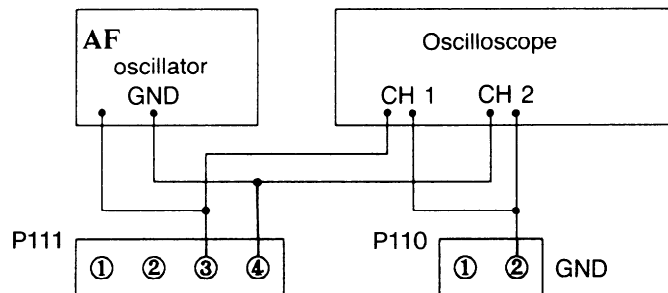

Photo 4



Adjust R125 until 1.2kHz components of channels 1 and 2 on oscilloscope become same level.

After adjustment, disconnect the AF oscillator and the oscilloscope.

After adjustment, confirm that the center of tracking error signal becomes GND level.

5. Oscillation level adjustment

Connect the oscilloscope across the terminal TP501 and ground.

(Use the high impedance probe (10:1).)

Set the range on the oscilloscope to AC.

Adjust L301 so that the level of oscillation becomes 250mVp-p.

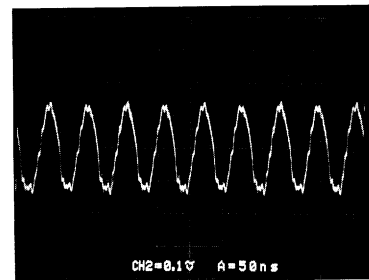

ADJUSTMENT PROCEDURES

Instruments required

Dual trace oscilloscope, Frequency counter, AF oscillator, Test disc (SONY YEDS-18), AC voltmeter, and Socket P4(Part no. 25050138)

1. Focus offset adjustment

Load the test disc YEDS-18 on the tray and play the track 2.

Connect the oscilloscope to terminal P110.

Adjust R108 until the waveform on the oscilloscope becomes maximum.

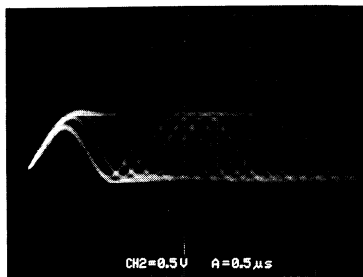
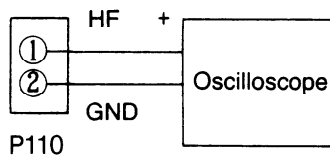

Photo 1



2. Tracking offset adjustment

Load the test disc YEDS-18 on the tray and play the track 2.

Turn R125 to minimum position. (Counter clockwise)

Connect the oscilloscope across pin 3 (TR) of P111 and P110. (Ground)

Adjust R110 until the center of tracking error signal on the oscilloscope becomes GND level.

Turn R125 to the mechanical center.

After adjustment, disconnect the oscilloscope.

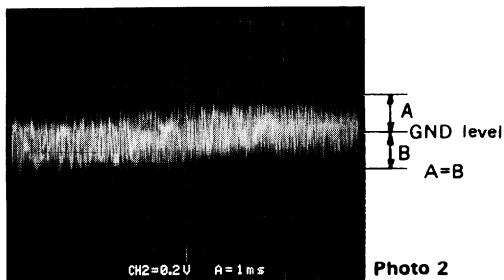
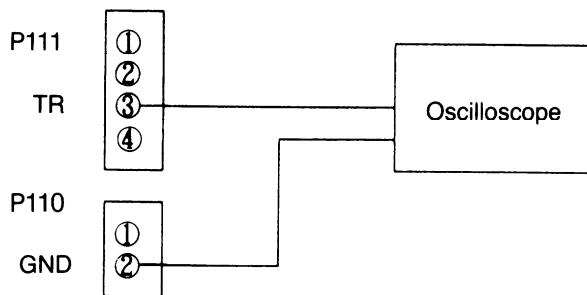
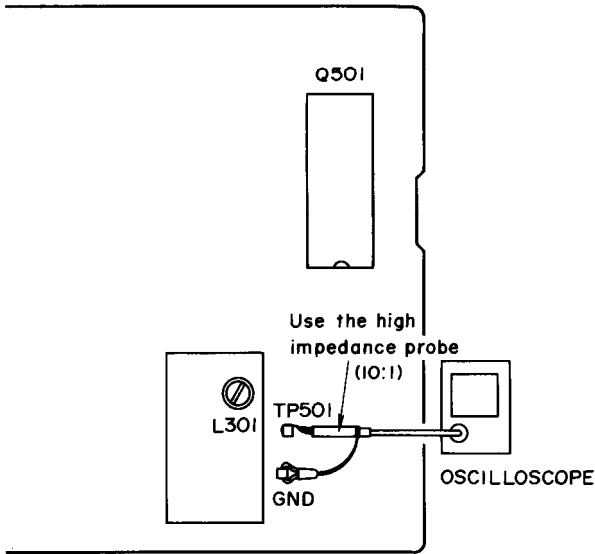
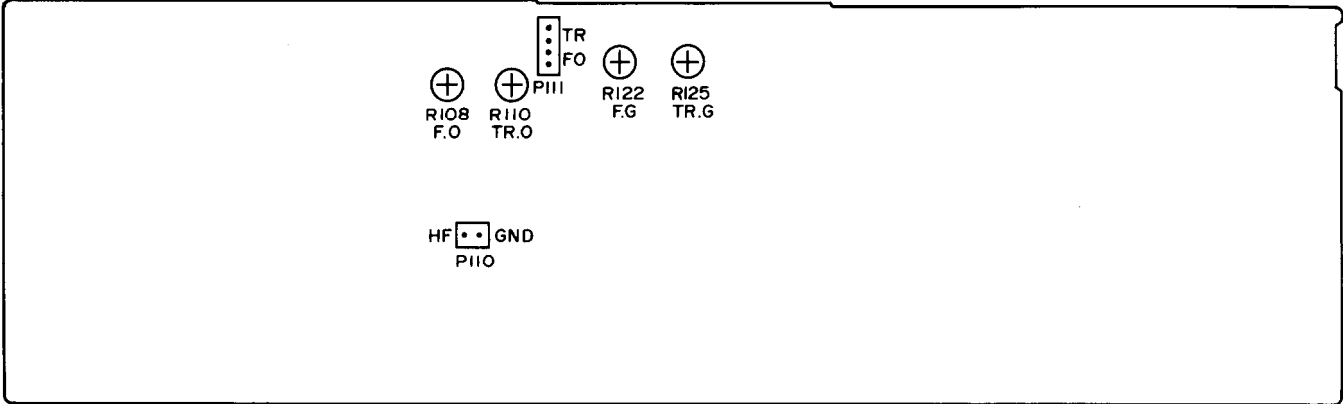

Photo 2





Adjustment point

PRINTED CIRCUIT BOARD – PARTS LIST

DAC AND AUDIO CIRCUIT PC BOARD (NAAR-3940-2)

CIRCUIT NO.	PART NO.	DESCRIPTION
		ICs
Q302	222755	74HCU04P
Q401, Q402	22240363	SM5860BF
Q407-Q410	222902	NJM5532D-D
Q413, Q414	222902	NJM5532D-D
Q501	22240288	SM5813AP
Q502	226027	HCPL-2601
Q503	22240364	SM5827CP
Q603	222887	NJM4556S
Q959, Q960	222780053	78L05
Q961	222780052	78M05
		Transistors
Q301	2211723	2SC1923-O
Q417, Q418	2212524 or 2212525	2SK363-GR or 2SK363-BL
Q419-Q422	2213090 or	DTA114Y Sor
Q605	2213590	RN2207
Q423, Q424	2211705 or 2211706	2SD655-E or 2SD655-F
Q504, Q604	221281 or	DTC114YS or
Q606	2213570	RN1207
Q505	2211254, 2211255 or 2211183	2SC1815-Y, 2SC1815-GR or 2SC1740-R
Q601	2211254 or 2211255	2SC1815-Y or 2SC1815-GR
Q602, Q956	2211454 or	2SA1015-Y or
Q958	2211455	2SA1015-GR
Q607	2211945	2SK246-GR
Q951	2201284 or 2201285	2SD882-R or 2SD882-Q
Q952	2201274 or 2201275	2SB772-R or 2SB772-Q
Q953, Q954	2211945	2SK246-GR
Q955, Q957	2211254 or 2211255	2SC1815-Y or 2SC1815-GR
		Diodes
D601	224150823 or 224650823	05AZ8.2Z or HZ8.2EB3
D602, D603	223163	1SS133
D951-D954	22380029	HER102
D955, D956	223163	1SS133
D957	224650512 or 224150512	HZ5.1EB2 or 05AZ5.1Y
		Crystal
X301	3010156	CA301
		Coils
L301	232153	NSO-4052
L502	231023	NCH-1062
		Cores
L501	230906	BL02RN2-R62
L503-L506	230906	BL02RN2-R62
		Relay
RL601	25065174	NRL-2P1A-DC12-09
		Capacitors
C305	354722219	220 μ F, 6.3V, Elect.
C310	354721019	100 μ F, 6.3V, Elect.
C401-C412	354722219	220 μ F, 6.3V, Elect.
C413-C424	374724734	0.047 μ F 5%, 50V, TF
C425-C432	373302214	220pF 5%, 125V, PP
C437-C444	373303314	330pF 5%, 125V, PP

C449, C450	371122734	0.027 μ F 5%, 50V, Mylar
C459, C460	373632224	2200pF 5%, 100V, KP
C465, C466	373632224	2200pF 5%, 100V, KP
C467, C468	372122024	2000pF 5%, 50V, Styrole
C475-C478	373633314	330pF 5%, 100V, KP
C481, C482	354782219	220 μ F, 50V, Elect.
C483, C484	374722234	0.022 μ F 5%, 50V, TF
C485, C486	373632224	2200pF 5%, 100V, KP
C487, C488	374722224	2200PF 5%, 50V, TF
C491, C492	373691034	0.01 μ F 5%, 63V, KP
C508, C512	354721019	100 μ F, 6.3V, Elect.
C516	354721019	100 μ F, 6.3V, Elect.
C601, C602	393154717	470 μ F, 25V, Elect. (FM)
C607	373732234	0.022 μ F 5%, 100V, MKT
C608	371124734	0.047 μ F 5%, 50V, Mylar
C617-C624	354744709	47 μ F, 16V, Elect.
C629-C632	354744709	47 μ F, 16V, Elect.
C953	374721044	0.1 μ F 5%, 63V, TF
C955, C956	373791044	0.1 μ F 5%, 63V, MKT
C957, C958	393154727	4700 μ F, 25V, Elect. (FM)
C963	354721019	100 μ F, 6.3V, Elect.
C964	354780109	1 μ F, 50V, Elect.
C965, C966	393142227	2200 μ F, 16V, Elect. (FM)
C969, C971	354780109	1 μ F, 50V, Elect.
C970, C972	393121027	1000 μ F, 6.3V, Elect. (FM)
C973	393154717	470 μ F, 25V, Elect. (FM)
C974	393121027	1000 μ F, 6.3V, Elect. (FM)
C976-C978	374722234	0.022 μ F 5%, 50V, TF
		Resistors
R601, R602	442522214	220ohm, 1/2W, Metal oxide film
R959	441721214	120ohm, 2W, Metal oxide film
		Terminal
P401	25045267	NPJ-4PDBL134, Output
		Plugs
P107	25055156	NPLG-12P140
P403	25055150	NPLG-6P134
P404	25055149	NPLG-5P133
P405	25055148	NPLG-4P132
		Sockets
2009990132		NSAS-2P0208
2009990131		NSAS-2P0207
		Radiators
27160220		RAD51(B)
		Buss
27160215-1		
		Holder
27190751		
		Cover
27225107		shield
		Clamps
27301186		

DIGITAL CIRCUIT PC BOARD (NADG-3941-1/1A)

CIRCUIT NO.	PART NO.	DESCRIPTION
		ICs
Q102	22240029	CXA1081M
Q103	22240018	M51943ASL
Q104	22240366	CXA1372S
Q106, Q107	22240033	LA6500
Q108	22240168	STA341M-L
Q109	22240365	CXD2500Q
Q110	222755	74HCU04P
Q111	222740325TOS	74HC32AP
Q112, Q113	22240034	LA6510

Q114	222956	NJM2068DD
Q115	222740865	74HC86P
Q116	222850381	HD14538BP
Q117	222740745	74HC74P
Q901	222780055MIT	△M5F78M05
Q902	222790055MIT	△M5F79M05
Transistors		
Q101,Q903	2211503 or 2211504	△2SA950-O or △2SA950-Y(△:Only Q903)
Q118	2211254 or 2211255	2SC1815-Y or 2SC1815-GR
Q120	221281 or 2213570	DTC-114YS or RN1207
Q121	2211454 or 2211455	2SA1015-Y or 2SA1015-GR
Diodes		
D101,D103	223163	1SS133
D901	22380013	△RDF02M
D902	223880 or 223896	△GP1N4003 or △1N4003
D903	224653302, 224453302 or 224153302	HZ333EB2, MTZ333B or 05AZ33Y
Coil		
L101	231023	NCH-1062
Cores		
L102,L103	230906	BL02RN2-R62
Capacitors		
C101	354721019	100 μF,6.3V,Elect.
C103	354744709	47 μF,16V,Elect.
C106,C108	354721019	100 μF,6.3V,Elect.
C111	371124734	0.047 μF 5%,50V,Mylar
C112-C115	371121044	0.1 μF 5%,50V,Mylar
C116	354781009	10 μF,50V,Elect.
C117,C125	371123334	0.033 μF 5%,50V,Mylar
C118	354744709	47 μF,16V,Elect.
C120	371122224	2200pF 5%,50V,Mylar
C121	371122234	0.022 μF 5%,50V,Mylar
C123	371124724	4700pF 5%,50V,Mylar
C124,C126	371121034	0.01 μF 5%,50V,Mylar
C127,C129	354744709	47 μF,16V,Elect.
C128	354780109	1 μF,50V,Elect.
C130,C131	371121034	0.01 μF 5%,50V,Mylar
C132	371124734	0.047 μF 5%,50V,Mylar
C133	371121524	1500pF 5%,50V,Mylar
C134	354744709	47 μF,16V,Elect.
C135,C136	371121034	0.01 μF 5%,50V,Mylar
C137,C157	371121024	1000pF 5%,50V,Mylar
C138	371124734	0.047 μF 5%,50V,Mylar
C139	371124724	4700pF 5%,50V,Mylar
C140	354744709	47 μF,16V,Elect.
C143-C146	354744709	47 μF,16V,Elect.
C148	354781099	0.1 μF,50V,Elect.
C149	371122224	2200pF 5%,50V,Mylar
C150	371122234	0.022 μF 5%,50V,Mylar
C152-C156	371121044	0.1 μF 5%,50V,Mylar
C158,174	371121034	0.01 μF 5%,50V,Mylar
C160	371121044	0.1 μF 5%,50V,Mylar
C161	354780229	2.2 μF,50V,Elect.
C164	371121034	0.01 μF 5%,50V,Mylar
C170	354744709	47 μF,16V,Elect.
C901,C902	354742229	2200 μF,16V,Elect.
C905,C906	354722219	220 μF,6.3V,Elect.
C907	354784709	47 μF,50V,Elect.
C908	354782209	22 μF,50V,Elect.

C941	3500065A	△DE7150F103PAC400V/125V,IS
C945,C946	374721044	0.1 μF 5%,50V,TF
Resistors		
R108	5210066	N06HR22KBD,Semi-fixed
R110	5210060	N06HR2.2KBD,Semi-fixed
R122,R125	5210066	N06HR22KBD,Semi-fixed
R217	442521204	12ohm,1/2W,Metal oxide film
R902	441621504	15ohm,1W,Metal oxide film
Plugs		
P101	25055150	NPLG-6P134
P103	25055139	NPLG-9P123
P104	25055149	NPLG-5P133
P105	25055152	NPLG-8P136
P106	25055153	NPLG-9P137
P108,P109	25055150	NPLG-6P134
P110	25055038	NPLG-2P29
P111	25055045	NPLG-4P33
P112	25055146	NPLG-2P130
Sockets		
P102A	2009990150B	NSAS-10P0150
P107A	2009990148A	NSAS-19P148
Switch		
P941	25035558	△NPS-111-L520P
Radiator		
	27160220	RAD51(B)
IC protectors		
QF101,QF102	252112	△ICPN15<G>
Cover		
C941a	27301216	△SB1925A<G>
Clamp		
	27301186	

OPTO. OUTPUT PC BOARD (NADG-3942-2)

CIRCUIT NO.	PART NO.	DESCRIPTION
Q707	24120031	TOTX178,Photocoupler
L701	230906	BL02RN2-R62,Core
C717	354722219	220 μF,6.3V,Elect.capacitor
P708	25045172	HSJ1003-01-020,JackRI

<G> :Except 120V model

NOTE: THE COMPONENTS IDENTIFIED BY MARK △ ARE CRITICAL FOR RISK OF FIRE AND ELECTRIC SHOCK. REPLACE ONLY WITH PART NUMBER SPECIFIED.

PRINTED CIRCUIT BOARD VIEW FROM BOTTOM SIDE

DISPLAY CIRCUIT PC BOARD (NADIS-3943-2/2A)

CIRCUIT NO.	PART NO.	DESCRIPTION
	ICs	
Q701	22240367B	CXP50116-192Q (Use IC CXP50116-192Q instead of CXP50116-155Q and CXP50116-179Q)
Q705	222963 or 22240322	LB1630 or LB1639
	FL tube	
Q702	212087	16-BT-21GK
	Transistors	
Q703, Q704	2212132 or 2212133	2SC2021-R or 2SC2021-S
Q706	2212600 or 2213580	DTA124ES or RN2203
	Diodes	
D701	224450562	MTZ5.6B
D702	224450623	MTZ6.2C
D703-D705	223163	1SS133
	Capacitors	
C701	354764709	47 μ F, 35V, Elect.
C721	354744709	47 μ F, 16V, Elect.
	Switches	
S701-S730	25035548	NPS-111-S510
	Sockets	
P101A	2006391255	NSAS-12P0159
P105A	2006391850	NSAS-18P0161
P106A	2006391650	NSAS-16P0160
P112A	2000903	NSAS-4P859
P701A	2006391010	NSAS-10P0158
P703A	2009990149B	NSAS-6P0149
	Holder	
	27190778	

OUTPUT LEVEL VOLUME PC BOARD (NAAF-3844-2)

CIRCUIT NO.	PART NO.	DESCRIPTION
R607, R608	5104242or 5104280	N16RGM20KB30F, Variable resistor (Modification type: High speed type)
S731	25030331	NRSF-123-30SRRU, Rotary switch
P403A	2009990147A	NSAS-12P0147, Socket
P404A	2009990146A	NSAS-10P0146, Socket
P701	25055149	NPLG-5P133, Plug

AUDIO CIRCUIT PC BOARD (NAAF-3945-2)

CIRCUIT NO.	PART NO.	DESCRIPTION
L601-L603	230906	BL02RN2-R62, Core
P402	25045139	HLJ0540-01-010, Stereo headphone jack
P405	2009990145A	NSAS-8P0145, Socket

REMOTE CONTROL SENSOR PC BOARD (NAETC-3946-2)

CIRCUIT NO.	PART NO.	DESCRIPTION
U701	24130003	GP1U50XS, Remote control sensor
C713	354744709	47 μ F, 16V, Elect. capacitor

POWER INDICATOR PC BOARD (NAETC-3947-2)

CIRCUIT NO.	PART NO.	DESCRIPTION
D706, D707	225142 27190454A	SEL2913K, LED Holder

PACKING VIEW

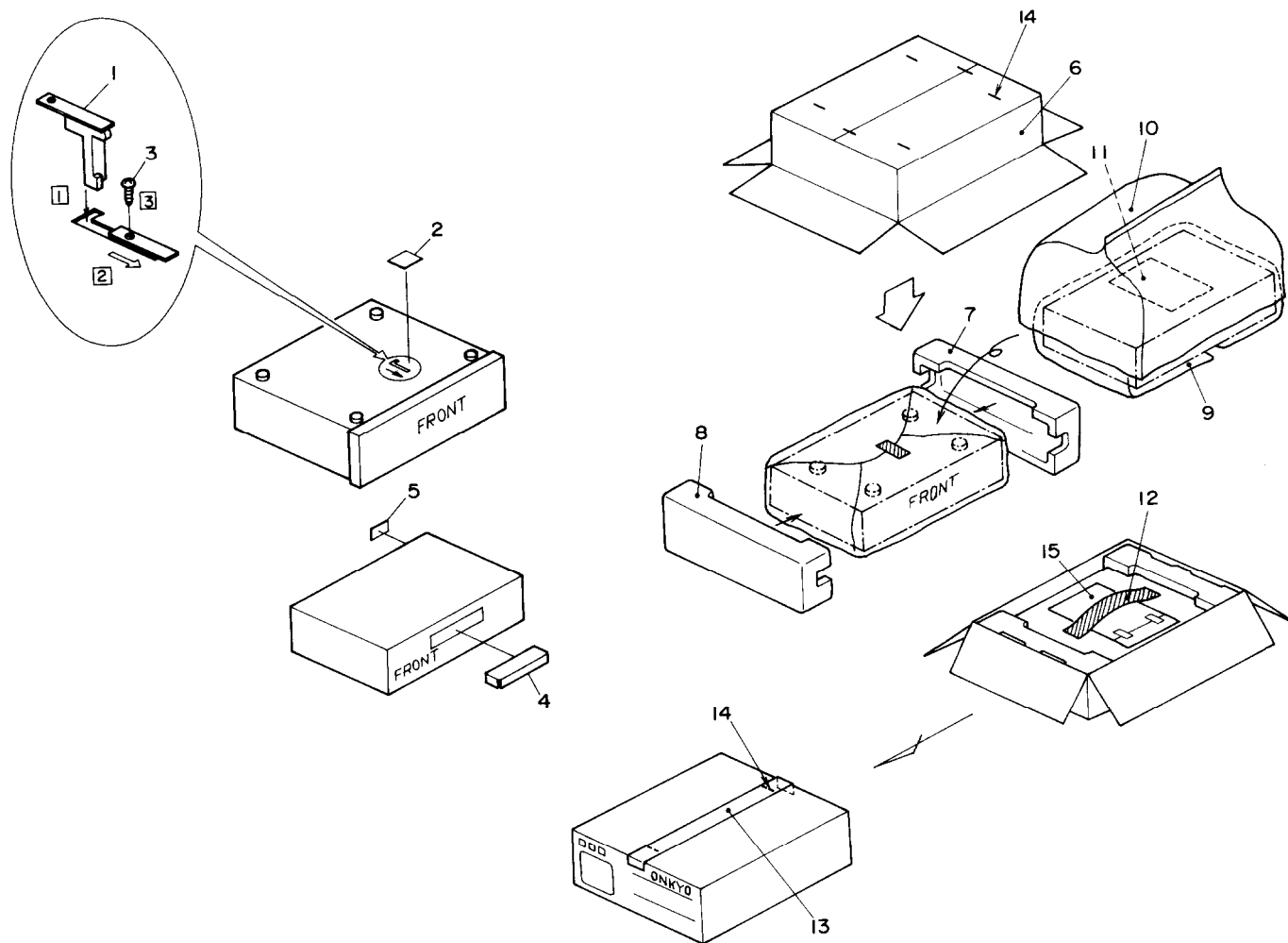

REF. NO.	PART NO.	DESCRIPTION
1	28335034A	Lock lever
2	29361262	Label
3	834430088	3TTS+8B(BC),Self-tapping screw
4	29095616A	Sheet,door
5	29361301	Label
6	29052100A	Master carton box
7	29091363C	Pad L
8	29091364C	Pad R
9	29095012-1	550×800mm,Protection sheet
10	29100034A	650×850mm,Styrene bag
11	29355165	Caution sheet
12	29110071	Damplon tape
13	29110071-1	Damplon tape
14	282301	Sealing hook

Accessory bag ass'y

2010166	Output signal cord
2010200	RI remote control cable
24140177A	RC-177C,Remote control transmitter
3010054	UM-3,Two batteries
2050022A	Optical fiber cable
29341547	Instruction manual <D>
29341550	Instruction manual <G/DC/W>
29100097	350×250mm,Styrene bag
29100107	Styrene bag for warranty card <GF>
29365019	Warranty card <DN>
29365024	Warranty card <GF>
29358002J	Service station list <DN>
25055040	CV-K-2,Conversion plug <W>

- 1 . Insert the lock lever into the hole on the bottom board as shown above.
- 2 . Move the lock lever to the arrow mark.
- 3 . Tighten the screw to secure the lock lever with a Phillips screwdriver.

NOTE : <D> : Only 120V models
 <G> : Only 220V/240V models
 <W> : Only Worldwide model
 <DN> : Only U.S.A. model
 <DC> : Only Canadian model
 <GF> : Only French model