

ONKYO® SERVICE MANUAL

COMPACT DISC PLAYER MODEL DX-702

Black and silver models

BHMD,BHMDN,BHMDC	120V AC, 60Hz
BHMP,BHMPF,MP,MPF	230V AC, 50Hz
BHMW	120/220V AC, 50/60Hz
BHMQA	240V AC,50Hz

SAFETY-RELATED COMPONENT WARNING!!

COMPONENTS IDENTIFIED BY MARK  ON THE SCHEMATIC DIAGRAM AND IN THE PARTS LIST ARE CRITICAL FOR RISK OF FIRE AND ELECTRIC SHOCK. REPLACE THESE COMPONENTS WITH ONKYO PARTS WHOSE PART NUMBERS APPEAR AS SHOWN IN THIS MANUAL.

MAKE LEAKAGE-CURRENT OR RESISTANCE MEASUREMENTS TO DETERMINE THAT EXPOSED PARTS ARE ACCEPTABLY INSULATED FROM THE SUPPLY CIRCUIT BEFORE RETURNING THE APPLIANCE TO THE CUSTOMER.

SPECIFICATIONS

Signal readout system:	Optical non-contact
Reading rotation:	About 500~200 r.p.m. (constant linear velocity)
Linear velocity:	1.2~1.4m/s
Error correction system:	Cross interleave readsolomon code
Decoded bits:	1 BIT PWM Accu Pulse Quartz System
Sampling frequency:	352.8kHz (8 times oversampling)
Number of channels:	2 (Stereo)
Frequency response:	5Hz~20kHz
Total harmonic distortion:	0.004% (at 1kHz)
Dynamic range:	96dB
Signal to noise ratio:	100dB
Channel separation:	90dB (at 1kHz)
Wow and Flutter:	Below threshold of measurability
Power consumption:	12 watts
Output level:	2 volts r.m.s.
Dimensions (W×H×D):	455×110×305mm 18"×4-3/8"×12"
Weight:	4.9kg. 10.8lbs.

Specifications are subject to change without notice.

ONKYO
AUDIO COMPONENTS

SCHEMATIC DIAGRAM

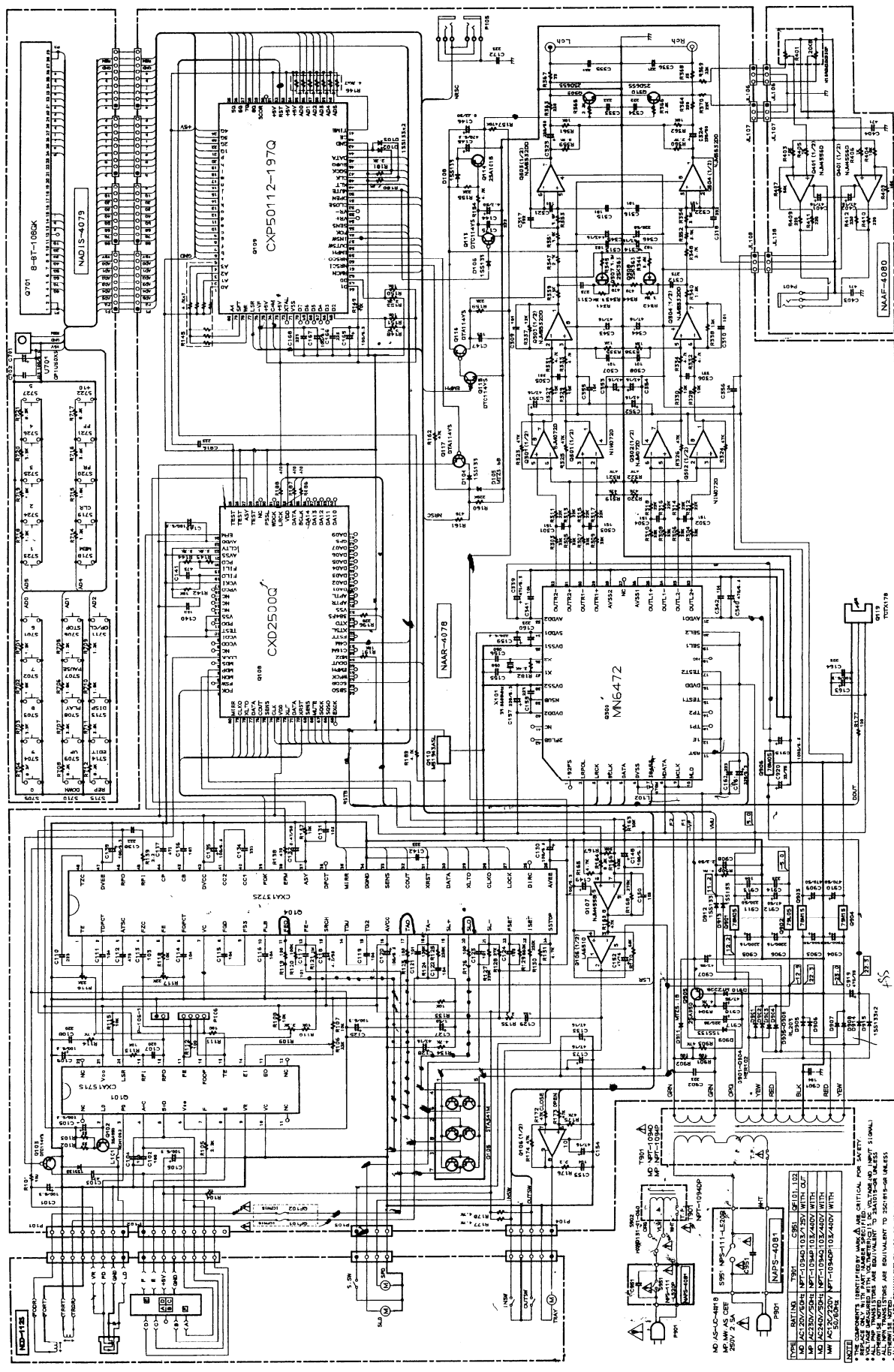

1 2 3 4 5 6

- NOTE: THE COMPONENTS IDENTIFIED BY ANGLES ARE CRITICAL FOR SAFETY. UNLESS OTHERWISE SPECIFIED, ALL PARTS SHOULD BE AS MANUFACTURED BY THE MANUFACTURER (PART NUMBER).
- * ALL PARTS SHOULD BE EQUIVALENT TO SOCIETY'S ADDRESS.
 - * ALL DIMENSIONS ARE IN MILLIMETERS UNLESS OTHERWISE NOTED.
 - * ALL DIMENSIONS ARE IN MILLIMETERS UNLESS OTHERWISE NOTED.
 - * ALL DIMENSIONS ARE IN MILLIMETERS UNLESS OTHERWISE NOTED.
 - * ALL DIMENSIONS ARE IN MILLIMETERS UNLESS OTHERWISE NOTED.
 - * ALL DIMENSIONS ARE IN MILLIMETERS UNLESS OTHERWISE NOTED.
 - * ALL DIMENSIONS ARE IN MILLIMETERS UNLESS OTHERWISE NOTED.
 - * ALL DIMENSIONS ARE IN MILLIMETERS UNLESS OTHERWISE NOTED.
 - * ALL DIMENSIONS ARE IN MILLIMETERS UNLESS OTHERWISE NOTED.
 - * ALL DIMENSIONS ARE IN MILLIMETERS UNLESS OTHERWISE NOTED.
 - * ALL DIMENSIONS ARE IN MILLIMETERS UNLESS OTHERWISE NOTED.

TABLE OF CONTENTS

Specifications	1
Service procedures	2
Note on compact disc	2
Caution of replacement of optical pickup	3
Protection of eyes from laser beam during servicing ...	4
Laser warning label	4
Mechanism exploded view	5
Exploded view	8
Parts list	9
IC block diagrams and descriptions	10
Adjustment procedures	18
Printed circuit board view	21
Pc board-parts list	22
Schematic diagram	23
Block diagram	27
Packing view	28

NOTE ON COMPACT DISC

● Holding Compact Discs

Hold Compact Discs by the edges so that you do not touch the surface of disc. Remember that the side of the disc with the "rainbow" reflection is the side containing the audio information.

Do not attach tape or paper to the label side of the disc and always be careful not to leave fingerprints on the side that is played.

● Storing Compact Discs

Store Compact Discs in a location protected from direct sunlight, high heat and humidity and extremely high and low temperatures. Discs should never be left in the trunk or interior of an automobile in the sun since the temperature can become very high in such a closed environment.

Always store Compact Discs in the holders in which they were sold. Never leave a disc in the player's disc holder for a long period of time.

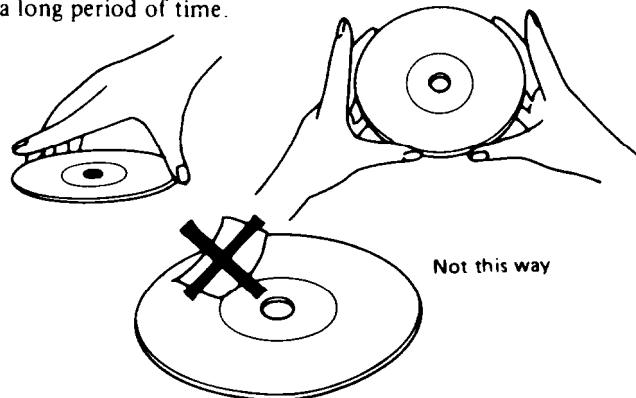

SERVICE PROCEDURES

1. Safety-check out

After correcting the original service problem, perform the following safety check before releasing the set to the customer:

Connect the insulating-resistance tester between the plug of power supply cord and chassis.

Specifications: More than 10Mohm at 500V.

2. Voltage Selector (Back panel)

Worldwide models are equipped with a voltage selector to conform with local power supplies. Be sure to set this switch to match the voltage of the power supply in user's area before turning the power switch on.

Voltage is changed by sliding the groove in the switch with a screw driver to the right or left.

Confirm that the switch has been moved all the way to the right or left before turning the power switch on.

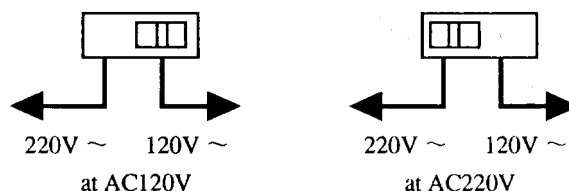

● Cleaning Compact Discs

Before playing a disc wipe off the playing surface with a soft cloth to remove dust and other soil. Wipe the surface in straight lines from the center of the disc outward, not in a circular motion as you would with a phonograph record.

Do not use benzene, chemical cleansers or phonograph record cleaning solutions to clean Compact Discs. Also avoid static electricity prevention solutions since they can damage the surface of Compact Discs.



Fig. 9

Problems Caused by Dew

Dew can form inside a Compact player when it is brought from a cold environment into a warm room, when a room is rapidly heated and if a player is left in a humid environment.

This dew can prevent the laser pickup from reading the data contained in the pits in the disc surface. If the player does not operate properly because of dew, remove the disc and leave the player's power switch on for about one hour to remove all moisture.

CAUTION ON REPLACEMENT OF OPTICAL PICKUP

The laser diode in the optical pickup block is so sensitive to static electricity, surge current and etc, that the components are liable to be broken down or its reliability remarkably deteriorated.

During repair, carefully take the following precautions. (The following precautions are included in the service parts.)

PRECAUTIONS

1. Ground for the work-desk.

Place a conductive sheet such as a sheet of copper (with impedance lower than $10M\Omega$) on the work-desk and place the set on the conductive sheet so that the chassis.

2. Grounding for the test equipment and tools.

Test equipments and toolings should be grounded in order that their ground level is the same the ground of the power source.

3. Grounding for the human body.

Be sure to put on a wrist-strap for grounding whose other end is grounded.

Be particularly careful when the workers wear synthetic fiber clothes, or air is dry.

4. Select a soldering iron that permits no leakage and have the tip of the iron well-grounded.

5. Do not check the laser diode terminals with the probe of a circuit tester or oscilloscope.

Care Should be taken with the optical pickup.

The optical pickup is sensitive to static electricity, surge currents, and other high electrical noise, and because there is the possibility of damage to performance, in the handling of the pickup, the utmost care must be taken, particularly with regard to static electricity.

1. When checking the laser terminal, avoid making connections using the probes of a tester or oscilloscope, or an ordinary power supply.
2. When replacing the optical pickup, first short the LD terminals and remove the connector. Also, when attaching the new optical pickup, after attaching the connector, unsolder the LD terminals.

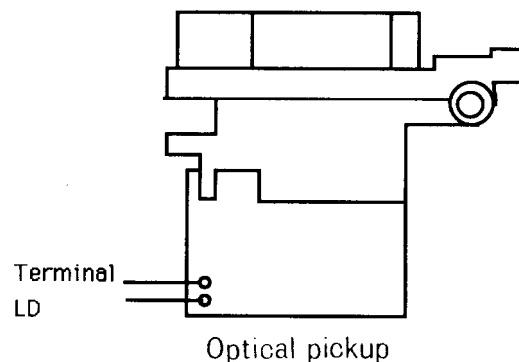

PROTECTION OF EYES FROM LASER BEAM DURING SERVICING

This set employs a laser. Therefore, be sure to follow carefully the instructions below when servicing.

WARNING!!

WHEN SERVICING, DO NOT APPROACH THE LASER EXIT WITH THE EYE TOO CLOSELY. IN CASE IT IS NECESSARY TO CONFIRM LASER BEAM EMISSION, BE SURE TO OBSERVE FROM A DISTANCE OF MORE THAN 30cm FROM THE SURFACE OF THE OBJECTIVE LENS ON THE OPTICAL PICK-UP BLOCK.

LASER WARNING LABEL

The label shown below are affixed.

1. Warning label

This label is located on the arm of mechanism.

- (A) **DANGER** —INVISIBLE LASER RADIATION WHEN OPEN AND INTERLOCK FAILED OR DEFEATED. AVOID DIRECT EXPOSURE TO BEAM
- CAUTION** —HAZARDOUS LASER AND ELECTROMAGNETIC RADIATION WHEN OPEN AND INTERLOCK DEFEATED.
- ATTENTION** —RAYONNEMENT LASER ET ELECTROMAGNETIQUE DANGEREUX SI OUVERT AVEC L'ECLANCHEMENT DE SECURITE ANNULE.

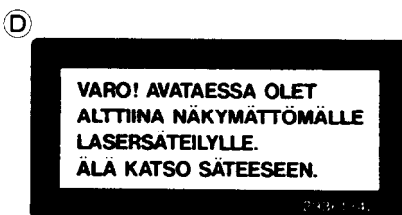
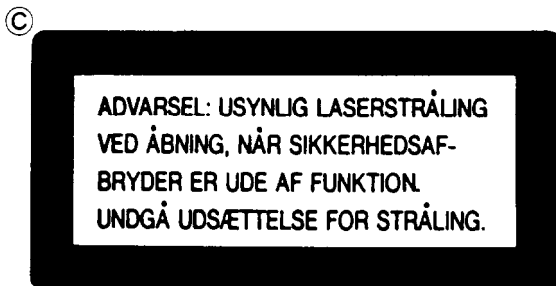
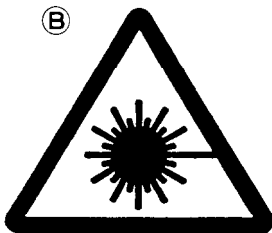

- (A) : Danger label
 (B) : Except 120V model
 (C) : Except 120V model
 (D) : Only 230V model

Laser Diode Properties

- Material: GaAS/GaAlAs
- Wavelength: 780nm
- Emission Duration: continuous
- Laser output: max. 0.5mW*

*This output is the value measured at a distance about 1.8mm from the objective lens surface on the Optical Pick-up Block.

2. Certification label (120V model)

This label is located on the back panel.

PRODUCT IS CERTIFIED BY THE MANUFACTURER TO COMPLY WITH DHHS RULES 21 CFR SUBCHAPTER J APPLICABLE AT THE DATE OF MANUFACTURE.



3. Class 1 label (Except 120V model)

This label is located on the back panel.

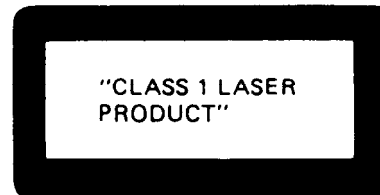

ADVARSEL

Denne mærkning er anbragt på apparatets højre side og indikerer, at apparatet arbejder med laserstråler af klasse 1, hvilket betyder, at der anvendes laserstråler af svageste klasse, og at man ikke på apparatets yderside kan blive udsat for utilladelig kraftig stråling.

APPARATET BØR KUN ÅBNES AF FAGFOLK MED SÆRLIGT KENDSKAB TIL APPARATER MED LASERSTRÅLER!

Indvendigt i apparatet er anbragt den her gengivne advarselsmærkning, som advarer imod at foretage sådanne indgreb i apparatet, at man kan komme til at udsætte sig for laserstråling.

VAROITUS! Laite sisältää laseriodin, joka lähettää (näkyvä-
töntä) silmille vaarallista lasersäteilyä.

MECHANISM-EXPLODED VIEW

PICKUP DRIVE UNIT-EXPLODED VIEW

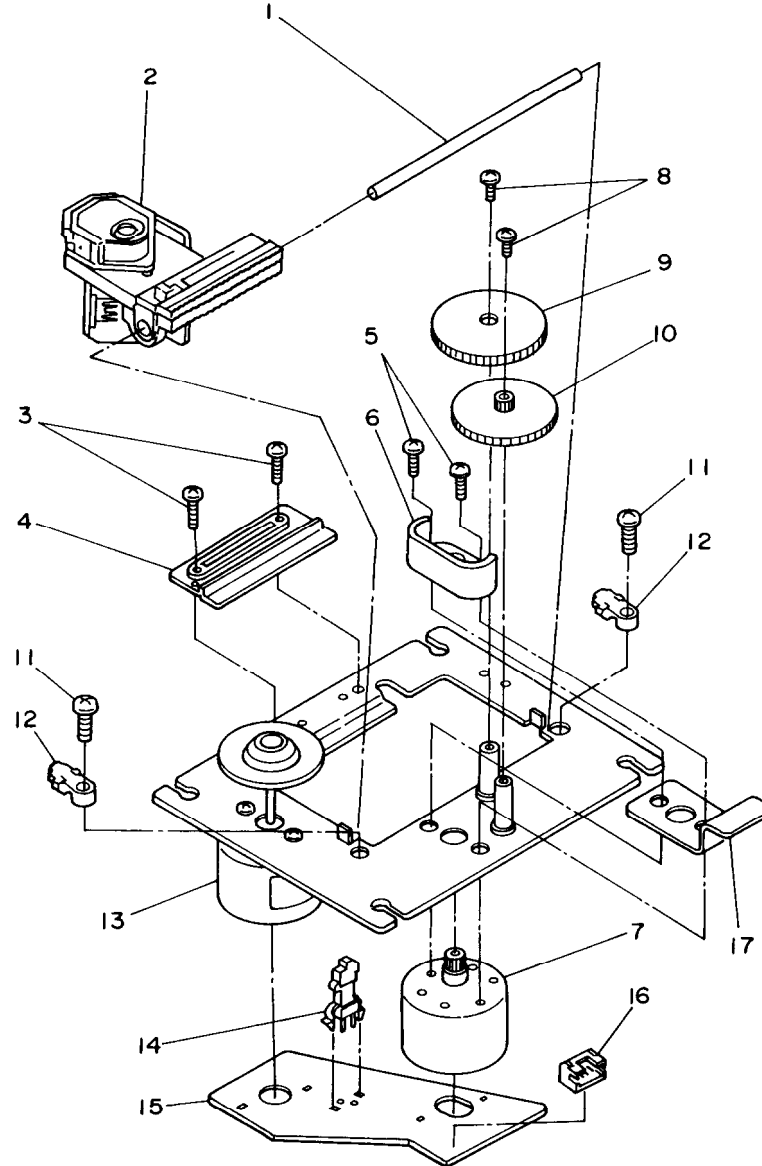

PARTS LIST

REF.NO.	PART NO.	DESCRIPTION	REF.NO.	PART NO.	DESCRIPTION
1	24506900	Slide shaft	10	24506904	Wheel B
2	24110008	KSS-210A,Optical pickup	11	801427	STP2.6×8,Special screw
3	801425	S2×5,Special screw	12	24506905	Shaft clamp
4	24506901	Slide holder	13	24502263	Spindle motor ass'y
5	82112005	P2×5,Pan head screw	14	25065403	NLF-1220,Leafswitch
6	24506902	Gear cover	15	24505271	Motor pc board
7	24502262	Sled motor ass'y	16	25050396	NSCT-4P223,Socket
8	801426	M1.7×3,Special screw	17	24506906	Stopper
9	24506903	Wheel A			

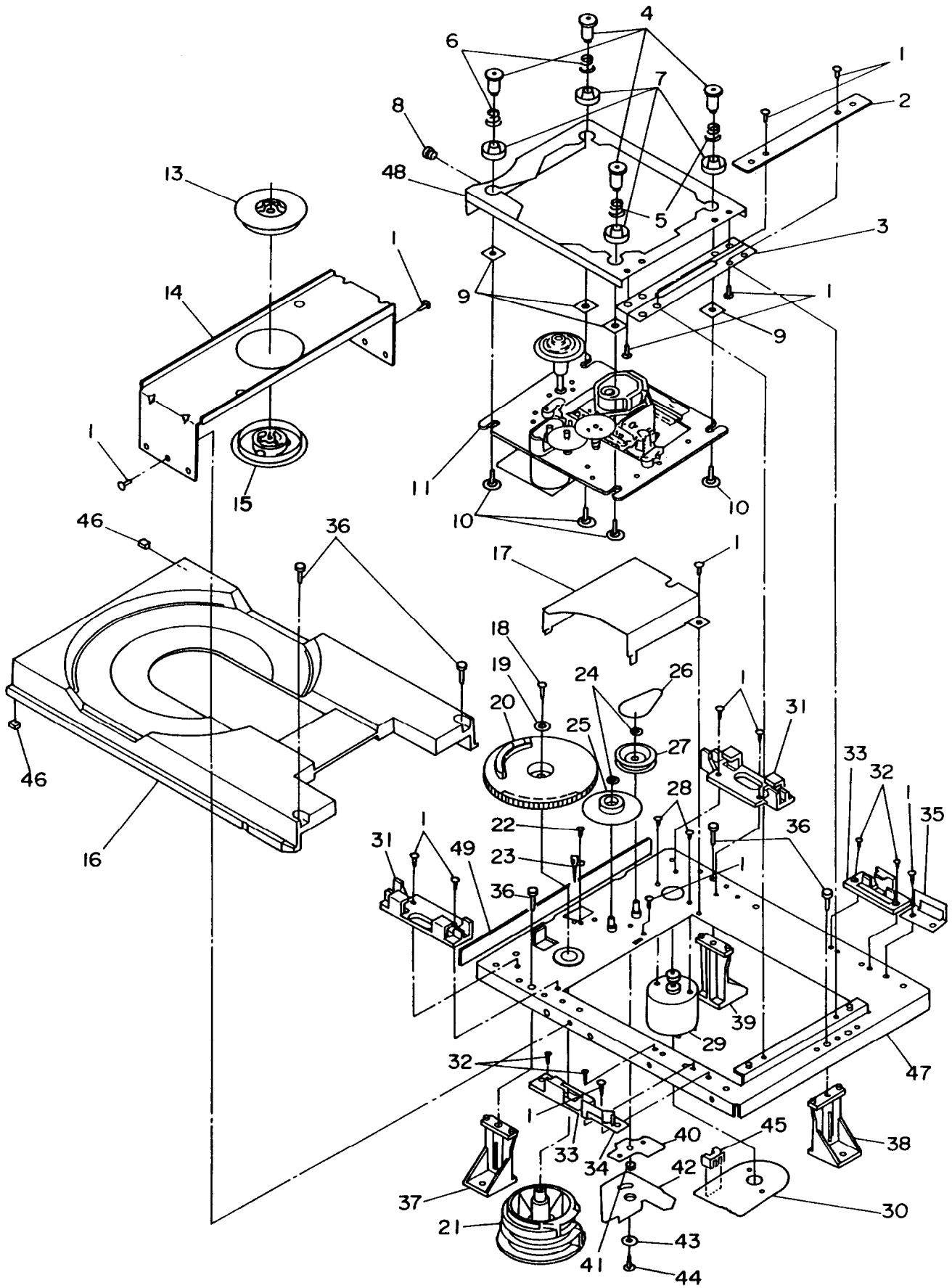

PARTS LIST

REF.NO.	PART NO.	DESCRIPTION	REF.NO.	PART NO.	DESCRIPTION
1	834126069	2.6TTS+6C,Self-tapping screw	26	24602507	Belt
2	24506864	Holder,hinge	27	24506884	Pulley,loading
3	24506865	Hinge	28	838426038	2.6TTB+3C(BC),Self-tapping screw
4	24506866	Shaft	29	24506886	Motor ass'y
5	27180441	Spring	30	24505269	Motor pc board
6	27180442	Spring	31	27301228	Holder,tray
7	24509401	Insulator	32	833120047	2TTP+4S,Self-tapping screw
8	24506870	Roller	33	27301230	Tray holder
9	24506871	Plate	34	24506887	Tray guide R
10	801424	Screw with washer	35	24506888	Tray guide L
11	24506971	KSM-210AFM,Pickup drive unit	36	838430108	3TTB+10B(BC),Self-tapping screw
13	24506875	Magnet	37	24506889	Boss R
14	24506876	Chassis,chucking	38	24506890	Boss B
15	24506959	Pulley,chucking	39	24506891	Boss L
16	24506878	Tray	40	24506892	Link plate
17	24506879	Cover	41	24506893	Boss
18	838426108	2.6TTB+10B(BC),Self-tapping screw	42	24506894	Stopper link
19	8761301008	W3 × 10F,Washer	43	24506895	Spacer
20	24506882	Drive gear	44	83112608	2.6TTW+8S,Self-tapping screw
21	24506883	Control cam	45	25050393	NCNT-5220,Connector
22	834120049	2TTS+4C,Self-tapping screw	46	24506897	Damper
23	25065402	NLF-1219,Leafswitch	47	27301224	Main chassis
24	870114	Washer	48	24506898	Sub chassis
25	27301227	Middle gear	49	28140980	Adhesive tape,front

REMOVEMENT OF DISC TRAY

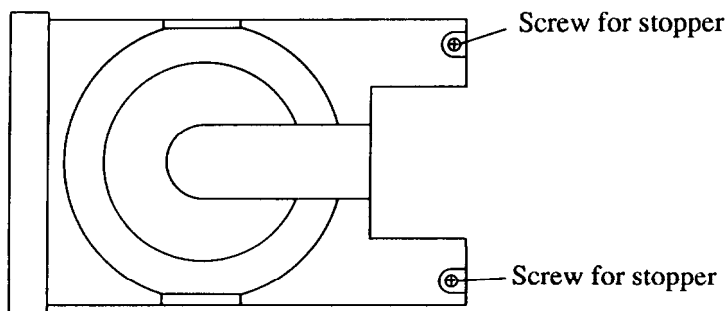

1. Loosen the screw for stopper until the head of screw and the tray are the same height.
2. Turn POWER switch to on.
3. Press OPEN/CLOSE button to open the tray.
4. Turn POWER switch to off.
5. Remove the tray.

CHASSIS-EXPLODED VIEW

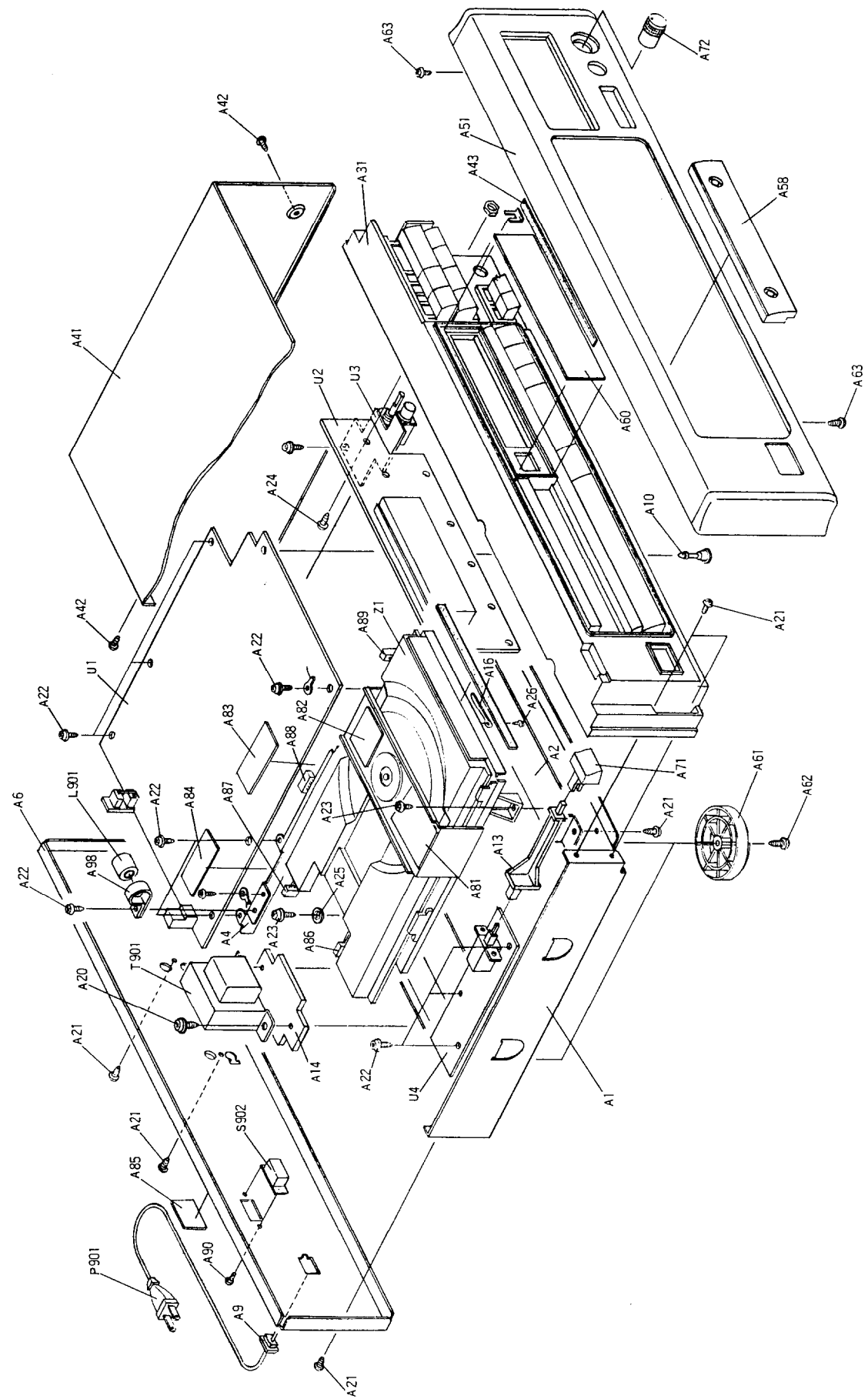

PARTS LIST

REF. NO.	PART NO.	DESCRIPTION	REF. NO.	PART NO.	DESCRIPTION
A1	27100227AY	Chassis	A85	29360687	Label CLASS1 <P/W/Q>
A2	27141436AY	Bracket F	A86	2000951	NSAS-8P903,Socket
A3	27141437Y	Bracket R	A87	2000952	NSAS-8P904,Socket
A4	27130642Y	Bracket C	A88	2002390810	NSAS-8P0120,Socket
A6	27121394Y	Back panel <D>	A89	2002391020	NSAS-10P0119,Socket
	27121395Y	Back panel <P>	A90	82143006	3P+6FN(BC),Pan head screw <W>
	27121396Y	Back panel <W>	A97	2061112100Y	Cord ass'y
	27121419Y	Back panel <Q>	A98	260221	NK-10N,Clamp
A9	27300750	△ Bushing	A99	260208	Binder
A10	27190524	KGLS-14R,Holder	L901	230907	△ TR-16-8-16,Core
A13	27273134Y	Joint,power	P901	253112A	△ AS-UC-4#18,Power supply cord <D>
A14	27270214B	Spacer		253164Y	△ AS-CEE250V2.5A,Power supply cord <P/W>
A16	27255004	CS-1U,Clip			
A20	830440109	4TTC+10C(BC),Self-tapping screw	S902	253118	△ AS-SAA,Power supply cord <Q>
A21	834430088	3TTS+8B(BC),Self-tapping screw		25065123	△ NSS-1258P,Voltage selector switch <W>
A22	831130088	3TTW+8B,Self-tapping screw	T901	2300619Y	△ NPT-1094D,Power transformer <D>
A23	834430108	3TTS+10B(BC),Self-tapping screw		2300620Y	△ NPT-1094P,Power transformer <P>
A24	833430080	3TTP+8P(BC),Self-tapping screw		2300622Y	△ NPT-1094DP,Power transformer <W>
A25	87643010	W3×10F(BC),Washer		2300621Y	△ NPT-1094Q,Power transformer <Q>
A26	834426068	2.6TTS+6B(BC),Self-tapping screw	U1	1H147578-1	NAAR-4078-1,Main circuit pc board ass'y <D>
A31	27110596AY	Front bracket ass'y 			
	27110598AY	Front bracket ass'y <S>			
A41	28184469Y	Top cover		1H147578-1A	NAAR-4078-1a,Main circuit pc board ass'y <P/W/Q>
A42	834430088	3TTS+8B(BC),Self-tapping screw	U2	1H147579-1	NADIS-4079-1,Display circuit pc board ass'y
A43	28140680	0.5×8×180,Cushion			
A51	1H147121	Front panel ass'y 	U3	1H147580-1	NAAF-4080-1,Headphone amplifier pc board ass'y
	1H148121	Front panel ass'y <S>			
	28125222Y	End cap L	U4	1H147581-1	NAPS-4081-1,Power supply pc board ass'y
	28125223Y	End cap R	Z1	24506957Y	NCD-112S,CD mechanism ass'y
A58	27211245Y	Tray panel 			
	27211258	Tray panel <S>			
A60	28191574Y	Clear plate			
A61	27175254Y	Leg			
A62	834430088	3TTS+8B(BC),Self-tapping screw			
A63	833430080	3TTP+8P(BC),Self-tapping screw			
A71	28324140Y	Knob,power 			
	28324184	Knob,power <S>			
A72	28324150	Knob,level 			
	28324151	Knob,level <S>			
A81	29360807	Label DANGER			
A82	29361218Y	Label LASER <P/W/Q>			
A83	29360811AY	Label <P>			
A84	29361298	Label SEM <P>			

NOTE::Only Black Model
 <S>:Only Silver Model
 <D>:Only 120V Model
 <P>:Only 230V Model
 <W>:Only Worldwide Model
 <Q>:Only 240V Model

NOTE: THE COMPONENTS IDENTIFIED BY MARK △ ARE CRITICAL FOR RISK OF FIRE AND ELECTRIC SHOCK. REPLACE ONLY WITH PART NUMBER SPECIFIED.

IC BLOCK DIAGRAM AND DESCRIPTIONS

CXA1571S (RF Amp)

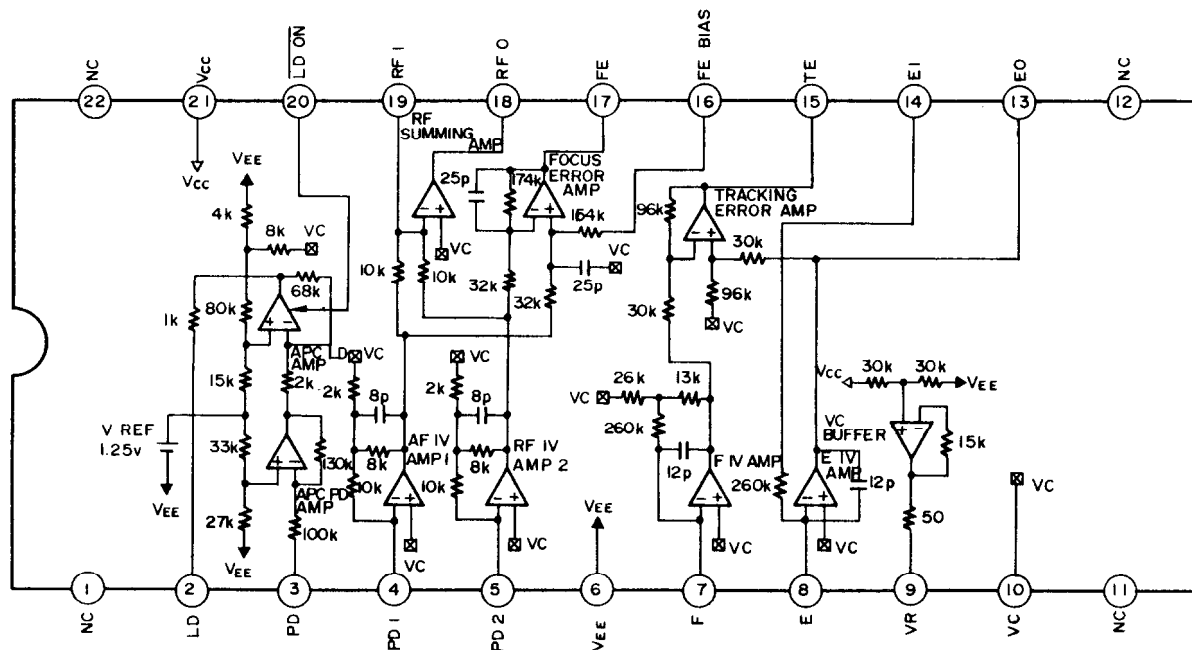

Pin No.	Symbol	I/O	Description
2	LD	O	Output terminal of APC amplifier.
3	PD	I	Input terminal of APC amplifier.
4	PD1	I	Inversion input terminal for RF I-V amplifier. Connect to photo diode A+C.
5	PD2	I	Inversion input terminal for RF I-V amplifier. Connect to photo diode B+D.
7	F-IN	I	Inversion input terminal for F I-V amplifier. Connect to photo diode F.
8	E-IN	I	Inversion input terminal for E I-V amplifier. Connect to photo diode E.
9	VR	O	DC voltage output of $(V_{CC}+V_{EE})/2$.
10	VC	I	Middle point voltage input terminal.
13	EO	O	Monitor output terminal for I-V amplifier E.
14	EI	-	Gain adjustment terminal for I-V amplifier E.
15	TE	O	Tracking error amplifier output terminal. The signal E-F is output from this terminal.
16	FE-BIAS	I	Bias adjustment terminal for non-inversion side of focus error amplifier.
17	FE	O	Focus error amplifier output terminal.
18	RFO	O	RF amplifier output terminal.
19	RFI	I	Inversion input terminal of RF amplifier.
20	LD-ON	I	Change-over terminal for APC amplifier.

CXA1372S (Servo Signal Processor)

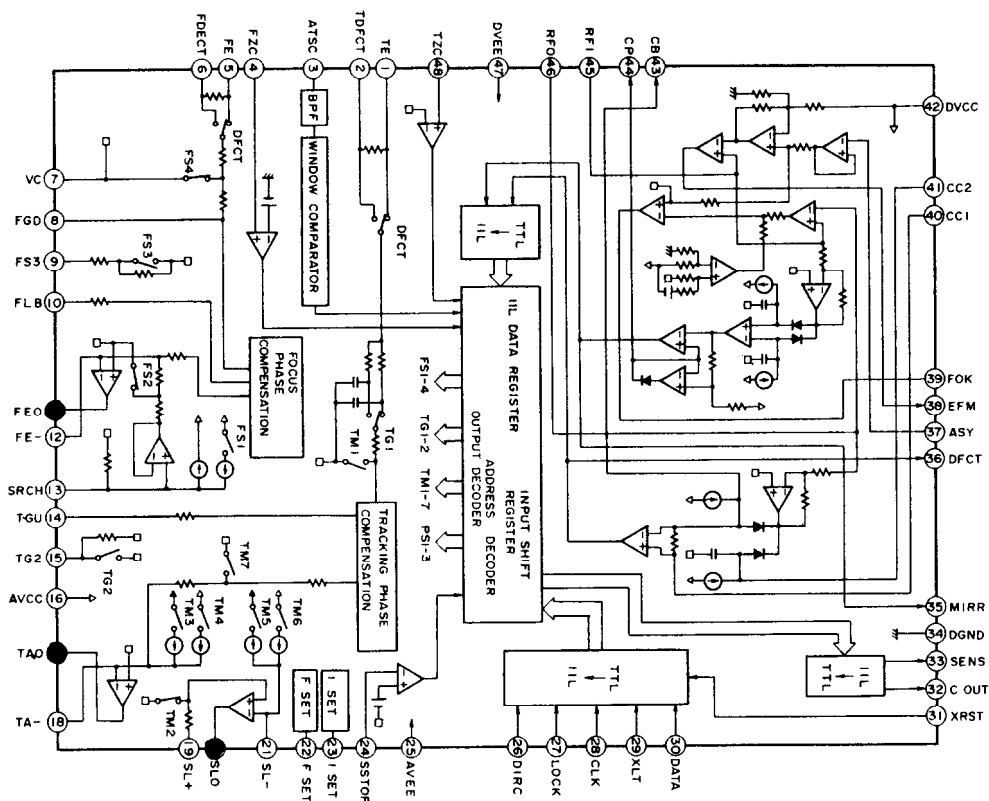

PIN. NO.	SYMBOL	I/O	DESCRIPTION	PIN. NO.	SYMBOL	I/O	DESCRIPTION
1	TE	I	Tracking error input terminal.	22	FSET	I	Peak setting input of phase correction of focus tracking.
2	TDFCT	I	Capacitor connection terminal for time constant when defect.	23	ISET	I	This terminal is flowed the current so that the focus search, tracking jump, and sled kick height is decided.
3	ATSC	I	Window comparator input terminal for ATSC detection.	24	SSTOP	I	Inner switch selection input terminal.
4	FZC	I	Focus zero-cross comparator input terminal.	26	DIRC	I	This terminal is used when a track jump.
5	FE	I	Focus error input terminal.	27	LOCK	I	The sled runaway prevention circuit operates at the low level.
6	FDFCT	I	Capacitor connection terminal for time constant when defect.	28	CLK	I	Serial data transfer clock input from microprocessor.
7	VC	I	Mid-point voltage input terminal.	29	XLT	I	Latch input from microprocessor.
8	FGD	I	Connect the capacitor between pin 9 and this pin when the high frequency gain of focus servo is dropped.	30	DATA	I	Serial data input from microprocessor.
9	FS3	I	Focus servo high frequency gain changeover input terminal.	31	XRST	I	Reset input terminal. Active low.
10	FLB	I	Input terminal for the low frequency boost of focus servo.	32	C. OUT	O	Signal output to count the track numbers.
11	FEO	O	Focus drive output terminal.	33	SENS	O	This terminal outputs FZC, and SSTOP to according command from microprocessor.
12	FE-	I	Inversion input terminal of focus amplifier.	35	MIRR	O	Mirror comparator output terminal.
13	SRCH	I	Time constant terminal to make the focus search waveform.	36	DFCT	O	Defect comparator output terminal.
14	TGU	I	Tracking high frequency gain changeover input terminal.	37	ASY	I	Auto asymmetry control input terminal.
15	TG2	I	Tracking high frequency changeover input terminal.	38	EFM	O	EFM comparator output terminal.
17	TAO	O	Tracking drive output terminal.	39	FOK	O	Focus OK comparator output terminal.
18	TA-	I	Inversion input terminal of tracking amplifier.	40	CC1	O	Defect bottom hold output terminal.
19	SL+	I	No-inversion input terminal of sled amplifier.	41	CC2	I	Defect bottom hold input terminal from CC1.
20	SLO	O	Sled (slide) drive output terminal.	43	CB	I	Defect bottom hold capacitor connection terminal.
21	SL-	I	Inversion input terminal of sled amplifier.	44	CP	I	Mirror hold capacitor connection terminal.
				45	RFI	I	RF summing amplifier input terminal.
				46	RFO	O	RF summing amplifier output terminal.
				48	TZC	I	Tracking zero-cross comparator input terminal.

CXD2500Q (Digital Signal Processor)

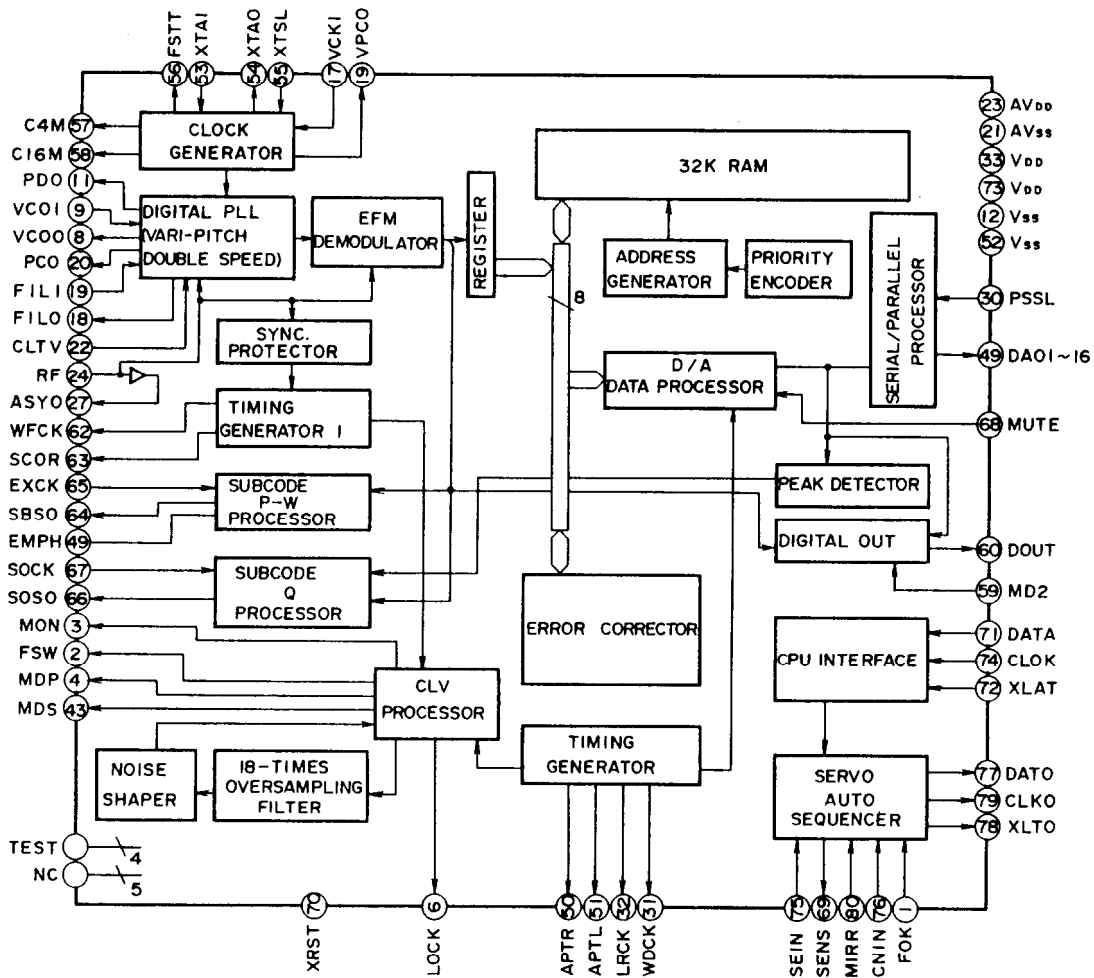

NO.	SYMBOL	I/O	DESCRIPTION	NO.	SYMBOL	I/O	DESCRIPTION
1	FOK	I	Focus OK input	42	DA08	O	GFS output
2	FSW	O	Output filter changeover output of spindle motor	43	DA07	O	RFCK output
3	MON	O	Spindle motor control output	44	DA06	O	C2P0 output
4	MDP	O	Spindle motor servo control	45	DA05	O	XRAOF output
5	MDS	O	Spindle motor servo control	46	DA04	O	MNT3 output
6	LOCK	O	H when GFS is high	47	DA03	O	MNT2 output
7	NC			48	DA02	O	MNT1 output
8	VCOO	O	Oscillation circuit output for analog FEM PLL	49	DA01	O	MNT0 output
9	VCOI	I	Oscillation circuit input for analog EFM PLL (8.6436MHz)	50	APTR	O	Control output for aperture correction. H when Rch.
10	TEST	I	Test terminal	51	APT1	O	Control output for aperture correction. H when L.ch.
11	PDO	O	Charge pump output for analog EFM PLL	52	Vss		Ground
12	Vss		Ground terminal	53	XTAI	I	Crystal oscillation circuit input of 16.9344MHz or 33.8688MHz input
13-15	NC			54	XTAO	O	Crystal oscillation circuit output of 16.9344MHz
16	VPCO	O	PLL charge pump output for variable pitch	55	XTSI	I	Crystal selection input terminal. L when 16.9344MHz. H when 33.8688MHz.
17	VCKI	I	Clock input for variable pitch from VCO (16.934MHz)	56	FSTT	O	2/3 divided output of pins 53 & 54
18	FILO	O	Filter output for master PLL	57	C4M	O	4.2336MHz output
19	FILI	I	Filter input for master PLL	58	C16M	O	16.9344MHz output
20	PCO	O	Charge pump output for master PLL	59	MD2	I	Digital output control input. On at H & Off at L.
21	AVss		Analog ground	60	DOUT	O	Digital output
22	CLTV	I	VCO control voltage input for master	61	EMPH	O	Emphasis control output. Active H.
23	AVDD		Analog section power supply (+5V)	62	WFCK	O	Write frame clock output
24	RF	I	EFM signal input	63	SCOR	O	Sub-code detection output. H when is detected S0 or S1.
25	TEST2	I	Connect to the ground.	64	SBSO	O	Serial output of sub code (P~W)
26	TEST3	I	Connect to the ground.	65	EXCK	I	Clock input for read out SBSO
27	ASYO	O	EFM full swing output	66	SQSO	O	Sub Q 80 bits. PCM peak. and level data 16 bits output
28	TEST4	I	Connect to the ground.	67	SQCK	I	Clock input for read out SQSO
29	NC			68	MUTE	O	Muting control output. Active H.
30	PSSL	I	Audio data output mode changeover input. Serial data at L and parallel data at H.	69	SENS	-	Sens output. Output to microprocessor
31	WDCK	O	D/A interface for 48 bits slot. Word clock f=2Fs.	70	XRST	I	System reset. Rest at low level.
32	LRCK	O	D/A interface for 48 bits slot. LR clock f=Fs.	70	DATA	I	Serial data input from microprocessor
33	VDD		Power supply terminal (+5V)	72	XLTA	I	Latch input from microprocessor. Latch the serial data at trailing.
34-49			Data output terminals	73	VDD		Power supply
			PSSL=1 PSSL=0	74	CLOCK	I	Serial data transfer clock input from microprocessor
34	DA16	O	DA16 Serial data of 48 bits slot	75	SEIN	I	Sens input from SSP
35	DA15	O	DA15 Bit clock of 48 bits slot	76	CNCI	I	Track jump numbers count signal input
36	DA14	O	DA14 Serial data of 64 bits slot	77	DATO	O	Serial data output to SSP
37	DA13	O	DA13 Bit clock of 68 bits slot	78	XLTO	O	Serial data latch output to SSP. Latch at trailing.
38	DA12	O	DA12 LR clock of 68 bits slot	79	CLKO	O	Serial data transfer clock output to SSP
39	DA11	O	DA11 GTOP output	80	MIRR	I	Mirror signal input
40	DA10	O	DA10 XUGF output				
41	DA09	O	DA09 XPLCK output				

Note:SSP:Q104 CXA1372S

CXP50112 -197Q (Microprocessor)

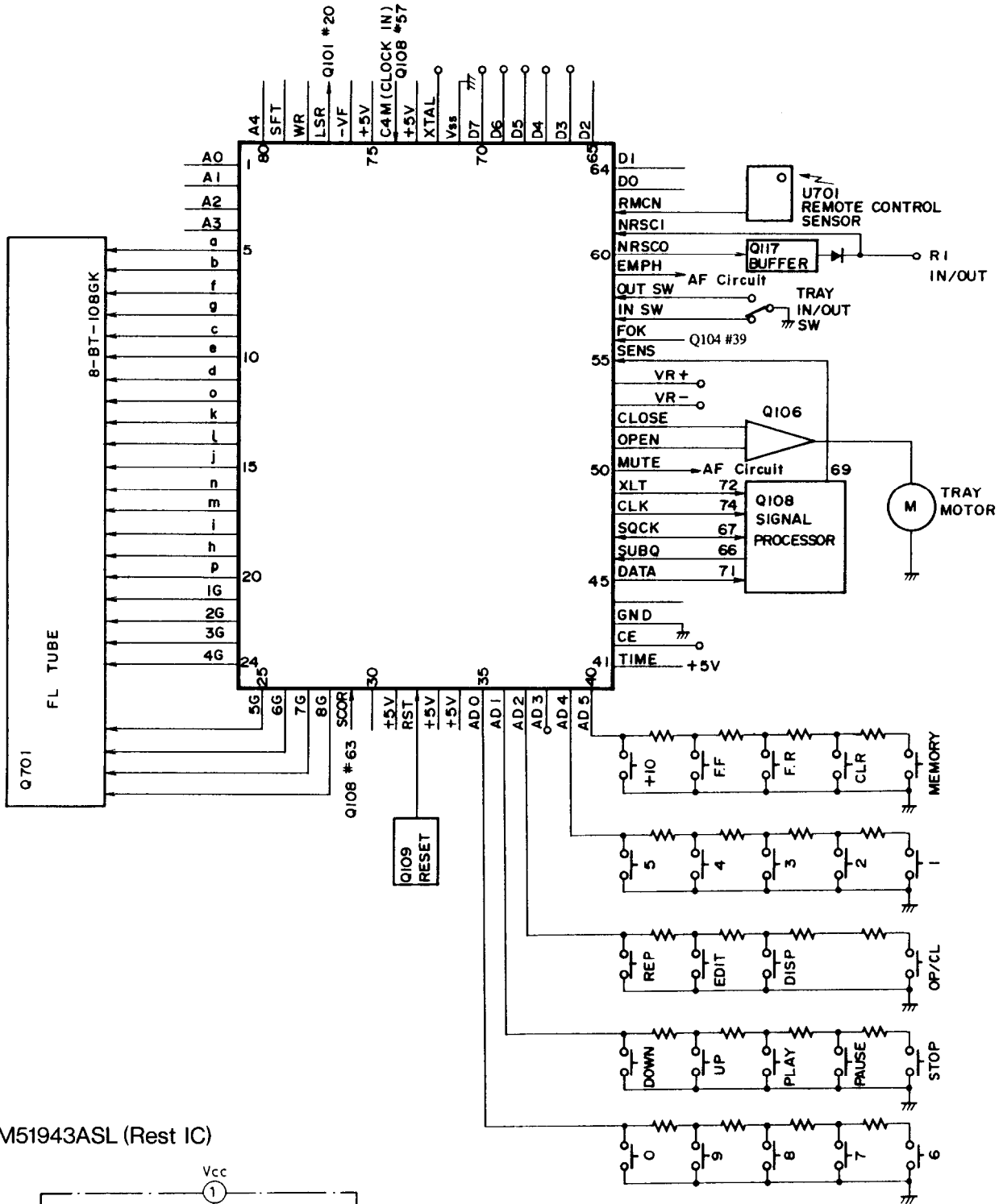

M51943ASL (Rest IC)

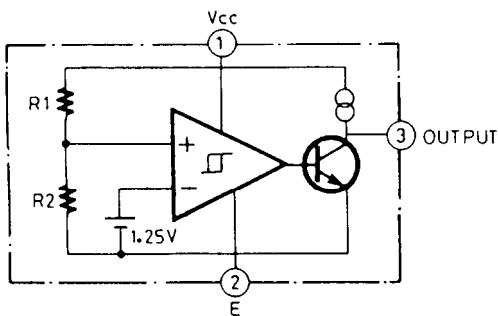

Pin No.	Symbol	Description
1 ~ 4	A0 ~ A3	Music file control signal.Not used.
5 ~ 20	a ~ p	Fluorescent indicator tube segment drive output terminals.
21 ~ 28	1G ~ 8G	Fluorescent indicator tube grid drive output terminals.
29	SCOR	Synchronizing signal detection input terminal of sub code frame.
31	5V	
32	RST	Reset input terminal.Reset at the low level.
33,34	5V	
35 ~ 40	AD0 ~ AD5	AD input terminal.Connect to the operation key.
41	TIME	Timer switch connection terminal.Not used.
42	CE	Chip enable terminal.
43	GND	
45	DATA	Serial data output terminal.
46	SUBQ	Subcode Q input terminal.
47	SQCK	Subcode Q read clock input/output terminal.
48	CLK	Serial data transmission clock output terminal.
49	XLT	Command execution output terminal.
50	MUTE	Muting ON/OFF control output terminal.ON at the high level.
51	OPEN	Tray open control output terminal.Open at the low level.
52	CLOSE	Tray close control output terminal.Close at the low level.
53	VR-	Volume control output.Not used.
54	VR+	Volume control output.Not used.
55	SENS	Interface of signal processor and microprocessor ICs.
56	FOK	Focus OK input terminal.Focus OK at the high level.
57	INSW	Tray close detection input terminal.
58	OUTSW	Tray open detection input terminal.
59	EMPH	Emphasis ON/OFF control output terminal.On at the high level.
60	NRSCO	Remote control signal (RI signal) output terminal.
61	NRSCI	Remote control signal (RI signal) input terminal.
62	RMCN	Remote control signal input terminal.
63 ~ 70	D0 ~ D7	Music file control signal.Not used.
71	Vss	Ground terminal.
72	XTAL	Clock output terminal.
73	5V	
74	C4M	System clock input terminal.
75	5V	
76	VF	Negative power supply terminal for fluorescent indicator tube.
77	LSR	Optical pickup control output terminal.On at the low level.
78	WR	Music file control signal.Not used.
79	SFT	Music file control signal.Not used.
80	A4	Music file control signal.Not used.

MN6472 (D/A Converter)

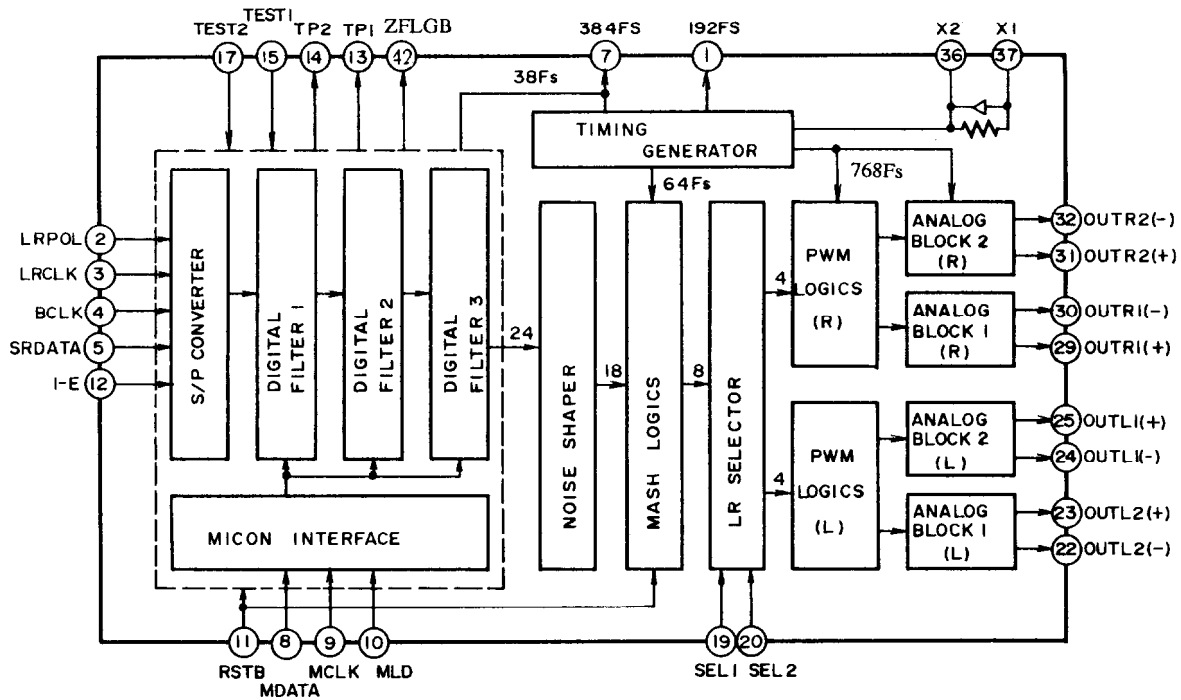

Pin No.	Symbol	Description	Pin No.	Symbol	Description
1	192FS	192FS(=8.4672MHz) output terminal.	21	AVDD1	Power supply terminal 1 for analog system. (+5V)
2	LRPOL	Polarity switching terminal for LRCLK.L ch at "H",R ch at "L".	22	OUTL2(-)	PWM output terminal for L 2 ch negative phase.
3	LRCLK	Input terminal for LRCLK. At LR-POL "H":Lch data input at "H",Rch data input at "L". At LR-POL "L":Lch data input at "L",Rch data input at "H".	23	OUTL2(+)	PWM output terminal for L 2 ch positive phase.
4	BCLK	Serial bit clock input terminal.	24	OUTL1(-)	PWM output terminal for L 1 ch negative phase.
5	SRDATA	Input terminal for serial input data.	25	OUTL1(+)	PWM output terminal for L 1 ch positive phase.
6	DVSS	Ground terminal for digital system.	26	AVSS1	Ground terminal 1 for analog system.
7	384FS	384FS=16.9344MHz output terminal. •	27	NC	
8	MDATA	Microprocessor command data input terminal.	28	AVSS2	Ground terminal 2 for analog system.
9	MCLK	Clock input terminal for microprocessor command.	29	OUTR1(+)	PWM output terminal for R 1 ch positive phase.
10	MLD	Microprocessor command load input terminal.Load at "L".	30	OUTR1(-)	PWM output terminal for R 1 ch negative phase.
11	RSTB	Reset terminal.Reset at "L".	31	OUTR2(+)	PWM output terminal for R 2 ch positive phase.
12	I-E	Signal processing LSI format at "L",and I ² S format at "H".	32	OUTR2(-)	PWM output terminal for R 2 ch negative phase.
13	TP1	Output terminal 1 for digital filter portion test.	33	AVDD2	Power supply terminal 2 for analog system. (+5V)
14	TP2	Output terminal 2 for digital filter portion test.	34	DVDD1	Power supply terminal 1 for digital system. (+5V) (Power supply for oscillation circuit)
15	TEST1	Test signal input terminal 1 for testing digital filter portion. Normally "L".	35	DVSS1	Ground terminal 1 for digital system. (Ground for oscillation circuit)
16	DVDD	Power supply terminal for digital system. (Terminal for COM potential fixing) (+5V)	36	X2	Crystal oscillation terminal.
17	TEST2	Test signal input terminal 2 for testing digital filter portion. Normally "L".	37	X1	Crystal oscillation terminal.(External clock input terminal)
18	NC		38	DVSS2	Ground terminal 2 for digital system.
19	SEL1		39	NSUB	Connect to D-VDD.(Potential fixing terminal for Silicon circuit board)
20	SEL2		40	DVDD2	Power supply terminal 2 for digital system. (+5V)
			41	NC	
			42	ZFLGB	Output terminal for zero output detector.

SEL1	SEL2	Output
L	L	Normal stereo output
L	H	Only Lch output
H	L	Only Rch output
H	H	Both Rch and Lch negative output

STA341M-L (Transistor Array)

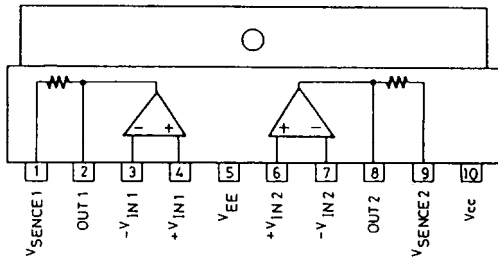

LA6510 (Power OP Amp)

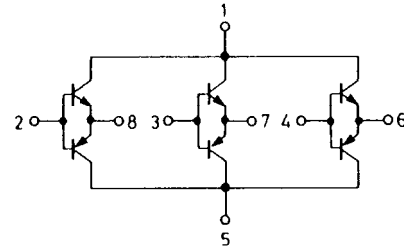

8-BT-108GK (FL tube)

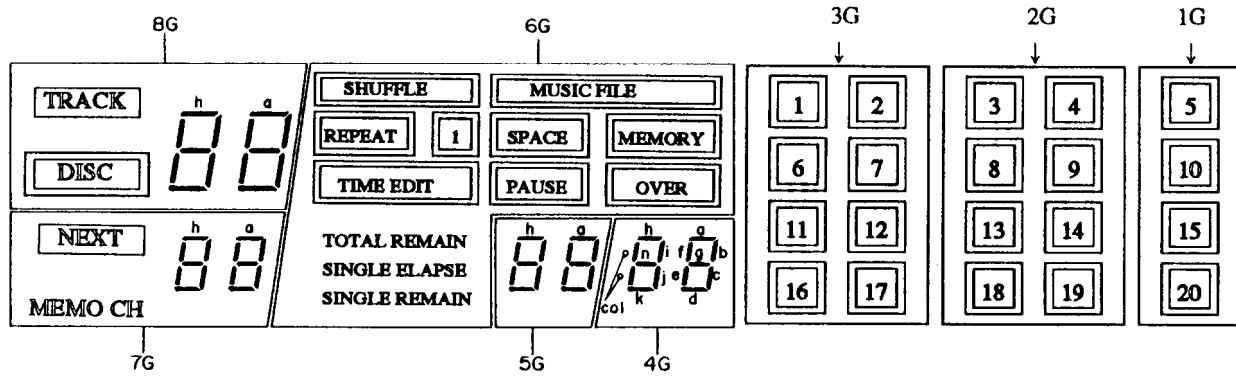

Pin No.	1	2	3	4	5	6	7	8	9	10	11	12	13	14	15	16	17	18	19	20
Connection	F1	F1	NP	8G	7G	6G	5G	4G	3G	2G	1G	NC	P16	P8	P9	NP	NP	NP	NP	NP
Pin No.	21	22	23	24	25	26	27	28	29	30	31	32	33	34	35	36	37	38	39	
Connection	NP	NP	NP	P13	P14	P10	P12	P11	P15	P4	P5	P3	P7	P6	P2	P1	NP	F2	F2	

NOTE: F1,F2---Filament, NP---No pin, NC---No connection, 1G-8G---Grid, P1-P16---Segment

	8G	7G	6G	5G	4G	3G	2G	1G
P1	a	a	REPEAT	a	a	1	3	5
P2	b	b	TIME EDIT	b	b	<input type="checkbox"/> <1>	<input type="checkbox"/> <3>	<input type="checkbox"/> <5>
P3	c	c		c	c	6	8	10
P4	d	d		d	d	7	9	
P5	e	e	1	e	e	<input type="checkbox"/> <6>	<input type="checkbox"/> <8>	<input type="checkbox"/> <10>
P6	f	f	MUSIC FILE	f	f	2	4	
P7	g	g	SPACER	g	g	<input type="checkbox"/> <2>	<input type="checkbox"/> <4>	
P8	h	h	PAUSE	h	h	<input type="checkbox"/> <7>	<input type="checkbox"/> <9>	
P9	i	i	MEMORY	i	i	11	13	15
P10	j	j	SHUFFLE	j	j	<input type="checkbox"/> <12>	<input type="checkbox"/> <14>	
P11	k	k	OVER	k	k	<input type="checkbox"/> <16>	<input type="checkbox"/> <18>	<input type="checkbox"/> <20>
P12	l	l	SINGLE REMAIN	l	l	16	18	20
P13	m	m	SINGLE ELAPSE	m	m	<input type="checkbox"/> <11>	<input type="checkbox"/> <13>	<input type="checkbox"/> <15>
P14	n	n		n	n	12	14	
P15	TRACK	NEXT	TOTAL REMAIN		:	17	19	
P16	DISC	MEMO CH				<input type="checkbox"/> <17>	<input type="checkbox"/> <19>	

ADJUSTMENT PROCEDURES

Instruments required

Dual trace oscilloscope, Frequency counter, AF oscillator, Test disc (SONY YEDS-18), AC voltmeter, Jitter meter, and Socket P4(Part no. 25050138)

1. Focus offset adjustment

Load the test disc YEDS-18 on the tray and play the track 2.

Connect the oscilloscope or jitter meter to terminal P106-1.
(Oscilloscope)

Adjust R109 until a clear trace of waveform pattern as shown photo 1 appear on the oscilloscope.

When the amount of jitter is broad, set R110 to mechanical center.

(Jitter meter)

Adjust R109 until the jitter meter reading becomes minimum.(Less than 10ns.)

After adjustment, disconnect the oscilloscope or jitter meter.

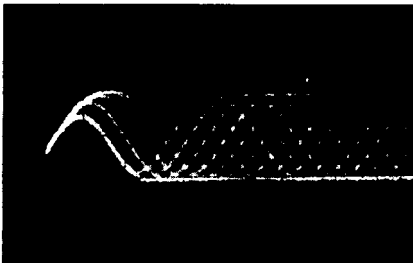
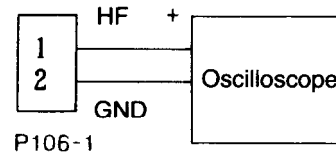
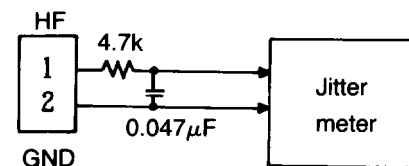

Photo 1



Oscilloscope range
Vertical : 0.5V/div.
Horizontal : 0.2 μ s/div.
DC, Ground: Center



2. Tracking offset adjustment

Load the test disc YEDS-18 on the tray and play the track 2.

Turn R116 to minimum position.(Counter clockwise)

Connect the oscilloscope between pin 3 (TR) of P107 and pin 2 (GND) of P106.

Adjust R108 until the center of tracking error signal on the oscilloscope becomes GND level.

Turn R132 to the mechanical center.

After adjustment, disconnect the oscilloscope.

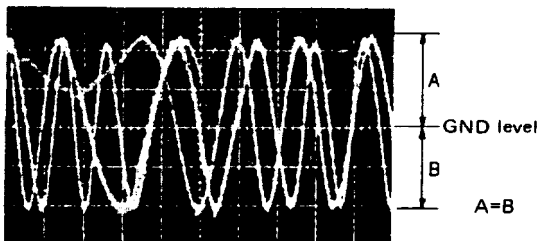
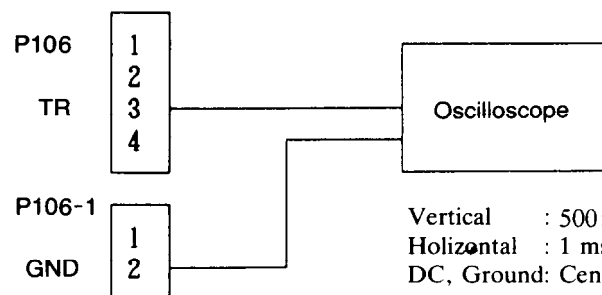

Photo 2



Vertical : 500mV/div.
Horizontal : 1 ms/div.
DC, Ground: Center

3. Focus gain adjustment

Set the output of AF oscillator to 800Hz, 1~1.5Vp-p.

Play the track 2 of test disc.

Connect the oscilloscope and the AF oscillator as shown below.

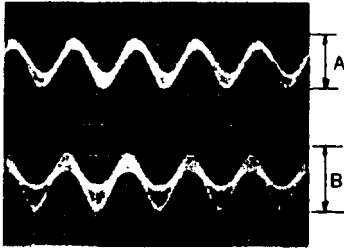
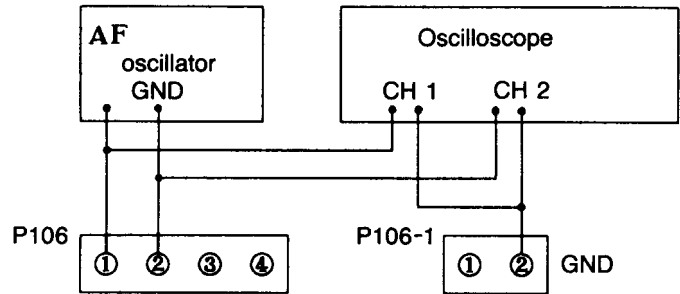

Photo 3



Vertical : 0.2V/div.
Horizontal: 0.5 ms/div.

Adjust R117 until 800Hz components of channels 1 and 2 on oscilloscope become same level.

After adjustment, disconnect the AF oscillator and the oscilloscope.

4. Tracking gain adjustment

Set the output of AF oscillator to 1.2kHz, 1~1.5Vp-p.

Play the track 2 of test disc.

Connect the oscilloscope and the AF oscillator as shown below.

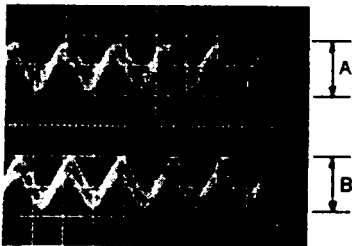
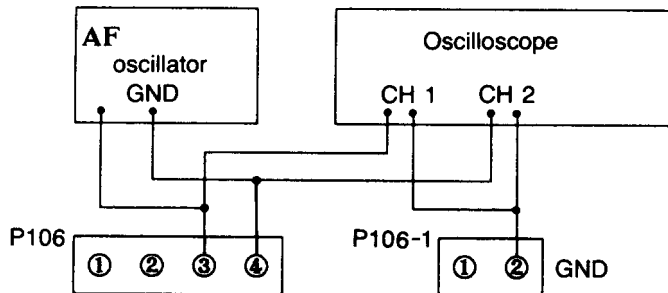

Photo 4



Vertical : 0.2V/div.
Horizontal: 0.5 ms/div.

Adjust R116 until 1.2kHz components of channels 1 and 2 on oscilloscope become same level.

After adjustment, disconnect the AF oscillator and the oscilloscope.

After adjustment, confirm that the center of tracking error signal becomes GND level.

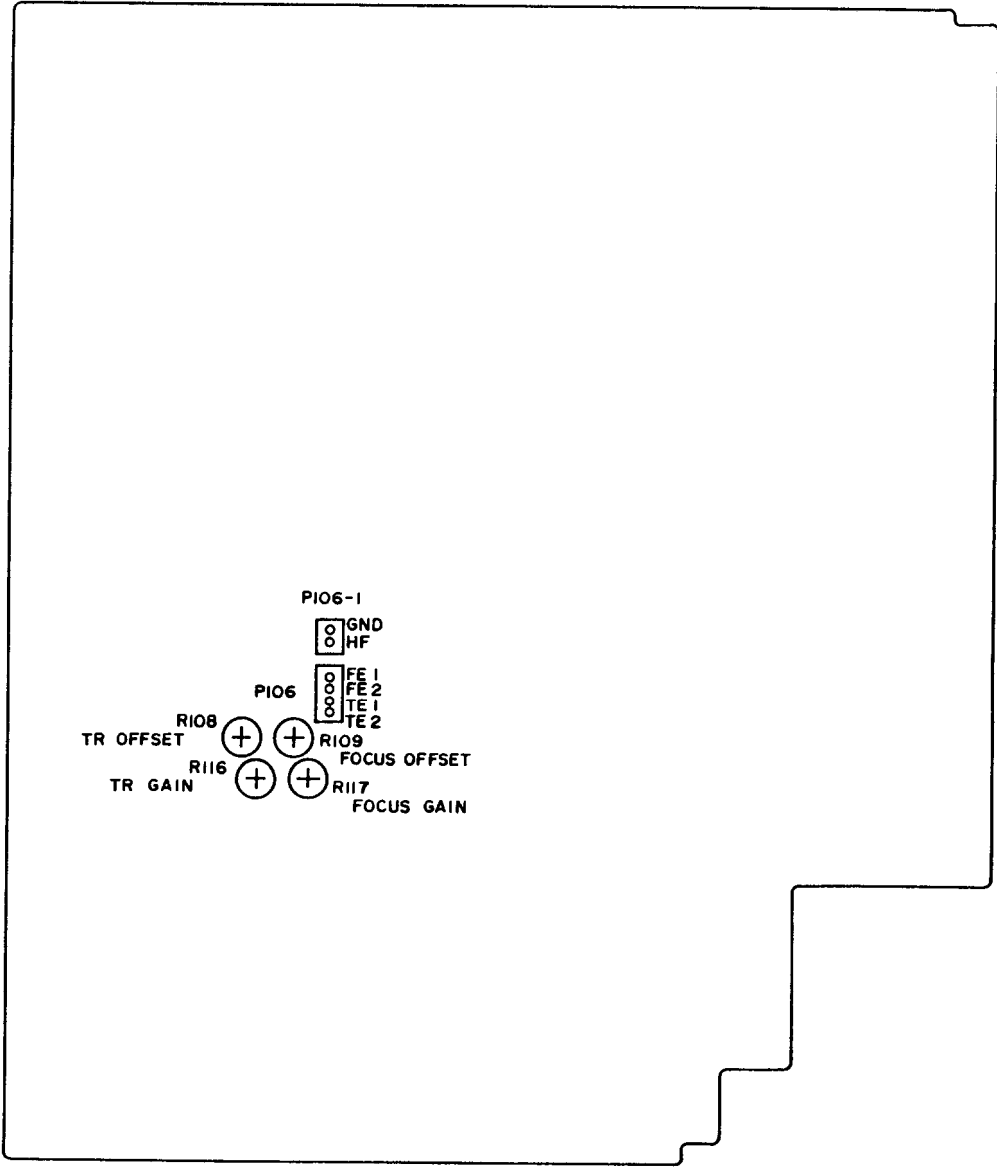

PARTS LIST

MAIN CIRCUIT PC BOARD (NAAR-4078-1/1A)

CIRCUIT NO.	PART NO.	DESCRIPTION
	ICs	
Q101	22240404Y	CXA1571S
Q104	22240366	CXA1372S
Q106	22240034	LA6510
Q107	222736	NJM4558S
Q108	22240365	CXD2500Q
Q109	22240405	CXP50112-197Q
Q112	22240018	M51943A
Q300	22240403	MN6472
Q301,Q302	222758	NJM072D
Q303,Q304	222902	NJM5532D-D
Q901,Q906	222780055MIT	M5F78M05L
Q902	222790053	79L05
Q903	222780155MIT	M5F78M15L
Q904	222790155MIT	M5F79M15L
	Photo coupler	
Q119	24120031	TOTX178
	Transistors	
Q102,Q905	2211503 or 2211504	2SA950-O or 2SA950-Y
Q103	221281	DTC114YS
Q105	22240168	STA341M-L
Q113,Q115	221281	DTC114YS
Q114	2211455	2SA1015-GR
Q116,Q117	2213090	DAT114YS
Q307,Q308	2212524	2SK363-GR
Q309,Q310	2211705 or 2211706	2SD655-E or 2SD655-F
	IC protectors	
QF101,QF102	252112	△ ICP-N15 <P>
	Diodes	
D101-D104	223163	1SS133
D105	224450562	MTZ5.6B
D106	223163	1SS133
D108,D109	223163	1SS133
D901-D904	22380029	HER102
D905-D908	22380045	RL203
D909	223163	1SS133
D910	224452202	MTZ22B
D911	224450512	MTZ5.1B
D912-D915	223163	1SS133
	X'tal	
X101	3010173	33.8688MHz
	Coil	
L101	231023	NCH-1062
	Filter	
L102	3030001	DSS306-55B 470M

Note:<P>:Except 120V model

PRINTED CIRCUIT BOARD VIEW FROM BOTTOM SIDE

1

2

3

4

5

5

CIRCUIT NO.	PART NO.	DESCRIPTION	CIRCUIT NO.	PART NO.	DESCRIPTION
	Capacitors			Capacitors	
C101,C105	354721019	100 μ F,6.3V,Elect.	C163,C165	354721019	100 μ F,6.3V,Elect.
C103,C137	374724724	4700pF \pm 5%,50V,TF	C167	354762209	22 μ F,35V,Elect.
C106,C109	354721019	100 μ F,6.3V,Elect.	C169	354721019	100 μ F,6.3V,Elect.
C110	374722234	0.022 μ F \pm 5%,50V,TF	C173	354744709	47 μ F,16V,Elect.
C111	374721044	0.1 μ F \pm 5%,50V,TF	C301-C304	373301514	150pF \pm 5%,125V,PP
C112,C141	374724734	0.047 μ F \pm 5%,50V,TF	C305,C306	373303314	330pF \pm 5%,125V,PP
C113,C124	374721034	0.01 μ F \pm 5%,50V,TF	C307-C310	373301014	100pF \pm 5%,125V,PP
C114-C116	374721044	0.1 μ F \pm 5%,50V,TF	C311,C312	374722734	0.027 μ F \pm 5%,50V,TF
C118,C144	354780479	4.7 μ F,50V,Elect.	C313,C314	374728214	820pF \pm 5%,50V,TF
C119,C122	374721044	0.1 μ F \pm 5%,50V,TF	C315,C316	373301814	180pF \pm 5%,125V,PP
C120,C125	354721019	100 μ F,6.3V,Elect.	C317,C318	374723924	3900pF \pm 5%,50V,TF
C127	354780109	1 μ F,50V,Elect.	C321,C322	373301014	100pF \pm 5%,125V,PP
C128,C133	354744709	47 μ F,16V,Elect.	C323,C324	354782219	220 μ F,50V,Elect.
C129,C153	374721044	0.1 μ F \pm 5%,50V,TF	C333,C334	374722224	2200pF \pm 5%,50V,TF
C130,C135	354721019	100 μ F,6.3V,Elect.	C335,C336	372122214	220pF \pm 5%,50V,Styrene
C131,C136	374721034	0.01 μ F \pm 5%,50V,TF	C339,C341	354724719	470 μ F,6.3V,Elect.
C132	354784799	0.47 μ F,50V,Elect.	C346,C348	354782219	220 μ F,50V,Elect.
C134	374723334	0.033 μ F \pm 5%,50V,TF	C349,C351	354782219	220 μ F,50V,Elect.
C138,C175	374722224	2200pF \pm 5%,50V,TF	C350	354742219	220 μ F,16V,Elect.
C139,C143	354721019	100 μ F,6.3V,Elect.	C352-C354	354742219	220 μ F,16V,Elect.
C140	374721524	1500pF \pm 5%,50V,TF	C355,C356	374721044	0.1 μ F \pm 5%,50V,TF
C145	354724719	470 μ F,6.3V,Elect.	C903,C904	393163327	3300 μ F,35V,Elect.
C146	354782299	0.22 μ F,50V,Elect.	C905,C906	354742229	2200 μ F,16V,Elect.
C147,C150	374721034	0.01 μ F \pm 5%,50V,TF	C907,C918	354764709	47 μ F,35V,Elect.
C148,C149	354721019	100 μ F,6.3V,Elect.	C908	354780229	2.2 μ F,50V,Elect.
C152,C154	354744709	47 μ F,16V,Elect.	C909,C910	354784719	470 μ F,50V,Elect.
C157,C159	354722219	220 μ F,6.3V,Elect.	C911,C912	354784709	47 μ F,50V,Elect.
C161	354722219	220 μ F,6.3V,Elect.	C915	354721029	1000 μ F,6.3V,Elect.

CIRCUIT NO.	PART NO.	DESCRIPTION
	Capacitors	
C917	354762219	220 μ F,35V,Elect.
C919	354764719	470 μ F,35V,Elect.
C920	354762209	22 μ F,35V,Elect.
	Resistors	
R106	5210066	N06HR22KBD,Semi-fixed
R109	5210060	N06HR2.2KBD,Semi-fixed
R116,R117	5210066	N06HR22KBD,Semi-fixed
R145	49163472407	RM1/101J 4.7K \times 7,Network
R146	49121472407	RM1/8GJ 4.7K \times 7,Network
	Plugs	
P101	25055152	NPLG-8P136
P102	25055153	NPLG-9P137
P103	25055148	NPLG-4P132
P104	25055149	NPLG-5P133
P106	25055045	NPLG-4P33
P106-1	25055038	NPLG-2P29
	Jack	
P105	25045172	HSJ1003-01-020
	Terminal	
P301	25045259	NPJ-2PDBL128,Output
	Socket	
SC101	2009990067	NSAS-2P0103
	Holder	
	27190751	

NOTE: THE COMPONENTS IDENTIFIED BY MARK Δ ARE CRITICAL FOR RISK OF FIRE AND ELECTRIC SHOCK. REPLACE ONLY WITH PART NUMBER SPECIFIED.

DISPLAY CIRCUIT PC BOARD(NADIS-4079-1)

CIRCUIT NO.	PART NO.	DESCRIPTION
	Remote control sensor	
U701	24130003	GP1U50XS
	Capacitor	
C701	353721019	100MF,6.3V,Elect.
	Push switches	
S701-S711	25035548	NPS-111-S510
S713-S715	25035548	NPS-111-S510
S718-S727	25035548	NPS-111-S510
	FL tube	
Q701	<u>212092</u>	8-BT-108GK <i>cc025</i>
	Holder	
	27190754Y	FL

HEADPHONE AMPLIFIER PC BOARD (NAAF-4080-1)

CIRCUIT NO.	PART NO.	DESCRIPTION
Q401	222654	NJM4556D,IC
C401,C402	354744709	47MF,16V,Elect. capacitors
R401	5142005AY	N16RGM20KB30F, Variable resistor
P401	25045164	HLJ4317-01-3020, Headphone jack

POWER SUPPLY PC BOARD(NAPS-4081-1)

CIRCUIT NO.	PART NO.	DESCRIPTION
C951	3500065A	Δ DE7150FZ103PAC400V/ 125V,IS capacitor
S951	25035558	Δ NPS-111-S520P, Power switch

BLOCK DIAGRAM

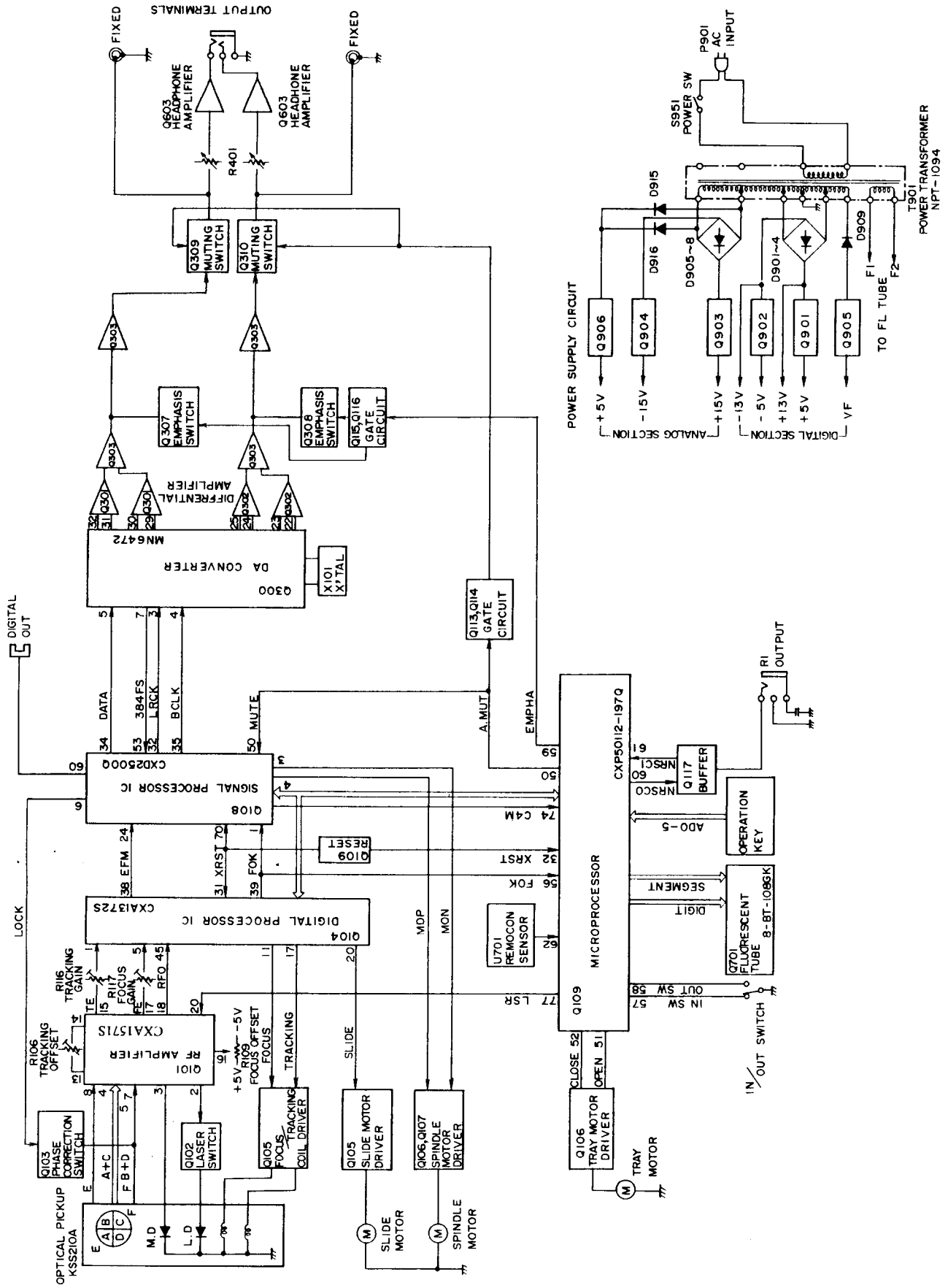

PACKING VIEW

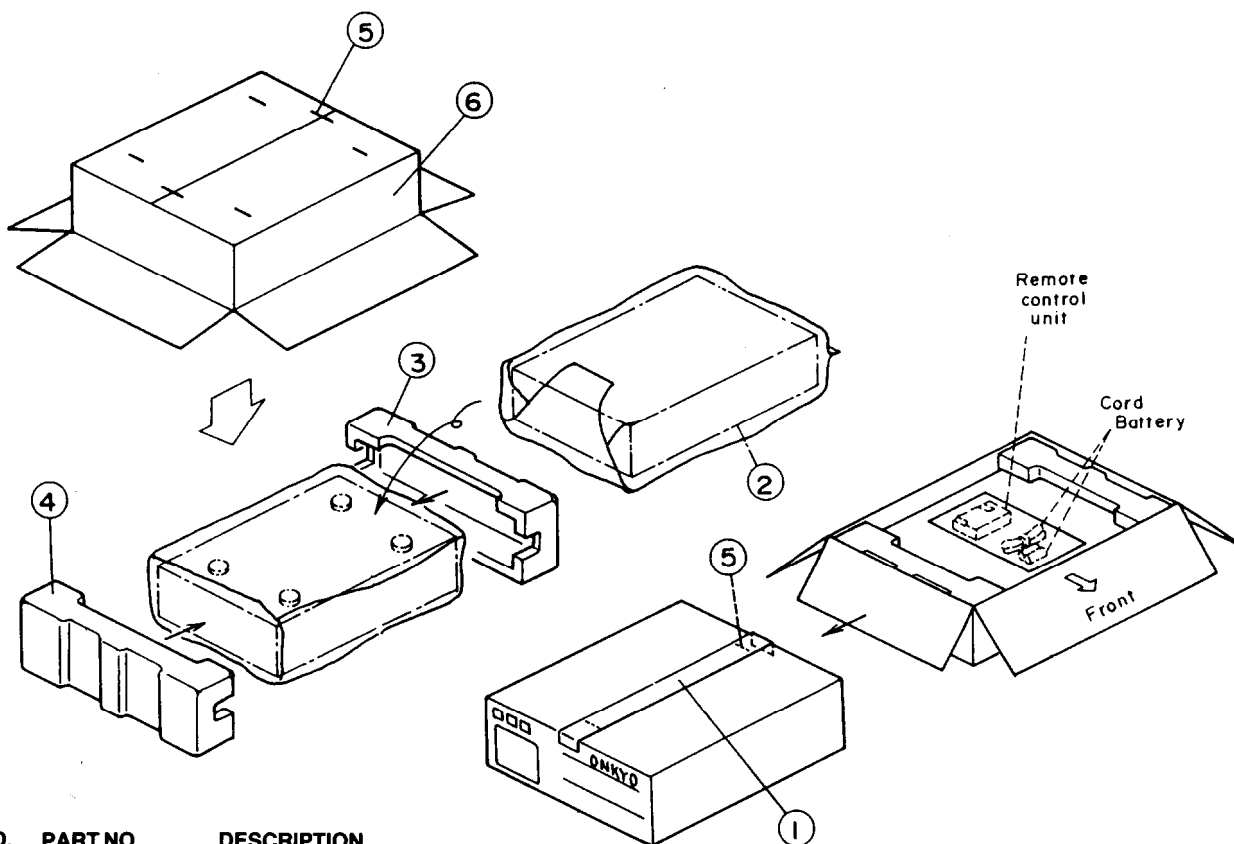

REF NO.	PART NO.	DESCRIPTION
1	260012	50×60cm,Damplon tape
2	29100037A	500×650mm,Styrene bag
3	29091434Y	Pad R
4	29091433Y	Pad L
5	282301	Sealing hook
6	29052120Y	Master carton box <Black>
	29052200Y	Master carton box <Silver>
		Accessory bag ass'y
	2010098A	Connection cable
	2010200	Connection cable for remote control
	24140196Y	RC-196C,Remote control transmitter
	3010054	UM-3,Two batteries
	29341572Y	Instruction manual <D>
	29341573Y	Instruction manual <C/P/W>
	29100097	350×250mm,Styrene bag
	29365019A	Warranty card <N>
	29365024	Warranty card <F>
	29100107	Styrene bag for warranty card <F>
	29358002J	Service station list <N>

NOTE:<D>:120V model
 <P>:230V and 240V models
 <W>:Worldwide model
 <N>:U.S.A. model
 <F>:French model
 <C>:Canadian model

ONKYO CORPORATION

International Division

Onariomon Yusen Bldg.,23-5,Nishi-Shinbashi
 3-chome,Minato-ku,TOKYO 105,JAPAN
 Tel:03-3432-6987 Fax:03-3436-6979

ONKYO U.S.A CORPORATION

200 Williams Drive,Ramsey,N.J. 07446,U.S.A.
 Tel:201-825-7950 Fax:201-825-8150

ONKYO DEUTSCHLAND GMBH ELECTRONICS

Industriestrasse 20,8034 Germering, GERMANY
 Tel:089 84 93 20 Fax:089 84 93 226

ONKYO FRANCE S.A.R.L.

Immeuble Le DIAMANT,Domaine Technologique De
 Saclay,4 rue Rene Razel,91892 SACLAY,FRANCE
 Tel:(1)69 41 35 10 Fax:(1)69 41 35 84

ONKYO Europe GmbH

Hellersbergstrasse 4,4040 Neuss,GERMANY
 Tel:02101 12 00 75 Fax:02101 10 33 06