

ONKYO® SERVICE MANUAL

COMPACT DISC PLAYER

MODEL DX-705**MODEL DX-703****Black and Silver models**

BHMD,BHMDN,BHMDC	120V AC, 60Hz
BHIMP,BHMPF,MP,MPF	230V AC, 50Hz
BHMW	120/220V AC, 50/60Hz
BHMQA	240V AC,50Hz

SAFETY-RELATED COMPONENT WARNING!!

COMPONENTS IDENTIFIED BY MARK \triangle ON THE SCHEMATIC DIAGRAM AND IN THE PARTS LIST ARE CRITICAL FOR RISK OF FIRE AND ELECTRIC SHOCK. REPLACE THESE COMPONENTS WITH ONKYO PARTS WHOSE PART NUMBERS APPEAR AS SHOWN IN THIS MANUAL.

MAKE LEAKAGE-CURRENT OR RESISTANCE MEASUREMENTS TO DETERMINE THAT EXPOSED PARTS ARE ACCEPTABLY INSULATED FROM THE SUPPLY CIRCUIT BEFORE RETURNING THE APPLIANCE TO THE CUSTOMER.

SPECIFICATIONS

Signal readout system:	Optical non-contact
Reading rotation:	About 500~200 r.p.m. (constant linear velocity)
Linear velocity:	1.2~1.4m/s
Error correction system:	Cross interleave readsolomon code
D/A converter:	1 bit PWM/AccuPulse D/A converter
Sampling frequency:	352.8kHz (8 times oversampling)
Number of channels:	2 (Stereo)
Frequency response:	5Hz~20kHz
Total harmonic distortion:	0.004% (at 1kHz)
Dynamic range:	96dB
Signal to noise ratio:	100dB
Channel separation:	90dB (at 1kHz)
Wow and Flutter:	Below threshold of measurability
Power consumption:	12 watts
Output level:	2 volts r.m.s.
Dimensions (W×H×D):	455×110×306mm 18"×4-3/8"×12"
Weight:	5.0kg, 11.0 lbs.

Specifications are subject to change without notice.



TABLE OF CONTENTS

Specifications.....	1
Service procedures.....	2
Note on compact disc.....	2
Caution on replacement of optical pickup.....	3
Protection of eyes from laser beam during servicing.....	4
Laser warning label.....	4
IC block diagrams and descriptions.....	5
Packing view.....	13
Chassis exploded view.....	14
Parts list DX-703.....	15
DX-705.....	16
Mechanism exploded view.....	17
Mechanism-parts list.....	18
Removal of disc tray.....	18
Adjustment procedures.....	20
Printed circuit board view	
Main circuit/Headphone pcb.....	23
Display/Power supply/Terminal pcb.....	35
Schematic diagram DX-705.....	25
DX-703.....	27
Printed circuit board-parts list.....	29
Block diagram.....	31
Trouble shooting guide.....	33

NOTE ON COMPACT DISC

● Holding Compact Discs

Hold Compact Discs by the edges so that you do not touch the surface of disc. Remember that the side of the disc with the "rainbow" reflection is the side containing the audio information.

Do not attach tape or paper to the label side of the disc and always be careful not to leave fingerprints on the side that is played.

● Storing Compact Discs

Store Compact Discs in a location protected from direct sunlight, high heat and humidity and extremely high and low temperatures. Discs should never be left in the trunk or interior of an automobile in the sun since the temperature can become very high in such a closed environment.

Always store Compact Discs in the holders in which they were sold. Never leave a disc in the player's disc holder for a long period of time.

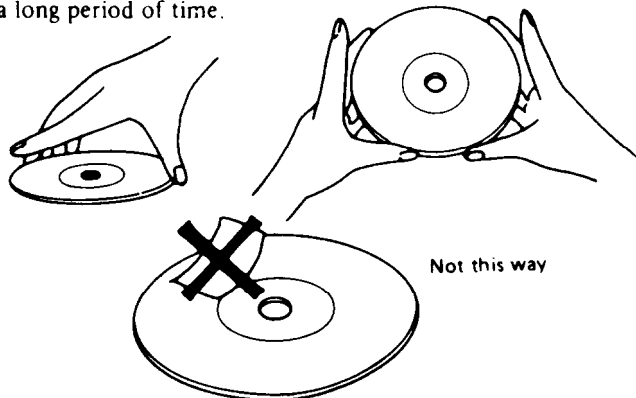

SERVICE PROCEDURES

1. Safety-check out

After correcting the original service problem, perform the following safety check before releasing the set to the customer:

Connect the insulating-resistance tester between the plug of power supply cord and chassis.

Specifications: More than 10Mohm at 500V.

2. Voltage Selector (Back panel)

Worldwide models are equipped with a voltage selector to conform with local power supplies. Be sure to set this switch to match the voltage of the power supply in user's area before turning the power switch on.

Voltage is changed by sliding the groove in the switch with a screw driver to the right or left.

Confirm that the switch has been moved all the way to the right or left before turning the power switch on.

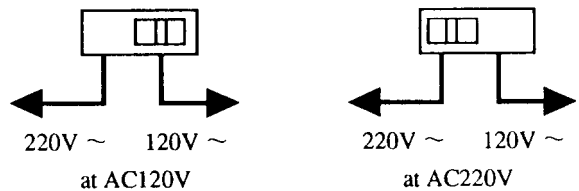

● Cleaning Compact Discs

Before playing a disc wipe off the playing surface with a soft cloth to remove dust and other soil. Wipe the surface in straight lines from the center of the disc outward, not in a circular motion as you would with a phonograph record.

Do not use benzene, chemical cleansers or phonograph record cleaning solutions to clean Compact Discs. Also avoid static electricity prevention solutions since they can damage the surface of Compact Discs.

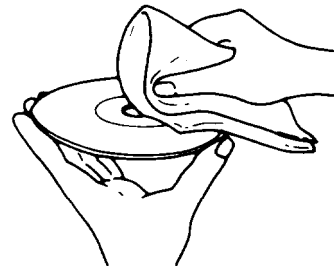

Problems Caused by Dew

Dew can form inside a Compact player when it is brought from a cold environment into a warm room, when a room is rapidly heated and if a player is left in a humid environment.

This dew can prevent the laser pickup from reading the data contained in the pits in the disc surface. If the player does not operate properly because of dew, remove the disc and leave the player's power switch on for about one hour to remove all moisture.

TROUBLESHOOTING GUIDE

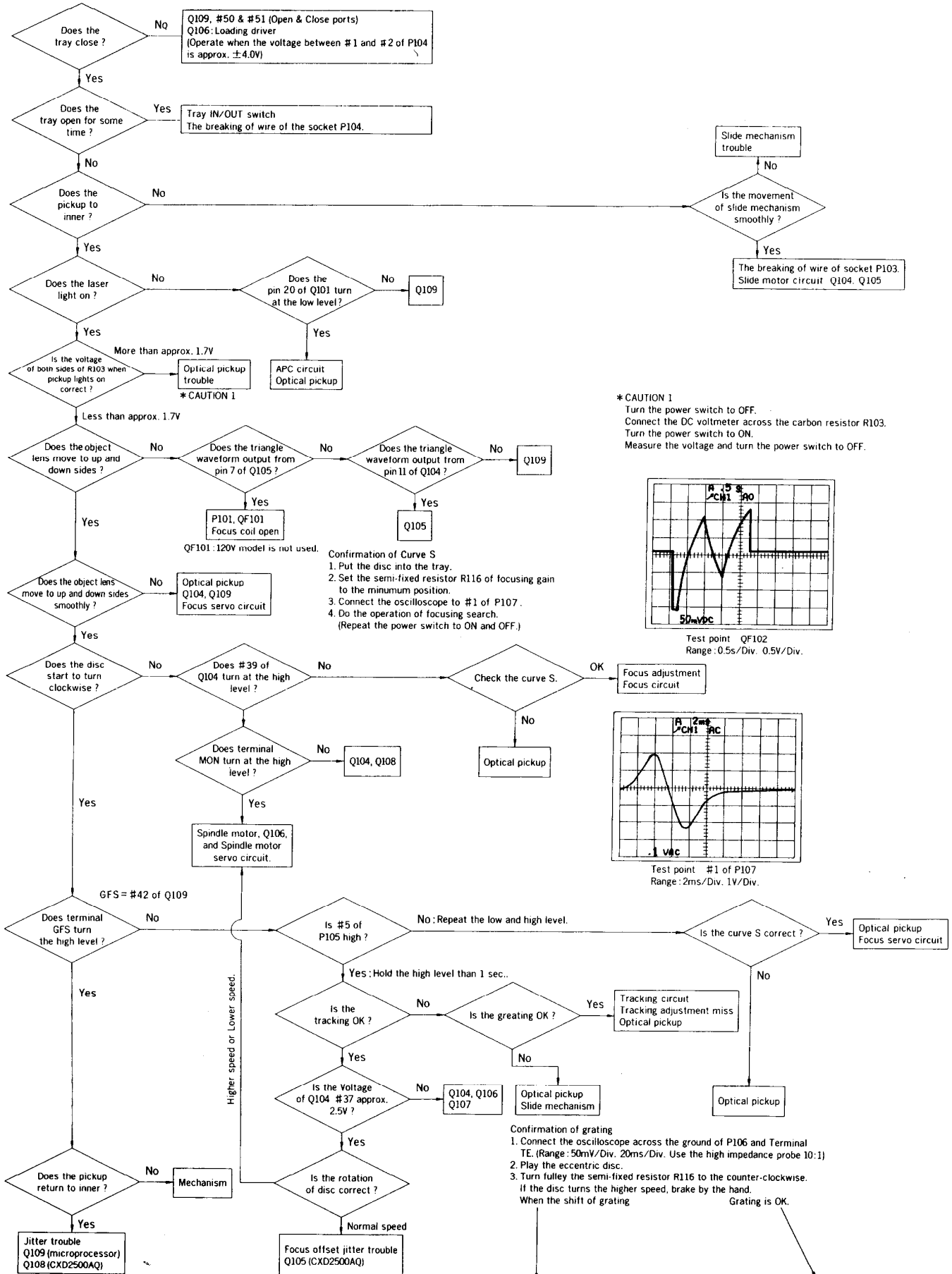

CAUTION ON REPLACEMENT OF OPTICAL PICKUP

The laser diode in the optical pickup block is so sensitive to static electricity, surge current and etc, that the components are liable to be broken down or its reliability remarkably deteriorated.

During repair, carefully take the following precautions. (The following precautions are included in the service parts.)

PRECAUTIONS

1. Ground for the work-desk.

Place a conductive sheet such as a sheet of copper (with impedance lower than $10M\Omega$) on the work-desk and place the set on the conductive sheet so that the chassis.

2. Grounding for the test equipment and tools.

Test equipments and toolings should be grounded in order that their ground level is the same the ground of the power source.

3. Grounding for the human body.

Be sure to put on a wrist-strap for grounding whose other end is grounded.

Be particularly careful when the workers wear synthetic fiber clothes, or air is dry.

4. Select a soldering iron that permits no leakage and have the tip of the iron well-grounded.

5. Do not check the laser diode terminals with the probe of a circuit tester or oscilloscope.

Care Should be taken with the optical pickup.

The optical pickup is sensitive to static electricity, surge currents, and other high electrical noise, and because there is the possibility of damage to performance, in the handling of the pickup, the utmost care must be taken, particularly with regard to static electricity.

1. When checking the laser terminal, avoid making connections using the probes of a tester or oscilloscope, or an ordinary power supply.
2. When replacing the optical pickup, first short the LD terminals and remove the connector. Also, when attaching the new optical pickup, after attaching the connector, unsolder the LD terminals.

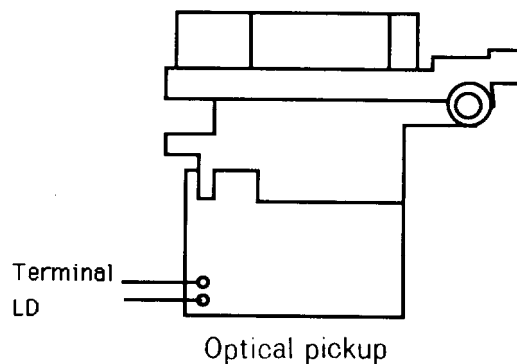

PROTECTION OF EYES FROM LASER BEAM DURING SERVICING

This set employs a laser. Therefore, be sure to follow carefully the instructions below when servicing.

WARNING!!

WHEN SERVICING, DO NOT APPROACH THE LASER EXIT WITH THE EYE TOO CLOSELY. IN CASE IT IS NECESSARY TO CONFIRM LASER BEAM EMISSION, BE SURE TO OBSERVE FROM A DISTANCE OF MORE THAN 30cm FROM THE SURFACE OF THE OBJECTIVE LENS ON THE OPTICAL PICK-UP BLOCK.

LASER WARNING LABELS

The label shown below are affixed.

1. Warning labels

These labels are located on the arm of mechanism and the back panel.

A

DANGER —INVISIBLE LASER RADIATION WHEN OPEN AND INTERLOCK FAILED OR DEFEATED. AVOID DIRECT EXPOSURE TO BEAM

CAUTION —HAZARDOUS LASER AND ELECTROMAGNETIC RADIATION WHEN OPEN AND INTERLOCK DEFEATED

ATTENTION —RAYONNEMENT LASER ET ELECTROMAGNETIQUE DANGEREUX SI OUVERT AVEC L'ECLenchement DE SECURITE ANNULE.

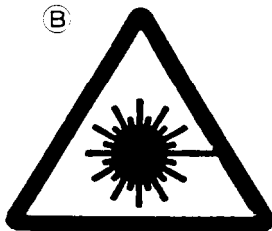

C

ADVARSEL: USYNLIG LASERSTRÅLING VED ÅBNING, NÅR SIKKERHEDSBRYDER ER UDE AF FUNKTION. UNDGÅ UDSÆTTELSE FOR STRÅLING.

D

VARO!
AVATTAESSA JA SUOJALUKITUS OHTETTAESSA OLET ALTIINA NÄKYMÄTTÖMÄLLE LASERSATEILYLLE. ÄLÄ KATSO SÄTEESEEN.

E

VARNING
OSYNLIG LASERSTRÅLNING NÅR DENNA DEL ÄR ÖPPNAD OCH SPÄRREN ÄR URKOPPLAD. BETRAKTA EJ STRÅLEN.

- A** : Danger label
- B** : Except 120V model
- C** : Except 120V model
- D, E** : Only 230V model

Laser Diode Properties

- Material: GaAS/GaAlAs
- Wavelength: 780nm
- Emission Duration: continuous
- Laser output: max. 0.5mW*

*This output is the value measured at a distance about 1.8mm from the objective lens surface on the Optical Pick-up Block.

2. Certification label (120V model)

This label is located on the back panel.

PRODUCT IS CERTIFIED BY THE MANUFACTURER TO COMPLY WITH DHHS RULES 21 CFR SUBCHAPTER J APPLICABLE AT THE DATE OF MANUFACTURE

MANUFACTURED

3. Class 1 label (Except 120V model)

This label is located on the back panel.



LUOKAN 1 LASERLAITE

KLASS 1 LASER APPARAT

ADVARSEL

Denna mækning er anbragt på apparatets højre side og indikerer, at apparatet arbejder med laserstråler af klasse 1, hvilket betyder, at der anvendes laserstråler af svageste klasse, og at man ikke på apparatets yderside kan blive udsat for utilsadelig kraftig stråling.

APPARATET BØ/R KUN ÅBNES AF FAGFOLK MED SÉ RLIGT KENDSKAB TIL APPARATER MED LASERSTRÅLER!

Indvendigt i apparatet er anbragt den her gengivne advarselsmærkning, som advarer imod at foretage sådanne indgreb i apparatet, at man kan komme til at udsætte sig for laserstråling.

VAROITUS! LAITTEEN KÄYTTÄMINEN MUULLA KUIN TASSA KÄYTTÖOHJEESSA MAINTULLA TAVALLA SAATTAA ALTISTAA KÄYTTÄJÄN TURVALLISUUSLUOKAN 1 YLITÄVÄLLE NÄKYMÄTTÖMÄLLE LASERSATEILYLLE.

IC BLOCK DIAGRAM AND DESCRIPTIONS

CXA1571S (RF Amp)

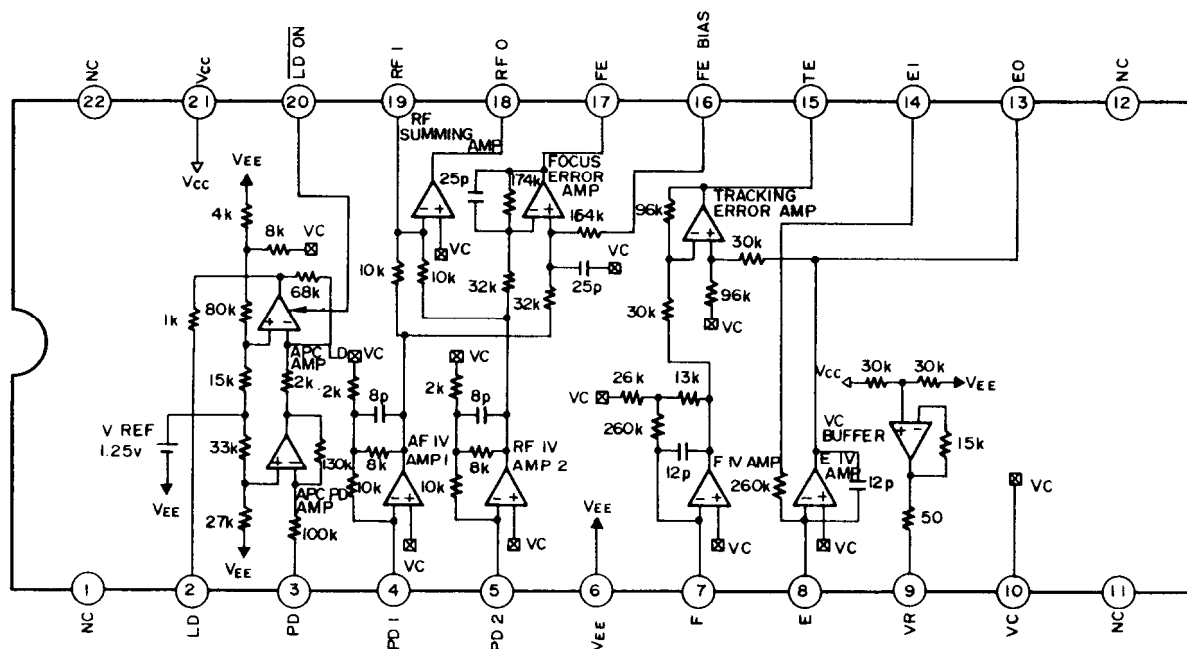

Pin No.	Symbol	I/O	Description
2	LD	O	Output terminal of APC amplifier.
3	PD	I	Input terminal of APC amplifier.
4	PD1	I	Inversion input terminal for RF I-V amplifier. Connect to photo diode A+C.
5	PD2	I	Inversion input terminal for RF I-V amplifier. Connect to photo diode B+D.
7	F-IN	I	Inversion input terminal for F I-V amplifier. Connect to photo diode F.
8	E-IN	I	Inversion input terminal for E I-V amplifier. Connect to photo diode E.
9	VR	O	DC voltage output of $(V_{CC} + V_{EE})/2$.
10	VC	I	Middle point voltage input terminal.
13	EO	O	Monitor output terminal for I-V amplifier E.
14	EI	-	Gain adjustment terminal for I-V amplifier E.
15	TE	O	Tracking error amplifier output terminal. The signal E-F is output from this terminal.
16	FE-BIAS	I	Bias adjustment terminal for non-inversion side of focus error amplifier.
17	FE	O	Focus error amplifier output terminal.
18	RFO	O	RF amplifier output terminal.
19	RFI	I	Inversion input terminal of RF amplifier.
20	LD-ON	I	Change-over terminal for APC amplifier.

CXA1372S (Servo Signal Processor)

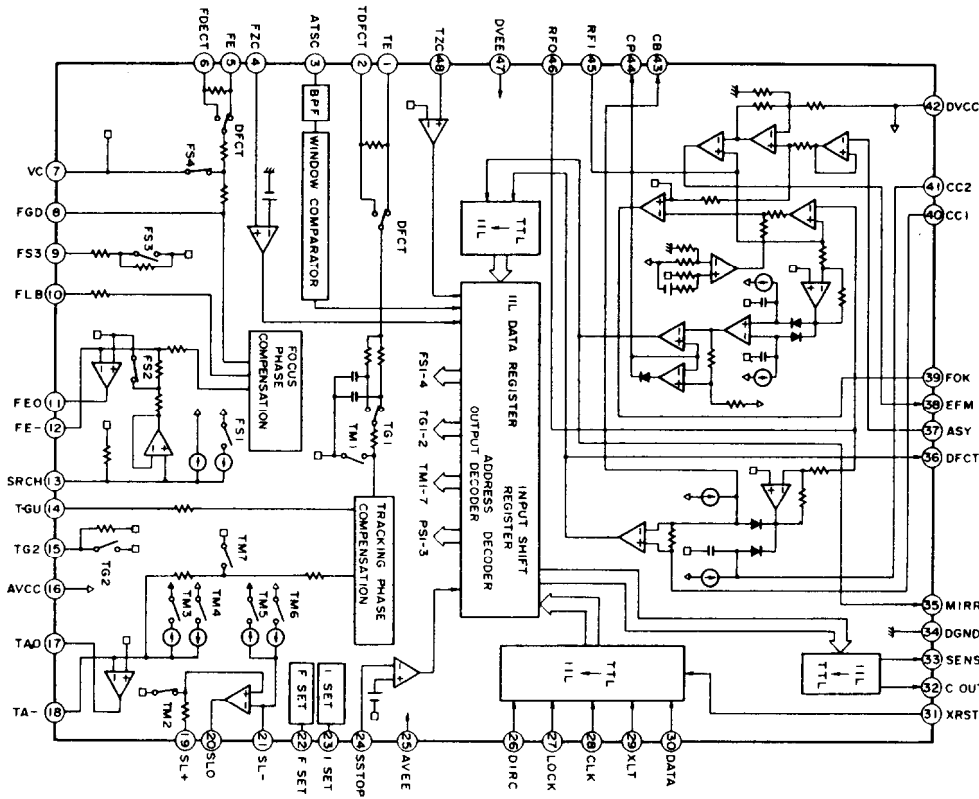

PIN. NO.	SYMBOL	I/O	DESCRIPTION	PIN. NO.	SYMBOL	I/O	DESCRIPTION
1	TE	I	Tracking error input terminal.	22	FSET	I	Peak setting input of phase correction of focus tracking.
2	TDFCT	I	Capacitor connection terminal for time constant when defect.	23	ISET	I	This terminal is flowed the current so that the focus search, tracking jump, and sled kick height is decided.
3	ATSC	I	Window comparator input terminal for ATSC detection.	24	SSTOP	I	Inner switch selection input terminal.
4	FZC	I	Focus zero-cross comparator input terminal.	26	DIRC	I	This terminal is used when a track jump.
5	FE	I	Focus error input terminal.	27	LOCK	I	The sled runaway prevention circuit operates at the low level.
6	DFDCT	I	Capacitor connection terminal for time constant when defect.	28	CLK	I	Serial data transfer clock input from microprocessor.
7	VC	I	Mid-point voltage input terminal.	29	XLT	I	Latch input from microprocessor.
8	FGD	I	Connect the capacitor between pin 9 and this pin when the high frequency gain of focus servo is dropped.	30	DATA	I	Serial data input from microprocessor.
9	FS3	I	Focus servo high frequency gain changeover input terminal.	31	XRST	I	Reset input terminal. Active low.
10	FLB	I	Input terminal for the low frequency boost of focus servo.	32	C. OUT	O	Signal output to count the track numbers.
11	FEO	O	Focus drive output terminal.	33	SENS	O	This terminal outputs FZC, and SSTOP to according command from microprocessor.
12	FE-	I	Inversion input terminal of focus amplifier.	35	MIRR	O	Mirror comparator output terminal.
13	SRCH	I	Time constant terminal to make the focus search waveform.	36	DFCT	O	Defect comparator output terminal.
14	TGU	I	Tracking high frequency gain changeover input terminal.	37	ASY	I	Auto asymmetry control input terminal.
15	TG2	I	Tracking high frequency changeover input terminal.	38	EFM	O	EFM comparator output terminal.
17	TAO	O	Tracking drive output terminal.	39	FOK	O	Focus OK comparator output terminal.
18	TA-	I	Inversion input terminal of tracking amplifier.	40	CC1	O	Defect bottom hold output terminal.
19	SL+	I	No-inversion input terminal of sled amplifier.	41	CC2	I	Defect bottom hold input terminal from CC1.
20	SLO	O	Sled (slide) drive output terminal.	43	CB	I	Defect bottom hold capacitor connection terminal.
21	SL-	I	Inversion input terminal of sled amplifier.	44	CP	I	Mirror hold capacitor connection terminal.
				45	RFI	I	RF summing amplifier input terminal.
				46	RFO	O	RF summing amplifier output terminal.
				48	TZC	I	Tracking zero-cross comparator input terminal.

YM3433(18 bits/8 times Oversampling Digital Filter)

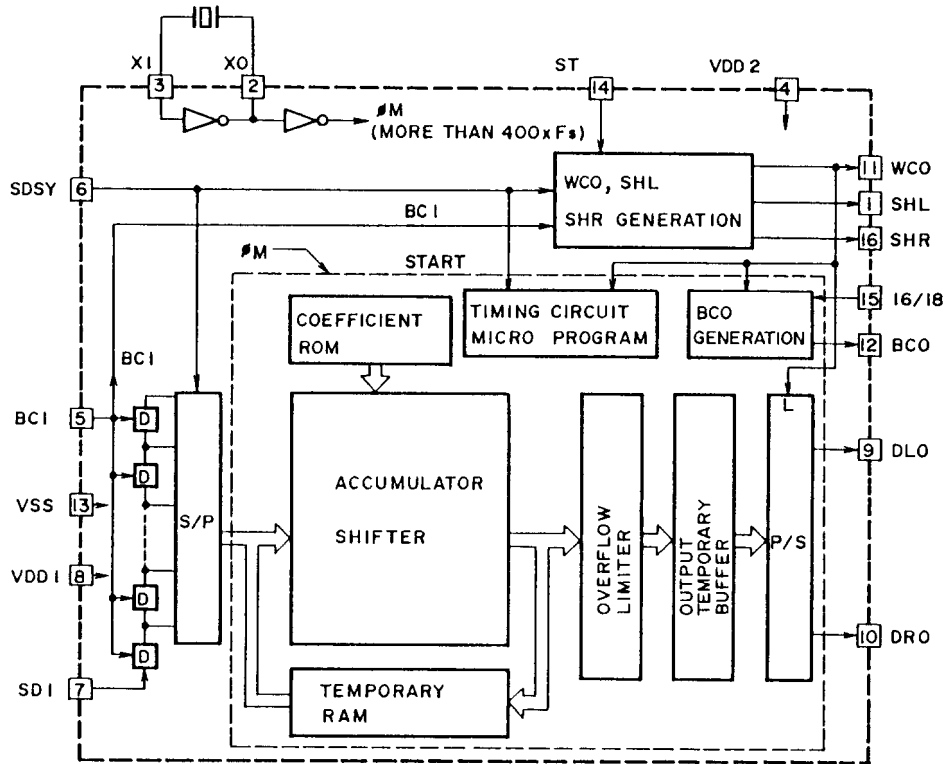

Pin No.	Terminal	Function
1	SHL	ST=L(1 DAC):L channel deglitch signal output. ST=H(2 DACs):L and R channels deglitch signal output. (Not used.)
2	XO	Connect the crystal oscillator for the system clock to these terminals.
3	XI	
4	VDD2	Power supply terminal for crystal oscillator and deglitch signal system.
5	BCI	Bit clock input terminal of input data.
6	SDSY	Clock input terminal to show the input timing and L/R channels partitioned of input data.
7	SDI	Data input terminal.
8	VDD1	Power supply terminal.(Connect to 5V.)
9	DLO	ST=L(1 DAC):L and R channels data output terminal. ST=H(2 DAC):L channel data output terminal.
10	DRO	R channel data output terminal.
11	WCO	Word clock output terminal for output data DLO/DRO.
12	BCO	Bit clock output terminal for output data DLO/DRO.
13	VSS	Ground terminal.
14	ST	1 DAC/2 DAC selection terminal.(1 DAC at low level and 2 DAC at high level.)
15	16/18	Bit number selection terminal.(16 bits at low level and 18 bits at high level.)
16	SHR	1 DAC(ST=L):R channel deglitch signal output.(Not used.)

CXD2500AQ (Digital Signal Processor)

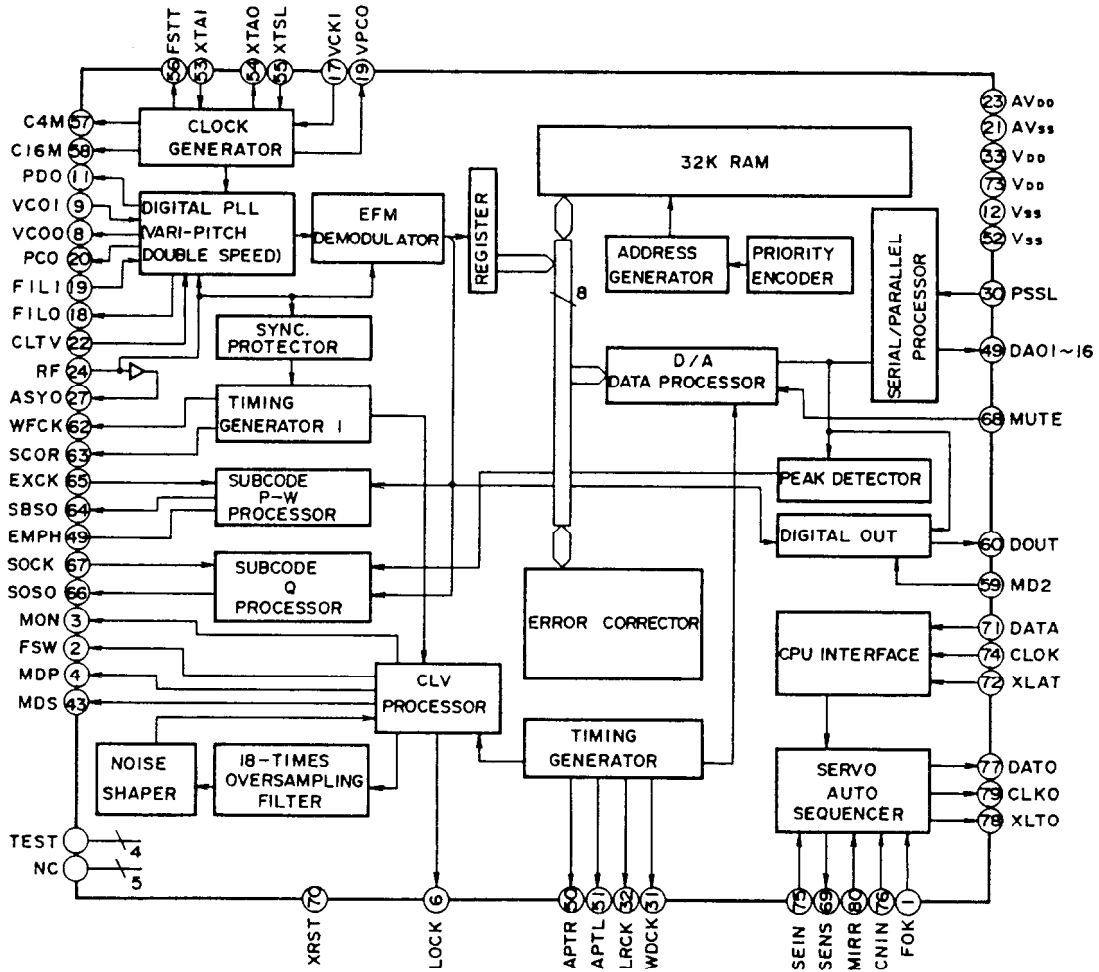

LB1639 (Volume Motor Drive)

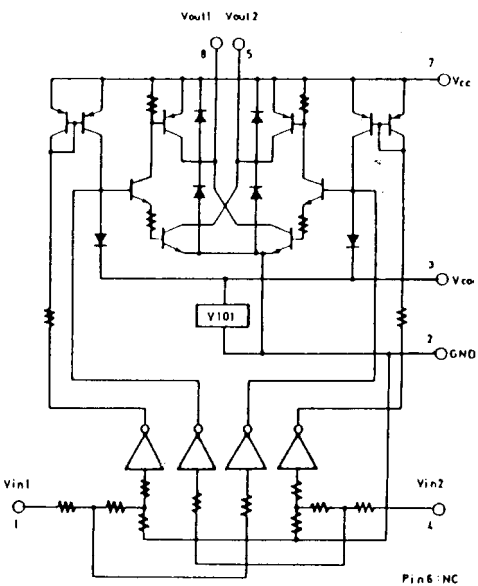

74HC164(8-bits Serial/Parallel Output Shift Register)

TRUTH TABLE

Inputs				Outputs			
Clear	Clock	A	B	QA	QB	QH
L	X	X	X	L	L	L
H	L	X	X	QA0	QB0	QH0
H	↑	H	H	H	QAn	QGn
H	↑	L	X	L	QAn	QGn
H	↑	X	L	L	QAn	QGn

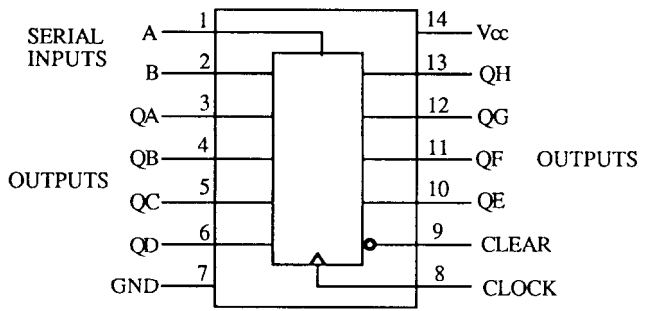

NO.	SYMBOL	I/O	DESCRIPTION	NO.	SYMBOL	I/O	DESCRIPTION
1	FOK	I	Focus OK input	42	DA08	O	GFS output
2	FSW	O	Output filter changeover output of spindle motor	43	DA07	O	RFCK output
3	MON	O	Spindle motor control output	44	DA06	O	C2P0 output
4	MDP	O	Spindle motor servo control	45	DA05	O	XRAOF output
5	MDS	O	Spindle motor servo control	46	DA04	O	MNT3 output
6	LOCK	O	H when GFS is high	47	DA03	O	MNT2 output
7	NC			48	DA02	O	MNT1 output
8	VCOO	O	Oscillation circuit output for analog FEM PLL	49	DA01	O	MNT0 output
9	VCOI	I	Oscillation circuit input for analog EFM PLL (8.6436MHz)	50	APTR	O	Control output for aperture correction. H when Rch.
10	TEST	I	Test terminal	51	APT1	O	Control output for aperture correction. H when L.ch.
11	PDO	O	Charge pump output for analog EFM PLL	52	Vss		Ground
12	Vss		Ground terminal	53	XTAI	I	Crystal oscillation circuit input of 16.9344MHz or 33.8688MHz input
13-15	NC			51	XTAO	O	Crystal oscillation circuit output of 16.9344MHz
16	VPCO	O	PLL charge pump output for variable pitch	55	XTSL	I	Crystal selection input terminal. L when 16.9344MHz. H when 33.8688MHz.
17	VCKI	I	Clock input for variable pitch from VCO (16.934MHz)	56	FSTT	O	2/3 divided output of pins 53 & 54
18	FILO	O	Filter output for master PLL	57	CIM	O	4.2336MHz output
19	FILI	I	Filter input for master PLL	58	CI6M	O	16.9344MHz output
20	PCO	O	Charge pump output for master PLL	59	MD2	I	Digital output control input. On at H & Off at L.
21	AVss		Analog ground	60	DOUT	O	Digital output
22	CLTV	I	VCO control voltage input for master	61	EMPH	O	Emphasis control output. Active H.
23	AVDD		Analog section power supply (+5V)	62	WFCK	O	Write frame clock output
24	RF	I	EFM signal input	63	SCOR	O	Sub-code detection output. H when is detected S0 or S1.
25	TEST2	I	Connect to the ground.	64	SBSO	O	Serial output of sub code (P~W)
26	TEST3	I	Connect to the ground.	65	EXCK	I	Clock input for read out SBSO
27	ASYO	O	EFM full swing output	66	SQSO	O	Sub Q 80 bits. PCM peak. and level data 16 bits output
28	TEST4	I	Connect to the ground.	67	SQCK	I	Clock input for read out SQSO
29	NC			68	MUTE	O	Muting control output. Active H.
30	PSSL	I	Audio data output mode changeover input. Serial data at L. and parallel data at H.	69	SENS	-	Sens output. Output to microprocessor
31	WDCK	O	D/A interface for 48 bits slot. Word clock f=2Fs.	70	XRST	I	System reset. Rest at low level.
32	LRCK	O	D/A interface for 48 bits slot. LR clock f=Fs.	70	DATA	I	Serial data input from microprocessor
33	VDD		Power supply terminal (+5V)	72	XLTA	I	Latch input from microprocessor. Latch the serial data at trailing.
34-49			Data output terminals	73	VDD		Power supply
			PSSL=1 PSSL=0	74	CLOCK	I	Serial data transfer clock input from microprocessor
34	DA16	O	DA16	75	SEIN	I	Sens input from SSP
35	DA15	O	DA15	76	CNCI	I	Track jump numbers count signal input
36	DA14	O	DA14	77	DATO	O	Serial data output to SSP
37	DA13	O	DA13	78	XLTO	O	Serial data latch output to SSP. Latch at trailing.
38	DA12	O	DA12	79	CLKO	O	Serial data transfer clock output to SSP
39	DA11	O	DA11	80	MIRR	I	Mirror signal input
40	DA10	O	DA10				
41	DA09	O	DA09				

Note:SSP:Q104 CXA1372S

LA6510 (Power OP Amp)

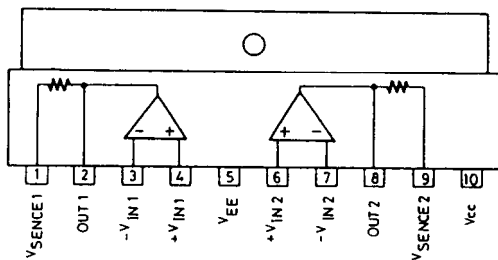

SM5861AP (D/A converter)

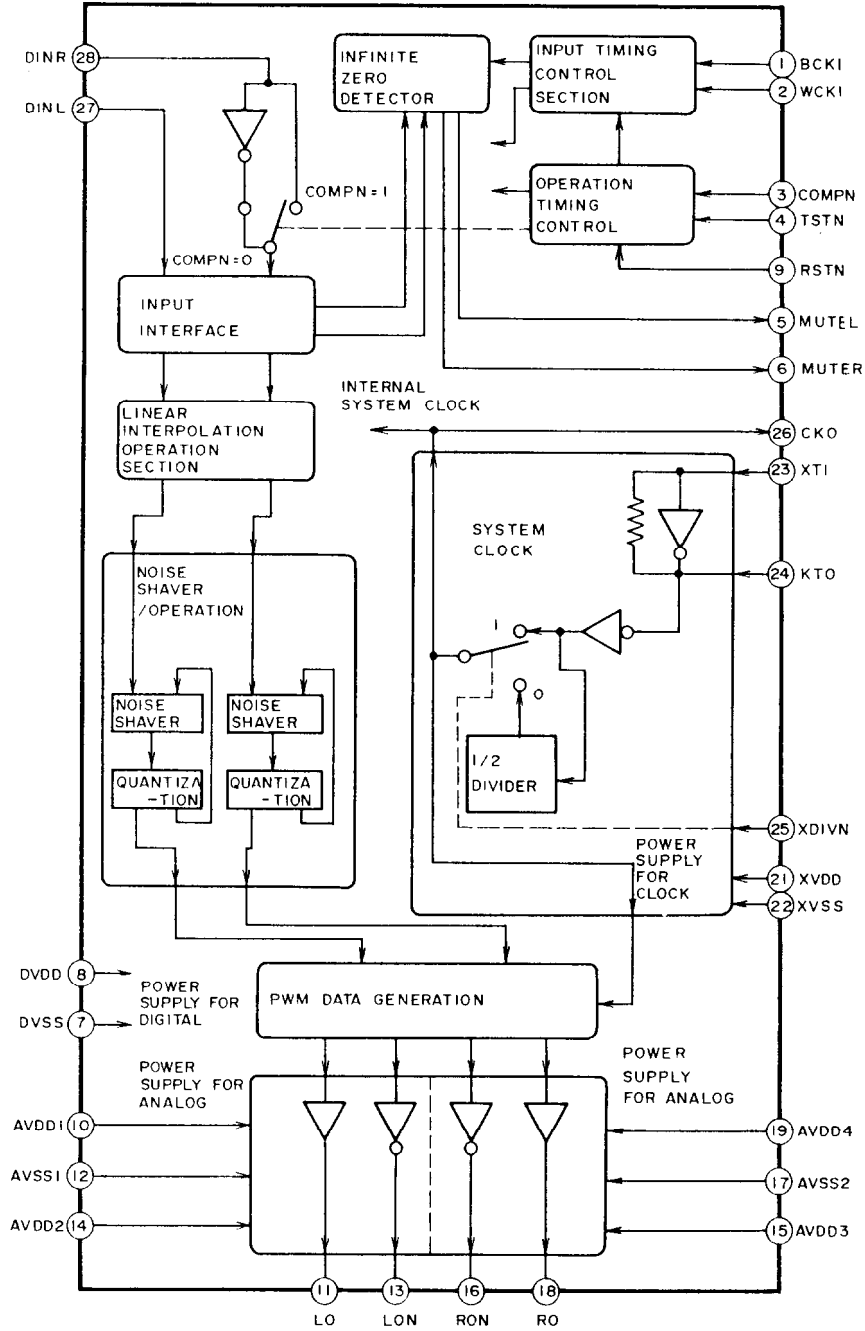

Pin No.	Symbol	Description	Pin No.	Symbol	Description
1	BCKI	Serial input data bit clock	15	AVDD3	5V supply for analogue section
2	WCKI	Input data word clock	16	RON	Data output
3	COMPN	Mode select of PWM output	17	AVSS2	Ground for analogue section
4	TSTN	Test terminal	18	RO	Data output
5	MUTEL	Muting output for left channel	19	AVDD4	Ground for analogue section
6	MUTER	Muting output for right channel	20	NC	
7	DVSS	Ground for digital section	21	XVDD	5V supply for clock section
8	DVDD	5V power supply for digital section	22	XVSS	Ground for clock section
9	RSTN	Reset input	23	XTI	Crystal oscillator input
10	AVDD1	5V supply for analogue section	24	XTO	Crystal oscillator output
11	LO	Data output	25	XDIVN	System clock select
12	AVSS1	Ground for analogue section	26	CKO	Clock output
13	LON	Data output	27	DINL	Serial data input for left channel
14	AVDD2	5V supply for analogue section	28	DINR	Serial data input for right channel

CXP50112 - 369Q (Microprocessor)

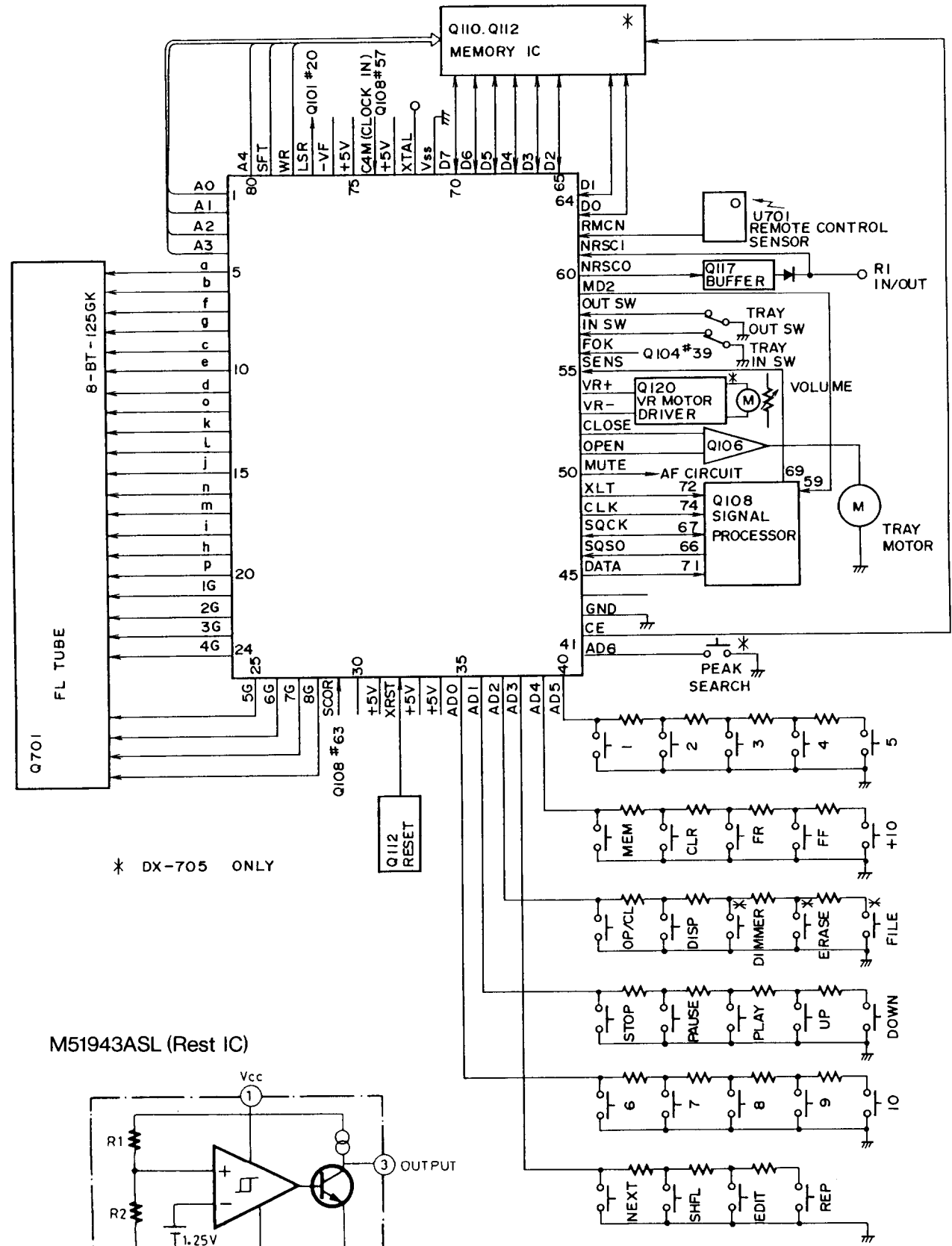

* DX-705 ONLY

M51943ASL (Rest IC)

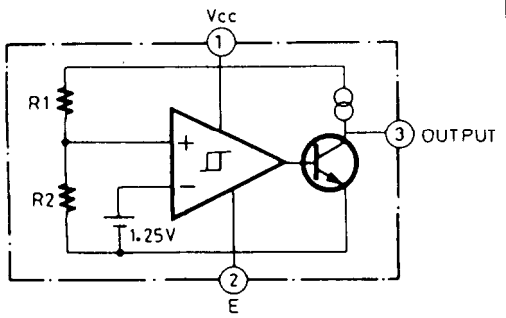

Pin No.	Symbol	Description
1~4	A0~A3	Music file address signal.
5~20	a~p	Fluorescent indicator tube segment drive output terminals.
21~28	1G~8G	Fluorescent indicator tube grid drive output terminals.
29	SCOR	Synchronizing signal detection input terminal of sub code frame.
31	5V	
32	XRST	Reset input terminal.Reset at the low level.
33,34	5V	
35~41	AD0~AD6	AD input terminal.Connect to the operation key.
42	CE	Chip enable terminal.
43	GND	
45	DATA	Serial data output terminal.
46	SQSO	Subcode Q input terminal.
47	SQCK	Subcode Q read clock input/output terminal.
48	CLK	Serial data transmission clock output terminal.
49	XLT	Command execution output terminal.
50	MUTE	Muting ON/OFF control output terminal.ON at the high level.
51	OPEN	Tray open control output terminal.Open at the low level.
52	CLOSE	Tray close control output terminal.Close at the low level.
53	VR-	Volume control output.
54	VR+	Volume control output.
55	SENS	Interface of signal processor and microprocessor ICs.
56	FOK	Focus OK input terminal.Focus OK at the high level.
57	INSW	Tray close detection input terminal.
58	OUTSW	Tray open detection input terminal.
59	MD2	Digital output control output.
60	NRSCO	Remote control signal (RI signal) output terminal.
61	NRSCI	Remote control signal (RI signal) input terminal.
62	RMCN	Remote control signal input terminal.
63~70	D0~D7	Music file data signal.
71	Vss	Ground terminal.
72	XTAL	Clock output terminal.
73	5V	
74	C4M	System clock input terminal.
75	5V	
76	VF	Negative power supply terminal for fluorescent indicator tube.
77	LSR	Optical pickup control output terminal.On at the low level.
78	WR	Music file read/write control signal.
79	SFT	Music file shift signal. Control the serial data at the rise pulse.
80	A4	Music file address signal.

PACKING VIEW

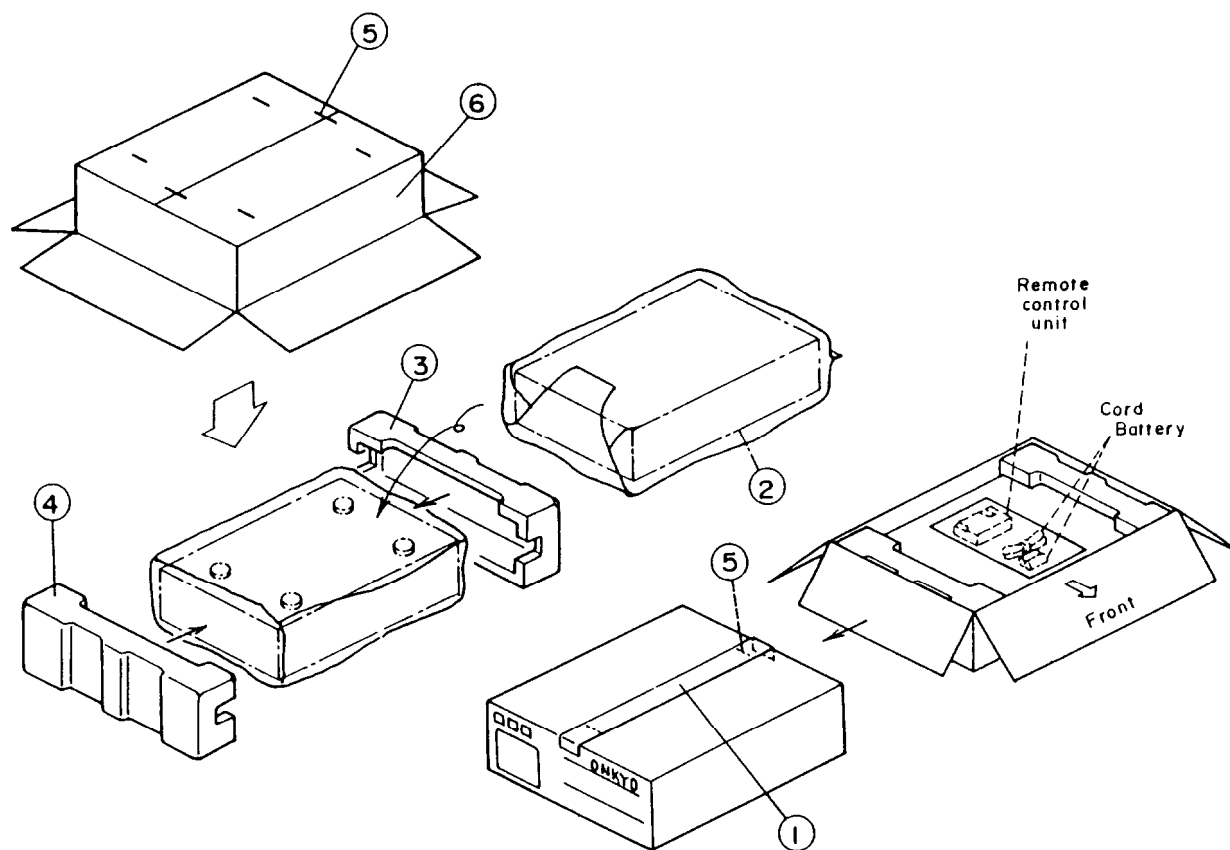

REF NO.	PART NO.	DESCRIPTION
1	29110071	Damplon tape
2	29100037A	500×650mm, Styrene bag
3	29091434Y	Pad R
4	29091433Y	Pad L
5	282301	Sealing hook
6	29052371Y	Master carton box <DX-703BH>
	29052390Y	Master carton box <DX-703S>
	29052374Y	Master carton box <DX-705BH>
	29052390Y	Master carton box <DX-705S>
	Accessory bag ass'y	
	2010098A	Connection cord
	2010200	Remote control cord
	24140196Y	RC-196C, Remote control transmitter <DX-703>
	24140221Y	RC-221C, Remote control transmitter <DX-705>
	29341705Y	Instruction manual <D>
	29341707Y	Instruction manual <C/P/W/Q>
	3010054	UM-3, Two batteries
	29100097	350×250, Styrene bag
	29365019A	Warranty card <N>
	29365024A	Warranty card <F>
	29358002J	Service station list <N>
	29100107	Styrene bag for warranty card <F>
	25055040	CV-K-2, Conversion plug <W>

NOTE: <BH>: Black model only
 <S>: Silver model only
 <D>: 120V model only
 <P>: 230V model only
 <W>: Worldwide model only
 <Q>: 240V model only
 <N>: U.S.A. model only
 <F>: French model only
 <C>: Canadian model only

CHASSIS-EXPLODED VIEW

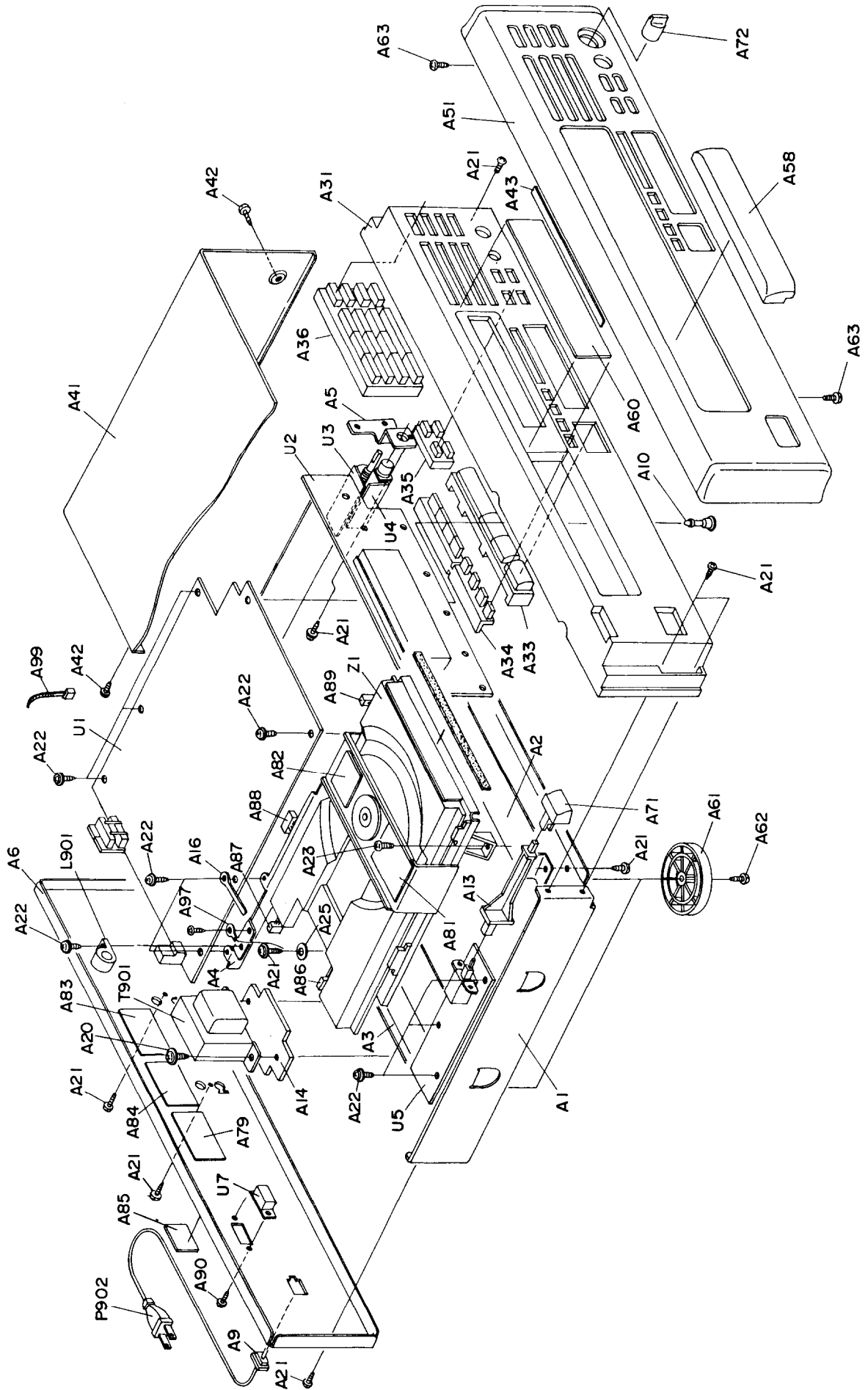

PARTS LIST

DX-703

REF. NO.	PART NO.	DESCRIPTION	REF. NO.	PART NO.	DESCRIPTION
A1	27100227BY	Chassis	A58	27211396Y	Tray panel
A2	27141520Y	Bracket F		27211398	Tray panel <S>
A3	27141521Y	Bracket R	A60	28191623AY	Clear plate
A4	27130642Y	Bracket C	A61	27175254Y	Leg
A5	27141522Y	Bracket HP	A62	834430088	3TTS+8B(BC),Self-tapping screw
A6	27121562Y	Back panel <D>	A63	833430080	3TTP+8P(BC),Self-tapping screw
	27121563Y	Back panel <P>	A71	28324140	Knob,power
	27121565Y	Back panel <W>		28324184	Knob,power <S>
	27121655Y	Back panel <Q>	A72	28324564Y	Knob,level
A9	27300750	Bushing		28324565Y	Knob,level <S>
A10	27190524	KGLS-14R,Holder	A80	29361298A	Label SEM <P>
A13	27273149Y	Joint,power	A81	29360807	Label DANGER
A14	27270214B	Spacer	A82	29361218	Label LASER <P/W/Q>
A16	27255004	CS-1U,Clip	A83	29360811A	Label <P>
A19	834426068	2.6TTS+6B(BC),Self-tapping screw	A84	29361342A	Label SEM/FIN <P>
A20	830440109	4TTC+10C(BC),Self-tapping screw	A85	29360687	Label CLASS1 <P/W/Q>
A21	834430088	3TTS+8B(BC),Self-tapping screw	A86	2000951	NSAS-8P903,Socket
A22	831130088	3TTW+8B,Self-tapping screw	A87	2000952	NSAS-8P904,Socket
A23	833430080	3TTP+8P(BC),Self-tapping screw	A88	2002390810	NSAS-8P0120,Socket
A24	87643010	W3 X 10F(BC),Washer	A89	2002391020	NSAS-10P0119,Socket
A31	27110689Y	Front bracket ass'y 	A97	2061112100	Cord ass'y
	27110690Y	Front bracket ass'y <S>	A99	260208	Binder
A33	28324570Y	Knob,play 	L901	230910	ESD-R-25DB,Core
	28324571A	Knob,play <S>	P901	253163Y or	AS-UC-6#18,
A34	28324578Y	Knob FF 		253174Y	Power supply cord <D>
	28324579Y	Knob FF <S>		253164Y or	AS-CBE250V2.5A,
A35	28324580Y	Knob REP 		253149	Power supply cord <P/W>
	28324581Y	Knob REP <S>		253170	Power supply cord <Q>
A36	28324574Y	Knob TEN 	T901	2300775Y	NPT-1138D,Power transformer <D>
	28324575A	Knob TEN <S>		2300776Y	NPT-1138P,Power transformer <P>
A37	27150344	Shield plate P <S>		2300777Y	NPT-1138DG,Power transformer <W>
A38	27150345	Shield plate <S>		2300778Y	NPT-1138Q,Power transformer <Q>
A41	28184469Y	Top cover	U1	1H194516-1	NAAR-4416-1,Main circuit pc board ass'y <D>
A42	834430088	3TTS+8B(BC),Self-tapping screw		1H194516-1A	NAAR-4416-1A,Main circuit pc board ass'y <P/W/Q>
A43	28140680	0.5 X 8 X 180,Cushion	U2	1H194517-1	NADIS-4417-1,Display circuit pc board ass'y
A51	1H194701K	Front panel ass'y 	U3	1H194518-1	NAAF-4418-1,Headphone amplifier pc board ass'y
	1H195701K	Front panel ass'y <S>	U4	1H194519-1	NAAF-4419-1,Headphone terminal pc board ass'y
	28125222AY	End cap L	U5	1H194520-1	NAPS-4420-1,Power supply circuit pc board ass'y
	28125223AY	End cap R	U6	1H194521-1	NAPS-4421-1,Terminal pc board ass'y

NOTE: :Black model only
<S>:Silver model only
<D>:120V model only
<P>:230V model only
<W>:Worldwide model only
<Q>:240V model only

NOTE: THE COMPONENTS IDENTIFIED BY MARK
▲ ARE CRITICAL FOR RISK OF FIRE AND
ELECTRIC SHOCK. REPLACE ONLY WITH
PART NUMBER SPECIFIED.

PARTS LIST

DX-705

REF.NO.	PARTS NO.	DESCRIPTION	REF. NO.	PART NO.	DESCRIPTION
A1	27100227BY	Chassis	A58	27211396Y	Tray panel
A2	27141520Y	Bracket F	A60	27211398	Tray panel <S>
A3	27141521Y	Bracket R	A61	28191623AY	Clear plate
A4	27130642Y	Bracket C	A62	27175254Y	Leg
A5	27141522Y	Bracket HP	A63	834430088	3TTS+8B(BC),Self-tapping screw
A6	27121566Y	Back panel <D>	A63	833430080	3TTP+8P(BC),Self-tapping screw
	27121567Y	Back panel <P>	A71	28324140	Knob,power
	27121568Y	Back panel <W>		28324184	Knob,power <S>
	27121656Y	Back panel <Q>	A72	28324564Y	Knob,level
A9	27300750	Bushing		28324565Y	Knob,level <S>
A10	27190524	KGLS-14R,Holder	A80	29361298A	Label SEM <P>
A13	27273149Y	Joint,power	A81	29360807	Label DANGER
A14	27270214B	Spacer	A82	29361218	Label LASER <P/W/Q>
A16	27255004	CS-1U,Clip	A83	29360811A	Label <P>
A19	834426068	2.6TTS+6B(BC),Self-tapping screw	A84	29361342A	Label SEM/FIN <P>
A20	830440109	4TTC+10C(BC),Self-tapping screw	A85	29360687	Label CLASS1 <P/W/Q>
A21	834430088	3TTS+8B(BC),Self-tapping screw	A86	2000951	NSAS-8P903,Socket
A22	831130088	3TTW+8B,Self-tapping screw	A87	2000952	NSAS-8P904,Socket
A23	833430080	3TTP+8P(BC),Self-tapping screw	A88	2002390810	NSAS-8P0120,Socket
A24	87643010	W3 X 10F(BC),Washer	A89	2002391020	NSAS-10P0119,Socket
A31	27110689Y	Front bracket ass'y 	A97	2061112100	Cord ass'y
	27110690Y	Front bracket ass'y <S>	A99	260208	Binder
A33	28324570Y	Knob,play 	L901	230910	ESD-R-25DB,Core
	28324571A	Knob,play <S>	P901	253163Y or	AS-UC-6#18,
A34	28324572Y	Knob FF 		253174Y	Power supply cord <D>
	28324573Y	Knob FF <S>		253164Y or	AS-CEE250V2.5A,
A35	28324576Y	Knob REP 		253149	Power supply cord <P/W>
	28324577Y	Knob REP <S>		253170	Power supply cord <Q>
A36	28324574Y	Knob TEN 	T901	2300775Y	NPT-1138D,Power transformer <D>
	28324575A	Knob TEN <S>		2300776Y	NPT-1138P,Power transformer <P>
A37	27150344	Shield plate P <S>		2300777Y	NPT-1138DG,Power transformer <W>
A38	27150345	Shield plate <S>		2300778Y	NPT-1138Q,Power transformer <Q>
A41	28184469Y	Top cover	U1	1H190516-2	NAAR-4416-2,Main circuit pc board ass'y <D>
A42	834430088	3TTS+8B(BC),Self-tapping screw		1H190516-2A	NAAR-4416-2A,Main circuit pc board ass'y <P/W/Q>
A43	28140680	0.5 X 8 X 180,Cushion	U2	1H190517-2	NADIS-4417-2,Display circuit pc board ass'y
A51	1H190701K	Front panel ass'y 	U3	1H190518-2	NAAF-4418-2,Headphone amplifier pc board ass'y
	1H191701K	Front panel ass'y <S>	U4	1H190519-2	NAAF-4419-2,Headphone terminal pc board ass'y
	28125222AY	End cap L	U5	1H190520-2	NAPS-4420-2,Power supply circuit pc board ass'y
	28125223AY	End cap R			

NOTE: :Black model only
<S>:Silver model only
<D>:120V model only
<P>:230V model only
<W>:Worldwide model only
<Q>:240V model only

**NOTE: THE COMPONENTS IDENTIFIED BY MARK
▲ ARE CRITICAL FOR RISK OF FIRE AND
ELECTRIC SHOCK. REPLACE ONLY WITH
PART NUMBER SPECIFIED.**

▲ ESD-R-25DB,Core
▲ AS-UC-6#18,
▲ Power supply cord <D>
▲ AS-CEE250V2.5A,
▲ Power supply cord <P/W>
▲ Power supply cord <Q>
▲ NPT-1138D,Power transformer <D>
▲ NPT-1138P,Power transformer <P>
▲ NPT-1138DG,Power transformer <W>
▲ NPT-1138Q,Power transformer <Q>
▲ NAAR-4416-2,Main circuit pc board ass'y <D>
▲ NAAR-4416-2A,Main circuit pc board ass'y <P/W/Q>
▲ NADIS-4417-2,Display circuit pc board ass'y
▲ NAAF-4418-2,Headphone amplifier pc board ass'y
▲ NAAF-4419-2,Headphone terminal pc board ass'y
▲ NAPS-4420-2,Power supply circuit pc board ass'y

SCHEMATIC DIAGRAM

MODEL DX-703

A B C D E F G H

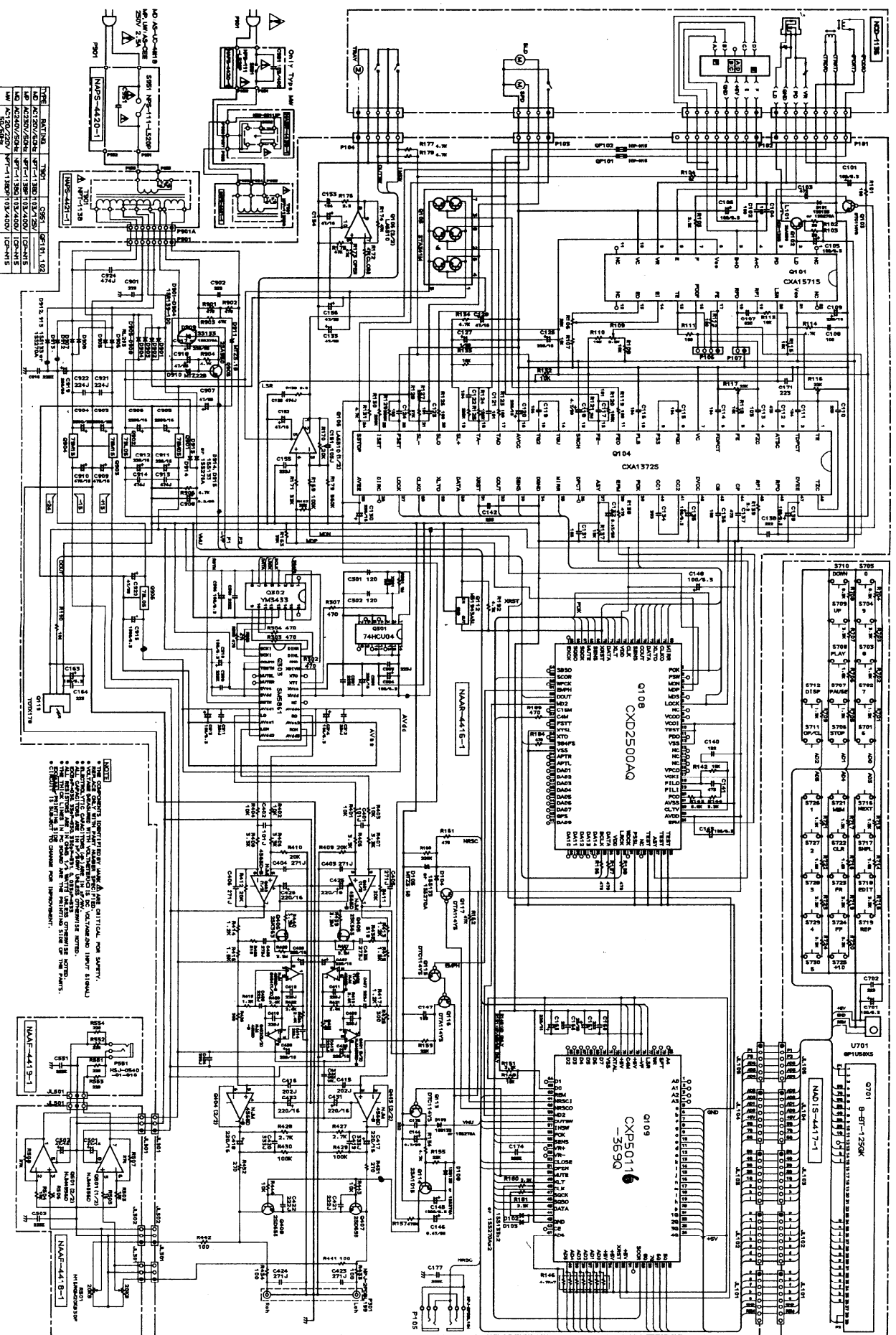

TYPE	PART NO.	QTY	REF. DES.
IC	CX15725	1	IC15725
IC	CXD2500AQ	1	IC2500AQ
IC	CXP011-5690	1	IC5690
IC	NAAD-S-4417-1	1	IC4417-1
RES	VARIOUS	VARIOUS	VARIOUS
CAP	VARIOUS	VARIOUS	VARIOUS
DIODE	VARIOUS	VARIOUS	VARIOUS

NOTE:
 1. THE SCHEMATIC DIAGRAM IS FOR REFERENCE ONLY. THE ACTUAL PARTS LIST IS THE AUTHORITY FOR PARTS IDENTIFICATION.
 2. THE SCHEMATIC DIAGRAM IS NOT TO BE USED FOR REPAIR OR RECONSTRUCTION.
 3. THE SCHEMATIC DIAGRAM IS NOT TO BE USED FOR REPAIR OR RECONSTRUCTION.
 4. THE SCHEMATIC DIAGRAM IS NOT TO BE USED FOR REPAIR OR RECONSTRUCTION.
 5. THE SCHEMATIC DIAGRAM IS NOT TO BE USED FOR REPAIR OR RECONSTRUCTION.

SCHEMATIC DIAGRAM

MODEL DX-705

A B C D E F G H

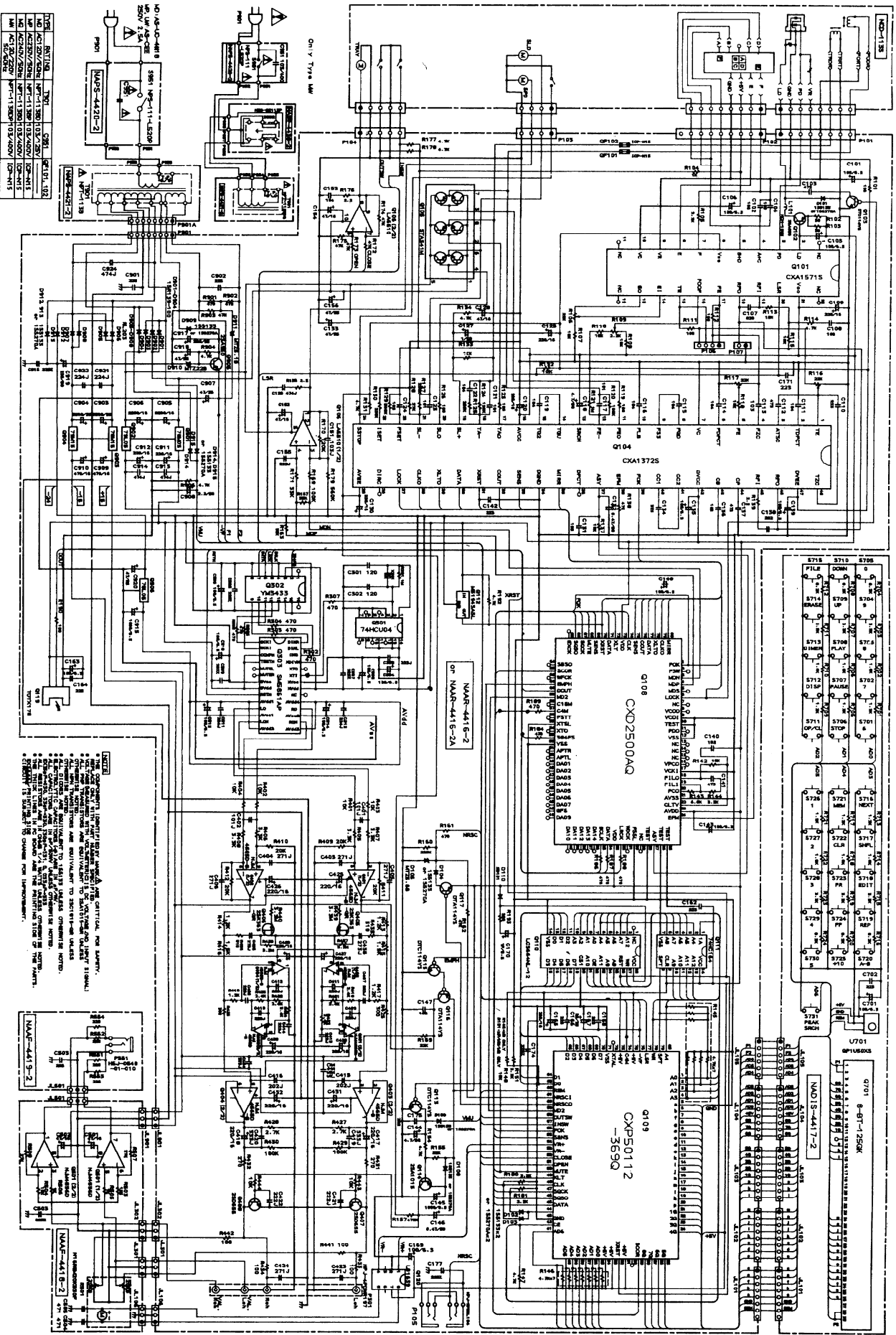

NO.	PART NAME	QTY	REF.	SYMBOL	DESCRIPTION
101	RESISTOR	1	R101	10K	10K OHM 1/4W
102	RESISTOR	1	R102	10K	10K OHM 1/4W
103	RESISTOR	1	R103	10K	10K OHM 1/4W
104	RESISTOR	1	R104	10K	10K OHM 1/4W
105	RESISTOR	1	R105	10K	10K OHM 1/4W
106	RESISTOR	1	R106	10K	10K OHM 1/4W
107	RESISTOR	1	R107	10K	10K OHM 1/4W
108	RESISTOR	1	R108	10K	10K OHM 1/4W
109	RESISTOR	1	R109	10K	10K OHM 1/4W
110	RESISTOR	1	R110	10K	10K OHM 1/4W
111	RESISTOR	1	R111	10K	10K OHM 1/4W
112	RESISTOR	1	R112	10K	10K OHM 1/4W
113	RESISTOR	1	R113	10K	10K OHM 1/4W
114	RESISTOR	1	R114	10K	10K OHM 1/4W
115	RESISTOR	1	R115	10K	10K OHM 1/4W
116	RESISTOR	1	R116	10K	10K OHM 1/4W
117	RESISTOR	1	R117	10K	10K OHM 1/4W
118	RESISTOR	1	R118	10K	10K OHM 1/4W
119	RESISTOR	1	R119	10K	10K OHM 1/4W
120	RESISTOR	1	R120	10K	10K OHM 1/4W
121	RESISTOR	1	R121	10K	10K OHM 1/4W
122	RESISTOR	1	R122	10K	10K OHM 1/4W
123	RESISTOR	1	R123	10K	10K OHM 1/4W
124	RESISTOR	1	R124	10K	10K OHM 1/4W
125	RESISTOR	1	R125	10K	10K OHM 1/4W
126	RESISTOR	1	R126	10K	10K OHM 1/4W
127	RESISTOR	1	R127	10K	10K OHM 1/4W
128	RESISTOR	1	R128	10K	10K OHM 1/4W
129	RESISTOR	1	R129	10K	10K OHM 1/4W
130	RESISTOR	1	R130	10K	10K OHM 1/4W
131	RESISTOR	1	R131	10K	10K OHM 1/4W
132	RESISTOR	1	R132	10K	10K OHM 1/4W
133	RESISTOR	1	R133	10K	10K OHM 1/4W
134	RESISTOR	1	R134	10K	10K OHM 1/4W
135	RESISTOR	1	R135	10K	10K OHM 1/4W
136	RESISTOR	1	R136	10K	10K OHM 1/4W
137	RESISTOR	1	R137	10K	10K OHM 1/4W
138	RESISTOR	1	R138	10K	10K OHM 1/4W
139	RESISTOR	1	R139	10K	10K OHM 1/4W
140	RESISTOR	1	R140	10K	10K OHM 1/4W
141	RESISTOR	1	R141	10K	10K OHM 1/4W
142	RESISTOR	1	R142	10K	10K OHM 1/4W
143	RESISTOR	1	R143	10K	10K OHM 1/4W
144	RESISTOR	1	R144	10K	10K OHM 1/4W
145	RESISTOR	1	R145	10K	10K OHM 1/4W
146	RESISTOR	1	R146	10K	10K OHM 1/4W
147	RESISTOR	1	R147	10K	10K OHM 1/4W
148	RESISTOR	1	R148	10K	10K OHM 1/4W
149	RESISTOR	1	R149	10K	10K OHM 1/4W
150	RESISTOR	1	R150	10K	10K OHM 1/4W
151	RESISTOR	1	R151	10K	10K OHM 1/4W
152	RESISTOR	1	R152	10K	10K OHM 1/4W
153	RESISTOR	1	R153	10K	10K OHM 1/4W
154	RESISTOR	1	R154	10K	10K OHM 1/4W
155	RESISTOR	1	R155	10K	10K OHM 1/4W
156	RESISTOR	1	R156	10K	10K OHM 1/4W
157	RESISTOR	1	R157	10K	10K OHM 1/4W
158	RESISTOR	1	R158	10K	10K OHM 1/4W
159	RESISTOR	1	R159	10K	10K OHM 1/4W
160	RESISTOR	1	R160	10K	10K OHM 1/4W
161	RESISTOR	1	R161	10K	10K OHM 1/4W
162	RESISTOR	1	R162	10K	10K OHM 1/4W
163	RESISTOR	1	R163	10K	10K OHM 1/4W
164	RESISTOR	1	R164	10K	10K OHM 1/4W
165	RESISTOR	1	R165	10K	10K OHM 1/4W
166	RESISTOR	1	R166	10K	10K OHM 1/4W
167	RESISTOR	1	R167	10K	10K OHM 1/4W
168	RESISTOR	1	R168	10K	10K OHM 1/4W
169	RESISTOR	1	R169	10K	10K OHM 1/4W
170	RESISTOR	1	R170	10K	10K OHM 1/4W
171	RESISTOR	1	R171	10K	10K OHM 1/4W
172	RESISTOR	1	R172	10K	10K OHM 1/4W
173	RESISTOR	1	R173	10K	10K OHM 1/4W
174	RESISTOR	1	R174	10K	10K OHM 1/4W
175	RESISTOR	1	R175	10K	10K OHM 1/4W
176	RESISTOR	1	R176	10K	10K OHM 1/4W
177	RESISTOR	1	R177	10K	10K OHM 1/4W
178	RESISTOR	1	R178	10K	10K OHM 1/4W
179	RESISTOR	1	R179	10K	10K OHM 1/4W
180	RESISTOR	1	R180	10K	10K OHM 1/4W
181	RESISTOR	1	R181	10K	10K OHM 1/4W
182	RESISTOR	1	R182	10K	10K OHM 1/4W
183	RESISTOR	1	R183	10K	10K OHM 1/4W
184	RESISTOR	1	R184	10K	10K OHM 1/4W
185	RESISTOR	1	R185	10K	10K OHM 1/4W
186	RESISTOR	1	R186	10K	10K OHM 1/4W
187	RESISTOR	1	R187	10K	10K OHM 1/4W
188	RESISTOR	1	R188	10K	10K OHM 1/4W
189	RESISTOR	1	R189	10K	10K OHM 1/4W
190	RESISTOR	1	R190	10K	10K OHM 1/4W
191	RESISTOR	1	R191	10K	10K OHM 1/4W
192	RESISTOR	1	R192	10K	10K OHM 1/4W
193	RESISTOR	1	R193	10K	10K OHM 1/4W
194	RESISTOR	1	R194	10K	10K OHM 1/4W
195	RESISTOR	1	R195	10K	10K OHM 1/4W
196	RESISTOR	1	R196	10K	10K OHM 1/4W
197	RESISTOR	1	R197	10K	10K OHM 1/4W
198	RESISTOR	1	R198	10K	10K OHM 1/4W
199	RESISTOR	1	R199	10K	10K OHM 1/4W
200	RESISTOR	1	R200	10K	10K OHM 1/4W

NOTE:
 1. THE COMPONENTS IDENTIFIED BY A TRIANGLE ARE CRITICAL TO SAFETY.
 2. THE COMPONENTS IDENTIFIED BY A TRIANGLE ARE CRITICAL TO THE PROPER OPERATION OF THE UNIT.
 3. THE COMPONENTS IDENTIFIED BY A TRIANGLE ARE CRITICAL TO THE PROPER OPERATION OF THE UNIT.
 4. THE COMPONENTS IDENTIFIED BY A TRIANGLE ARE CRITICAL TO THE PROPER OPERATION OF THE UNIT.
 5. THE COMPONENTS IDENTIFIED BY A TRIANGLE ARE CRITICAL TO THE PROPER OPERATION OF THE UNIT.
 6. THE COMPONENTS IDENTIFIED BY A TRIANGLE ARE CRITICAL TO THE PROPER OPERATION OF THE UNIT.
 7. THE COMPONENTS IDENTIFIED BY A TRIANGLE ARE CRITICAL TO THE PROPER OPERATION OF THE UNIT.
 8. THE COMPONENTS IDENTIFIED BY A TRIANGLE ARE CRITICAL TO THE PROPER OPERATION OF THE UNIT.
 9. THE COMPONENTS IDENTIFIED BY A TRIANGLE ARE CRITICAL TO THE PROPER OPERATION OF THE UNIT.
 10. THE COMPONENTS IDENTIFIED BY A TRIANGLE ARE CRITICAL TO THE PROPER OPERATION OF THE UNIT.

MECHANISM-EXPLODED VIEW

PICKUP DRIVE UNIT-EXPLODED VIEW

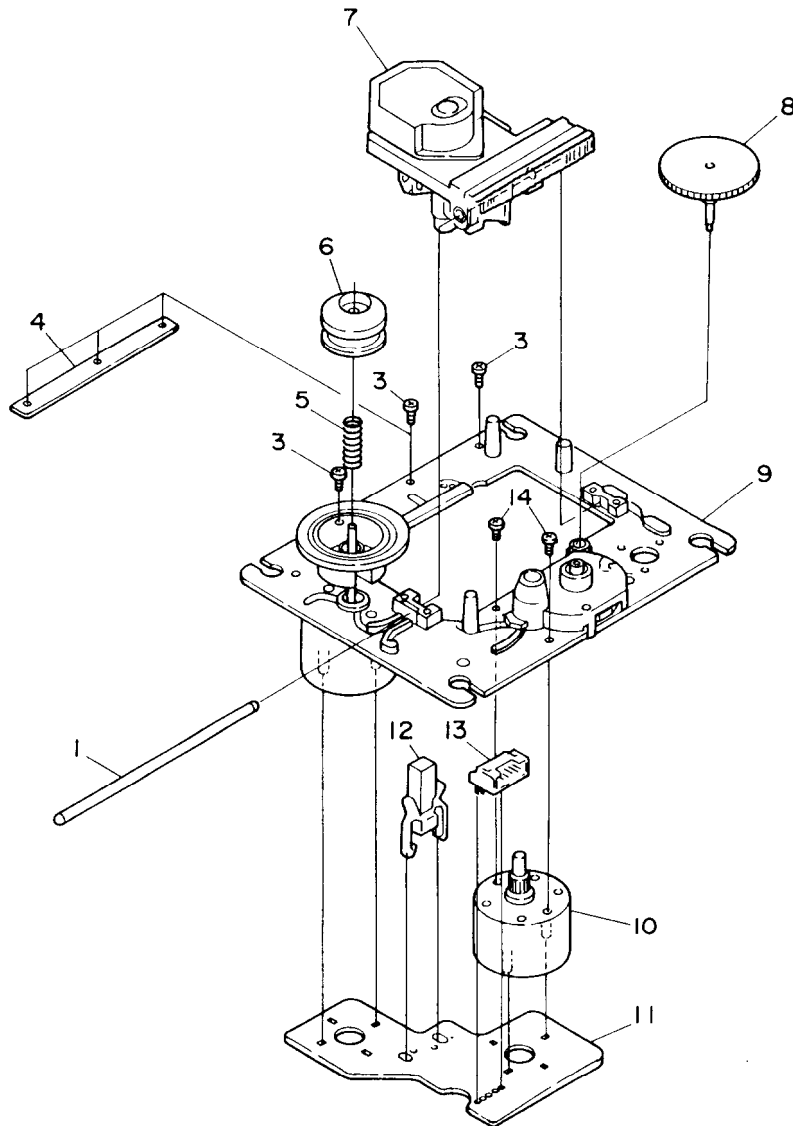

PARTS LIST

REF.NO.	PART NO.	DESCRIPTION	REF.NO.	PART NO.	DESCRIPTION
1	24828003	Sled shaft	8	24810006	Wheel
2			9	24802003	Turntable chassis
3	801425	2×5,Self-tapping screw	10	24804004	Motor gear
4	24822004	Plate	11	24840007	Motor pc board
5	24820003	Spring	12	24840008	Leafswitch
6	24822005	Center ring	13	25050396	NSCT-4P223,Connector
7	24110008	KSS-210A,Optical pickup	14	82142003	2P+3F(BC),Pan head screw

PARTS LIST

REF.NO.	PART NO.	DESCRIPTION	REF.NO.	PART NO.	DESCRIPTION
1	24506878	Tray	26	24602507	Belt
2	24506897	Damper	27	870144	Washer
3	28140980	Front tape	28	24506884	Loading pulley
4	838430108	3TTB+10B(BC),Self-tapping screw	29	833120047	2TTP+4S,Tapping screw
5	24506959	Chucking pulley	30	27301227	Middle gear
6	24506876	Chucking chassis	31	27301230	Tray holder
7	834126069	2.6TTS+6C,Self-tapping screw	32	24506888	Tray guide,left
8	24818004	Yoke damper	33	24506887	Tray guide,right
9	24832003	Magnet	34	838426038	2.6TTB+3C(BC),Self-tapping screw
10	24830001	Chucking yoke	35	27301228	Tray holder,front
11	24506879	Gear cover	36	27301224	Main chassis
12	801424	Screw with washer	37	24506890	Boss,back
13		KSM-2101AAM,Pickup drive unit	38	834120049	2TTS+4C,Self-tapping screw
14	24506870	Roller	39	25065402	Leafswitch
15	24506871	Plate	40	24506889	Boss,right
16	24506898	Sub chassis	41	24506890	Boss,left
17	24509401	Insulator	42	24506883	Control cam
18	27180442	Spring A	43	24506892	Link plate
19	27180441	Spring B	44	24506894	Stopper link
20		Shaft	45	24506893	Boss
21	24506864	Hinge holder	46	24506895	Spacer
22		Hinge	47	83112608	2.6TTW+8S,Self-tapping screw
23	838426108	2.6TTB+10B(BC),Self-tapping screw	48	25050393	Connector pin
24	8761301008	W3 × 10F,Washer	49	24505269	Motor pc board
25	24506882	Drive gear	50	24506886	Motor ass'y

REMOVEMENT OF DISC TRAY

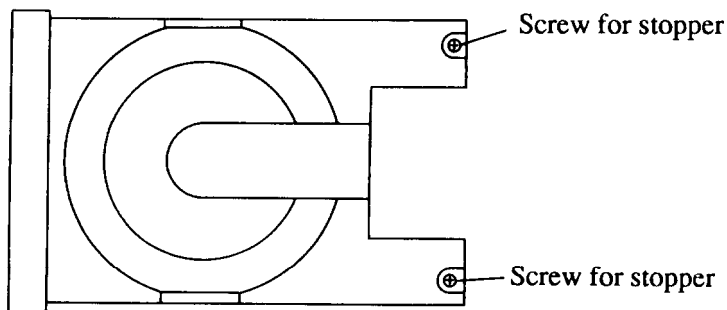

1. Loosen the screw for stopper until the head of screw and the tray are the same height.
2. Turn POWER switch to on.
3. Press OPEN/CLOSE button to open the tray.
4. Turn POWER switch to off.
5. Remove the tray.

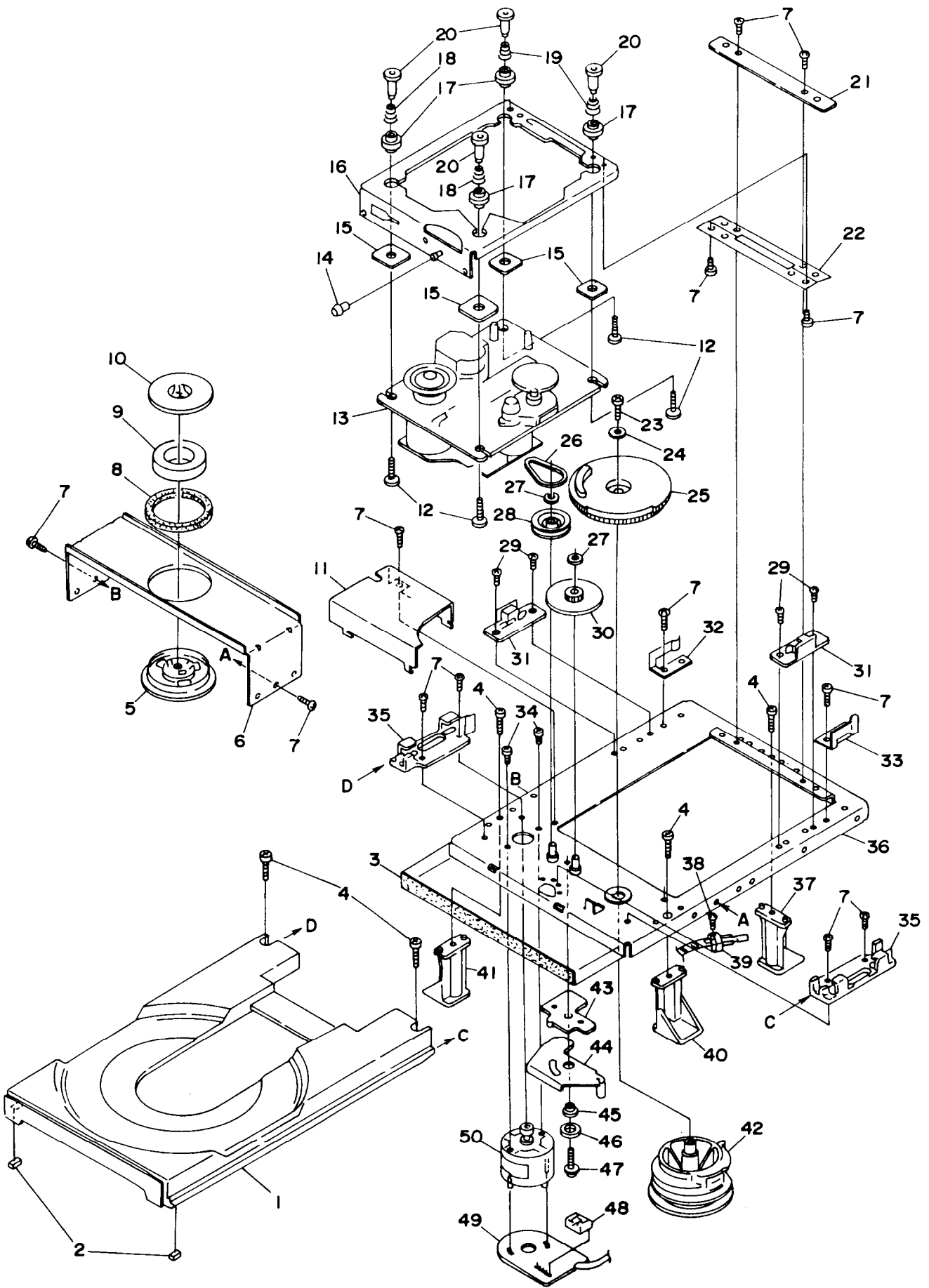

ADJUSTMENT PROCEDURES

Instruments required

Dual trace oscilloscope, Frequency counter, AF oscillator, Test disc (SONY YEDS-18), AC voltmeter, Jitter meter, and Socket P4(Part no. 25050138)

1. Focus offset adjustment

Load the test disc YEDS-18 on the tray and play the track 2.

Connect the oscilloscope or jitter meter to terminal P106.

(Oscilloscope)

Adjust R109 until a clear trace of waveform pattern as shown photo 1 appear on the oscilloscope.

When the amount of jitter is broad, set R109 to mechanical center.

(Jitter meter)

Adjust R109 until the jitter meter reading becomes minimum.(Less than 10ns.)

After adjustment, disconnect the oscilloscope or jitter meter.

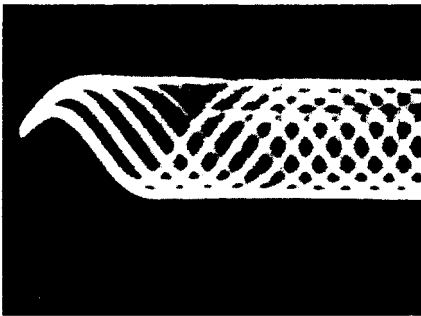
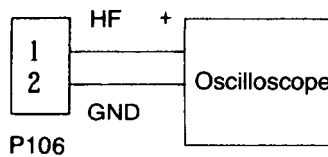
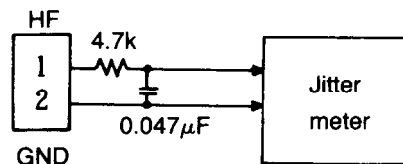

Photo 1



Oscilloscope range
Vertical : 0.5V/div.
Horizontal : 0.5 μ s/div.
DC, Ground: Center



2. Tracking offset adjustment

Load the test disc YEDS-18 on the tray and play the track 2.

Turn R116 to minimum position.(Counter clockwise)

Connect the oscilloscope between pin 3 (TR) of P107 and pin 2 (GND) of P106.

Adjust R106 until the center of tracking error signal on the oscilloscope becomes GND level.

Turn R116 to the mechanical center.

After adjustment, disconnect the oscilloscope.

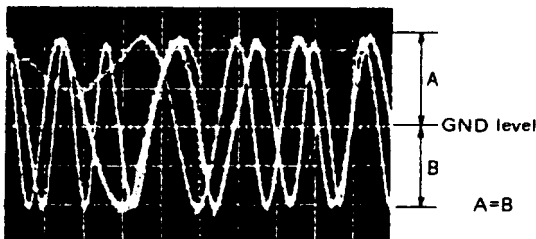
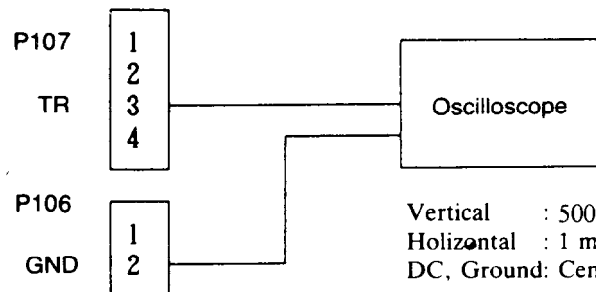

Photo 2



Vertical : 500mV/div.
Horizontal : 1 ms/div.
DC, Ground: Center

3. Focus gain adjustment

Set the output of AF oscillator to 1kHz, 1~1.5Vp-p.

Play the track 2 of test disc.

Connect the oscilloscope and the AF oscillator as shown below.

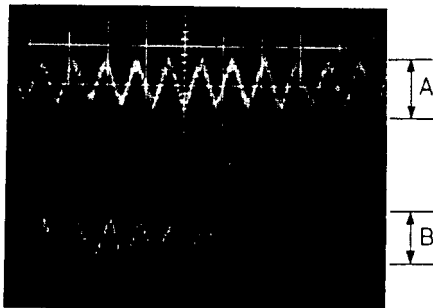
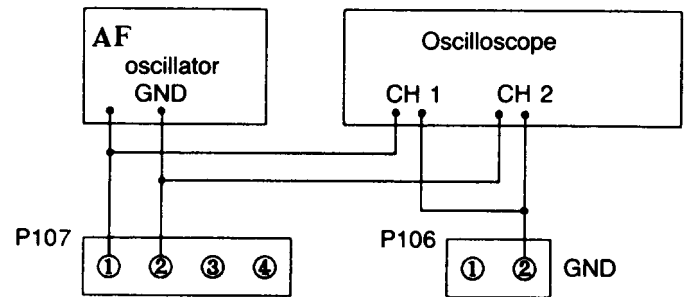

Photo 3



Vertical : 0.2V/div.
Horizontal: 0.2 ms/div.

Adjust R117 until 1kHz components of channels 1 and 2 on oscilloscope become same level.

After adjustment, disconnect the AF oscillator and the oscilloscope.

4. Tracking gain adjustment

Set the output of AF oscillator to 1.2kHz, 1~1.5Vp-p.

Play the track 2 of test disc.

Connect the oscilloscope and the AF oscillator as shown below.

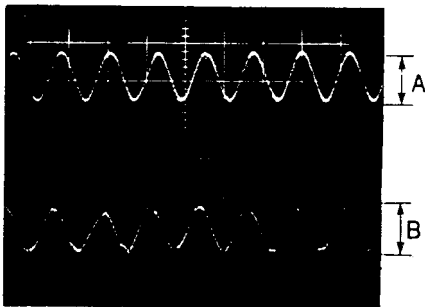
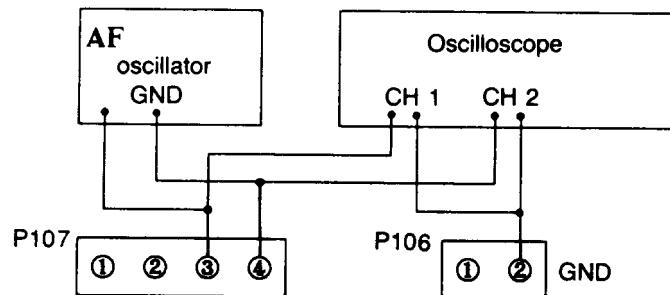

Photo 4



Vertical : 0.2V/div.
Horizontal: 0.2 ms/div.

Adjust R116 until 1.2kHz components of channels 1 and 2 on oscilloscope become same level.

After adjustment, disconnect the AF oscillator and the oscilloscope.

After adjustment, confirm that the center of tracking error signal becomes GND level.

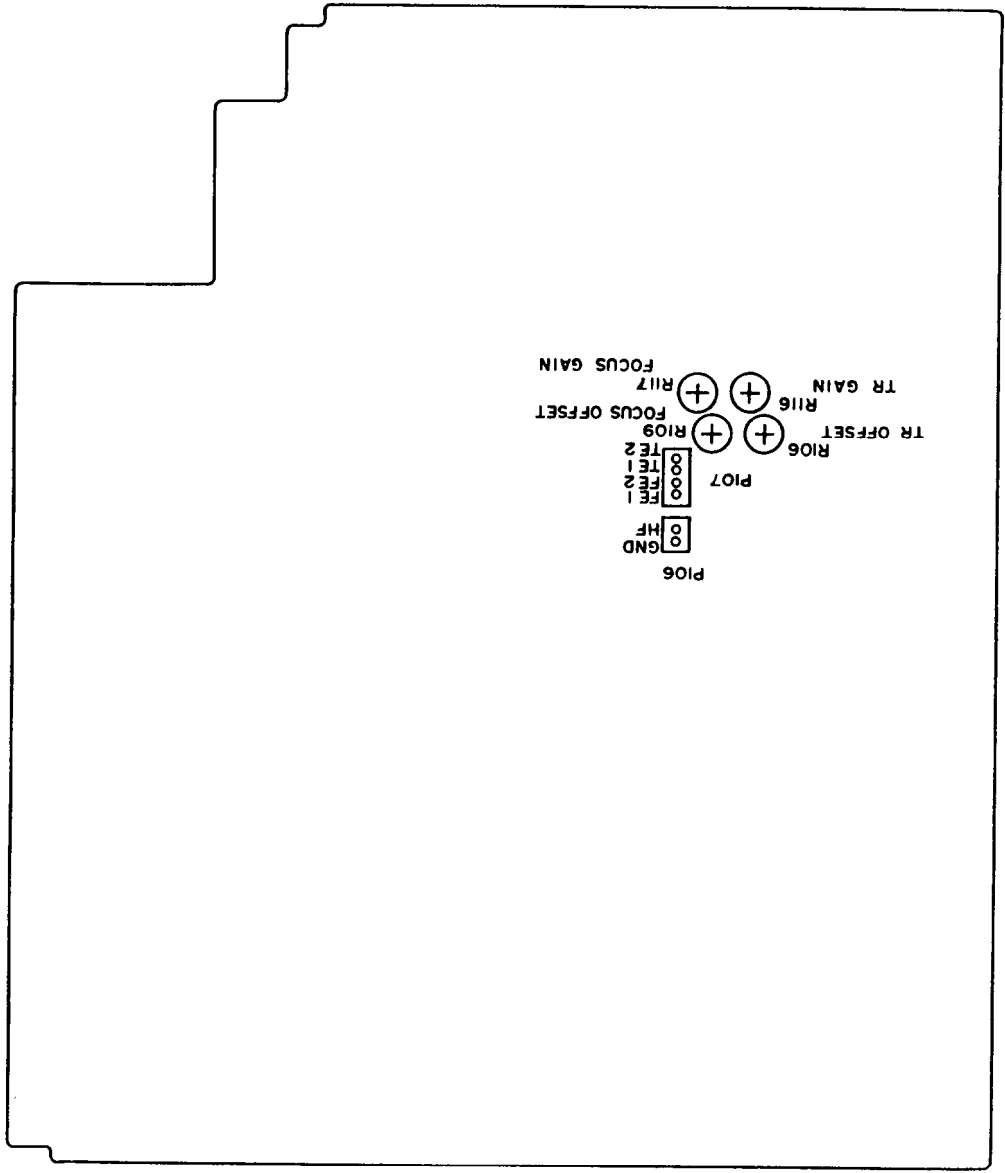

PRINTED CIRCUIT BOARD-PARTS LIST

MAIN CIRCUIT PC BOARD(NAAR-4416-1/1A/2/2A)

CIRCUIT NO.	PART NO.	DESCRIPTION	CIRCUIT NO.	PART NO.	DESCRIPTION
	ICs				
Q101	22240404	CXA1571S	C101,C105	354721019	100 μ F,6.3V,Elect.
Q104	22240366	CXA1372S	C103,C137	374724724	4700pF \pm 5%,50V,Plastic
Q106	22240034	LA6510	C106	354721019	100 μ F,6.3V,Elect.
Q108	22240487	CXD2500AQ	C109,C120	354742219	220 μ F,16V,Elect.
Q109	22240585	CXP50116-369Q	C110	374722234	0.022 μ F \pm 5%,50V,Plastic
Q110	22240198	LC3664NL-12	C111	374721044	0.1 μ F \pm 5%,50V,Plastic
Q111	222741645	74HC164	C112,C141	374724734	0.047 μ F \pm 5%,50V,Plastic
Q112	22240018	M51943ASL	C113,C124	374721034	0.01 μ F \pm 5%,50V,Plastic
Q120	22240322	LB1639	C114-C116	374721044	0.1 μ F \pm 5%,50V,Plastic
Q301	222755	74HC04P	C118,C144	354780479	4.7 μ F,50V,Elect.
Q302	22240321	YM3433	C119,C122	374721044	0.1 μ F \pm 5%,50V,Plastic
Q303	22240520	SM5861AP	C125,C130	354742219	220 μ F,16V,Elect.
Q401-Q404	22240201	NJM4565D-B	C127	354780109	1 μ F,50V,Elect.
Q901	222780055MIT	M5F78M05L	C128,C152	354744709	47 μ F,16V,Elect.
Q902	222790053	79L05	C129	374724744	0.47 μ F \pm 5%,50V,Plastic
Q903	222780155MIT	M5F78M15L	C131,C136	374721034	0.01 μ F \pm 5%,50V,Plastic
Q904	222790155MIT	M5F79M15L	C132	354784799	0.47 μ F,50V,Elect.
Q906	222780053	78L05	C133,C156	354764709	47 μ F,35V,Elect.
	Transistors		C134	374723334	0.033 μ F \pm 5%,50V,Plastic
Q102,Q905	2211503 or	2SA950-O or	C135,C139	354721019	100 μ F,6.3V,Elect.
	2211504	2SA950-Y	C138,C155	374722224	2200pF \pm 5%,50V,Plastic
Q103	221281	DTC114YS	C140	374721524	1500pF \pm 5%,50V,Plastic
Q105	22240168	STA341M-L	C143	354721019	100 μ F,6.3V,Elect.
Q113,Q115	221281	DTC114YS	C145	354721029	1000 μ F,6.3V,Elect.
Q114	2211455	2SA1015-GR	C146	354784799	0.47 μ F,50V,Elect.
Q116,Q117	2213090	DTA114YS	C147,C151	374721034	0.01 μ F \pm 5%,50V,Plastic
Q405,Q406	2212524	2SK363-GR	C148,C149	354721019	100 μ F,6.3V,Elect.
Q407,Q408	2211705 or	2SD655-E or	C153	374721044	0.1 μ F \pm 5%,50V,Plastic
	2211706	2SD655-F	C154	354744709	47 μ F,16V,Elect.
	Opto.module		C163	354721019	100 μ F,6.3V,Elect.
Q119	24120031	TOTX178,Transmitter	C165	354742219	220 μ F,16V,Elect.
	IC protectors		C167	354762209	22 μ F,35V,Elect.
QF101,QF102	252112	 ICP-N15 <P>	C169	354721019	100 μ F,6.3V,Elect.
	Diodes		C170	3000058	1 μ F,5.5V,Super
D101-D104	223163 or	1SS133 or	C175	374722224	2200pF \pm 5%,50V,Plastic
D108,D109	223205	1SS270A	C304,C306	354721019	100 μ F,6.3V,Elect.
D105	224450562	MTZ5.6B	C308	354742219	220 μ F,16V,Elect.
D110	223191	SD101	C310	354721019	100 μ F,6.3V,Elect.
D901-D904	22380032	1SR139-100	C311,C312	374722244	0.22 μ F \pm 5%.50V.Plastic
D905-D908	22380045	RL203	C313,C314	354721019	100 μ F,6.3V,Elect.
D909	223163 or	1SS133 or	C401,C402	373301014	100pF \pm 5%,125V,PP
D912-D915	223205	1SS270A	C403-C406	373302714	270pF \pm 5%,125V,PP
D910	224452202	MTZ22B	C407,C408	374722224	2200pF \pm 5%,50V,Plastic
D911	224450512	MTZ5.1B	C413,C414	374722224	2200pF \pm 5%,50V,Plastic
	X'tal		C415,C416	372122024	2000pF \pm 5%,50V,Styrole
X301	3010159	AT-38-169	C417,C418	354742219	220 μ F,16V,Elect.
	Coil		C419,C420	374723334	0.033 μ F \pm 5%,50V,Plastic
L101	233411K100	NCH-1383	C421,C422	374722224	2200pF \pm 5%,50V,Plastic
			C423,C424	373302714	270pF \pm 5%,125V,PP

CIRCUIT NO.	PART NO.	DESCRIPTION
	Capacitors	
C425-C432	354742219	220 μ F,16V,Elect.
C433,C434	374723334	0.033 μ F \pm 5%,50V,Plastic
C435,C436	374722734	0.027 μ F \pm 5%,50V,Plastic
C903,C904	393163327	3300 μ F,35V,Elect.
C905,C906	354742229	2200 μ F,16V,Elect.
C907,C918	354764709	47 μ F,35V,Elect.
C908	354780229	2.2 μ F,50V,Elect.
C909,C910	354744719	470 μ F,16V,Elect.
C911,C912	354742219	220 μ F,16V,Elect.
C913,C914	375624744	0.47 μ F \pm 5%,50V,Plastic
C915	354721029	1000 μ F,6.3V,Elect.
C917	354762219	220 μ F,35V,Elect.
C919	354764719	470 μ F,35V,Elect.
C920	354764709	47 μ F,35V,Elect.
C921,C922	374722244	0.22 μ F \pm 5%,50V,Plastic
C924	374724744	0.47 μ F \pm 5%,50V,Plastic
	Resistors	
R106	5210066	N06HR22KBD,Semi-fixed
R109	5210060	N06HR2.2KBD,Semi-fixed
R116,R117	5210066	N06HR22KBD,Semi-fixed
R145	49163472407	⊙ RM1/101J 4.7K \times 7,Array
R146	49163472407	RM1/101J 4.7K \times 7,Array
	Plugs	
P101	25055152	NPLG-8P136
P102	25055153	NPLG-9P137
P103	25055148	NPLG-4P132
P104	25055149	NPLG-5P133
P106	25055038	NPLG-2P29
P107	25055045	NPLG-4P33
P901	25055138	NPLG-8P122
	Jack	
P105	25045330	NPJ-2PDBL184
	Terminal	
P301	25045353	● NPJ-2PDBL199,Output
	25045351	⊙ NPJ-4PDWR197,Output
	Holder	
	27190751	

DISPLAY CIRCUIT PC BOARD(NADIS-4417-1/2)

CIRCUIT NO.	PART NO.	DESCRIPTION
U701	24130003	GP1U50XS,Remote control sensor
S701-S712	25035548	NPS-111-S510,Push switches
S713-S715	25035548	⊙ NPS-111-S510,Push switches
S716-S719	25035548	NPS-111-S510,Push switches
S720,S731	25035548	⊙ NPS-111-S510,Push switches
S721-S730	25035548	NPS-111-S510,Push switches
Q701	212109	8-BT-125GK,FL tube
C701	353721019	100 μ F,6.3V,Elect. capacitor
	27190754Y	Holder FL

HEADPHONE AMPLIFIER PC BOARD(NAAF-4418-1/2)

CIRCUIT NO.	PART NO.	DESCRIPTION
Q501	222654	NJM4556D,IC
C501,C502	354744709	47 μ F,16V,Elect. capacitor
R501	5142005A	● N16RGM20KB30F, Variable resistor
	5104242	⊙ N16RGM20KB30F, Variable resistor

HEADPHONE TERMINAL PC BOARD(NAAF-4419-1/2)

CIRCUIT NO.	PART NO.	DESCRIPTION
P551	25045139	HSJ-0540-01-010, Headphone jack

POWER SUPPLY CIRCUIT PC BOARD(NAPS-4420-1/2)

CIRCUIT NO.	PART NO.	DESCRIPTION
C951	3500065A	⚠ DE7150FZ103PAC400V/ 125V,IS capacitor
S951	25035558	⚠ NPS-111-S520P, Power switch

TERMINAL PC BOARD(NAPS-4421-1/2)

CIRCUIT NO.	PART NO.	DESCRIPTION
	2001191615	NSAS-16P0295,Socket

VOLTAGE SELECTOR SWITCH PC BOARD(NASW-4438-1/2)

Worldwide model only

CIRCUIT NO.	PART NO.	DESCRIPTION
S952	25065287	⚠ NSS-22113P,Slide switch

NOTE: ●:DX-703 only

⊙:DX-705 only

<P>:Except 120V model

NOTE: THE COMPONENTS IDENTIFIED BY MARK ⚠ ARE CRITICAL FOR RISK OF FIRE AND ELECTRIC SHOCK. REPLACE ONLY WITH PART NUMBER SPECIFIED.

BLOCK DIAGRAM

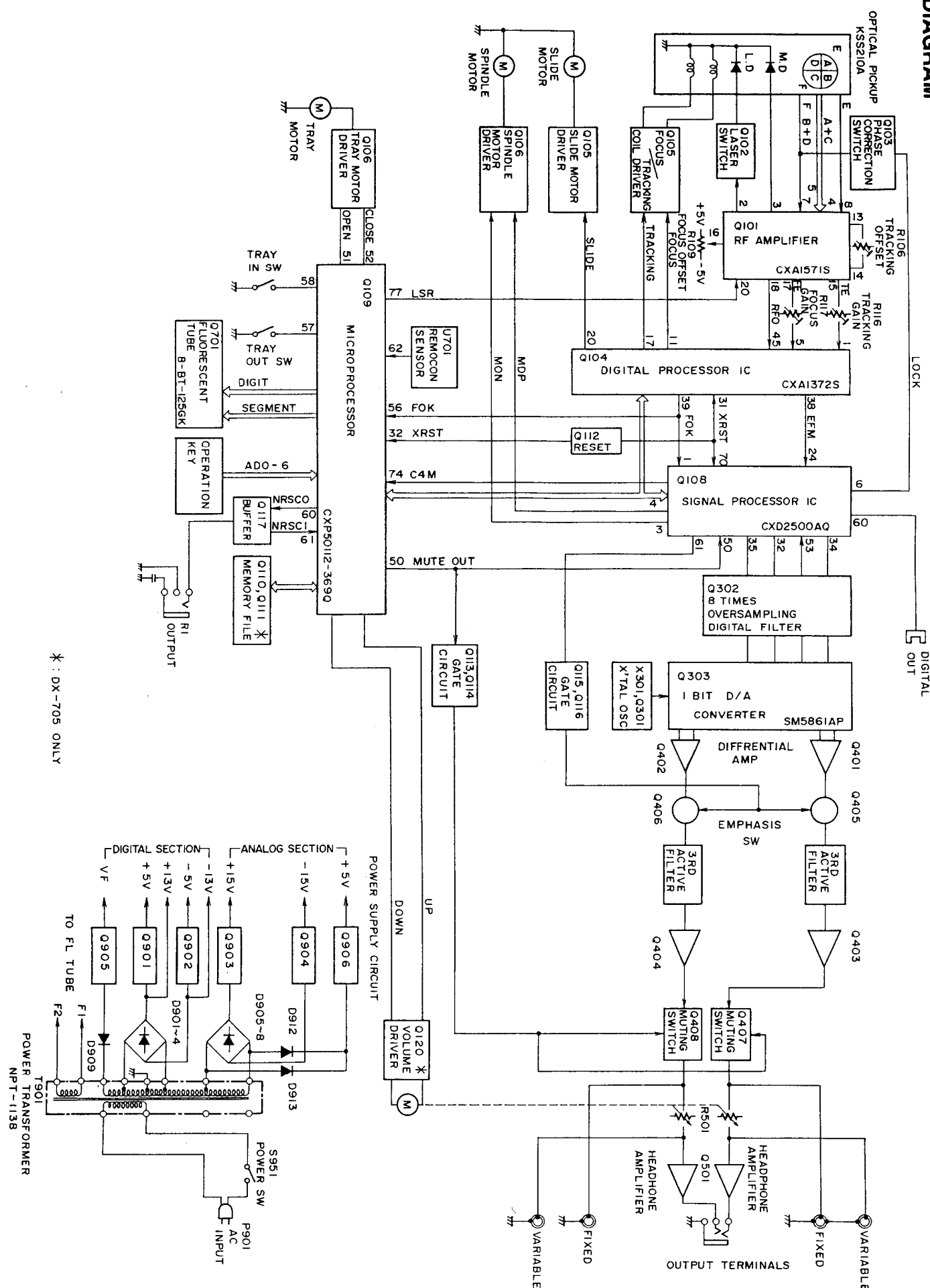

* : DX-705 ONLY