

ONKYO® SERVICE MANUAL

COMPACT DISC PLAYER MODEL DX-706/MODEL DX-708

Black and Silver models

UDN, UD	120V AC, 60 Hz
UP	230V AC, 50Hz
UW	120/220V AC, 50/60Hz
UQA	240V AC, 50 Hz

SAFETY-RELATED COMPONENT WARNING!!

COMPONENTS IDENTIFIED BY MARK  ON THE SCHEMATIC DIAGRAM AND IN THE PARTS LIST ARE CRITICAL FOR RISK OF FIRE AND ELECTRIC SHOCK. REPLACE THESE COMPONENTS WITH ONKYO PARTS WHOSE PARTS NUMBERS APPEAR AS SHOWN IN THIS MANUAL.

MAKE LEAKAGE-CURRENT OR RESISTANCE MEASUREMENTS TO DETERMINE THAT EXPOSED PARTS ARE ACCEPTABLY INSULATED FROM THE SUPPLY CIRCUIT BEFORE RETURNING THE APPLIANCE TO THE CUSTOMER.



SPECIFICATIONS

	Model DX-706	DX-708
Signal readout system:	Optical non-contact	Optical non-contact
Reading rotation:	About 500-200 r.p.m. (constant linear velocity)	About 500-200 r.p.m. (constant linear velocity)
Linear velocity:	1.2-1.4m/s	1.2-1.4m/s
Error correction system:	Cross interleave Reed Solomon code	Cross interleave Reed Solomon code
D/A converter:	1 BIT PWM × 2 AccuPulse Quartz System	1 BIT PWM × 2 AccuPulse Quartz System
Sampling frequency:	352.8kHz (eight-times oversampling)	352.8kHz (eight-times oversampling)
Number of channels:	2 (stereo)	2 (stereo)
Frequency response:	2 Hz-20kHz	2 Hz-20kHz
Total harmonic distortion:	0.0020% (at 1 kHz)	0.0020% (at 1 kHz)
Dynamic range:	100dB	100dB
Signal to noise ratio:	110dB	110dB
Channel separation:	110dB (at 1 kHz)	110dB (at 1 kHz)
Wow and Flutter:	Below threshold of measurability	Below threshold of measurability
Output level:	2 volts r.m.s.	2 volts r.m.s.
Power consumption:	21 watts	21 watts
Dimensions (W×H×D):	445×130×364mm 17-15/16" × 5-1/8" × 14-5/16"	455×130×364mm 17-15/16" × 5-1/8" × 14-5/16"
Weight:	8kg, 17.6 lbs.	8.8kg, 19.4 lbs.

Specifications and external appearance are subject to change without notice because of product improvements.

SERVICE PROCEDURES

1. How to Release the Transport Lock

To protect the optical assembly including the laser pickup from vibration related damage during shipping, this unit is equipped with a transport lock lever located on the base.

- Loosen the screw with Phillips screwdriver.
- Move the lock lever in the direction opposite that shown by the arrow. Move the lever up to the position where it can move no farther, and then remove the lever.

■ Tighten the screw to secure the lock lever.

- For shipping, restore the lock lever to its position in the direction of the arrow, then tighten down the screw to secure the lock lever in that position.

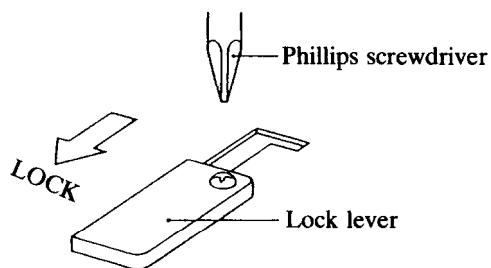

2. Use of batteries

- The remote control transmitter is powered by two batteries. Before using this unit for the first time, insert the two batteries (included).
- Average battery life is about one year. This period may be shorter depending on the frequency of use and environment (temperature and humidity) in which the remote control transmitter is used.

- If the remote control transmitter does not operate even though front panel controls function normally, the batteries should be replaced. Use only listed in the following chart.

Type	Voltage	Size
Manganese	1.5V	AA R6 UM-3

3. Safety check out

After correcting the original service problem, perform the following safety check before releasing the set to the customer:

Connect the insulating-resistance tester between the plug of power supply cable and chassis.

Specifications: more than 10Mohm at 500V.

4. Voltage selector (rear panel)

Worldwide models are equipped with a voltage selector to conform with local power supplies. Be sure to set this selector to match the voltage of the power supply in your area before turning the power switch on. Voltage is changed by turning the voltage selector with a screwdriver or similar instrument to the 120V or 220V position. Confirm that the selector has been set to the correct position before turning the power switch on. If there is no voltage selector switch on the unit you have purchased, it can only be used in areas where the power supply voltage is the same as that of the unit.

LASER WARNING LABEL

The label shown below are affixed.

1. Warning lable

This label is located on the arm of mechanism.

(A)
DANGER —INVISIBLE LASER RADIATION
 WHEN OPEN AND INTERLOCK FAILED OR
 DEFEATED. AVOID DIRECT EXPOSURE TO BEAM
CAUTION —HAZARDOUS LASER AND
 ELECTROMAGNETIC RADIATION WHEN OPEN
 AND INTERLOCK DEFEATED
ATTENTION —RAYONNEMENT LASER
 ET ELECTROMAGNETIQUE DANGEREUX SI
 OUVERT AVEC L'ECLenchEMENT DE SECURITE
 ANNULE.

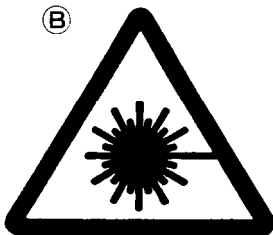

(C)

ADVARSEL: USYNLIG LASERSTRÅLING
 VED ÅBNING, NÅR SIKKERHEDSAF-
 BRYDER ER UDE AF FUNKTION.
 UNDGÅ UDSÆTTELSE FOR STRÅLING.

(D)

VARO! AVATAESSA OLET
 ALLTINA NÄKYMÄTTÖMÄLLE
 LASERSÄTEILYLLE.
 ÄLÄ KATSO SÄTEESEEN.

(E)

VARNING – OSYNLIG
 LASERSTRÅLNING NÄR
 DENNA DEL ÄR ÖPPNAD.
 STRÅLEN ÄR FARLIG.

(A) : Danger label

(B) : Except 120V
 model

(C), (D), (E): Only 230V
 model

2. Certification label (120V model)

This label is located on the back panel.

PRODUCT IS CERTIFIED BY THE MANUFACTURER TO COMPLY
 WITH DHHS RULES 21 CFR SUBCHAPTER J APPLICABLE AT THE
 DATE OF MANUFACTURE.

MANUFACTURED

3. Class 1 label (Except 120V model)

This label is located on the back panel.

“CLASS 1 LASER
 PRODUCT”

ADVARSEL

Denne mærkning er anbragt på apparatets højre side og indikerer, at apparatet arbejder med laserstråler af klasse 1, hvilket betyder, at der anvendes laserstråler af svageste klasse, og at man ikke på apparatets yderside kan blive udsat for utilladelig kraftig stråling.

APPARATET BØR KUN ÅBNES AF FAGFOLK MED SÆRLIGT
 KENDSKAB TIL APPARATER MED LASERSTRÅLER!

Indvendigt i apparatet er anbragt den her gengivne advarselmærkning, som advarer imod at foretage sådanne indgreb i apparatet, at man kan komme til at udsætte sig for laserstråling.

VAROITUS! Laite sisältää laserdiodin, joka lähettää (näkymä-
 töntä) silmille vaarallista lasersäteilyä.

CHASSIS-EXPLODED VIEW

MODEL DX-706

DX-706

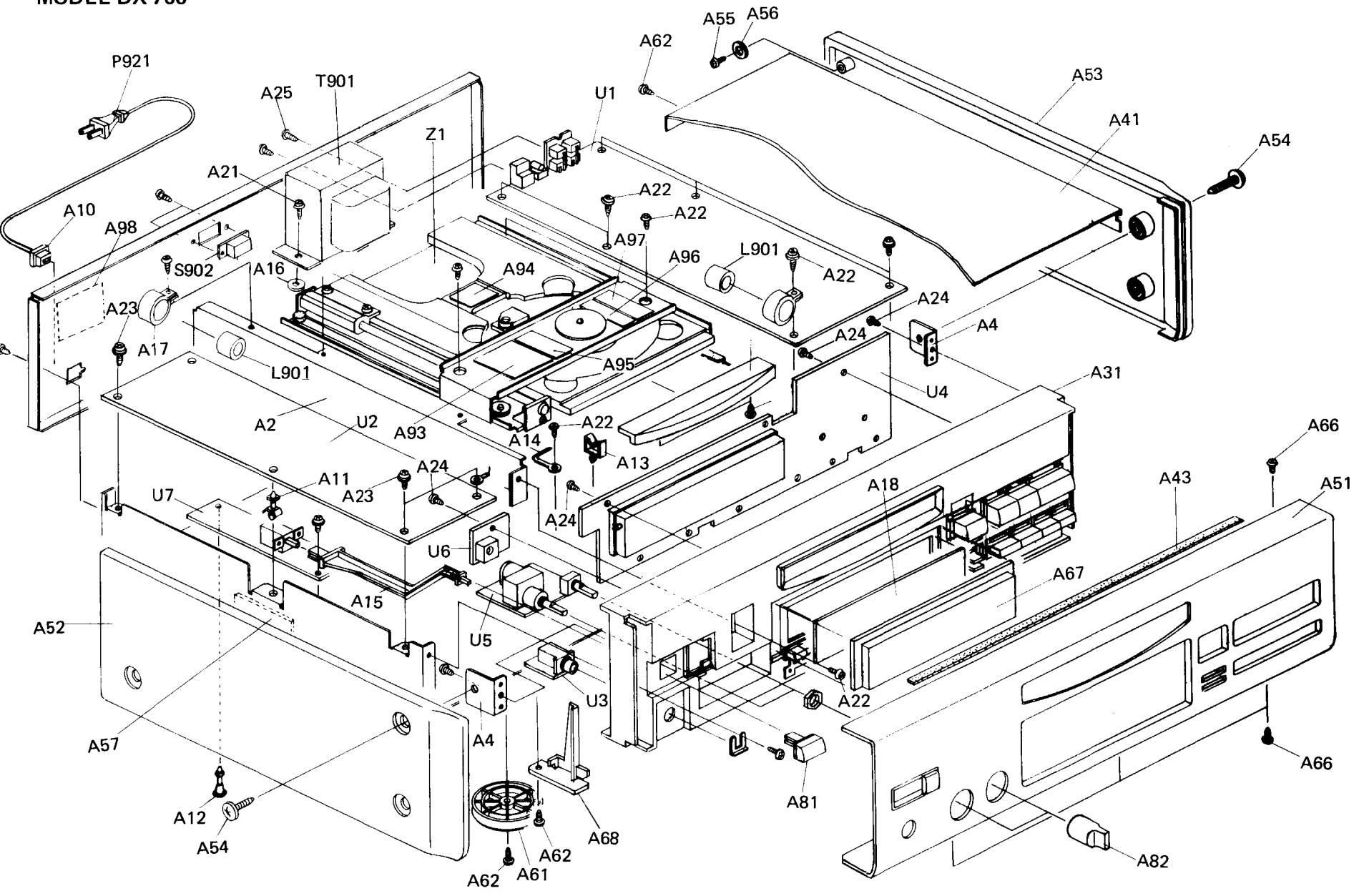

PARTS LIST

MODEL DX-706

REF.NO.	PART NO.	DESCRIPTION	REF.NO.	PART NO.	DESCRIPTION
A1	27100248A	Chassis	A95	29360811A	Label <P>
A2	27130660B	Bracket C	A96	29361298	Label SEM <P>
A4	27141496	Bracket S	A97	29361342	Label SEM/FIN <P>
A8	27121503	Back panel <D>	A98	29360687	Label CLASS1 <P/W/Q>
	27121504	Back panel <P>	A99	28175189	Insulator plate <S>
	27121506	Back panel <W>	L901	230910	ESD-R-25DB,Core
	27121511	Back panel <Q>	P921	253161,	▲ AS-UC-6#18,
A10	27300750	▲ Bushing,cord		253168 or	Power supply cord
A11	27190009	KGLS-4S,Holder		253146	<D>
A12	27190524	KGLS-14R,Holder		253149	▲ AS-CEE 250V 2.5A,
A13	27300833	Clamp			Power supply cord <P/W>
A14	27255004	Clip		253170	▲ AS-SAA,Power supply cord <Q>
A15	27273142	Joint, power	S902	25065195	▲ NSS-1288P,Voltage selector switch <W>
A16	27270327A	Spacer	T901	2300727A	▲ NPT-1121D,Power transformer <D>
A17	27190608	Holder,clamp		2300728A	▲ NPT-1121P,Power transformer <P>
A18	28133269	Back plate		2300729A	▲ NPT-1121DG,Power transformer <W>
A21	830440109	4TTC+10C(BC),Self-tapping screw		2300734A	▲ NPT-1121Q,Power transformer <Q>
A22	834430088	3TTS+8B(BC),Self-tapping screw	U1	1H169572-1	NAAR-4272-1,Main circuit pc board ass'y
A23	831130088	3TTW+8B,Self-tapping screw	U2	1H169573-1	NADG-4273-1,Digital circuit pc board ass'y <D>
A24	833430080	3TTP+8P(BC),Self-tapping screw		1H169573-1A	NADG-4273-1A,Digital circuit pc board ass'y <P/W/Q>
A25	801230	3STS+8BQ(BC),Self-tapping screw	U3	1H169574-1	NAAF-4274-1,Headphone terminal pc board ass'y
A31	27110659B	Front bracket ass'y 	U4	1H169575-1	NADIS-4275-1,Display circuit pc board ass'y <D>
	27110660A	Front bracket ass'y <S>		1H169575-1A	NADIS-4275-1A,Display circuit pc board ass'y <P/W/Q>
A41	28184490A	Top cover	U5	1H169576-1	NAAF-4276-1,Output volume pc board ass'y
A43	28140837	0.9×250×10mm,Cushion	U6	1H169577-1	NAETC-4277-1,Sensor pc board ass'y
A44	28141009	1.5×195×125mm,Cushion	U7	1H169578-1	NAPS-4278-1,Power supply pc board ass'y
A51	1H169121	Front panel ass'y 	Z1		NCD-39M,Mechanism ass'y
	1H170121	Front panel ass'y <S>		260208	Binder
A52	28185371	Side panel L			
A53	28185372	Side panel R			
A54	837440169	4TTC+16C(BC),Self-tapping screw			
A55	834440088	4TTS+8B(BC),Self-tapping screw			
A56	87644012	W4×12F(BC),Washer			
A57	28175190	Insulator plate			
A61	27175254	Leg			
A62	834430088	3TTS+8B(BC),Self-tapping screw			
A64	28148256	Tray panel 			
	28148258	Tray panel <S>			
A65	838430068	3TTB+6B(BC),Self-tapping screw			
A66	833430080	3TTP+8P(BC),Self-tapping screw			
A67	28191604A	Clear plate			
A68	28335034A	Lever, lock			
A81	28324397	Knob, power 			
	28324398	Knob, power <S>			
A82	28324492	Knob, level 			
	28324493	Knob, level <S>			
A93	29360807	Label DANGER			
A94	29361218	Label LASER <P/W/Q>			

NOTE: <D>:Only 120V model
 <P>:Only 230V model
 <W>:Only Worldwide model
 <Q>:Only 240V model
 :Only Black model
 <S>:Only Silver model

NOTE: THE COMPONENTS IDENTIFIED BY MARK ▲
 ARE CRITICAL FOR RISK OF FIRE AND
 ELECTRIC SHOCK. REPLACE ONLY WITH
 PART NUMBER SPECIFIED.

CHASSIS-EXPLODED VIEW

MODEL DX-708

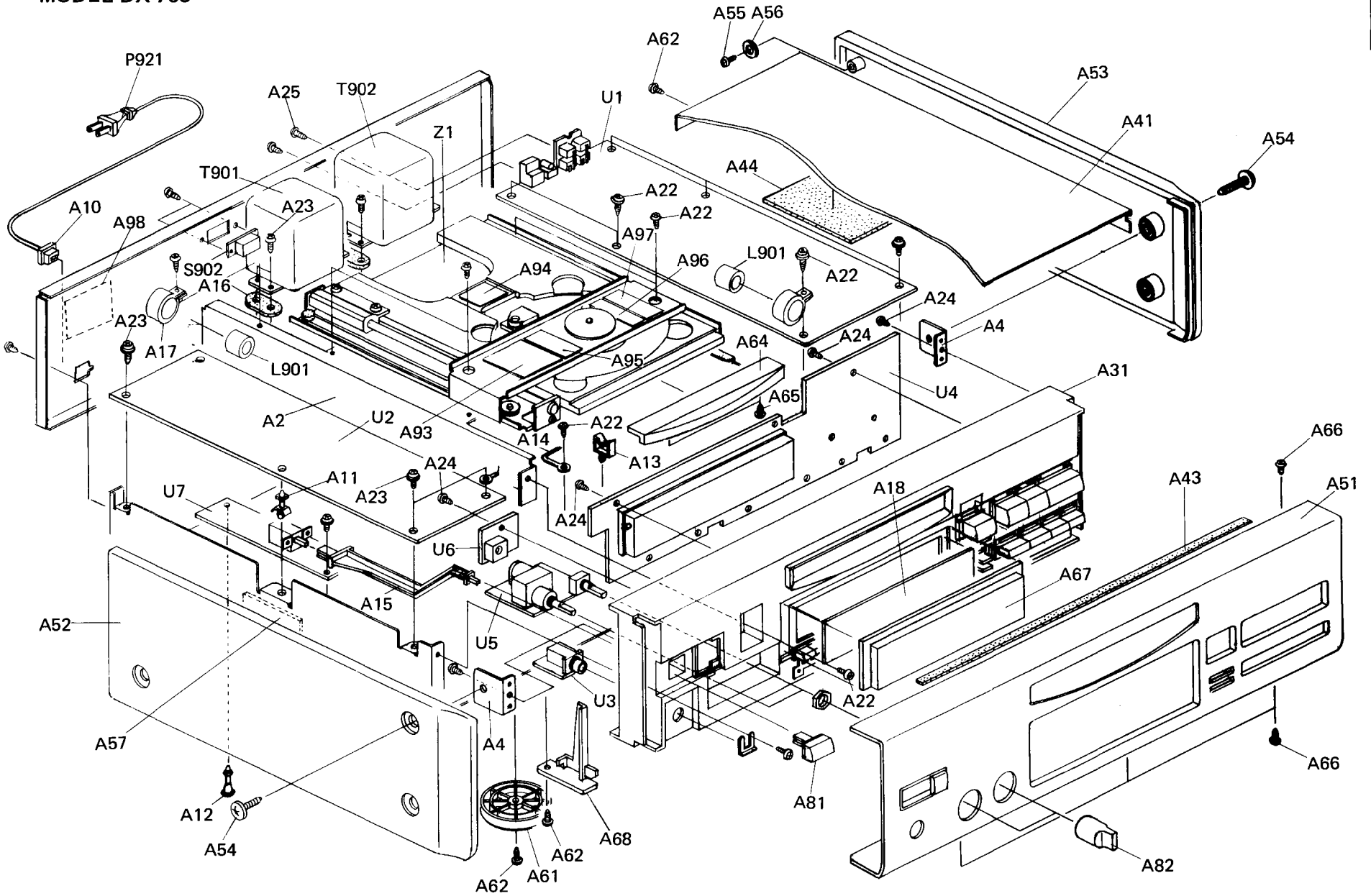

PARTS LIST

MODEL DX-708

REF.NO.	PART NO.	DESCRIPTION
A1	27100249A	Chassis
A2	27130661A	Bracket C
A4	27141496	Bracket S
A8	27121507	Back panel <D>
	27121508	Back panel <P>
	27121510	Back panel <W>
	27121512	Back panel <Q>
A10	27300750	△ Bushing, cord
A11	27190009	KGLS-4S, Holder
A12	27190524	KGLS-14R, Holder
A13	27300833	Clamp
A14	27255004	Clip
A15	27273142	Joint, power
A16	27270327A	Spacer
A17	27190608	Holder, clamp
A18	28133269	Back plate
A21	838440109	4TTB+10C(BC), Self-tapping screw
A22	834430088	3TTS+8B(BC), Self-tapping screw
A23	831130088	3TTW+8B, Self-tapping screw
A24	833430080	3TTP+8P(BC), Self-tapping screw
A25	801230	3STS+8BQ(BC), Self-tapping screw
A31	27110659B	Front bracket ass'y
A41	28184490A	Top cover
A43	28140837	0.9×250×10mm, Cushion
A44	28141009	1.5×195×125mm, Cushion
A51	<u>1H173121</u>	Front panel ass'y
A52	<u>28185371</u>	Side panel L
A53	<u>28185372</u>	Side panel R
A54	837440169	4TTC+16C(BC), Self-tapping screw
A55	834440088	4TTS+8B(BC), Self-tapping screw
A56	87644012	W4×12F(BC), Washer
A57	28175190	Insulator plate
A61	27175254	Leg
A62	834430088	3TTS+8B(BC), Self-tapping screw
A64	28148256	Tray panel
A65	838430068	3TTB+6B(BC), Self-tapping screw
A66	833430080	3TTP+8P(BC), Self-tapping screw
A67	28191604A	Clear plate
A68	28335034A	Lever, lock
A81	28324397	Knob, power
A82	28324492	Knob, level
A93	29360807	Label DANGER
A94	29361218	Label LASER <P/W/Q>
A95	29360811A	Label <P>
A96	29361298	Label SEM <P>
A97	29361342	Label SEM/FIN <P>
A98	29360687	Label CLASS1 <P/W/Q>
L901	230910	ESD-R-25DB, Core

REF.NO.	PART NO.	DESCRIPTION
P921	253161, 253168 or 253146 253149	△ AS-UC-6#18, Power supply cord <D> △ AS-CEE 250V 2.5A, Power supply cord <P/W>
S902	253170	△ AS-SAA, Power supply cord <Q>
T901	25065195 2300735 2300736 2300737 2300738	△ NSS-1288P, Voltage selector switch <W> △ NPT-1123D, Power transformer <D> △ NPT-1123P, Power transformer <P> △ NPT-1123DG, Power transformer <W> △ NPT-1123Q, Power transformer <Q>
T902	2300739 2300740 2300741 2300742	△ NPT-1124D, Power transformer <D> △ NPT-1124P, Power transformer <P> △ NPT-1124DG, Power transformer <W> △ NPT-1124Q, Power transformer <Q>
U1	1H173572-2	NAAR-4272-2, Main circuit pc board ass'y
U2	1H173573-2 1H173573-2A	NADG-4273-2, Digital circuit pc board ass'y <D> NADG-4273-2A, Digital circuit pc board ass'y <P/W/Q>
U3	1H173574-2	NAAF-4274-2, Headphone terminal pc board ass'y
U4	1H173575-2 1H173575-2 1H173575-2A	NADIS-4275-2, Display circuit pc board ass'y <D> NADIS-4275-2A, Display circuit pc board ass'y <P/W/Q>
U5	1H173576-2	NAAF-4276-2, Output volume pc board ass'y
U6	1H173577-2	NAETC-4277-2, Sensor pc board ass'y
U7	1H173578-2	NAPS-4278-2, Power supply pc board ass'y
Z1	260208	NCD-39M, Mechanism ass'y Binder

NOTE: <D>: Only 120V model
<P>: Only 230V model
<W>: Only Worldwide model
<Q>: Only 240V model

NOTE: THE COMPONENTS IDENTIFIED BY MARK △
ARE CRITICAL FOR RISK OF FIRE AND
ELECTRIC SHOCK. REPLACE ONLY WITH
PART NUMBER SPECIFIED.

MECHANISM EXPLODED VIEW

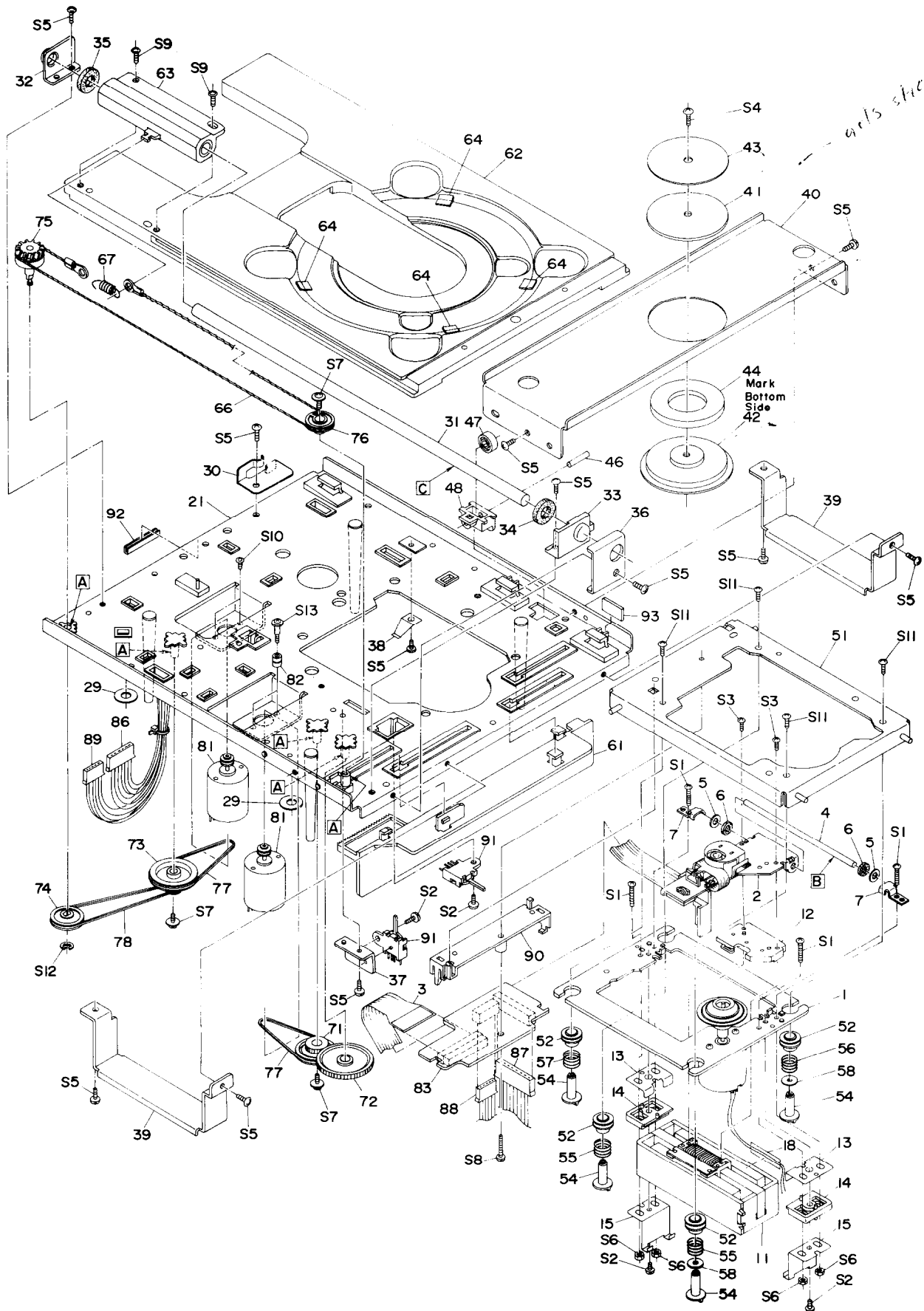

PARTS LIST

REF.NO.	PART NO.	DESCRIPTION	REF.NO.	PART NO.	DESCRIPTION
1	27100219A	Chassis ass'y,pickup	89	2009990199	NSAS-5P0281,Socket
2	24110007A	SPU-3011,Optical pickup	90	27190775	Holder
3	25134076	NCETC-4076,Flake pc board	91	25065422	NMS-1220,Microswitch
4	24506955	Shaft	92	28170024	Bushing
5	27270322	Spacer	93	27270342	Spacer,guide
6	27270323	Spacer	S1	82112010	2P+10F,Pan head screw
7	24506952	Bracket,shaft	S2	838426088	2.6TTB+8B(BC),Self-tapping screw
11	24502261	SLA2002,Motor,slide	S3	838120080	2TTB+8P,Self-tapping screw
12	24506950	Block,terminal	S4	833426050	2.6TTP+5P(BC),Self-tapping screw
13	24506953	Bracket LM	S5	834430068	3TTS+6B(BC),Self-tapping screw
14	24506951	Base LM	S6	863120	N-2F,Nut
15	24506954	Holder LM	S7	831126060	2.6TTW+6P(BC),Self-tapping screw
18	28141068	Cushion	S8	833326148	2.6TTP+14B,Self-tapping screw
21	27301335D	Chassis L	S9	834430088	3TTS+8B(BC),Self-tapping screw
29	27270212	Spacer	S10	82143004	3P+4FN(BC),Pan head screw
30	27180467	Plate spring	S11	838120080	2TTB+8P,Self-tapping screw
31	27260297A	Shaft,guide	S12	8930251S	ES-2.5S, Ring E
32	27141408	Bracket,shaft	S13	801470	Special screw
33	27301342	Shaft,base	S14	838426088	2.6TTB+8B(BC),Self-tapping screw
34	27270324	Spacer			
35	27270325A	Spacer			
36	27141438	Bracket,base			
37	27141409	Bracket,switch			
38	27180460	Spring			
39	27141440A	Bracket H			
40	27301343	Arm			
41	28141061A	Cushion CH ←			
42	27301352	Cap CH			
43	27301344	Yoke CH ←			
44	28181019A	Magnet CH ←			
46	27260308	Shaft RO			
47	27301465A	Roller			
48	27190861A	Holder RO			
51	27301345A	Chassis,sub			
52	27301466A	Cushion rubber			
54	27301347A	Spacer,floating			
55	27180461	Spring,silver			
56	27180462	Spring,green			
57	27180463	Spring,yellow			
58	27270330	Spacer			
61	27301349B	Cam plate			
62	27301331-1	Disc tray			
63	27301333B	Guide,bearing			
64	28141081	Cushion,tray			
66	27301391	Rope			
67	27180464	Spring,wire			
71	27301336	Pulley,gear			
72	27301337	Flat wheel			
73	27301338	Middle pulley			
74	27301339	Pulley			
75	27301389	Drive pulley			
76	27301341	Flat pulley			
77	27301350	Rubber belt S			
78	27301351	Rubber belt L			
81	1H048902	Motor ass'y			
82	27301468	Bush,motor			
83	1H169537-2	NAETC-3937-2,Terminal pc board ass'y			
86	2009990098A	NSAS-6P0137,Socket			
87	2009990099B	NSAS-18P0138,Socket			
88	2002391445	NSAS-14P0260,Socket			

TERMINAL PC BOARD-PARTS LIST

CIRCUIT NO.	PART NO.	DESCRIPTION
P001	25050428	NSCT-18P,Socket
P103A	25055139	NPLG-9P123,Plug
P108A	25055151	NPLG-7P135,Plug

LUBRICATION

POINT	PART NO.	DESCRIPTION
A	260447	G902S
B	260451	#331
C		G947P

CAUTION ON REPLACEMENT OF PICKUP

The laser diode in the optical pickup block is so sensitive to static electricity, surge current and etc. that the components are liable to be broken down or its reliability remarkably deteriorated.

During repair, carefully take the following precautions. (The following precautions are included in the service parts).

PRECAUTIONS

1. Ground for the work-desk.

Place a conductive sheet such as a sheet of copper (with impedance lower than $10^6 \Omega$) on the work-desk and place the set on the conductive sheet so that the chassis.

2. Grounding for the test equipment and tools.

Test equipments and toolings should be grounded in order that their ground level is the same the ground of the power source.

3. Grounding for the human body.

Be sure to put on a wrist-strap for grounding whose other end is grounded.

Be particularly careful when the workers wear synthetic fiber clothes, or air is dry.

4. Select a soldering iron that permits no leakage and have the tip of the iron well-grounded.

5. Do not check the laser diode terminals with the probe of a circuit tester or oscilloscope.

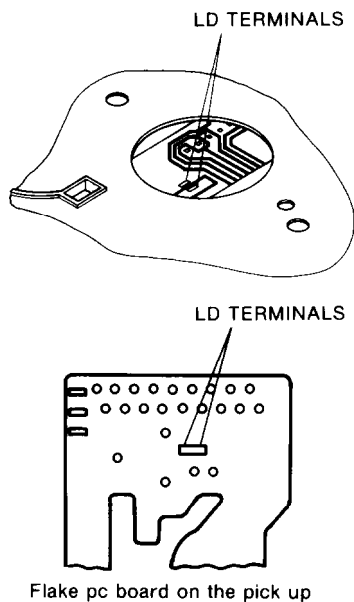

(Care should be taken with the optical pickup.)

The optical pickup is sensitive to static electricity, surge currents, and other high electrical noise, and because there is the possibility of damage to performance, in the handling of the pickup, the utmost care must be taken, particularly with regard to static electricity.

Mechanism ass'y removal

When remove the mechanism ass'y, first short the LD terminals on the pc board and remove the mechanism ass'y.

Optical pickup removal

1. When replacing the optical pickup, first short the LD terminals and remove the connector. Also, when attaching the new optical pickup, after attaching the connector, unsolder the LD terminals.
2. Do not touch the optical pickup object lens with the hands.

PROTECTION OF EYES FROM LASER BEAM DURING SERVICING

This unit employs a laser. Therefore, be sure to follow carefully the instructions below when servicing.

WARNING!!

WHEN SERVICING, DO NOT APPROACH THE LASER EXIT WITH THE EYE TOO CLOSELY. IN CASE IT IS NECESSARY TO CONFIRM LASER BEAM EMISSION, BE SURE TO OBSERVE FROM A DISTANCE OF MORE THAN 30cm FROM THE SURFACE OF THE OBJECTIVE LENS ON THE OPTICAL PICKUP BLOCK.

Laser Diode Properties

- Material: GaAs/GaAlAs
- Wavelength: 780nm
- Emission Duration: Continuous
- Laser output: Max. 0.5mW*

*This output is the value measured at a distance about 1.8mm from the objective lens surface on the optical pickup block.

IC BLOCK DIAGRAM AND DESCRIPTIONS

CXA1571S (RF Amplifier)

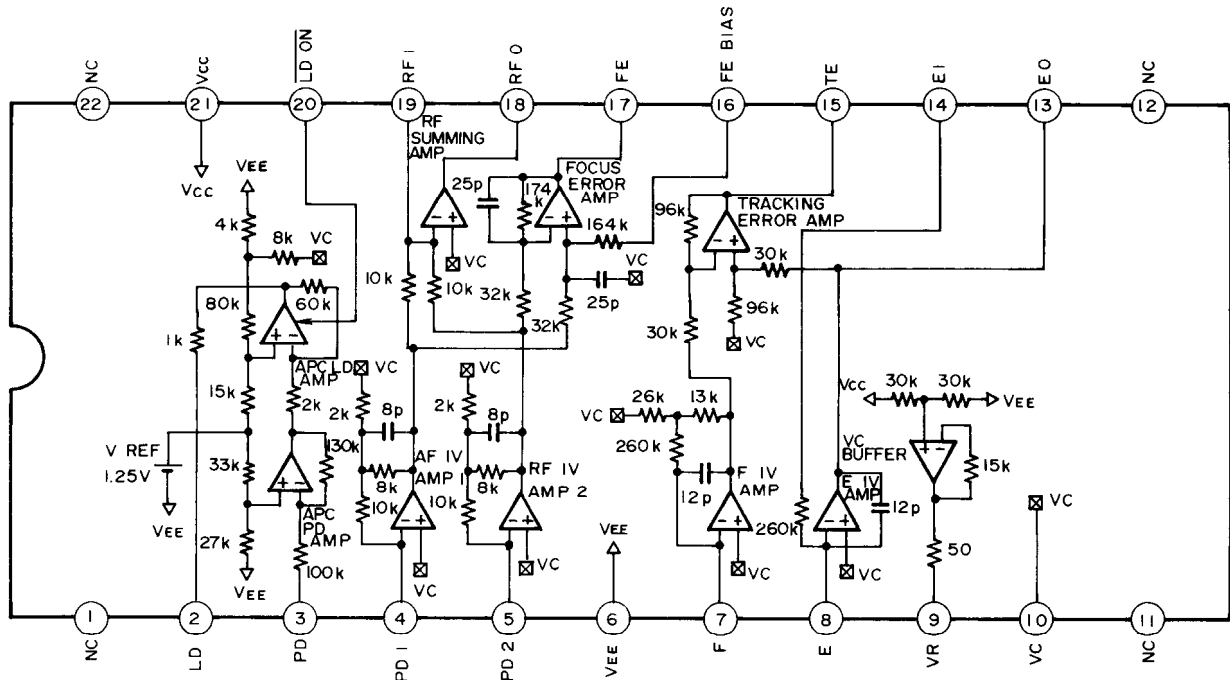

Pin No.	Symbol	I/O	Description
2	LD	O	Output terminal of APC amplifier.
3	PD	I	Input terminal of APC amplifier.
4	PD1	I	Inversion input terminal for RF I-V amplifier. Connect to photo diode A+C.
5	PD2	I	Inversion input terminal for RF I-V amplifier. Connect to photo diode B+D.
7	F-IN	I	Inversion input terminal for F I-V amplifier. Connect to photo diode F.
8	E-IN	I	Inversion input terminal for E I-V amplifier. Connect to photo diode E.
9	VR	O	DC voltage output of $(V_{CC} + V_{EE})/2$.
10	VC	I	Middle point voltage input terminal.
13	EO	O	Monitor output terminal for I-V amplifier E.
14	EI	-	Gain adjustment terminal for I-V amplifier E.
15	TE	O	Tracking error amplifier output terminal. The signal E-F is output from this terminal.
16	FE-BIAS	I	Bias adjustment terminal for non-inversion side of focus error amplifier.
17	FE	O	Focus error amplifier output terminal.
18	RFO	O	RF amplifier output terminal.
19	RFI	I	Inversion input terminal of RF amplifier.
20	LD-ON	I	Change-over terminal for APC amplifier.

CXA1372S (RF Signal Processor Servo Amplifier)

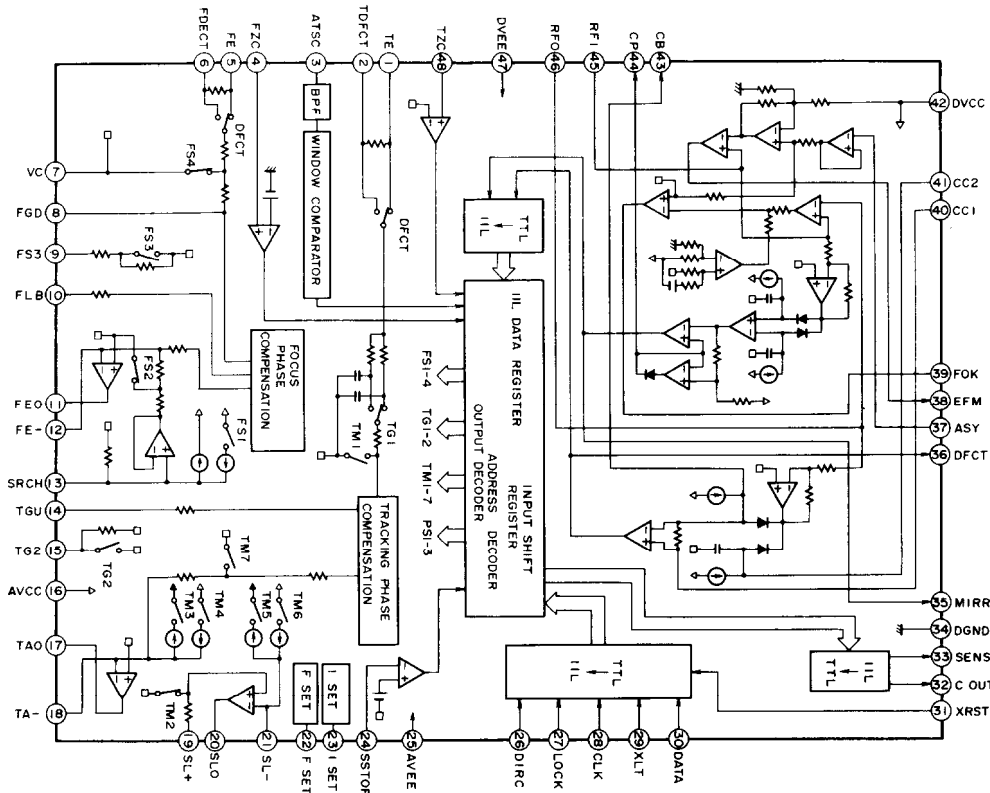

PIN. NO.	SYMBOL	I/O	DESCRIPTION	PIN. NO.	SYMBOL	I/O	DESCRIPTION
1	TE	I	Tracking error input terminal.	22	FSET	I	Peak setting input of phase correction of focus tracking.
2	TDFCT	I	Capacitor connection terminal for time constant when defect.	23	ISET	I	This terminal is flowed the current so that the focus search, tracking jump, and sled kick height is decided.
3	ATSC	I	Window comparator input terminal for ATSC detection.	24	SSTOP	I	Inner switch selection input terminal.
4	FZC	I	Focus zero-cross comparator input terminal.	26	DIRC	I	This terminal is used when a track jump.
5	FE	I	Focus error input terminal.	27	LOCK	I	The sled runaway prevention circuit operates at the low level.
6	DFDCT	I	Capacitor connection terminal for time constant when defect.	28	CLK	I	Serial data transfer clock input from microprocessor.
7	VC	I	Mid-point voltage input terminal.	29	XLT	I	Latch input from microprocessor.
8	FGD	I	Connect the capacitor between pin 9 and this pin when the high frequency gain of focus servo is dropped.	30	DATA	I	Serial data input from microprocessor.
9	FS3	I	Focus servo high frequency gain changeover input terminal.	31	XRST	I	Reset input terminal. Active low.
10	FLB	I	Input terminal for the low frequency boost of focus servo.	32	C. OUT	O	Signal output to count the track numbers.
11	FEO	O	Focus drive output terminal.	33	SENS	O	This terminal outputs FZC. and SSTOP to according command from microprocessor.
12	FE-	I	Inversion input terminal of focus amplifier.	35	MIRR	O	Mirror comparator output terminal.
13	SRCH	I	Time constant terminal to make the focus search waveform.	36	DFCT	O	Defect comparator output terminal.
14	TGU	I	Tracking high frequency gain changeover input terminal.	37	ASY	I	Auto asymmetry control input terminal.
15	TG2	I	Tracking high frequency changeover input terminal.	38	EFM	O	EFM comparator output terminal.
17	TAO	O	Tracking drive output terminal.	39	FOK	O	Focus OK comparator output terminal.
18	TA-	I	Inversion input terminal of tracking amplifier.	40	CC1	O	Defect bottom hold output terminal.
19	SL+	I	No-inversion input terminal of sled amplifier.	41	CC2	I	Defect bottom hold input terminal from CC1.
20	SLO	O	Sled (slide) drive output terminal.	43	CB	I	Defect bottom hold capacitor connection terminal.
21	SL-	I	Inversion input terminal of sled amplifier.	44	CP	I	Mirror hold capacitor connection terminal.
				45	RFI	I	RF summing amplifier input terminal.
				46	RFO	O	RF summing amplifier output terminal.
				48	TZC	I	Tracking zero-cross comparator input terminal.

SM5813AP (18 bits Oversampling Digital Filter)

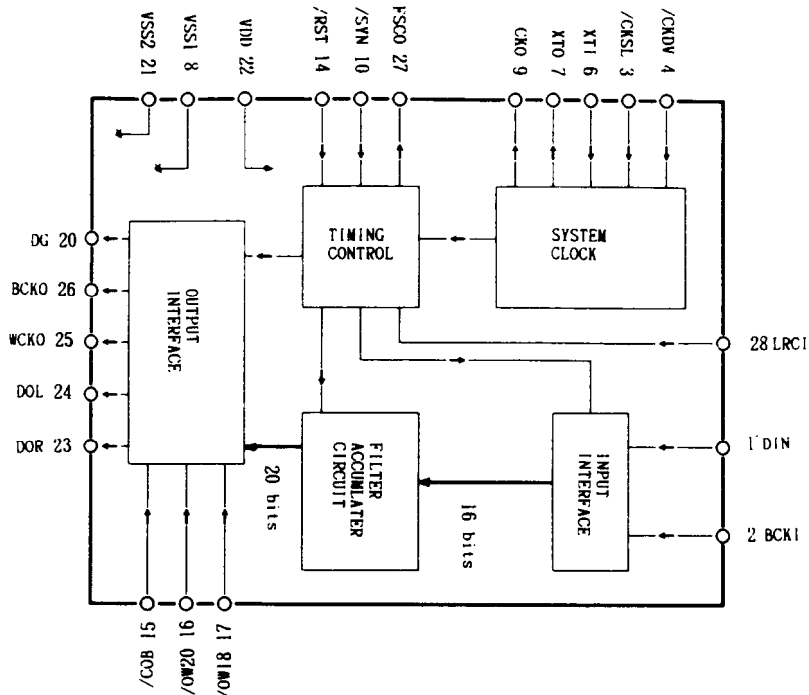

Pin No.	Terminal	I/O	Function
1	DIN	I	Input data
2	BCKI	I	Bit clock of input data
3	/CKSL	I	Input frequency selection terminals of terminal XTI (Pin 6)
4	/CKVD	I	
6	XTI	I	Input section of oscillator section
7	XTO	O	Output section of oscillator section
8	Vss1		Ground terminal
9	CKO	O	Output clock of oscillator section The frequency is same as XTI
10	/SYN	I	Mode selection terminal H:Jitter free L:Forced sync.
14	/RST	I	System reset H:Normal L:Reset
15	/COB	I	H:Complement of 2 L:COB
16	/OW20	I	Output bit numbers selector
17	/OW18	I	
20	DG	O	Degilith control clock
21	Vss2		Ground terminal
22	VDD		Power supply terminal (+5V)
23	DOR	O	8-times oversampling output data of right channel
24	DOL	O	8-times oversampling output data of left channel
25	WCKO	O	Word clock of output data
26	BCKO	O	Bit clock of output data
27	FSCO	O	Internal accumulator timing clock of period fs.
28	LRCI	I	Sample rate clock of input data

Output bit numbers

Output bit	16	18	20
/OW18	H	L	H
/OW20	H	H	L

SM5861AP (D/A converter)

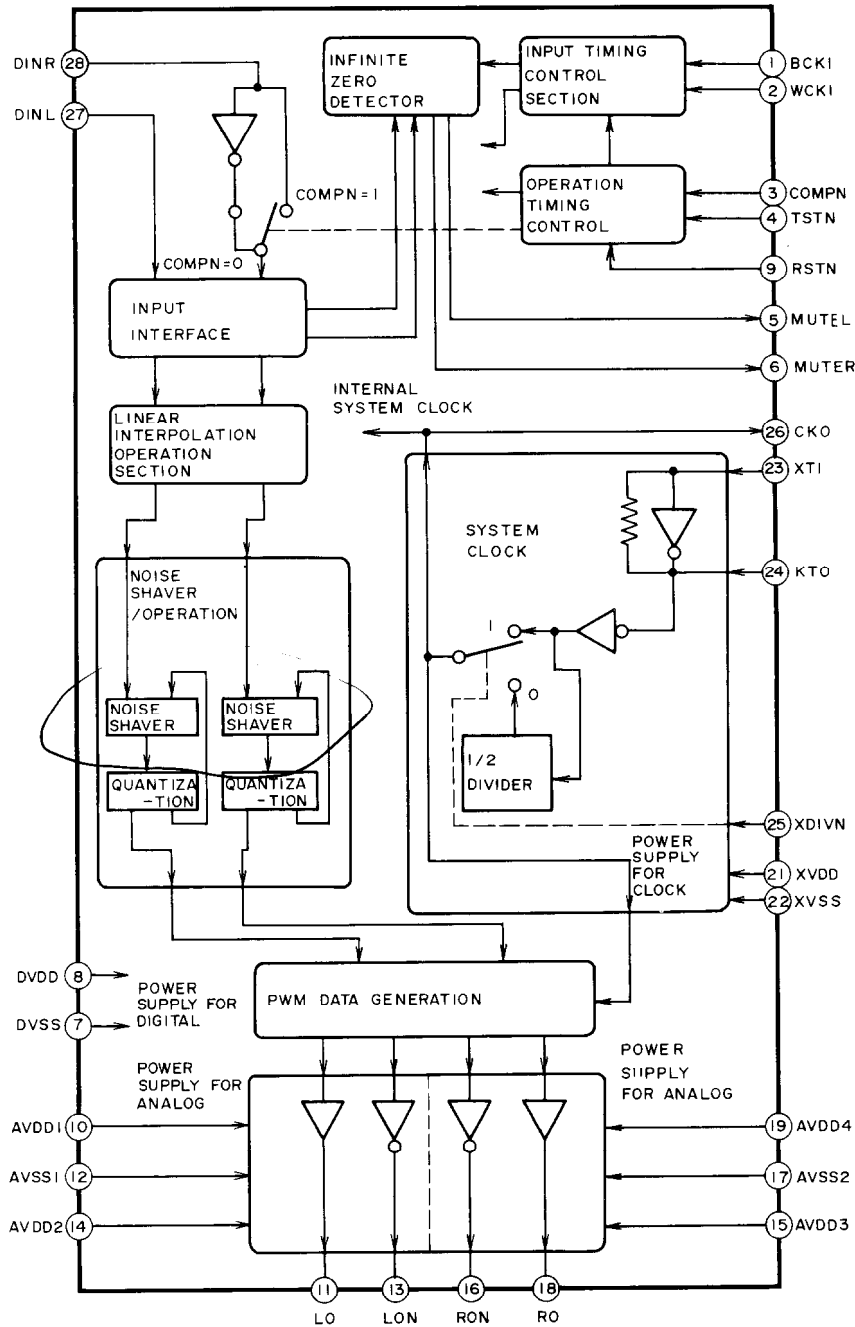

Pin No.	Symbol	Description	Pin No.	Symbol	Description
1	BCKI	Serial input data bit clock	15	AVDD3	5V supply for analogue section
2	WCKI	Input data word clock	16	RON	Data output
3	COMPN	Mode select of PWM output	17	AVSS2	Ground for analogue section
4	TSTN	Test terminal	18	RO	Data output
5	MUTEL	Muting output for left channel	19	AVDD4	Ground for analogue section
6	MUTER	Muting output for right channel	20	NC	
7	DVSS	Ground for digital section	21	XVDD	5V supply for clock section
8	DVDD	5V power supply for digital section	22	XVSS	Ground for clock section
9	RSTN	Reset input	23	XTI	Crystal oscillator input
10	AVDD1	5V supply for analogue section	24	XTO	Crystal oscillator output
11	LO	Data output	25	XDIVN	System clock select
12	AVSS1	Ground for analogue section	26	CKO	Clock output
13	LON	Data output	27	DINL	Serial data input for left channel
14	AVDD2	5V supply for analogue section	28	DINR	Serial data input for right channel

CXD2500AQ (Digital Signal Processor)

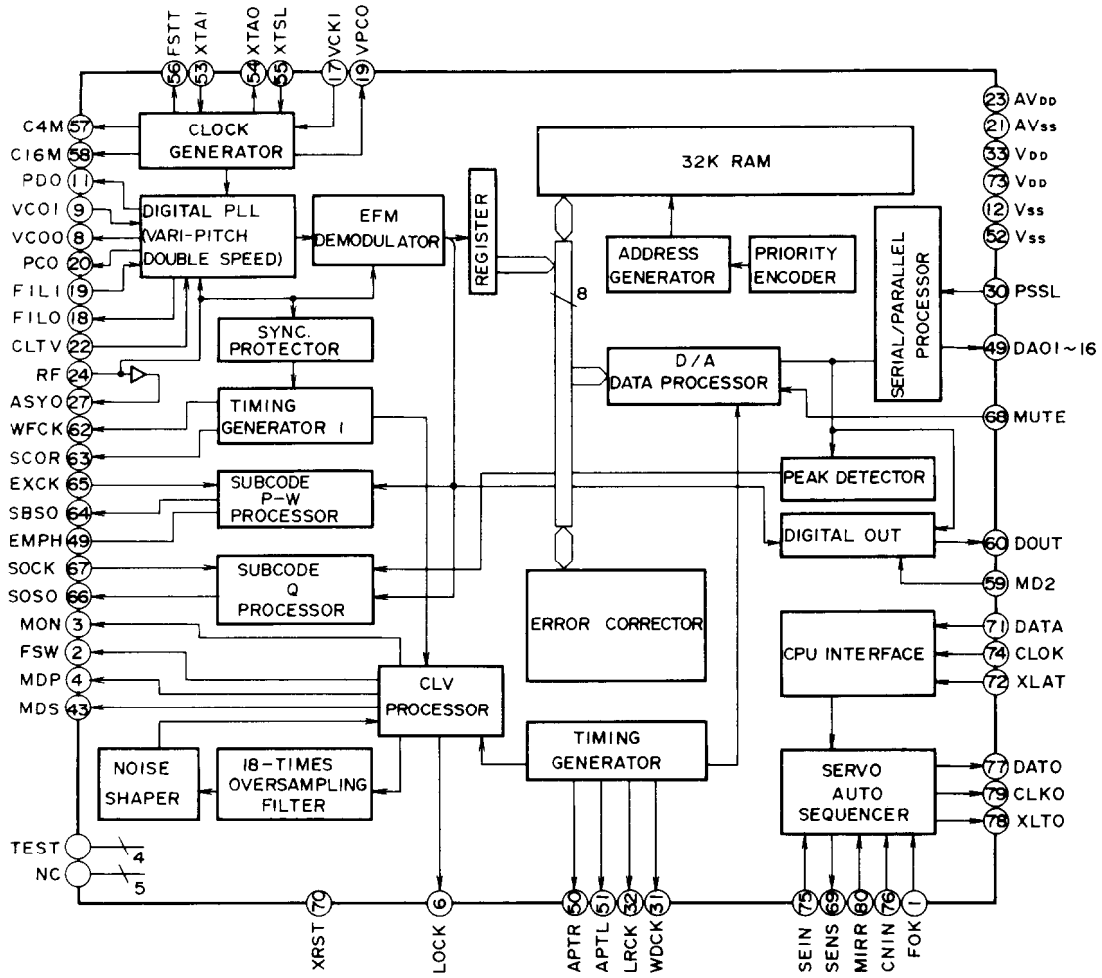

LB1630 (Volume Motor Drive)

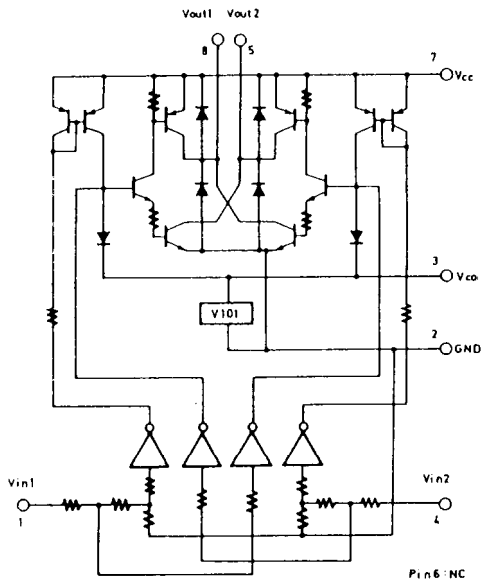

NO.	SYMBOL	I/O	DESCRIPTION	NO.	SYMBOL	I/O	DESCRIPTION
1	FOK	I	Focus OK input	42	DA08	O	DA08 GFS output
2	FSW	O	Output filter changeover output of spindle motor	43	DA07	O	DA07 RFCK output
3	MON	O	Spindle motor control output	44	DA06	O	DA06 C2P0 output
4	MDP	O	Spindle motor servo control	45	DA05	O	DA05 XRAOF output
5	MDS	O	Spindle motor servo control	46	DA04	O	DA04 MNT3 output
6	LOCK	O	H when GFS is high	47	DA03	O	DA03 MNT2 output
7	NC			48	DA02	O	DA02 MNT1 output
8	VCOO	O	Oscillation circuit output for analog FEM PLL	49	DA01	O	DA01 MNT0 output
9	VCOI	I	Oscillation circuit input for analog EFM PLL (8.6436MHz)	50	APTR	O	Control output for aperture correction. H when Rch.
10	TEST	I	Test terminal	51	APTL	O	Control output for aperture correction. H when Lch.
11	PDO	O	Charge pump output for analog EFM PLL	52	Vss		Ground
12	Vss		Ground terminal	53	XTAI	I	Crystal oscillation circuit input of 16.9344MHz or 33.8688MHz input
13-15	NC			54	XTAO	O	Crystal oscillation circuit output of 16.9344MHz
16	VPCO	O	PLL charge pump output for variable pitch	55	XTSL	I	Crystal selection input terminal. L when 16.9344MHz. H when 33.8688MHz.
17	VCKI	I	Clock input for variable pitch from VCO (16.934MHz)	56	FSTT	O	2/3 divided output of pins 53 & 54
18	FILO	O	Filter output for master PLL	57	C4M	O	4.2336MHz output
19	FILI	I	Filter input for master PLL	58	C16M	O	16.9344MHz output
20	PCO	O	Charge pump output for master PLL	59	MD2	I	Digital output control input. On at H & Off at L.
21	AVss		Analog ground	60	DOUT	O	Digital output
22	CLTV	I	VCO control voltage input for master	61	EMPH	O	Emphasis control output. Active H.
23	AVDD		Analog section power supply(+5V)	62	WFCK	O	Write frame clock output
24	RF	I	EFM signal input	63	SCOR	O	Sub-code detection output. H when is detected S0 or S1.
25	TEST2	I	Connect to the ground.	64	SBSO	O	Serial output of sub code (P~W)
26	TEST3	I	Connect to the ground.	65	EXCK	I	Clock input for read out SBSO
27	ASYO	O	EFM full swing output	66	SQSO	O	Sub Q 80 bits, PCM peak, and level data 16 bits output
28	TEST4	I	Connect to the ground.	67	SQCK	I	Clock input for read out SQSO
29	NC			68	MUTE	O	Muting control output. Active H.
30	PSSL	I	Audio data output mode changeover input. Serial data at L and parallel data at H.	69	SENS	-	Sens output. Output to microprocessor
31	WDCK	O	D/A interface for 48 bits slot. Word clock f=2Fs.	70	XRST	I	System reset. Rest at low level.
32	LRCK	O	D/A interface for 48 bits slot. LR clock f=Fs.	70	DATA	I	Serial data input from microprocessor
33	VDD		Power supply terminal(+5V)	72	XLTA	I	Latch input from microprocessor. Latch the serial data at trailing.
34-49			Data output terminals	73	VDD		Power supply
			PSSL=1 PSSL=0	74	CLOK	I	Serial data transfer clock input from microprocessor
34	DA16	O	DA16 Serial data of 48 bits slot	75	SEIN	I	Sens input from SSP
35	DA15	O	DA15 Bit clock of 48 bits slot	76	CNCI	I	Track jump numbers count signal input
36	DA14	O	DA14 Serial data of 64 bits slot	77	DATO	O	Serial data output to SSP
37	DA13	O	DA13 Bit clock of 68 bits slot	78	XLTO	O	Serial data latch output to SSP. Latch at trailing.
38	DA12	O	DA12 LR clock of 68 bits slot	79	CLKO	O	Serial data transfer clock output to SSP
39	DA11	O	DA11 GTOP output	80	MIRR	I	Mirror signal input
40	DA10	O	DA10 XUGF output				
41	DA09	O	DA09 XPLCK output				

Note:SSP:Q104 CXA1372S

CXP50116-166 (Microprocessor)

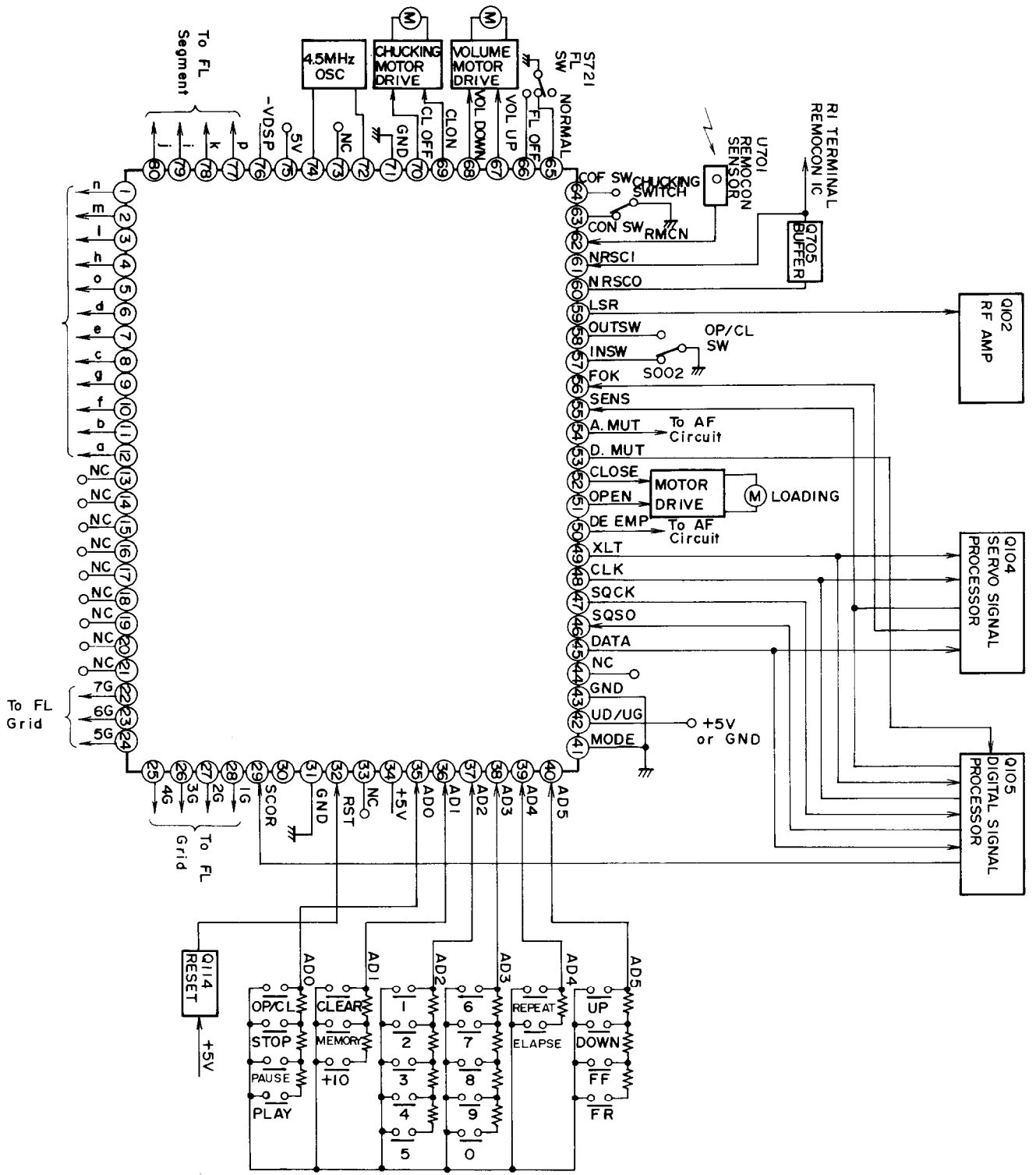

Pin No.	Symbol	I/O	Descriptions
1~12	n, m, l, h, o, d e, c, g, t, b, a	O	Fluorescent indicator tube segment output terminals. Active high.
22~28	7G~1G	O	Fluorescent indicator tube grid output terminals. Active high.
29	SCOR	I	Sub code sink input terminal. Leading pulse (75Hz) is input during play.
32	XRST	I/O	Reset input terminal. Reset at low level when the power switch turns on.
34	VDD		+5V power supply.
35~40	AD0~AD5	I	A/D converter input terminals for key input.
42	UD/UG	I	Indicator method changeover input when the power switch turns on.
44	SC	O	Servo system serial command clock (CLK) and sub code Q read clock (SQCK) output terminal.
45	DATA	O	Data output terminal of serial command of servo system.
46	SQSO	I	Input terminal of sub code Q.
47	SQCK	O	Read clock output control terminal of sub code Q.
48	CLK	O	Clock output control terminal of serial command of servo system.
49	XLT	O	Latch command output terminal of serial command of servo system.
50	DEEMP	O	Emphasis switch control output terminal. Active high.
51	OPEN	O	Tray open operation output terminal. Open at low level.
52	CLOSE	O	Tray close operation output terminal. Close at low level.
53	D. MUT	O	Digital muting control output terminal.
54	A. MUT	O	Audio muting control output terminal. Muting turns off at low level.
55	SENSE	I	This terminal is input the conditions of servo system according serial command of servo system.
56	FOK	I	Focus OK input terminal. This terminal is the high level when focus servo operates.
57	IN SW	I	Close switch input terminal. L when the close switch turns on.
58	OUT SW	I	Open switch input terminal. L when the open switch turns on.
59	LSR	O	Laser diode ON/OFF control output terminal. ON at low level.
60	NRSC OUT	O	System code output terminal.
61	NRSC IN	I	System code input terminal.
62	RMCN	I	Input terminal from remote control sensor.
63,64	CON/ COF SW	I	Chucking switch detection input terminal
65	DIMMER SW NORMAL	I	The FL tube lights on normally when this terminal is the low level.
66	DIMMER SW OFF	I	The FL tube lights off when this terminal is the low level.
67	VOL DOWN	O	Volume control output terminal. Active "H".
68	VOL UP	O	Volume control output terminal. Active "H".
69, 70	CL ON/OFF	O	Chucking motor control output terminal
71	V _{ss}		Connect to GND.
72, 74	OSC	I	X'tal connection terminal
76	-32V		Power supply terminal for fluorescent indicator tube.
77~80	p, k, i, j	O	Fluorescent indicator tube segment output terminals. Active high.

M51943ASL (System reset)

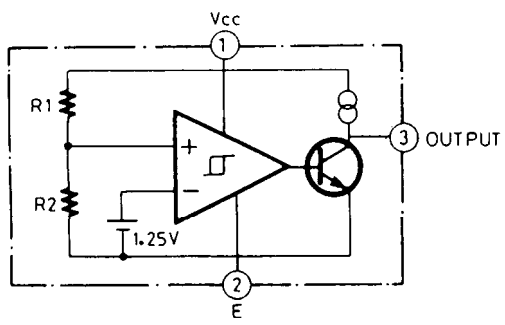

74HCU04P (Hex inverters)

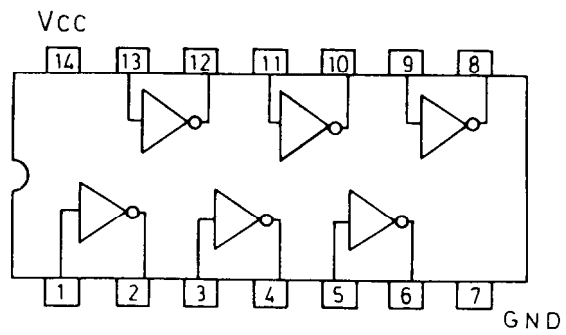

LA6510 (Power operation amp.)

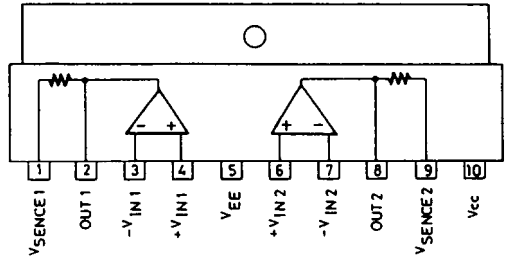

STA341M-L (Transistor array)

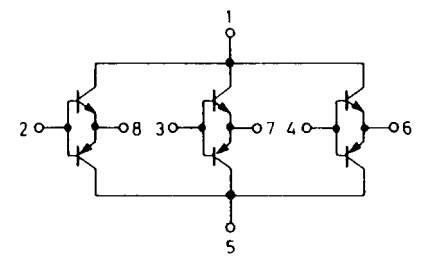

ADJUSTMENT PROCEDURES

Instruments required

Dual trace oscilloscope, Frequency counter, AF oscillator, Test disc (SONY YEDS-18), AC voltmeter, and Socket P4(Part no. 25050138)

1. Slide Balance Adjustment

1. Connect the audio oscillator to P112 SLD and the oscilloscope to P112 SLD and VS as shown below.
 2. Set the output of oscillator to the square wave, 5Hz, 2Vp-p.
 3. Turn the switch S101 to OPEN.
 4. Turn the power switch to ON.
 5. Confirm that the optical pickup does not move. (If it moves, control it by hand.)
 6. Adjust the semi-fixed resistor R139 so that the waveforms of channels 1 and 2 become the same phase.
- After adjustment, remove the audio oscillator and oscilloscope.

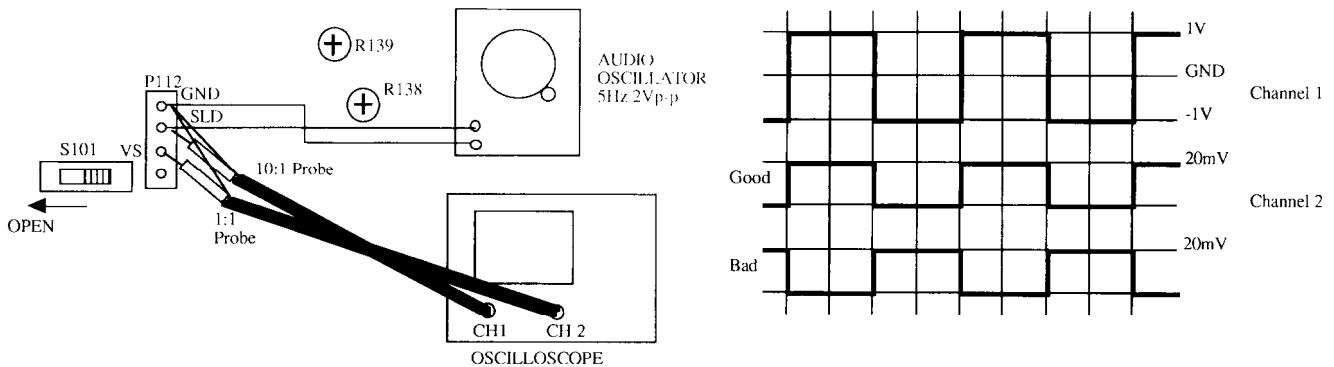

2. Slide Offset Adjustment

1. Connect the oscilloscope to P112 SLD.
2. Turn S101 to SHORT.
3. Adjust the semi-fixed resistor R138 so that the waveform on the oscilloscope becomes 0V.

3. Focus Offset Adjustment

- Load the test disc YEDS-18 on the tray and play the track 2.
 Connect the oscilloscope to the terminal P110.
 Adjust R111 so that the waveform on the oscilloscope becomes maximum.
 When the output is broad, set R111 to the mechanical center.

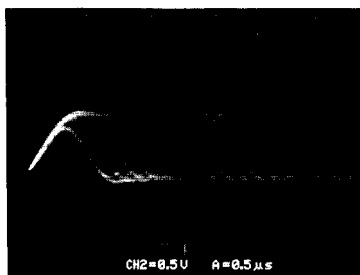
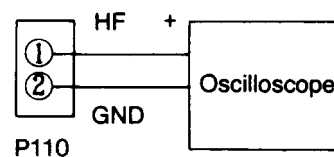

Photo 1



4. Tracking offset adjustment

Load the test disc YEDS-18 on the tray and play the track 2.

Turn R118 to minimum position. (Counter clockwise)

Connect the oscilloscope across pin 3 (TR) of P111 and P110. (Ground)

Adjust R115 until the center of tracking error signal on the oscilloscope becomes GND level.

Turn R118 to the mechanical center.

After adjustment, disconnect the oscilloscope.

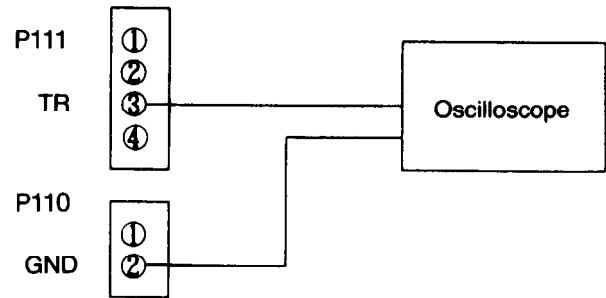
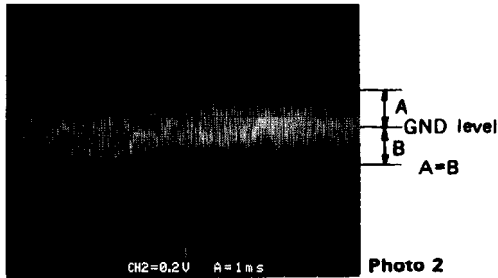

5. Focus gain adjustment

Set the output of AF oscillator to 800Hz, 1~1.5Vp-p.

Play the track 2 of test disc.

Connect the oscilloscope and the AF oscillator as shown below.

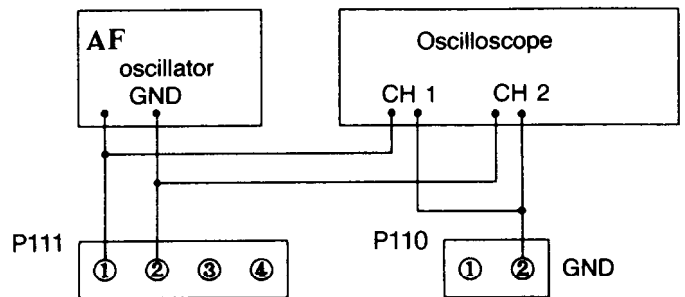
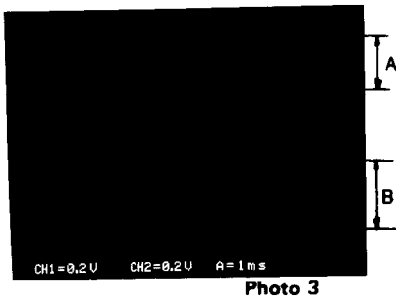

Adjust R116 until 800Hz components of channels 1 and 2 on oscilloscope become same level.

After adjustment, disconnect the AF oscillator and the oscilloscope.

6. Tracking gain adjustment

Set the output of AF oscillator to 1.2kHz, 1~1.5Vp-p.

Play the track 2 of test disc.

Connect the oscilloscope and the AF oscillator as shown below.

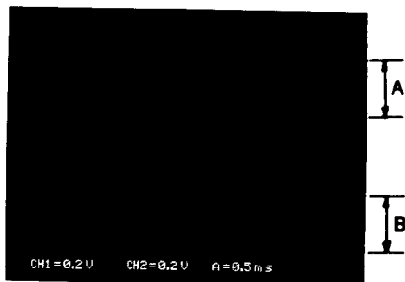
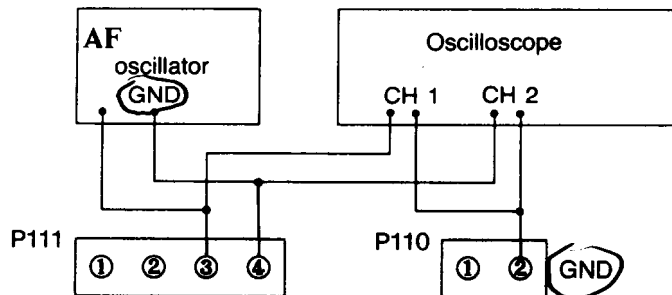

Photo 4



Adjust R118 until 1.2kHz components of channels 1 and 2 on oscilloscope become same level.

After adjustment, disconnect the AF oscillator and the oscilloscope.

After adjustment, confirm that the center of tracking error signal becomes GND level.

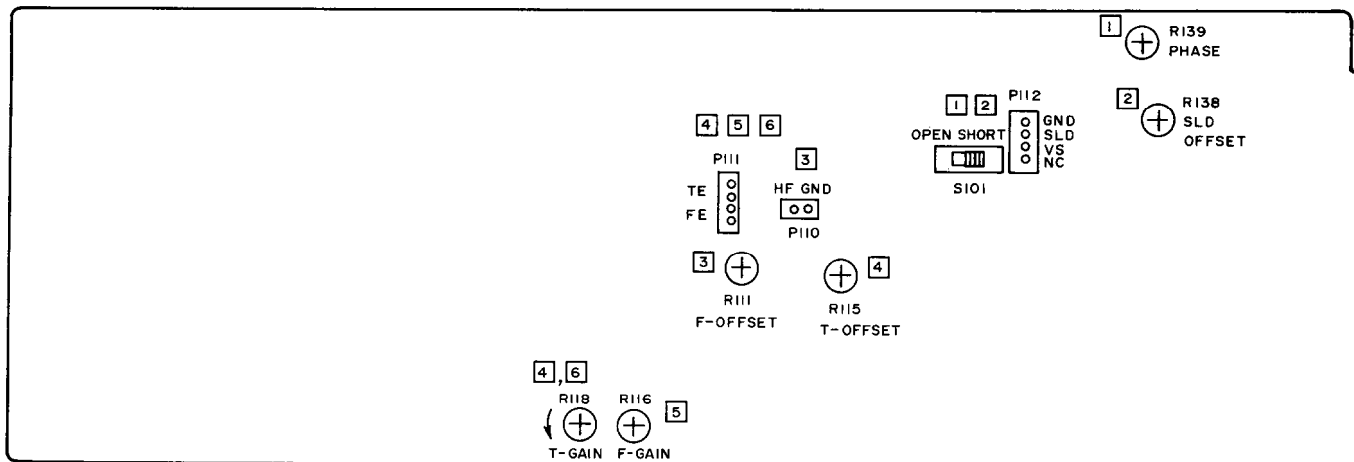

TROUBLESHOOTING GUIDE

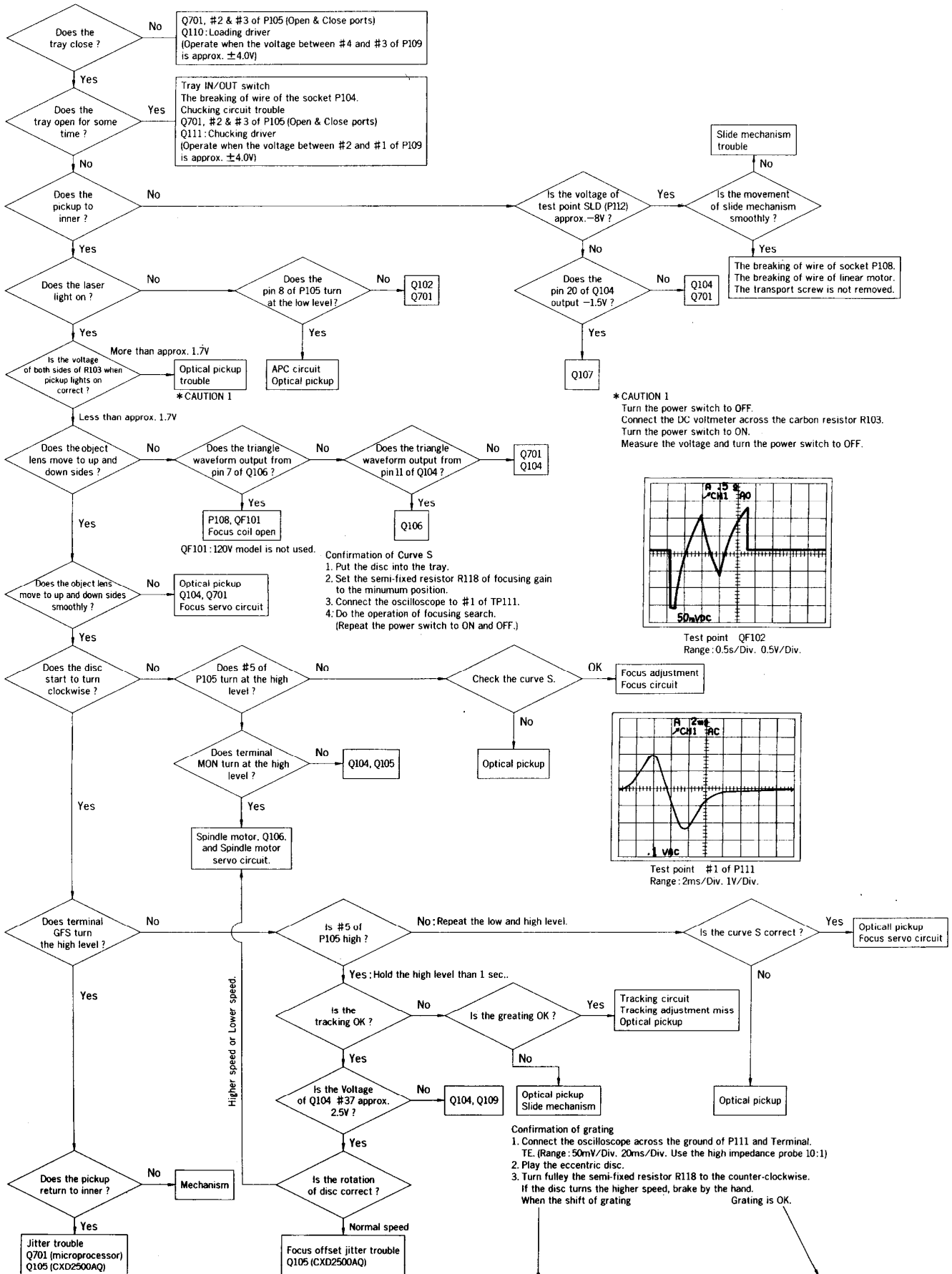

PC BOARD PARTS LIST

MODEL DX-706

MAIN CIRCUIT PC BOARD (NAAR-4272-1)

CIRCUIT NO.	PART NO.	DESCRIPTION
		ICs
Q116	24120031	TOTX178
Q302	222755	74HCU04P
Q401,Q402	22240520	SM5861AP
Q403-Q408	222902	NJM5532D-D
Q417	222654	NJM4556D
Q501	22240288	SM5813AP
Q953	222811	NJM4558D-D
Q954,Q955	222780053	78L05
Q956	222780055MIT	M5F78M05
		Transistors
Q409,Q410	2213090 or	DTA114YS or
Q415,Q416	2213590	RN2207
Q411,Q412	2212524 or	2SK363-GR or
	2212525	2SK363-BL
Q413,Q414	2211705 or	2SD655-E or
	2211706	2SD655-F
Q503	221281 or	DTC114YS or
Q601,Q604	2213570	RN1207
Q504	2211254 or	2SC1815-Y or
	2211255	2SC1815-GR
Q602	2213090 or	DTA114YS or
	2213590	RN2207
Q603	2211945	2SK246-GR
Q951	2201284,	2SD882-R,
	2201285 or	2SD882-Q or
	2201286	2SD882-P
Q952	2201274,	2SB772-R,
	2201275 or	2SB772-Q or
	2201276	2SB772-P
		Diodes
D601,D607	223163	1SS133
D608,D611	223163	1SS133
D612	224450822	MTZ8.2B
D613	223163	1SS133
D951-D954	22380045	RL-203
		Cores
L102,R303	230906	BL02RN2-R62
R305,R306	230906	BL02RN2-R62
		Coil
L301	231023	NCH-1062
		X'tal
X301	3010159	AT-38-169
		Capacitors
C191	354744709	47 μ F,16V,Elect.
C402,C403	393021017	100 μ F,6.3V,Elect.
C405-C408	374722234	0.022 μ F \pm 5%,50V,Plastic
C409,C410	393021017	100 μ F,6.3V,Elect.
C415,C416	391222217	220 μ F,6.3V,Elect.
C417,C418	374722234	0.022 μ F \pm 5%,50V,Plastic
C423	374722734	0.027 μ F \pm 5%,50V,Plastic
C425-C428	373302714	270pF \pm 5%,125V,Plastic
C429,C430	373301014	100pF \pm 5%,125V,Plastic
C431-C434	393144707	47 μ F,16V,Elect.
C437,C438	374722224	2200pF \pm 5%,50V,Plastic
C439,C440	374722734	0.027 μ F \pm 5%,50V,Plastic
C443,C444	374722224	2200pF \pm 5%,50V,Plastic
C449,C450	374722224	2200pF \pm 5%,50V,Plastic
C451,C452	372122024	2000pF \pm 5%,50V,Styrole
C453,C454	373301014	100pF \pm 5%,125V,Plastic
C455-C458	393144707	47 μ F,16V,Elect.
C459,C460	374722734	0.027 μ F \pm 5%,50V,Plastic
C461,C462	393154717	470 μ F,25V,Elect.
C463,C464	374722734	0.027 μ F \pm 5%,50V,Plastic
C465,C466	374722224	2200pF \pm 5%,50V,Plastic

CIRCUIT NO.	PART NO.	DESCRIPTION
		Capacitors
C467,C468	374722234	0.022 μ F \pm 5%,50V,Plastic
C469-C472	373301014	100pF \pm 5%,125V,Plastic
C474	374722234	0.022 μ F \pm 5%,50V,Plastic
C475,C476	393144707	47 μ F,16V,Elect.
C477-C480	373302714	270pF \pm 5%,125V,Plastic
C481,C482	373301014	100pF \pm 5%,125V,Plastic
C503	393022217	220 μ F,6.3V,Elect.
C508,C510	393021017	100 μ F,6.3V,Elect.
C603	393180107	1 μ F,50V,Elect.
C605	374724734	0.047 μ F \pm 5%,50V,Plastic
C606	374722234	0.022 μ F \pm 5%,50V,Plastic
C951,C952	374721044	0.1 μ F \pm 5%,50V,Plastic
C953	374722244	0.22 μ F \pm 5%,50V,Plastic
C954,C955	393154727	4700 μ F,25V,Elect.
C956,C957	374722734	0.027 μ F \pm 5%,50V,Plastic
C958	393122217	220 μ F,6.3V,Elect.
C960-C962	393144707	47 μ F,16V,Elect.
C963,C964	374721044	0.1 μ F \pm 5%,50V,Plastic
C967,C968	393144717	470 μ F,16V,Elect.
C971	393144707	47 μ F,16V,Elect.
C974	374722734	0.027 μ F \pm 5%,50V,Plastic
		Resistors
R951,R952	442520394	3.9ohm,1/2W,Metal oxide film
		Relay
RL601	25065174	NRL-2P1A-DC12-09
		Terminals
P111	25045172	HSJ1003-01-020
P401	25045351	NPJ-4PDWR197 C=026
		Plugs
P102	25055148	NPLG-4P132
P107	25055154	NPLG-10P138
P402	25055150	NPLG-6P134
		Sockets
JS401	25050267	NSCT-3P95
	2009990132	NSAS-2P0208
		Holder
	27190751	

DIGITAL CIRCUIT PC BOARD (NADG-4273-1/1A)

CIRCUIT NO.	PART NO.	DESCRIPTION
		ICs
Q102	22240404	CXA1571S
Q104	22240366	CXA1372S
Q105	22240487	CXD2500AQ
Q106	22240168	STA341M-L
Q107	222090	S2FR04
Q109	22240033	LA6500
Q110,Q111	22240034	LA6510
Q114	22240018	M51943ASL
Q902	222790055MIT	M5F79M05
Q903	222780055MIT	M5F78M05
		Transistors
Q101,Q113	2211503 or	2SA950-O or
Q904	2211504	2SA950-Y
Q103	221281 or	DTC114YS or
	2213570	RN1207
Q112	2211163 or	2SC2120-O or
	2211164	2SC2120-Y
Q115	2211454 or	2SA1015-Y or
	2211455	2SA1015-GR
		Diodes
D101,D903	223163	1SS133
D102,D103	224451102	MTZ11B

CIRCUIT NO.	PART NO.	DESCRIPTION	CIRCUIT NO.	PART NO.	DESCRIPTION
	Diodes			IC protectors	
D901	22380039	1D4B42	QF101,QF102	252112	△ ICPN15 <P/W>
D904	224452702 or 224652702	MTZ27B or HZ27EB2		Switch	
	Coil		S101	25065364	NSS-12138
L101	231023	NCH-1062	HEADPHONE TERMINAL PC BOARD (NAAF-4274-1)		
	Core		CIRCUIT NO.	PART NO.	DESCRIPTION
L102	230906	BL02RN2-R62	C483,C484	374721024	1000pF ± 5%,50V,Plastic capacitors
	Capacitors		P403	25045221	HLJ0540-01-410,Terminal
C101,C102	393121017	100 μ F,6.3V,Elect.	OUTPUT VOLUME PC BOARD (NAAF-4276-1)		
C103	374724724	4700pF ± 5%,50V,Plastic	CIRCUIT NO.	PART NO.	DESCRIPTION
C105,C107	393121017	100 μ F,6.3V,Elect.	P401A	2009990191	NSAS-12P0257,Socket
C108,C110	374721044	0.1 μ F ± 5%,50V,Plastic	P701	25055149	NPLG-5P133,Plug
C111	374724734	0.047 μ F ± 5%,50V,Plastic	R491,R492	5104280	N16RGM20KB30F,Variable resistor
C112	374721034	0.01 μ F ± 5%,50V,Plastic	S721	25030331	NRSF-123-30SRRU,Rotary switch
C113	374722224	2200pF ± 5%,50V,Plastic	SENSOR PC BOARD (NAETC-4277-1)		
C114-C116	374721044	0.1 μ F ± 5%,50V,Plastic	CIRCUIT NO.	PART NO.	DESCRIPTION
C118	354781009	10 μ F,50V,Elect.	Q701	24130003	GP1U50XS,IC
C119,C123	374721044	0.1 μ F ± 5%,50V,Plastic	C718	354744709	47 μ F,16V,Elect. capacitor
C121,C128	393121017	100 μ F,6.3V,Elect.	DISPLAY CIRCUIT PC BOARD (NADIS-4275-1/1A)		
C124	354780229	2.2 μ F,50V,Elect.	CIRCUIT NO.	PART NO.	DESCRIPTION
C125	374721034	0.01 μ F ± 5%,50V,Plastic		FL tube	
C126	393180107	1 μ F,50V,Elect.	Q702	212101	7-BT-151GK
C127	354763309	33 μ F,35V,Elect.		ICs	
C130,C132	374721034	0.01 μ F ± 5%,50V,Plastic	Q701	22240521	CXP50116-166
C131	374724724	4700pF ± 5%,50V,Plastic	Q703	222963 or 22240322	LB1630 or LB1639
C135	374722234	0.022 μ F ± 5%,50V,Plastic		Transistors	
C136,C137	374721034	0.01 μ F ± 5%,50V,Plastic	Q704	2212132 or 2212133	2SC2021-R or 2SC2021-S
C138	393121017	100 μ F,6.3V,Elect.	Q705	2213183 or 2213184	2SA937-R or 2SA937-Q
C140	374721524	1500pF ± 5%,50V,Plastic		Diodes	
C141,C147	374721044	0.1 μ F ± 5%,50V,Plastic	D701	224450623	MTZ6.2C
C142	393022217	220 μ F,6.3V,Elect.	D704	224450562	MTZ5.6B
C146	374721034	0.01 μ F ± 5%,50V,Plastic	D705-D707	223163	1SS133
C148,C163	393144707	47 μ F,16V,Elect.		Capacitors	
C149	374721024	1000pF ± 5%,50V,Plastic	C703	391244707	47 μ F,16V,Elect.
C151-C153	393144707	47 μ F,16V,Elect.	C704,C713	374721044	0.1 μ F ± 5%,50V,Plastic
C161	374722234	0.022 μ F ± 5%,50V,Plastic	C714	354764709	47 μ F,35V,Elect.
C162	374724734	0.047 μ F ± 5%,50V,Plastic	C716	354781099	0.1 μ F,50V,Elect.
C165,C166	393144707	47 μ F,16V,Elect.		Resistor	
C167,C168	393141017	100 μ F,16V,Elect.	R737	49163472406	4.7kohm × 6,1/10W,Network
C903,C904	374721044	0.1 μ F ± 5%,50V,Plastic		Ceramic oscillator	
C905,C906	354752229	2200 μ F,25V,Elect.	X701	3010188	CST4.50MGW040
C909,C910	391222217	220 μ F,6.3V,Elect.		Switches	
C911,C912	374722234	0.022 μ F ± 5%,50V,Plastic	S701-S723	25035548	NPS-111-S510
C919	374721044	0.1 μ F ± 5%,50V,Plastic		Sockets	
C920,C921	354784709	47 μ F,50V,Elect.	P101A	2006391255	NSAS-12P0159
	Resistors		P105A	2006392450	NSAS-24P0261
R111	5210060	N06HR2.2KBD,Semi-fixed	P106A	2006392050	NSAS-20P0259
R115,R116	5210066	N06HR22KBD,Semi-fixed	P701A	2006391010	NSAS-10P0158
R118	5210066	N06HR22KBD,Semi-fixed		Holder	
R138	5210064	N06HR10KBD,Semi-fixed		27190778A	
R139	5210001	N06HR100BDM,Semi-fixed	POWER SUPPLY CIRCUIT PC BOARD (NAPS-4278-1)		
	Plugs		CIRCUIT NO.	PART NO.	DESCRIPTION
P101	25055150	NPLG-6P134	C941	3500065A	△ DE7150F 103P AC400/125V,IS capacitor
P103	25055139	NPLG-9P123			
P104	25055149	NPLG-5P133	S941	25035558	△ NPS-111-L520,Power switch
P105	25055156	NPLG-12P140		27301216	△ Cover for C941
P106	25055154	NPLG-10P138	POWER SUPPLY CIRCUIT PC BOARD (NAPS-4278-1)		
P108	25055151	NPLG-7P135	CIRCUIT NO.	PART NO.	DESCRIPTION
P109	25055150	NPLG-6P134	C941	3500065A	△ DE7150F 103P AC400/125V,IS capacitor
P110	25055038	NPLG-2P29			
P111,P112	25055045	NPLG-4P33			
	Sockets				
P102	2009990192	NSAS-8P0258			
P107	2009990193	NSAS-20P0259			

PC BOARD PARTS LIST

MODEL DX-708

MAIN CIRCUIT PC BOARD (NAAR-4272-2)

CIRCUIT NO.	PART NO.	DESCRIPTION	CIRCUIT NO.	PART NO.	DESCRIPTION
					Capacitors
			C429,C430	373301014	100pF ± 5%, 125V, Plastic
			C431-C434	393144707	47 μ F, 16V, Elect.
			C437,C438	374722224	2200pF ± 5%, 50V, Plastic
			C439,C440	374722734	0.027 μ F ± 5%, 50V, Plastic
			C443,C444	374722224	2200pF ± 5%, 50V, Plastic
			C449,C450	374722224	2200pF ± 5%, 50V, Plastic
			C451,C452	372122024	2000pF ± 5%, 50V, Styrole
			C453,C454	373301014	100pF ± 5%, 125V, Plastic
			C455-C458	393144707	47 μ F, 16V, Elect.
			C459,C460	374721034	0.01 μ F ± 5%, 50V, Plastic
			C461,C462	393083317	330 μ F, 50V, Elect.
			C463-C468	374722234	0.022 μ F ± 5%, 50V, Plastic
			C469-C472	373301014	100pF ± 5%, 125V, Plastic
			C474	374722234	0.022 μ F ± 5%, 50V, Plastic
			C475,C476	393144707	47 μ F, 16V, Elect.
			C477-C480	373302714	270pF ± 5%, 125V, Plastic
			C481,C482	373301014	100pF ± 5%, 125V, Plastic
			C503	393022217	220 μ F, 6.3V, Elect.
			C508,C510	393021017	100 μ F, 6.3V, Elect.
			C603	393180107	1 μ F, 50V, Elect.
			C605	374724734	0.047 μ F ± 5%, 50V, Plastic
			C606	374724744	0.47 μ F ± 5%, 50V, Plastic
			C951,C952	374721044	0.1 μ F ± 5%, 50V, Plastic
			C953	374724744	0.47 μ F ± 5%, 50V, Plastic
			C954,C955	393154727	4700 μ F, 25V, Elect.
			C956,C957	374722244	0.22 μ F ± 5%, 50V, Plastic
			C958	393122217	220 μ F, 6.3V, Elect.
			C960-C962	393144707	47 μ F, 16V, Elect.
			C963-C966	374721044	0.1 μ F ± 5%, 50V, Plastic
			C967-C970	354784719	470 μ F, 50V, Elect.
			C971	393144707	47 μ F, 16V, Elect.
			C974	374721044	0.1 μ F ± 5%, 50V, Plastic
			C976	374721034	0.01 μ F ± 5%, 50V, Plastic
					Resistors
			R951,R952	442520394	3.9ohm, 1/2W, Metal oxide film
					Relay
			RL601	25065174	NRL-2P1A-DC12-09
					Terminals
			P111	25045172	HSJ1003-01-020
			P401	25045351	NPJ-4PDWR197
					Plugs
			P102	25055148	NPLG-4P132
			P107	25055154	NPLG-10P138
			P402	25055150	NPLG-6P134
					Sockets
			JS401	25050267	NSCT-3P95
				2009990132	NSAS-2P0208
					Holder
				27190751	
					ICs
Q116	24120031	TOTX178			
Q302	222755	74HCU04P			
Q401,Q402	22240520	SM5861AP			
Q403-Q408	222902	NJM5532D-D			
Q417	222654	NJM4556D			
Q501	22240288	SM5813AP			
Q502	226027	HCPL-2601			
Q953	222811	NJM4558D-D			
Q954,Q955	222780053	78L05			
Q956	222780055MIT	M5F78M05			
					Transistors
Q409,Q410	2213090 or 2213590	DTA114YS or RN2207			
Q411,Q412	2212524 or 2212525	2SK363-GR or 2SK363-BL			
Q413,Q414	2211705 or 2211706	2SD655-E or 2SD655-F			
Q415,Q416	2213090 or 2213590	DTA114YS or RN2207			
Q503	221281 or 2213570	DTC114YS or RN1207			
Q504	2211254 or 2211255	2SC1815-Y or 2SC1815-GR			
Q601,Q604	221281 or 2213570	DTC114YS or RN1207			
Q602	2213090 or 2213590	DTA114YS or RN2207			
Q603	2211945	2SK246-GR			
Q951	2201284, 2201285 or 2201286	2SD882-R, 2SD882-Q or 2SD882-P			
Q952	2201274, 2201275 or 2201276	2SB772-R, 2SB772-Q or 2SB772-P			
					Diodes
D601,D607	223163	1SS133			
D608,D611	223163	1SS133			
D612	224450822	MTZ8.2B			
D613	223163	1SS133			
D951-D954	22380045	RL-203			
					Cores
L102,R303	230906	BL02RN2-R62			
R305,R306	230906	BL02RN2-R62			
					Coil
L301	231023	NCH-1062			
					X'tal
X302	3010189	DOC-80S			
					Capacitors
C191	354744709	47 μ F, 16V, Elect.			
C402,C403	393021017	100 μ F, 6.3V, Elect.			
C405-C408	374722234	0.022 μ F ± 5%, 50V, Plastic			
C409,C410	393021017	100 μ F, 6.3V, Elect.			
C415,C416	393121027	1000 μ F, 6.3V, Elect.			
C417,C418	374722234	0.022 μ F ± 5%, 50V, Plastic			
C423	374721044	0.1 μ F ± 5%, 50V, Plastic			
C425-C428	373302714	270pF ± 5%, 125V, Plastic			

DIGITAL CIRCUIT PC BOARD (NADG-4273-2/2A)

CIRCUIT NO.	PART NO.	DESCRIPTION
	ICs	
Q102	22240404	CXA1571S
Q104	22240366	CXA1372S
Q105	22240487	CXD2500AQ
Q106	22240168	STA341M-L
Q107	222090	S2FR04
Q109	22240033	LA6500
Q110,Q111	22240034	LA6510
Q114	22240018	M51943ASL
Q901	222780055MIT	M5F78M05
Q902	222790055MIT	M5F79M05
	Transistors	
Q101,Q113	2211503 or	2SA950-O or
Q904	2211504	2SA950-Y
Q103	221281 or	DTC114YS or
	2213570	RN1207
Q112	2211163 or	2SC2120-O or
	2211164	2SC2120-Y
Q115	2211454 or	2SA1015-Y or
	2211455	2SA1015-GR
	Diodes	
D101,D903	223163	1SS133
D102,D103	224451102	MTZ11B
D901,D902	22380039	1D4B42
D904	224452702 or	MTZ27B or
	224652702	HZ27EB2
	Coil	
L101	231023	NCH-1062
	Core	
L102	230906	BL02RN2-R62
	Capacitors	
C101,C102	393121017	100 μ F,6.3V,Elect.
C103	374724724	4700pF \pm 5%,50V,Plastic
C105,C107	393121017	100 μ F,6.3V,Elect.
C108,C110	374721044	0.1 μ F \pm 5%,50V,Plastic
C111	374724734	0.047 μ F \pm 5%,50V,Plastic
C112	374721034	0.01 μ F \pm 5%,50V,Plastic
C113	374722224	2200pF \pm 5%,50V,Plastic
C114-C116	374721044	0.1 μ F \pm 5%,50V,Plastic
C118	354781009	10 μ F,50V,Elect.
C119,C123	374721044	0.1 μ F \pm 5%,50V,Plastic
C121,C128	393121017	100 μ F,6.3V,Elect.
C124	354780229	2.2 μ F,50V,Elect.
C125	374721034	0.01 μ F \pm 5%,50V,Plastic
C126	393180107	1 μ F,50V,Elect.
C127	354763309	33 μ F,35V,Elect.
C130,C132	374721034	0.01 μ F \pm 5%,50V,Plastic
C131	374724724	4700pF \pm 5%,50V,Plastic
C135	374722234	0.022 μ F \pm 5%,50V,Plastic
C136,C137	374721034	0.01 μ F \pm 5%,50V,Plastic
C138	393121017	100 μ F,6.3V,Elect.
C140	374721524	1500pF \pm 5%,50V,Plastic
C141,C147	374721044	0.1 μ F \pm 5%,50V,Plastic
C142	393022217	220 μ F,6.3V,Elect.
C146	374721034	0.01 μ F \pm 5%,50V,Plastic
C148,C163	393144707	47 μ F,16V,Elect.
C149	374721024	1000pF \pm 5%,50V,Plastic

CIRCUIT NO.	PART NO.	DESCRIPTION
	Capacitors	
C151-C153	393144707	47 μ F,16V,Elect.
C161	374722234	0.022 μ F \pm 5%,50V,Plastic
C162	374724734	0.047 μ F \pm 5%,50V,Plastic
C165,C166	393144707	47 μ F,16V,Elect.
C167,C168	393141017	100 μ F,16V,Elect.
C903,C904	374721044	0.1 μ F \pm 5%,50V,Plastic
C905,C906	354752229	2200 μ F,25V,Elect.
C909,C910	391222217	220 μ F,6.3V,Elect.
C911,C912	374722234	0.022 μ F \pm 5%,50V,Plastic
C917,C918	354752229	2200 μ F,25V,Elect.
C919	374721044	0.1 μ F \pm 5%,50V,Plastic
C920,C921	354784709	47 μ F,50V,Elect.
	Resistors	
R111	5210060	N06HR2.2KBD,Semi-fixed
R115,R116	5210066	N06HR22KBD,Semi-fixed
R118	5210066	N06HR22KBD,Semi-fixed
R138	5210064	N06HR10KBD,Semi-fixed
R139	5210001	N06HR100BDM,Semi-fixed
	Plugs	
P101	25055150	NPLG-6P134
P103	25055139	NPLG-9P123
P104	25055149	NPLG-5P133
P105	25055156	NPLG-12P140
P106	25055154	NPLG-10P138
P108	25055151	NPLG-7P135
P109	25055150	NPLG-6P134
P110	25055038	NPLG-2P29
P111,P112	25055045	NPLG-4P33
	Sockets	
P102	2009990192	NSAS-8P0258
P107	2009990193	NSAS-20P0259
	IC protectors	
QF101,QF102	252112	Δ ICPN15 <P/W>
	Switch	
S101	25065364	NSS-12138

HEADPHONE TERMINAL PC BOARD (NAAF-4274-2)

CIRCUIT NO.	PART NO.	DESCRIPTION
C483,C484	374721024	1000pF \pm 5%,50V,Plastic capacitors
P403	25045221	HLJ0540-01-410,Terminal

OUTPUT VOLUME PC BOARD (NAAF-4276-2)

CIRCUIT NO.	PART NO.	DESCRIPTION
P401A	2009990191	NSAS-12P0257,Socket
P701	25055149	NPLG-5P133,Plug
R491,R492	5104280	N16RGM20KB30F,Variable resistor
S721	25030331	NRSF-123-30SRRU,Rotary switch

SENSOR PC BOARD (NAETC-4277-2)

CIRCUIT NO.	PART NO.	DESCRIPTION
Q701	24130003	GP1U50XS,IC
C718	354744709	47 μ F,16V,Elect. capacitor

PC BOARD VIEW FROM BOTTOM SIDE

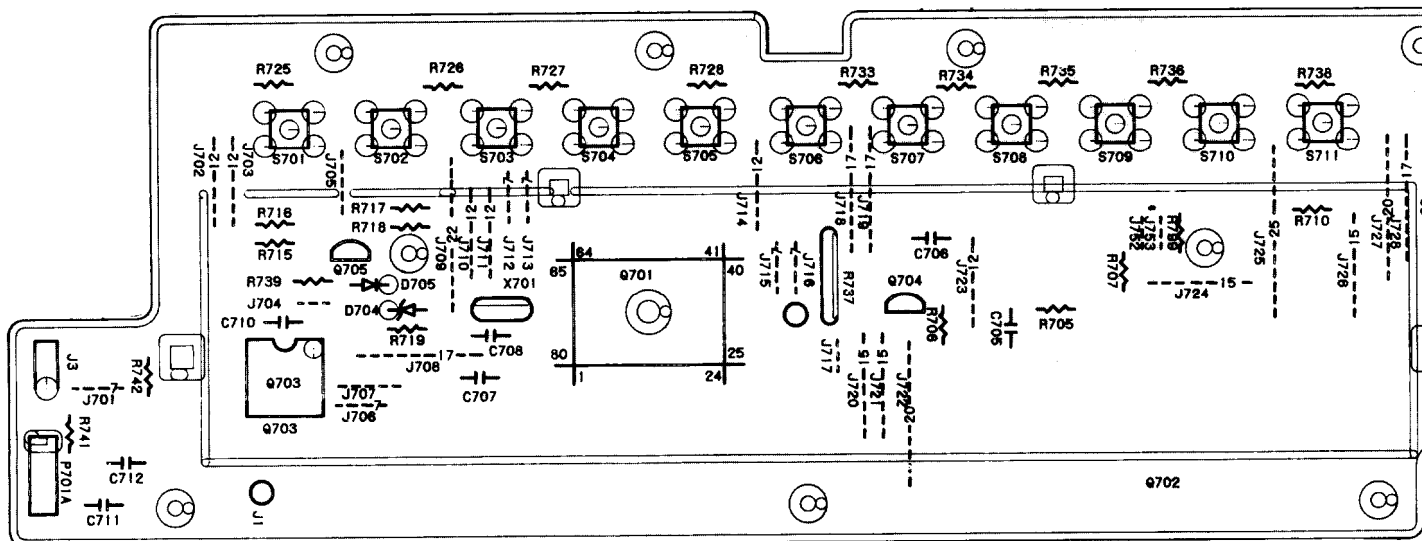

DISPLAY CIRCUIT PC BOARD (NADIS-4275-2/2A)

CIRCUIT NO.	PART NO.	DESCRIPTION
	FL tube	
Q702	212101	7-BT-151GK
	ICs	
Q701	22240521	CXP50116-166
Q703	222963 or 22240322	LB1630 or LB1639
	Transistors	
Q704	2212132 or 2212133	2SC2021-R or 2SC2021-S
Q705	2213183 or 2213184	2SA937-R or 2SA937-Q
	Diodes	
D701	224450623	MTZ6.2C
D704	224450562	MTZ5.6B
D705-D707	223163	1SS133
	Capacitors	
C703	391244707	47 μ F, 16V, Elect.
C704, C713	374721044	0.1 μ F \pm 5%, 50V, Plastic
C714	354764709	47 μ F, 35V, Elect.
C716	354781099	0.1 μ F, 50V, Elect.
	Resistor	
R737	49163472406	4.7kohm \times 6, 1/10W, Network
	Ceramic oscillator	
X701	3010188	CST4.50MGW040
	Switches	
S701-S723	25035548	NPS-111-S510
	Sockets	
P101A	2006391255	NSAS-12P0159
P105A	2006392450	NSAS-24P0261
P106A	2006392050	NSAS-20P0259
P701A	2006391010	NSAS-10P0158
	Holder	
	27190778A	

POWER SUPPLY CIRCUIT PC BOARD (NAPS-4278-2)

CIRCUIT NO.	PART NO.	DESCRIPTION
C941	3500065A	Δ DE7150F 103P AC400/125V, IS capacitor
S941	25035558 27301216	Δ NPS-111-L520, Power switch Δ Cover for C941

NOTE: <P>: Only 230V model
<W>: Only Worldwide model

NOTE: THE COMPONENTS IDENTIFIED BY MARK Δ ARE CRITICAL FOR RISK OF FIRE AND ELECTRIC SHOCK. REPLACE ONLY WITH PART NUMBER SPECIFIED.

BLOCK DIAGRAM

MODEL DX-706

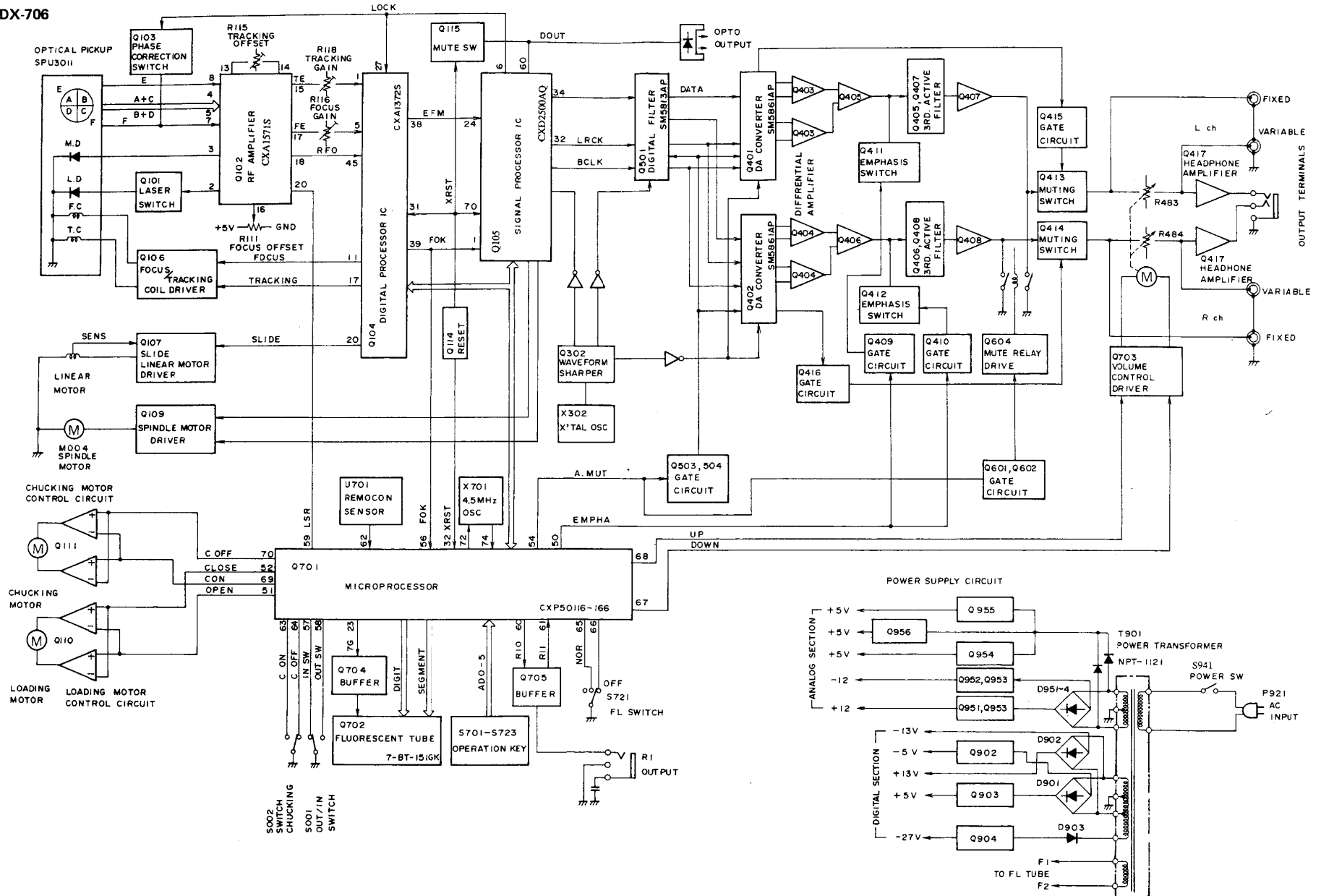

BLOCK DIAGRAM

MODEL DX-708

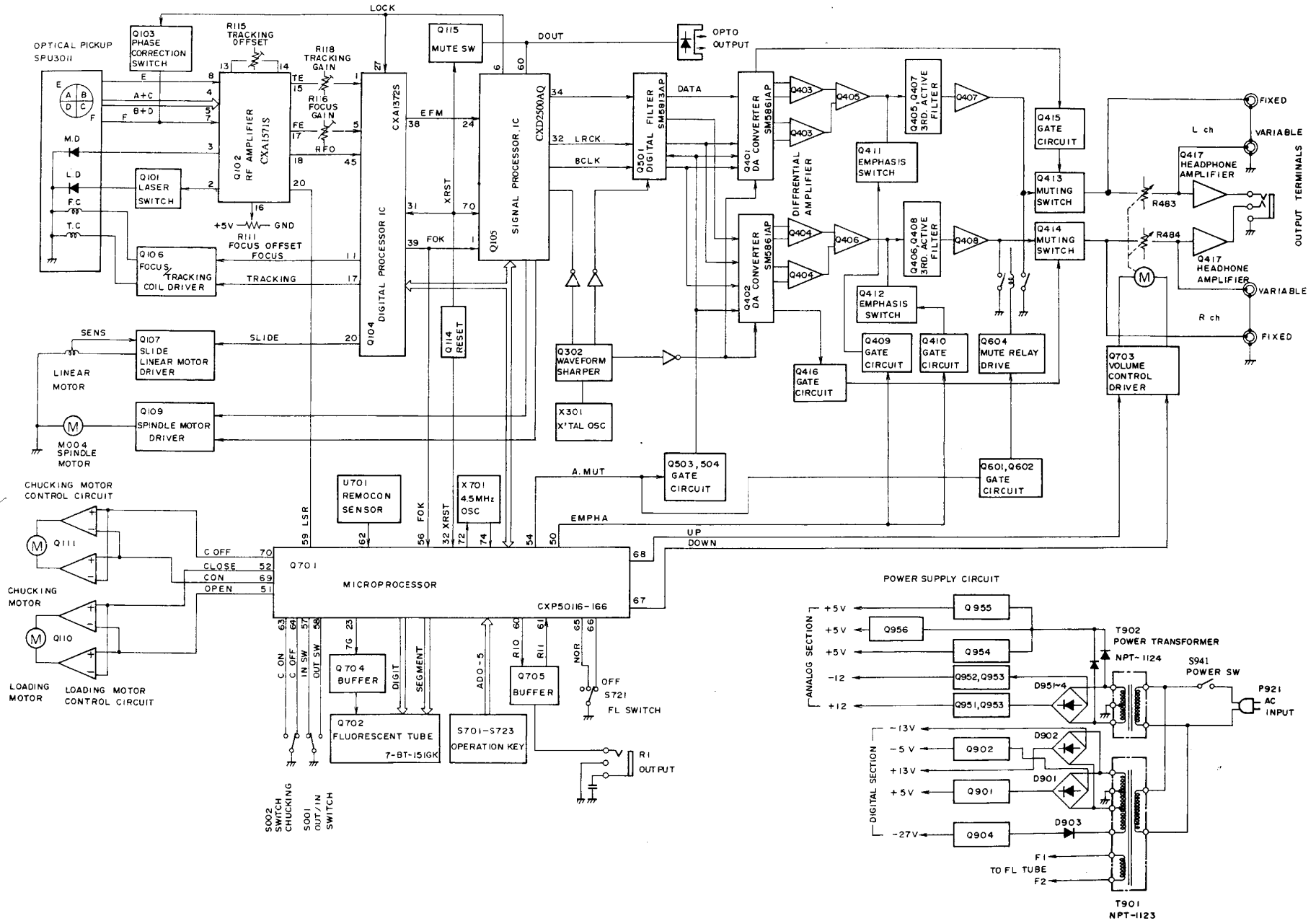

SCHEMATIC DIAGRAM

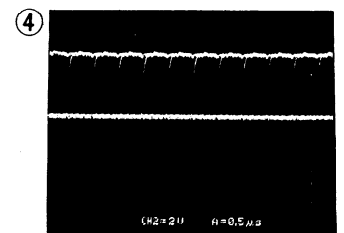
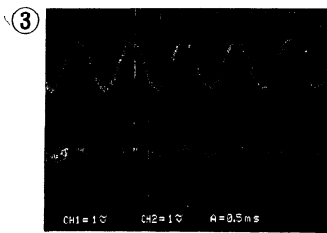
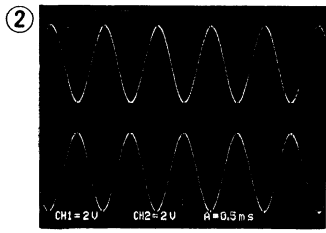
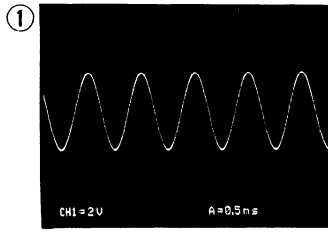
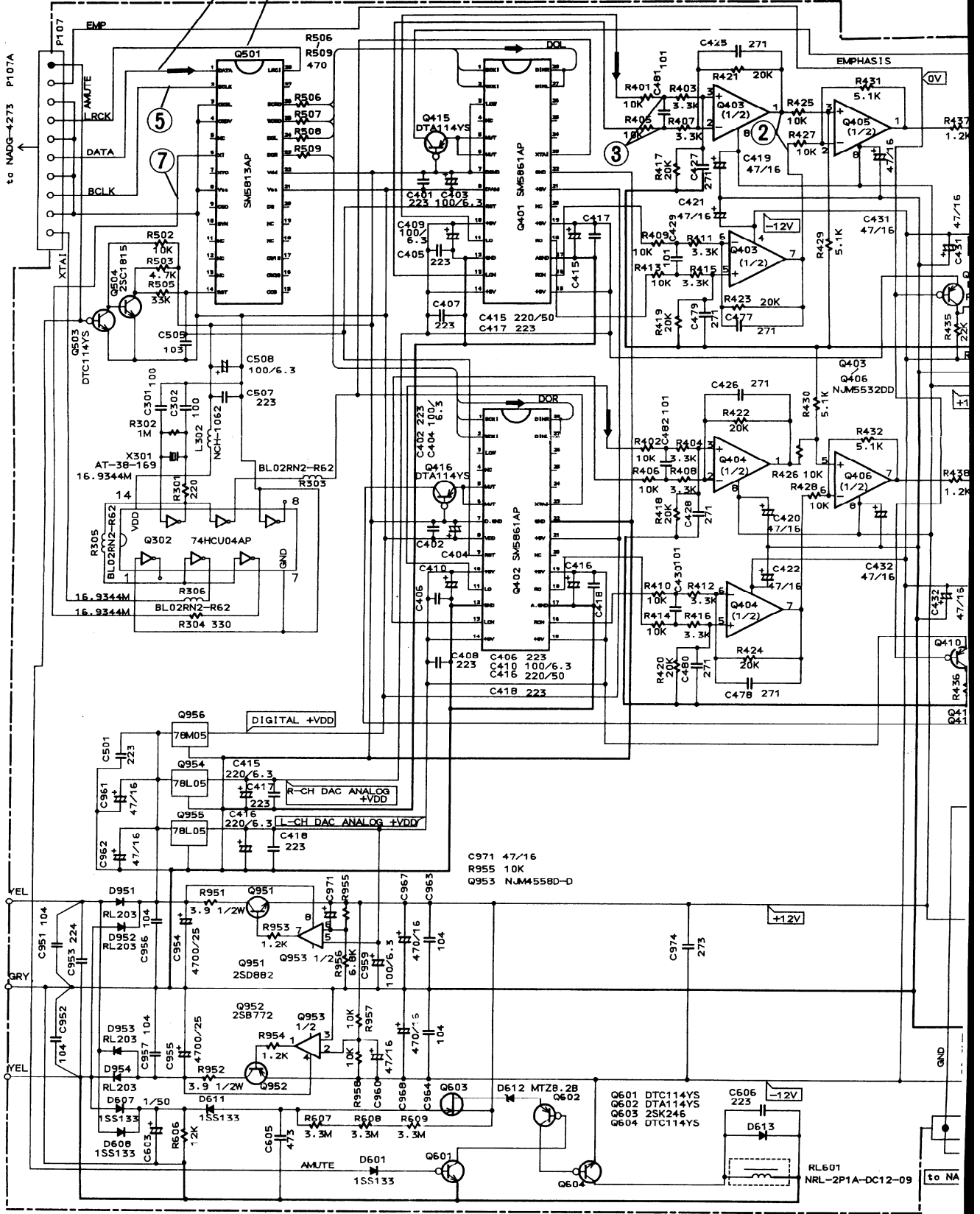

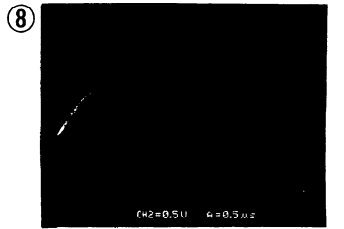
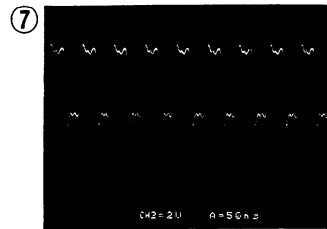
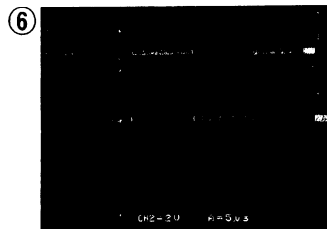
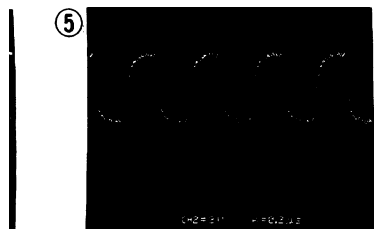
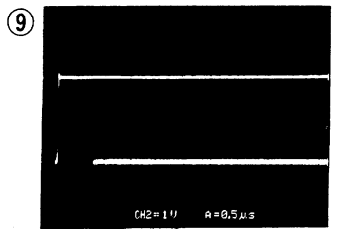
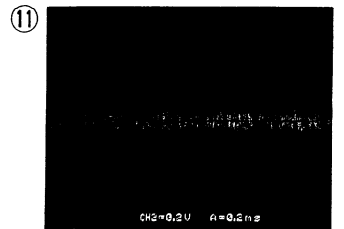
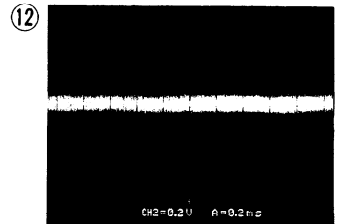
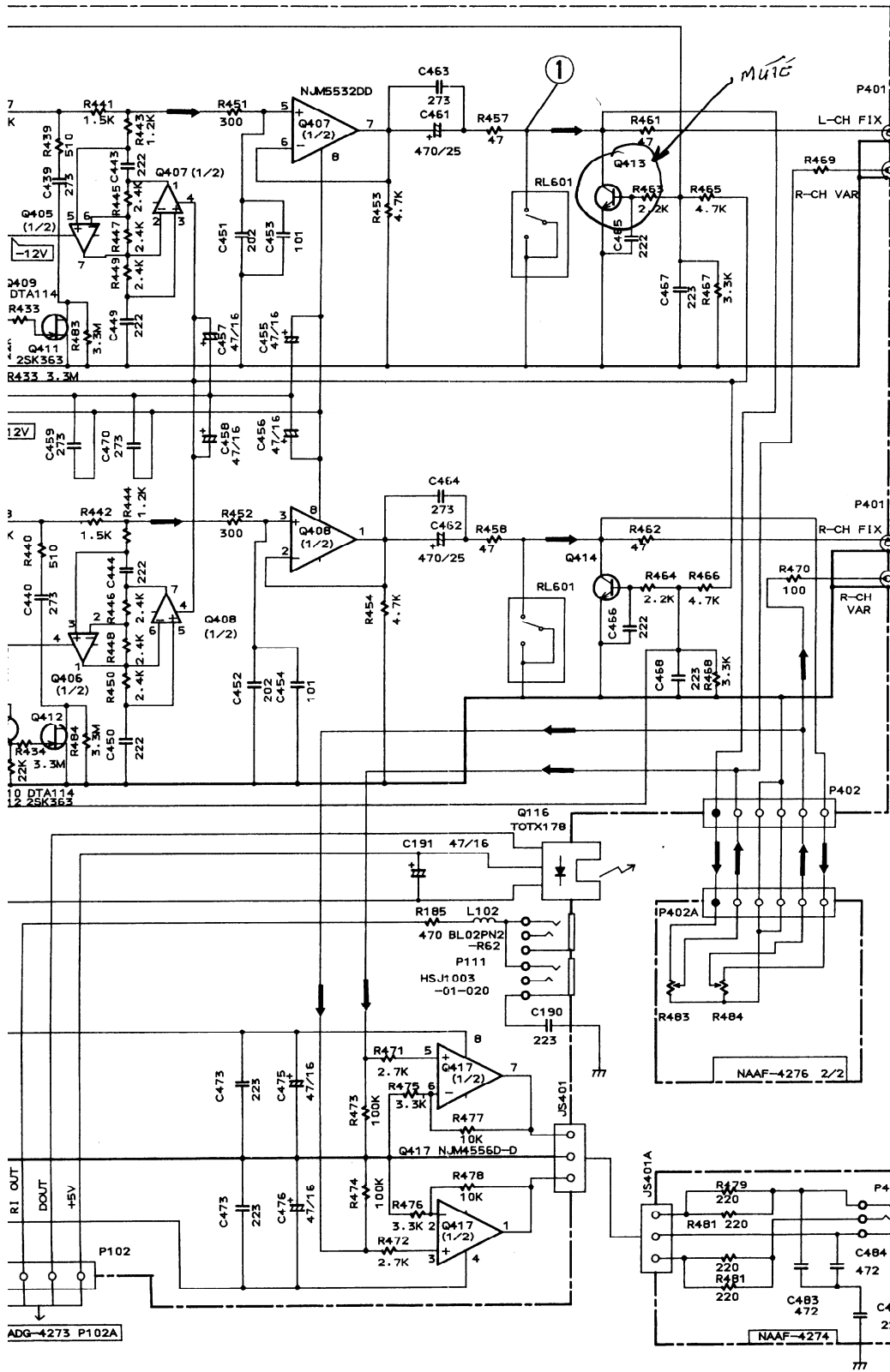

80L/90/

SCHEMATIC DIAGRAM

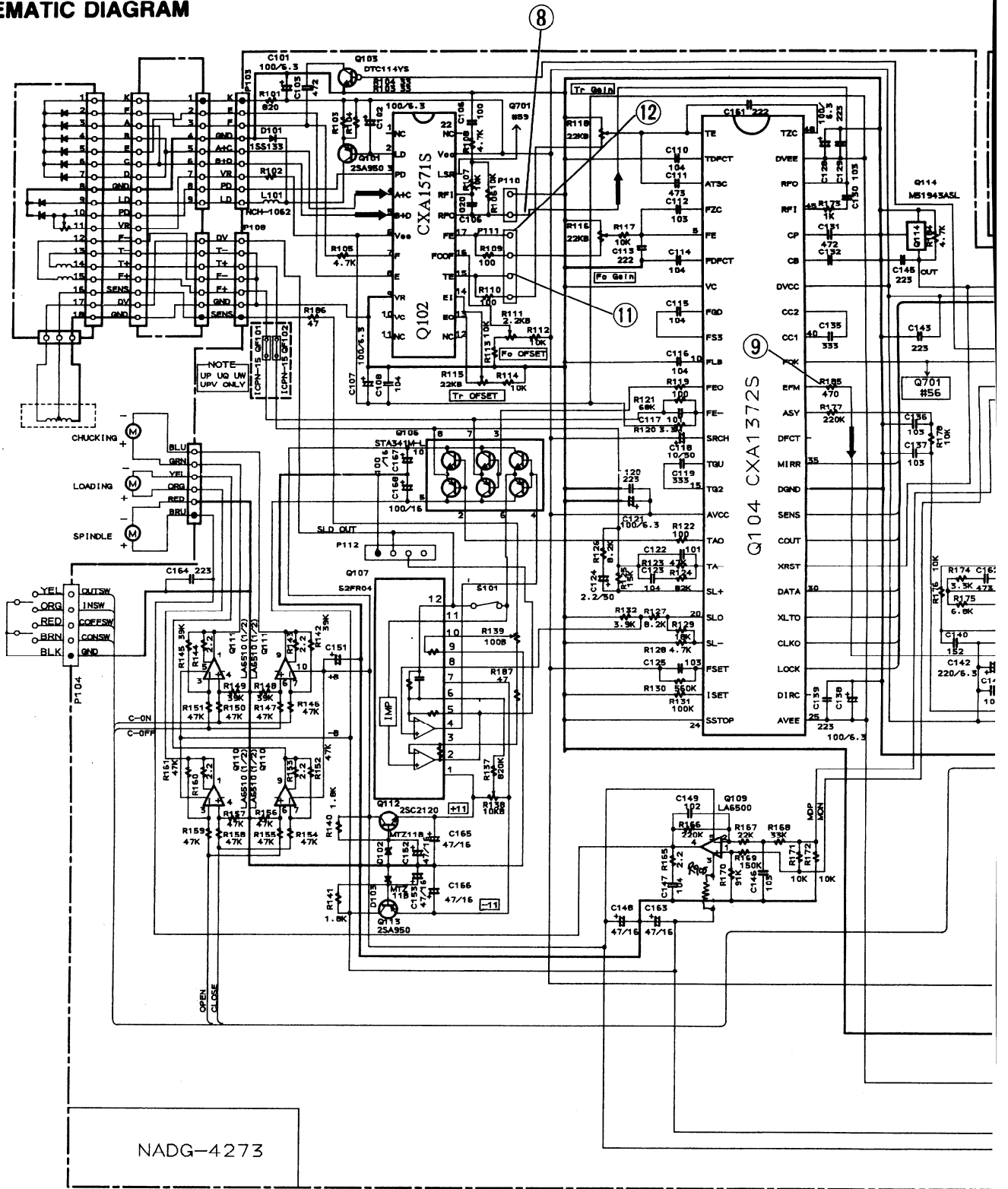

NOTE

- THE COMPONENTS IDENTIFIED BY MARK Δ ARE CRITICAL FOR SAFETY. REPLACE ONLY WITH PART NUMBER SPECIFIED.
- VOLTAGE (MEASURED WITH VOLTMETER) \square IS DC VOLTAGE. (NO INPUT SIGNAL)
- ALL PNP TRANSISTORS ARE EQUIVALENT TO 2SA1015-GR UNLESS OTHERWISE NOTED.
- ALL NPN TRANSISTORS ARE EQUIVALENT TO 2SC1815-GR UNLESS OTHERWISE NOTED.
- ALL DIODES ARE EQUIVALENT TO 1SS133 UNLESS OTHERWISE NOTED.
- ELECTROLYTIC CAPACITORS ($\#$) ARE IN μ F/WV.
- ALL CAPACITORS ARE IN pF/50WV UNLESS OTHERWISE NOTED.
EX) 3pF \rightarrow 030, 33pF \rightarrow 330, 330pF \rightarrow 331, 0.033 μ F \rightarrow 333
- ALL RESISTORS ARE IN OHMS 1/4 WATTS UNLESS OTHERWISE NOTED.
- THE THICK LINES IN PC BOARD ARE THE PRINTING SIDE OF THE PARTS.
EX) PRINTING SIDE
- CIRCUIT IS SUBJECT TO CHANGE FOR IMPROVEMENT.

DLOO2

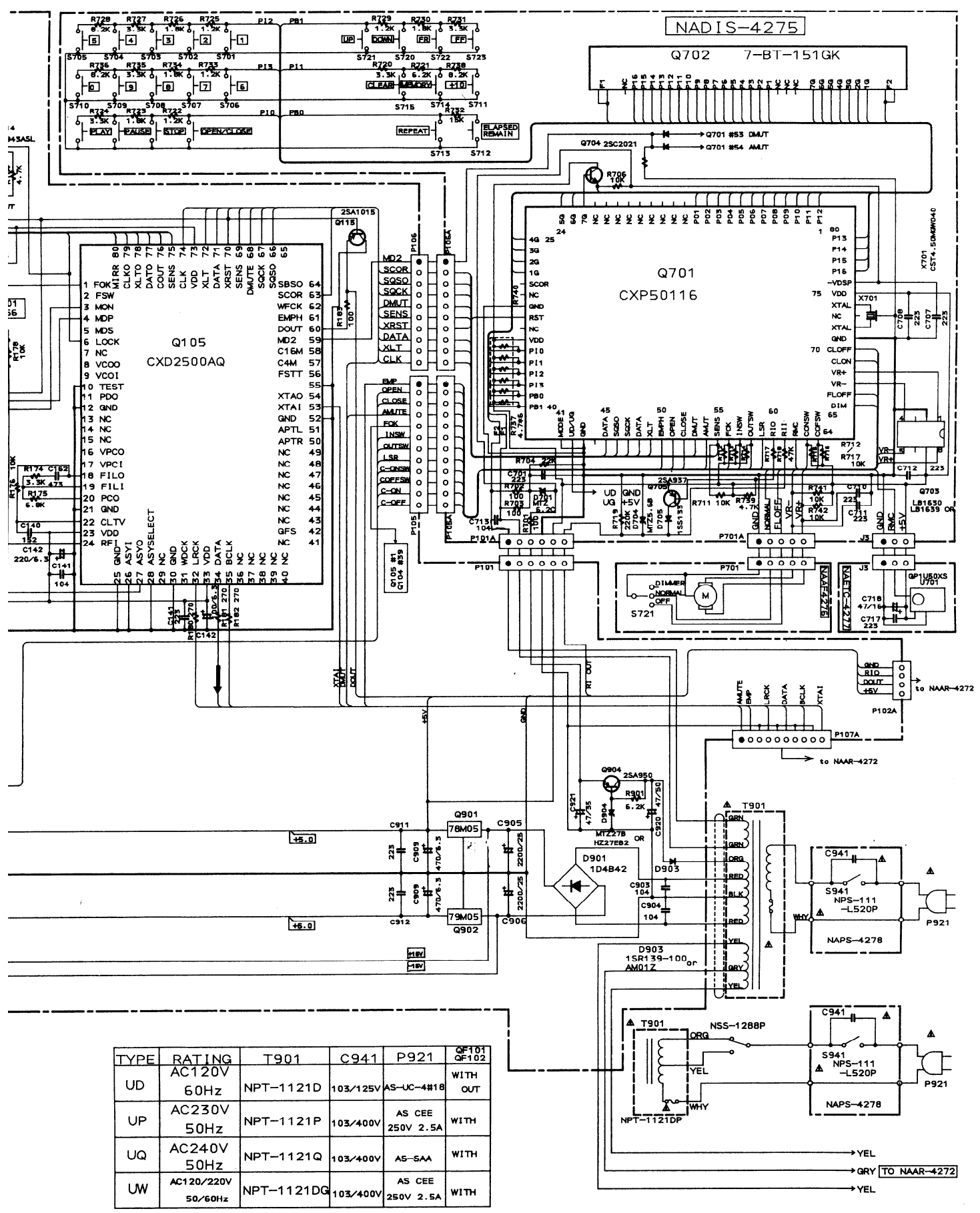

SCHEMATIC DIAGRAM

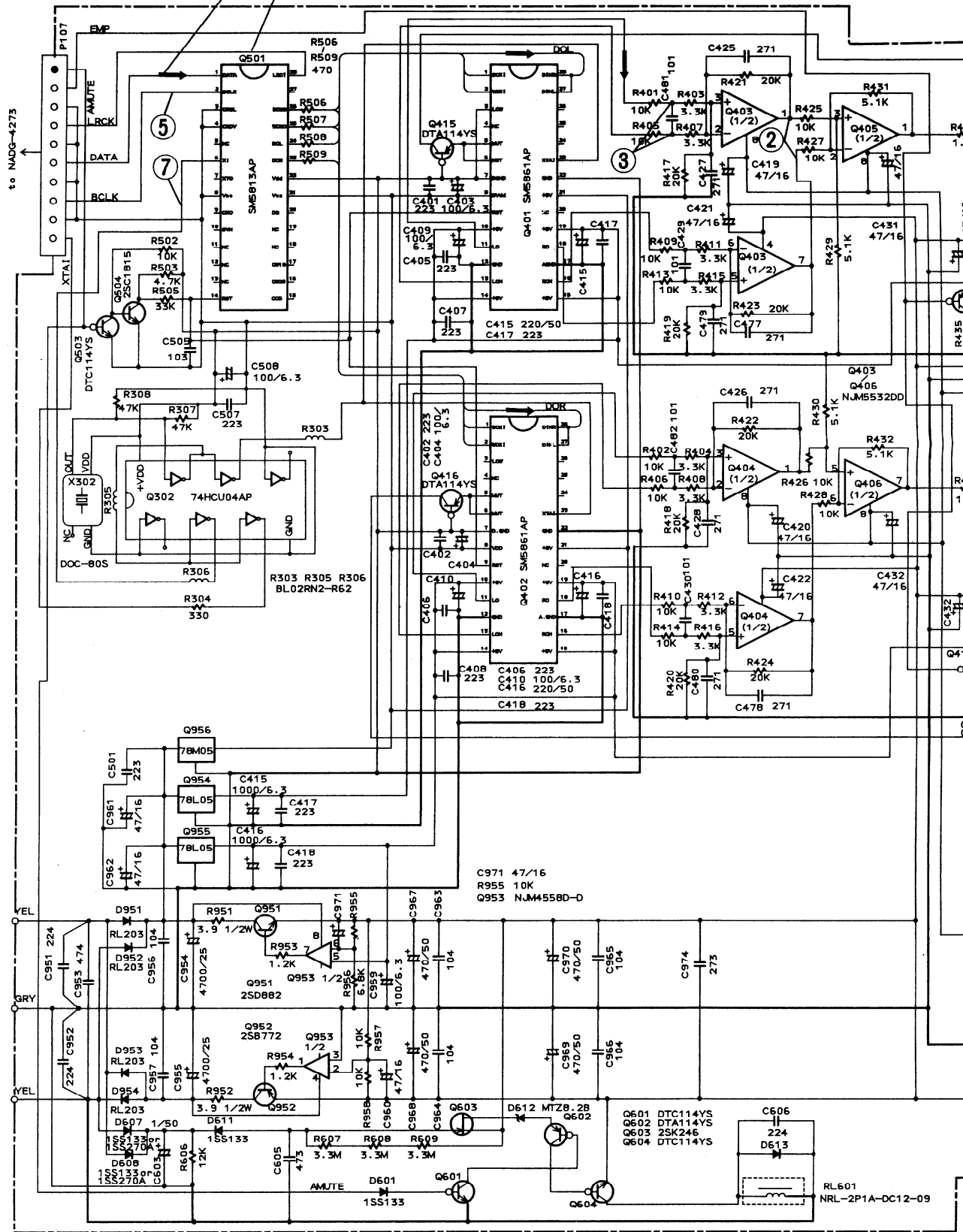

A
B
C
D
E
F

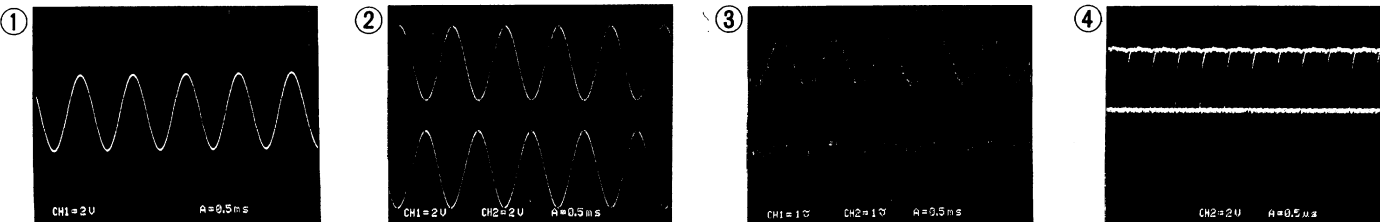

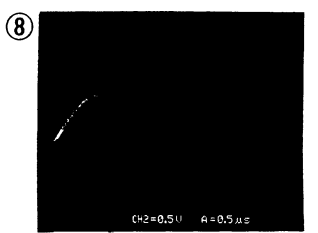
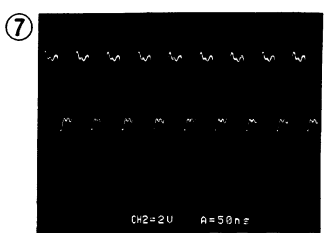
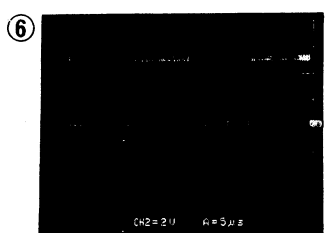
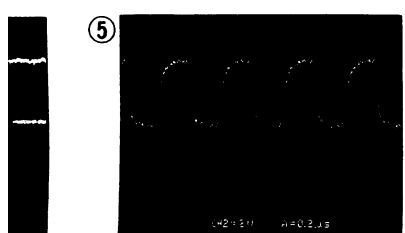
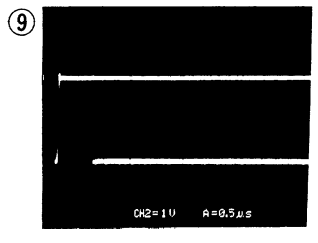
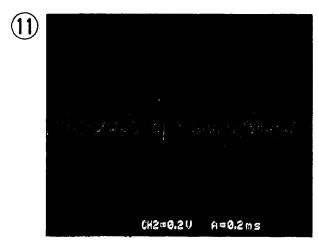
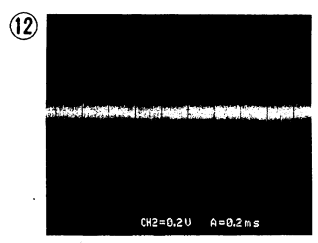
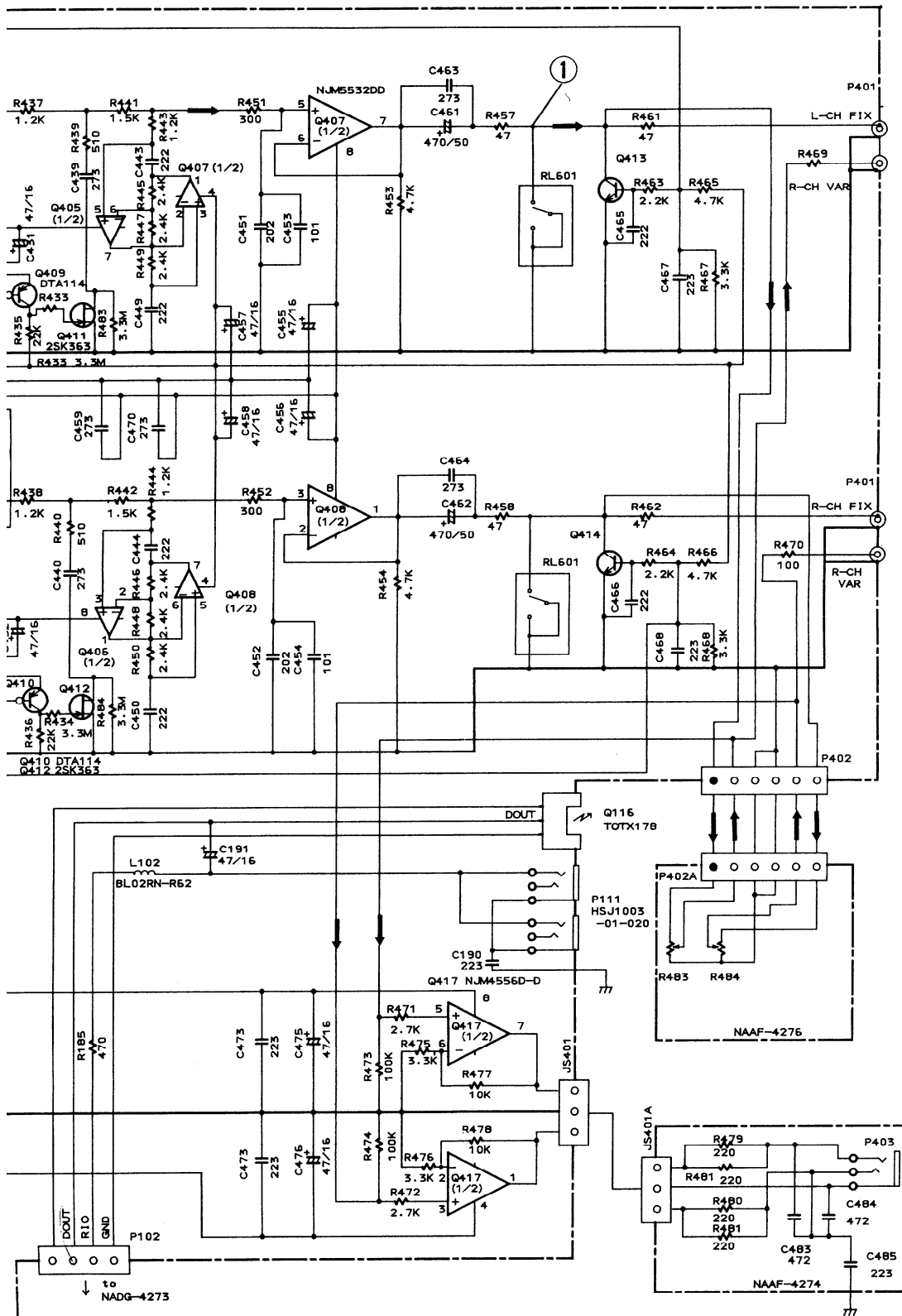

SCHEMATIC DIAGRAM

A
B
C
D
E
F

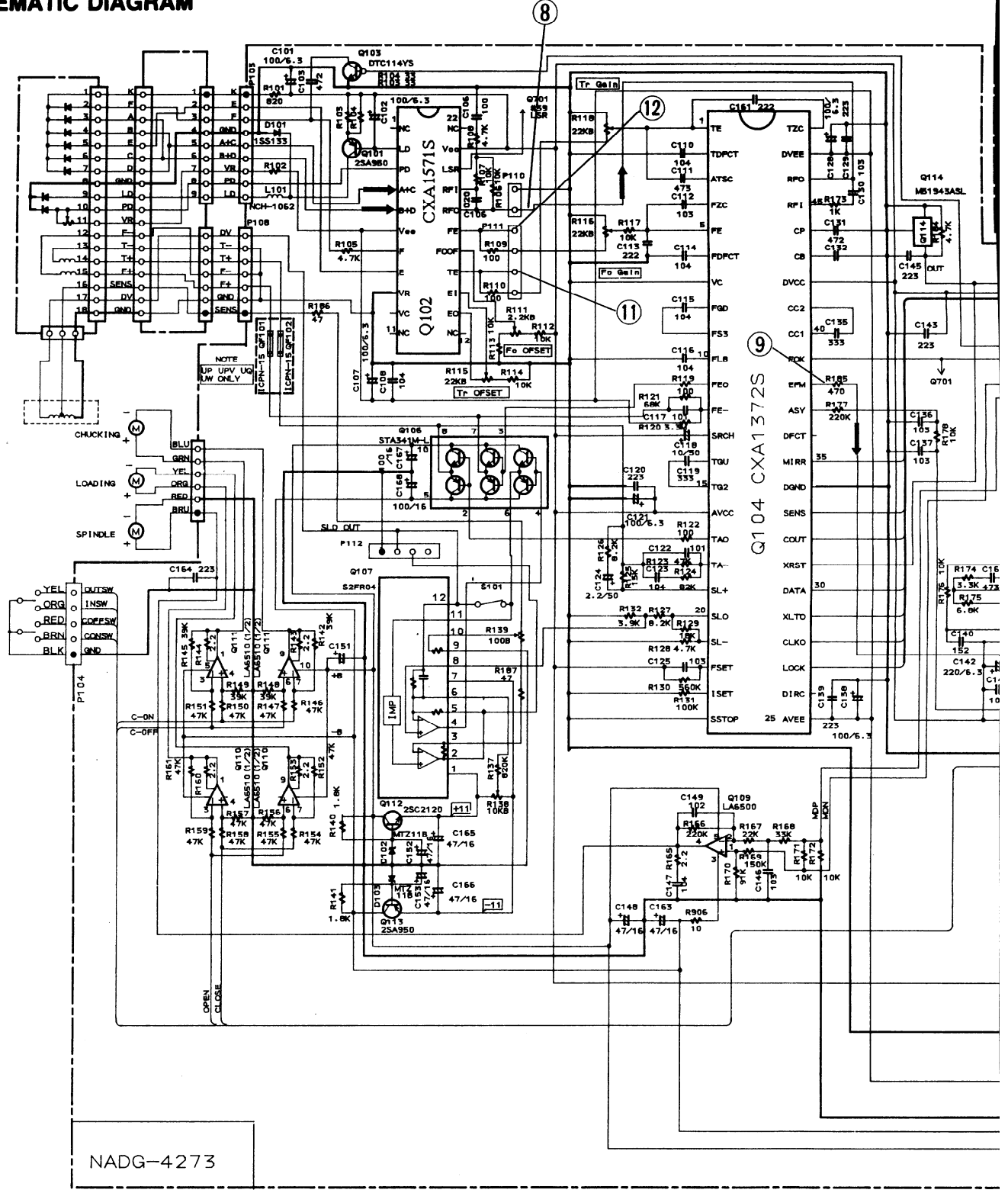

NADG-4273

NOTE

- THE COMPONENTS IDENTIFIED BY MARK Δ ARE CRITICAL FOR SAFETY. REPLACE ONLY WITH PART NUMBER SPECIFIED.
- VOLTAGE (MEASURED WITH VOLTMETER) C1 IS DC VOLTAGE, (NO INPUT SIGNAL)
- ALL PNP TRANSISTORS ARE EQUIVALENT TO 2SA1015-GR UNLESS OTHERWISE NOTED.
- ALL NPN TRANSISTORS ARE EQUIVALENT TO 2SC1815-GR UNLESS OTHERWISE NOTED.
- ALL DIODES ARE EQUIVALENT TO 1SS133 UNLESS OTHERWISE NOTED.
- ELECTROLYTIC CAPACITORS (E) ARE IN μ F/VV.
- ALL CAPACITORS ARE IN pF/50V UNLESS OTHERWISE NOTED.
- EXJ3pF-030, 33pF-330, 330pF-331, 0, 033 μ F-333
- ALL RESISTORS ARE IN OHMS 1/4 WATTS UNLESS OTHERWISE NOTED.
- THE THICK LINES IN PC BOARD ARE THE PRINTING SIDE OF THE PARTS.
- EXCEPT PRINTING SIDE
- CIRCUIT IS SUBJECT TO CHANGE FOR IMPROVEMENT.

TYPE	RATING	T901	C941	P921	Q102	T902
UD	AC120V 60Hz	NPT-1123D	103/ 125V	AS-UC- #18	WITH OUT	NPT-1124D
UP	AC230V 50Hz	NPT-1123P	103/ 400V	AS CEE 250V2.5A	WITH	NPT-1124P
UQ	AC240V 50Hz	NPT-1123Q	103/ 400V		WITH	NPT-1124Q
LW	AC120/220V 50/60Hz	NPT-1123DG	103/ 400V	AS CEE 250V2.5A	WITH	NPT-1124DG

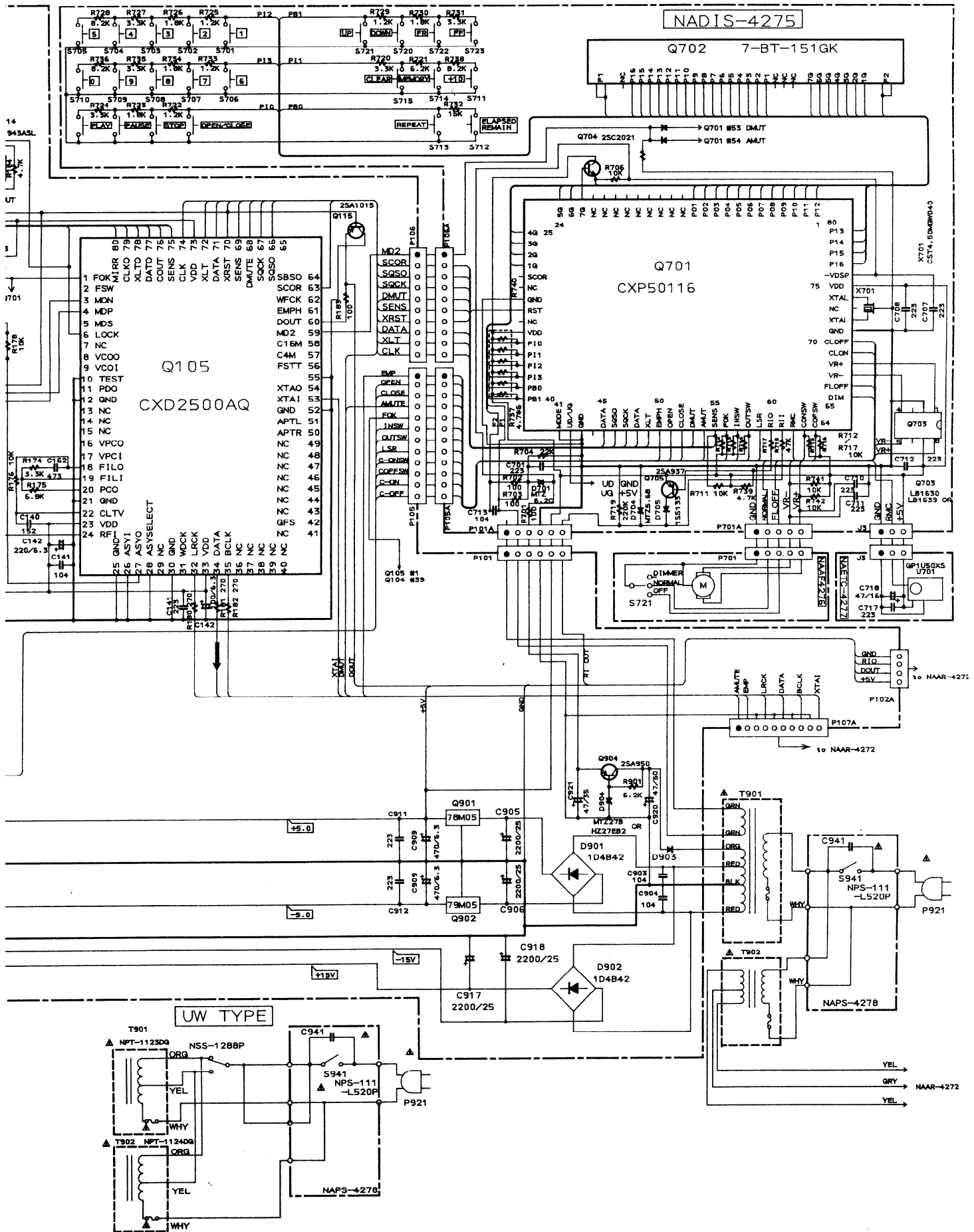

PACKING VIEW

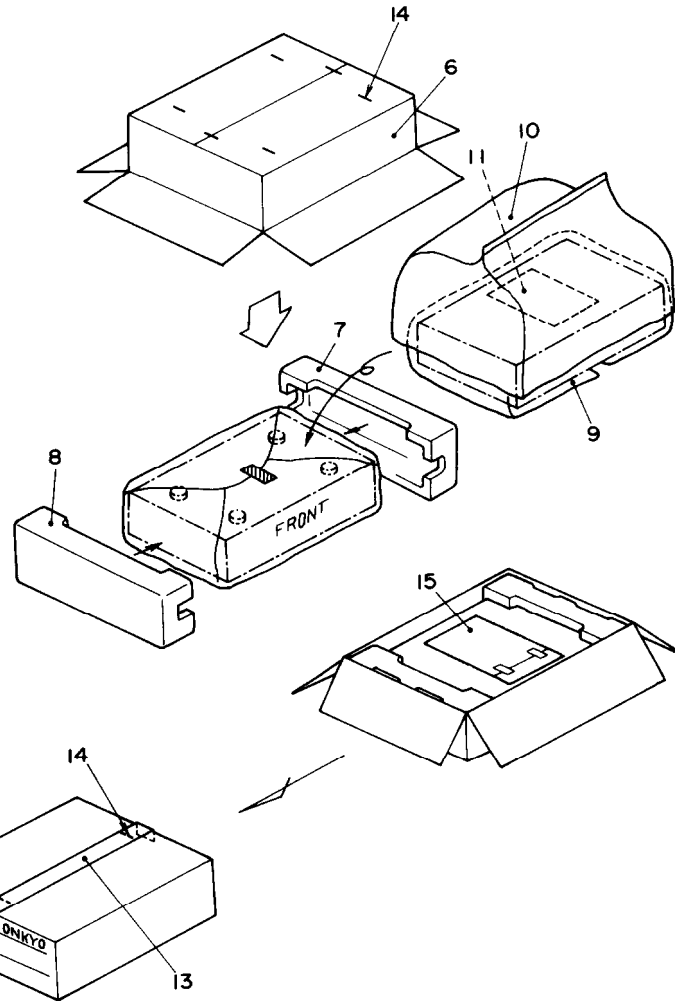
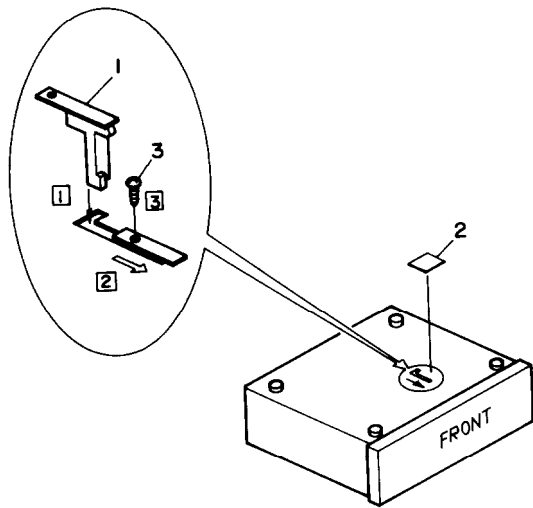

MODEL DX-706

MODEL DX-708

REF.NO.	PART NO.	DESCRIPTION
1	29335034A	Lock lever
2	29361360	Label
3	834430088	3TTS+8B(BC),Self-tapping screw
6	29052293	Master carton box
	29052305	Master carton box <S>
7	29091518A	Pad L
8	29091519A	Pad R
9	29095012-1	Protection sheet
10	29100105	620×550mm,Styrene bag
11	29355180	Caution sheet
13	29110071	Damplon tape
14	282301	Sealing hook
15	Accessory bag ass'y	
	2010098A	Connection cord
	2010200	Cord RI
	24140217A	RC-217C,Remote control transmitter
	3010054	UM-3,Two batteries
	29100097	350×250mm,Styrene bag
	29341661	Instruction manual <D>
	29341663	Instruction manual <P/W>
	29365019A	Warranty card <N>
	29365024A	Warranty card <F>
	29100107	Styrene bag for warranty card <F>
	29358002J	Service station list <N>
	25055040	CV-K-2,Conversion plug <W>

REF.NO.	PART NO.	DESCRIPTION
1	29335034A	Lock lever
2	29361360	Label
3	834430088	3TTS+8B(BC),Self-tapping screw
6	29052299	Master carton box
7	29091518A	Pad L
8	29091519A	Pad R
9	29095012-1	Protection sheet
10	29100105	620×550mm,Styrene bag
11	29355180	Caution sheet
13	29110071	Damplon tape
14	282301	Sealing hook
15	Accessory bag ass'y	
	2010238	Connection cord
	2010200	Cord RI
	24140218A	RC-218C,Remote control transmitter
	3010054	UM-3,Two batteries
	29100097	350×250mm,Styrene bag
	29341661	Instruction manual <D>
	29341663	Instruction manual <P/W>
	29365019A	Warranty card <N>
	29365024A	Warranty card <F>
	29100107	Styrene bag for warranty card <F>
	29358002J	Service station list <N>
	25055040	CV-K-2,Conversion plug <W>

- ① . Insert the lock lever into the hole on the bottom board as shown left.
- ② . Move the lock lever to the arrow mark.
- ③ . Tighten the screw to secure the lock lever with

NOTE:<D> : Only 120V models
<P> : Only 230V/240V models
<W> : Only Worldwide model
<N> : Only U.S.A. model
<F> : Only French model
<S> : Only Silver model
 : Only black model

ONKYO CORPORATION

International Division: Onarimon Yusen Bldg., 23-5, 3-chome, Nishi-Sinbashi, Minato-ku, Tokyo, Japa
Telex: 2423551 ONKYO J. Phone: 03-432-6981

ONKYO U.S.A. CORPORATION

200 Williams Drive, Ramsey, N.J. 07446 Tel. 201-825-7950

ONKYO DEUTSCHLAND GMBH, ELECTRONICS

8034 München-Germering, Industriestrasse 18 West Germany. Fax: 49-89-849-3226 Telefon: (089)-84-3071

ONKYO Europe GmbH

Hellersbergstrasse 4, 4040 Neuss WEST GERMANY
Tel: 02101 12 00 75 Fax 02101 10 33 06