

ONKYO® SERVICE MANUAL

COMPACT DISC PLAYER MODEL DX-750



Black model

BMP	230V AC, 50Hz
BMW	120/220V AC, 50/60Hz

SAFETY-RELATED COMPONENT WARNING!!

COMPONENTS IDENTIFIED BY MARK  ON THE SCHEMATIC DIAGRAM AND IN THE PARTS LIST ARE CRITICAL FOR RISK OF FIRE AND ELECTRIC SHOCK. REPLACE THESE COMPONENTS WITH ONKYO PARTS WHOSE PARTS NUMBERS APPEAR AS SHOWN IN THIS MANUAL.

MAKE LEAKAGE-CURRENT OR RESISTANCE MEASUREMENTS TO DETERMINE THAT EXPOSED PARTS ARE ACCEPTABLY INSULATED FROM THE SUPPLY CIRCUIT BEFORE RETURNING THE APPLIANCE TO THE CUSTOMER.

SPECIFICATIONS

Signal readout system:	Optical non-contact
Reading rotation:	About 500 – 200 r.p.m. (constant linear velocity)
Linear velocity:	1.2 – 1.4 m/s
Error correction system:	Cross Interleave Reed Solomon code
D/A converter:	1 bit PWM ACCUPULSE D/A CONVERTER
Sampling frequency:	352.8 kHz (Eight-times oversampling)
Number of channels:	2 (stereo)
Frequency response:	5 Hz – 20 kHz
Total harmonic distortion:	0.004% (at 1 kHz)
Dynamic range:	96 dB
Signal to noise ratio:	100 dB
Channel separation:	90 dB (at 1 kHz)
Wow and Flutter:	Below threshold of measurability
Output level:	2 volts r.m.s.
Power consumption:	11 watts
Dimensions (W × H × D):	455 × 120 × 308 mm
Weight:	5.1 kg, 11.2 lbs.

Specifications and external appearance are subject to change without notice because of product improvements.

ONKYO
AUDIO COMPONENTS

TABLE OF CONTENTS

Specifications.....	1
Service procedures.....	2
Caution on replacement of optical pickup.....	2
Protection of eyes from laser beam during servicing.....	3
Laser warning labels.....	3
Exploded view.....	4
Parts list.....	5
Mechanism-exploded view.....	6
Removement of tray ass'y.....	7
Microprocessor connection diagram.....	8
Microprocessor terminal description.....	9
IC block diagrams and descriptions.....	10
Disassembling procedures.....	15
Block diagram.....	16
Adjustment procedures.....	17
Printed circuit board view from bottom side.....	19
Schematic diagram.....	21
Printed circuit board-parts list.....	23
Schematic diagram mechanism block.....	25
Packing view.....	26

SERVICE PROCEDURES

1. Safety-check out

After correcting the original service problem, perform the following safety check before releasing the set to the customer:

Connect the insulating-resistance tester between the plug of power supply cord and chassis.

Specifications: More than 10Mohm at 500V.

2. Voltage Selector (Back panel)

Worldwide models are equipped with a voltage selector to conform with local power supplies. Be sure to set this switch to match the voltage of the power supply in user's area before turning the power switch on.

Voltage is changed by sliding the groove in the switch with a screw driver to the right or left.

Confirm that the switch has been moved all the way to the right or left before turning the power switch on.

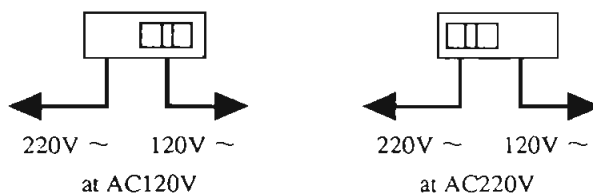

CAUTION ON REPLACEMENT OF OPTICAL PICKUP

The laser diode in the optical pickup block is so sensitive to static electricity, surge current and etc, that the components are liable to be broken down or its reliability remarkably deteriorated.

During repair, carefully take the following precautions. (The following precautions are included in the service parts.)

PRECAUTIONS

1. Ground for the work-desk.

Place a conductive sheet such as a sheet of copper (with impedance lower than 10MΩ) on the work-desk and place the set on the conductive sheet so that the chassis.

2. Grounding for the test equipment and tools.

Test equipments and toolings should be grounded in order that their ground level is the same the ground of the power source.

3. Grounding for the human body.

Be sure to put on a wrist-strap for grounding whose other end is grounded.

Be particularly careful when the workers wear synthetic fiber clothes, or air is dry.

4. Select a soldering iron that permits no leakage and have the tip of the iron well-grounded.

5. Do not check the laser diode terminals with the probe of a circuit tester or oscilloscope.

PROTECTION OF EYES FROM LASER BEAM DURING SERVICING

This set employs a laser. Therefore, be sure to follow carefully the instructions below when servicing.

WARNING!!

WHEN SERVICING, DO NOT APPROACH THE LASER EXIT WITH THE EYE TOO CLOSELY. IN CASE IT IS NECESSARY TO CONFIRM LASER BEAM EMISSION, BE SURE TO OBSERVE FROM A DISTANCE OF MORE THAN 30cm FROM THE SURFACE OF THE OBJECTIVE LENS ON THE OPTICAL PICK-UP BLOCK.

LASER WARNING LABELS

The label shown below are affixed.

1. Warning label

This label is located on the chassis.

(A) **DANGER** —INVISIBLE LASER RADIATION WHEN OPEN AND INTERLOCK FAILED OR DEFEATED. AVOID DIRECT EXPOSURE TO BEAM.

CAUTION —HAZARDOUS LASER AND ELECTROMAGNETIC RADIATION WHEN OPEN AND INTERLOCK DEFEATED.

ATTENTION —RAYONNEMENT LASER ET ELECTROMAGNETIQUE DANGEREUX SI OUVERT AVEC L'ECLenchement DE SECURITE ANNULE.

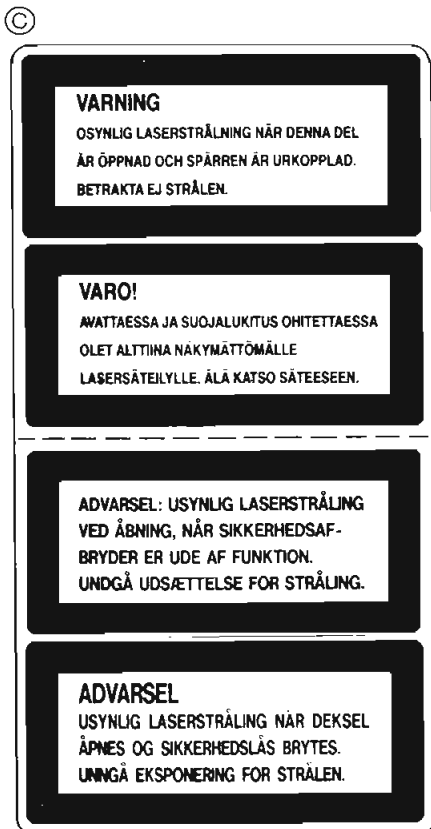
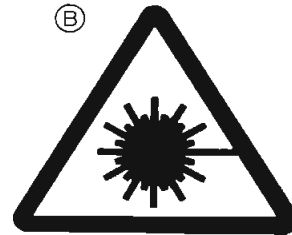

- (A) : Danger label
(C) : Only 230V model except germany model

Laser Diode Properties

- Material: GaAS/GaAlAs
- Wavelength: 780nm
- Emission Duration: continuous
- Laser output: max. 0.5mW*

*This output is the value measured at a distance about 1.8mm from the objective lens surface on the Optical Pick-up Block.

2. Class 1 label

This label is located on the rear panel.



LUOKAN 1 LASERLAITE
KLASS 1 LASER APPARAT

ADVARSEL

Denna mækning er anbragt på apparatets højre side og indikerer, at apparatet arbejder med laserstråler af klasse 1, hvilket betyder, at der anvendes laserstråler af svageste klasse, og at man ikke på apparatets yderside kan blive udsat for utilsadelig kraftig stråling.

APPARATET BØ/R KUN ÅBNES AF FAGFOLK MED SE RLIGT KENDSKAB TIL APPARATER MED LASERSTRÅLERI

Indvendigt i apparatet er anbragt den her gengivne advarselmærkning, som advarer imod at foretage sådne indgreb i apparatet, at man kan komme til at udsætte sig for laserstråling.

VAROITUSI LAITTEEN KAYTTAMINEN MUULLA KUIN TASSA KAYTTOOHJEESSA MAINTULLA TAVALLA SAATTAA ALTISTAA KAYTTAJAN TURVALLISUUSLUOKAN 1 YLITTAVALLE NÄKYMÄTTÖMÄLLE LASERSÄTEILYLLE.

EXPLODED VIEW

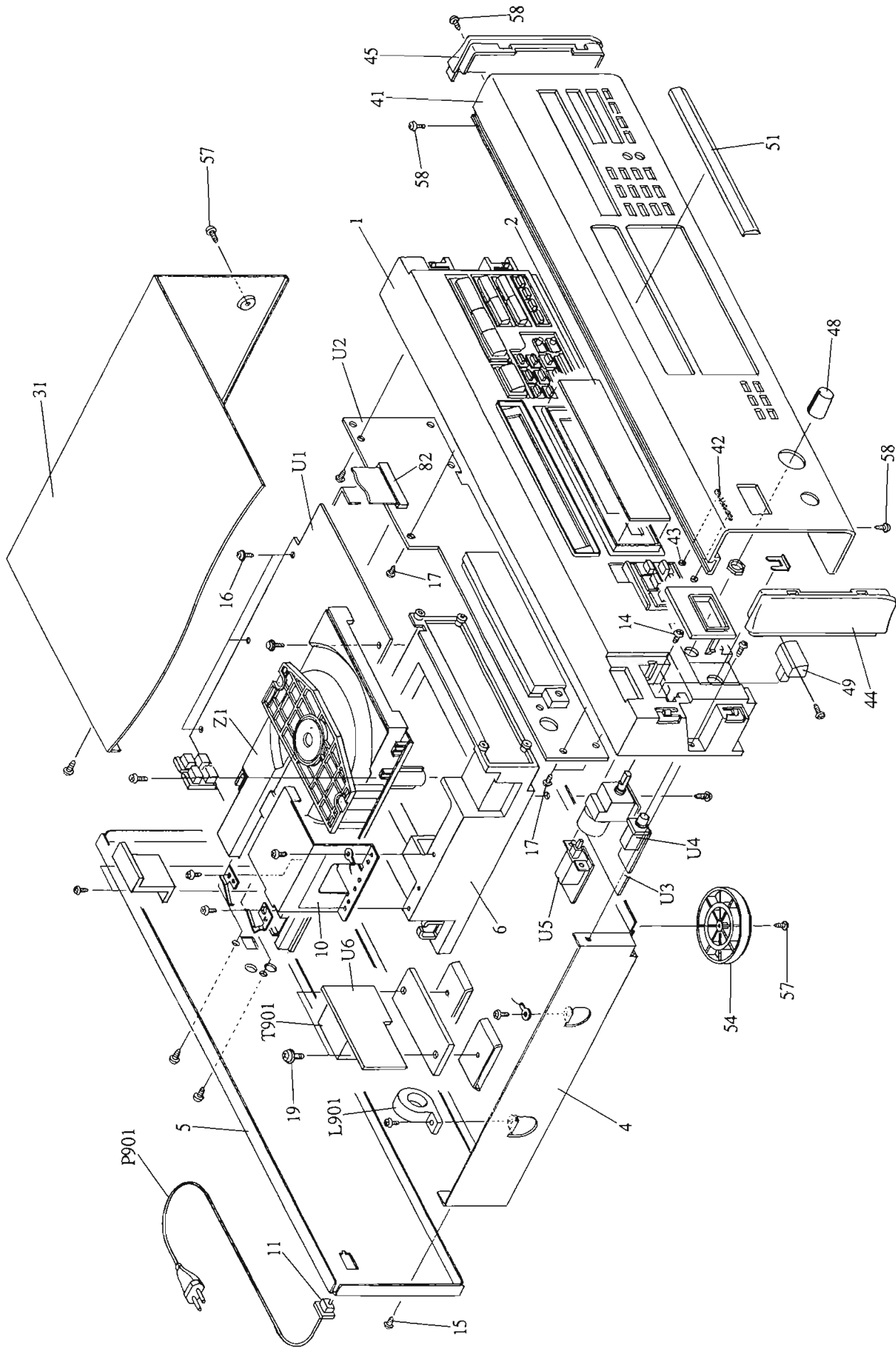

PARTS LIST

REF.NO.	PART NO.	DESCRIPTION	REF.NO.	PART NO.	DESCRIPTION
1	27110776AY	Front bracket ass'y	82	2047371512	NCFC7-371512,Flexible flat cable
2	28191662Y	Clear plate	83	2047221012	NCFC7-221012,Flexible flat cable
4	27100227CY	Chassis	L901	230910	△ ESD-R-25DB,Core
5	27121772Y	Rear panel <P>	P901	253175 or	△ AS-CEE,
	27121774Y	Rear panel <W>	253164	△	Power supply cord
6	27190928AY	Holder M	T901	2300776Y	△ NPT-1138P,Power transformer <P>
10	27141618Y	Retainer M		2300777Y	△ NPT-1138DG,Power transformer <W>
11	27300750	△ Bushing	U1	1H226502-1A	NAAR-4802-1A,Main circuit pc board ass'y
12	27255004	CS-1U,Clamp	U2	1H226503-1	NADIS-4803-1,Display circuit pc board ass'y
13	27301396	HL-28D,Clamp	U3	1H226504-1	NAAF-4804-1,Headphone amplifier pc board ass'y
14	82143006	3P+6FN(BC),Pan head screw	U4	1H226505-1	NAAF-4805-1,Headphone terminal pc board ass'y
15	834430088	3TTS+8B(BC),Self-tapping screw	U5	1H226506-1	NAPS-4806-1,Power switch pc board ass'y <P>
16	831130088	3TTW+8B,Self-tapping screw		1H226506-1A	NAPS-4806-1A,Power switch pc board ass'y <W>
17	833430080	3TTP+8P(BC),Self-tapping screw	U6	1H226507-1	NAPS-4807-1,Power transformer pc board ass'y
18	831430100	3TTW+10P(BC),Self-tapping screw	U7	1H226508-1	NASW-4808-1,Voltage selector switch
19	830440109	4TTC+10C(BC),Self-tapping screw		Z1	pc board ass'y <W>
20	834430108	3TTS+10B(BC),Self-tapping screw			NCD-131S,CD mechanism ass'y
31	28184479	Top cover			
32	28140680	0.5 X 8 X 180,Cushion			
41	27211530AY	Front panel			
42	28135199Y	Badge			
43	8910301	Ring CS			
44	28125248Y	End cap L			
45	28125249Y	End cap R			
48	28324845	Knob,level			
49	28324140Y	Knob,power			
51	28148274	Door			
54	27175254AY	Leg			
57	834430088	3TTS+8B(BC),Self-tapping screw			
58	833430080	3TTP+8P(BC),Self-tapping screw			
71	29361581Y	Label			
72	29360687	Label,CLASS1			
81	260208	Binder			

NOTE: <P>:230V model only

<W>:Worldwide model only

NOTE: THE COMPONENTS IDENTIFIED BY MARK △ ARE CRITICAL FOR RISK OF FIRE AND ELECTRIC SHOCK. REPLACE ONLY WITH PART NUMBER SPECIFIED.

MECHANISM-EXPLODED VIEW

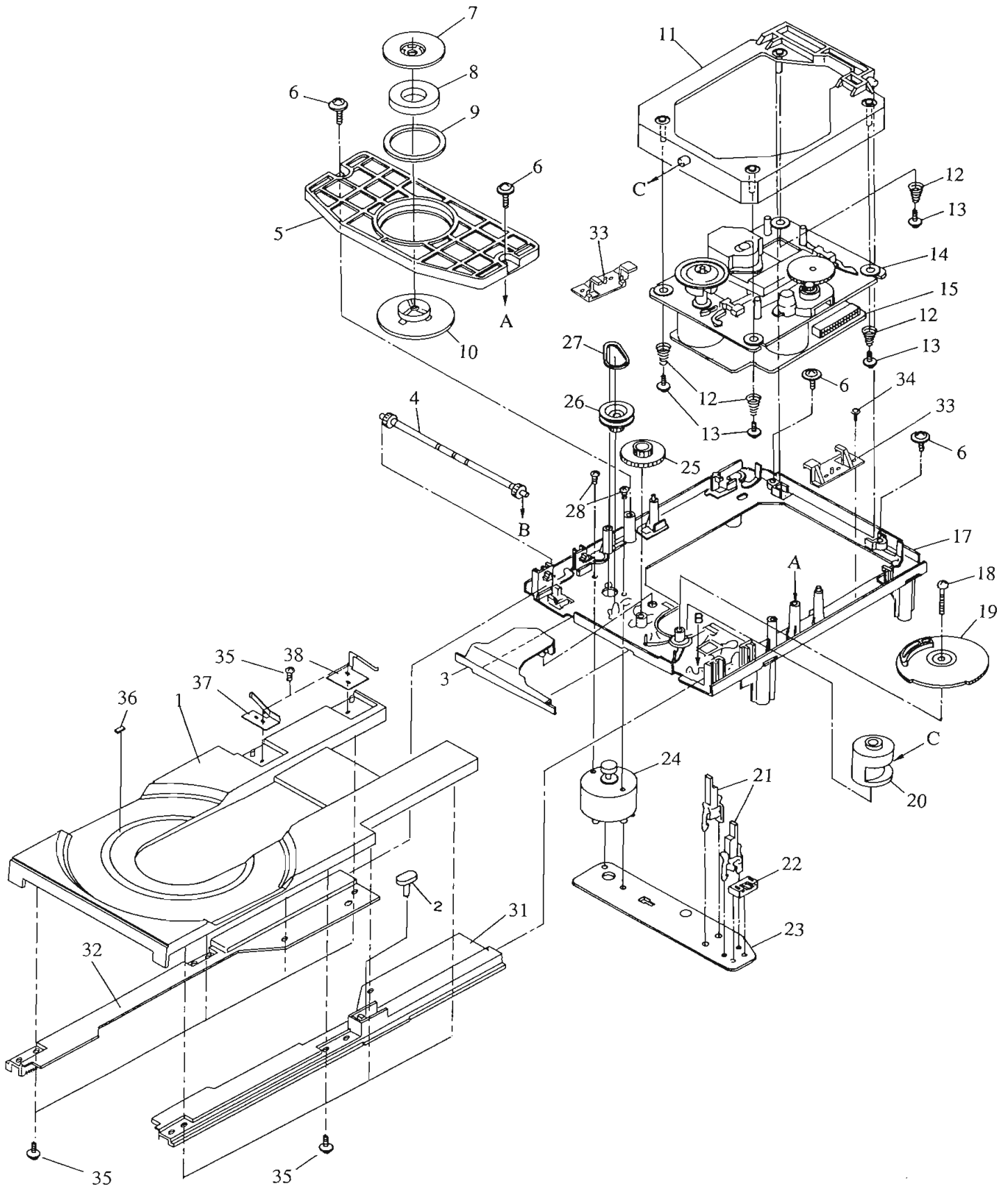

DRIVE UNIT

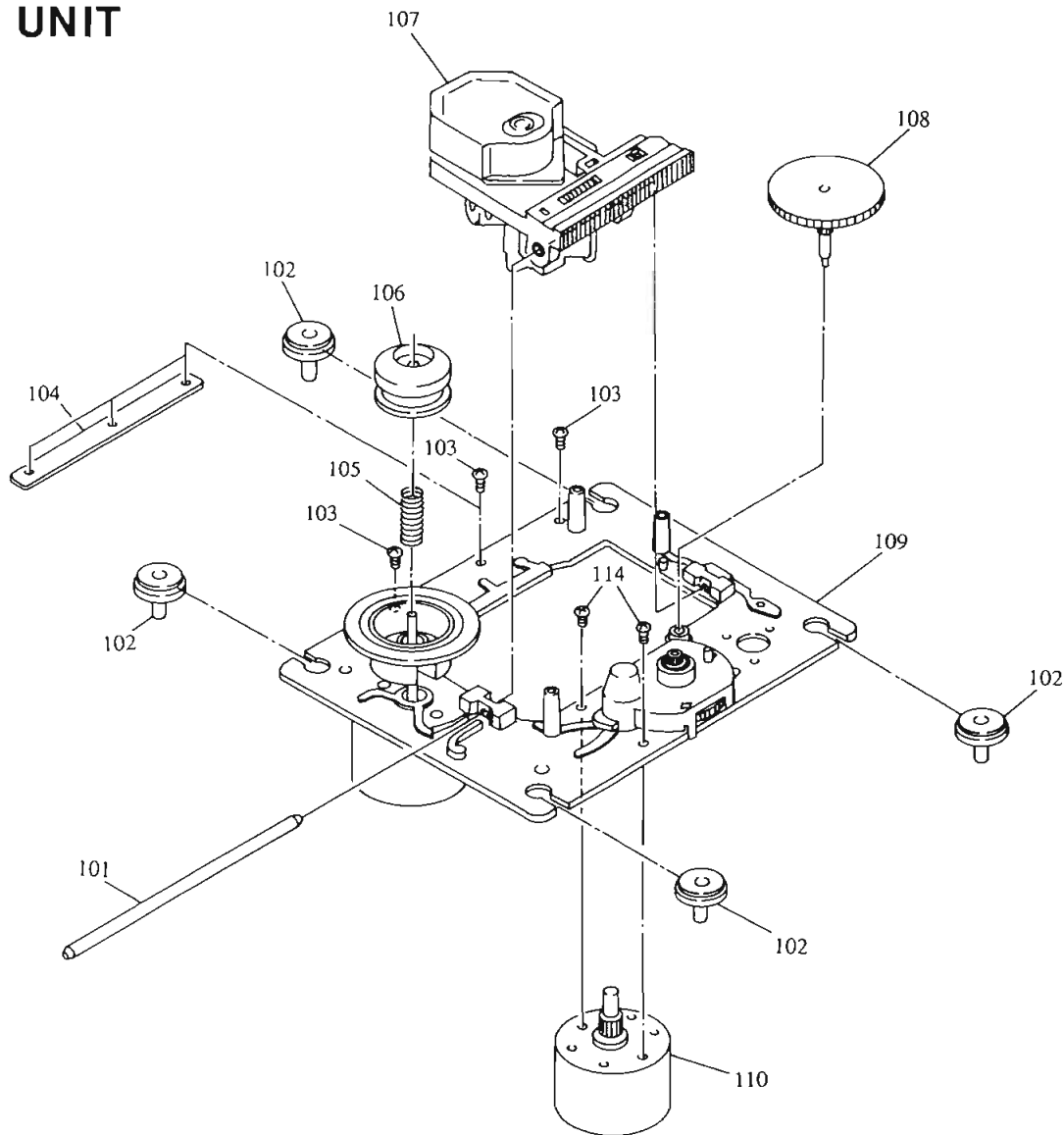

PARTS LIST

REF.NO.	PART NO.	DESCRIPTION	REF.NO.	PART NO.	DESCRIPTION
1	24840053	Tray	25	24810022	Middle gear
2		Stopper	26	24810025	Loading plate
3	24822014	Gear cover	27	24816008	Belt
4	24810020	Tray gear	28		2.6B+2.5F, Binding screw
5	24840061	Chucking plate	31	24840055A	Rack R
6		2.6TTW+7B, Self-tapping screw	32	24840054B	Rack L
7	24830003	Chucking yoke	33	24840056A	Holder
8	24832004	Magnet	34	833130087	3TTP+8S, Self-tapping screw
9	24836013	Damper	35	834426068	2.6TTS+6B(BC), Self-tapping screw
10	24810024	Chucking plate	36	24836013-1Y	Cushion
11	24802012	Sub-chassis	37	24820021Y	Spring F
12	24820023	Spring	38	24820022Y	Spring R
13	24840062	Screw with washer	101	24828006	Sled shaft S
14		KSM-2401, Pickup drive unit	102	24836014	Insulator S
15	24840075	CD servo pcb ass'y	103	24840068	2×5, Special screw
17	24802013	Main chassis	104	24822015	Plate S
18		2.6TTW+16B, Self-tapping screw	105	24820024	Spring
19	24810021	Drive gear	106	24824003	Center ring
20	24840063	Control cam	107	24110011	KSS-240A, Optical pickup
21	24840064	Leafswitch	108	24810023	Wheel
22	25055369	NPLG-5P352, Plug	109	24802014	Chassis
23	24840066	Loading motor pc board	110	24804012	Motor gear
24	24840067	Loading motor	114	82112003	2P+3FN, Pan head screw

MICROPROCESSOR CONNECTION DIAGRAM

CXP50116-527 (Microprocessor)

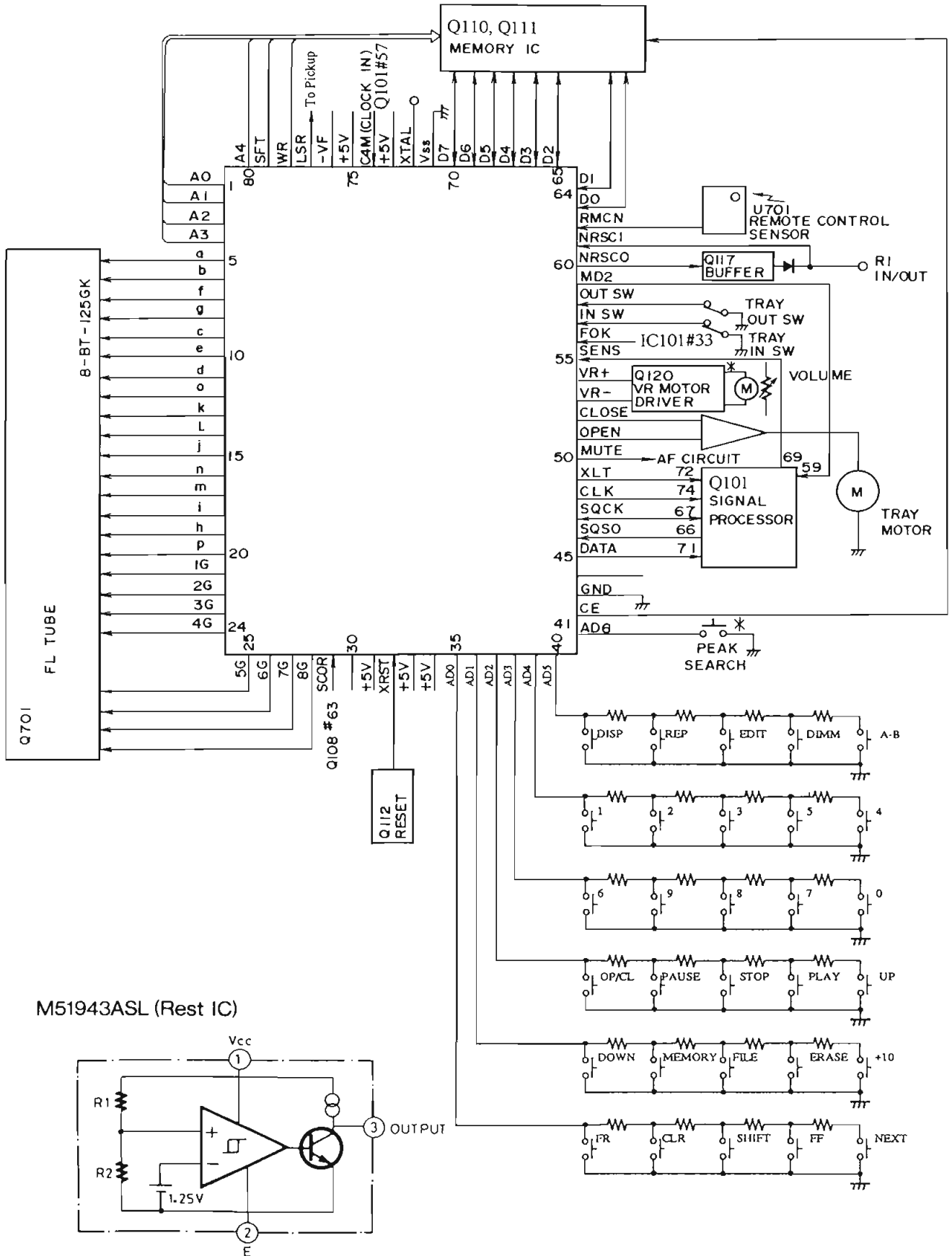

Pin No.	Symbol	Description
1 ~ 4	A0 ~ A3	Music file address signal.
5 ~ 20	a ~ p	Fluorescent indicator tube segment drive output terminals.
21 ~ 28	1G ~ 8G	Fluorescent indicator tube grid drive output terminals.
29	SCOR	Synchronizing signal detection input terminal of sub code frame.
31	5V	
32	XRST	Reset input terminal. Reset at the low level.
33,34	5V	
35 ~ 41	AD0 ~ AD6	AD input terminal. Connect to the operation key.
42	CE	Chip enable terminal.
43	GND	
45	DATA	Serial data output terminal.
46	SQSO	Subcode Q input terminal.
47	SQCK	Subcode Q read clock input/output terminal.
48	CLK	Serial data transmission clock output terminal.
49	XLT	Command execution output terminal.
50	MUTE	Muting ON/OFF control output terminal. ON at the high level.
51	OPEN	Tray open control output terminal. Open at the low level.
52	CLOSE	Tray close control output terminal. Close at the low level.
53	VR-	Volume control output.
54	VR+	Volume control output.
55	SENS	Interface of signal processor and microprocessor ICs.
56	FOK	Focus OK input terminal. Focus OK at the high level.
57	INSW	Tray close detection input terminal.
58	OUTSW	Tray open detection input terminal.
59	MD2	Digital output control output.
60	NRSCO	Remote control signal (RI signal) output terminal.
61	NRSCI	Remote control signal (RI signal) input terminal.
62	RMCN	Remote control signal input terminal.
63 ~ 70	D0 ~ D7	Music file data signal.
71	Vss	Ground terminal.
72	XTAL	Clock output terminal.
73	5V	
74	C4M	System clock input terminal.
75	5V	
76	VF	Negative power supply terminal for fluorescent indicator tube.
77	LSR	Optical pickup control output terminal. On at the low level.
78	WR	Music file read/write control signal.
79	SFT	Music file shift signal. Control the serial data at the rise pulse.
80	A4	Music file address signal.

CXD2500AQ (Digital Signal Processor)

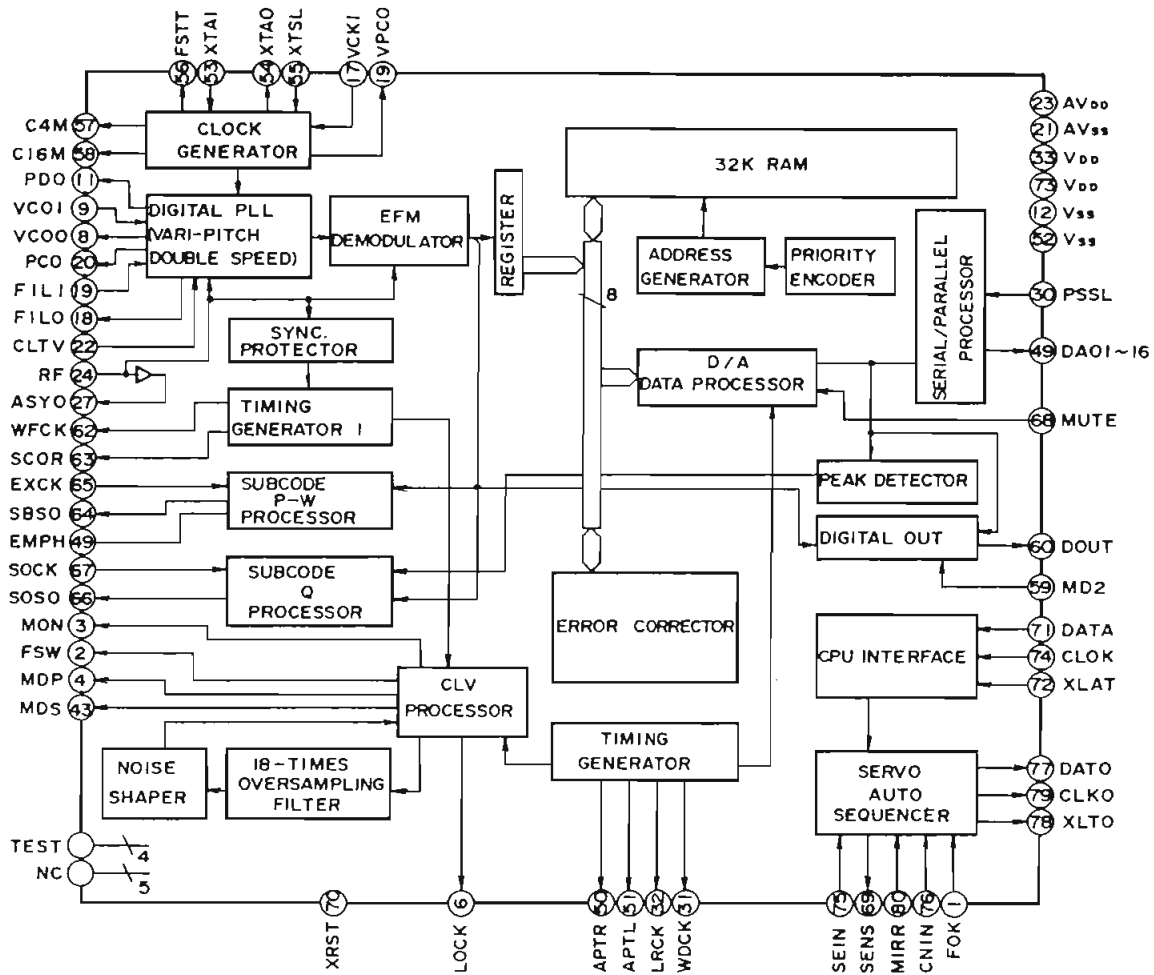

LB1639 (Volume Motor Drive)

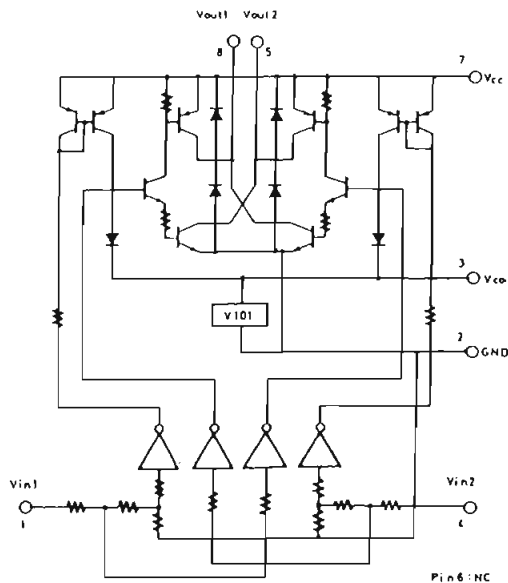

74HC164(8-bits Serial/Parallel Output Shift Register)

TRUTH TABLE

Inputs				Outputs			
Clear	Clock	A	B	QA	QB	QH
L	X	X	X	L	L	L
H	L	X	X	QA0	QB0	QH0
H	↑	H	H	H	QAn	QGn
H	↑	L	X	L	QAn	QGn
H	↑	X	L	L	QAn	QGn

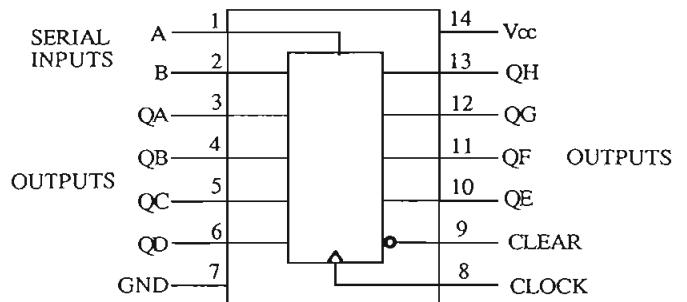

NO.	SYMBOL	I/O	DESCRIPTION
1	FOK	I	Foucs Ok input
2	FSW	O	Output filter changeover output for spindle motor
3	MON	O	Spindle motor control output
4	MDP	O	Spindle motor servo control
5	MDS	O	Spindle motor servo control
6	LOCK	O	H when GFS is the high level
7	NC		
8	VCOO	O	Oscillation circuit output for analog EFM PLL.
9	VCOI	I	Oscillation circuit input for analog EFM PLL. (8.6436MHz)
10	TEST	I	Test terminal
11	PDO	O	Charge pump output analog EFM PLL
12	Vss		Ground terminal
13-15	NC		
16	VPCO	O	PLL charge pump output for variable pitch
17	VCKI	I	Clock input for variable pitch from VCO (16.934MHz)
18	FILO	O	Filter output for master PLL.
19	FILI	I	Filter input for master PLL.
20	PCO	O	Charge pump output of master PLL
21	AVss		Analog ground
22	CLTV	I	VCO control voltage input for master
23	AVDD		Analog section power supply (+5V)
24	RF	I	EFM signal input
25	BIAS	I	Asymmetry circuit constant current input
26	ASYI	I	Asymmetry comparator voltage input
27	ASYO	O	EFM full swing output
28	ASYE	I	Asymmetry control circuit
29	NC		
30	PSSL	O	Audio data output mode changeover input Serial data at L and paraller data at H.
31	WDCK	I	D/A interface for 48 bits slot. Word clock $f=2F_s$.
32	LRCK	I	D/A interface for 48 bits slot. LR clock $f=F_s$.
33	VDD		Power supply terminal (+5V)
34-49			Data output terminals
			PSSL=1 PSSL=0
34	DA16	O	DA16 Serial data of 48 bits slot
35	DA15	O	DA15 Bit clock of 48 bits slot
36	DA14	O	DA14 Serial data of 64 bits slot
37	DA13	O	DA13 Bit clock of 68 bits slot
38	DA12	O	DA12 LR clock of 68 bits slot
39	DA11	O	DA11 GTOP output
40	DA10	O	DA10 XUGF output
41	DA09	O	DA09 XPLCK output

NO.	SYMBOL	I/O	DESCRIPTION
42	DA08	O	DA08 GFS output
43	DA07	O	DA07 RFCK output
44	DA06	O	DA06 C2P0 output
45	DA05	O	DA05 XRAOF output
46	DA04	O	DA04 MNT 3 output
47	DA03	O	DA03 MNT 2 output
48	DA02	O	DA02 MNT 1 output
49	DA01	O	DA01 MNT 0 output
50	APTR	O	Control output for aperture correction. H when R ch.
51	APTL	O	Control output for aperture correction. H when L ch.
52	Vss		Ground terminal
53	XTAI	I	Crystal oscillation circuit input of 16.9344MHz or 33.8688MHz input.
54	XTAO	O	Crystal oscillation circuit output of 16.9344MHz.
55	XTSL	I	Crystal selection input terminal. L when 16.9344MHz. H when 33.8688MHz.
56	FSTT	O	2/3 divided output of pins 53 and 54.
57	C4M	O	4.2336 MHz output
58	C16M	O	16.9344 MHz output
59	MD2	I	Digital output control input. On at high level.
60	DOUT	O	Digital output
61	EMPH	O	Emphasis control output. Active high.
62	WFCK	O	Write frame clock output
63	SCOR	O	Sub-code detection output. H when is detected SO or SI.
64	SBSO	O	Serial output of sub-code (P~W)
65	EXCK	I	Clock input for read out SQSO.
66	SQSO	O	Sub Q 80 bits, PCM peak, and level data 16 bits output.
67	SQCK	I	Clock input for read out SQSO
68	MUTE	O	Muting control output. Active H.
69	SENS		Sens output. Output to the microprocessor
70	XRST	I	System reset. Reset at the low level.
71	DATA	I	Serial data input from the microprocessor.
72	XLTA	I	Latch input from the microprocessor. Latch the serial data at the trailing.
73	VDD		Power supply treminal
74	CLOK	I	Serial data transfer clock input from microprocessor
75	SEIN	I	Sens input from SSP
76	CNCI	I	Track jump numbers count signal input
77	DATO	O	Serial data output to SSP
78	XLTO	O	Serial data latch output to SSP. Latch at trailing.
79	CLKO	O	Serial data transfer clock output to SSP.
80	MIRR	I	Mirror signal input

Note: SSP: IC101 CXA1372Q

M51943ASL (System reset)

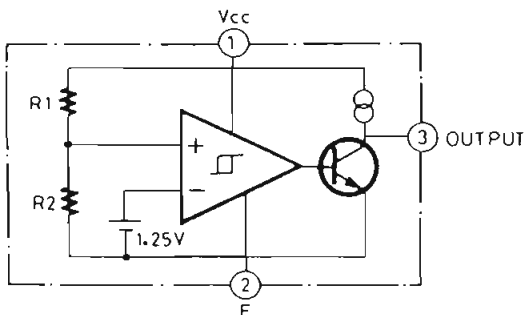

74HCU04P (Hex inverters)

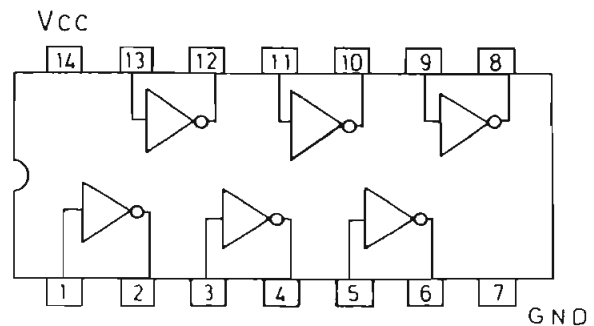

CXA1372Q (Servo Signal Processor)

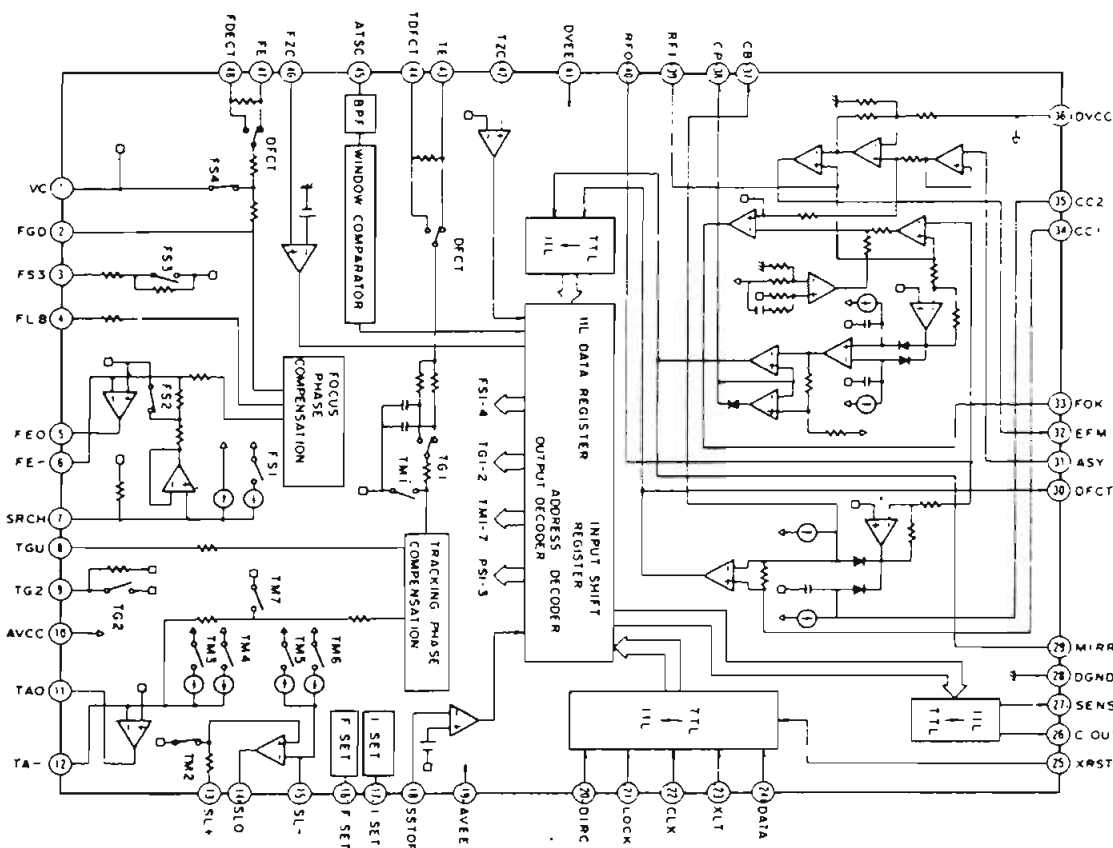

PIN NO.	SYMBOL	I/O	DESCIRPTION	PIN NO.	SYMBOL	I/O	DESCIRPTION
1	VC	I	Mid-point voltage input terminal.	23	XLT	I	Latch input terminal for microprocessor.
2	FGD	I	Connect the capacitor between FS3 and this pin when the high frequency gain focus servo is dropped.	24	DATA	I	Serial data input terminal for microprocessor.
3	FS3	I	Focus servo high frequency gain changeover input terminal.	25	XRST	I	Reset input terminal.Active low.
4	FLB	I	Input terminal for the low frequency boost of focus servo.	26	C.OUT	O	Signal output to count the track numbers.
5	FEO	O	Focus drive output terminal.	27	SENS	O	This terminal outputs FZC.and SSTOP to according comand from the microprocessor.
6	FE-	I	Inversion input terminal of focus amplifier.	29	MIRR	O	Mirror comparator output terminal.
7	SRCH	I	Time constant terminal to make the focus search waveform.	30	DFCT	O	Defect comparator output terminal.
8	TGU	I	Tracking high frequency changeover input terminal.	31	ASY	I	Auto asymmetry control input terminal.
11	TAO	O	Tracking drive output terminal.	32	EFM	O	EFM comparator output terminal.
12	TA-	I	Inversion input terminal of tracking amplifier.	33	FOK	O	Focus OK comparator output terminal.
13	SL+	I	No-inversion input terminal of sled amplifier.	34	CC1	O	Defect bottom hold output terminal.
14	SLO	O	Sled drive output terminal.	35	CC2	I	Defect bottom hold input terminal from CC1.
15	SL-	I	Inversion input terminal of sled amplifier.	37	CB	I	Defect bottom hold capacitor connection terminal.
16	FSET	I	Peak setting input of phase correction of focus tracking.	38	CP	I	Mirror hold capacitor connection terminal.
17	ISET	I	This terminal is flowed the current so that the focus search,tarcking jump,and sled kick height is decided.	39	RFI	I	RF summing amplifier input terminal.
18	SSTOP	I	Inner switch selection input terminal.	40	RFO	O	RF summing amplifier output terminal.
20	DIRC	I	This terminal is used when track jump.	42	TZC	I	Tracking zero-cross comparator input terminal.
21	LOCK	I	The sled runaway prevention circuit operates at the low level.	43	TE	I	Tracking error input terminal.
22	CLK	I	Serial data transfer clock input from microprocessor.	44	TDFCT	I	Capacitor connection terminal for time constant when defect.
				45	ATSC	I	Window comparator input terminal for ATSC detection.
				46	FZC	I	Focos zero-cross comparator input terminal.
				47	FE	I	Focus error input terminal.
				48	DFDCT	I	Capacitor connection terminal for time constant when defect.

SM5861AP (D/A converter)

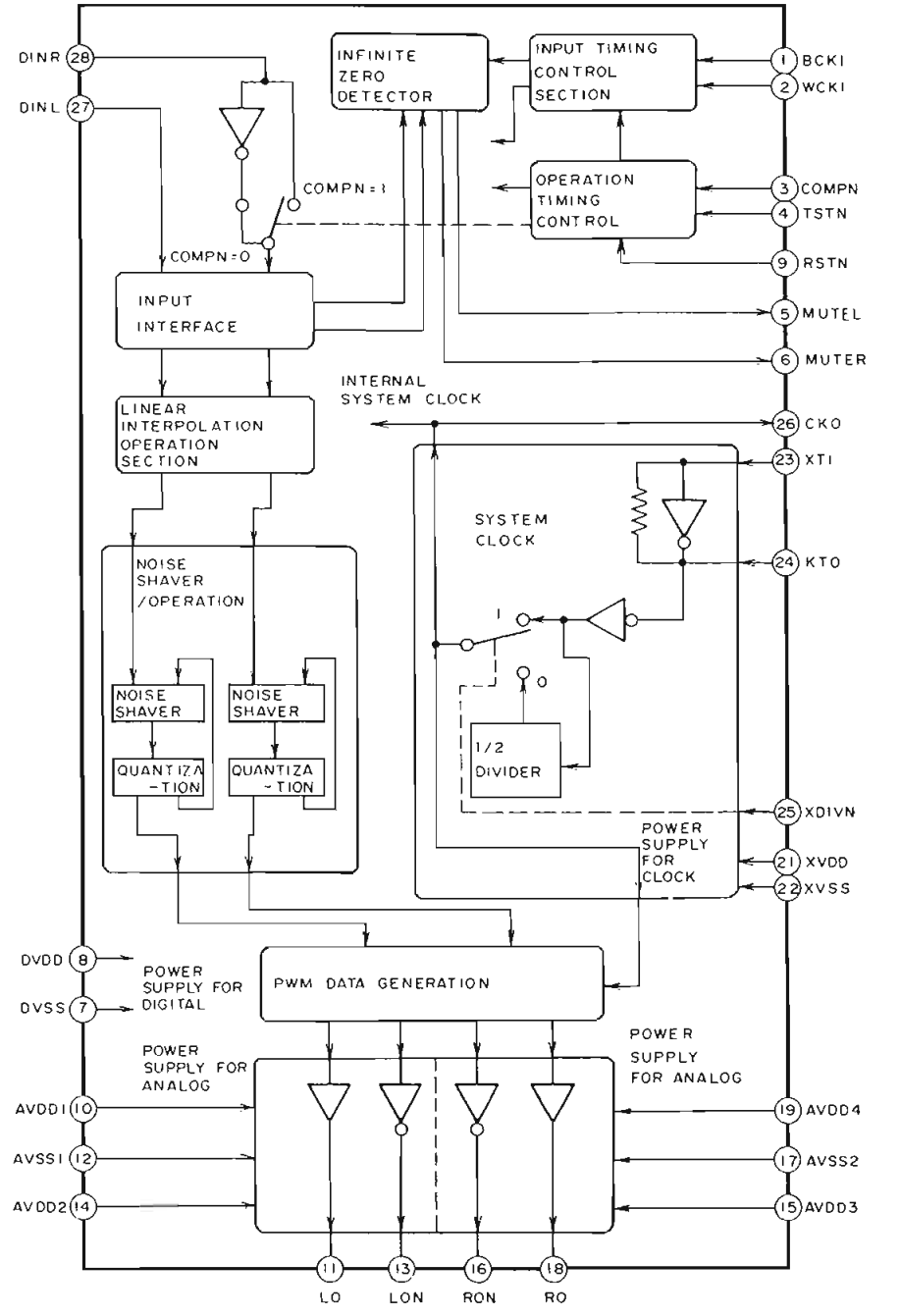

Pin No.	Symbol	Description	Pin No.	Symbol	Description
1	BCKI	Serial input data bit clock	15	AVDD3	5V supply for analogue section
2	WCKI	Input data word clock	16	RON	Data output
3	COMPN	Mode select of PWM output	17	AVSS2	Ground for analogue section
4	TSTN	Test terminal	18	RO	Data output
5	MUTEL	Muting output for left channel	19	AVDD4	Ground for analogue section
6	MUTER	Muting output for right channel	20	NC	
7	DVSS	Ground for digital section	21	XVDD	5V supply for clock section
8	DVDD	5V power supply for digital section	22	XVSS	Ground for clock section
9	RSTN	Reset input	23	XTI	Crystal oscillator input
10	AVDD1	5V supply for analogue section	24	XTO	Crystal oscillator output
11	LO	Data output	25	XDIVN	System clock select
12	AVSS1	Ground for analogue section	26	CKO	Clock output
13	LON	Data output	27	DINL	Serial data input for left channel
14	AVDD2	5V supply for analogue section	28	DINR	Serial data input for right channel

SM5843AP-ONK (8 Times Oversampling Digital Filter)

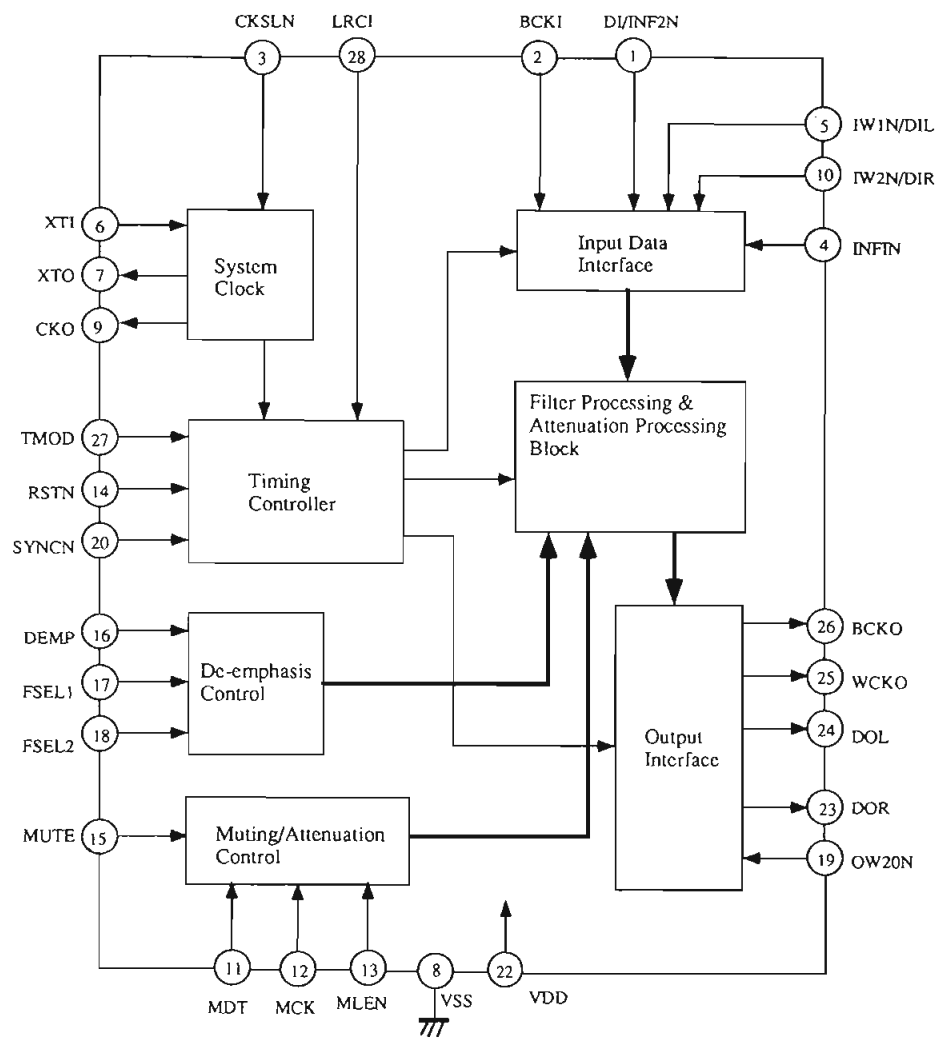

Data input	DI/INF2N	1	28	LRCI	Sample rate clock of input data
Bit clock input	BCKI	2	27	TMOD	Filter selector
Selector for resonator or input frequency	CKSLN	3	26	BCKO	Bit clock output
	INFIN	4	25	WCKO	Word clock output
	IWIN/DIL	5	24	DOL	L ch. data output
Clock input	XTI	6	23	DOR	R ch. data output
	XTO	7	22	VDD	
	VSS	8	21	NC	
Clock output	CKO	9	20	SYSCN	
	IW2N/DIR	10	19	OW2ON	
	MDT	11	18	FSEL2	
	MCK	12	17	FSEL1	
	MLEN	13	16	DEMP	DE-emphasis control ON:H
System reset	RSTN	14	15	MUTE	Muting output Mute: H

DISASSEMBLING PROCEDURES

1. Tray ass'y

- Remove the top cover.
- Remove the holder T and the retainer M.
- Turn the power switch to ON.
- Press the OPEN/CLOSE button to open the tray ass'y.
- Remove the chucking ass'y.
- Remove the stopper.
- Press the tray stopper to the arrow mark direction and remove the tray ass'y.

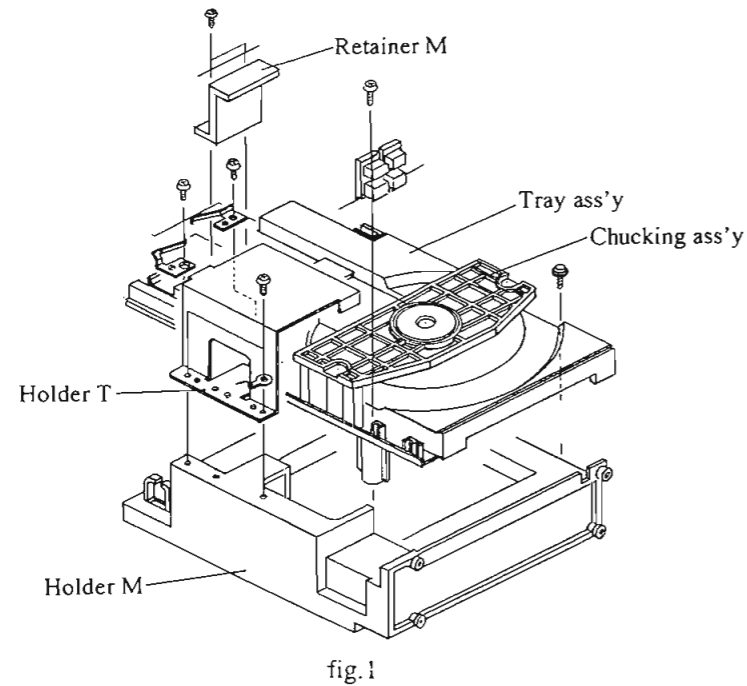

fig.1

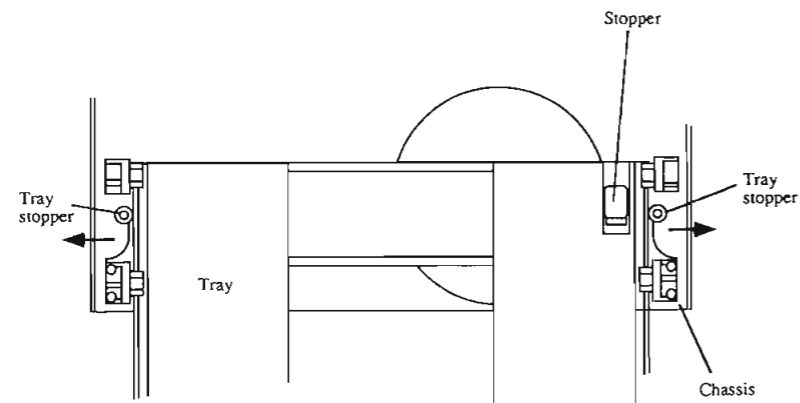
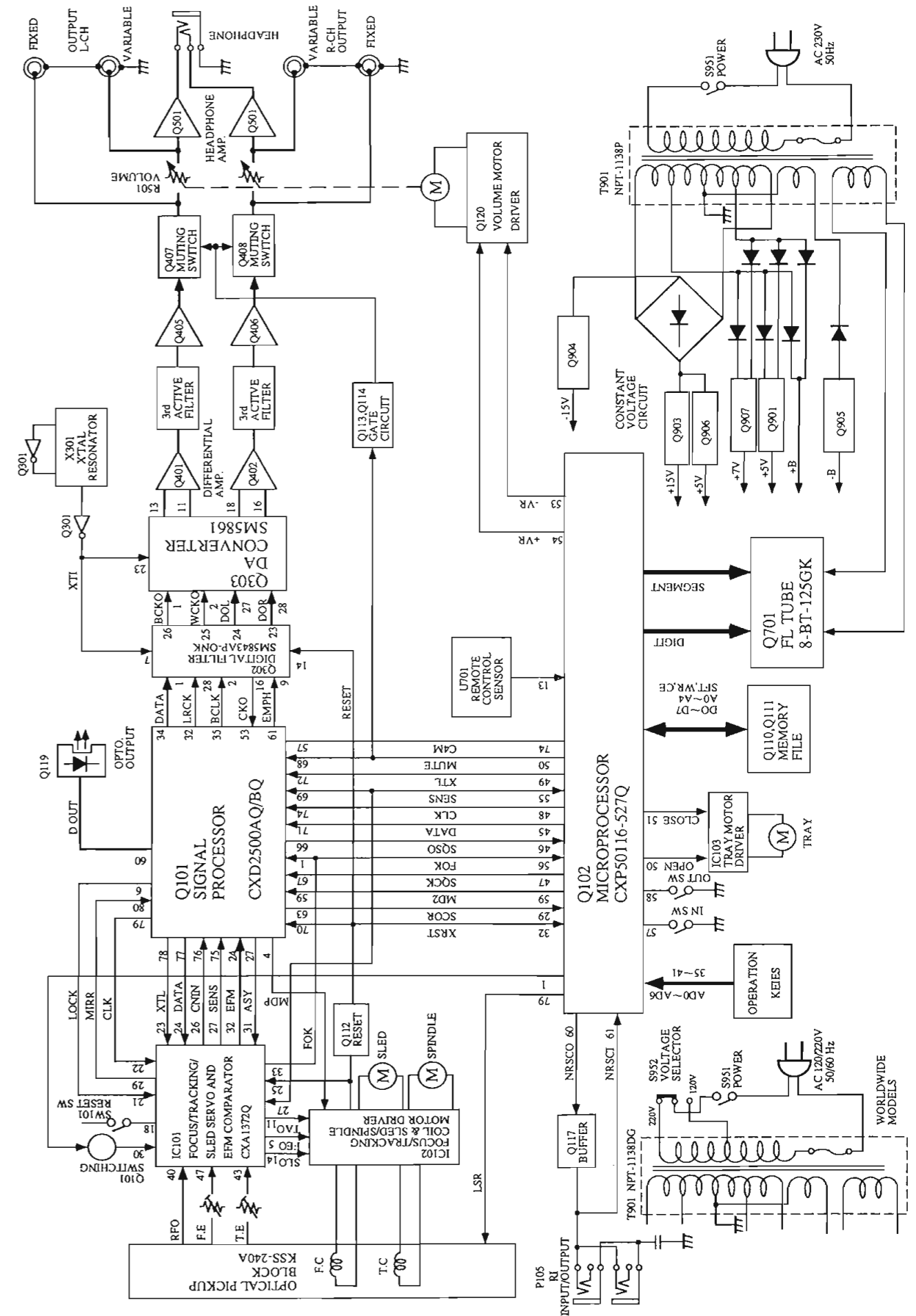

fig.2

2. CD mechanism ass'y

- Remove the tray ass'y.
- Remove the four screws holding the mechanism and the holder M.

BLOCK DIAGRAM



ADJUSTMENT PROCEDURES

It is not necessary to perform the adjustment of optical pickup. This confirmation should be made when replacing the optical pickup.

1). Connect the oscilloscope to test points RF and VC.

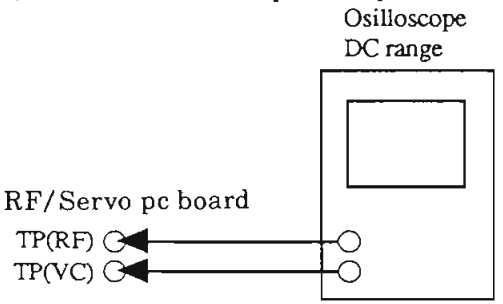

- 2). Turn the power switch on.
 - 3). Load the test disc YEDS-18 on the tray and press the play button.
 - 4). Confirm that the waveform on the oscilloscope is optimum eye pattern and optimum level as shown photo 1.
- Optimum eye pattern means that shape "◇" can be clearly distinguished at the center of the waveform.

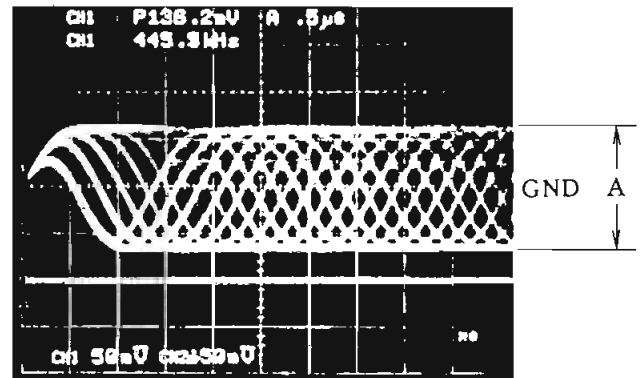

Photo 1
A = 1.2 ± 0.3Vp-p

REFERENCE

Focus/Tracking Gain Adjustment

A frequency response analyzer is necessary in order to perform this adjustment exactly.

However, this gain has a margin, so even if it is slightly off, there is no problem. Therefore, do not perform this adjustment.

Focus/tracking gain determines the pick-up follow-up (vertical and horizontal) relative to mechanical noise and mechanical shock when the 2-axis device operate.

However, as these reciprocate, the adjustment is at the point where both are satisfied.

- When gain is raised, the noise when the 2-axis device operates increases.
- When gain is lowered, it is more susceptible to mechanical shock and skipping occurs more easily.
- When gain adjustment is off, the symptoms below appear.

Symptoms	Gain	Focus	Tracking
• The time until music starts becomes longer for STOP → ▷PLAY or automatic selection (◀▶ buttons pressed). (Normally takes about 2 seconds.)		low	low or high
• Music does not start and disc continues to rotate for STOP → ▷PLAY or automatic selection (◀▶ buttons pressed.)		-	low
• Sound is interrupted during PLAY. Or time counter display stops progressing.		-	low
• More poise during 2-axis device operation.		high	high

The following is a simple adjustment method.

- Simple Adjustment -

Note: Since exact adjustment cannot be performed, remember the positions of the controls before performing the adjustment. If the positions after the simple adjustment are only a little different, return the controls to the original position.

Procedure:

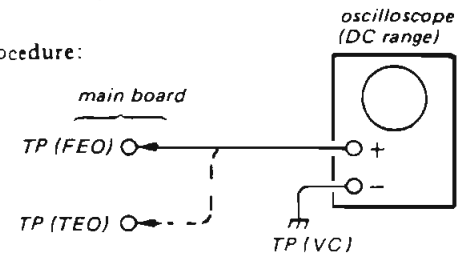

1. Keep the set horizontal.
(If the set is not horizontal, this adjustment cannot be performed due to the gravity against the 2 axis device.)
2. Insert disc (YEDS-18) and press ▷PLAY button.
3. Connect oscilloscope to RF/ Servo board TP (FE).
4. Adjust RV102 so that the waveform is as shown in the figure below. (focus gain adjustment)



• Incorrect Examples (DC level changes more than on adjusted waveform)

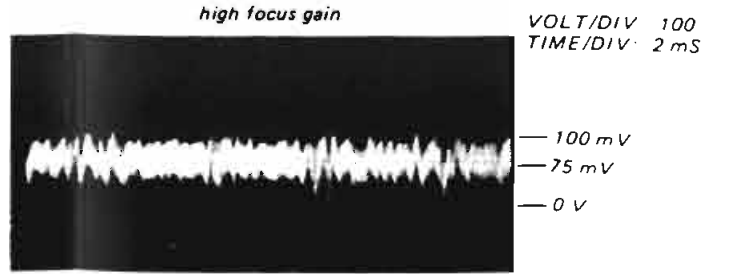
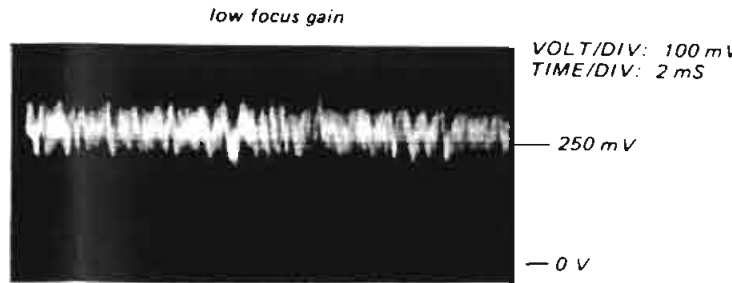

5. Connect oscilloscope to RF/ Servo board TP (TE).

6. Adjust RV101 so that the waveform is as shown in the figure below. (tracking gain adjustment)



• Incorrect Examples (fundamental wave appears)

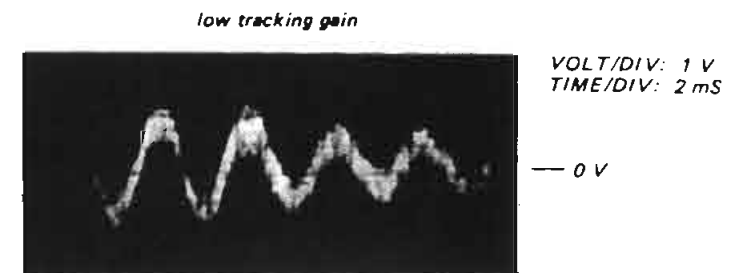

high tracking gain (higher fundamental wave than for low gain)

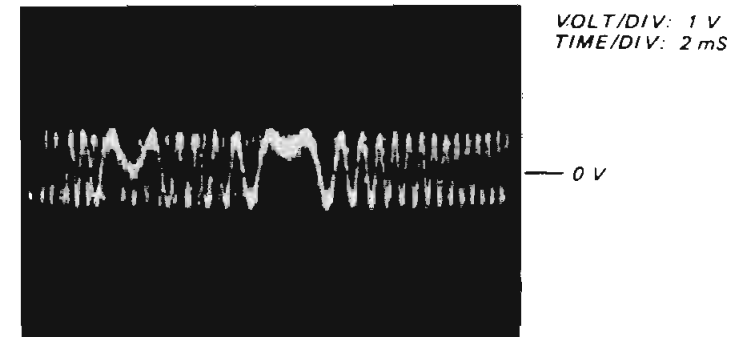

Adjustment Location: RF/ Servo board

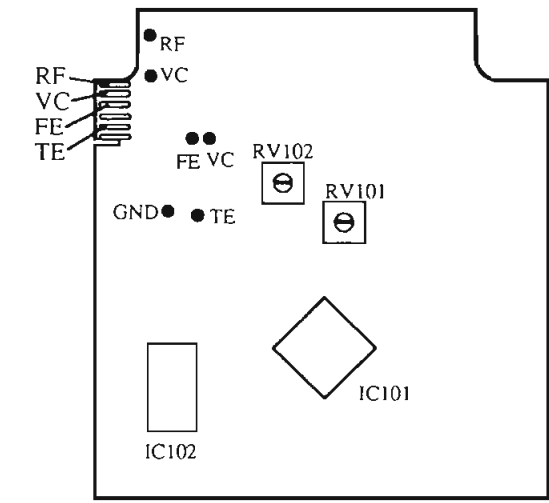

PRINTED CIRCUIT BOARD VIEW FROM BOTTOM SIDE

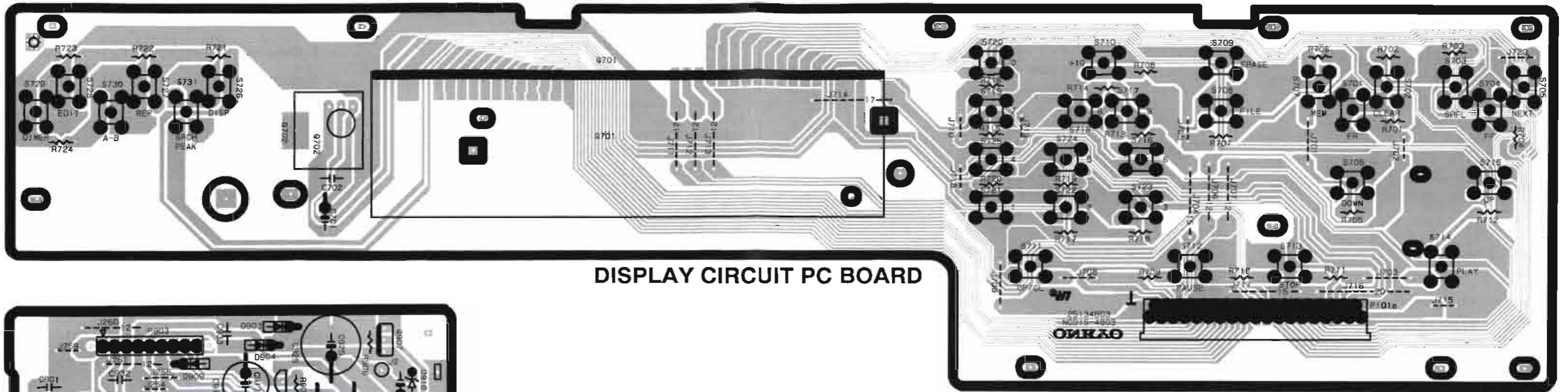

DISPLAY CIRCUIT PC BOARD

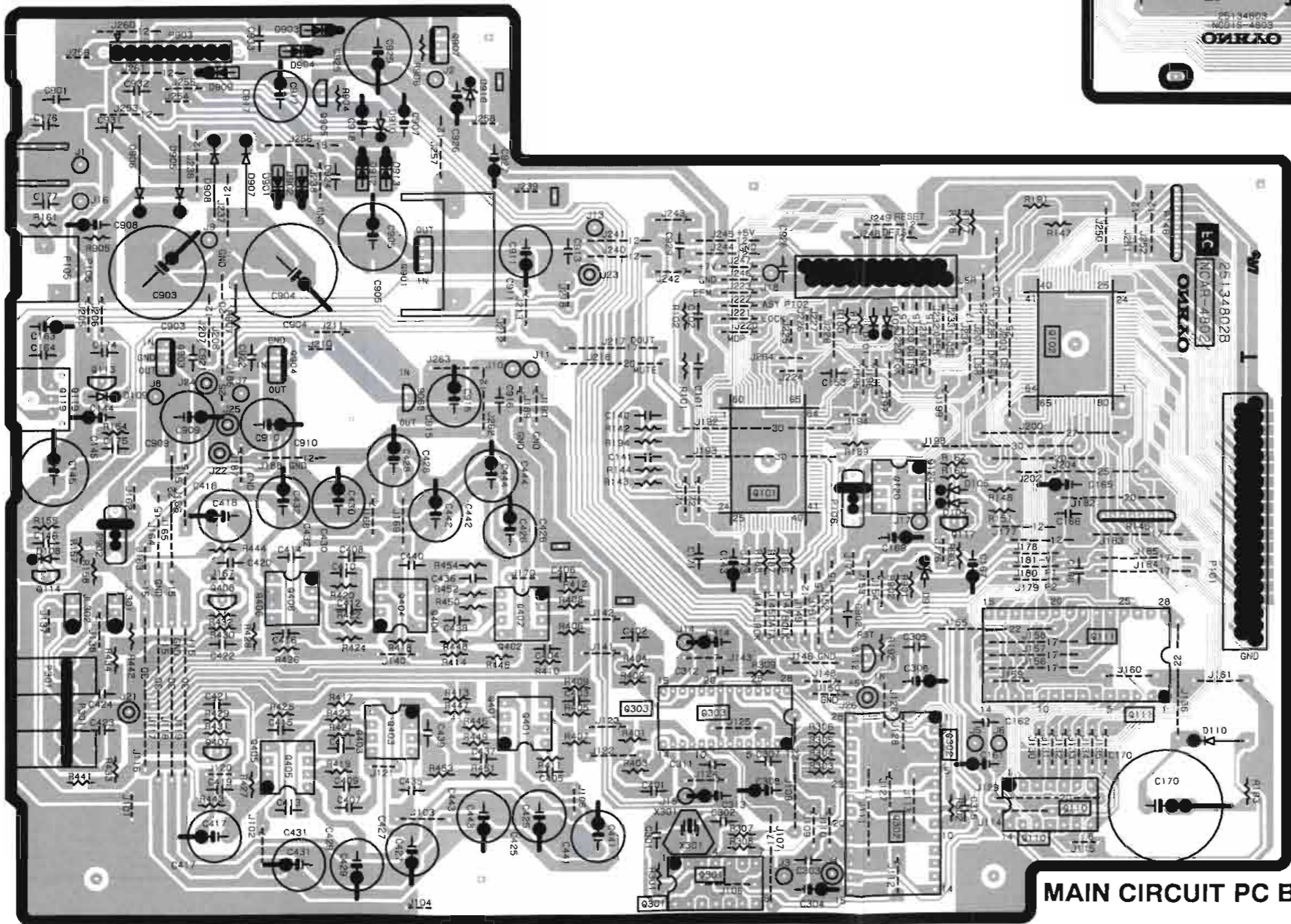

MAIN CIRCUIT PC BOARD

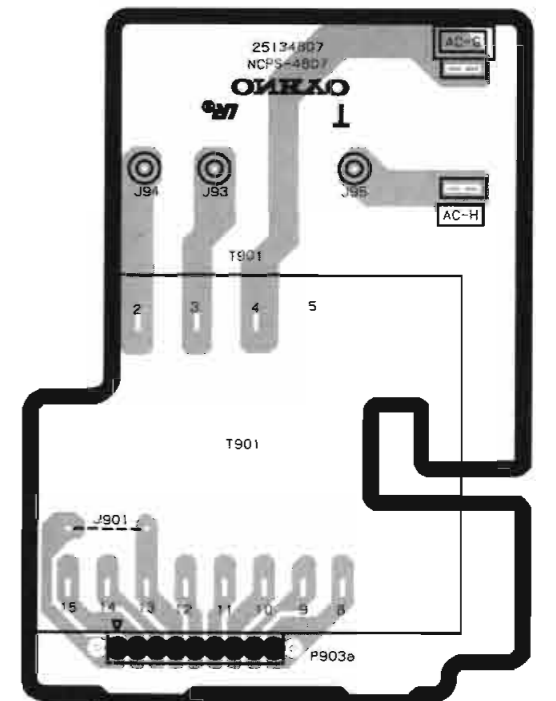

POWER TRANSFORMER PC BOARD

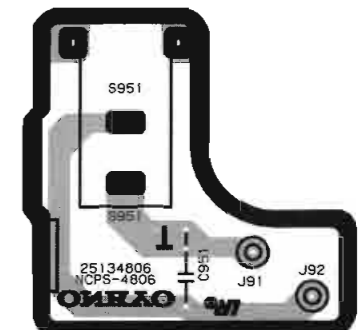

POWER SWITCH PC BOARD

SCHEMATIC DIAGRAM

1

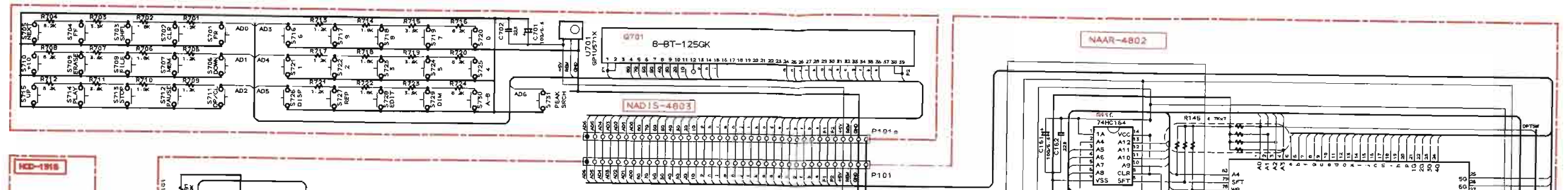

2

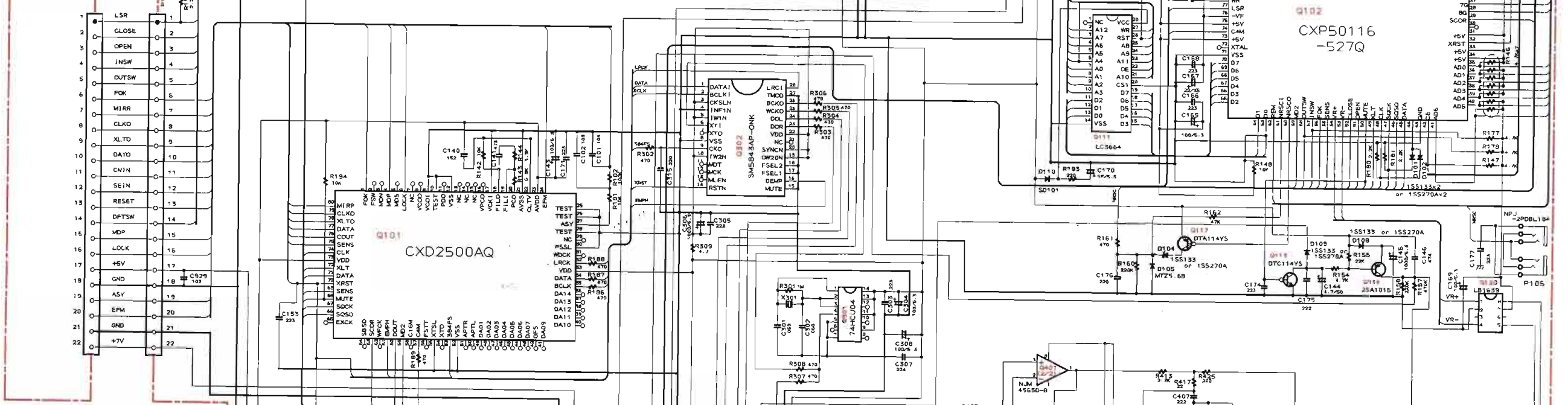

3

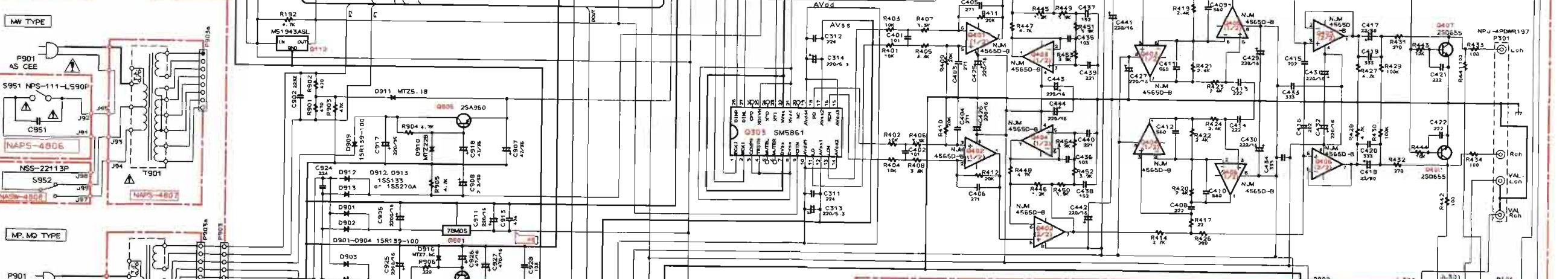

4

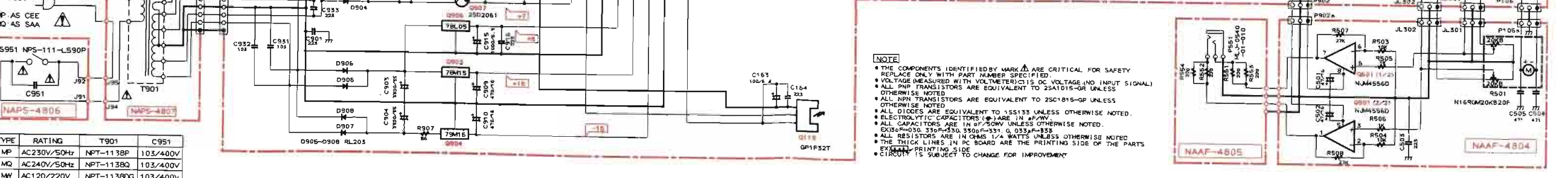

5

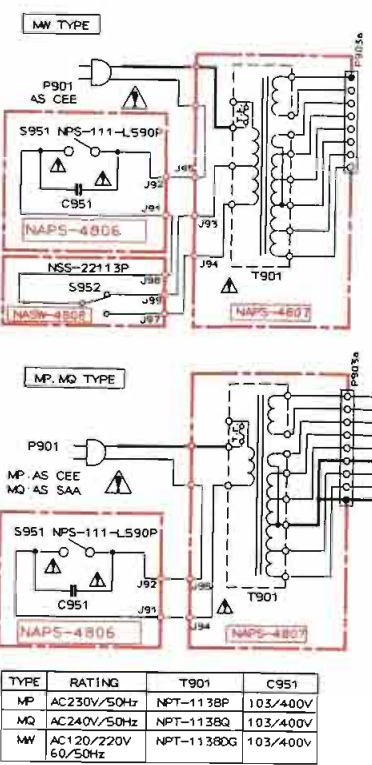

TYPE	RATING	T901	C951
MP	AC230V/50Hz	NPT-113BP	103/400V
MQ	AC240V/50Hz	NPT-113BQ	103/400V
MW	AC120/220V 60/50Hz	NPT-113BG	103/400V

NOTE

- THE COMPONENTS IDENTIFIED BY MARK Δ ARE CRITICAL FOR SAFETY. REPLACE ONLY WITH PART NUMBER SPECIFIED.
- VOLTAGE MEASURED WITH VOLTMETER IS DC VOLTAGE (NO INPUT SIGNAL) UNLESS OTHERWISE NOTED.
- ALL PNP TRANSISTORS ARE EQUIVALENT TO 2SA1015-OR UNLESS OTHERWISE NOTED.
- ALL NPN TRANSISTORS ARE EQUIVALENT TO 2SC1815-QP UNLESS OTHERWISE NOTED.
- ALL DIODES ARE EQUIVALENT TO 1SS133 UNLESS OTHERWISE NOTED.
- ELECTROLYTIC CAPACITORS (C) ARE IN μ F/WV.
- ALL CAPACITORS ARE IN P/F/50WV UNLESS OTHERWISE NOTED.
- EXCEPT FOR 33P/250V, 330P/250V, 0.033/50V, 0.033/100V.
- ALL RESISTORS ARE IN OHMS 1/4 WATTS UNLESS OTHERWISE NOTED.
- THE THICK LINES IN PCB ARE THE PRINTING SIDE OF THE PARTS EXCEPT PRINTING SIDE.
- CIRCUIT IS SUBJECT TO CHANGE FOR IMPROVEMENT.

PRINTED CIRCUIT BOARD – PARTS LIST

MAIN CIRCUIT PC BOARD(NAAR-4802-1A)

CIRCUIT NO.	PART NO.	DESCRIPTION	CIRCUIT NO.	PART NO.	DESCRIPTION
	ICs			Capacitors	
Q101	22240487 or 22240487A	CXD2500AQ or CXD2500BQ	C146	374724744	0.47 μ F \pm 5%, 50V, Plastic
Q102	22240725	CXP50116-527Q	C161, C163	354721019	100 μ F, 6.3V, Elect.
Q110	222741645	74HC164	C165, C169	354721019	100 μ F, 6.3V, Elect.
Q111	22240198, 22240754 or 22240755	LC3664NL-12, LC3664AL-12 or LC3664RL-12,	C167	354762209	22 μ F, 35V, Elect.
Q112	22240018	M51943ASL	C170	3000073 or 3000058	1F, 5.5V, Super
Q120	22240322	LB1639	C175	374722224	2200pF \pm 5%, 50V, Plastic
Q301	222755	74HC04P	C304, C308	354721019	100 μ F, 6.3V, Elect.
Q302	22240680A	SM5843AP-ONK	C307	374722244	0.22 μ F \pm 5%, 50V, Plastic
Q303	22240520	SM5861AP	C311, C312	374722244	0.22 μ F \pm 5%, 50V, Plastic
Q401-Q406	22240201	NJM4565D-B	C313, C314	354722219	220 μ F, 6.3V, Elect.
Q901	222780055MIT	M5F78M05L	C401, C402	373301014	100pF \pm 5%, 125V, Plastic
Q903	222780155MIT	M5F78M15L	C403-C406	373302714	270pF \pm 5%, 125V, Plastic
Q904	222790155MIT	M5F79M15L	C407, C408	374722224	2200pF \pm 5%, 50V, Plastic
Q906	222780053	78L05	C413, C414	374722224	2200pF \pm 5%, 50V, Plastic
	Transistors		C415, C416	374722024	2000pF \pm 5%, 50V, Plastic
Q113	221281	DTC114YS	C417, C418	354780229	22 μ F, 50V, Elect.
Q114	2211455	2SA1015-GR	C419, C420	374723334	0.033 μ F \pm 5%, 50V, Plastic
Q117	2213090	DTA114YS	C421, C422	374722224	2200pF \pm 5%, 50V, Plastic
Q407, Q408	2211706	2SD655-F	C425-C427	354742219	220 μ F, 16V, Elect.
Q905	2211503 or 2211504	2SA950-O or 2SA950-Y	C429-C432	354742219	220 μ F, 16V, Elect.
Q907	2202115 or 2202116	2SD2061-E or 2SD2061-F	C435, C436	374721034	0.01 μ F \pm 5%, 50V, Plastic
	Opto.module		C437, C438	374721524	1500pF \pm 5%, 50V, Plastic
Q119	24120038	GP1F32T	C439, C440	373302214	220pF \pm 5%, 125V, PP
	Diodes		C441-C444	354742219	220 μ F, 16V, Elect.
D101-D104	223163 or	1SS133 or	C903, C904	393163327	3300 μ F, 35V, Elect.
D108, D109	223205	1SS270A	C905, C925	354742229	2200 μ F, 16V, Elect.
D105	224450562	MTZ5.6B	C907	354764709	47 μ F, 35V, Elect.
D110	223191	SD101	C908	354780229	2.2 μ F, 50V, Elect.
D901-D904	22380032	1SR139-100	C909, C910	354744719	470 μ F, 16V, Elect.
D905-D908	22380045	RL203	C911	354742219	220 μ F, 16V, Elect.
D909	22380032	1SR139-100	C913	375524744	0.47 μ F \pm 5%, 50V, Plastic
D910	224452202	MTZ22B	C915	354721029	1000 μ F, 6.3V, Elect.
D911	224450512	MTZ5.1B	C917	354762219	220 μ F, 35V, Elect.
D912, D913	22380032	1SR139-100	C918	354764709	47 μ F, 35V, Elect.
D916	224450753	MTZ7.5C	C925	354742229	2200 μ F, 16V, Elect.
	X'tal		C926	354744709	47 μ F, 16V, Elect.
X301	3010159	AT-38-169	C927	354744719	470 μ F, 16V, Elect.
	Capacitors		C928, C929	374721034	0.01 μ F \pm 5%, 50V, Plastic
C101, C102	374721034	0.01 μ F \pm 5%, 50V, Plastic	C931, C932	374721034	0.01 μ F \pm 5%, 50V, Plastic
C140	374721524	1500pF \pm 5%, 50V, Plastic	C933	374722234	0.022 μ F \pm 5%, 50V, Plastic
C141	374724734	0.047 μ F \pm 5%, 50V, Plastic		Resistors	
C143	354721019	100 μ F, 6.3V, Elect.	R145, R146	49163472407	4.7k \times 7, 1/10W, Array
C144	354780479	4.7 μ F, 50V, Elect.	R907	441625604	56 Ω , .1W, Metal
C145, C306	354721029	1000 μ F, 6.3V, Elect.		Sockets	

CIRCUIT NO.	PART NO.	DESCRIPTION
P301	25045351	NPJ-4PDWR197, Output
	Terminal Holder	
	27190751	

DISPLAY CIRCUIT PC BOARD(NADIS-4803-1)

CIRCUIT NO.	PART NO.	DESCRIPTION
Q701	212109	8-BT-125GK, FL tube
Q702	24130007	GP1U571X, Remote control sensor
S701-S731	25035548	NPS-111-S510, Push switches
C701	353721019	100 μ F, 6.3V, Elect. capacitor
	27190754A	Holder FL
P101A	25050943	NSCT-37P730, Socket

HEADPHONE AMPLIFIER PC BOARD(NAAF-4804-1)

CIRCUIT NO.	PART NO.	DESCRIPTION
Q501	222654	NJM4556D, IC
C501, C502	354744709	47 μ F, 16V, Elect. capacitors
R501	5104327	N16RGM20KB20F, Variable resistor

HEADPHONE TERMINAL PC BOARD(NAAF-4805-1)

CIRCUIT NO.	PART NO.	DESCRIPTION
P551	25045139	HLJ-0540-01-010, Headphone jack

POWER SWITCH PC BOARD(NAPS-4806-1/1A)

CIRCUIT NO.	PART NO.	DESCRIPTION
C951	3500065A	Δ DE7150FZ103PAC400V/ 125V, IS capacitor
S951	25035636	Δ NPS-111-S590P, Power switch

VOLTAGE SELECTOR SWITCH PC BOARD(NASW-4808-1)

CIRCUIT NO.	PART NO.	DESCRIPTION
S952	25065287	Δ NSS-22113P, Slide switch

NOTE: THE COMPONENTS IDENTIFIED BY MARK Δ ARE CRITICAL FOR RISK OF FIRE AND ELECTRIC SHOCK. REPLACE ONLY WITH PART NUMBER SPECIFIED.

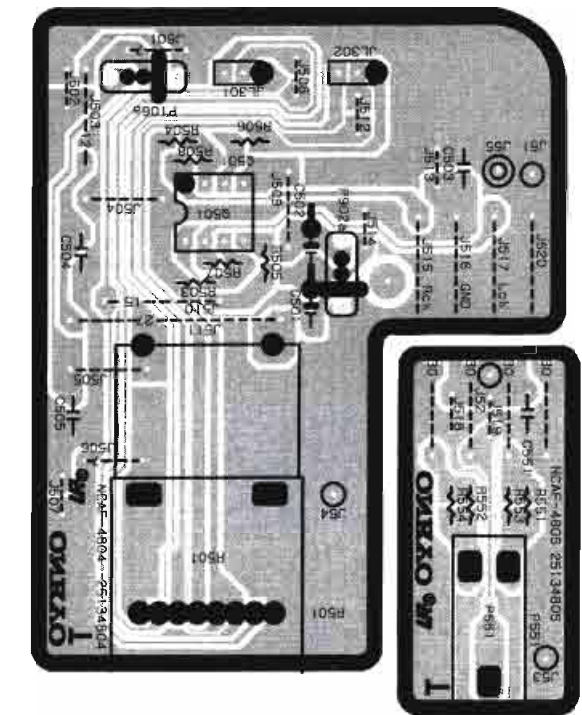

HEADPHONE PC BOARDS

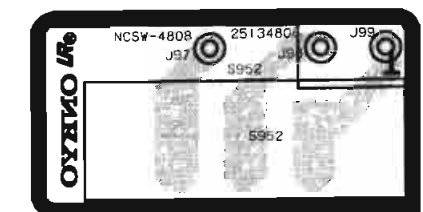

VOLTAGE SELECTOR SWITCH PC BOARD

MECHANISM PC BOARD

CIRCUIT NO.	PART NO.	DESCRIPTION
IC101	24840089	CXA1372AQ, IC
IC102	22240551	LA6532M-T1, IC
IC103	22240101	M54641L, IC
RV101, 102	24840085	10K, Trim resistor
SW101	24840070	Leafswitch
CN101	24840072	Connector pin
CN102	24840071	Connector socket

SCHEMATIC DIAGRAM MECHANISM BLOCK

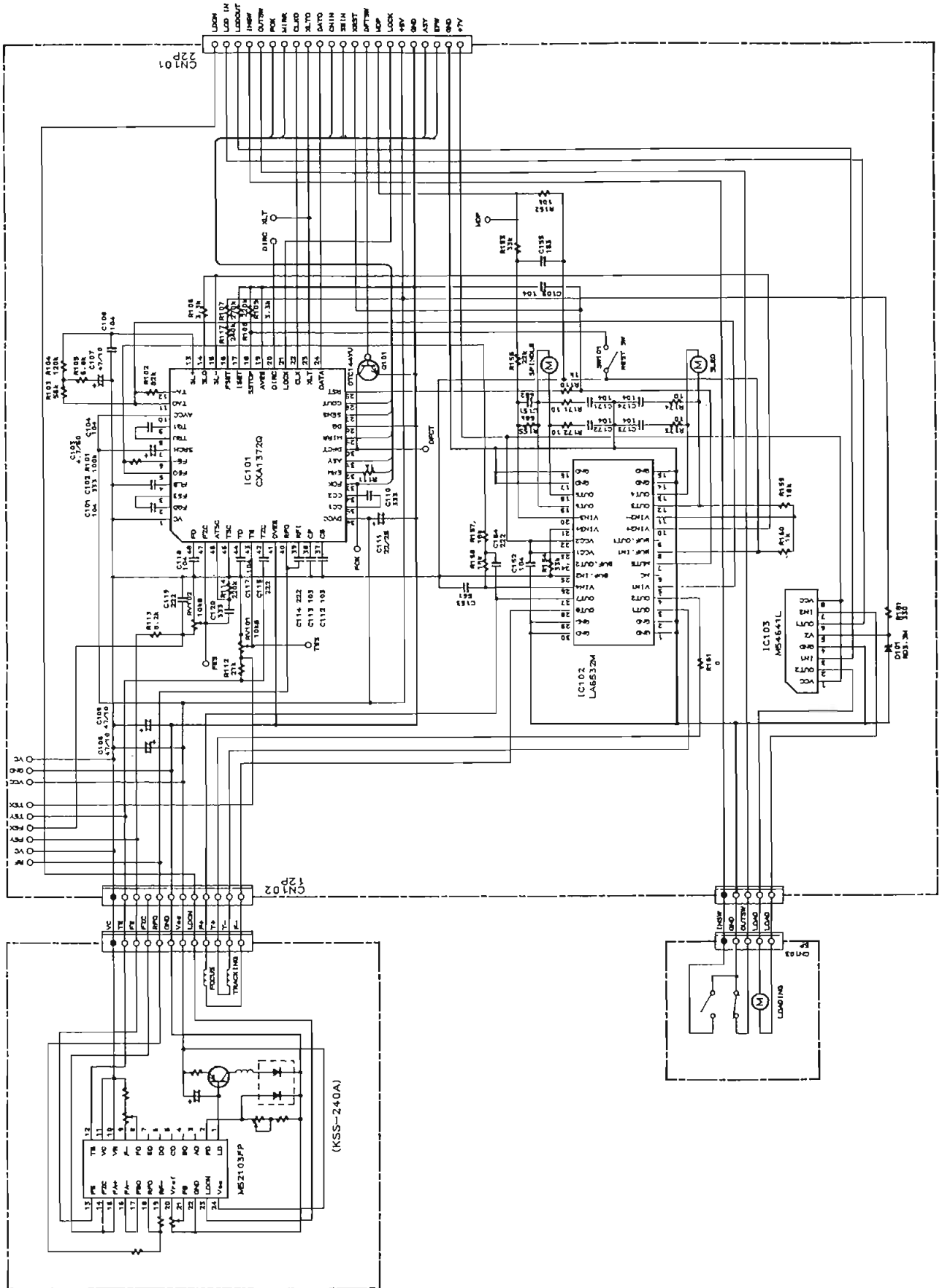

PACKING VIEW

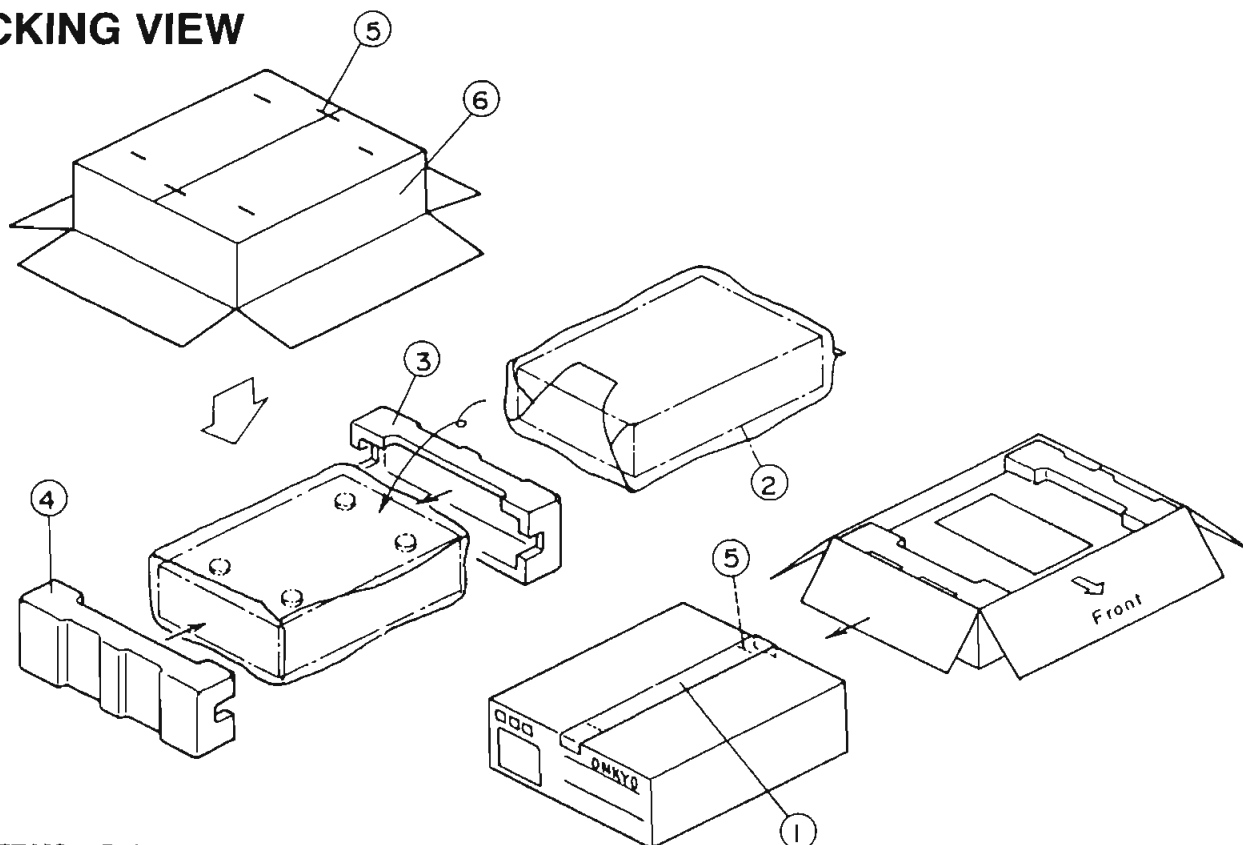

REF.NO.	PART NO.	DESCRIPTION
1	29110071	50×60cm,PP tape
2	29100037	650×500mm,Styrene bag
3	29091637-1Y	Pad R
4	29091636-1Y	Pad L
5	282301	Staple
6	29052641Y	Master carton box
Accessory bag ass'y		
	2010098A	Connection cable
	2010200	Connection cable for remote control
	24140221Y	RC-221C,Remote control transmitter
	3010054	UM-3,Two batteries
	29341851Y	Instruction manual <P>
	29341863Y	Instruction manual <W>
	29100097-1	350×250mm,Styrene bag
	25055040	CV-K-2,Conversion plug <W>

NOTE:<P>:230V model only

<W>:Worldwide model only

ONKYO CORPORATIONSales Planning & Promotion Dept.: 2-1, Nisshin-cho, Neyagawa-shi, OSAKA 572, JAPAN
Tel: 0720-31-8133 Fax: 0720-34-1340**ONKYO U.S.A CORPORATION**200 Williams Drive, Ramsey, N.J. 07446, U.S.A.
Tel: 201-825-7950 Fax: 201-825-8150**ONKYO DEUTSCHLAND GMBH ELECTRONICS**Industriestrasse 18-20, D-82110 Germering, GERMANY
Tel: 089 84 93 20 Fax: 089 84 93 226 TLX: 05-21726 ONKY D**ONKYO FRANCE**Immeuble Le Diamant, Domaine Technologique de Saclay, 4 Rue René Razel,
91892 SACLAY, FRANCE Tel: (1) 69 33 14 00 Fax: (1) 69 41 35 84