

ONKYO® SERVICE MANUAL

COMPACT DISC PLAYER MODEL DX-7911

Black model/Silver model/Golden model

UD	120V AC, 60Hz
UP	230V AC, 50Hz
UW	120/220V AC, 50/60Hz

SAFETY-RELATED COMPONENT WARNING!!

COMPONENTS IDENTIFIED BY MARK \triangle ON THE SCHEMATIC DIAGRAM AND IN THE PARTS LIST ARE CRITICAL FOR RISK OF FIRE AND ELECTRIC SHOCK. REPLACE THESE COMPONENTS WITH ONKYO PARTS WHOSE PARTS NUMBERS APPEAR AS SHOWN IN THIS MANUAL.

MAKE LEAKAGE-CURRENT OR RESISTANCE MEASUREMENTS TO DETERMINE THAT EXPOSED PARTS ARE ACCEPTABLY INSULATED FROM THE SUPPLY CIRCUIT BEFORE RETURNING THE APPLIANCE TO THE CUSTOMER.



SPECIFICATION

Compact Disc Player	Model DX-7911
Signal readout system:	Optical non-contact
Reading rotation:	About 500 - 200 r.p.m. (constant linear velocity)
Linear velocity:	1.2 - 1.4 m/s
Error correction system:	Cross Interleave Reed-Solomon code
D/A converter:	1 bit PWM ACCUPULSE D/A CONVERTER
Sampling frequency:	352.8 kHz (Eight-times oversampling)
Number of channels:	2 (stereo)
Frequency response:	2 Hz - 20 kHz
Total harmonic distortion: (at 1 kHz)	0.0025 %
Dynamic range:	110 dB
Signal to noise ratio:	110 dB
Channel separation: (at 1 kHz)	108 dB
Wow and Flutter:	Below threshold of measurability
Output level:	2 volts r.m.s.
Headphone jack:	1 Optimum load impedance 8 to 200 ohms
Power consumption:	26 watts
Power supply rating:	European and Australian models: AC 230 V, 50 Hz USA and Canadian models: AC 120 V, 60 Hz Worldwide model: AC 120 V and AC 220-230V switchable, 50/60 Hz
Dimensions (W × H × D):	435 × 131 × 365 mm (17-1/8" × 5-3/16" × 14-3/8")
Weight:	10.5 kg, 23.1 lbs.

Specifications and external appearance are subject to change without notice because of product improvements.

TABLE OF CONTENTS

Specification	1
Service procedures	2
Laser warning label	3
Chassis exploded view	4
Chassis exploded view parts list	5
Mechanism exploded view	6
Mechanism exploded view parts list	7
Microprocessor connection diagram	8
Microprocessor terminal description	9
IC block diagram and description	10-15
Caution on replacement of pickup	16
Adjustment procedure	17
Block diagram	18
Parts list	19-20
Printed circuit board view from bottom side	21-24
Schematic diagram	25-26
Packing view	27

SERVICE PROCEDURES

1. How to Release the Transport Lock

To protect the optical assembly including the laser pickup from vibration related damage during shipping, this unit is equipped with a transport lock lever located on the base.

1. Loosen the screw with Phillips screwdriver.
2. Move the lock lever in the direction opposite that shown by the arrow. Move the lever up to the position where it can move no farther, and then remove the lever.

■ Tighten the screw to secure the lock lever.

- For shipping, restore the lock lever to its position in the direction of the arrow, then tighten down the screw to secure the lock lever in that position.

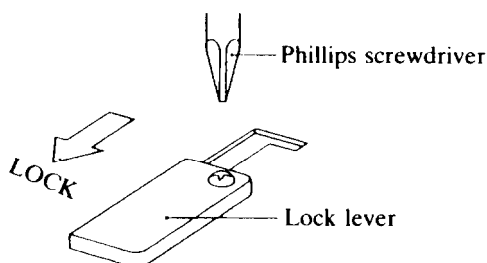

2. Use of batteries

- The remote control transmitter is powered by two batteries. Before using this unit for the first time, insert the two batteries (included).
- Average battery life is about one year. This period may be shorter depending on the frequency of use and environment (temperature and humidity) in which the remote control transmitter is used.

- If the remote control transmitter does not operate even though front panel controls function normally, the batteries should be replaced. Use only listed in the following chart.

Type	Voltage	Size
Manganese	1.5V	AA R6 UM-3

3. Safety check out

After correcting the original service problem, perform the following safety check before releasing the set to the customer:

Connect the insulating-resistance tester between the plug of power supply cable and chassis.

Specifications: more than 10Mohm at 500V.

4. Voltage selector (rear panel)

Worldwide models are equipped with a voltage selector to conform with local power supplies. Be sure to set this selector to match the voltage of the power supply in your area before turning the power switch on. Voltage is changed by turning the voltage selector with a screwdriver or similar instrument to the 120V or 220V position. Confirm that the selector has been set to the correct position before turning the power switch on. If there is no voltage selector switch on the unit you have purchased, it can only be used in areas where the power supply voltage is the same as that of the unit.

PROTECTION OF EYES FROM LASER BEAM DURING SERVICING

This set employs a laser. Therefore, be sure to follow carefully the instructions below when servicing.

WARNING!!

WHEN SERVICING, DO NOT APPROACH THE LASER EXIT WITH THE EYE TOO CLOSELY. IN CASE IT IS NECESSARY TO CONFIRM LASER BEAM EMISSION, BE SURE TO OBSERVE FROM A DISTANCE OF MORE THAN 30cm FROM THE SURFACE OF THE OBJECTIVE LENS ON THE OPTICAL PICK-UP BLOCK.

LASER WARNING LABELS

The label shown below are affixed.

1. Warning lable

These labels are located on the rear panel and the arm of the mechanism.

- (A) **DANGER** —INVISIBLE LASER RADIATION WHEN OPEN AND INTERLOCK FAILED OR DEFEATED. AVOID DIRECT EXPOSURE TO BEAM
- CAUTION** —HAZARDOUS LASER AND ELECTROMAGNETIC RADIATION WHEN OPEN AND INTERLOCK DEFEATED
- ATTENTION** —RAYONNEMENT LASER ET ELECTROMAGNETIQUE DANGEREUX SI OUVERT AVEC L'ECLANCHEMENT DE SECURITE ANNULE.

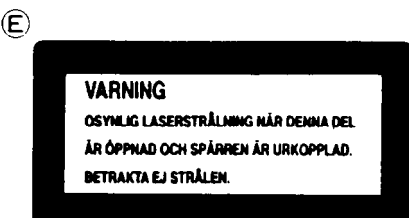
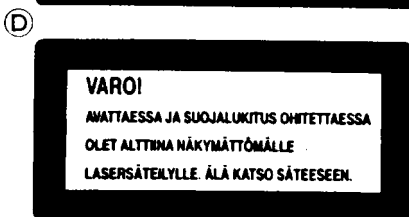
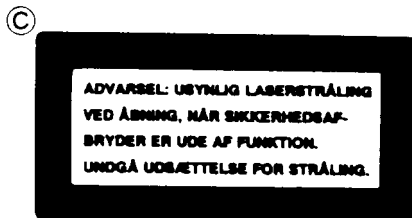
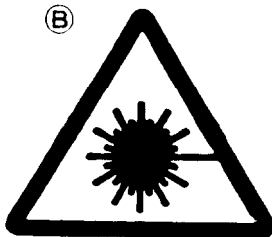

- (A) : Danger label
 (B) : Except 120V model
 (C) : Except 120V model
 (D),(E),(F) : Only 230V model

Laser Diode Properties

- Material: GaAS/GaAlAs
- Wavelength: 780nm
- Emission Duration: continuous
- Laser output: max. 0.5mW*

*This output is the value measured at a distance about 1.8mm from the objective lens surface on the Optical Pick-up Block.

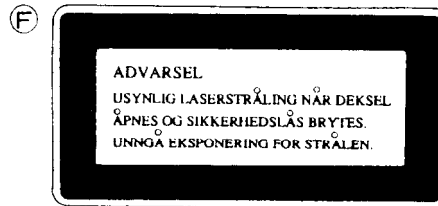

2. Certification label (120V model)

This label is located on the back panel.

PRODUCT IS CERTIFIED BY THE MANUFACTURER TO COMPLY WITH DHS RULES 21 CFR SUBCHAPTER J APPLICABLE AT THE DATE OF MANUFACTURE

MANUFACTURED

3. Class 1 label (Except 120V model)

This label is located on the back panel.

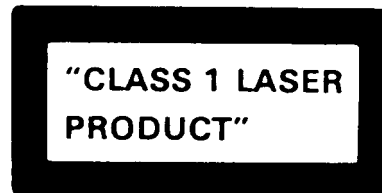

LUOKAN 1 LASERLAITE

KLASS 1 LASER APPARAT

ADVARSEL

Denna mærkning er anbragt på apparatets højre side og indikerer, at apparatet arbejder med laserstråler af klasse 1, hvilket betyder, at der anvendes laserstråler af svageste klasse, og at man ikke på apparatets yderside kan blive udsat for utilsigelig kraftig stråling.

APPARATET BØ/R KUN ÅBNES AF FAGFOLK MED SÆRLIGT KENDSKAB TIL APPARATER MED LASERSTRÅLER!

Indvendigt i apparatet er anbragt den her gengivne advarselsmærkning, som advarer imod at foretage sådanne indgreb i apparatet, at man kan komme til at udsætte sig for laserstråling.

VAROITUS! LAITTEEN KAYTTAMINEN MUULLA KUIN TASSA KAYTTOOHJEESSA MAINTULLA TAVALLA SAATTAÄ ALTISTAA KAYTTAJAN TURVALLISUUSLUOKAN 1 YLITTAVALLE NÄKYMÄTÖMÄLLE LASERSÄTEILYLLE.

CHASSIS EXPLODED VIEW PARTS LIST

REF NO.	PART NO.	DESCRIPTION	REF NO.	PART NO.	DESCRIPTION
A1	27110913	FRONT BRACKET AS <S>	A519	27175311	LEG AS
	27110912	FRONT BRACKET AS 	A520	831430088	3TTW+8B(BC), SCREW
	27110904	FRONT BRACKET AS <G>	A522	28184632	COVER (M)
A2	838130088	3TTB+8B, SCREW	A523	838430088	3TTB+8B(BC), SCREW
A3	28133345	BACK PLAET <S,G>	A525	28184634	COVER (PC)
	28133349-1	BACK PLAET 	A526	838430088	3TTB+8B(BC), SCREW
A4	28191731	CLEAR PLATE	A528	27190972	HOLDER (L)
A6	27100308	CHASSIS	A529	838230088	3TTB+8B(Ni), SCREW
A7	838430088	3TTB+8B(BC), SCREW	C901	△ 3300001	CK45F250V 103Z, CAPACITOR
A9	27130768	BRACKET (KZ)	L901	230915	CORE
A10	838130088	3TTB+8B, SCREW	L901A	831430088	3TTW+8B(BC), SCREW
A12	27130765A	BRACKET (D)	P901	△ 27300750	CORD BUSHING
A13	838430088	3TTB+8B(BC), SCREW	P951	△ 253148	AS-CEE, AC CORD <P,W>
A15	27130766A	BRACKET (U)		△ 253196HIT	AS-BS, AC CORD <E>
A16	838130088	3TTB+8B, SCREW		△ 253168	AS-UC-6#18, AC CORD <D>
A18	27130764	BRACKET (PC)	T901	△ 2301151	NPT-1257P, POWER TRANSFORMER <P>
A19	838430088	3TTB+8B(BC), SCREW		△ 2301150	NPT-1257P, POWER TRANSFORMER <D>
A21	27190934BY	HOLDER (CH)		△ 2301152	NPT-1257DG, POWER TRANSFORMER <W>
A22	838130088	3TTB+8B, SCREW	U1	1H298545-1C	NAAR-5645-1C <P>
A24	27141655	RETAINER (C)		1H298545-1B	NAAR-5645-1B <D>
A25	838130088	3TTB+8B, SCREW		1H298545-1D	NAAR-5645-1D <W>
A27	831430088	3TTW+8B(BC), SCREW	U2	1H298549-1C	NADIS-5649-1C <P>
A28	27122175	REAR PANEL <P>		1H298549-1B	NADIS-5649-1B <D>
	27122174	REAR PANEL <D>		1H298549-1D	NADIS-5649-1D <W>
	27122176	REAR PANEL <W>	U3	1H298546-1C	NAPS-5646-1C <P>
A29	838430088	3TTB+8B(BC), SCREW		1H298546-1B	NAPS-5646-1B <D>
A30	27273161	JOINT (POW)		1H298546-1D	NAPS-5646-1D <W>
A33	830440109	4TTC+10C(BC), SCREW	U4	1H298551-1C	NASW-5651-1C <P>
A34	838130088	3TTB+8B, SCREW		1H298551-1B	NASW-5651-1B <D>
A301	28184640	TOP COVER <S>		1H298551-1D	NASW-5651-1D <W>
	28184639	TOP COVER 	U5	1H298547-1C	NAAF-5647-1C
	28184641	TOP COVER <G>		1H298547-1B	NAAF-5647-1B
A302	838240089	4TTB+8C(Ni), SCREW <S,G>		1H298547-1D	NAAF-5647-1D
	838440088	4TTB+8C(BC), SCREW 	U6	1H298550-1C	NADG-5650-1C
A303	838430088	3TTB+8B(BC), SCREW		1H298550-1B	NADG-5650-1B
A501	27211780	FRONT PANEL <S>		1H298550-1D	NADG-5650-1D
	27211779	FRONT PANEL 	E801	2046304012	NCFC6-304012, FLAT CABLE
	27211781	FRONT PANEL <G>	E802	2047271512	NCFC7-271512, FLAT CABLE
A509	28141288	10.8×19×15, CUSHION	E803	2046182012	NCFC6-182012, FLAT CABLE
A510	29110023	DF TAPE	E804	2061112200UL	CRIMP AS
A511	838430088	3TTB+8B(BC), SCREW	Z1	1H287122UJ	MECHA AS
A513	28148335	DOOR <S>	Z2	838130088	3TTB+8B(BC), SCREW
	28148334	DOOR 	Z3	838430088	3TTB+8B(BC), SCREW
	28148333	DOOR <G>			
A514	834426068	2.6TTS+6B(BC), SCREW			<S> : Silver model only
A516	28325265	KNOB (POW) AS <S>			 : Black model only
	28325264	KNOB (POW) AS 			<G> : Golden model only
	28325238	KNOB (POW) AS <G>			<D> : 120V model only
A517	28325277	KNOB (LEV) <S>			<P> : 230V model only
	28325276	KNOB (LEV) 			<W> : Worldwide model only
	28325243	KNOB (LEV) <G>			<N> : American model only
					<C> : Canadian model only
					<E> : British model only
					<A> : Australian model only
					<T> : Taiwanese model only
					<GN> : American golden model only

NOTE: THE COMPONENTS IDENTIFIED BY MARK △ ARE CRITICAL FOR RISK OF FIRE AND ELECTRIC SHOCK. REPLACE ONLY WITH PART NUMBER SPECIFIED.

MECHANISM-EXPLODED VIEW

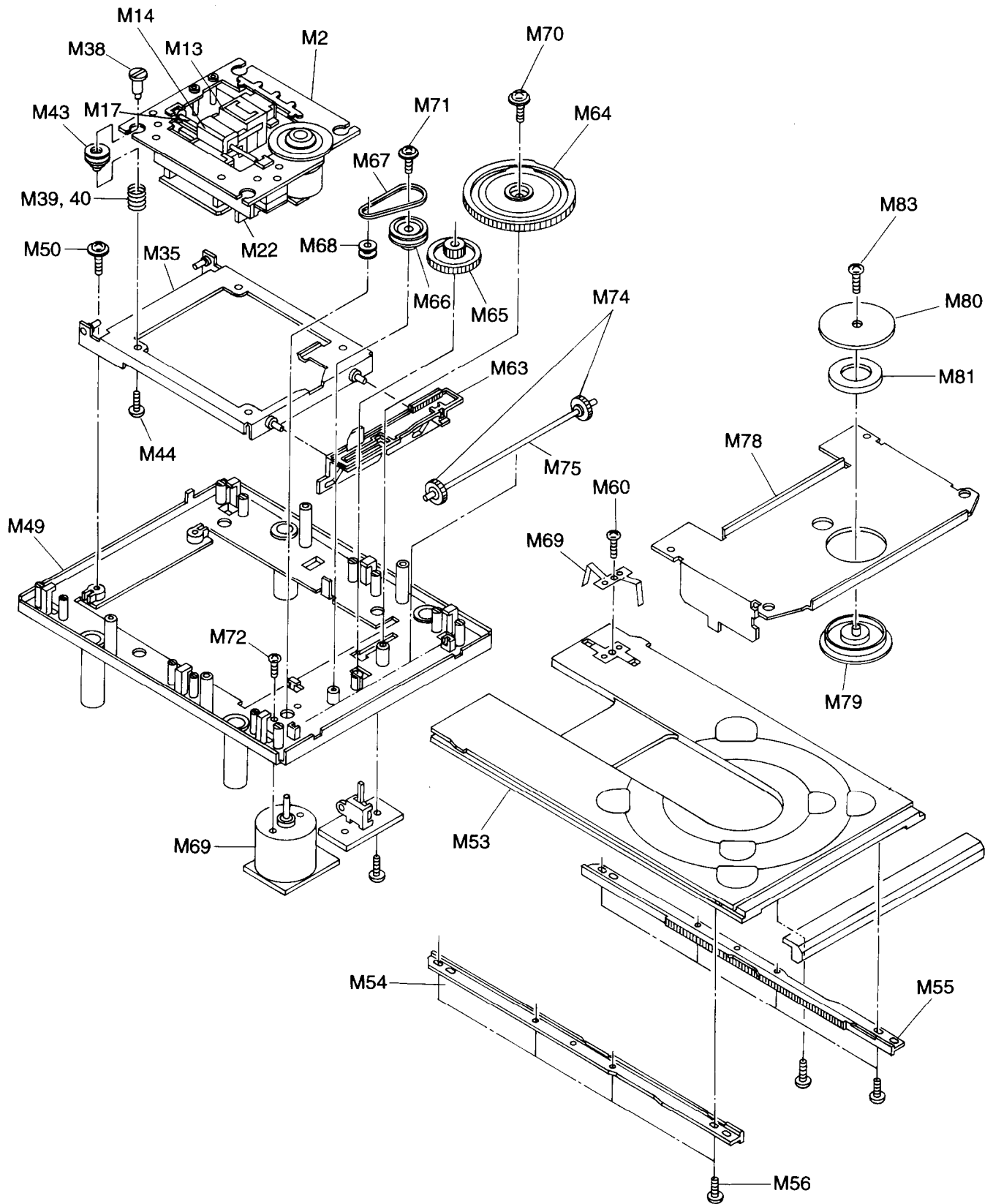

MECHANISM-PARTS LIST

REF NO.	PART NO.	DESCRIPTION
M2	24802023	CHASSIS (PU)AS
M13	24804019	PICK UP
M14	24840100	BLOCK (RET)
M17	24828013	SHAFT (PU)
M18	27270322	SPACER
M19	27270323	SPACER
M21	24804020	LINEAR MOTOR
M35	24802020	CHASSIS (SUB)AS
M38	24826007	HOLDER (FLT)
M39	27180462	SPRING (FRG)
M40	27180461	SPRING (FLS)
M43	27301466A	CUSHION
M44	82142004	2P+4F(BC), SCREW
M49	24802022	CHASSIS (MAIN)
M50	831430088	3TTW+8B(BC), SCREW
M53	24840104	DISC TRAY
M54	24810032	RACK (L)
M55	24810033	RACK (R)
M56	834426068	2.6TTS+6B(BC), SCREW
M59	24820031	PLATE (E)
M60	838430088	3TTB+8B(BC), SCREW
M63	24810034	CAM PLATE
M64	24810035	GEAR (MAIN)
M65	24810036	GEAR
M66	24810037	PULLEY
M67	24816012	BELT
M68	27300859A	PULLEY MO
M69	24502234	MDH2B60, MOTOR
M70	831430088	3TTW+8B(BC), SCREW
M71	831126060	2.6TTW+6P, SCREW
M72	82113003	3P+3F, SCREW
M74	24810038	GEAR (SYN)
M75	24828015	SHAFT (SYN)
M78	24840102	PLATE (CH)
M79	24824005	CAP (CH)
M80	27301344	YOKE (CH)
M81	28181019A	MAGNET
M83	833426050	2.6TTP+5P(BC), SCREW
M85	838430088	3TTB+8B(BC), SCREW
M86	2061112060UL	CRIMP AS
M92	1H287553-1	NAETC-5653-1
M93	2049041022	NCFC9-041022, FFC
M94	2042131022	NCFC2-131022, FFC
M95	834426068	2.6TTS+6B, (BC), SCREW

MICROPROCESSOR CONNECTION DIAGRAM

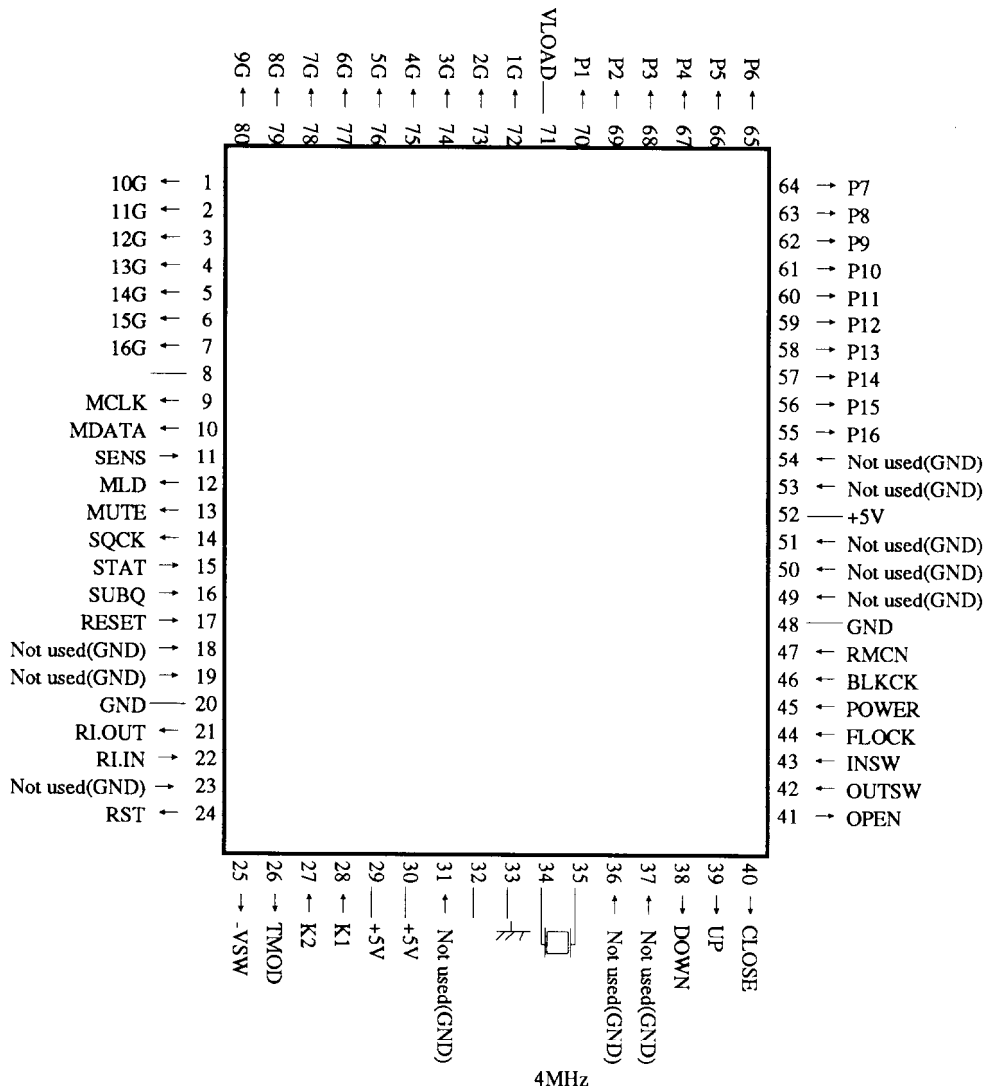

SM5843AP

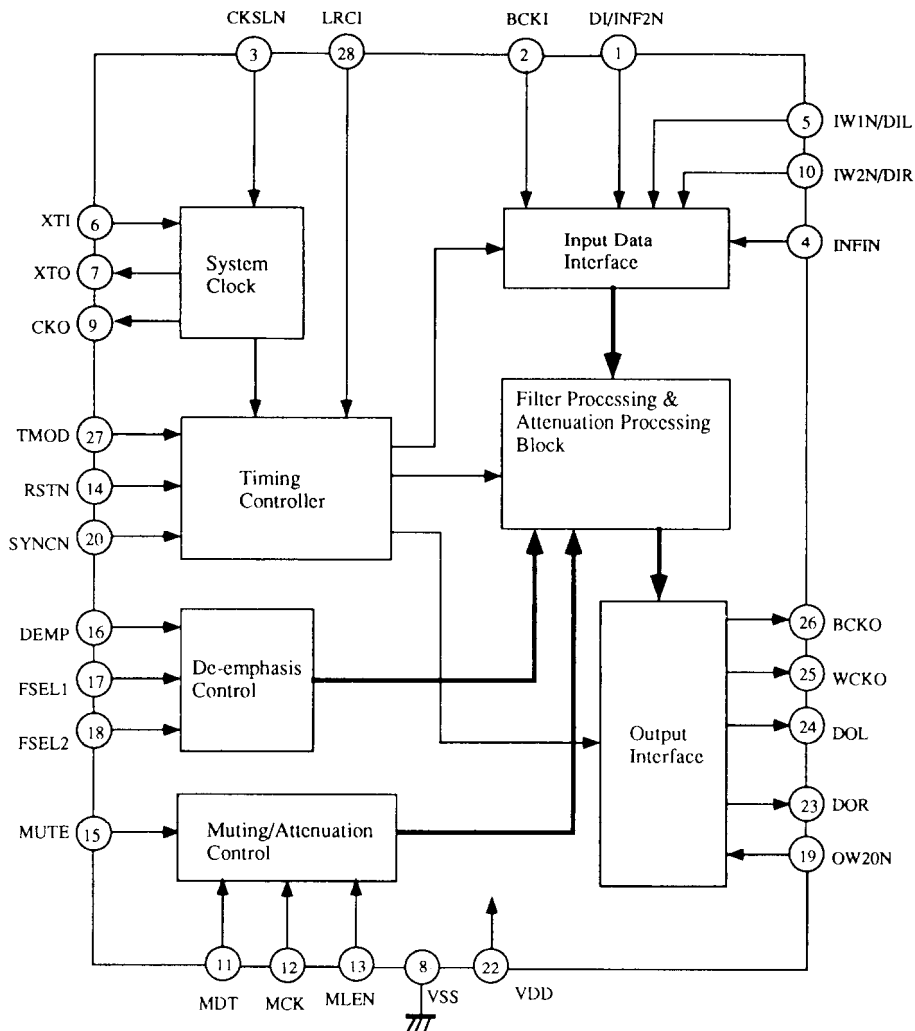

Data input	DI/INF2N	1	28	LRCI	Sample rate clock of input data
Bit clock input	BCKI	2	27	TMOD	Filter selector
Selector for resonator or input frequency	CKSLN	3	26	BCKO	Bit clock output
	INF1N	4	25	WCKO	Word clock output
	IW1N/DIL	5	24	DOL	L ch. data output
Clock input	XTI	6	23	DOR	R ch. data output
	XTO	7	22	VDD	
	VSS	8	21	NC	
Clock output	CKO	9	20	SYSCN	
	IW2N/DIR	10	19	OW2ON	
	MDT	11	18	FSEL2	
	MCK	12	17	FSEL1	
	MLEN	13	16	DEMP	DE-emphasis control ON:H
System reset Reset : L	RSTN	14	15	MUTE	Muting output Mute: H

AN8389SR

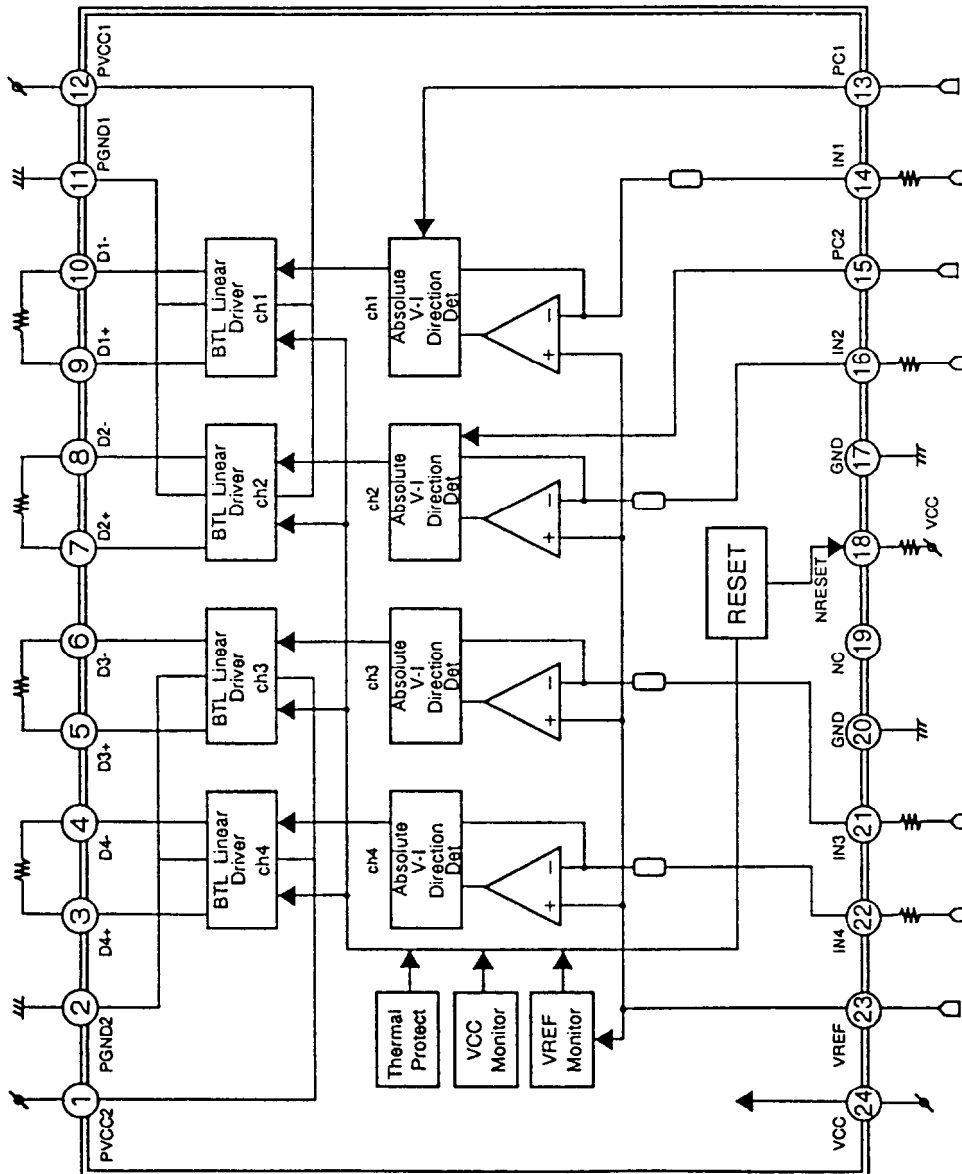

NO.	I/O	Description
1		Driver power terminal 2
2		Driver GND terminal 2
3	O	Motor driver 4 forward output terminal
4	O	Motor driver 4 reverse output terminal
5	O	Motor driver 3 forward output terminal
6	O	Motor driver 3 reverse output terminal
7	O	Motor driver 2 forward output terminal
8	O	Motor driver 2 reverse output terminal
9	O	Motor driver 1 forward output terminal
10	O	Motor driver 1 reverse output terminal
11		Driver power terminal 2
12		Driver power terminal 1
13	I	PC1(Power cut) input terminal
14	I	Motor driver 1 input terminal
15	I	PC2(Power cut) input terminal
16	I	Motor driver 2 input terminal
17		GND
18	O	Reset output terminal
19		GND
20		GND
21	I	Motor driver 3 input terminal
22	I	Motor driver 4 input terminal
23	I	VREF input terminal
24		Power terminal

MICROPROCESSOR TERMINAL DESCRIPTION

Pin No.	Symbol	I/O	Description
1~5	P94~P90/FIP6~FIP2	O	FL TUBE GRID OUTPUT
6~7	P81~P80/FIP1~FIP0		
8	VDD	I	POWER TERMINAL
9	P27/SCK0	O	COMMAND FORWARD CLOCK OUTPUT TERMINAL FOR SIGNAL PROCESS IC
10	P26/SO0/SB1	O	COMMAND DATA OUTPUT TERMINAL FOR SIGNAL PROCESS IC
11	P25/SI0/SB0	I	SENSE SIGNAL INPUT TERMINAL FROM SIGNAL PROCESS IC
12	P24/BUSY	O	COMMAND FOR SIGNAL PROCESS IC · RATCH OUTPUT TERMINAL
13	P23/STB	O	AUDIO OUTPUT MUTE SIGNAL OUTPUT TERMINAL
14	P22/SCK1	O	SUBCODE FORWARD CLOCK OUTPUT TERMINAL FOR SIGNAL PROCESS IC
15	P21/SO1	I	STATUS INPUT TERMINAL FROM SIGNAL PROCESS IC
16	P20/SI1	I	SUBCODE INPUT TERMINAL FROM SIGNAL PROCESS IC
17	RESET	I	RESET SIGNAL INPUT TERMINAL
18	P74	I	NOT USED. (CONNECTED TO GND)
19	P73	I	NOT USED. (CONNECTED TO GND)
20	AVSS	I	A/D CONVERTER POWER GND FOR KEY INPUT
21	P17/ANI7	O	SYSTEM SIGNAL OUTPUT TERMINAL
22	P16/ANI6	I	SYSTEM SIGNAL INPUT TERMINAL
23	P15/ANI5	I	NOT USED. (CONNECTED TO GND)
24	P14/ANI4	O	SIGNAL PROCESS IC RESET OUTPUT TERMINAL
25	P13/ANI3	O	FL TUBE POWER CONTROL TERMINAL
26	P12/AM12	O	T-MOD CONTROL TERMINAL
27	P11/AM11	I	KEY INPUT TERMINAL 2
28	P10/AM10	I	KEY INPUT TERMINAL 1
29	AVDD	I	A/D CONVERTER POWER TERMINAL FOR KEY INPUT
30	AVREF	I	A/D CONVERTER REFERENCE POWER TERMINAL FOR KEY INPUT
31	P04/XT1	I	NOT USED. (CONNECTED TO GND)
32	XT2		NOT USED.
33	VSS	I	POWER GND
34	X1	I	CLOCK OSCILLATE CIRCUIT INPUT TERMINAL
35	X2	O	CLOCK OSCILLATE CIRCUIT OUTPUT TERMINAL
36	P37	I	NOT USED. (CONNECTED TO GND)
37	P36/BUZ	I	NOT USED. (CONNECTED TO GND)
38	P35/PCL	O	MOTOR VOLUME CONTROL TERMINAL
39	P34/TI2	O	
40	P33/TI1	O	TRAY MOTOR CONTROL TERMINAL
41	P32/TO2	O	
42	P31/TO1	O	TRAY OPEN DETECTION TERMINAL
43	P30/TO0	O	TRAY CLOSE DETECTION TERMINAL
44	P03/INTP3/CIO	I	FOCUS LOCK SIGNAL FROM SIGNAL PROCESS IC INPUT TERMINAL
45	P02/INTP2	I	POWER DETECTION TERMINAL
46	P01/INTP1	I	SUBCODE BLOCK FROM SIGNAL PROCESS IC DETECTION SIGNAL INPUT TERMINAL
47	P00/INTPO/TIO	I	REMOTE SENSOR SIGNAL INPUT TERMINAL
48	IC	I	MICROPROCESSOR INTERNALY CONNECT TERMINAL (CONNECTED TO GND)
49	P72	I	NOT USED. (CONNECTED TO GND)
50	P71	I	NOT USED. (CONNECTED TO GND)
51	P70	I	NOT USED. (CONNECTED TO GND)
52	VDD	I	POWER TERMINAL
53	P127/FIP33	I	NOT USED. (CONNECTED TO GND)
54	P126/FIP32	I	NOT USED. (CONNECTED TO GND)
55~60	P125~P120/FIP31~FIP26	O	FL TUBE SEGMENT OUTPUT TERMINAL
61~68	P117~P110/FIP25~FIP18		
69~70	P107~P106/FIP17~FIP16		
71	VLOAD	I	NEGATIVE POWER SUPPLY TERMINAL FL TUBE
72~77	P105~P100/FIP15~FIP10	O	FL TUBE GRID OUTPUT
78~80	P97~P95/FIP9~FIP7		

IC BLOCK DIAGRAM AND DESCRIPTION
MN662720RB

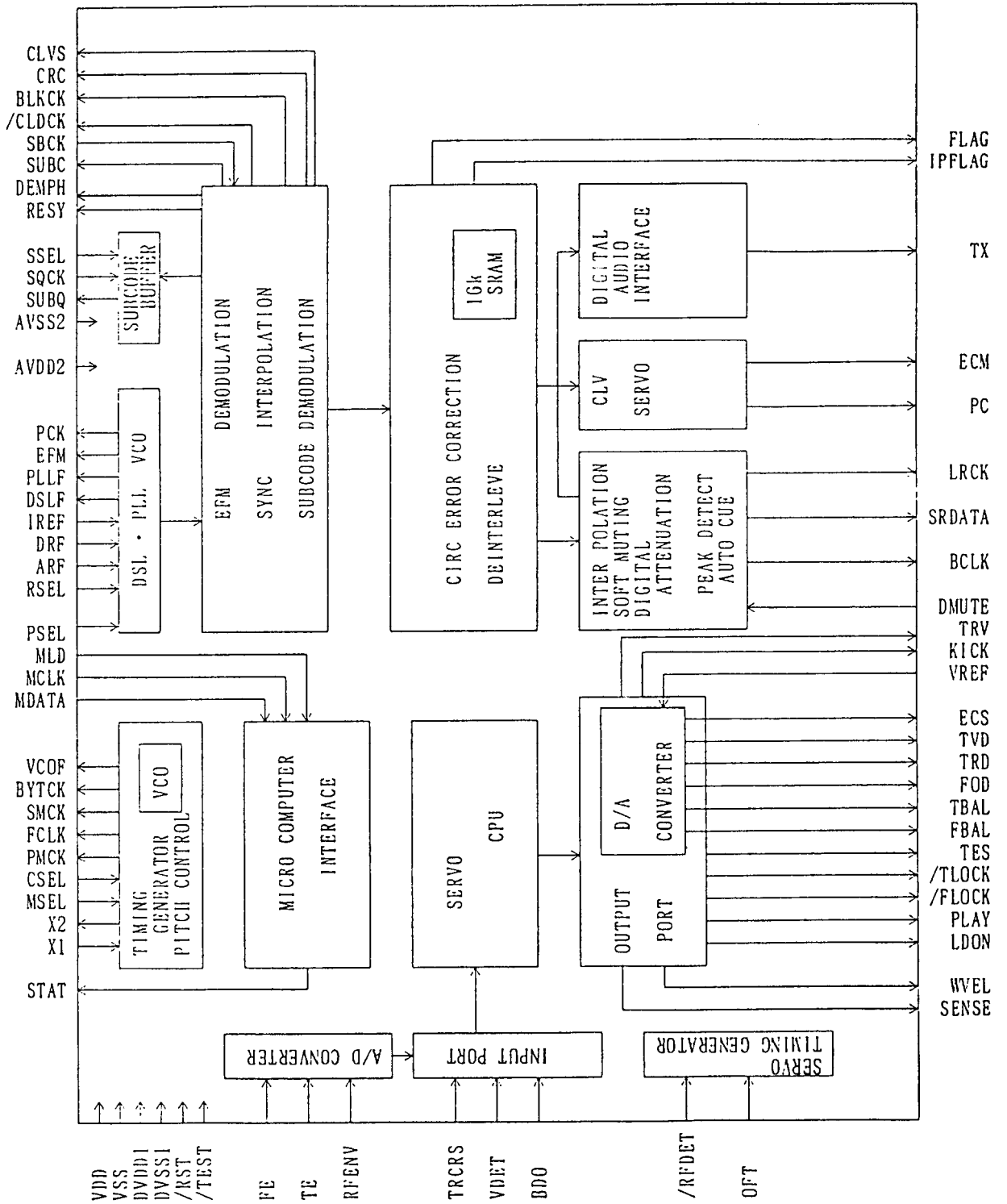

NO.	I/O	Description	NO.	I/O	Description
1	BCLK	Bit clock output for SRDATA	41	TES	Tracking error shunt signal input
2	LRCK	L,R Detection signal output	42	PLAY	Play signal output
3	SRDATA	Serial data output	43	WVEL	Hi-speed status signal output
4	DVDD1	Power for digital circuit	44	ARF	RF signal input
5	DVSS1	GND for digital circuit	45	IREF	Reference current input terminal
6	TX	Digital audio interface output signal	46	DRF	DSL bias terminal
7	MCLK	Microprocessor command clock signal input	47	DSLFL	DSL loop filter terminal
8	MDATA	Microprocessor command data input	48	PLLFL	PLL loop filter terminal
9	MLD	Microprocessor command load signal output	49	VCOF	VCO loop filter terminal
10	SENSE	Sense signal input	50	AVDD2	Power for analog circuit
11	/FLOCK	Focus servo signal	51	AVSS2	GND for analog circuit
12	/TLOCK	Tracking servo signal	52	EFM	EFM signal output
13	BLKCK	Sub code block clock signal	53	PCK	PLL extraction clock output
14	SQCK	External clock input for sub code Q register	54	PDO	Phase comparator signals output of EFM signal and PCK signal
15	SUBQ	Sub code Q code output	55	SUBC	Sub code serial output data output
16	DMUTE	Muting input	56	SBCK	Sub code serial output clock output
17	STAT	Status signal	57	VSS	GND for oscillation circuit
18	/RST	Reset input	58	X1	Crystal oscillation circuit input terminal
19	SMCK	MSEL=H 8.4672MHz clock signal output	59	X2	Crystal oscillation circuit output terminal
20	PMCK	MSEL=L 4.2336MHz clock signal output	60	VDD	Power for oscillation circuit
21	TRV	88.2kHz clock signal output	61	BYTCK	Bite clock output
22	TVD	Traverse enforcement output	62	/CLDCK	Sub code frame clock signal output
23	PC	Traverse drive output	63	FCLK	Crystal frame clock output
24	ECM	Spindle motor ON signal	64	IPFLAG	Interpolation flag output
25	ECS	Spindle motor drive signal (servo mode output)	65	FLAG	Flag output
26	KICK	Spindle motor drive signal (servo error signal output)	66	CLVS	Spindle servo phase synchronize signal output
27	TRD	Kick pulse output	67	CRC	Subcode CRC check output
28	FOD	Tracking drive output	68	DEMPH	Deemphasise detection signal output
29	VREF	Focus drive output	69	RESY	SSEL = L FLAG6 output
30	FBAL	Reference voltage for DA output	70	NC1	No connection terminal
31	TBAL	Focus balance adjustment output	71	/TEST	Test terminal
32	FE	Tracking balance adjustment output	72	AVDD1	Power for digital circuit
33	TE	Focus error signal input (analog input)	73	NC2	No connection terminal
34	RFENV	Tracking error signal input (analog input)	74	AVSS1	GND for digital circuit
35	VDET	RF envelope signal input	75	NC3	No connection terminal
36	OFT	Vibration detection signal input	76	RSEL	No connection terminal
37	TRCRS	Off track signal input	77	CSEL	RF signal pole specified terminal
38	/RFDET	Track cross signal input	78	PSEL	Crystal oscillation frequency specified terminal
39	BDO	RF detection signal input	79	MSEL	Test terminal
40	LDON	Dropout signal input	80	SSEL	SMCK terminal
		Laser ON signal output			SUBQ terminal

AN8806SB

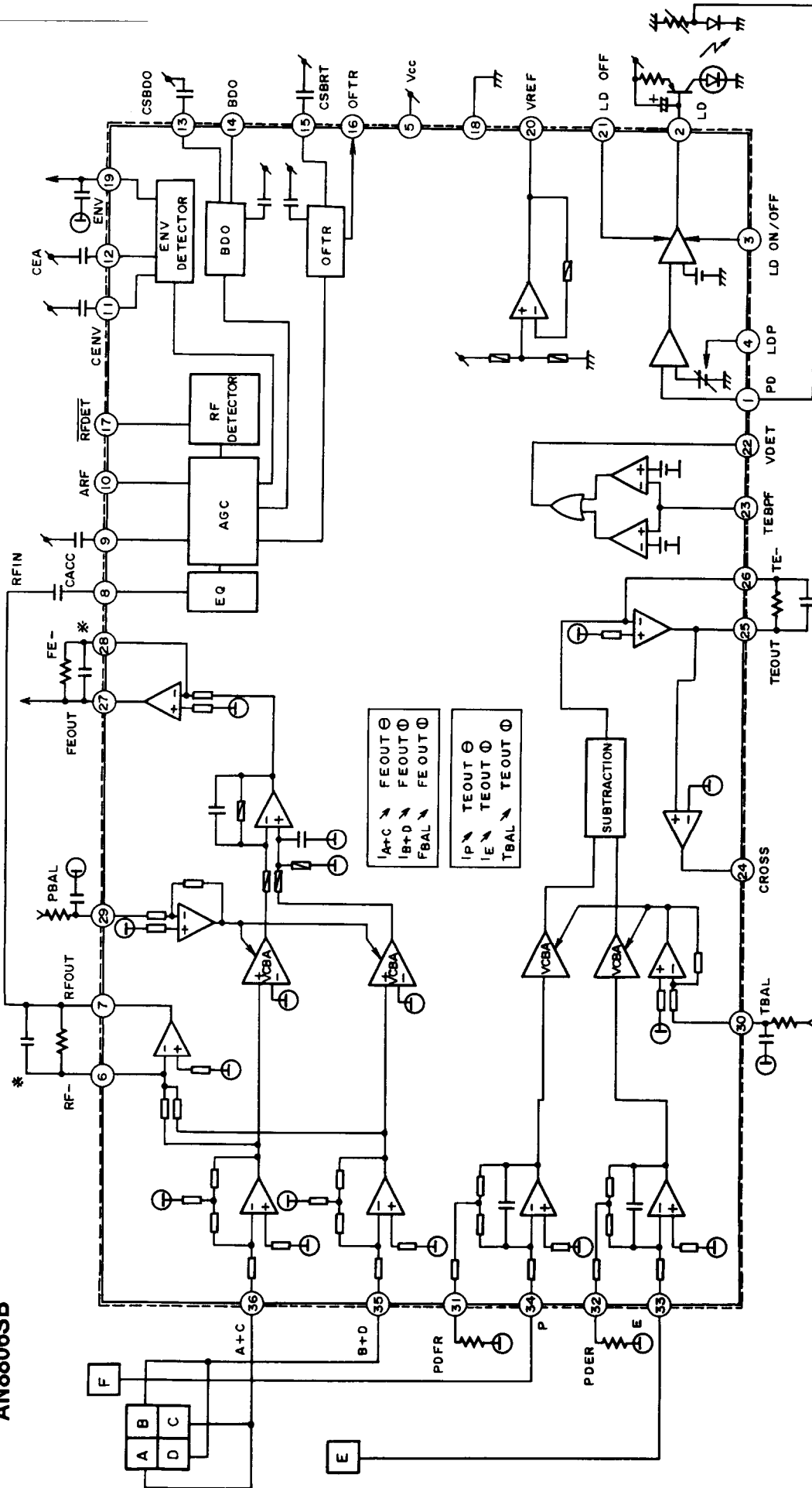

NO.	I/O	Description
1	I	APC Amp input terminal
2	O	APC Amp output terminal
3	O	APC ON/OFF control terminal
4		APC reference terminal
5		Power terminal
6	I	RF Amp reverse input terminal
7	O	RF Amp output terminal
8	I	AGC input terminal
9		AGC loop filter terminal
10	O	AGC output terminal
11		RF detector terminal
12		HPF-Amp terminal
13		RF dark side envelope detector terminal
14	O	BDO output terminal
15		RF light side envelope detector terminal
16	O	OFTR output terminal
17	O	RFDET output terminal
18		GND
19	O	3TENV output terminal
20	O	VREF output terminal
21	O	APC OFF control terminal
22	O	VDET output terminal
23	I	VDET input terminal
24	O	CROSS output terminal
25	O	TE.Amp output terminal
26	I	TE.Amp reverse input terminal
27	O	FE.Amp output terminal
28	I	FE.Amp reverse input terminal
29	O	F.BAL control terminal
30	O	T.BAL control terminal
31		I-V Amp convert resistor adjustment terminal
32		I-V Amp convert resistor adjustment terminal
33	I	I-V Amp input terminal
34	I	I-V Amp input terminal
35	I	I-V Amp input terminal
36	I	I-V Amp input terminal

CAUTION ON REPLACEMENT OF PICKUP

The laser diode in the optical pickup block is so sensitive to static electricity, surge current and etc. that the components are liable to be broken down or its reliability remarkably deteriorated.

During repair, carefully take the following precautions.

1. When replacing the optical pickup, first short the LD terminals and remove the connector. Also, when attaching the new optical pickup, after attaching the connector, unsolder the LD terminals.
2. Do not touch the optical pickup object lens with the hands.

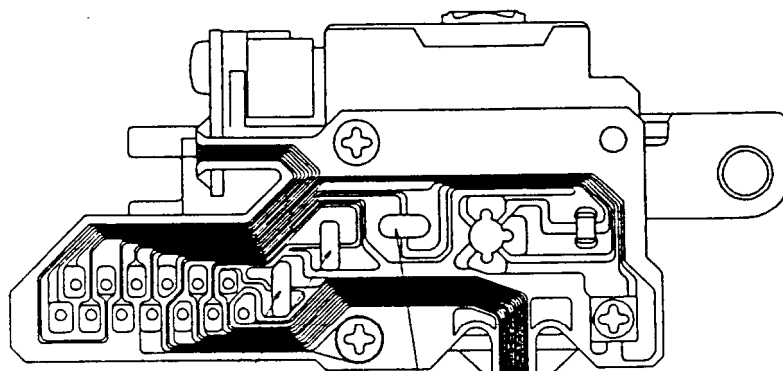

Short pattern for LD protection.

ADJUSTMENT PROCEDURE

Instrument required

Dual trace oscilloscope, Frequency counter, AF oscillator, Test disc (SONY YEDS-18), AC voltmeter, and Socket P4 (Part no. 25050138)

1. Slide Balance Adjustment

1. Connect the audio oscillator to P154 SLD and the oscilloscope to P154 SLD and VS as shown bellow.
 2. Set the output of oscillator to the square wave, 5Hz, 2Vp-p.
 3. Turn the switch S151 to OPEN.
 4. Turn the power switch to ON.
 5. Confirm that the optical pickup does not move. (If it moves, control it by hand.)
 6. Adjust the semi-fixed resistor R139 so that the waveformers of channels 1 and 2 become the same phase.
- After adjustment, remove the audio oscillator and oscilloscope.

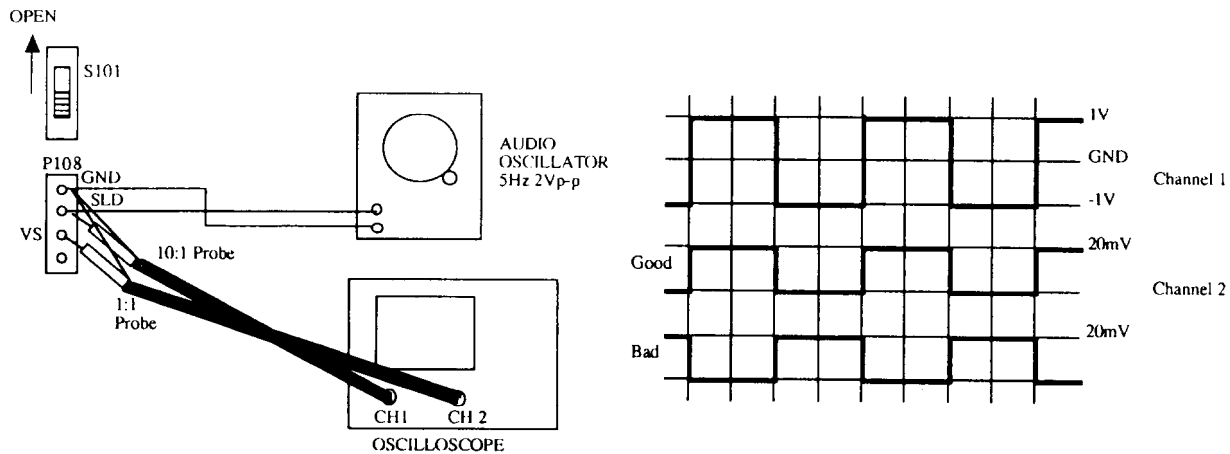

2. Slide Offset Adjustment

1. Connect the oscilloscope to P154 SLD.
2. Turn S151 to SHORT.
3. Adjust the semi-fixed resistor R175 so that the waveform on the oscilloscope becomes 0V.

3. confirmation of Jitter

1. Connect the jitter meter to P155, and confirm the jitter value is less than 14nSec.

4. Auto Adjustment

1. If you push the [UP] button and [DISPLAY] button together when the power switch turns ON,
2. Insert the disc and closed by [OPEN/CLOSE] button, the disc will read in and autoadjustmen will start. you can enter to the Test mode.

When the autoadjustmen finished, disc's information will displayed.

At times error message (Er Fg, Er Fe) will displayed, but it is not bud condition.

Push the [OPEN/CLOSE] button and [DIGITAL OUT] button together When the power ON no disc condition, you will cancel the test mode.

PRINTED CIRCUIT BOARD-PARTS LIST

MAIN CIRCUIT PC BOARD (NAAR-5645)

CIRCUIT NO.	PART NO.	DESCRIPTION
	ICS	
Q101	22240925	MN662720RB
Q102	222755	TC74HCU04P
Q301	22240913R3	SM5844AF
Q302	22240680-1	SM5843AP
Q303,Q304	22240963	SM5864AP
Q305	222755	TC74HCU04P
Q401-Q406	22240965	OPA2604AP
Q407-Q410	22240656	NE5532AN
Q411,Q412	22240191	NJM4565D-D
Q751	22240322	LB1639
Q910,Q913,Q914	222780125	78M12HF
Q911,Q912	222780055	78M05HF
Q915,Q916	222780053	78L05

TRANSISTORS

Q306,Q601	2213570 or 221281 or 2214930	RN1207 or DTC114YS or UN4214
Q602	2211945	2SK246-GR
Q603	2211706 or 2211705	2SD655-F or 2SD655-E
Q752,Q753	2213570 or 221281 or 2214930	RN1207 or DTC114YS or UN4214
Q901,Q902,Q905	2211945	2SK246-GR
Q903	2213284 or 2211183 or 2211255	2SC1740S-R or 2SC1740-R or 2SC1815-GR
Q904,Q906	2211455	2SA1015-GR
Q907	2201285 or 2201286	2SD882-Q or 2SD882-P
Q908	2201275 or 2201276	2SB772-Q or 2SB772-P
Q909	2202706	2SD2394-F

OPTICAL MODULE

Q103	24120038	GP1F32T
D601,D602	223222 or 223205 or 223163	WG713A or 1SS270A or 1SS133
D913,D914	224470512	MTZJ5.1B, Zener
D915	224470823	MTZJ8.2C, Zener

CRYSTAL,HOLDERS

X101	3010159	AT-38-169
X301	3010262	XTL-20.00M
X101A	27190751	HOLDER
X301A	27190751	HOLDER

COIL,RELAY

L101	232136	NSRF-2046
RL601,RL602	25065469	NRL-2P1A-DC12-078

CAPACITORS

C433-C436	393341027	CE04W16V, 1000M, VX C
C939,C940,C947	393342227	CE04W16V, 2200M, VX C
C950,C984,C996	393342227	CE04W16V, 2200M, VX C
C999	393342227	CE04W16V, 2200M, VX C

RESISTORS

R912	442723304F	RS2WBJ, 33, METAL O R
R913	443622704	RS1WBJ, 27, METAL O R

CIRCUIT NO.

CIRCUIT NO.	PART NO.	DESCRIPTION
	SOCKETS	
P153B	25050970	NSCT-30P757, SOCKET
P701B	25050967	NSCT-27P754, SOCKET
P905A	2009990400	NSAS-16P0537, SOCKET AS
P907A	2009990401	NSAS-6P0538, SOCKET AS
P907B	2009990401	NSAS-6P0538, SOCKET AS

TERMINALS

P101	25045237	NPJ-1PDOR111, PIN JACK
P401	25045429	NPJ-2PDBL254, PIN JACK
P402	25045422	NPJ-2PDBL247, PIN JACK

WIRE HOLDERS

P405A,P405B	25051107	NSCT-3P894, WIRE HOLDER
P406A,P406B	25051107	NSCT-3P894, WIRE HOLDER
P407A,P407B	25051107	NSCT-3P894, WIRE HOLDER

PLUGS

P403	25055153	NPLG-9P137, PLUG
P905	25055171	NPLG-8P155, PLUG
P906A	25055143	NPLG-13P127, PLUG

OTHERS

P404	2065525160UL	CRIMP AS
P702	25050267	NSCT-3P95, WIRE TRAP
P751	25045330	NPJ-2PDBL184, ST JACK
E102	25065425	SCREW TRMM3
E103,E104	27141059	END PLATE

POWER SUPPLY CIRCUIT PC BOARD (NAPS-5646)

CIRCUIT NO.	PART NO.	DESCRIPTION
	DIODES	
D901	22380048	RBA-402
D902-D912	22380035 or 22380032	GP104003E or 1SR139-100

CAPACITORS

C907,C908	△ 3504261	CE92W50V, 10000M, ELECT C
C912,C919,C920	393342227	CE04W16V, 2200M, VX C

PLUGS

P903	25055135	NPLG-5P119, PLUG
P904	25055136	NPLG-6P120, PLUG

SWITCH PC BOARD (NASW-5651)

CIRCUIT NO.	PART NO.	DESCRIPTION
	SWITCH	
S901	△ 25035636	NPS-111-L590P, PUSH SWITCH

MECHA DRIVE CIRCUIT PC BOARD (NADIS-5650)

CIRCUIT NO.	PART NO.	DESCRIPTION
	ICS	
Q151	22240924	AN8806SB
Q152	22240927	AN8389SR
Q153	22240620	LA6520
Q154	222090	S2FR04
Q953	222780055	78M05HF
	TRANSISTORS	
Q155	2211504 or 2211503	2SA950-Y or 2SA950-O
Q951	2211504 or 2211503	2SA950-Y or 2SA950-O
Q952	2211164	2SC2120-Y
Q954	2211504 or 2211503	2SA950-Y or 2SA950-O
Q955,Q956	2211455	2SA1015-GR
Q957,Q958	2211164	2SC2120-Y
Q959	2211454	2SA1015-Y
Q960	2202705	2SD2394-E

CIRCUIT NO.	PART NO.	DESCRIPTION
D151	DIODES 223222 or 223205 or 223163	WG713A or 1SS270A or 1SS133
D951,D952 D953 D954,D955	224471103 224473004 22380035 22380032	MTZJ11C, Zener MTZJ30D, Zener GP104003E 1SR139-100
D956	224470753 223205 223163	MTZJ7.5C, Zener 1SS270A 1SS133
L151 X701	CRYSTAL, COIL 233454K100T 3010229T	NCH-1452 100K, CHOKE COIL EFOEC4004A4, CERA LOCK
R174 R175 R482	RESISTORS 5210002 5210064 5142020	N06HR 150BDM, TRIMMER N06HR 10KBD, TRIMMER N16RGM 20KB30F, VARIABLE
S151	SWITCH 25065364	NSS-12138, SLIDE SWITCH
P151 P153A P906B	SOCKETS 25050958 25050970 2001292625	NSCT-18P745, SOCKET NSCT-30P757, SOCKET NSAS-26P0546, SOCKET AS
P152 P154 P155	PLUGS 25055149 25055045 25055042	NPLG-5P133, PLUG NPLG-4P33, PLUG NPLG-3P32, PLUGS
JL452A Q702B J1	OTHERS 25051107 27190778A 2061513120	NSCT-3P894, WIRE HOLDER HOLDER(DIS) CRIMP AS
DISPLAY CIRCUIT PC BOARD (NADIS-5649-1)		
CIRCUIT NO.	PART NO.	DESCRIPTION
Q701 Q707 Q703 Q704-Q706 Q709	ICS 22241028 22240018 2212600 2211164 221282	μPD78043AGF-051 M51943A DTA124ES 2SC2120-Y DTC144ES
Q702	FL TUBE 212149	16-MT-53GK
D702,D704	DIODES 223222 or 223205 or 223163	WG713A or 1SS270A or 1SS133
D701 D703 D705	224470623 224470562 223222 or 223205 or 223163	MTZJ6.2C, Zener MTZJ5.6B, Zener WG713A or 1SS270A or 1SS133
D706	223222	WG713A
R722 R723	RESISTORS 49163104416 49163104416	RM1/10J 100K×16, R NET RM1/10J 100K×16, R NET
S701-S711	SWITCHES 25035652	NPS-111-S604, NPS-111-S624, PUSH SWITCH

CIRCUIT NO.	PART NO.	DESCRIPTION
P701A P703A P704A	OTHERS 25050933 25050280 25051107	NSCT-27P720, SOCKET NSCT-3P108, WIRE TRAP NSCT-3P894, WIRE HOLDER
HEADPHONE AMPLIFIER CIRCUIT PC BOARD (NAAF-5647)		
CIRCUIT NO.	PART NO.	DESCRIPTION
Q451	IC 22240369	M5218AP
R481	RESISTOR 5142020	N16RGM 20KB30F, VARIABLE
P403A	SOCKET 2009990399A	NSAS-18P0536
P702A	WIRE HOLDER 25051107	NSCT-3P894
HEADPHONE JACK PC BOARD (NAAF-5648)		
CIRCUIT NO.	PART NO.	DESCRIPTION
P451	HP JACK 25045221	HLJ0540-01-410, HP JACK
JL452B	WIRE HOLDER 25051107	NSCT-3P894
REMOTE SENSOR PC BOARD (NAETC-5657)		
CIRCUIT NO.	PART NO.	DESCRIPTION
Q708	REMOTE SENSOR 241302	PIC-12043TH2
P703B	WIRE HOLDER 25051107	NSCT-3P894
INDICATOR PC BOARD (NADIS-5652)		
CIRCUIT NO.	PART NO.	DESCRIPTION
D751	DIODE 225324D or 225324C	SEL6910A-D, LED or SEL6910A-C, LED
P704B	WIRE HOLDER 25051107	NSCT-3P894
MECHA PC BOARD (NAETC-5653-1)		
CIRCUIT NO.	PART NO.	DESCRIPTION
P1 P2 P3A	SOCKETS 25051583 25051651 25050868	NSCT-13P1370 NSCT-18P1438 NSCT-4P663

NOTE: THE COMPONENTS IDENTIFIED BY MARK ARE CRITICAL FOR RISK OF FIRE AND ELECTRIC SHOCK. REPLACE ONLY WITH PART NUMBER

PACKING VIEW

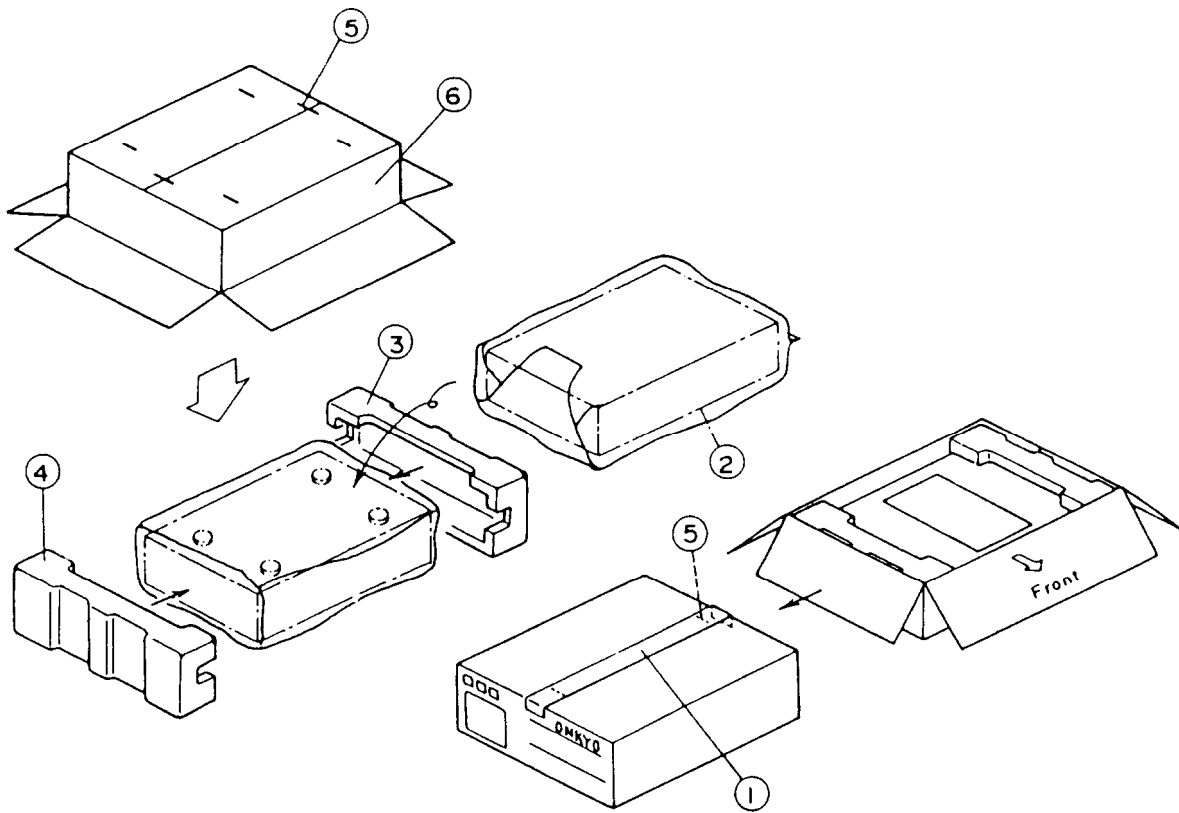

REF NO.	PART NO.	DESCRIPTION	ACCESSORY BAG AS
1	29110071	PP TAPE	2010238 CORD AS
2	29100105	POLY BAG	2010200 3.5MINI PLUG, CORD AS
3	29091715	PAD (L)	24140308 RC-308C, REMOTE CONTROLLER
4	29091716	PAD (R)	3010054 UM-3, BATTERY
5	282301	STAPLE	29355244 INSTRUCTION SHEET (L)
6	29052961	CARTON <S>	29342264 INSTRUCTION MANUAL (E)
	29052960	CARTON 	29342266 INSTRUCTION MANUAL (U6) <P (without E)>
	29052962	CARTON <G>	29342265 INSTRUCTION MANUAL (U3) <C,W,T>
	29361937	LABEL (L)	29342267 INSTRUCTION MANUAL (T) <W>
	29360687	LABEL (CLASS1) <P,W>	25055040 CV-K-2, CV PLUG <W>
	29361935	LABEL (UPC) <D>	29100097-1AY 320×250, POLY BAG
	29361947	LABEL (UPC) <GN>	29365019A WARRANTY CARD <N>
	29360404	SHEET	29358002J SERVICE STATION LIST <N>

<S> : Silver model only
 : Black model only
 <G> : Golden model only
 <D> : 120V model only
 <P> : 230V model only
 <W> : Worldwide model only
 <N> : American model only
 <C> : Canadian model only
 <E> : British model only
 <A> : Australian model only
 <T> : Taiwanese model only
 <GN> : American golden model only