

# ONKYO SERVICE MANUAL

## COMPACT DISC AUTOMATIC CHANGER

### MODEL DX-C201

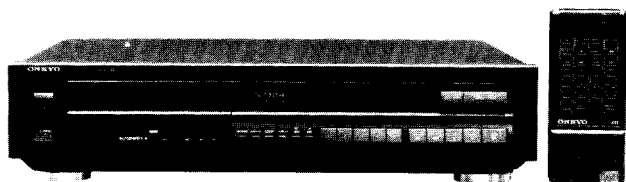

### MODEL DX-C101

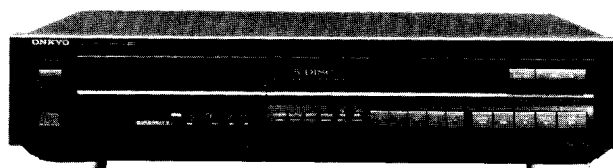

### SAFETY-RELATED COMPONENT WARNING!!

COMPONENTS IDENTIFIED BY MARK  $\triangle$  ON THE SCHEMATIC DIAGRAM AND IN THE PARTS LIST ARE CRITICAL FOR RISK OF FIRE AND ELECTRIC SHOCK. REPLACE THESE COMPONENTS WITH ONKYO PARTS WHOSE PART NUMBERS APPEAR AS SHOWN IN THIS MANUAL.

MAKE LEAKAGE-CURRENT OR RESISTANCE MEASUREMENTS TO DETERMINE THAT EXPOSED PARTS ARE ACCEPTABLY INSULATED FROM THE SUPPLY CIRCUIT BEFORE RETURNING THE APPLIANCE TO THE CUSTOMER.

### SPECIFICATIONS

#### ■ Audio

No. of channels:	2 (left and right, stereo)
Frequency response:	2–20,000 Hz $\pm$ 1 dB
Output voltage:	2V (at 0 dB)
Dynamic range:	96 dB
S/N ratio:	96 dB
Total harmonic distortion:	0.05% (1kHz, 0 dB)
Wow and flutter:	Below measurable limit
Output impedance:	1k $\Omega$
Load impedance:	More than 10k $\Omega$

#### ■ Signal Format

Sampling frequency:	176.4kHz 4 times over sampling
D-A conversion:	1 bit PWM/Accu-Pulse D/A converter

#### ■ Pickup

Wavelength:	780 nm
-------------	--------

#### ■ General

Power supply:	AC 60 Hz, 120V
Power consumption:	13W
Dimensions (W $\times$ H $\times$ D):	455 $\times$ 102.5 $\times$ 374 mm (17 <sup>15</sup> / <sub>16</sub> " $\times$ 4" $\times$ 14 <sup>11</sup> / <sub>16</sub> " )
Weight:	6.6kg (15.2 lbs)

Specifications are subject to change without notice.

**ONKYO**  
**AUDIO COMPONENTS**

# **TABLE OF CONTENTS**

Specifications .....	1
Before Use .....	3
Precaution of Laser Diode .....	4
Safety Precautions .....	4
Handling Precautions for Optical Pickup .....	5
Diassembling Procedures .....	6
Terminal Description of IC's .....	11
Internal Connection of FL .....	15
Troubleshooting Guide .....	16
Block Diagram .....	19
Printed Circuit Board – Parts List .....	22
Schematic Diagram .....	23
Wiring Connection Diagram .....	30
Printed Circuit Board Views .....	32
Packing View .....	35
Exploded View .....	36
Parts List .....	39
Adjustment Procedures .....	40

## BEFORE USE

### To release the transport lock

The optical pickup is secured to prevent damage during transport. Be sure to release it before use.

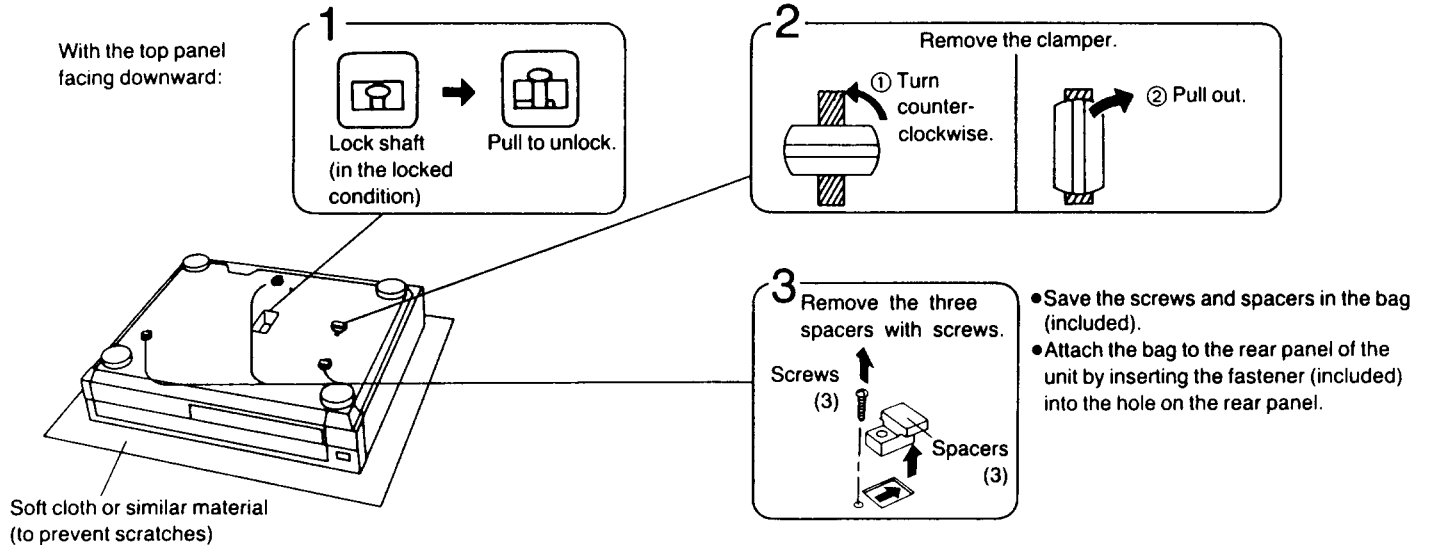

### Before transporting the unit

Be sure to lock the optical pickup according to the procedures below:

- ① Turn the power on and remove all discs from the trays.
- ② Close the loading drawer and turn the power off.
- ③ Place the unit with the top panel facing downward.
- ④ Insert the three spacers into the slots and secure them with the three screws.
- ⑤ Insert the clamber into the slot and turn it clockwise.
- ⑥ Place the unit with the right panel facing downward, and press the lock shaft to the Lock position (▲ - ▲).

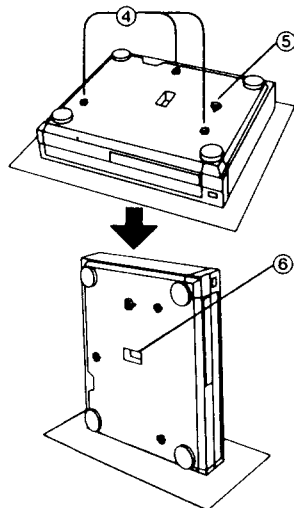

#### CAUTION:

- Do not transport the unit without locking the optical pickup. **SEVERE DAMAGE WILL RESULT.**
- Before tilting or transporting the unit, be sure to remove all discs from the trays. Otherwise, discs may possibly be fallen into the unit and can not be taken out.

### Placement notes

- Place on a flat, level surface so that the front-rear inclination does not exceed 5°.
- Avoid places such as the following:
  - Near any equipment or device that generates strong magnetism.
  - On any heat-generating equipment or device, or in any place where the temperature is high (40°C <104°F> or higher).
  - Extremely cold places (5°C <41°F> or below).
  - Near a tuner or TV (It may cause noise in the broadcast, or disturbance of the TV picture.)
  - For long periods of time in direct sunlight.
  - In dusty or smoky locations.
  - In locations prone to vibrations.
  - In locations where the rear panel is less than 10 cm (about 4") away from the wall or back of an audio rack.
  - Within reach of children.
- Do not place heavy objects, other than system components, on top of the unit.
- When carrying or storing the unit, handle it with care so it is not subjected to any strong bumps. Always remove the disc before storing the unit for any period of time.
- To avoid problems due to vibration.
  - Do not place a book or similar object under this unit.
  - Do not route the connection cables (of this or other units) across the operation panel, across the top, or under the unit.
- Do not push down on the loading drawer while it is opened. This may cause the unit to fall.

## PRECAUTION OF LASER DIODE

**CAUTION:** This unit utilizes a class 1 laser. Invisible laser radiation is emitted from the optical pick up lens when the unit is turned on:

1. Do not look directly into the pick up lens.
2. Do not use optical instruments to look at the pick up lens.
3. Do not adjust the preset variable resistor on the optical pick up.
4. Do not disassemble the optical pick up unit.
5. If the optical pick up is replaced, use the manufactures specified replacement pick up only.
6. Use of control or adjustments or performance of procedures other than those specified herein may result in hazardous radiation exposure.

## SAFETY PRECAUTION (This "safety precaution" is applied only in U.S.A.)

1. Before servicing, unplug the power cord to prevent an electric shock.
2. When replacing parts, use only manufacturer's recommended components for safety.
3. Check the condition of the power cord. Replace if wear or damage is evident.
4. After servicing, be sure to restore the lead dress, insulation barriers, insulation papers, shields, etc.
5. Before returning the serviced equipment to the customer, be sure to make the following insulation resistance test to prevent the customer from being exposed to a shock hazard.

### • INSULATION RESISTANCE TEST

1. Unplug the power cord and short the two prongs of the plug with a jumper wire.
2. Turn on the power switch.
3. Measure the resistance value with ohmmeter between the jumpered AC plug and each exposed metal cabinet part.

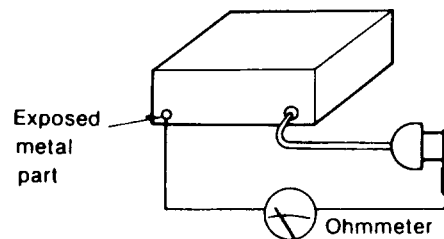

Resistance = Approx  $\infty$

4. If the measurement is outside the specified limits, there is a possibility of a shock hazard. The equipment should be repaired and rechecked before it is returned to the customer.

## HANDLING PRECAUTIONS FOR OPTICAL PICKUP

The laser diode in the optical pickup may break down due to potential difference caused by static electricity of clothes or human body.

So, be careful of electrostatic breakdown during repair of the optical pickup.

### • Handling of optical pickup

1. Do not subject the optical pickup to static electricity as it is extremely sensitive to electrical shock.
2. To prevent the breakdown of the laser diode, an anti-static shorting pin is inserted into the flexible board. (FPC board)  
When removing or connecting the short pin, finish the job in as short time as possible.
3. Take care not to apply excessive stress to the flexible board. (FPC board)
4. Do not turn the variable resistor (laser power adjustment). It has already been adjusted.

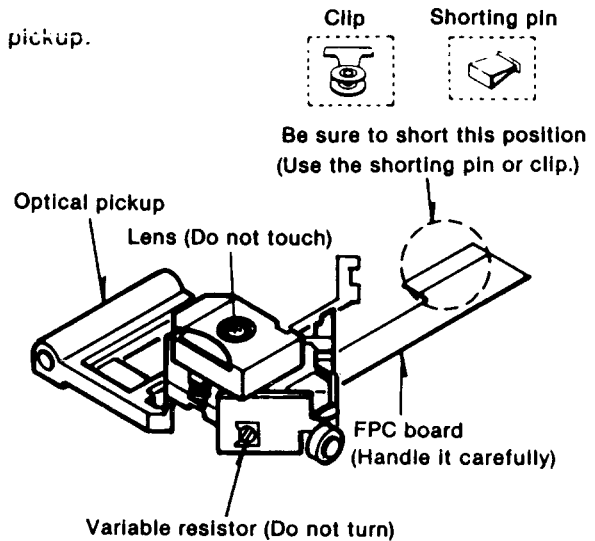

### • Grounding for electrostatic breakdown prevention

1. Human body grounding  
Use the anti-static wrist strap to discharge the static electricity from your body.
2. Work table grounding  
Put a conductive material (sheet) or steel sheet on the area where the optical pickup is placed, and ground the sheet.

#### Caution:

The static electricity of your clothes will not be grounded through the wrist strap. So, take care not to let your clothes touch the optical pickup.

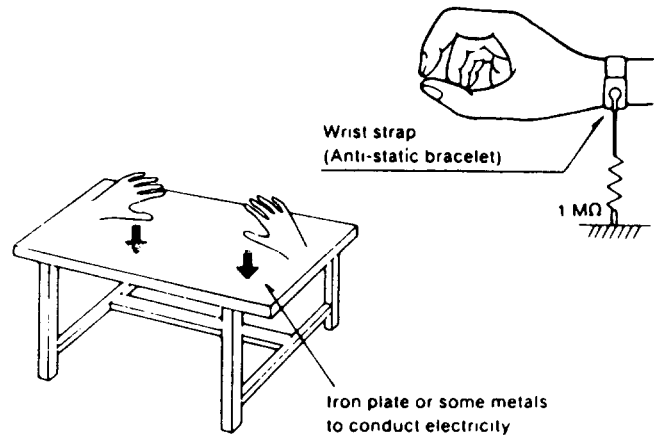

## INSTRUCTIONS FOR TRAVERSE OIL

The container contains 6g (approx. 3ml) of oil.  
One application (one shaft) uses 0.05ml of oil.

#### How to Use

- (1) Remove the guide shaft in the traverse deck from the optical pickup and clean off any dust from the guide shaft.
- (2) Apply one drop of the SZZOL31 to the tip of the guide shaft.
- (3) Hold the guide shaft so that its oiled end touches the optical pickup and insert it into the bearing while rotating it slowly.
- (4) After securing the guide shaft, move the optical pickup by hand several times to the left and right to distribute the oil on the guide shaft.

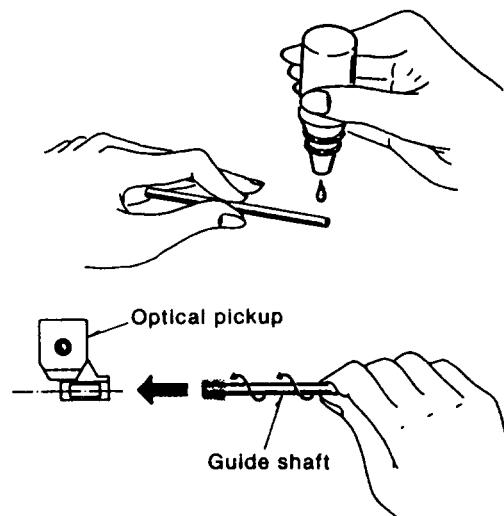

### “ATTENTION SERVICER”

Some chassis components may have sharp edges. Be careful when disassembling and servicing.

# DISASSEMBLY INSTRUCTIONS

**Warning:** This product uses a laser diodes. Refer to caution statements on page 4.

**ACHTUNG:**

- Die lasereinheit nicht zerlegen.
- Die lasereinheit darf nur gegen eine vom hersteller spezifizierte einheit ausgetauscht werden.

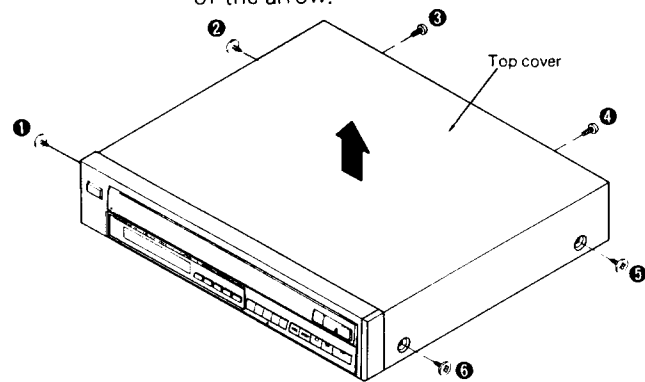
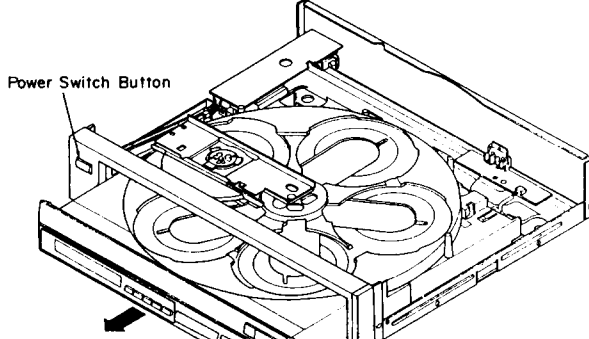
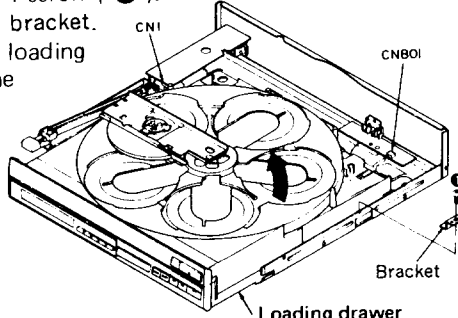
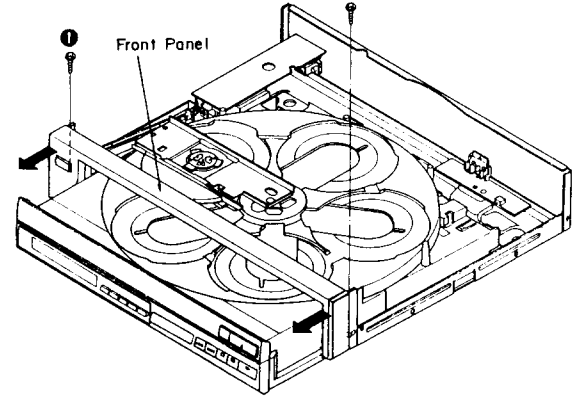
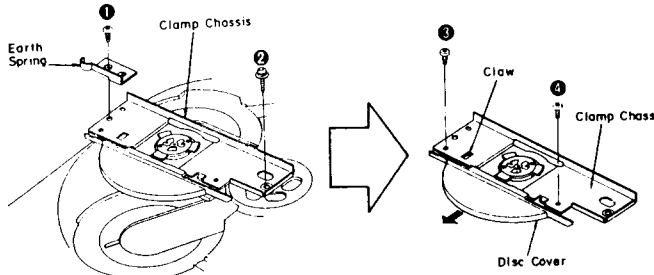
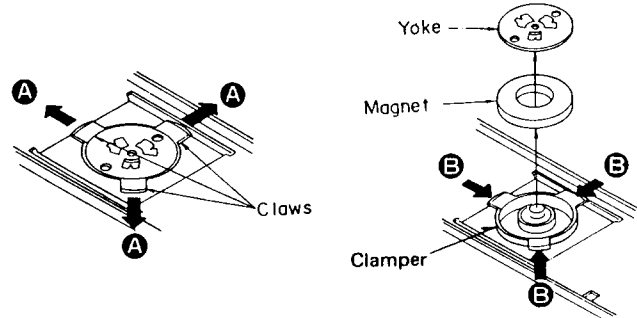
<p><b>Ref. No.</b> 1</p>	<p><b>Removal of the top cover</b></p>	<p><b>Ref. No.</b> 2</p>	<p><b>Removal of the front panel</b></p>
<p><b>Procedure</b> 1</p>	<p>1. Remove the 6 screws ( ❶ ~ ❺ ). 2. Remove the top cover in the direction of the arrow.</p> 	<p><b>Procedure</b> 1 → 2</p>	<p>1. Switch the player power ON. 2. Push the open/close button and pull out the loading drawer. 3. Switch the player power OFF.</p> 
<p><b>Ref. No.</b> 3</p>	<p><b>Removal of the loading drawer</b></p>		
<p><b>Procedure</b> 1 → 2 → 3</p>	<p>1. Switch the player power ON. 2. Push the open/close button and switch the player power OFF when pull out the loading drawer in the center of chassis as shown below. 3. Remove the 2 connectors (CN1, CN801). 4. Remove the 1 screw ( ❶ ). 5. Remove the bracket. 6. Remove the loading drawer in the direction of the arrow.</p> 	<p>4. Remove the 2 screws ( ❶ , ❷ ). 5. Remove the front panel in the direction of the arrow.</p>	
<p><b>Ref. No.</b> 4</p>	<p><b>Removal of the clamp chassis and disc cover</b></p>	<p><b>Ref. No.</b> 5</p>	<p><b>Removal of the yoke, magnet and clamp</b></p>
<p><b>Procedure</b> 1 → 4</p>	<p>1. Remove the 2 screws ( ❶ , ❷ ). 2. Remove the earth spring. 3. Remove the clamp chassis. 4. Remove the 2 screws ( ❸ , ❹ ). 5. Release the claw and pull out the disc cover.</p> 	<p><b>Procedure</b> 1 → 4 → 5</p>	<p>1. Push the claws of clammer in the direction of the arrow <b>A</b> and remove the yoke and magnet. 2. Push the claws of clammer in the direction of the arrow <b>B</b> and remove the clammer.</p> 

**Ref. No. 6**      **Removal of the disc tray**

**Procedure**  
1→2→4→6

1. Release the claw and remove the tray holder in the direction of the arrow **A**.

2. Remove the tray holder in the direction of the arrow **B**.

**Ref. No. 7**      **Removal of the power source P.C.B., power transformer and power switch rod**

**Procedure**  
1→2→3→7

1. Remove the power switch rod by using a screwdriver.

**Ref. No. 8**      **Removal of the shield plate**

**Procedure**  
1→2→3→8

- Remove the 6 screws ( ① ~ ⑥ ).

Shield Plate

2. Remove the 3 screws ( ① ~ ③ ).

3. Remove the 1 connector (CN 1).

Power Switch Rod

Unsolder the terminals

Power Transformer

4. Unsolder the terminals of the power transformer.

**Ref. No. 9**      **Removal of the operation panel**

**Procedure**  
1→2→3→8→9

1. Remove the 2 screws. ( ① ~ ② ).

Rib

Bracket

Rib

Operation Panel

2. Remove the bracket from the rib.

3. Remove the operation panel in the direction of the arrow.

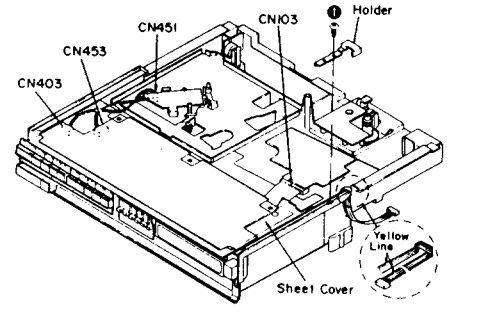
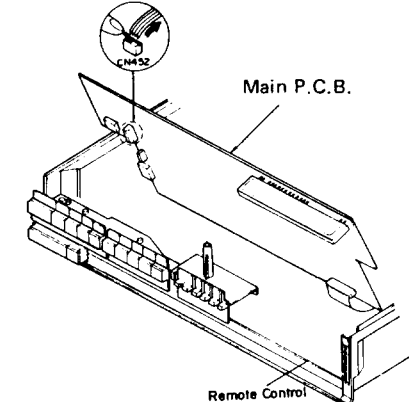
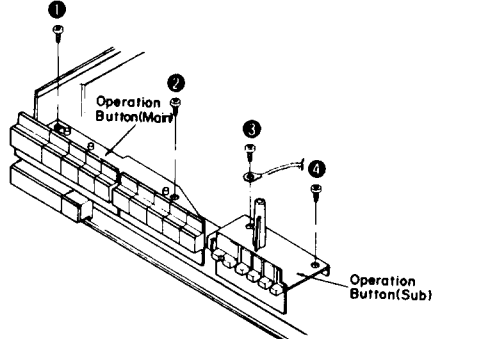
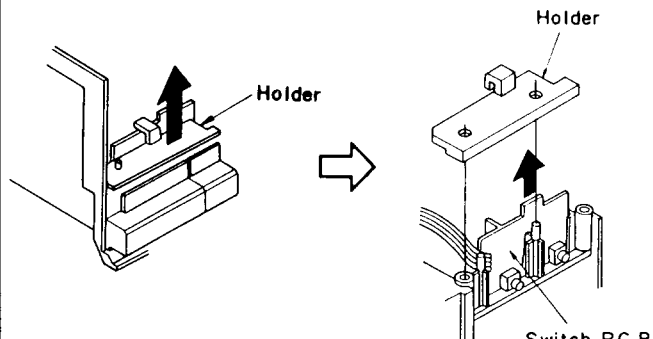
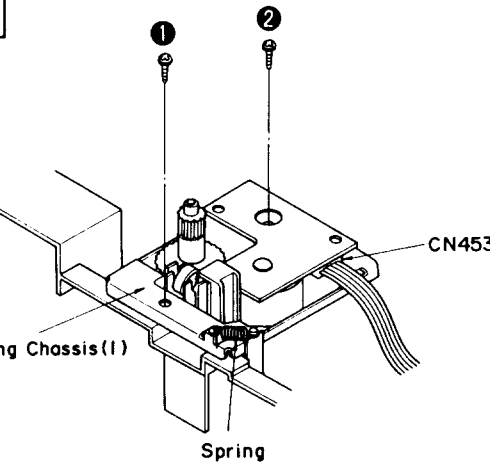
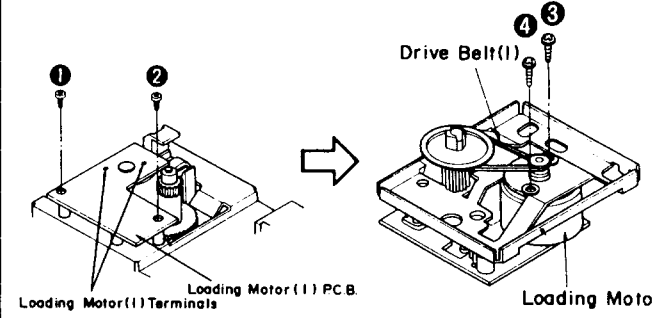
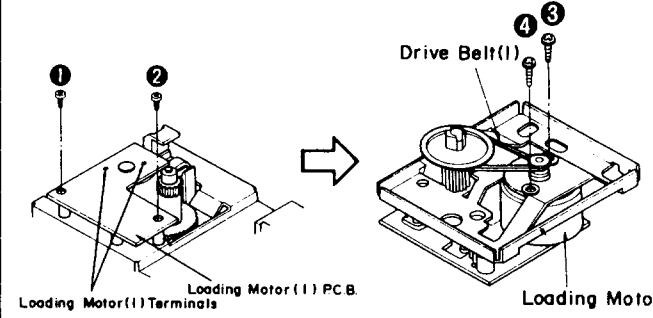
<p><b>Ref. No. 10</b></p>	<p><b>Removal of the main P.C.B.</b></p>	<p>4. Remove the 3 connectors (CN403, CN451, CN453). 5. Remove the 2 flat cables (CN103, CN452). 6. Remove the main P.C.B. in the direction of the arrow.</p>
<p><b>Procedure 9 → 10</b></p>	<p>1. Remove the 1 screw ( ❶ ). 2. Remove the holder. 3. Remove the sheet cover.</p> 	
<p><b>Ref. No. 11</b></p>	<p><b>Removal of the operation button (main) and operation button (sub)</b></p>	<p><b>Ref. No. 12</b></p> <p><b>Removal of the switch P.C.B.</b></p>
<p><b>Procedure 9 → 10 → 11</b></p>	<p>• Remove the 4 screws ( ❶ ~ ❹ ).</p> 	<p><b>Procedure 9 → 10 → 11 → 12</b></p> <p>1. Remove the holder. 2. Pull out the switch P.C.B. in the direction of the arrow.</p> 
<p><b>Ref. No. 13</b></p>	<p><b>Removal of the loading chassis (1)</b></p>	<p><b>Ref. No. 14</b></p> <p><b>Removal of the loading motor (1) P.C.B. and loading motor (1)</b></p>
<p><b>Procedure 1 → 2 → 3 → 13</b></p>  <p>1. Remove the spring. 2. Remove the 1 connector (CN453). 3. Remove the 2 screws ( ❶ , ❷ ).</p>	<p><b>Procedure 13 → 14</b></p> <p>1. Remove the 2 screws ( ❶ , ❷ ). 2. Unsolder the 2 terminals of loading motor (1). 3. Remove the drive belt (1). 4. Remove the 2 screws ( ❸ , ❹ ).</p> 	

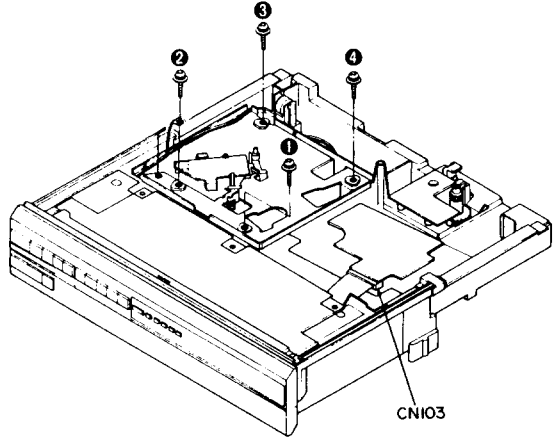
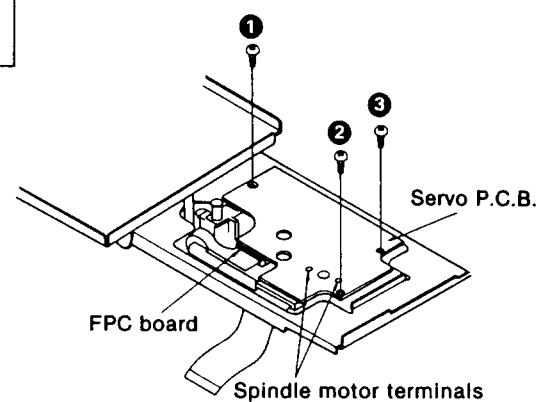
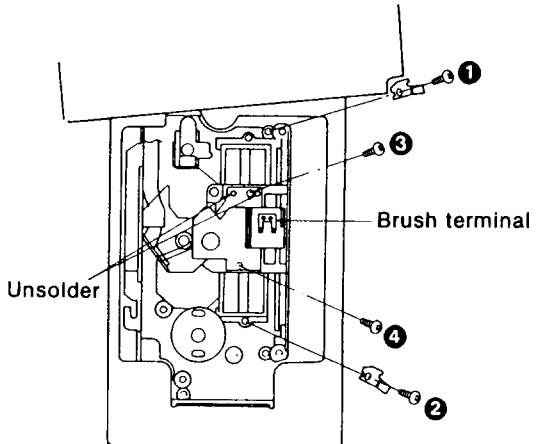
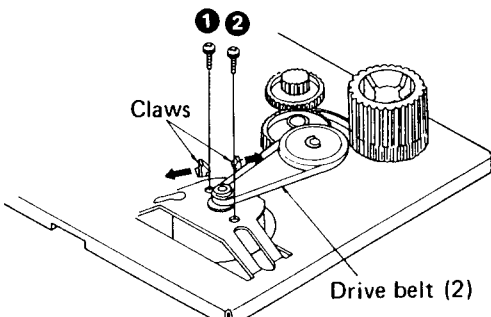
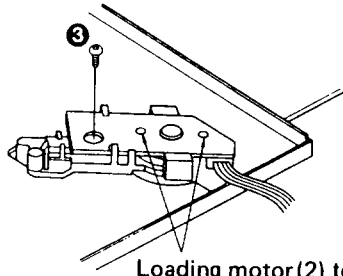

<p>Ref. No. 15</p>	<p><b>Removal of the loading chassis (2)</b></p>	<p>Ref. No. 16</p>	<p><b>Removal of the servo P.C.B.</b></p>
<p>Procedure 4→8→15</p>	<p>1. Remove the 4 screws ( ① ~ ④ ). 2. Remove the 1 flat cable (CN103). 3. Remove the 1 connector (CN451).</p> 	<p>Procedure 15 →16</p>	 <p>1. Remove the 3 screws ( ① ~ ③ ). 2. Unsolder the 2 terminals of spindle motor. 3. Remove the FPC board from the optical pickup. <b>Caution:</b> To prevent the breakdown of the laser diode, antistatic shorting pin is inserted into the FPC board.</p>
<p>Ref. No. 17</p>	<p><b>Removal of the optical pickup</b></p>	<p>Ref. No. 18</p>	<p><b>Removal of the loading motor (2)</b></p>
<p>Procedure 15→16→17</p>	<p><b>Refer to the handling precautions for optical pickup and instructions for traverse oil (See page 5).</b></p> <p>1. Remove the 2 screws ( ①, ② ). 2. Unsolder the 2 terminals and remove the 2 screws ( ③, ④ ).</p>  <p><b>Caution:</b> Take care not to touch the brush terminal.</p>	<p>Procedure 15 →18</p>	<p>1. Remove the drive belt (2). 2. Remove the 3 screws ( ① ~ ③ ). 3. Release the 2 claws. 4. Unsolder the 2 terminals of the loading motor (2).</p>  

**Ref. No. 19**      **Removal of the spindle motor**

**Procedure**  
15→16→19

1. Loosen the screw (1) by using a 1.27 mm allen wrench and remove the turntable.
2. Remove the 2 screws (2, 3).

**Caution:**

1. Turntable height adjustment is necessary any time the turntable or spindle motor is replaced.
2. The (+) terminal of the spindle motor is indicated by the red mark.

**Adjustment of turntable height**

1. Insert a 0.9mm clearance gauge between the turntable and loading base as shown in the figure.
2. Tighten the turntable set-screw by using a 1.27 mm allen wrench.

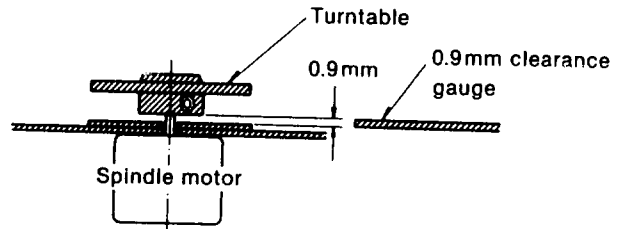
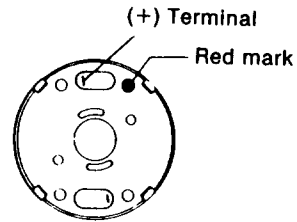
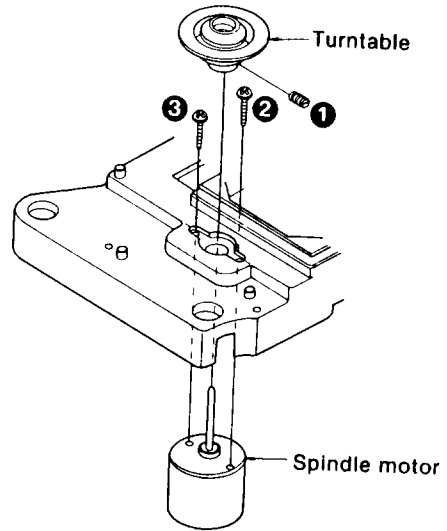

**Ref. No. 20**      **How to check the main P.C.B.**

**Procedure**  
1→2→3→4→5  
→6→8→9

- When checking the foil side of the main P.C.B. and replacing the parts, do as shown here.

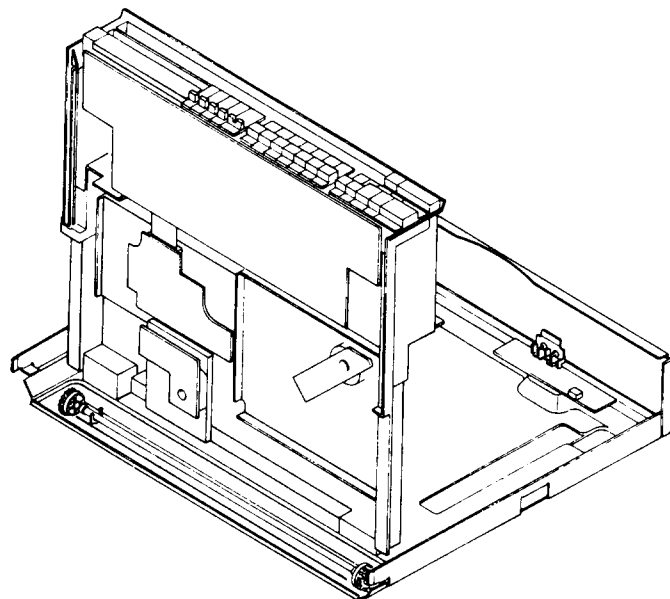

Pin No.	Symbol	Description
21	AVDD1	Power supply terminal 1 for analog system. (+5V)
22	OUTL2(-)	PWM output terminal for L 2 ch negative phase.
23	OUTL2(+)	PWM output terminal for L 2 ch positive phase.
24	OUTL1(-)	PWM output terminal for L 1 ch negative phase.
25	OUTL1(+)	PWM output terminal for L 1 ch positive phase.
26	AVSS1	Ground terminal 1 for analog system.
27	NC	
28	AVSS2	Ground terminal 2 for analog system.
29	OUTR1(+)	PWM output terminal for R 1 ch positive phase.
30	OUTR1(-)	PWM output terminal for R 1 ch negative phase.
31	OUTR2(+)	PWM output terminal for R 2 ch positive phase.
32	OUTR2(-)	PWM output terminal for R 2 ch negative phase.
33	AVDD2	Power supply terminal 2 for analog system. (+5V)
34	DVDD1	Power supply terminal 1 for digital system. (+5V) (Power supply for oscillation circuit)
35	DVSS1	Ground terminal 1 for digital system. (Ground for oscillation circuit)
36	X2	Crystal oscillation terminal.
37	X1	Crystal oscillation terminal.(External clock input terminal)
38	DVSS2	Ground terminal 2 for digital system.
39	NSUB	Connect to D-VDD.(Potential fixing terminal for Silicon circuit board)
40	DVDD2	Power supply terminal 2 for digital system. (+5V)
41	NC	
42	ZFLGB	Output terminal for zero output detector.

## INTERNAL CONNECTION OF FL

### • Grid connection diagram

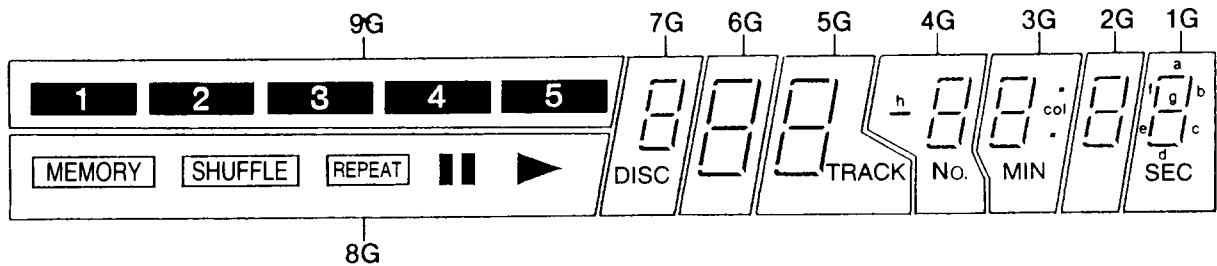

### • Anode connection table

	9G	8G	7G	6G	5G	4G	3G	2G	1G
a	-	-	a	a	a	a	a	a	a
b	5	MEMORY	b	b	b	b	b	b	b
c	4	SHUFFLE	c	c	c	c	c	c	c
d	3	-	d	d	d	d	d	d	d
e	2	-	e	e	e	e	e	e	e
f	1	▶	f	f	f	f	f	f	f
g	-	REPEAT	g	g	g	g	g	g	g
h	-		DISC	-	TRACK	-	MIN , col	-	SEC
i	-	-	-	-	-	No.	-	-	-

### • Pin connection

PIN NO.	1	2	3	4	5	6	7	8	9	10	11	12	13	14	15	16	17	18	19	20	21	22	23	24	25	26	27
CONNECTION	F <sub>1</sub>	F <sub>1</sub>	N <sub>P</sub>	N <sub>P</sub>	N <sub>P</sub>	N <sub>P</sub>	N <sub>P</sub>	N <sub>P</sub>	N <sub>P</sub>	N <sub>P</sub>	N <sub>P</sub>	N <sub>P</sub>	N <sub>P</sub>	N <sub>P</sub>	N <sub>P</sub>	N <sub>P</sub>	N <sub>P</sub>	N <sub>P</sub>	N <sub>P</sub>	N <sub>P</sub>	8G	7G	6G	5G	4G	3G	2G
PIN NO.	28	29	30	31	32	33	34	35	36	37	38	39	40	41	42												
CONNECTION	1G	9G	i	h	g	f	e	d	c	b	a	N <sub>P</sub>	N <sub>P</sub>	F <sub>2</sub>	F <sub>2</sub>												

# TROUBLESHOOTING GUIDE

## PLAYBACK FLOW CHART

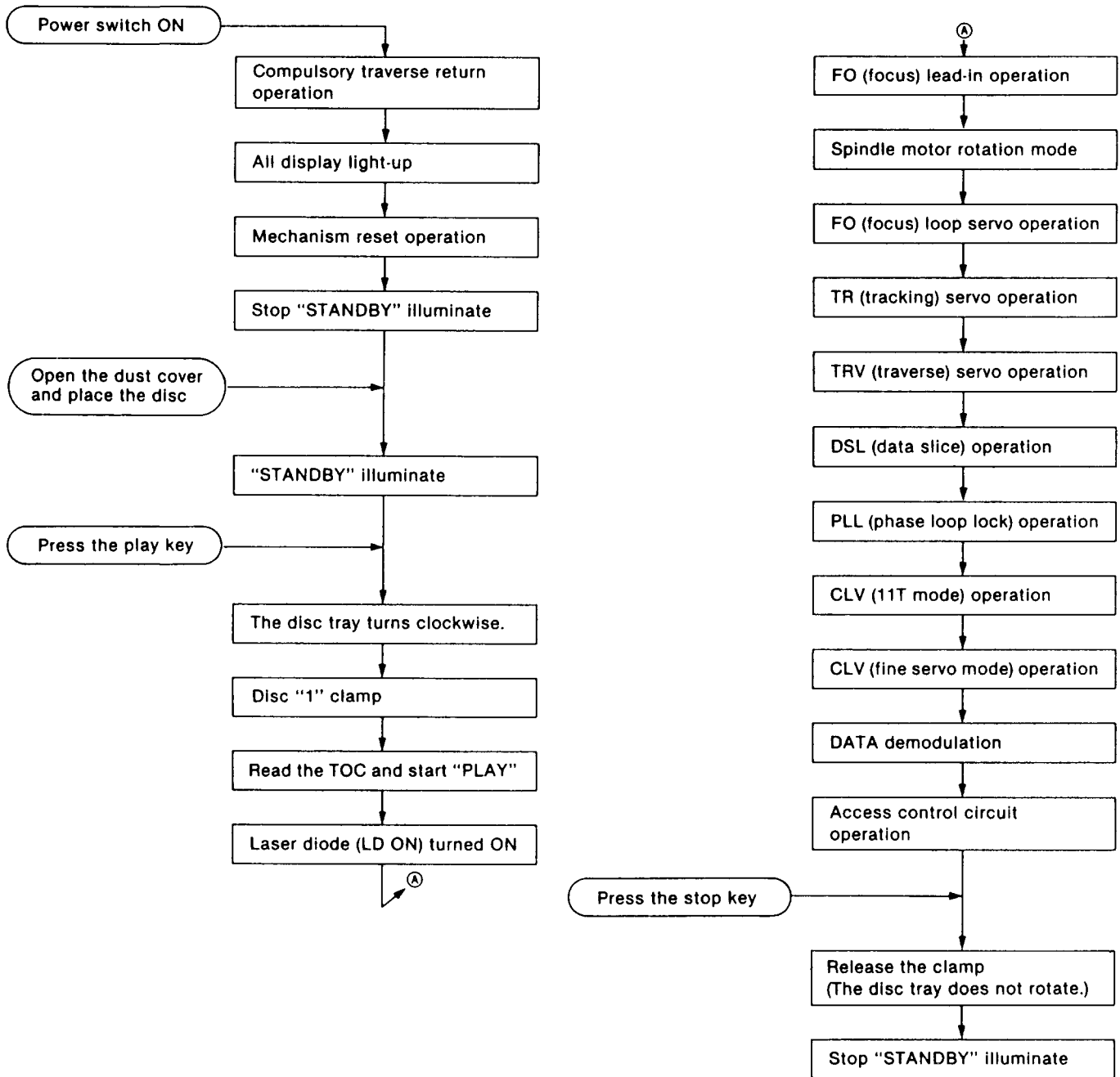

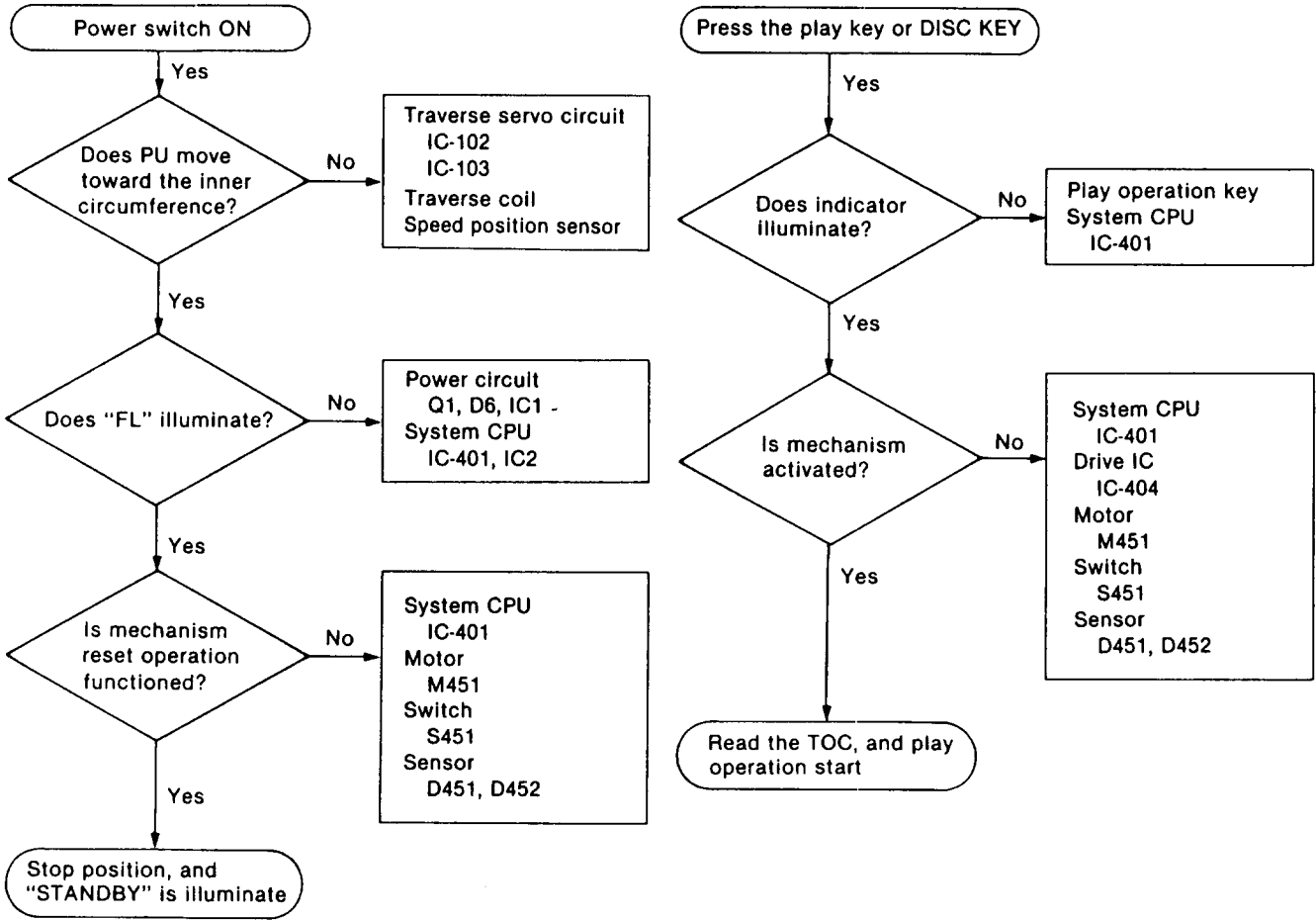

**TOC READ OPERATION - PLAY OPERATION**

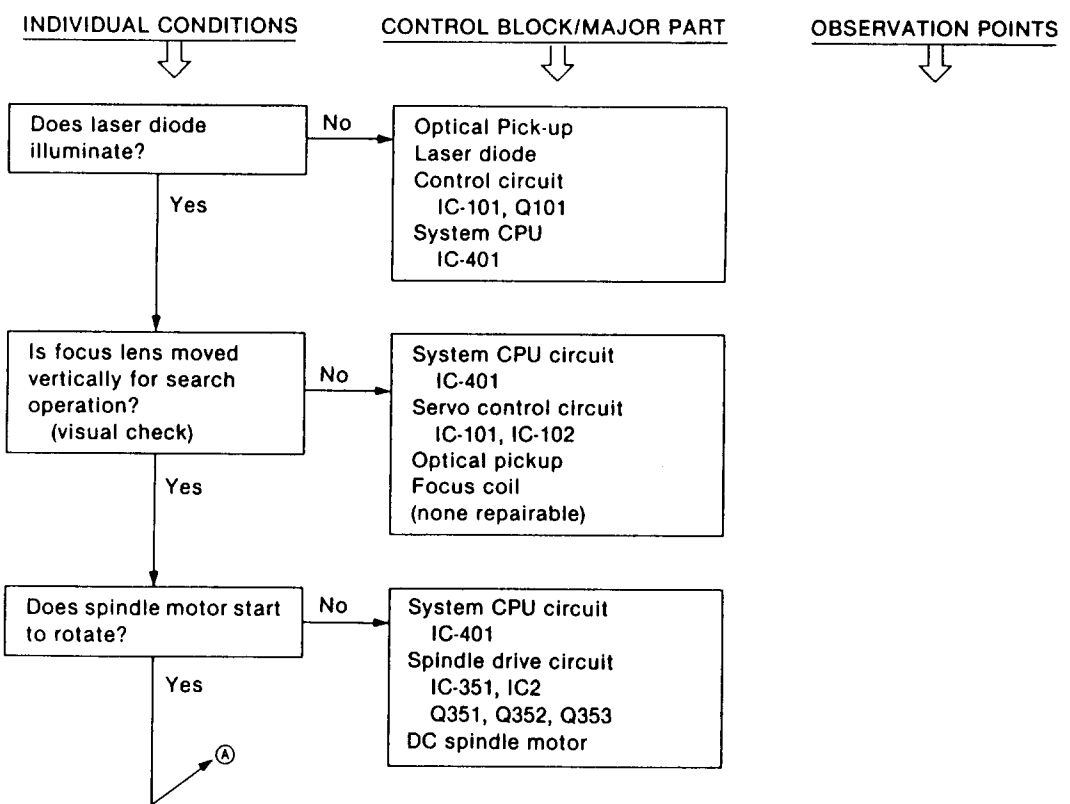

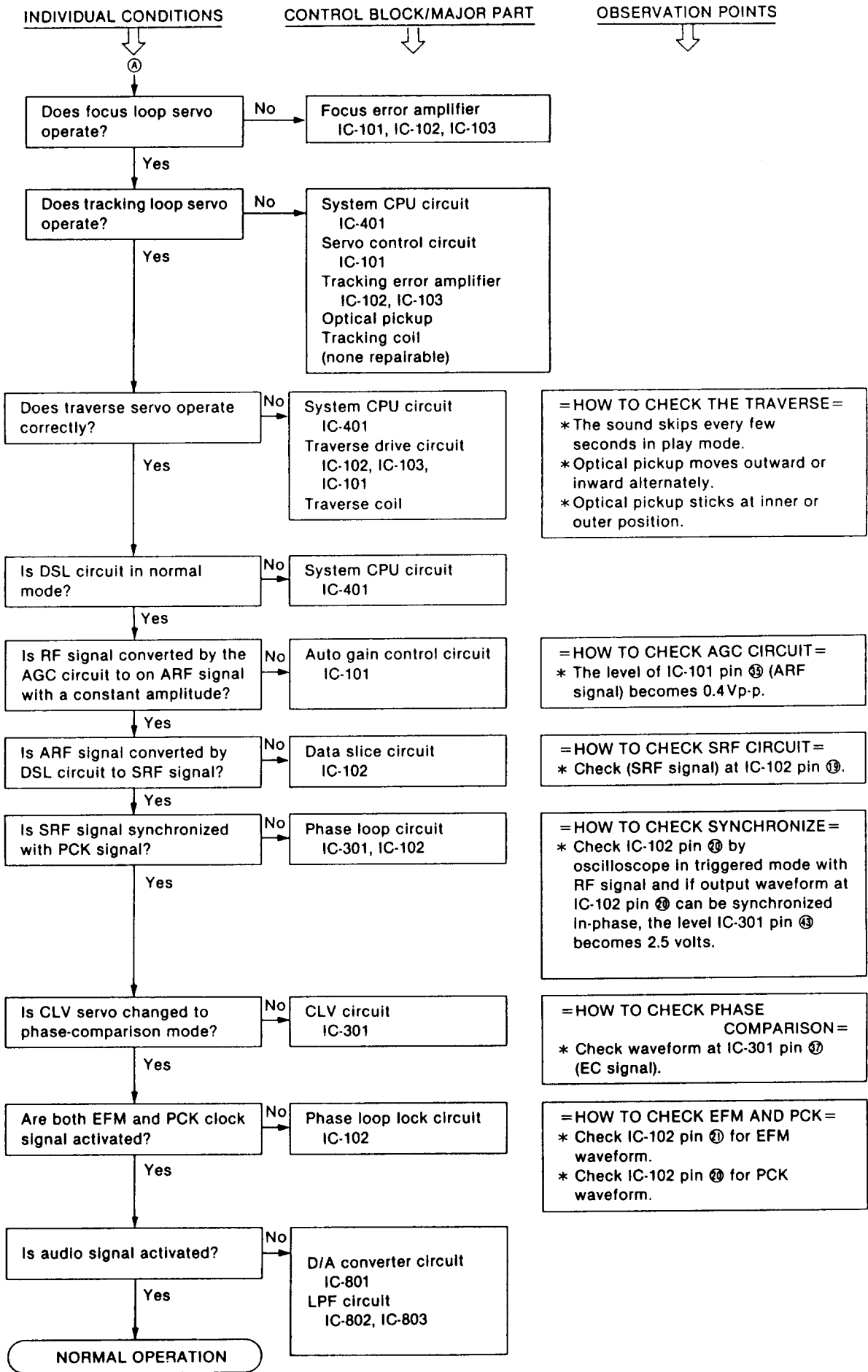

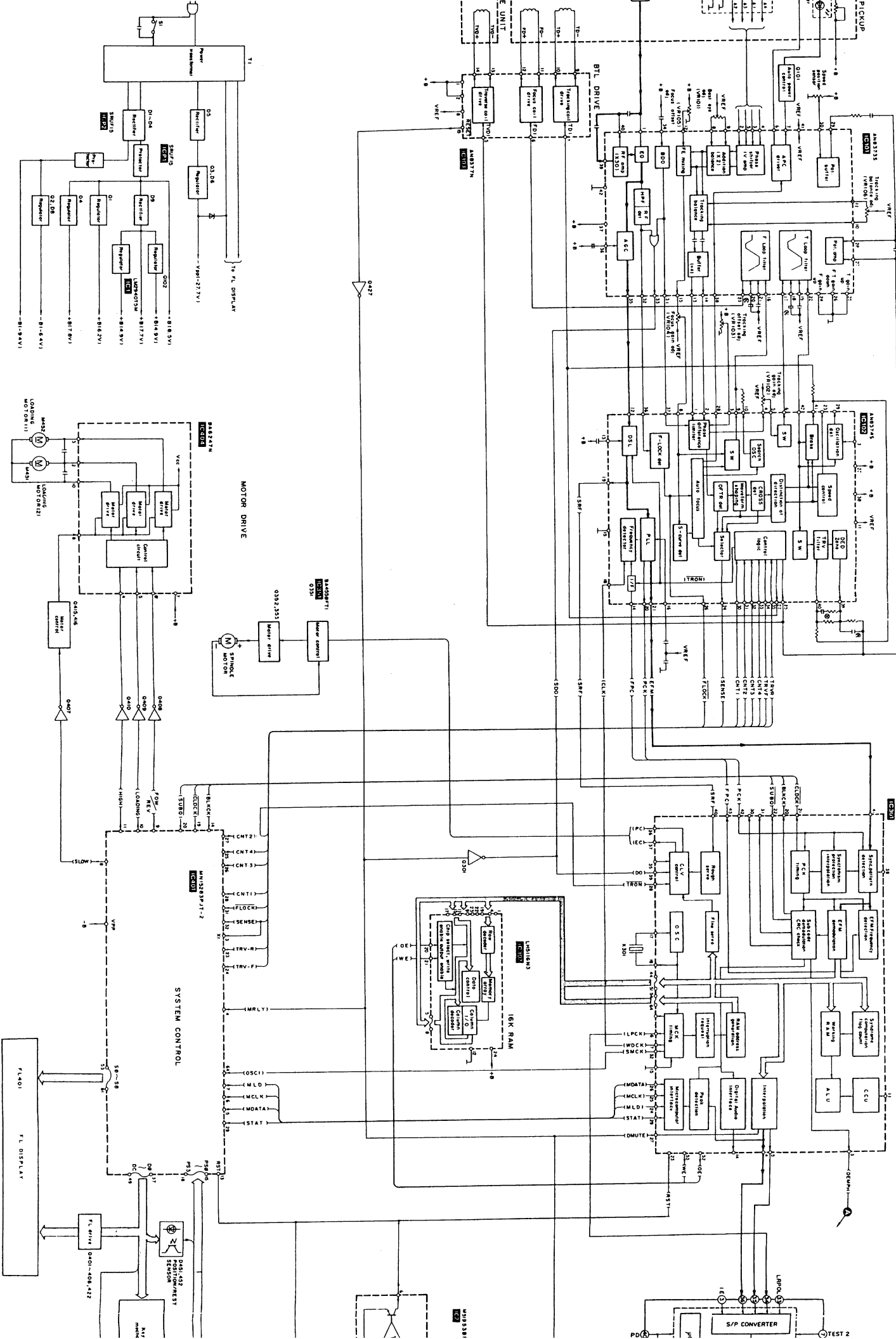





# PRINTED CIRCUIT BOARD—PARTS LIST

## MAIN PC BOARD – PARTS LIST

CIRCUIT NO.	PART NO.	DESCRIPTION
	ICs	
IC1	22240346	LM2940T5M
IC2	22240347	M51953BFP
IC301	22240348	MN6625
IC302	22240471	LH5116N3
IC351,IC803	22240350	BA4558F
IC401	22240351	MN15283PJT-2
IC403	22240352	MN15522PKE
IC404	22240353	BA6247N
IC801	22240389	MN6474
IC802	22240472	LM833M63
	IC protectors	
ICP1,ICP2	252122	△ SRUF15
	Transistors	
Q1,Q352	2213783 or 2213784	2SD1862-Q or 2SD1862-R
Q2,Q353	2213793 or 2231794	2SB1240-Q or 2SB1240-R
Q3	2213803, 2213804 or 2213805	2SB1238-Q, 2SB1238-R or 2SB1238-S
Q301,Q853	226037 or	UN4212 or
Q401-Q406	2213160	DTC124ES
Q351	226036 or	UN4112 or
Q407-Q410	2212600	DTA124ES
Q411-Q413	2201903	2SA1309-Q
Q415,Q416	226037 or	UN4212 or
Q422	2213160	DTC124ES
Q417,Q419	2201903	2SA1309-Q
Q420,Q423	2201903	2SA1309-Q
Q427	226036 or	UN4112 or
Q851,Q852	2212600	DTA124ES
Q801,Q802	2201893	2SC3311-Q
Q803,Q804	2213814, 2213815 or 2213816	2SD1450-R, 2SD1450-S or 2SD1450-T
Q854	2213510	DTA114ES
	FL tube	
FL401	212085	RSL0047-F
	Diodes	
D1-D5	223192	△ 1SR35200TB
D6	224452702	MTZ27B
D7,D8	224450682	MTZ6.8B
D9	223192	△ 1SR35200TB
D10	224450622	MTZ6.2B
D12	223193	MA723
D351,D352	224450512	MTZ5.1B
D401-D408	223163	1SS133
D410-D416	223163	1SS133
D417	224450302	MTZ3.0B
D418	224450332	MTZ3.3B
D419-D425	223163	1SS133
D801-D803	223163	1SS133
D851-D854	223163	1SS133
	Coils	
L401,L403	231177	RLQZP3P3K
L451	231177	RLQZP3P3K
L454-L457	231177	RLQZP3P3K
L460,L461	231177	RLQZP3P3K
	X'tal	
X301	3010173	33.8688MHZ
	Ferrite beads	
Z301,Z303	230909	EXCELDR35V
Z803	230909	EXCELDR35V
	Capacitors	
C4	354743329	3300 $\mu$ F,16V,Elect.
C5	354742229	2200 $\mu$ F,16V,Elect.
C6	354774709	47 $\mu$ F,63V,Elect.
C10,C11	354734719	470 $\mu$ F,10V,Elect.
C12,C13	354731019	100 $\mu$ F,10V,Elect.
C15	354722219	220 $\mu$ F,6.3V,Elect.

CIRCUIT NO.	PART NO.	DESCRIPTION
C19	354781099	0.1 $\mu$ F,50V,Elect.
C301,C306	354721019	100 $\mu$ F,6.3V,Elect.
C305	354723319	330 $\mu$ F,6.3V,Elect.
C402	354724709	47 $\mu$ F,6.3V,Elect.
C407	354721019	100 $\mu$ F,6.3V,Elect.
C809,C810	374723334	0.033 $\mu$ F $\pm$ 5%,50V,Plastic
C811,C812	371121024	1000pF $\pm$ 5%,50V,Mylar
C815,C816	354784709	47 $\mu$ F,50V,Elect.
C823,C824	354723319	330 $\mu$ F,6.3V,Elect.
C827,C828	354734709	47 $\mu$ F,10V,Elect.
C851	354741009	10 $\mu$ F,16V,Elect.
C852	354721029	1000 $\mu$ F,6.3V,Elect.
	Filters	
Z451-Z453	3030003	DSS30654E222
Z801,Z802	3030005	DSS36431B102
	Resistor	
R424	441620394	3.9 $\Omega$ ,1W,Metal oxide film
	Switches	
SW41	25035621	RMN0010
SW42	25035622	RMN0011
	Plugs	
CN301	25055597	SJSD2221
CN403,CN452	25055598	RJS4T4ZA
CN453	25055599	RJP5G182ZA
	Sockets	
BT1	2009990086	REX0076-2
BT801	2009990178	REX0160-2
	Bracket	
	27141402	RMN0014-1

## SWITCH PC BOARD – PARTS LIST

CIRCUIT NO.	PART NO.	DESCRIPTION
S418,S419	25035623	EVQQTG05R,Switches

## REMOTE SENSOR PC BOARD – PARTS LIST

(Only model DX-C201)

CIRCUIT NO.	PART NO.	DESCRIPTION
IC602	24130005	RCD0004,Remote control sensor

## LINE OUT PC BOARD – PARTS LIST

CIRCUIT NO.	PART NO.	DESCRIPTION
D427	224450562	MTZ5.6B,Diode
RK401	25045294	RJJ33T01,Jack
JK801	25045295	RJH3201N,Jack
CN801	25055486	SJTD414W,Plug

## LOADING MOTOR (1) PC BOARD – PARTS LIST

CIRCUIT NO.	PART NO.	DESCRIPTION
S453,S454	25065392	SSPD12,Microswitch
CN453	25055488	SJTD514W,Plug

## LOADING MOTOR (2) PC BOARD – PARTS LIST

CIRCUIT NO.	PART NO.	DESCRIPTION
S451	25065392	SSPD12,Microswitch
CN451	25055489	RJS4T7ZA,Plug

## SENSOR PC BOARD – PARTS LIST

CIRCUIT NO.	PART NO.	DESCRIPTION
D451,D452	24120029	SVDGPI5S3,Interruptors

## POWER SUPPLY PC BOARD – PARTS LIST

CIRCUIT NO.	PART NO.	DESCRIPTION
C1001	3500065A	△ DE7150FZ103PAC400/125V, Capacitor IS
JK1	25050412	△ SJS9237,AC inlet
CN1	25055487	SJTD614,Plug
S1	25035624	△ ESB8249V,Push switch

NOTE: THE COMPONENTS IDENTIFIED BY MARK △ ARE CRITICAL FOR RISK OF FIRE AND ELECTRIC SHOCK. REPLACE ONLY WITH PARTS NUMBER SPECIFIED.

# SCHEMATIC DIAGRAM

(This schematic diagram may be modified at any time with development of new technology.)

**Notes:**

- S1 : Power switch in "on" position.
- S401~405 : Disc select (disc. 1~5) switches.  
[S401: 1, S402: 2, S403: 3, S404: 4, S405: 5]
- S406 : Time mode select (time mode) switch.
- S407, 408 : Skip (▶) skip (▶▶) switches.  
S407: ▶▶ S408: ▶▶▶
- S409, 410 : Search (◀◀ search ◀◀◀) switches.  
S409: ◀◀ S410: ◀◀◀
- S411 : Program/continue (program/continue) switch.
- S412 : Repeat (repeat) switch.
- S413 : Pause (|| pause) switch.
- S414 : Play (▶ play) switch.
- S415 : Shuttle (random) switch.
- S416 : Stop (■ stop) switch.
- S418 : Disc skip (disc skip) switch.
- S419 : Open/close switch (Disc).
- S451 : Clamp switch.
- S453 : Open switch (Loading).
- S454 : Close switch (Loading).

• The voltage value and waveforms are the reference voltage of this unit measured by DC electronic voltmeter (high impedance) and oscilloscope on the basis of chassis.  
Accordingly, there may arise some error in voltage values and waveforms depending upon the internal impedance of the tester or the measuring unit.

\* The parenthesized are the values of voltage generated during playing (Test disc 1kHz, L+R, 0dB), others are voltage values in stop mode.

- Important safety notices:  
Components identified by Δ mark have special characteristics important for safety. When replacing any of these components, use only manufacturer's specified parts.
- ◀◀ / ▶▶ : Positive voltage lines and negative voltage lines.
- ○○○○○○ : audio signal lines.

**Caution!**  
IC and LSI are sensitive to static electricity. Secondary trouble can be prevented by taking care during repair.  
• Cover the parts boxes made of plastics with aluminum foil.  
• Ground the parts soldering iron.  
• Put a conductive mat on the work table.  
• Do not touch the pins of IC or LSI with fingers directly.

**SERVO CIRCUIT PC BOARD - PARTS LIST**

CIRCUIT NO.	PART NO.	DESCRIPTION
IC101	22240476	AN8373S
IC102	22240477	AN8374S
IC103	22240478	AN8377N

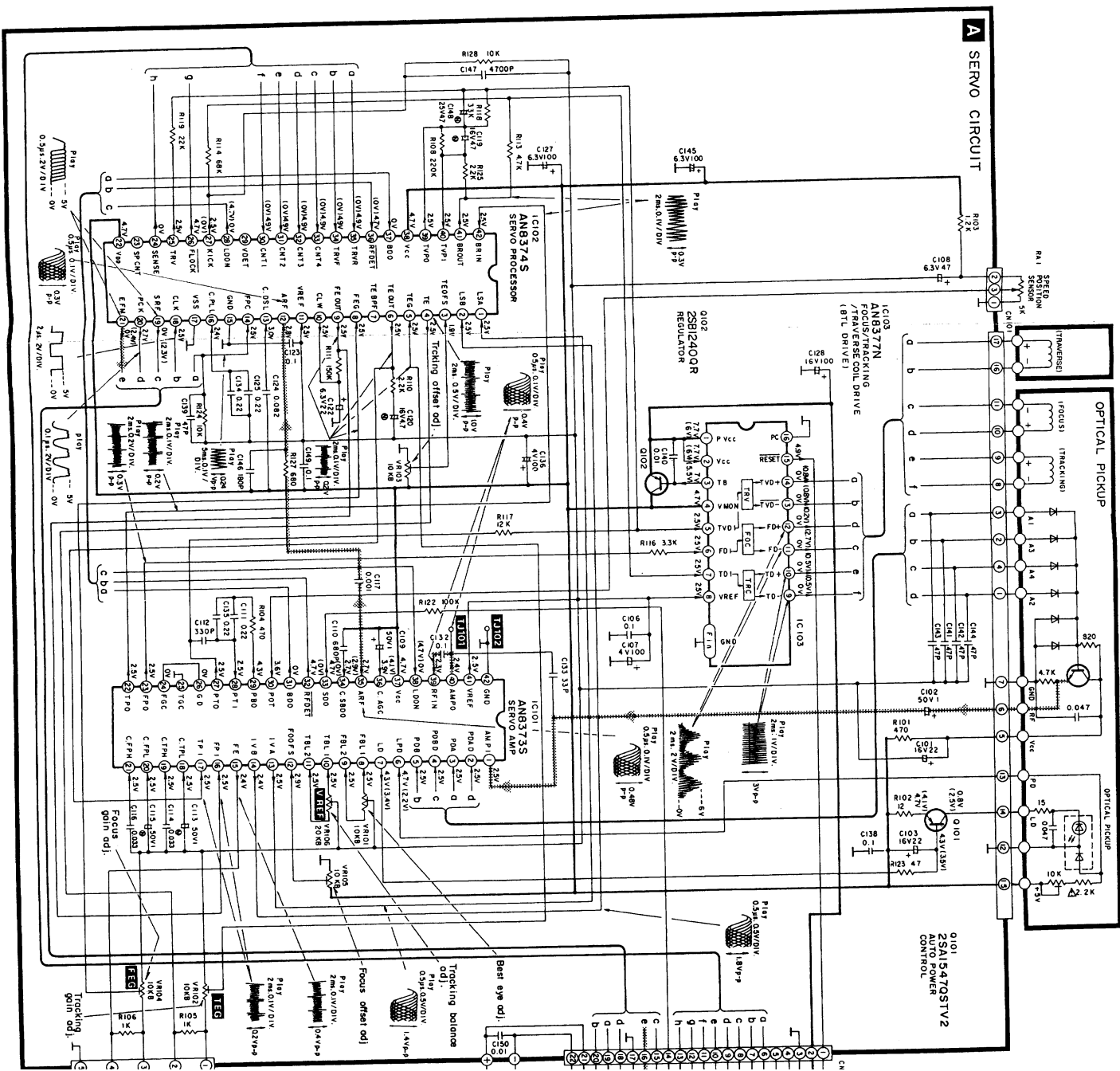

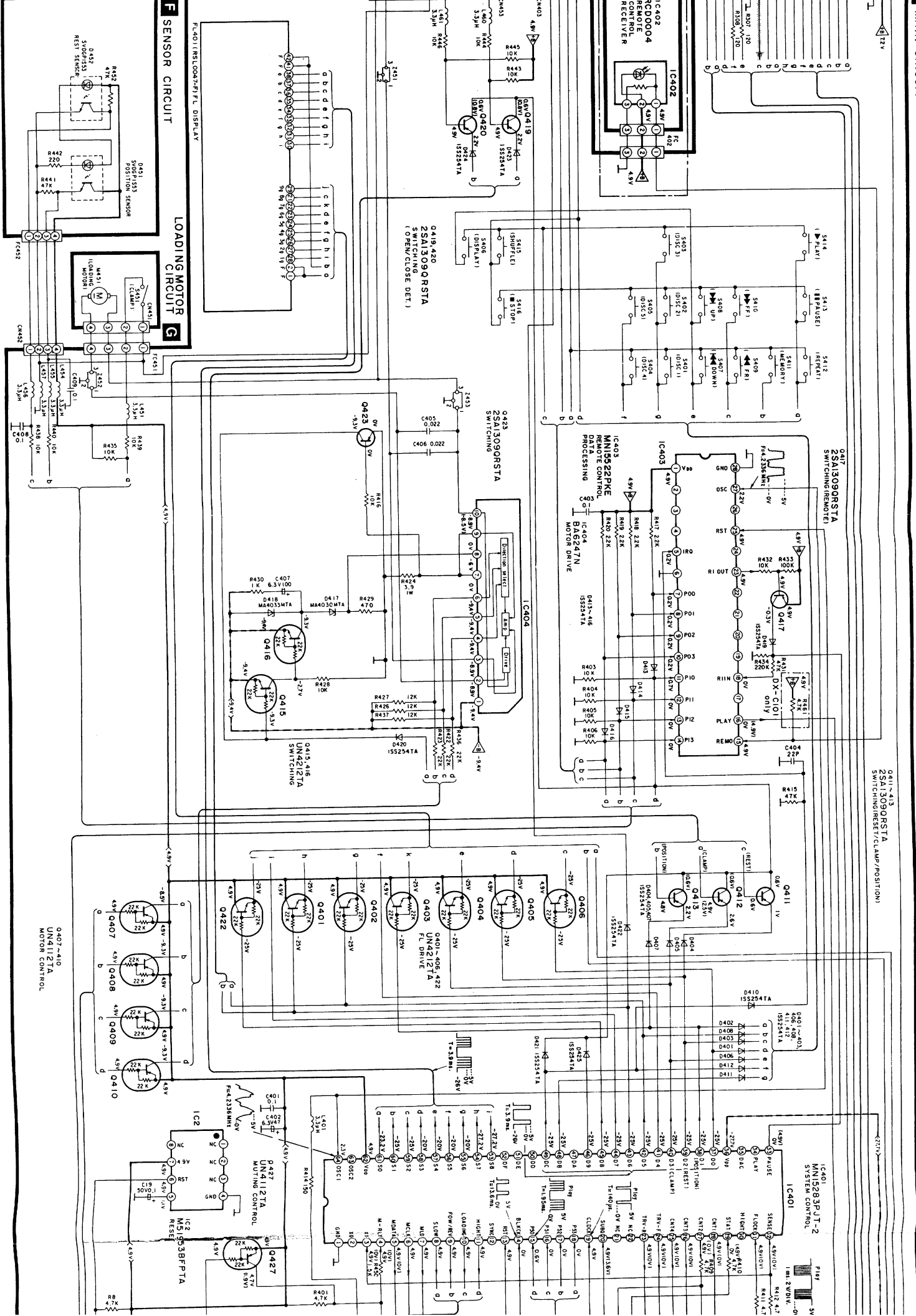

F SENSOR CIRCUIT

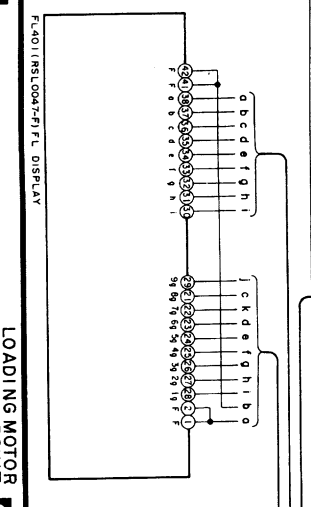

G LOADING MOTOR CIRCUIT

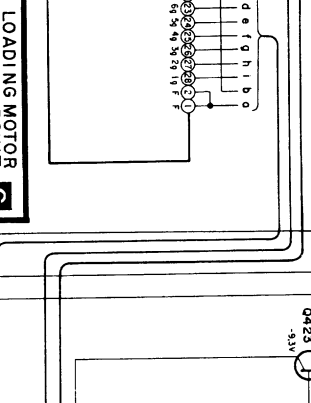

Q411-Q413 SWITCHING/RESET/CLAMP/POSITION

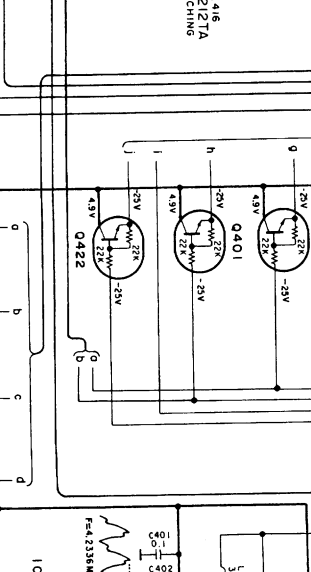

Q423 SWITCHING

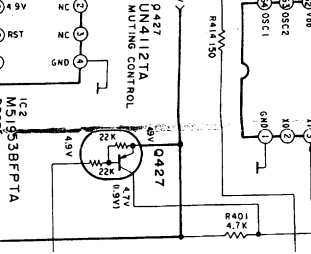

Q419, 420 SWITCHING (OPEN/CLOSE DEF.)

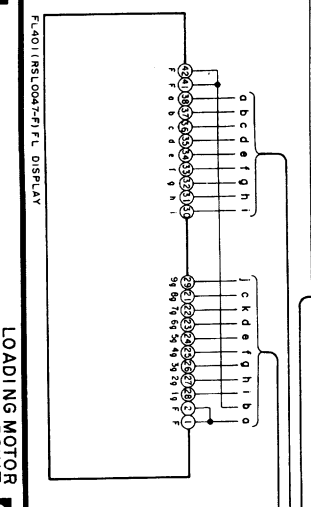

Q415, 416 SWITCHING

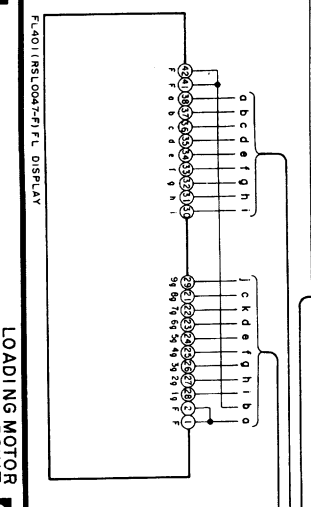

Q417 DATA CONTROL

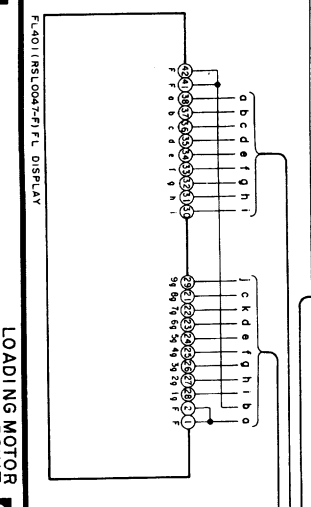

Q418, 416 DATA PROCESSING

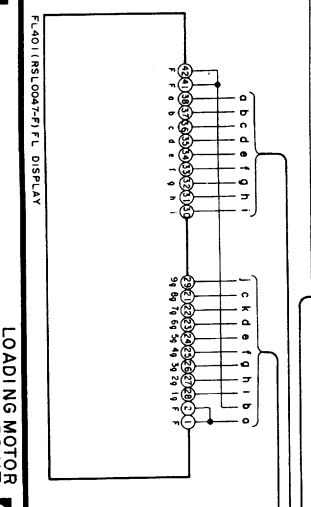

Q419, 418 MOTOR DRIVE

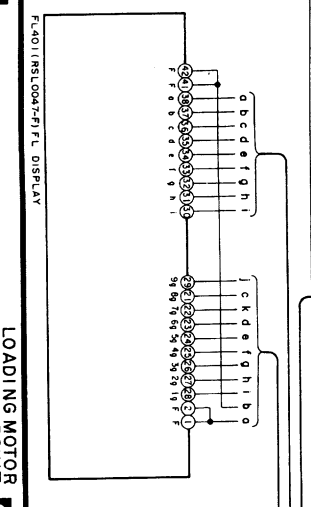

Q407-410 MOTOR CONTROL

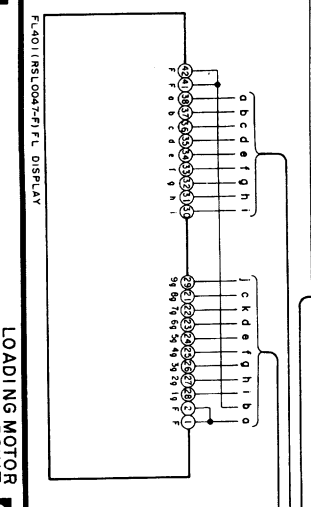

Q427 MUTING CONTROL

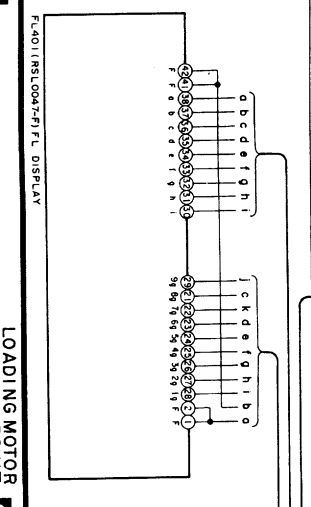

Q427 Muting Control

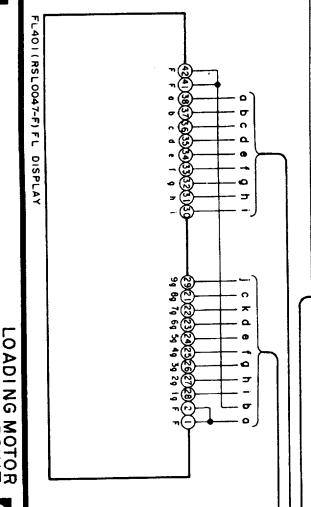

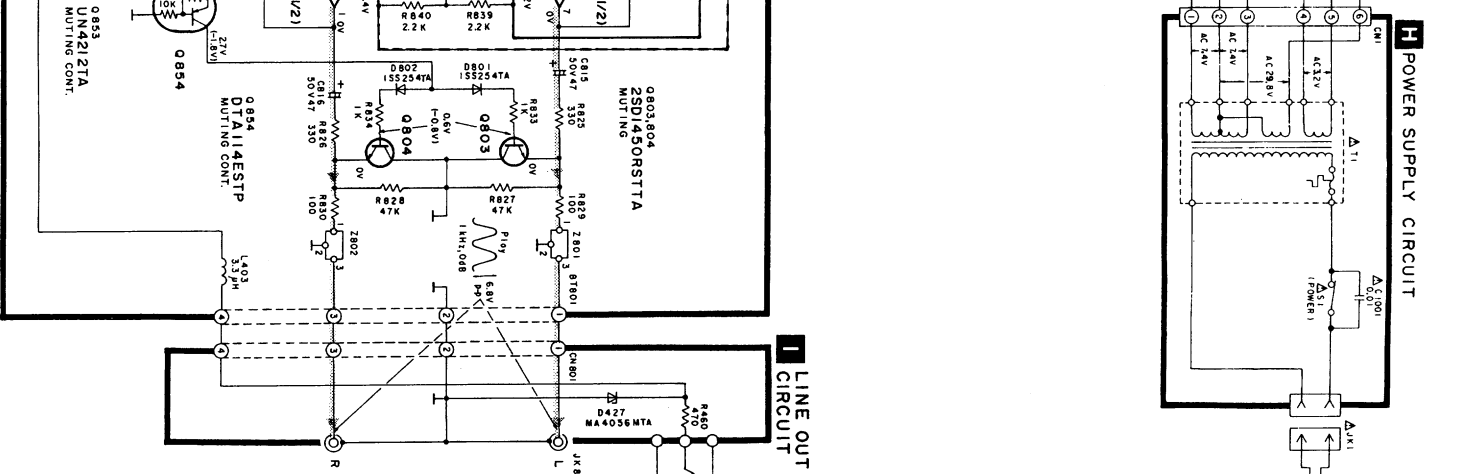
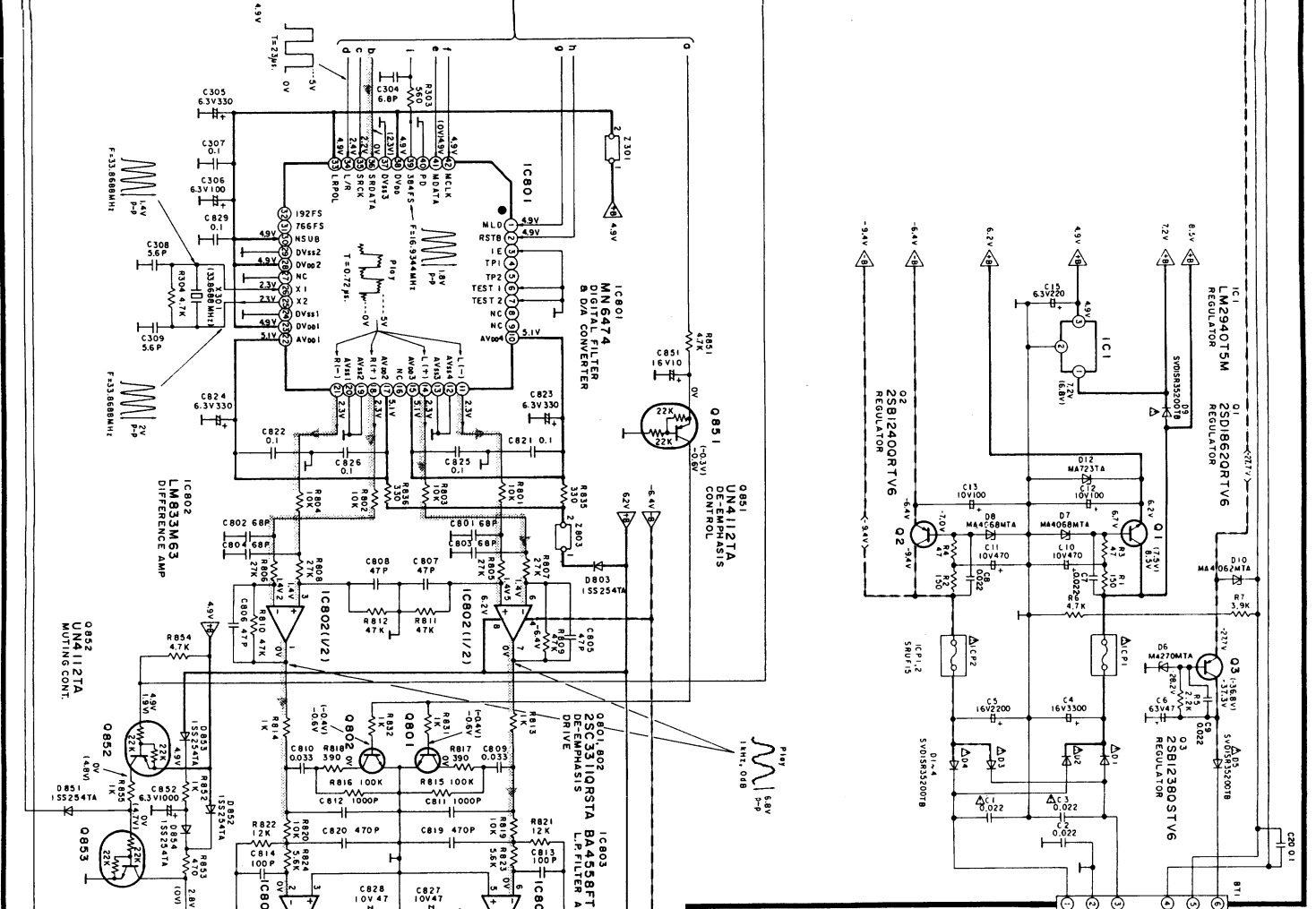
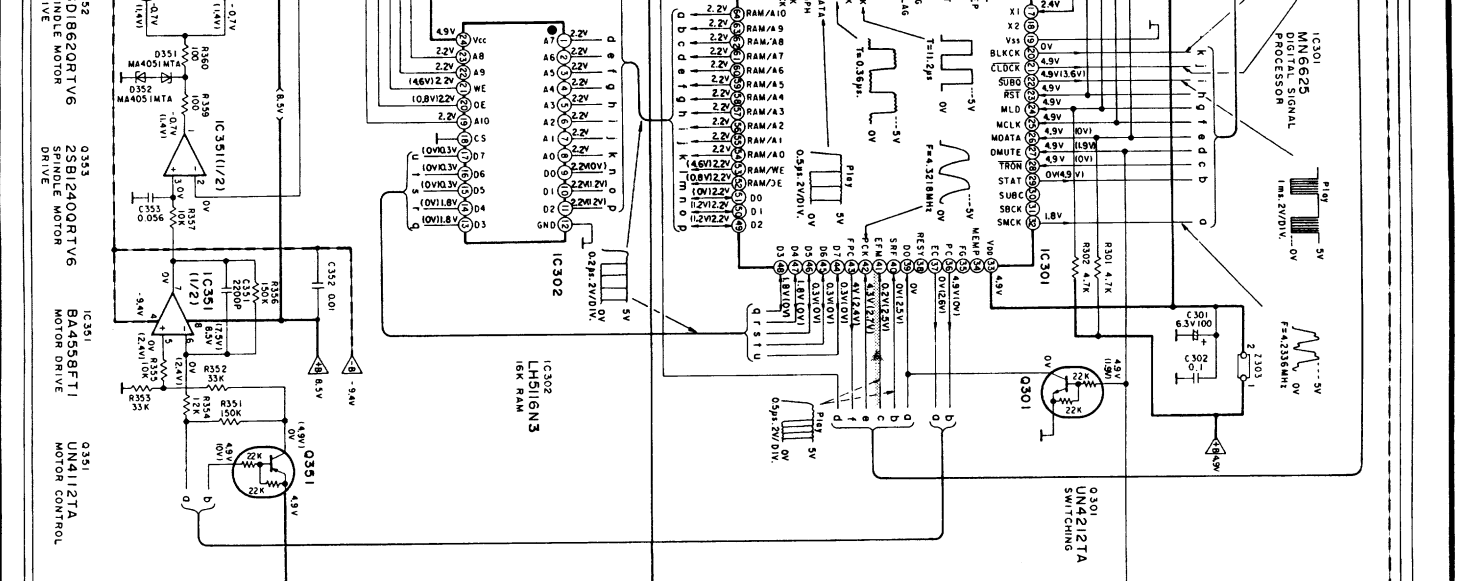

# PACKING VIEW

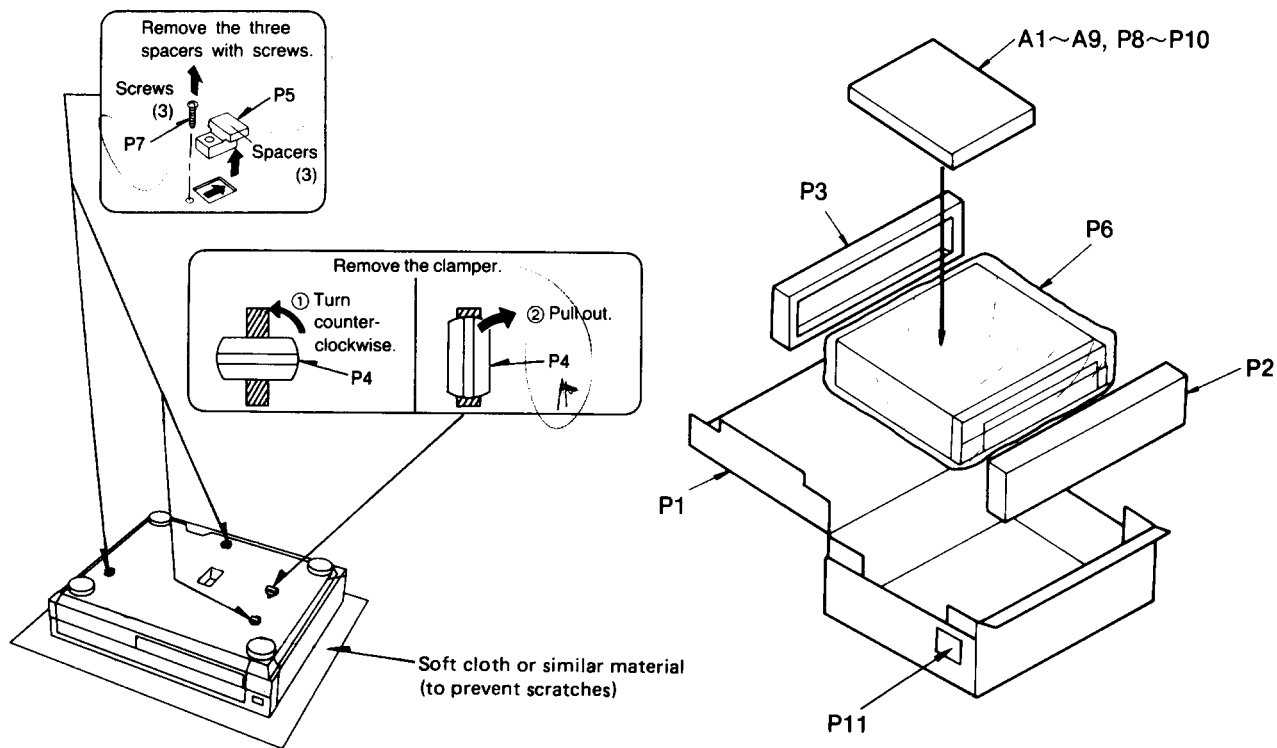

REF.NO.	PART NO.	DESCRIPTION
P1	29052201	Master carton box <DX-C101>
	29052202	Master carton box <DX-C201>
P2	29091493	Pad A
P3	29091494	Pad B
P4	28400587	Clamper
P5	28400588	Clamper
P6	29100113	Protection sheet
P7	801445	Transport screw
P8	29100114	Protection bag (Accessory)
P9	29105161	Accessory box
P10	29100115	Styrene bag
A1	29341600	Instruction manual
	29341601	Instruction manual <Canadian model>
A2	29365019A	Warranty card
A3	29358002J	Service station list
A4	2010211	⚠ SJA172-1, Power supply cord
A5	2010098A	Output cord
A6	2010200	Remote control cord
A7	28400589	Spacer B for mechanism
A8	24140201	RC-201C, Remote control transmitter <DX-C201>
A9	3010054	UM-3, Two batteries <DX-C201>
	29355163	Caution label (on the top cover)
	29355174	Caution label

# EXPLODED VIEWS

## • Traverse deck parts

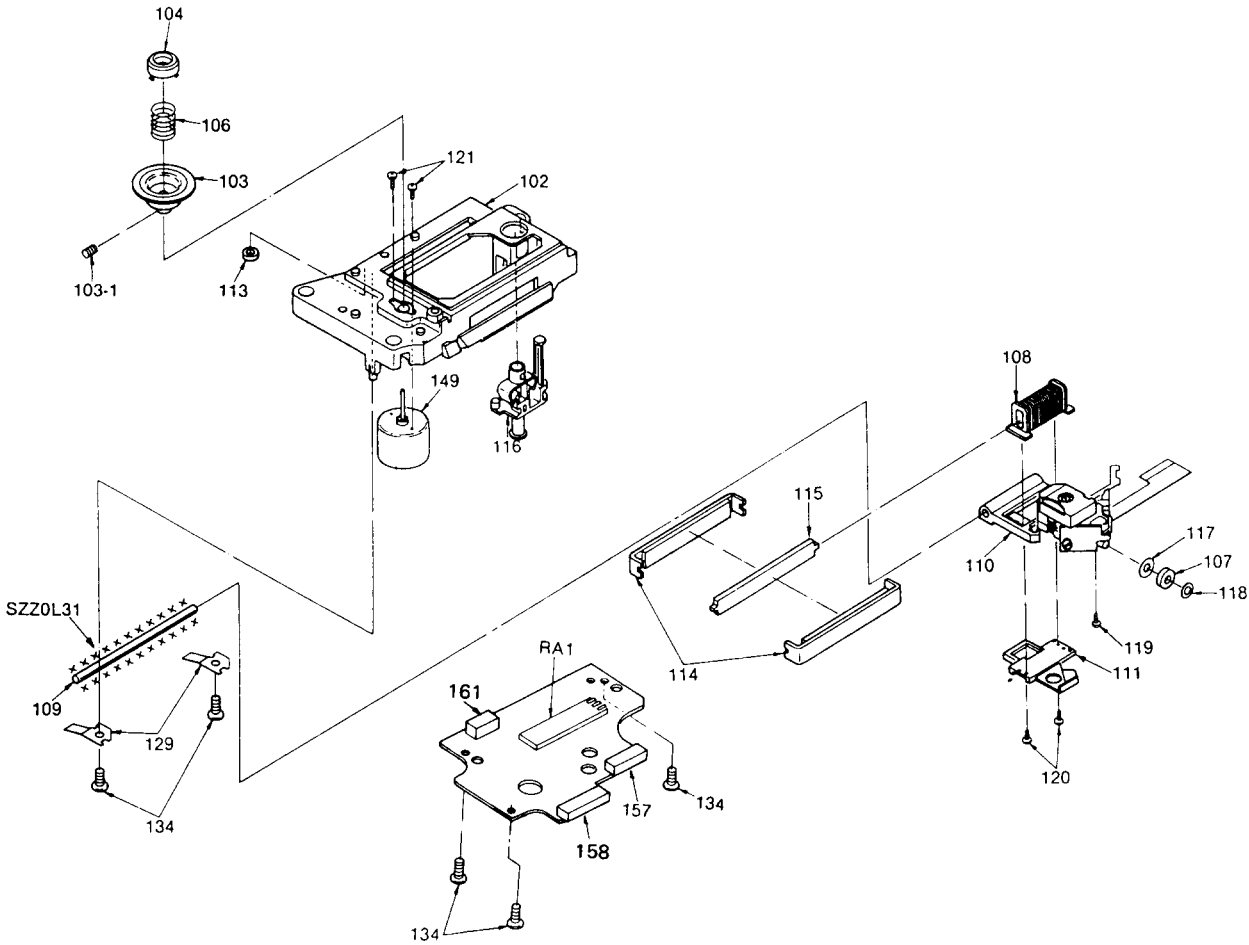

REF.NO.	PART NO.	DESCRIPTION
	24506933A	Traverse deck ass'y
102	24506934-1	Traverse base
103	24506935-1	Turntable
103-1	801446	Special screw
104	24506936	Ring
106	24503182	Spring
107	24506937-1	Roller
108	24506976	Coil
109	24506939	Guide shaft
110	34506940	▲ Optical pickup
111	24506941-1	Coil holder
113	24506946	Stopper
114	24506978	Yoke
115	24506943-1	Yoke
116	24506977	Lock unit
117	27270318	Special washer
118	27270319	Special washer
119	801448	Special screw
120	833120050	2TTP+5P,Self tapping screw
121	801447	2SMP.SW+8F,Sems screw
129	24506945-1	Guide shaft holder
134	838130100	3TTB+10P,Self-tapping screw
149	24502258-1	Spindle motor



## PARTS LIST

REF.NO.	PART NO.	DESCRIPTION	REF.NO.	PART NO.	DESCRIPTION
1	28184492	Top cover	57	27260296	Guide shaft
2	27301305-1	Gear,timing	58	893030	E-3,E ring
3	2009990088	Connector ass'y	59	24503176	Spring
4	2050032	Flat cable	60	27270316-1	Spacer, traverse
5	27215210	Front panel A ass'y <DX-C101>	61	24506973	Floating rubber
	27215211	Front panel A ass'y <DX-C201>	62	24503186	Spring (A)
6	27211325	Front panel B ass'y	63	24503187	Spring (B)
7	27301306-1	Cover,clamp	64	24503188	Spring (C)
8	24506908	Tray,rotary	66	24506919-1	Roller shaft
9	28324382	Knob POWER	67	27100214	Chassis
10	28324028-1	Knob PLAY	68	24506920	Cushion,dust cover
11	28324029	Knob MEMO	70	24506921-1	Gear,pulley
12	28324030-1	Knob SKIP	71	24506922	Gear,main
13	27100244	Chassis ass'y	72	24506923	Gear,drive
- 13-1	27175248-1	Foot -	73	24504429	Elevator cam
13-2	27267676	Bracket	75	24503180-1	Spring
14	28110567	Loading cabinet ass'y	78	24506924	Mechanism chassis ass'y
15	27141399	Plate,main	80	24506925	Main arm ass'y
16	27141479	Plate,sub	80-1	24506926	Gear
17	27130613	Guide plate (L)	80-2	24503181-1	Spring
18	27130654	Guide plate (R)	80-3	27270317	Special washer
19	27130615	Operation frame plate	80-4	24506927	Main arm
20	27301307	Earth plate	81	24506928	Holder
21	27301308	Earth plate,panel	82	24506929	Switch lever
22	27301309	Spring,friction	83	27130616	Bracket,panel
23	27301310	Spring,lock lever	84	27301321	Earth spring
24	27301311	Spring,set lever	86	24506930	Plate,lead wire
25	27267737	Guide,lead wire	87	24506931	Guide,roller
26	27301312-1	Lock lever	88	893040	E-4,E ring
27	27273130	Rod,power switch	89	28324031	Knob, lock unit
28	27301313-1	Holder,gear shaft	90	27301322	Spacer,knob
29	27190770	Tray holder	91	27301323	Spring,slider
30	27301314	Cover,lead holder	92	27301324	Plate,rack
31	27301315	Cover,lock unit	93	27220040	Slider
32	27260295	Timing gear shaft	94	24506932	Base slider
33	28175173	Insulator plate	95	27100245	Sub chassis
34	27150296	Shield plate	N1	801440	Special screw
35	24506909	Clamp lid	N2	838430088	3TTB+8B(BC),Self-tapping screw
36	24506910-1	Clamper	N3	838130148	3TTB+14B,Self-tapping screw
37	28181025	Magnet	N4	801441	26SMP.SW+4F,Sems screw
38	24506911	Yoke	N5	838130168	3TTB+16B,Self-tapping screw
39	24502256	Motor ass'y	N7	831130088	3TTW+8B,Self-tapping screw
41	24506975	Switch lever	N8	801442	3SMP8W.SW+8F,Sems screw
42	24506914-1	Switch holder	N9	838430108	3TTB+10B(BC),Self-tapping screw
43	27100240	→Loading chassis ass'y	N10	838130060	3TTB+6P,Self-tapping screw
44	24506915	Pulley gear	N11	801443	Special screw
45	27270320	Washer (A)	N12	801444	Special screw
46	24506916	Belt	N14	838130080	3TTB+8P,Self-tapping screw
47	24506917	Set lever	T1	2300552	△ NPT-C100,Power transformer
48	27141401	Rack cover	A	24505280	Servo pc board ass'y
49	27301316	Spring, working	B	24505302	Main pc board ass'y
50	27301317	Rack plate	C	24505315	Sensor pc board ass'y <DX-C201>
51	27301318	Working rack,front	D	24505314	Switch pc board ass'y
52	27301319	Working rack,rear	E	24505276	Loading motor (1) pc board ass'y
53	27121441	Back panel <DX-C101>	F	24505316	Sensor pc board ass'y
	27121442	Back panel <DX-C201>	G	24505277	Loading motor (2) pc board ass'y
54	27190771	Pc board support	H	24505317	Power supply pc board ass'y
55	27301320	Cord clamper	I	24505303	Line out pc board ass'y
56	27301443	Cover, remote control <DX-C201>			



## ADJUSTMENT PROCEDURES

**Warning :** This product uses a laser diode. Refer to caution statements on page 4.

**Caution :** During adjustment, never connect CH-2 probe's GND to any place for it may short Vref line.  
(Connect CH-1 probe's GND to specified TP. described in each section.)

### PREPARATION

1. Remove the top cover (refer to disassembly instruction Ref. No. 1).
2. Remove the clamp chassis and clamp cover (refer to disassembly instruction Ref. No. 4).
3. (1) The carousel rotates clockwise and stops at the fifth tray.  
(2) Set the power switch to OFF and then to ON again, when the optical deck reaches it's height position, set the power switch to OFF.
4. Remove the disc tray (refer to disassembly instruction Ref. No. 8).
5. Place the test disc and secure it by using the magnet (refer to disassembly instruction Ref. No. 9).
6. Set the unit in the test mode as follows:  
(hold the **play** , **stop** and **disc 1** keys (3 keys) on and set the power switch to ON.)
7. Follow the adjustment procedure.

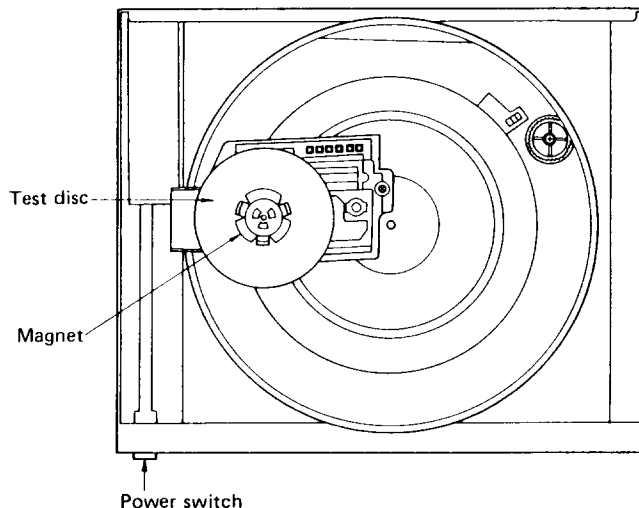

#### Measuring Instruments and Special Tools

- Test discs
  1. Test disc (SONY YEDS-18)
  2. Black band test disc (NR5A)
- Dual-beam oscilloscope with bandwidth of 30MHz or better (with EXT trigger and 1 : 1 probe).
- Audio frequency (AF) oscillator
- Allen wrench (M2.0)
- Allen wrench (M1.27)
- 0.9 mm clearance gauge

#### Perform adjustments depend on the part to be replaced according to followings:

- |                          |                |
|--------------------------|----------------|
| (1) Spindle motor .....  | Items 1,3 to 8 |
| (2) Turntable .....      | Items 1,3 to 8 |
| (3) Optical pickup ..... | Items 2 to 8   |

**Adjusting Procedure**

\* If you have replaced the optical pickup, spindle motor, or turntable, do the following adjustment:

**(1) TURNTABLE HEIGHT ADJUSTMENT**

1. Insert the 0.9 mm clearance gauge between the turntable and the loading base (see the figure at right).
2. Tighten the turntable retention screw with the 1.27 mm allen wrench.
3. Connect the oscilloscope's CH. 1 probe across VR104's **FEG** (+) and VR106's **V. REF** (-) terminals via a filter.  
(Note: A voltage of 2.5V appears at the V. REF terminal. Take care not to short the player's chassis to the oscilloscope ground.)  
Oscilloscope setting: VOLT ..... 50 mV  
SWEEP ..... 1 ms.  
Input coupling ... DC
4. Adjust oscilloscope's DC zero balance.
5. Switch the player power ON, and play the test disc (YEDS-18)
6. Measure the voltage amplitude of the signal on the oscilloscope.

Note 1. If the measured amplitude is within a range of +/- 15 mV, the turntable height is correct. If it is outside this range, adjust the turntable height by using the clearance gauge as a pry.

If the amplitude exceeds +15 mV, lower turntable.  
If the amplitude is below -15 mV, elevate the turntable.

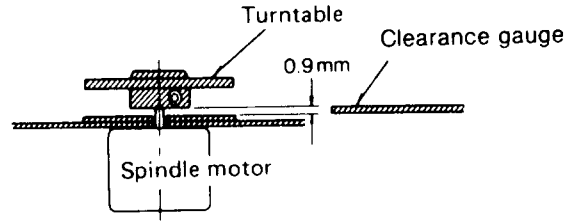

Note 2. If the measured amplitude greatly surpasses or falls short of the range above, set VR105 at or around the center, then try to adjust the height again. (Then be sure to adjust the focus offset as well.)

- Filter for turntable height adjustment  
Carbon resistor: 10kΩ  
Mylar capacitor: 0.1 μF

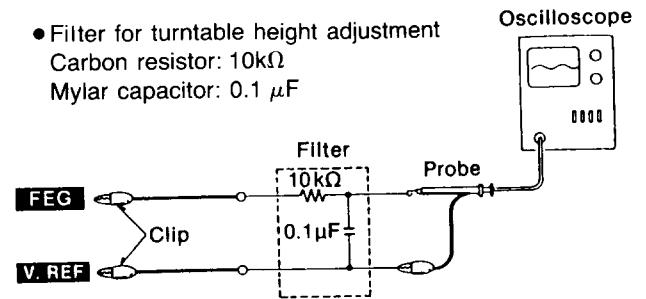

**ADJUSTMENT POINTS**

• Servo P.C.B.

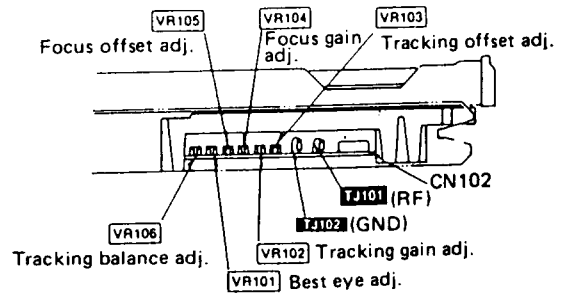
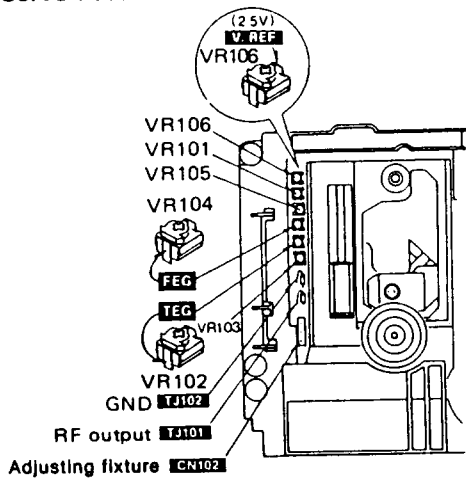

• Temporary setting of each VR

Temporary VR setting if any of the trimmer VRs are replaced or require readjustment, temporarily set them to the following positions:

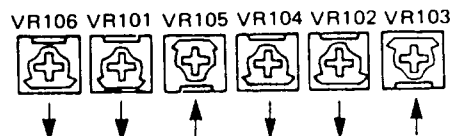

**(2) MECHANICAL ADJUSTMENT**

1. Connect the oscilloscope's CH. 1 probe across **TJ101** (+) and **TJ102** (-) on the Servo P.C.B.  
**Oscilloscope setting:** VOLT . . . . . 100 mV  
 SWEEP . . . . . 0.5  $\mu$ s.  
 Input coupling . . . AC
2. Switch the player power **ON**, and play track 18 on the test disc (YEDS-18). (Playing any other track may yield a false adjustment.)
3. Leave the player in Play mode, and place it as shown in the figure on the right.
4. Alternately adjust the two mechanical adjusting screws with the 2.0mm allen wrench until the vertical fluctuation of RF signal is minimized and the eye pattern is most stretched.
5. After completing the adjustment, lock the **mechanical adjustments** with lock paint.

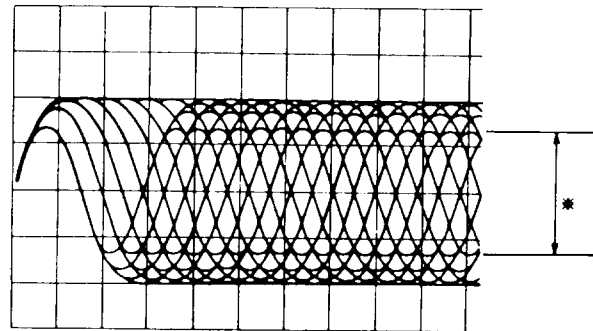
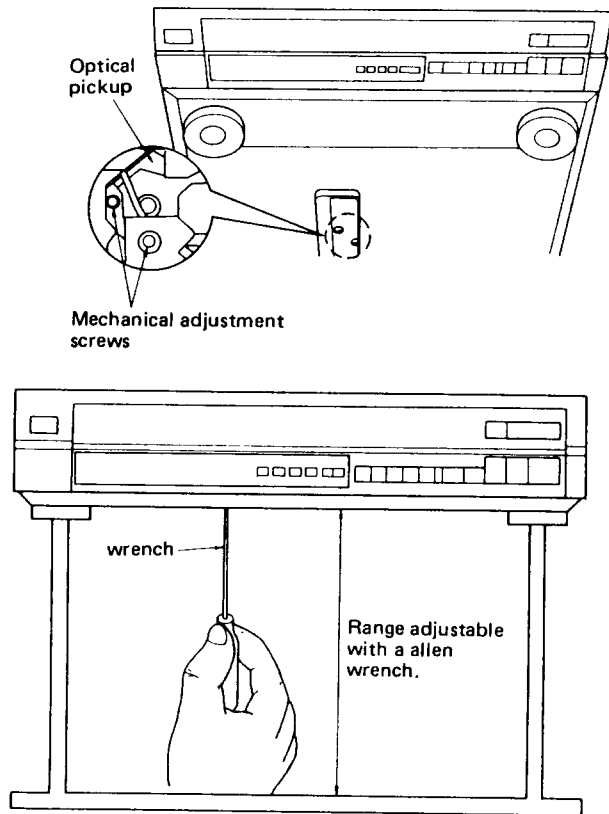

\* Most stretched eye pattern.

**(3) BEST EYE (PD BALANCE) ADJUSTMENT**

1. Connect the oscilloscope's CH. 1 probe across **TJ101** (+) and **TJ102** (-) on the Servo P.C.B.  
**Oscilloscope setting:** VOLT . . . . . 100 mV  
 SWEEP . . . . . 0.5  $\mu$ s  
 Input coupling . . . AC
2. Switch the player power **ON**, and play the 1 kHz (track 2) on the test disc (YEDS-18).
3. Adjust **VR101** until the vertical fluctuation of RF signal is minimized and the eye pattern is most stretched.

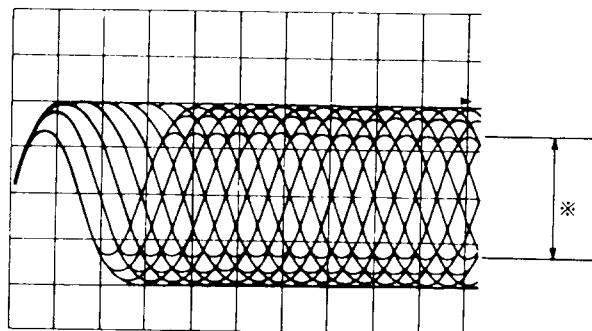

\* Most stretched eye pattern.

#### (4) FOCUS GAIN ADJUSTMENT

1. Set up the AF oscillator output for **825Hz, 150 mVp-p**, and connect it to pins 3 and 4 of adjusting fixture CN102 on the servo pc board.

2. Connect oscilloscope's CH. 1 and CH. 2 probes to the pins 3 and 4 of CN102, respectively (Pin 5 is GND).

**Oscilloscope setting:** VOLT ..... 100 mV  
 SWEEP ..... 0.2 ms.  
 Input  
 coupling ..... AC

3. Play the track 2 on the test disc (YEDS-18).

4. Adjust **VR104** until the signal amplitudes on both channels become identical to each other.

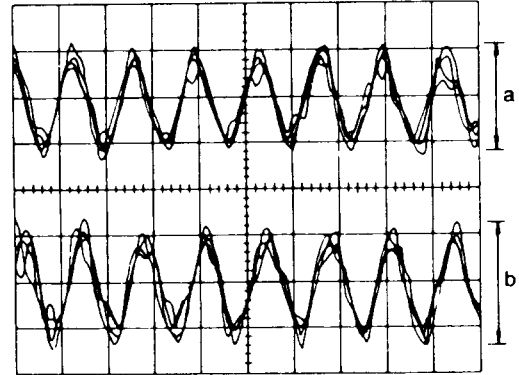

※ Adjust VR104 until a equals b.

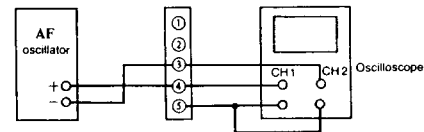

#### (5) TRACKING GAIN ADJUSTMENT

1. Set up the AF oscillator output for **1.1kHz, 150 mVp-p** and connect it to pins 1 and 2 of adjusting fixture CN102.

2. Connect oscilloscope's CH. 1 and CH. 2 probes to the Pins 1 and 2, respectively (Pin 5 is GND).

**Oscilloscope setting:** VOLT ..... 100 mV  
 (both channels)  
 SWEEP ..... 0.2 ms.  
 Input  
 coupling ..... AC

3. Switch the player power **ON**, and play the track 2 on the test disc (YEDS-18).

4. Adjust **VR102** until the signal amplitudes on both channels become identical to each other.

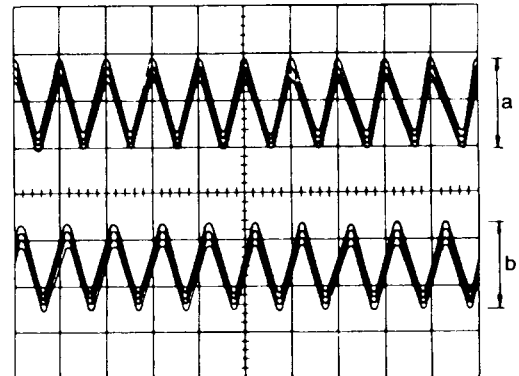

※ Adjust VR102 until a equals b.

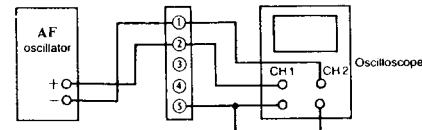

#### (6) FOCUS OFFSET ADJUSTMENT

1. Connect the oscilloscope's CH. 1 probe across **TJ101** (+) **TJ102** (-) on the Servo P.C.B. and its CH. 2 probe (+) to VR104's **FEB** terminal.

**Oscilloscope setting:** VOLT ..... 100 mV (CH. 1)  
 100 mV (CH. 2)  
 SWEEP ..... 0.2 ms.  
 Input  
 coupling ..... AC  
 Trigger mode .. NORM  
 (trigger CH. 1)

2. Switch the player power **ON**, and play track 13 on the test disc (NR5A).

3. Trigger the oscilloscope's CH. 1 so that the following waveforms are observed. Adjust **VR105** until the dip in the RF signal envelope on CH. 1 is smooth and the signal amplitude on CH. 2 is minimized, i.e. when amplitude A equals amplitude B.

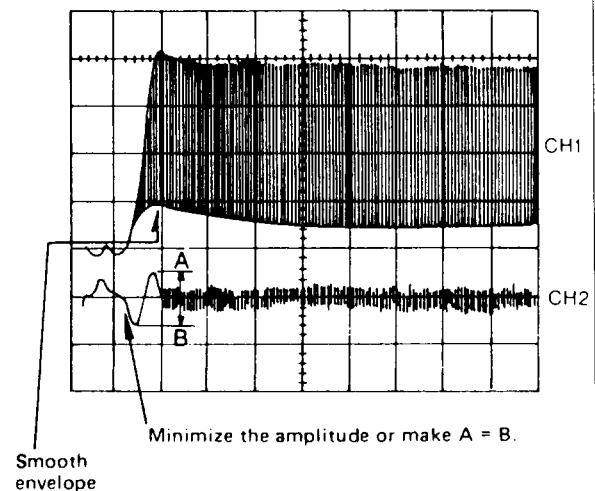

Minimize the amplitude or make A = B.

