

ONKYO® SERVICE MANUAL**COMPACT DISC CHANGER
MODEL DX-C140/DX-C340****Black and Silver models**

BMD	120V AC, 60Hz
BMP/BMPA/SMP	230V AC, 50Hz
BMWT	120/220V AC, 50/60Hz

SAFETY-RELATED COMPONENT WARNING!!

COMPONENTS IDENTIFIED BY MARK Δ ON THE SCHEMATIC DIAGRAM AND IN THE PARTS LIST ARE CRITICAL FOR RISK OF FIRE AND ELECTRIC SHOCK. REPLACE THESE COMPONENTS WITH ONKYO PARTS WHOSE PART NUMBERS APPEAR AS SHOWN IN THIS MANUAL.

MAKE LEAKAGE-CURRENT OR RESISTANCE MEASUREMENTS TO DETERMINE THAT EXPOSED PARTS ARE ACCEPTABLY INSULATED FROM THE SUPPLY CIRCUIT BEFORE RETURNING THE APPLIANCE TO THE CUSTOMER.

SPECIFICATIONS

Compact Disc Automatic Changer Model DX-C140/C340

Signal readout system:	Optical non-contact
Reading rotation:	About 500 - 200 r.p.m. (constant linear velocity)
Linear velocity:	1.2 - 1.4 m/s
Error correction system:	Cross Interleave Reed-Solomon code
D/A converter:	1 bit PWM/ACCUPULSE
Sampling frequency:	352.8 kHz (8 times oversampling)
Number of channels:	2 (stereo)
Frequency response:	5 Hz - 20 kHz
Total harmonic distortion:	0.005% (at 1 kHz)
Dynamic range:	96 dB
Signal to noise ratio:	92 dB
Channel separation:	92 dB (at 1 kHz)
Wow and Flutter:	Below threshold of measurability
Output level:	2 volts r.m.s.
Power consumption:	10 watts
Power supply:	
DX-C340:	120V, 60Hz 230V, 50Hz 220-230V/120V switchable, 50/60 Hz
DX-C140:	120V, 60 Hz
Dimensions (W x H x D):	435 x 131 x 433 mm (17-1/8" x 5-3/16" x 17-1/16")
Weight:	6.9 kg (15.2 lbs.)

Specifications and features are subject to change without notice.

ONKYO®
AUDIO COMPONENTS

TABLE OF CONTENTS

Specifications	1
Service procedures	2
Caution on replacement of optical pick-up	2
Protection of eyes from laser beam during servicing	3
Laser warning label	3
IC block diagram and descriptions	4
Microprocessor connection diagram	8
Microprocessor terminal description	9
Care should be taken with the optical pickup	10
Adjustment procedure	11
Pick-up drive unit/part list	12
Trouble shooting	13
Initializing operation	15
Error message displayed in heat-running mode	16
Chassis exploded view parts list	17
Changer mechanism parts list	18
Chassis exploded view	19
Block diagram	21
Schematic diagram	23
Printed circuit board view from bottom side	25
Printed circuit pc board-parts list	29
Packing view/parts list	31

SERVICE PROCEDURES

1. Safety-check out

After correcting the original service problem, perform the following safety check before releasing the set to the customer:

Connect the insulating-resistance tester between the plug of power supply cord and chassis.

Specifications: More than 10Mohm at 500V.

2. Voltage Selector (Back panel)

Worldwide models are equipped with a voltage selector to conform with local power supplies. Be sure to set this switch to match the voltage of the power supply in user's area before turning the power switch on.

Voltage is changed by sliding the groove in the switch with a screw driver to the right or left.

Confirm that the switch has been moved all the way to the right or left before turning the power switch on.

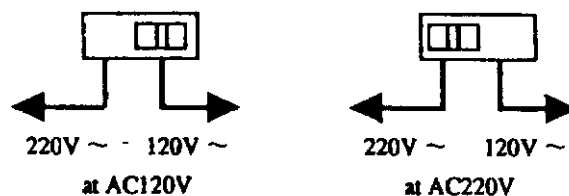

CAUTION ON REPLACEMENT OF OPTICAL PICK UP

The laser diode in the optical pickup block is so sensitive to static electricity, surge current and etc, that the components are liable to be broken down or its reliability remarkably deteriorated.

During repair, carefully take the following precautions. (The following precautions are included in the service parts.)

PRECAUTIONS

1. Ground for the work-desk.

Place a conductive sheet such as a sheet of copper (with impedance lower than 10MΩ) on the work-desk and place the set on the conductive sheet so that the chassis.

2. Grounding for the test equipment and tools.

Test equipments and toolings should be grounded in order that their ground level is the same the ground of the power source.

3. Grounding for the human body.

Be sure to put on a wrist-strap for grounding whose other end is grounded.

Be particularly careful when the workers wear synthetic fiber clothes, or air is dry.

4. Select a soldering iron that permits no leakage and have the tip of the iron well-grounded.

5. Do not check the laser diode terminals with the probe of a circuit tester or oscilloscope.

PROTECTION OF EYES FROM LASER BEAM DURING SERVICING

This set employs a laser. Therefore, be sure to follow carefully the instructions below when servicing.

WARNING!!

WHEN SERVICING, DO NOT APPROACH THE LASER EXIT WITH THE EYE TOO CLOSELY. IN CASE IT IS NECESSARY TO CONFIRM LASER BEAM EMISSION, BE SURE TO OBSERVE FROM A DISTANCE OF MORE THAN 30cm FROM THE SURFACE OF THE OBJECTIVE LENS ON THE OPTICAL PICK-UP BLOCK.

Laser Diode Properties

- Material: GaAlAs.
- Wavelength: 760~800nm
- Emission Duration: continuous
- Laser output: max. 0.5mW*

*This output is the value measured at a distance about 1.8mm from the objective lens surface on the Optical Pick-up Block.

LASER WARNING LABEL

These labels are located on the mechanism.

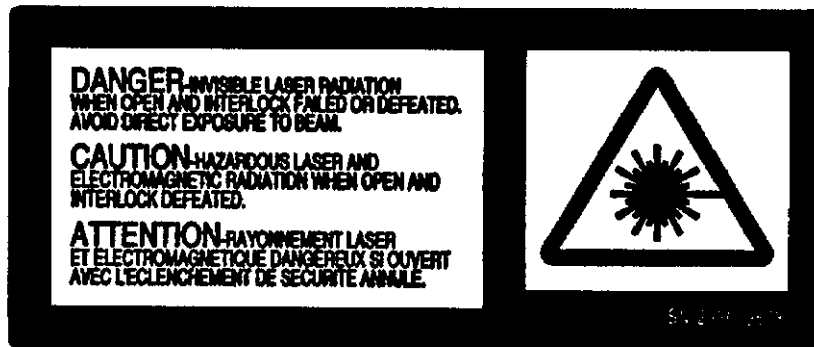
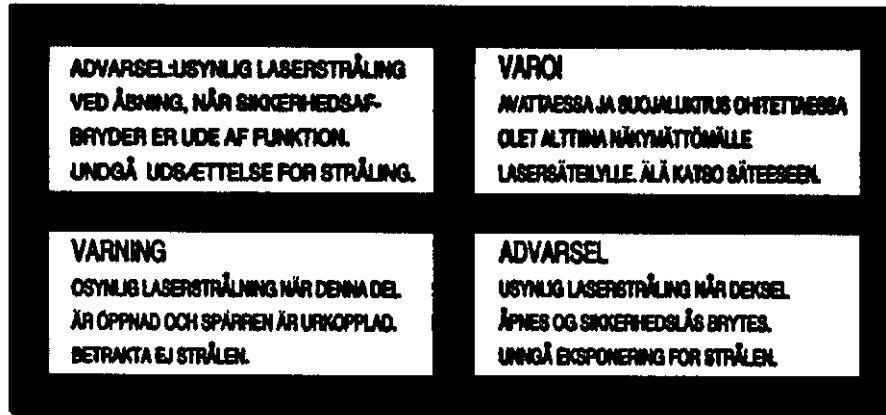

CAUTION ON REPLACEMENT OF OPTICAL PICKUP

The laser diode in the optical pickup block is so sensitive to static electricity, surge current and etc. that the components are liable to be broken down or its reliability remarkably deteriorated.

During repair, carefully take the following precautions.

1. When replacing the optical pickup, first short the LD terminals and remove the connector. Also, when attaching the new optical pickup, after attaching the connector, unsolder the LD terminals.
2. Do not touch the optical pickup object lens with the hands.

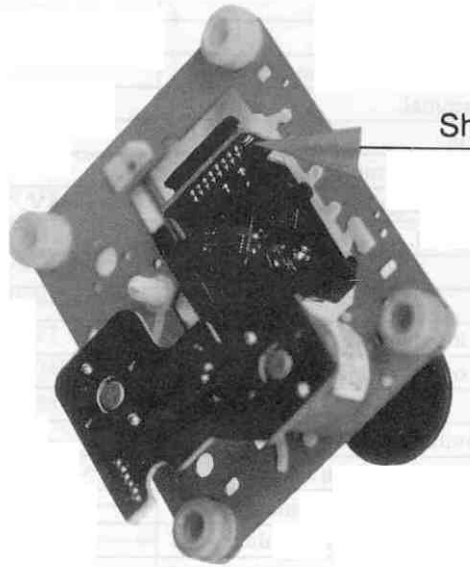

Short pattern for LD protection.

ADJUSTMENT PROCEDURES

Instruments required

Dual trace oscilloscope, Frequency counter, AF oscillator, Test disc (SONY YEDS-18) and AC voltmeter.

1. Focus offset adjustment

Turn R108 and R126 to the mechanical center.

Load the test disc YEDS-18 on the tray and play the track 2.

Connect the oscilloscope to terminal P106.

Adjust R108 until the waveform on the oscilloscope becomes maximum.

After adjustment, disconnect the oscilloscope.

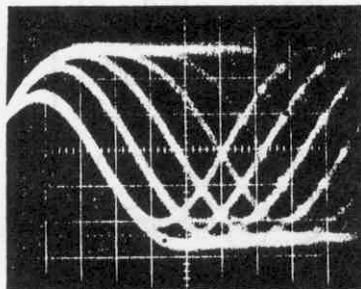
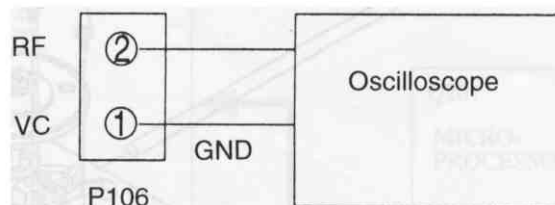

Photo 1

0.2V/div

0.2 μ s/div



2. Focus gain adjustment

Set the output of AF oscillator to 1KHz,—2 Vp-p.

Play the track 2 of test disc.

Connect the oscilloscope and the AF oscillator as shown below.

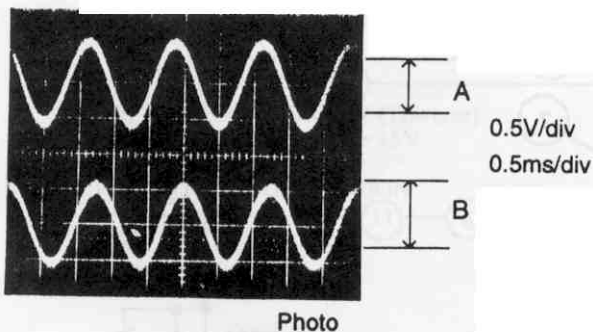

Photo

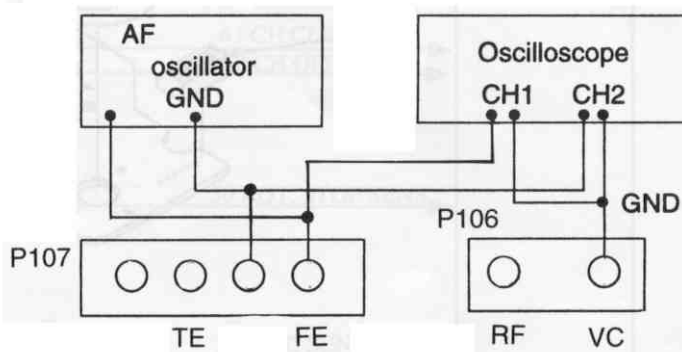

Adjust R126 until 1KHz components of channels 1 and 2 on oscilloscope become same level.

After adjustment, disconnect the AF oscillator and the oscilloscope.

PICK-UP DRIVE UNIT

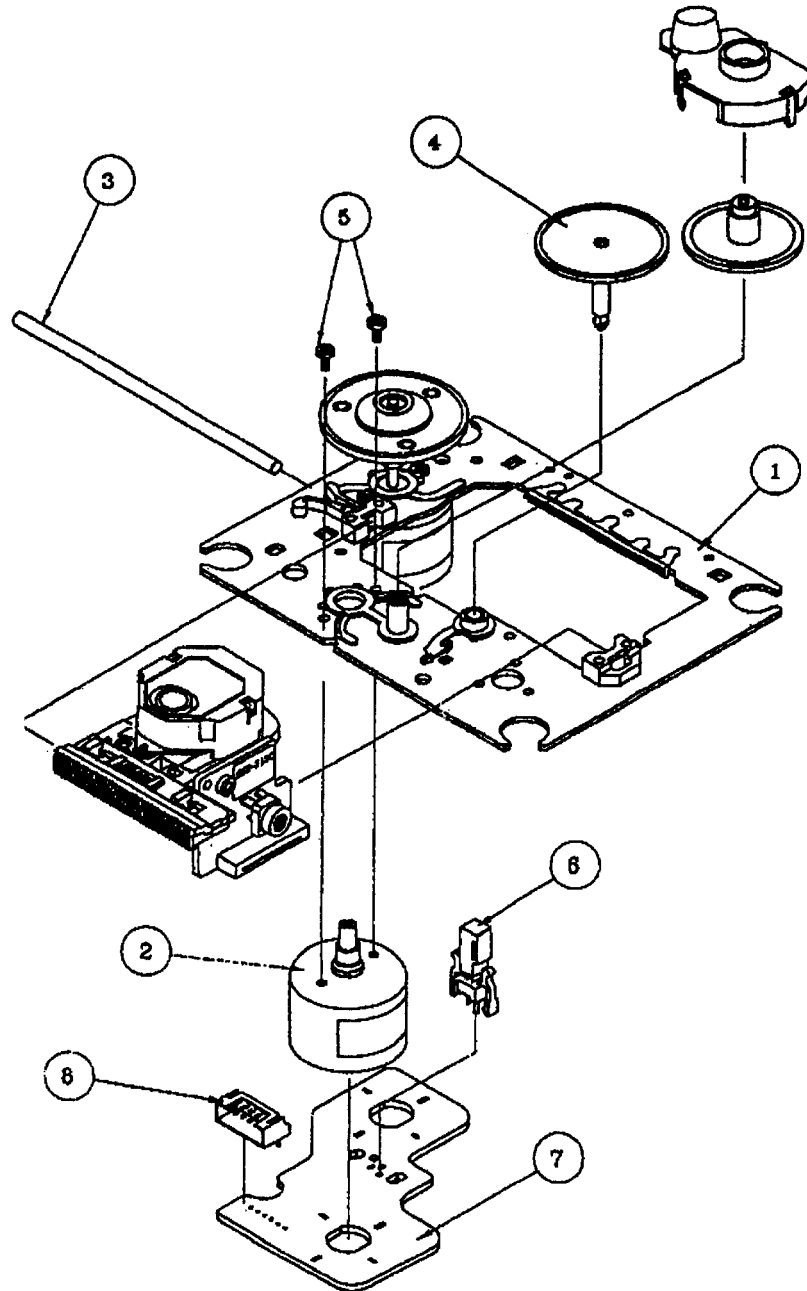

REF.NO.	PART NO.	DESCRIPTION
1	X2625-877- 1	Motor chassis ass'y (MB)
2	X2625-769- 1	Motor gear ass'y
3	2626-908- 01	Sled shaft
4	2626-907- 01	Gear (A)(S)
5	7621-255- 15	Screw +P2x3
6	1572-085- 11	Leaf switch
7	1639-678- 12	Motor (6P) (S) PCB
8	1564-722- 11	Connector pin 6P

TROUBLE SHOOTING

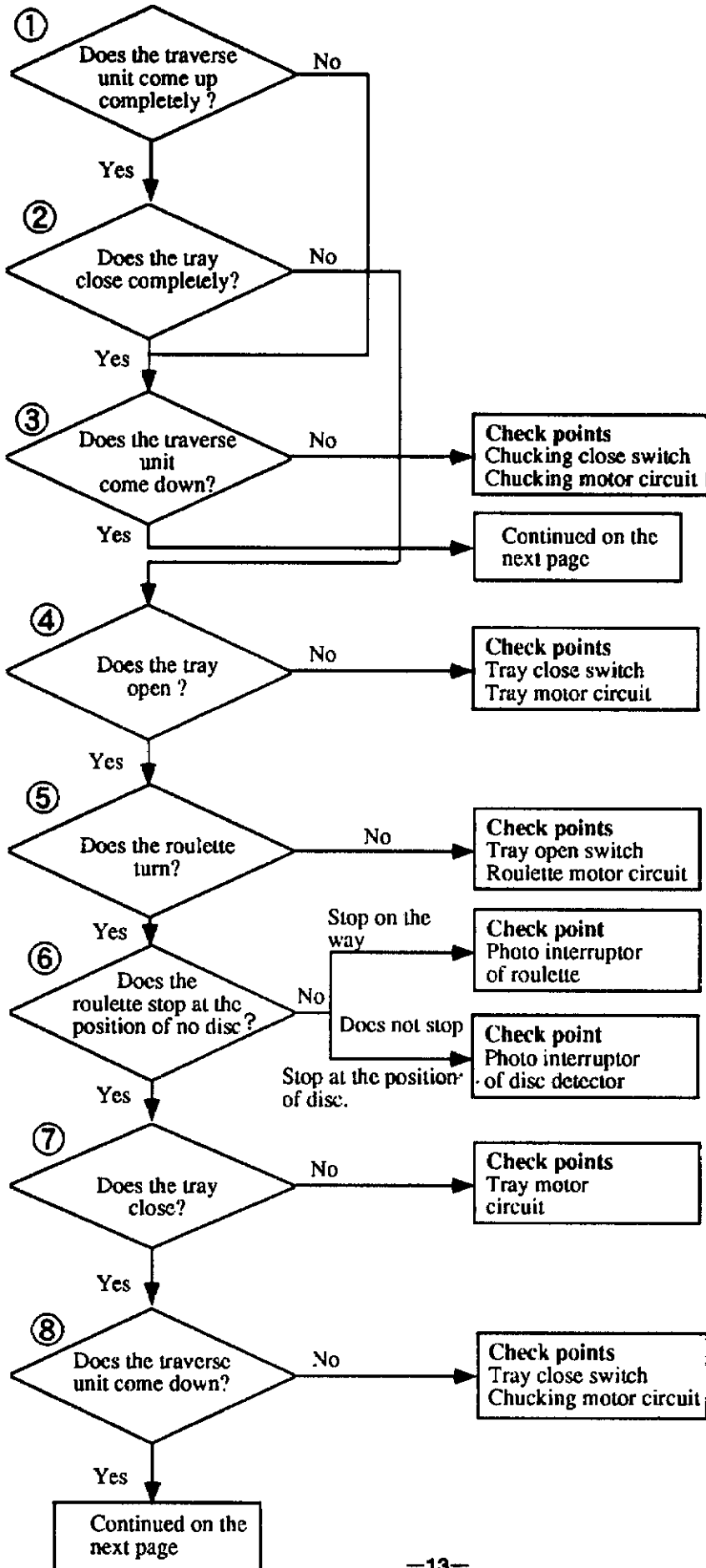

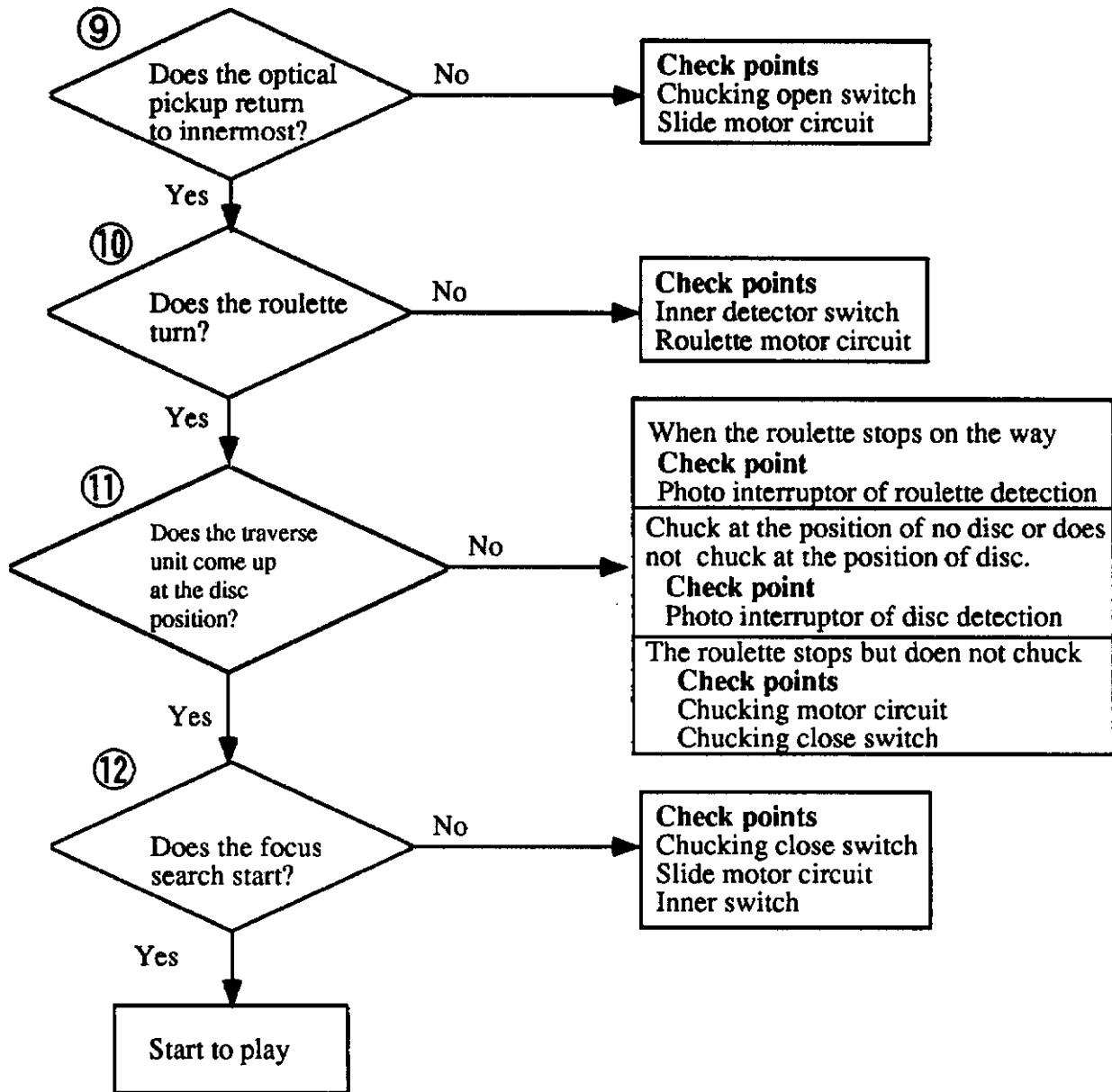

INITIALIZING OPERATION

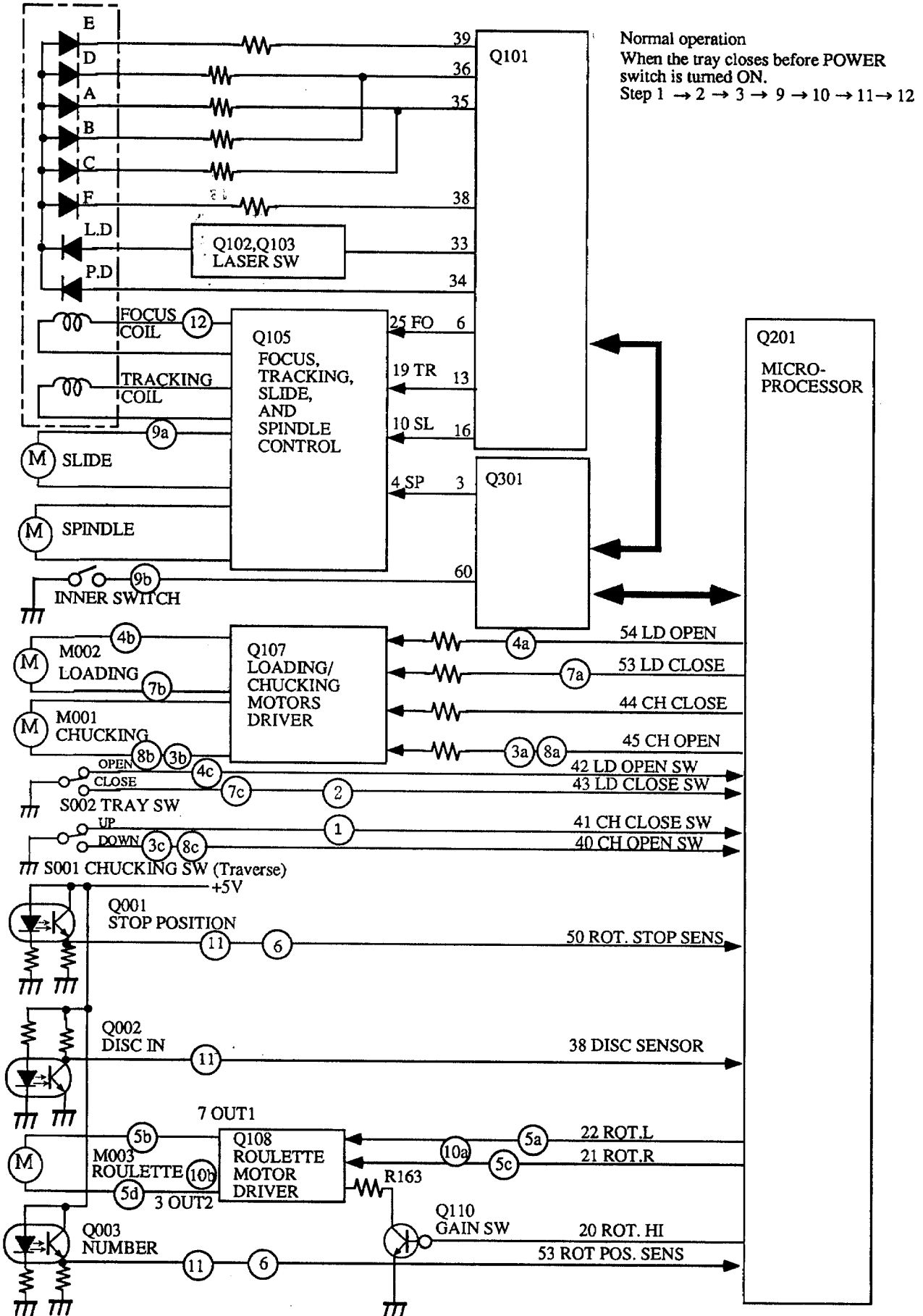

ERROR MESSAGE DISPLAYED IN HEAT-RUNNING MODE

Heat-running Mode : Power ON as pushing DOWN button together.

Operation :

1. DISC 1 chucking and TOC Reading (Pick-up Home position is displayed.)
2. Accessing of the Outermost Track
3. Tray Open
4. Tray Close
5. DISC 1 Playing / Stop and Chucking Down
6. Roulette Turning 7/6 Turns clockwise

Then,

1. DISC 2 chucking and TOC Reading (Pick-up Home position is displayed.)
2. Accessing of the Outermost Track
3. Tray Open
4. Tray Close
5. DISC 2 Playing / Stop and Chucking Down
6. Roulette Turning 5/6 Turns counter-clockwise

Then,

Continued as the above.

In these operation Error Message is shown in the display if any error occurs in the mechanism or the servo control. And then you can find the failure point almost exactly in this mode before you repair rejected units.

1. nf : FOCUS NG : FOCUS SERVO ON missed (Failure in Laser or RF circuit)
2. ng : GFS NG : TIMEOUT for Non-GFS (Synchronous Signal Detection) (Failure in RF Demodulator or CLV)
3. ld : TOC Reading NG : TIME OUT Before TOC Reading completion (All SERVO Circuit)
4. ac : ACCESS NG : TIME OUT before ACCESS completion (All SERVO Circuit)
5. co : CH OPEN NG : Non-CHUCKING Open
6. cc : CH CLOSE NG : Non-CHUCKING Close
7. rL : ROT LEFT NG : Non CCW Turning of Roulette or Non-Detection of CCW Turning of Roulette
8. rr : ROT RIGHT NG : Non CW Turning of Roulette or Non-Detection of CW Turning of Roulette
9. OP : TRAY OPEN NG : Non TRAY Open
10. CL : TRAY CLOSE NG : Non TRAY Close
11. PU : PICK UP RETURN NG : PICK-UP Non Return to the inner most.

There are two Errors in the normal operation as follows.

1. Er : INITIALIZE ERROR : Error occurred in Mechanism when it is initialized. (Error points are displayed in Heat-running Mode.)
2. rn : RAM NG : RAM for File is not Initialized.

CHASSIS EXPLODED VIEW PARTS LIST

REF. NO.	PART NO.	DESCRIPTION
A1	27110990	Front bracket
	27110991Y	Front bracket <S>
A2	838130088	3TTB+8B, Self-tapping screw
A3	28191776A	Clear plate
	28191777A	Clear plate <S>
A4	28325465Y	Knob (POW)
	28325466Y	Knob (POW) <S>
A5	27270400	Spacer (POW)
A6	27100327Y	Chassis
A7	27191000Y	Holder (MFS)
A8	260208	Wire tie
A13	27175316B	Leg
A14	28141332Y	Cushion
A17	27300750	▲ Cord bushing #2271
A19	29361957Y	Label (ALL2)
A20	831430088	3TTW+8(BC), Self-tapping screw
A22	27300833Y	Clump, WS-2NS
A23	27301779	Clump, HI-38-0
A24	838430107Y	3TTB+10S(BC), Self-tapping screw
A51	27122321Y	Rear panel <D> (Model DX-C340 only)
	27122324Y	Rear panel <DN> (Model DX-C140 only)
	27122322Y	Rear panel <P,PA> (Model DX-C340 only)
	27122323Y	Rear panel <WT> (Model DX-C340 only)
A301	28184680Y	Top cover
	28184681Y	Top cover <S>
A302	838430088Y	3TTB+8B(BC)
	838230088Y	3TTB+8B(NI) <S>
A501	27211904Y	Front panel (Model DX-C340 only)
	27211906Y	Front panel (Model DX-C140 only)
	27211905Y	Front panel <S> (Model DX-C340 only)
A502	28135244Y	Badge
	28135245Y	Badge <S>
A506	28148365Y	Door
	28148366B	Door <S>
E1	204329005Y	NCFC3-29005, Flexible flat cable
E2	204307007	NCFC3-07007, Flexible flat cable
P951	253192HIT	▲ AS-UC-6#18, AC Cord <D, DN>
	253193HIT	▲ AS-CEE, 250V 2.5A, AC Cord <P, WT>
	253197HIT	▲ AS-SAA, AC Cord <PA>
T901	2300992Y	▲ NPT-1200D, Power transformer <D>
	2300993Y	▲ NPT-1200P, Power transformer <P, PA>
	2300994Y	▲ NPT-1200DG, Power transformer <WT>
U1	1H358580-1AY	NAAR-5880-1A, Main circuit pc board <D,P,PA> (Model DX-C340 only)
	1H358580-1BY	NAAR-5880-1B, Main circuit pc board <WT> (Model DX-C340 only)
	1H357580-2AY	NAAR-5880-2A, Main circuit pc board <DN> (Model DX-C140 only)
U2	1H358581-1AY	NADIS-5881-1A, Display circuit pc board <D,P,PA> (Model DX-C340 only)
	1H358581-1BY	NADIS-5881-1B, Display circuit pc board <WT> (Model DX-C340 only)
	1H357581-2AY	NADIS-5881-2A, Display circuit pc board <DN> (Model DX-C140 only)
U3	1H358582-1AY	NAPS-5882-1A, Power supply circuit pc board <D,P,PA> (Model DX-C340 only)
	1H358582-1BY	NAPS-5882-1B, Power supply circuit pc board <WT> (Model DX-C340 only)
	1H357582-2AY	NAPS-5882-2A, Power supply circuit pc board <DN> (Model DX-C140 only)
U4	1H358583-1AY	NASW-5883-1A, Power switch pc board <D,P,PA> (Model DX-C340 only)
	1H358583-1BY	NASW-5883-1B, Power switch pc board <WT> (Model DX-C340 only)
	1H357583-2AY	NASW-5883-2A, Power switch pc board <DN> (Model DX-C140 only)
U11	1H357554-1Y	NAETC-5854, Position sensor pc board
U12	1H357555-1Y	NAETC-5855, Chacking motor pc board
U13	1H357556-1Y	NAETC-5856, Loading motor pc board
U14	1H357557-1Y	NASW-5857, Chacking switch pc board
U15	1H357558-1Y	NASW-5858, Roullet in/out pc board
U16	1H357559-1Y	NAETC-5859, Disc sensor pc board

NOTE: Black model only
 <S> Silver model only
 <D> 120V model only
 <P> 230V model only
 <PA> Australian model only
 <WT> Taiwan model only

NOTE: THE COMPONENTS IDENTIFIED BY MARK ▲ ARE CRITICAL FOR RISK OF FIRE AND ELECTRIC SHOCK. REPLACE ONLY WITH PART NUMBER SPECIFIED.

CHANGER MECHANISM PARTS LIST

REF. NO.	PART NO.	DESCRIPTION
M2	24840109Y	Rail
M3	28141337Y	Cushion
M6	24830004Y	Yoke (CHB)
M7	24824006Y	Cap (CHC)
M8	24832006Y	Magnet (CHB)
M10	24804015Y	Motor (RF-500TB-14415)
M11	24810028Y	Pulley
M12	24816010AY	Rubber belt (B)
M15	24810040Y	Gear (PULLEY)
M16	24810039A	Gear (LOAD)
M17	24810041Y	Cam gear (A)
M18	24810042Y	Cam gear (B)
M20	831430088Y	3TTW+8B(BC), Self-tapping screw
M23	24802024Y	Chassis (SUB)
M24	24840111Y	Self-tapping screw
M25	24800017Y	Mecha unit (KSM-213CCM)
M26	24818013Y	Insulator (A)
M27	24818014Y	Insulator (B)
M28	204416004Y	Flexible flat cable (NCFC4-16004)
M29	2009990464	Socket AS (NSAS-12P0618)
M30	24840111Y	Self-tapping screw
M33	24840107Y	Tray
M34	24804021Y	Motor (RF-310TA-11400)
M35	24810046	Pulley
M36	24822018Y	Retainer
M37	838130088Y	3TTB+8B, Self-tapping screw
M38	28141335Y	Cushion
M40	24810045Y	Worm AS
M43	24810043Y	Wheel gear
M44	831430088Y	3TTW+8B(BC), Self-tapping screw
M45	24834017Y	Spacer
M46	24840111Y	Self-tapping screw
M47	24816104	Rubber belt (E)
M48	24840110Y	Roller
M50	24840108Y	Roulette
M51	24834016Y	Washer (A)
M52	24820033Y	Spring (A)
M53	24840111Y	Self-tapping screw
M58	838130088Y	3TTB+8B, Self-tapping screw
M59	838426088Y	2.6TTB+8B(BC), Self-tapping screw

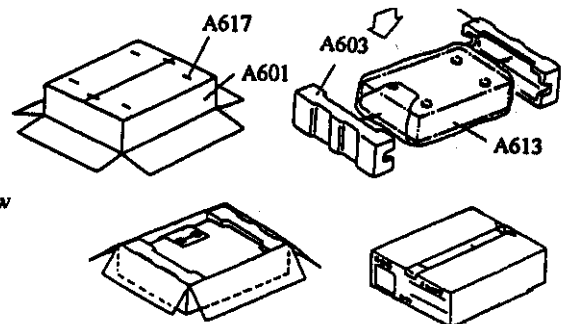

PACKING VIEW PARTS LIST

REF. NO.	PART NO.	DESCRIPTION
A601	29053143	Carton box (Model DX-C340 only)
	29053145Y	Carton box (Model DX-C140 only)
	29053144Y	Carton box <S> (Model DX-C340 only)
A603	29091774A	Pad (AS)
A613	29100153Y	Poly bag 720x1020
A617	282321Y	Staple
A604	29095795	Sheet (DR)
	Accessory bag ass'y	
	29342426Y	Instruction manual, E
	29342433Y	Instruction manual, T <WT>
	29342431Y	Instruction manual, U3(G,SW,D) <P>
	29342432Y	Instruction manual, U3(F,S,I) <P>
	29365019BY	Warranty card
	29365042	Warranty card <PA>
	29358002KY	Station list
	2010244Y or	Pin Cord AS
	2010098A or	
	2010326Y	
	2010200Y	3.5-mini plug, RI
	25055040	CV-K-2, Converter plug <WT>
	24140331Y	RC-331C, Remote control (Model DX-C340 only)
	3010165Y or	UM-3, Battery (Model DX-C340 only)
	3010194Y	
	27270397Y	Spacer, chassis
	29100097-1AY	Poly bag 350x250
	29360840Y	Label (Sheet)
	29362024-1Y	Label (UPC)AS <D> (Model DX-C340 only)
	29362202	Label (UPC)AS <DN> (Model DX-C140 only)
	29362161Y	Label (EAN)AS <P,PA,WT>
	29362162Y	Label (EAN)AS <S><P>
	29361786Y	Label (Malaysia) <WT>

CHASSIS EXPLODED VIEW

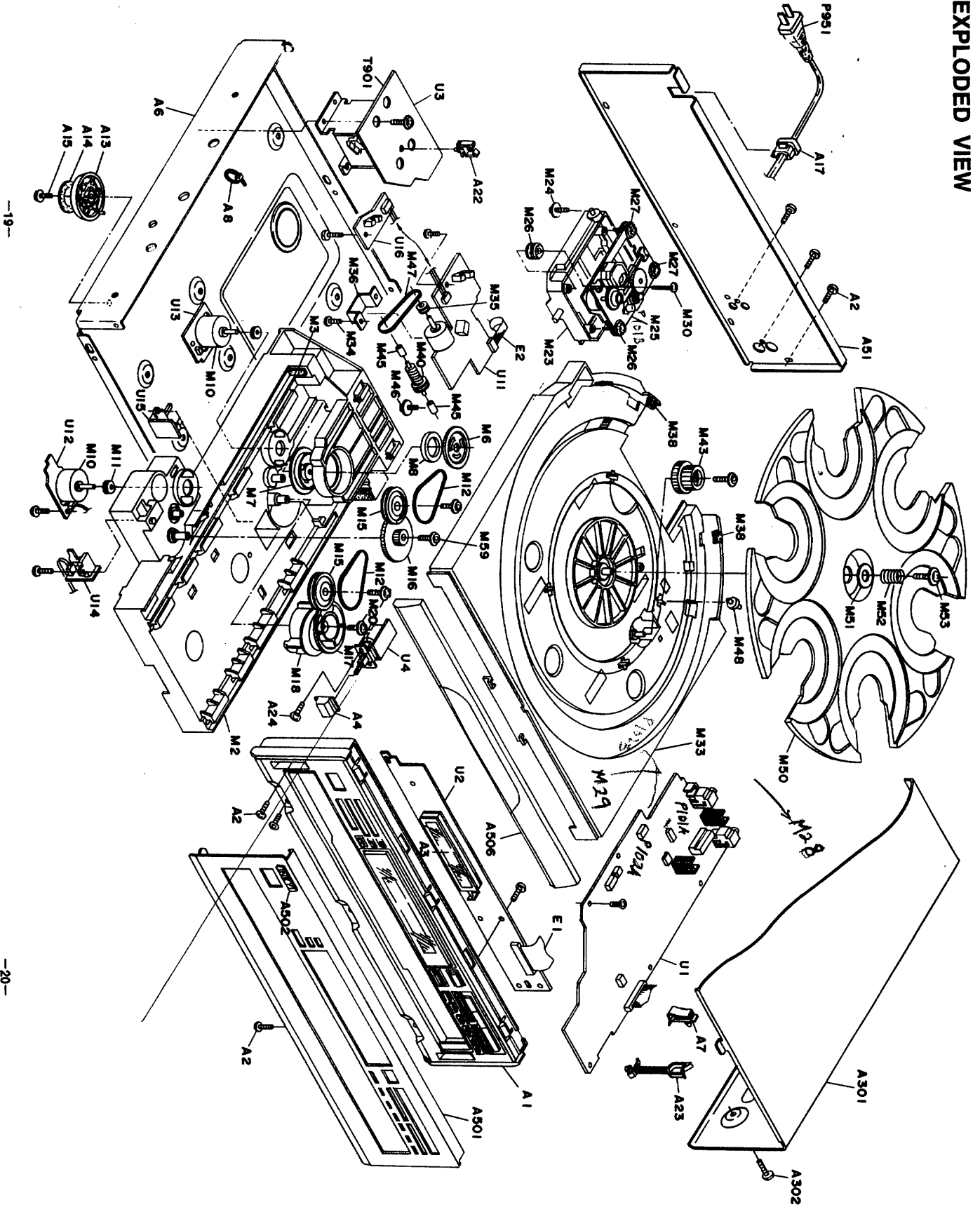

BLOCK DIAGRAM

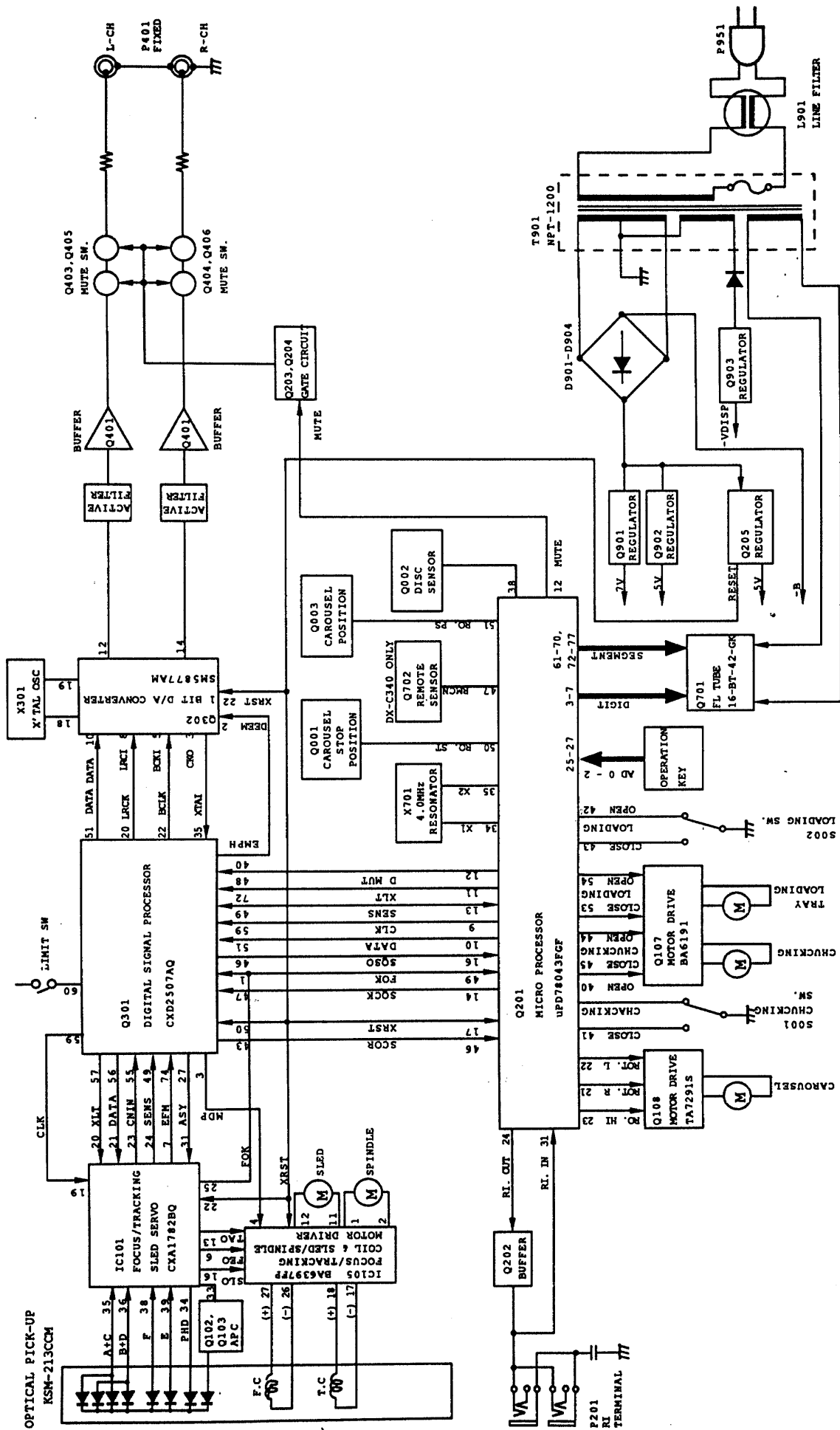

SCHEMATIC DIAGRAM

A B C D E F G

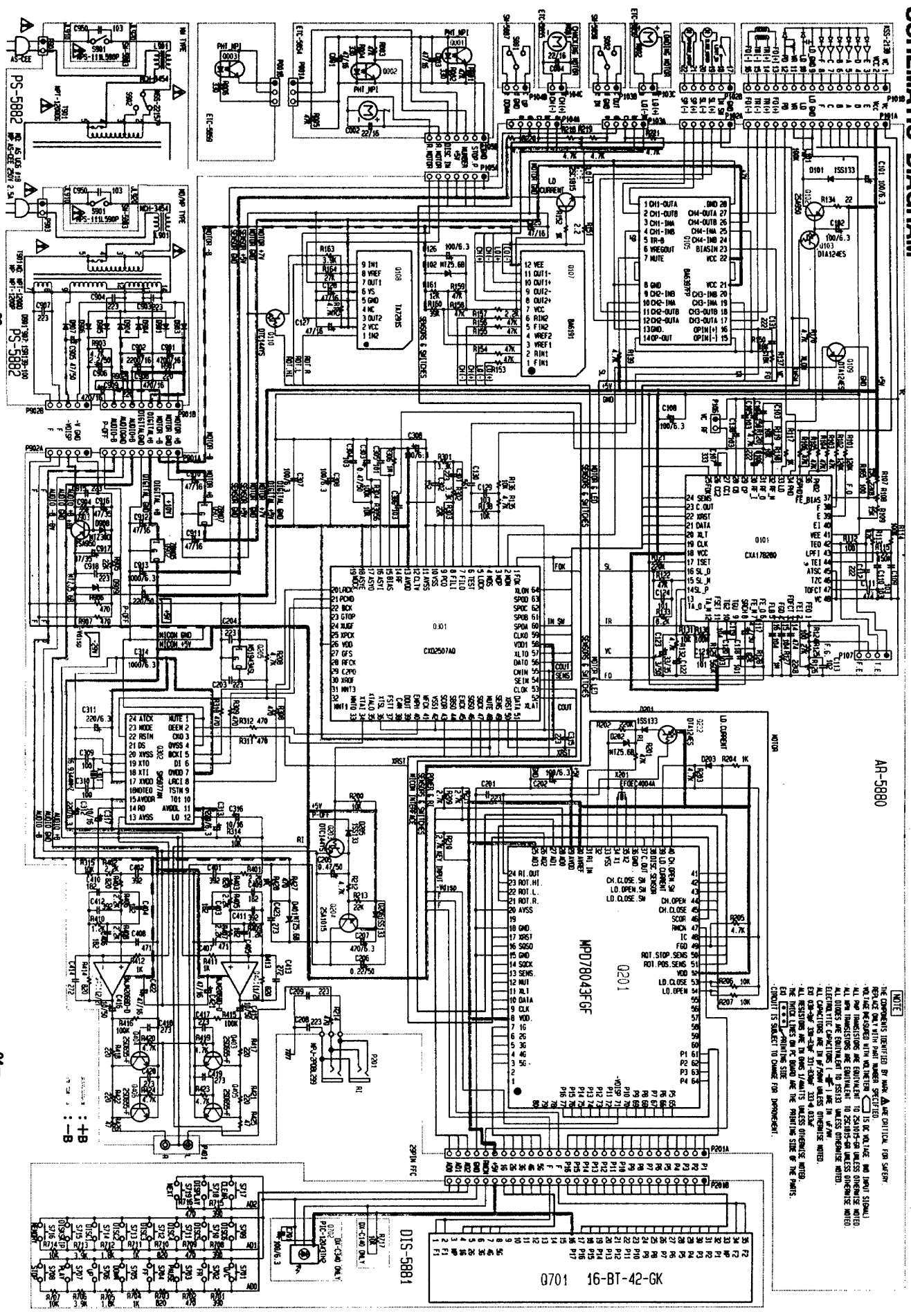

AR-5880

NOTE

COMPONENTS IDENTIFIED BY NAME ARE CRITICAL FOR SAFETY. THESE COMPONENTS MUST BE REPLACED WITH IDENTICAL OR EQUIVALENT PARTS TO MAINTAIN THE ORIGINAL SAFETY CHARACTERISTICS OF THIS EQUIPMENT. ALL PARTS IDENTIFIED BY NAME ARE AVAILABLE FROM THE MANUFACTURER OF THIS EQUIPMENT OR FROM THE EQUIPMENT MANUFACTURER. THE PART NUMBER IS PRINTED ON THE PARTS LIST.

REPLACEMENT PARTS MUST BE IDENTICAL TO THE ORIGINAL PARTS LIST OR THE EQUIPMENT MANUFACTURER'S LITERATURE. THE PART NUMBER IS PRINTED ON THE PARTS LIST.

THIS SCHEMATIC IS SUBJECT TO CHANGE FOR IMPROVEMENT.

PRINTED CIRCUIT BOARD — PARTS LIST

U1 MAIN CIRCUIT PC BOARD (NAAR-5888-1A/1B/2A)		CIRCUIT NO.		PART NO.		DESCRIPTION	
CIRCUIT NO.	PART NO.	DESCRIPTION	CIRCUIT NO.	PART NO.	DESCRIPTION	CIRCUIT NO.	PART NO.
Q101	Z2241093	IC	L101	233454K100	NCH-1452, 100K	U11 POSITION SENSOR PC BOARD (NAETC-5854-1)	Q001
Q105	Z2241066	CAV17B2BQ	P101	23051768	NSCT-16P1555	CIRCUIT NO.	Q002
Q108	Z2240229	BA6191	P105A	23051831	NSCT-7P1638	DESCRIPTION	Q002
Q201	Z2241094	MP78043EF-026	P202A	23051836	NSCT-29P1623		Q002
Q205	Z2240018	MS195GA	P102A	23053130	NPLG-6P134		P001A
Q301	Z2241096	CM20207AQ	P103A	23053149	NPLG-6P133		P103
Q302	Z224107489	SM4577AM	P104A	23053150	NPLG-6P134		P104
Q401	Z2239556	NIN20680-D	P106	23053038	NPLG-6P29		P106B
Q901	Z22780075	78M07BF	P107	23053045	NPLG-6P33		P107
Q902	Z22780035	78M05BF	P201	23045330	NP1-2PDBL184, RI		U12 CHA CKING MOTOR PC BOAR (NAETC-5853-1)
Q102, Q903	Z2211504	Transistors	P401	23045333	NP1-2PDBL195, Line out		CIRCUIT NO.
Q103, Q109, Q202	Z2212600	2S-A950-Y		Radial resistors	RAD51, Q901A		PART NO.
Q106	Z2212555	2SC1815-GR		27160145-1Y	RAD51, Q902A		DESCRIPTION
Q110, Q203	Z2212822	DTIC144ES		27160145-1Y			
Q204	Z2214455	2SA1015-GR					
Q403, Q406	Z2211706	2SD353-F					
D101, D201, D203, D205, D206	Diodes	1SS270A or 1SS133	U2 DISPLAY CIRCUIT PC BOARD (NADIS-5881-1A/1B/2A)				
D102, D202, D401	224470542	MIZ15.6B, Zener	CIRCUIT NO.				
D908	224472404	MIZ12.4D, Zener	PART NO.				
	224470512	MIZ15.1B, Zener	DESCRIPTION				
C101, C102, C108, C126, C202, C308	Capacitors	100 μ F, 6.3V, Elect.	U3 POWER SUPPLY CIRCUIT PC BOARD (NAIS-5882-1A/1B/2A)				
C105, C109, C110, C120, C129, C138, C304, C306	374721034	0.01 μ F, \pm 5%, 50V, Plastic	CIRCUIT NO.				
C106, C112, C131, C301, C313, C314, C417, C420, C423	374722224	2200 μ F, \pm 5%, 50V, Plastic	PART NO.				
C107	374723334	0.033 μ F, \pm 5%, 50V, Plastic	DESCRIPTION				
C111, C114	374724744	0.47 μ F, \pm 5%, 50V, Plastic					
C113	374721024	1000 μ F, \pm 5%, 50V, Plastic					
C115, C116, C119	374721044	0.1 μ F, \pm 5%, 50V, Plastic					
C117	354780479	4.7 μ F, 50V, Elect.					
C122	354780309	33 μ F, 50V, Elect.					
C123	354780339	3.3 μ F, 50V, Elect.					
C125, C127, C128, C235, C421, C422, C910, C911, C912	354780379	47 μ F, 16V, Elect.					
C303, C303	354784799	0.47 μ F, 50V, Elect.					
C306	354782299	0.22 μ F, 50V, Elect.					
C307, C313	354781029	1000 μ F, 6.3V, Elect.					
C315, C316	354781019	100 μ F, 50V, Elect.					
C302	354722219	220 μ F, 6.3V, Elect.					
C311, C312, C313	354724719	470 μ F, 6.3V, Elect.					
C314	354724719	10 μ F, 16V, Elect.					
C316, C317	354723924	3900 μ F, \pm 5%, 50V, Plastic					
C401, C402	354781009	10 μ F, 50V, Elect.					
C403, C406, C409, C410	354784709	47 μ F, 35V, Elect.					
C407, C408	374724714	470 μ F, \pm 5%, 50V, Plastic					
C411, C412	374723924	3900 μ F, \pm 5%, 50V, Plastic					
C413, C416	354781009	10 μ F, 50V, Elect.					
C316, C317	354784709	47 μ F, 35V, Elect.					
R108, R126	Resistors	N06HR, 20K Ω C, Thin					
R217	5210263	RMI/10L, 100K-5, R net					
X301	4916104405	Ceramic block					
	3010729	ER08C4004S4					
	3010159	Resistor					
		AT-38-169, Crystal					

NOTE: THE COMPONENTS IDENTIFIED BY MARE Δ ARE CRITICAL FOR RISK OF FIRE AND ELECTRICAL SHOCK. REPLACE ONLY WITH PART NUMBER SPECIFIED.