

# ONKYO SERVICE MANUAL

## COMPACT DISC CHANGER MODEL DX-C34

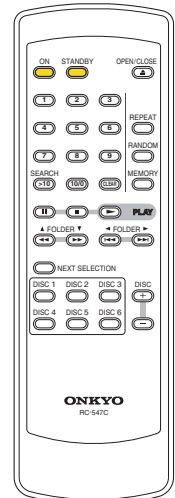
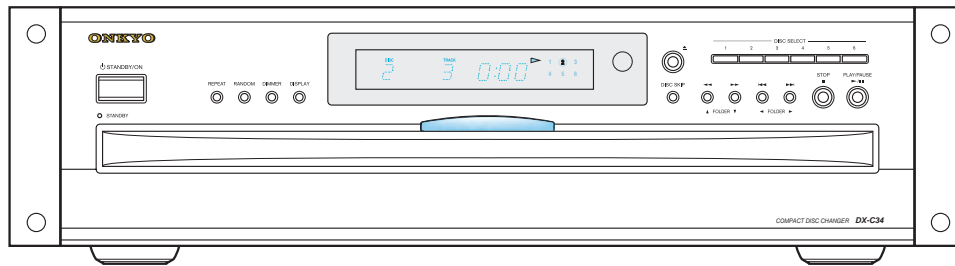

RC-547C

### Black model

BCDD	120V AC, 60Hz
------	---------------

### SAFETY-RELATED COMPONENT WARNING!!

COMPONENTS IDENTIFIED BY MARK  ON THE SCHEMATIC DIAGRAM AND IN THE PARTS LIST ARE CRITICAL FOR RISK OF FIRE AND ELECTRIC SHOCK. REPLACE THESE COMPONENTS WITH ONKYO PARTS WHOSE PART NUMBERS APPEAR AS SHOWN IN THIS MANUAL.

MAKE LEAKAGE-CURRENT OR RESISTANCE MEASUREMENTS TO DETERMINE THAT EXPOSED PARTS ARE ACCEPTABLY INSULATED FROM THE SUPPLY CIRCUIT BEFORE RETURNING THE APPLIANCE TO THE CUSTOMER.

## SPECIFICATIONS

### Specifications

#### DX-C34 (Compact Disc Changer)

Signal readout system .....	Optical non-contact
Frequency response .....	5 Hz-20 kHz
SN ratio .....	98 dB
Audio Dynamic range .....	96 dB
THD (Total harmonic distortion) .....	0.005% (at 1 kHz)
Audio output (Digital/Optical) .....	-22.5 dBm
Audio output/Impedance (Digital/Coaxial) .....	0.5 V (p-p) / 75 ohm
Audio output/Impedance (Analog) .....	2.0 V (rms) / 470 ohm
Power supply rating .....	AC 120 V 60 Hz
Power consumption .....	10 W
Standby power consumption .....	4 W
Dimensions (W x H x D) .....	19" x 5-3/16" x 17" (483 x 131 x 432 mm)
Weight .....	16.5 lbs. (7.5 kg)
Operating conditions Temperature/Humidity .....	41-95° F (5-35° C) / 25-80%
Disc compatibility .....	CD, CD-R, CD-RW

#### RC-547C (Remote Controller)

Transmitter .....	Infrared
Signal range .....	Approx. 16 ft., 5 meters
Power supply .....	Two (AA/R6) batteries (1.5 V x 2)

Specifications and features are subject to change without notice.

## SERVICE PROCEDURES

### PROTECTION OF EYES FROM LASER BEAM DURING SERVICING

This set employs a laser. Therefore, be sure to follow carefully the instructions below when servicing.

#### WARNING!!

**SERVICE WARNING : DO NOT APPROACH THE LASER EXIT WITH THE EYE TOO CLOSELY. IN CASE IT IS NECESSARY TO CONFIRM LASER BEAM EMISSION, BE SURE TO OBSERVE FROM A DISTANCE OF MORE THAN 30cm FROM THE SURFACE OF THE OBJECTIVE LENS ON THE OPTICAL PICKUP BLOCK.**

#### LASER WARNING LABEL

The labels shown below are affixed.

##### Warning label



##### DANGER:

INVISIBLE LASER RADIATION WHEN OPEN AND INTERLOCK FAILED OR DEFEATED. AVOID DIRECT EXPOSURE TO BEAM.

##### CAUTION:

HAZARDOUS LASER AND ELECTROMAGNETIC RADIATION WHEN OPEN AND INTERLOCK DEFEATED.

##### ATTENTION:

RAYONNEMENT LASER ET ELECTROMAGNETIQUE DANGEREUX SI OUVERT AVEC L'ECLANCHEMENT DE SECURITE ANNULE.

#### Safety check out (Only U.S.A. model)

After correcting the original service problem perform the following safety check before releasing the set to the customer.

Connect the insulating-resistance tester between the plug of power supply cord and terminal GND on the back panel.

Specifications: More than 10 M ohm at 500V.

#### Initializing the unit

Press "STOP" key and "STANDBY" key at same time. Displayed "INITIALIZE" on the FL display.

# EXPLODED VIEW

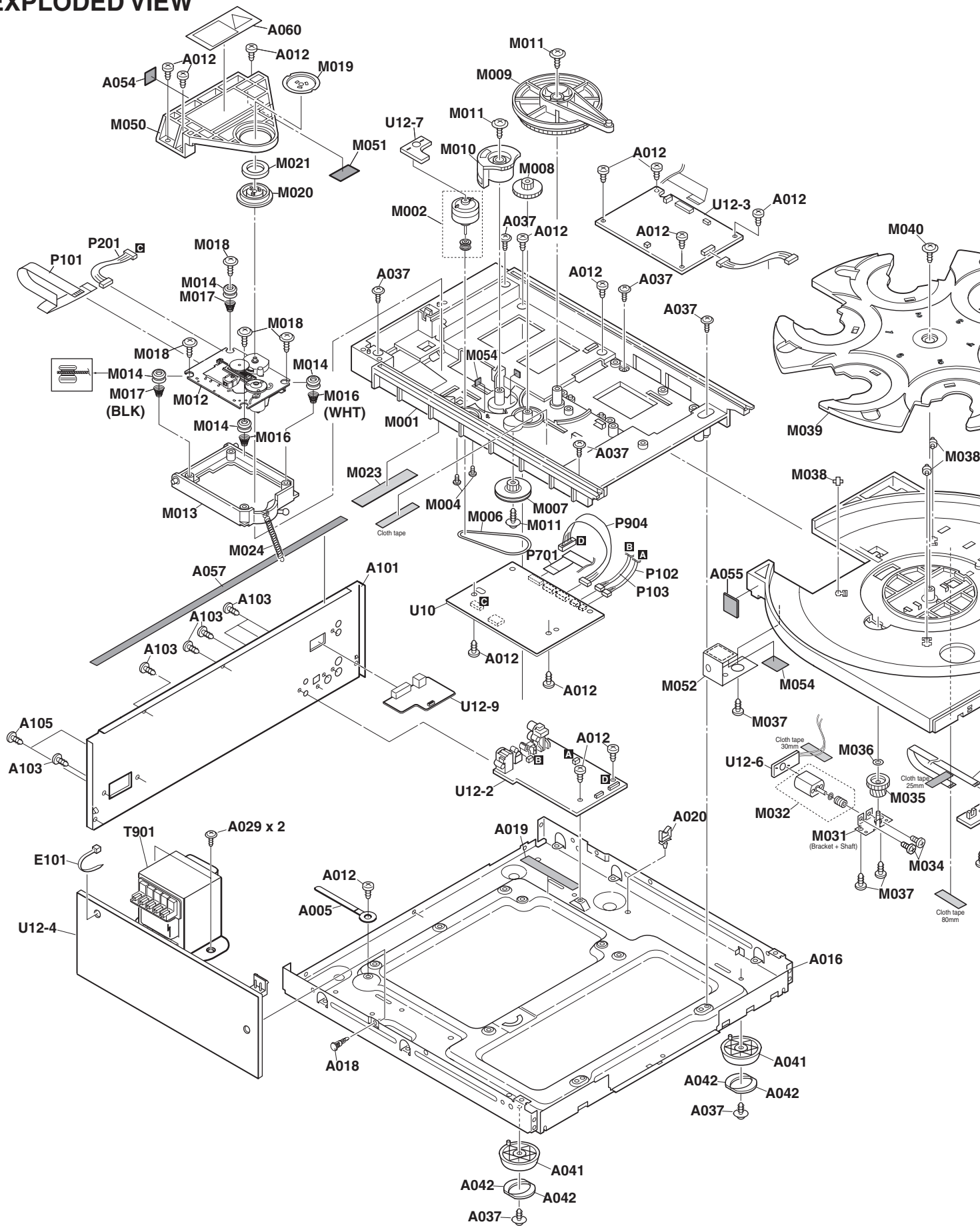

EXPLODED VIEW

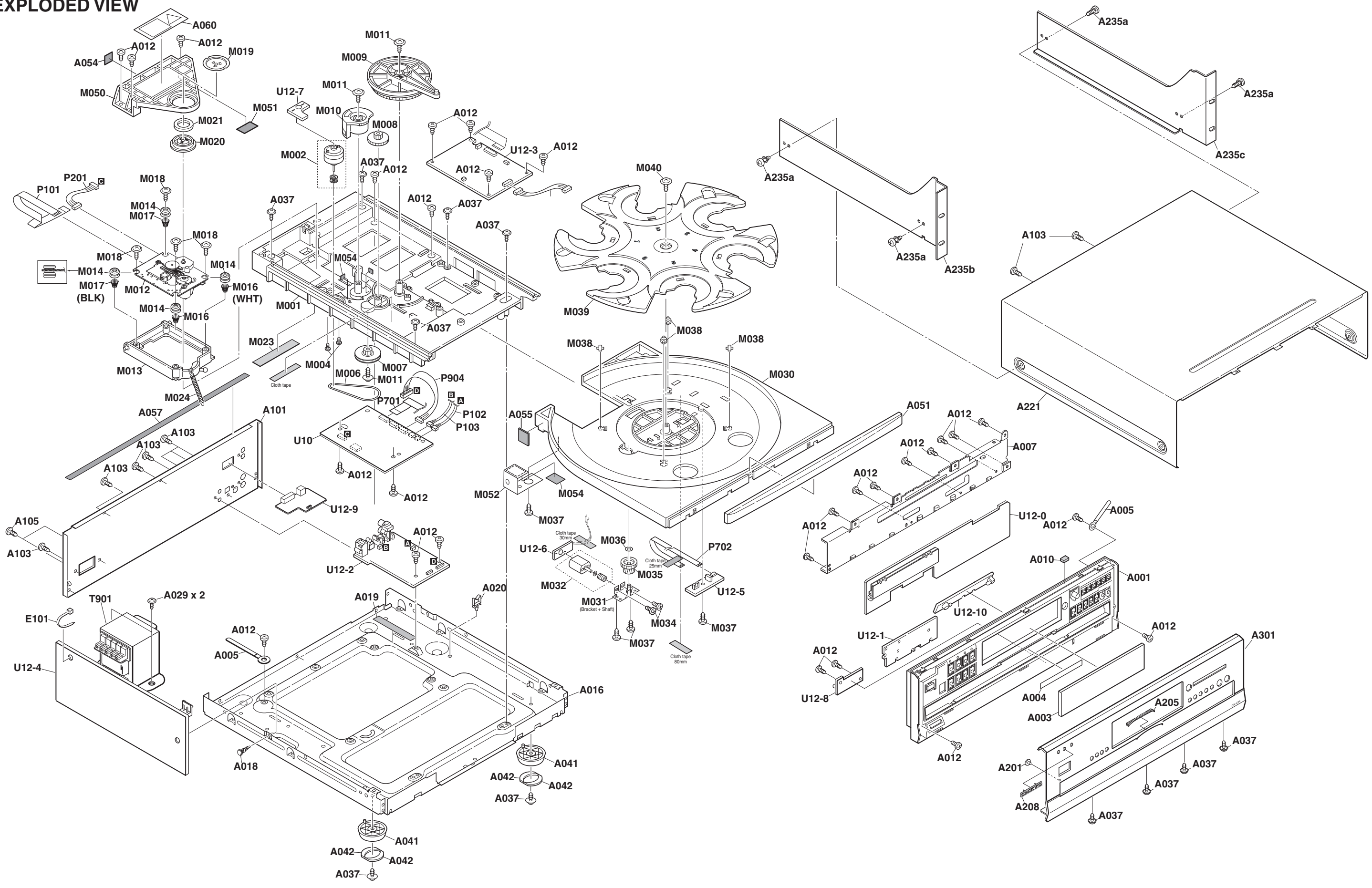



## EXPLODED PARTS LIST

N: New Part, !: Safety Part, NSP: Not Service Part

REF. NO.	PARTS NAME	DESCRIPTION	PART NO.	REMARKS	Q'TY
A001	F BRACKET		4154-7201-1		1
A003	CLEAR PLT	--	3716-9611-0		1
A004	SHEET	(F)	3000-9707-1		1
A005	CLIP	CS-1U	4135-3291-0		2
A007	BRACKET	(F)	4135-4031-1		1
A010	CUSHION	--	4149-0551-0		1
A012	SCREW	3TTB+8B	2854-3008-0000		26
A016	CHASSIS	--	1404-7611-2		1
A018	HOLDER	KGLS-10RT	4154-5291-0		1
A019	CUSHION	--	4157-0571-0		1
A020	WS CLAMP	CLAMP WS-2W	6360-9640-0		1
A029	SCREW	4TTC+6C(BC)	2A44-4006-3010		2
A037	SCREW	3TTW+8B(BC)	2950-3008-3010		11
A041	LEG	LEG	4154-6171-0		4
A042	CUSHION	--	4157-0311-0		8
A051	DOOR	(TRAY)	4154-6121-2		1
A054	SHEET	(BUTYL)t0.75x20x20	4157-0551-0		1
A055	SHEET	(BUTYL)	4157-0561-0		1
A057	TAPE	CLOTH-8U	1635-0110-0		1
A060	LABEL	RG-309250-1	3000-9670-0		1
A101	REAR PANEL	--	1405-0812-0	N	1
A103	SCREW	3TTB+8B(BC)	2954-3008-3000		16
A105	SCREW	4TTB+8C(BC)	2954-4008-3000		2
A201	FACET	(S)	3716-9806-0		1
A205	FACET	(LIGHT)	3716-9706-1		1
A208	BADGE	BADGE	4154-6151-0		1
A221	COVER	--	1404-9401-0		1
A235a	SCREW	3SMS8W.SW+14B(BC)	2956-3014-3030		{ 4 }
A235b	BRACKET	(L)	4135-5641-0		{ 1 }
A235c	BRACKET	(R)	4135-5651-0		{ 1 }
A301	F PANEL	--	1405-0704-0	N	1
E101	WIRE TIE	BSK-1	6360-9570-0		5
P101	FFC	NCFC2-162512	7012-6673-0		1
P102	SOCKET AS	001-0406-H	7012-6674-0		1
P103	SOCKET AS	001-0416-H	7012-6671-0		1
P201	SOCKET AS	NSAS-12P0960	7012-6524-0		1
P701	FFC	NCFC5-172012	7012-6670-0		1
P702	FFC	NCFC6-063012	7012-6522-0		1
P904	SOCKET AS	NSAS-20P1240	7012-6711-0		1
T901	P TRANS	NPT-1480D	1806-3681-0	!	1
U10	Main circuit board ass'y	NADG-8053-1D	PCB-Q01B0C-MPEGA		1
U12	Display circuit board ass'y	NADIS-8054-1D	PCB-Q01B0C-MAINA	NSP	1
U12-0	Front display board ass'y	NADIS-8054-1D	1H528554-1D		1
U12-1	Standby LED board ass'y	NADIS-8055-1D	1H528555-1D		1
U12-2	Output terminal board ass'y	NAAR-8056-1D	1H528556-1D		1
U12-3	Mechanism control board ass'y	NAAR-8057-1D	1H528557-1D		1
U12-4	Power transformer board ass'y	NAPS-8058-1D	1H528558-1D		1
U12-5	Disc sensor board ass'y	NAETC-8059-1D	1H528559-1D		1
U12-6	Roulette motor board ass'y	NAETC-8060-1D	1H528560-1D		1
U12-7	Loading motor board ass'y	NAETC-8061-1D	1H528561-1D		1
U12-8	Connection board	NAETC-8062-1D	1H528562-1D		1
U12-9	RS-232C terminal board ass'y	NADG-8065-1D	1H528565-1D		1
U12-10	Illumination board ass'y	NADIS-8066-1D	1H528566-1D		1
U12-11	Inlet terminal board ass'y	NAPS-8064-1D	1H528564-1D		1

**PACKING VIEW PARTS LIST**

**DX-C34**

REF. NO.	PARTS NAME	DESCRIPTION	PART NO.	REMARKS	Q'TY	PAGE
A235d	POLY BAG	t0.1*70*100	1497-7682-0-*		{ 1 }	
A235e	WASHER	(NYLON)	2639-0001-0-*		{ 8 }	
A235f	WASHER	SW	2639-0002-0-*		{ 8 }	
A235g	SCREW	10-32UNF	2A00-0004-Z00Z-*		{ 8 }	
A235h	F PANEL	--	1405-5701-0-*		{ 1 }	
A235i	LABEL	(TOP)	3001-0384-0-*		{ 1 }	
A235J	POLY BAG	t0.1*90*600	1497-7692-0-*		{ 1 }	
A603a	PAD	(L)	1490-4491-0	N	{ 1 }	
A603b	PAD	(R)	1490-4501-0	N	{ 1 }	
A604	SHEET	(DR)	4154-6221-0		1	
A605	SHEET	--	1450-6910-0		1	
A607	POLY BAG	850 x 650	1497-7462-0		1	
A610	PP TAPE	W48 OPP TAPE	9500-0070-0		2	
A641	CARTON	--	1437-4301-0-2	N	1	
A651	UPC LABEL	--	3001-0379-0	N	1	
A652	WRNTY CARD	(ONKYO)	3050-2491-1		1	
A655	INST SHEET	--	3050-3431-0-*		1	
A701	POLY BAG	350*250	1497-7382-0		1	
A801	CORD AS	PIN CORD AS	7012-6655-0		1	
A802	PLUG CORD	3.5-MINI PLUG (RI)	7012-6539-0		1	
A803	REMO CON	RC-547C	8912-0044-0		1	
A804	BATTERY	R6/AA(UM-3)	4060-0930-0		2	
A911	INS MANUAL	En(DXC34)	4301-7185-0	N	1	
P901	AC CORD	AS-UC-2	7012-6595-0	!	1	
P901 or	AC CORD	AS-UC-2	7012-6780-0	!	(1)	
P901 or	AC CORD	AS-UC-2	7012-6782-0	!	(1)	

**CHANGER MECHANISM PARTS LIST**

**DX-C34**

REF. NO.	PARTS NAME	DESCRIPTION	PART NO.	REMARKS	Q'TY
M001	RAIL	--	4154-6031-2		1
M002	Loding motor AS	Motor+Pulley	SVCQ0090CMOTCC		1
M002	MOTOR	CCM07B-045R1-1A	8913-6002-1	NSP	1
M003	PULLEY	--	4154-6001-0	NSP	1
M004	SCREW	2.6TTP+4S	2900-2604-0000		1
M005	TAPE	CLOTH-8U	1635-0110-0		1
M006	RBR BELT	DVCP701	4157-0281-0		1
M007	GEAR	(PULLEY)	4154-6061-0		1
M008	GEAR	(A)	4154-6091-0		1
M009	GEAR	(MAIN)	4154-6071-1		1
M010	GEAR	(CAM)	4154-6101-0		1
M011	SCREW	SCREW	4135-3301-0		1
M012	MECHA UNIT	KSM-213CLCM	4102-6244-0		1
M013	CHASSIS	(SUB)	4154-6041-1		1
M014	INSULATOR	(CDC-A)	4154-7211-0		1
M016	SPRING	(CDC-A)	2510-3661-1		1
M017	SPRING	(CDC-B)	2510-3671-1		1
M018	SCREW	SCREW	4135-3301-0		1
M019	CAP	(CHC)	4154-6161-0		1
M020	YOKE	(CHB)	4135-3201-1		1
M021	MAGNET	(CHB)	4135-3211-0		1
M022	SCREW	3TTB+8B	2854-3008-0000		1
M023	CUSHION	--	4157-0571-0	N	1
M024	SPRING	(DV-CP701)	2510-3591-0		1
M030	TRAY	--	4154-6011-5		1
M031	BRACKET AS	(M)	8901-4650-1		1
M031a	BRACKET	(M)	--	NSP	1

M031b	SHAFT	(M)	--	NSP	1
M032	Roulette motor AS	Motor+Worm gear	SVCQ0090CMOTPW		3/3
M032	MOTOR	PWN10EA02D	--	NSP	1
M033	GEAR	(WORM)	--	NSP	1
M034	SCREW	2P+3F(BC)	2900-2003-0000		1
M035	GEAR	(WHEEL)	4154-5991-0		1
M036	WASHER	(B)	4154-4491-0		1
M037	SCREW	3TTB+8B	2854-3008-0000		1
M038	ROLLER	DVCP701	4154-6131-0		1
M039	ROULETTE	(HS)	4154-6023-1		1
M040	SCREW	SCREW	4135-3301-0		1
M050	ARM	--	4154-6051-0		1
M051	CUSHION	--	4157-0532-0		1
M052	RETAINER	--	4135-3881-0		1
M054	CUSHION	--	4157-0591-0		1



## EXPLODED VIEW OF MECHANISM/ PARTS LIST

CD DRIVE UNIT : KSM-213CCM

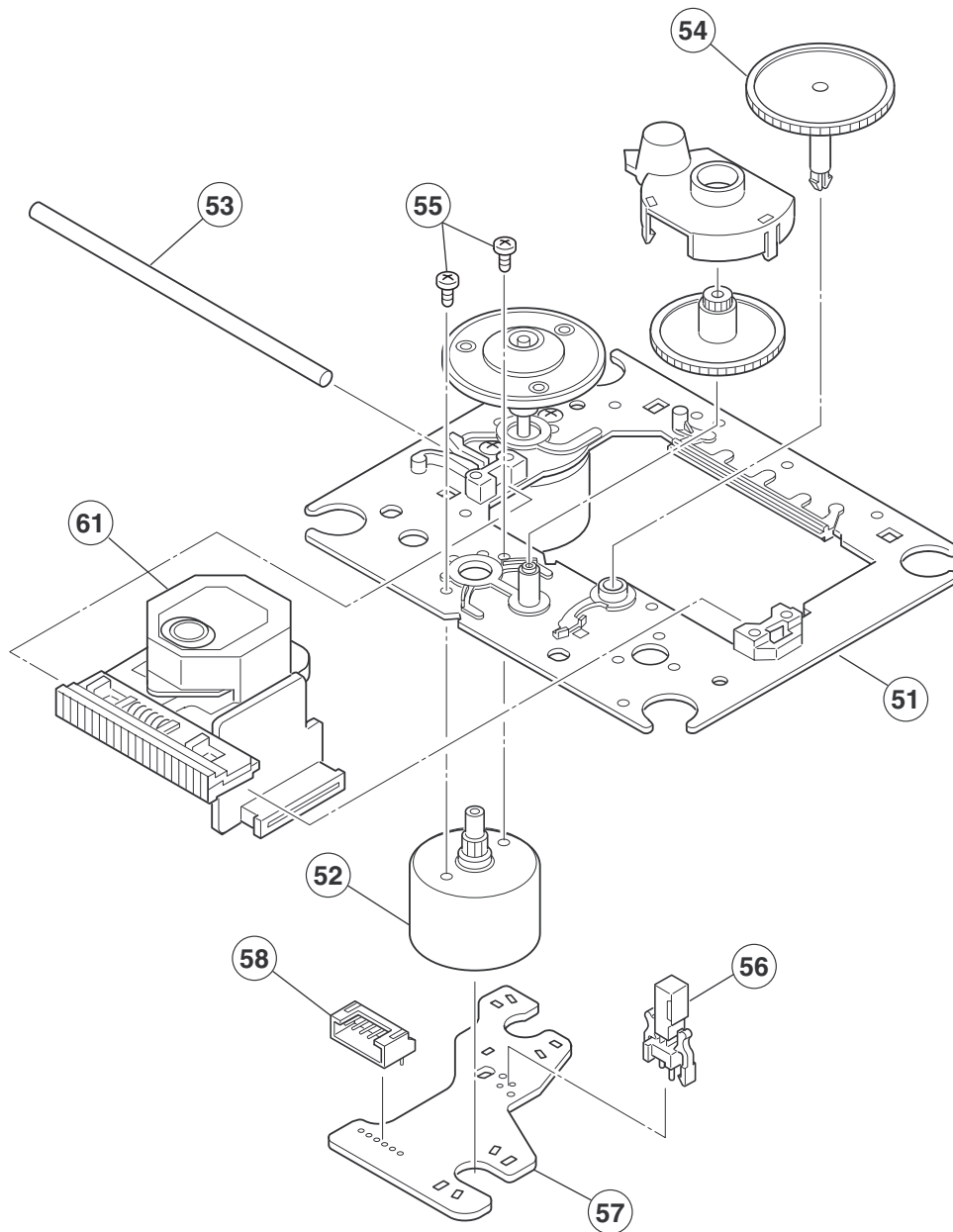

## PARTS LIST

REF. NO.	PART NO.	DESCRIPTION
51	X-2625-877-1	Motor chassis ass'y
52	X2625-769-1	Motor gear ass'y
53	2626-908-01	Sled shaft
54	24810023	Gear (A) (S)
55	7621-255-15	P2 x 3, Screw
56	24840008	Leaf switch
57	1639-678-12	Motor PC board
58	1-564-722-11	Connector 6pin
61	8848-483-05	KSS-213C, Pickup

A

B

C

D

# SCHEMATIC DIAGRAM-1

## U10 : MAIN CIRCUIT PC BOARD NADG-8053-1D

1

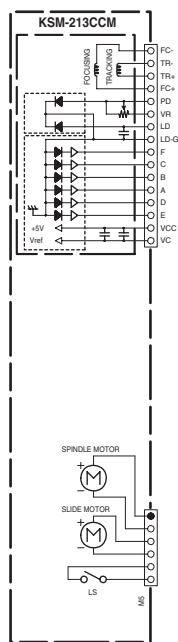

2

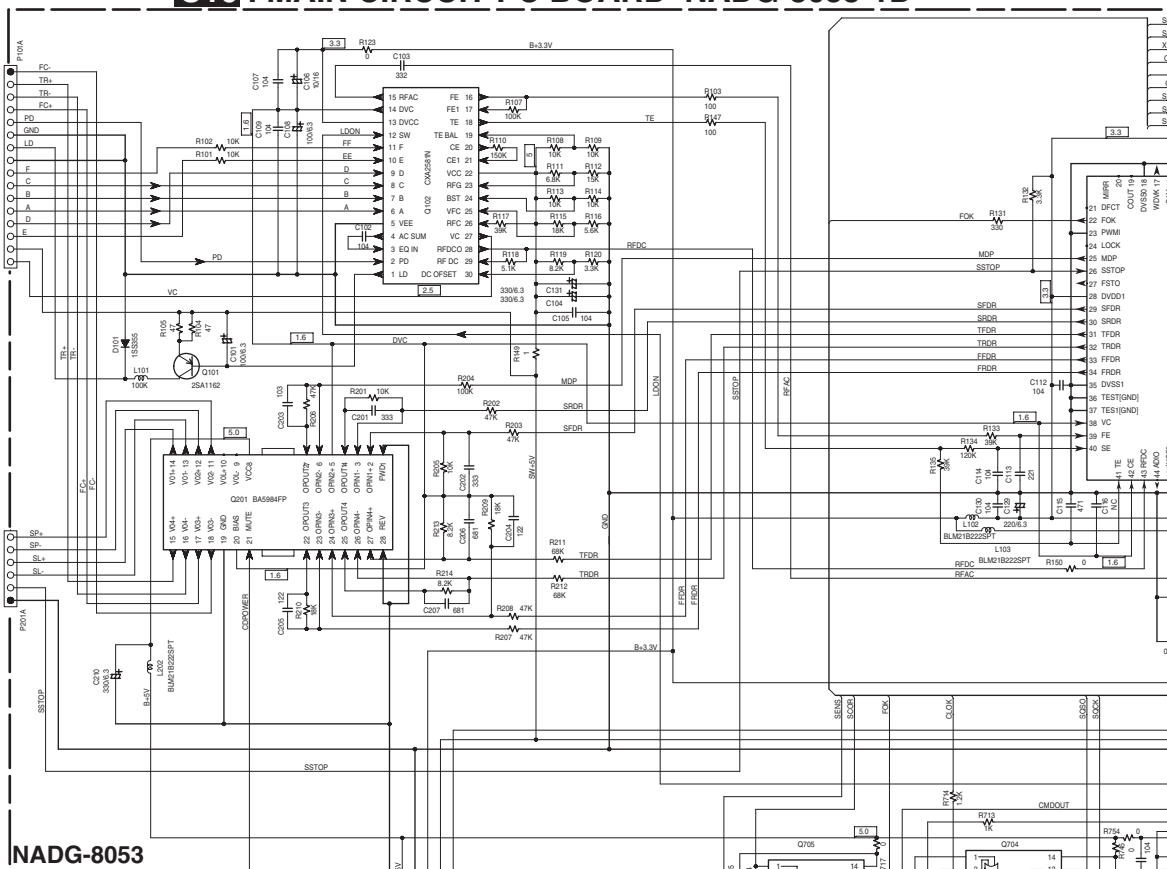

3

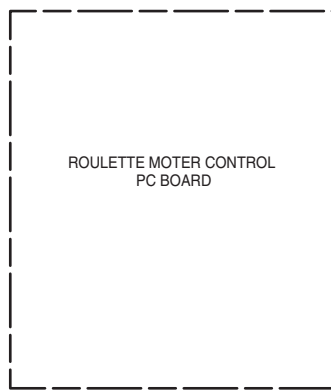

4



5

### U12-4 : POWER TRANSFORMER PC BOARD NAPS-8058-1D

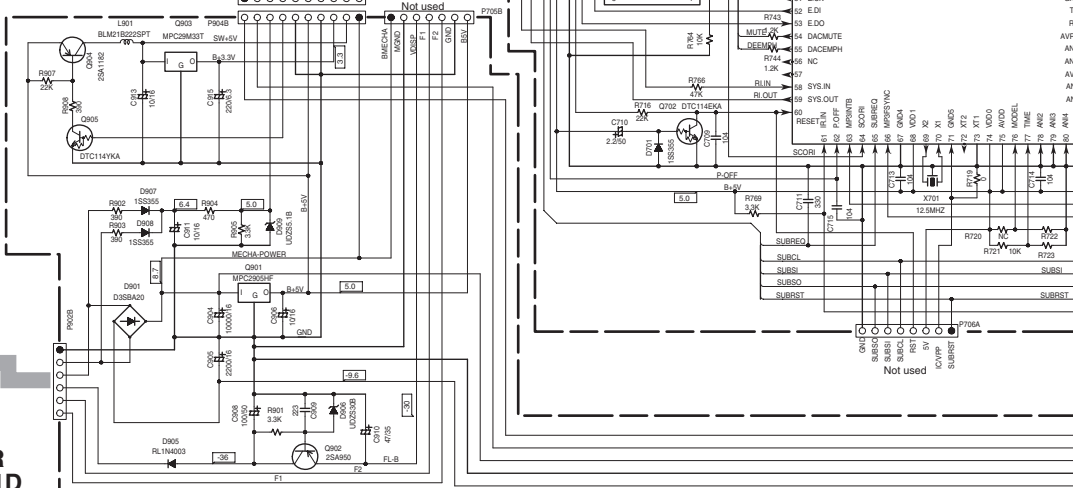

To AC Inlet terminal

U12-9: RS-232 TERMINAL PC BOARD NADG-8065-1D

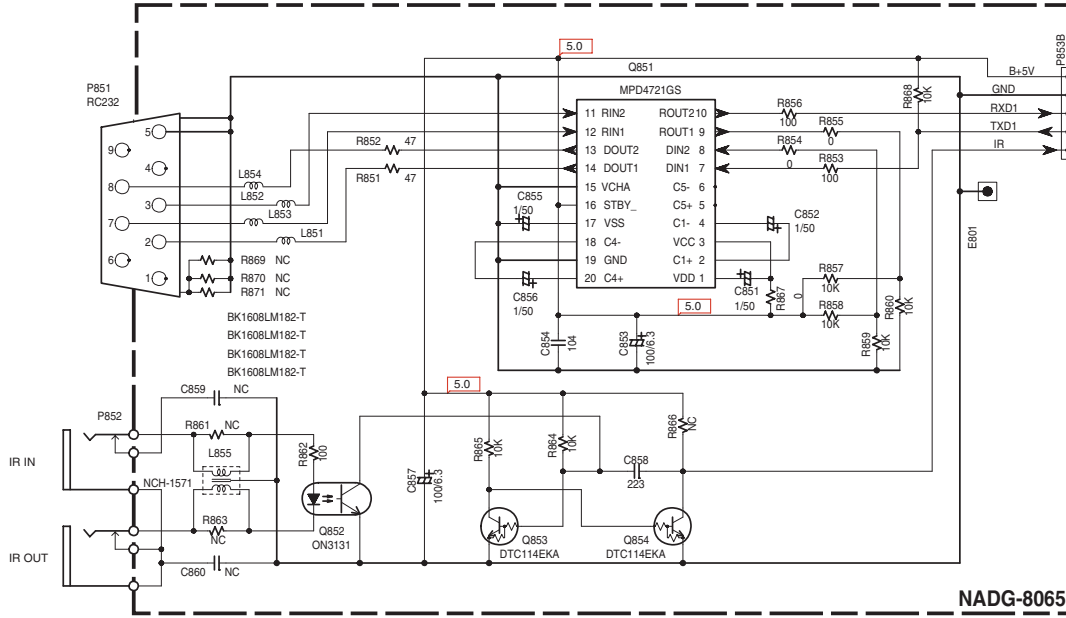

To Main circuit PC board NADG-8055

NADG-8065

U12-5: DISC SENSOR PC BOARD NAETC-8059-1D

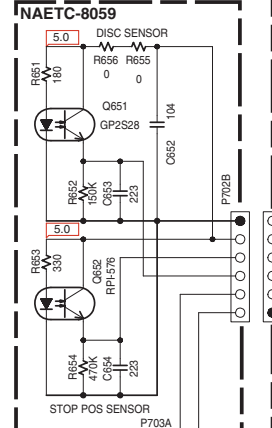

U12-6: ROULETTE MOTOR PCB NAETC-8060-1D

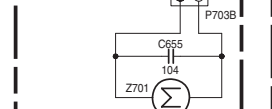

U12-7: LOADING MOTOR PCB NAETC-8061-1D

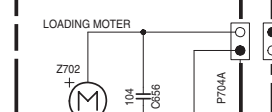

U12-8: CONNECTION PCB NAETD-C-8062-1D

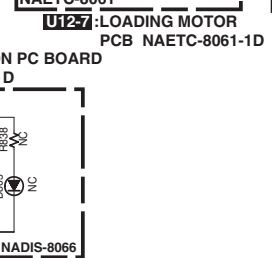

U12-3: MECHANISM CONTROL PC BOARD NAAR-8057-1D

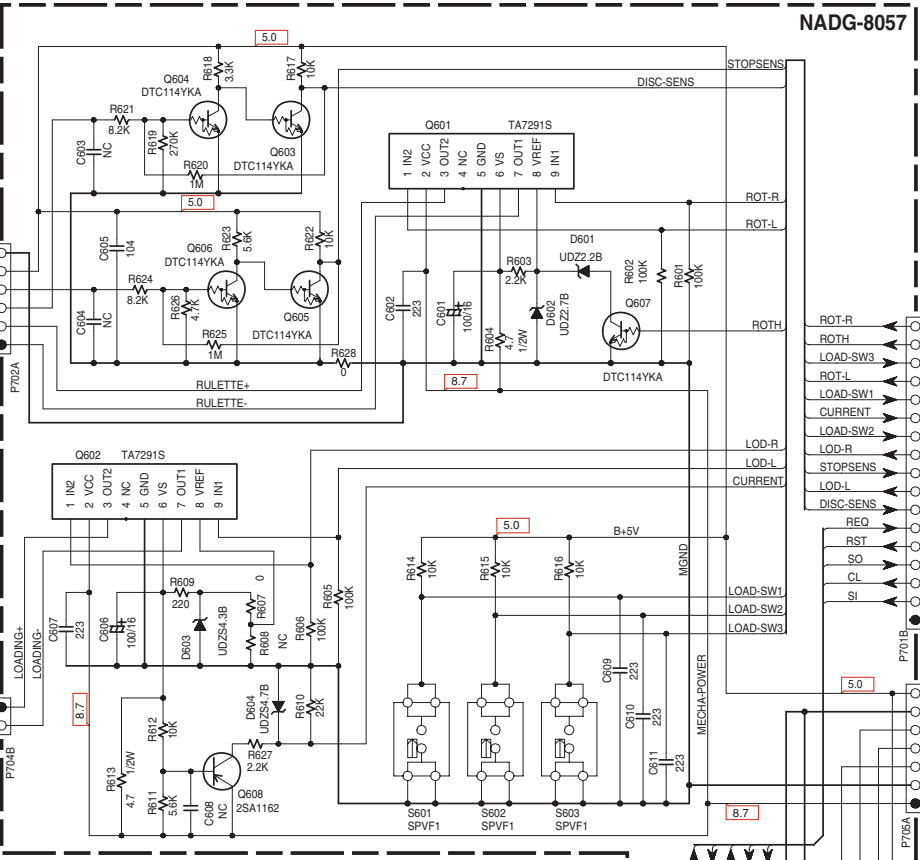

NADG-8057

To Main circuit PC board NADG-8055

To Output terminal PC Board NAAR-8056

MINIATION PC BOARD IS-8066-1D

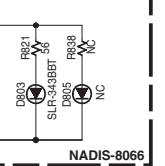

U12-8: CONNECTION PCB NAETD-C-8062-1D



A B C D E F G H  
SCHEMATIC DIAGRAM-1 U10: MAIN CIRCUIT PC BOARD NADG-8053-1D U12-2: OUTPUT TERMINAL PC BOARD NAAR-8056-1D

1

2

3

4

5

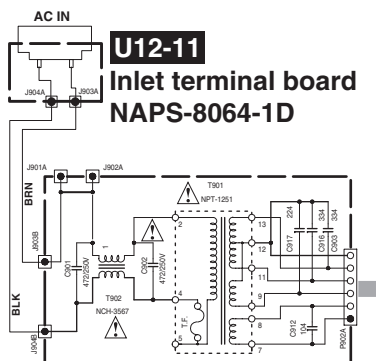
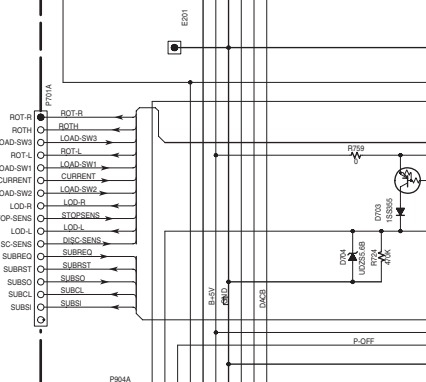
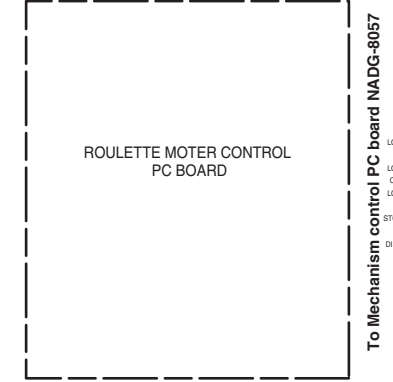
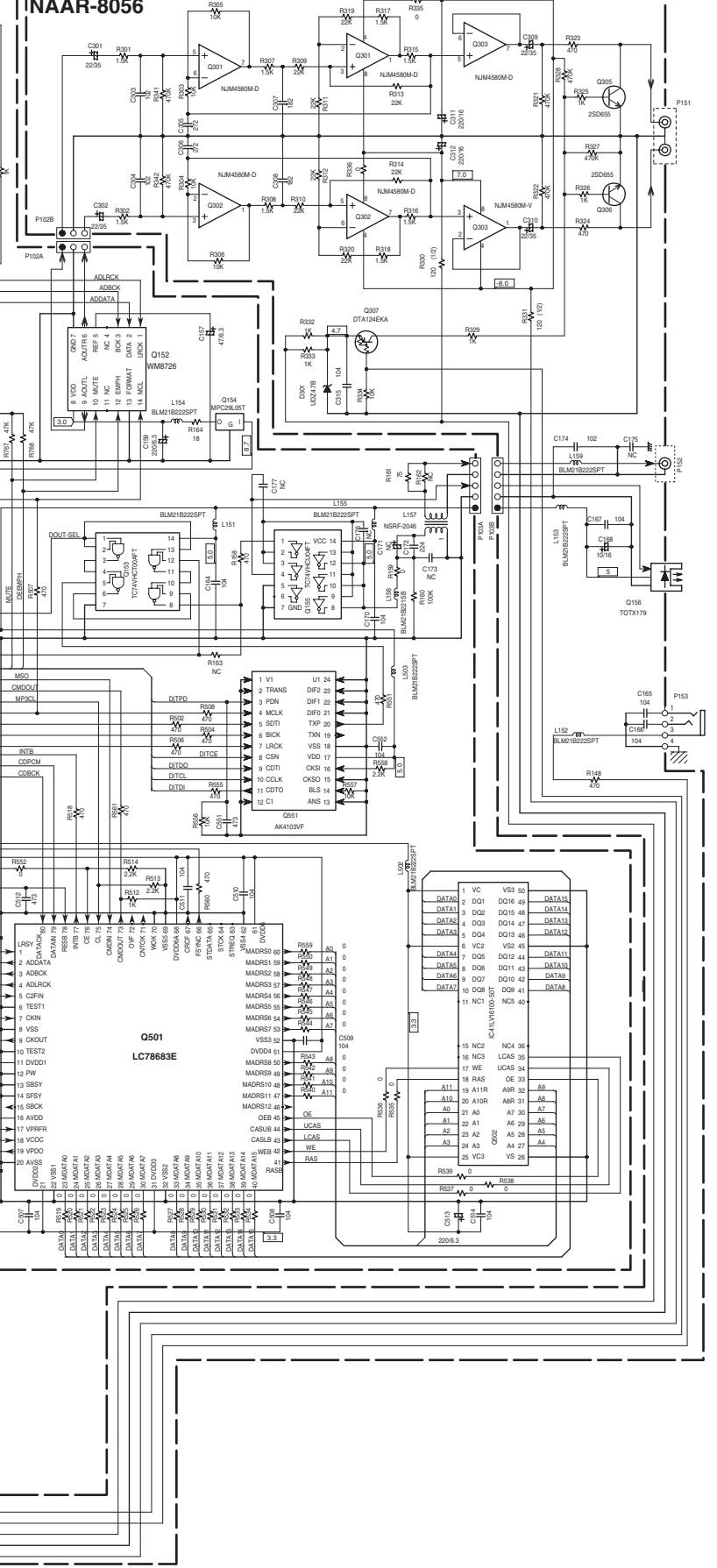
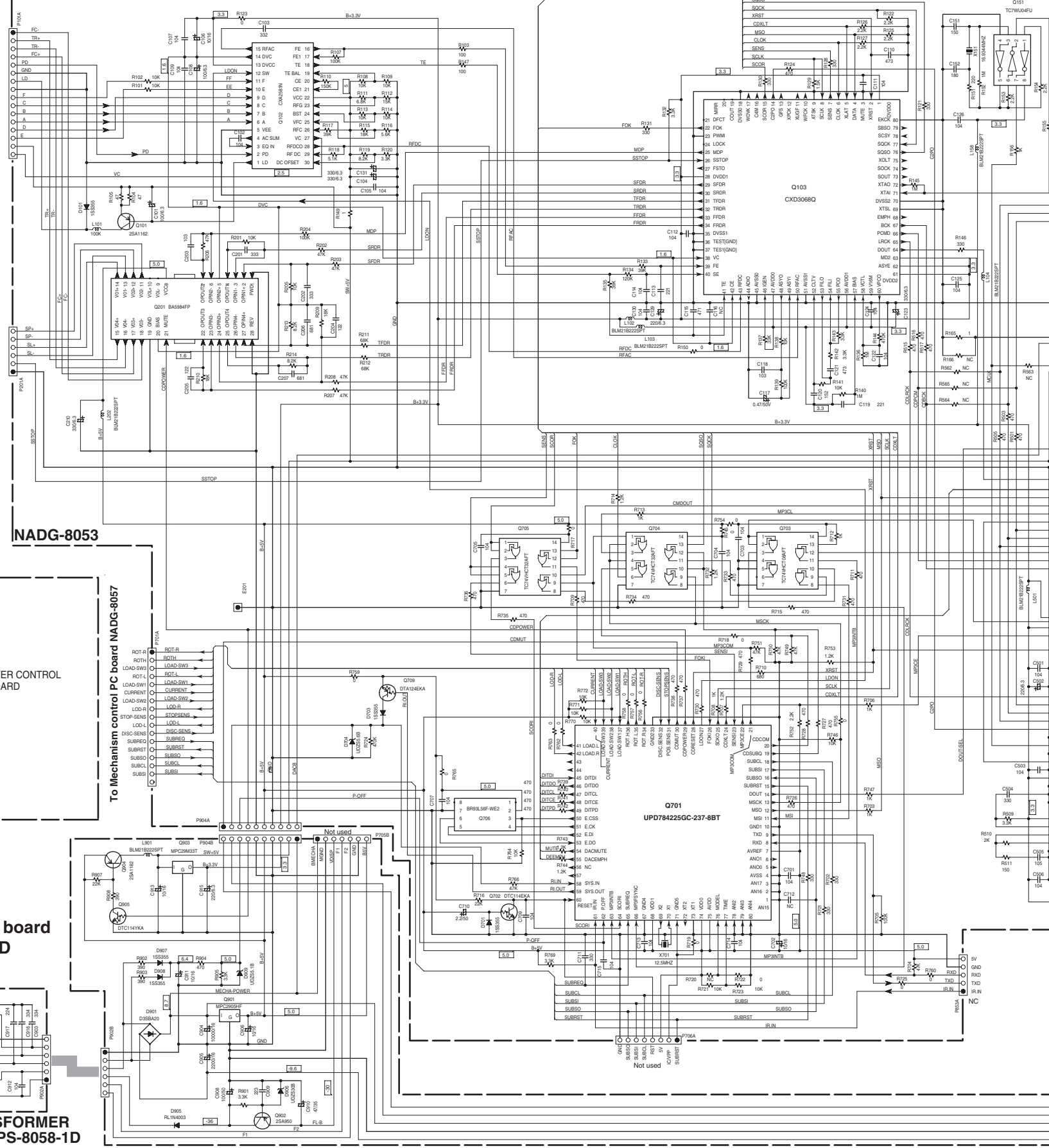
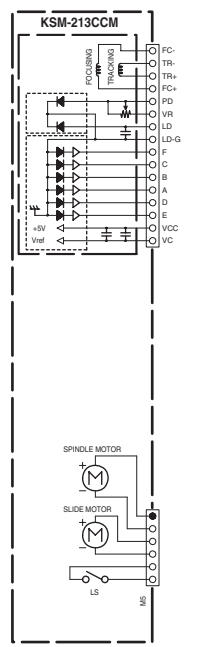

A B C D E F G H

SCHEMATIC DIAGRAM-2

U12-0: DISPLAY CIRCUIT PC BOARD NADIS-8054-1D

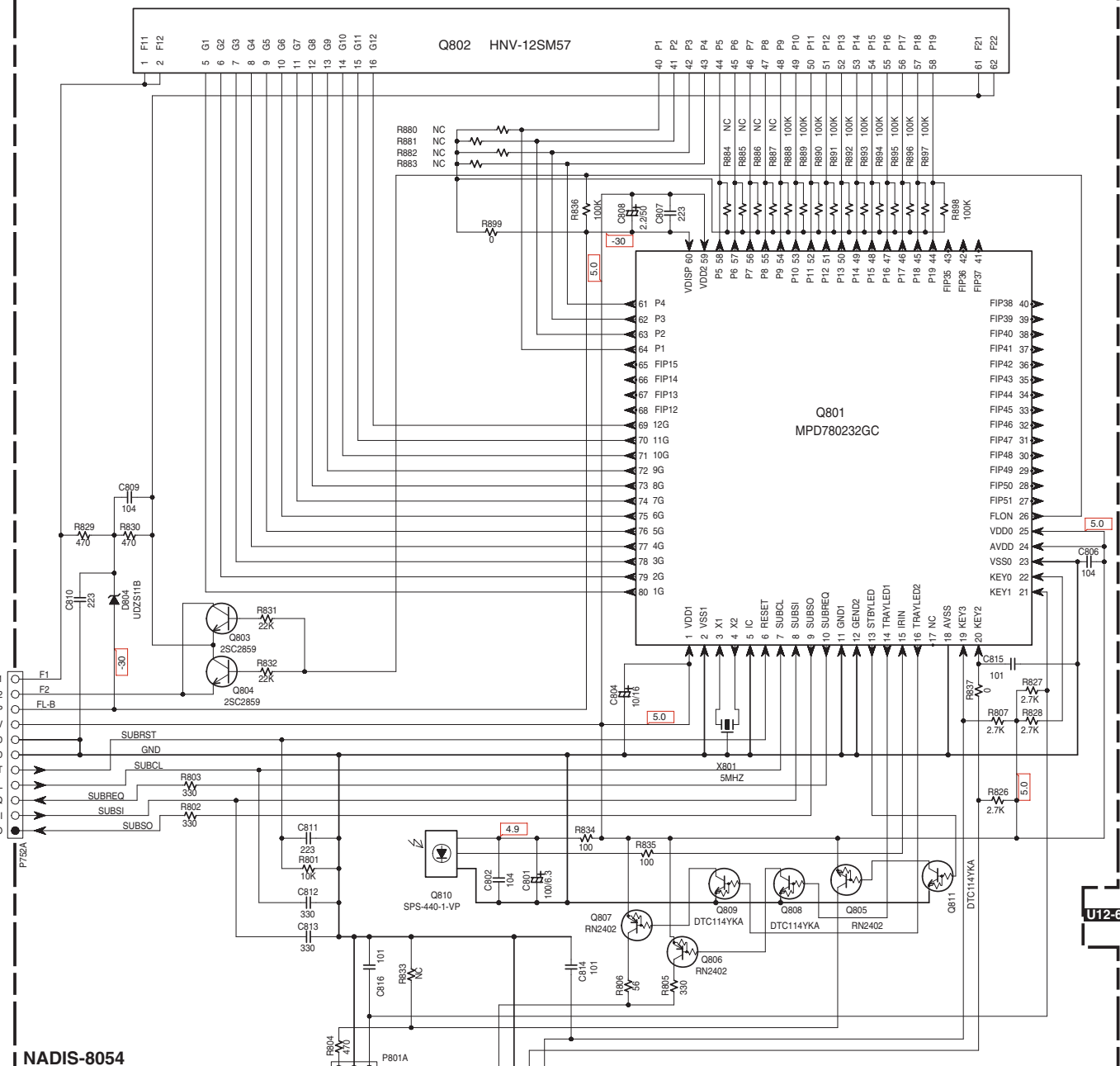

NADIS-8054

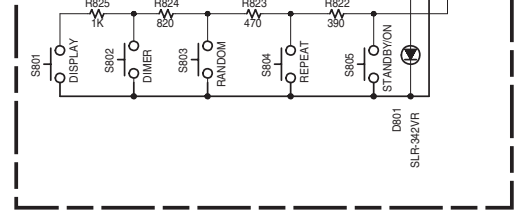

U12-1: STANDBY LED PC BOARD NASW-8055-1D

U12-9: RS-232 TERMINAL PC BOARD NADG-8065-1D

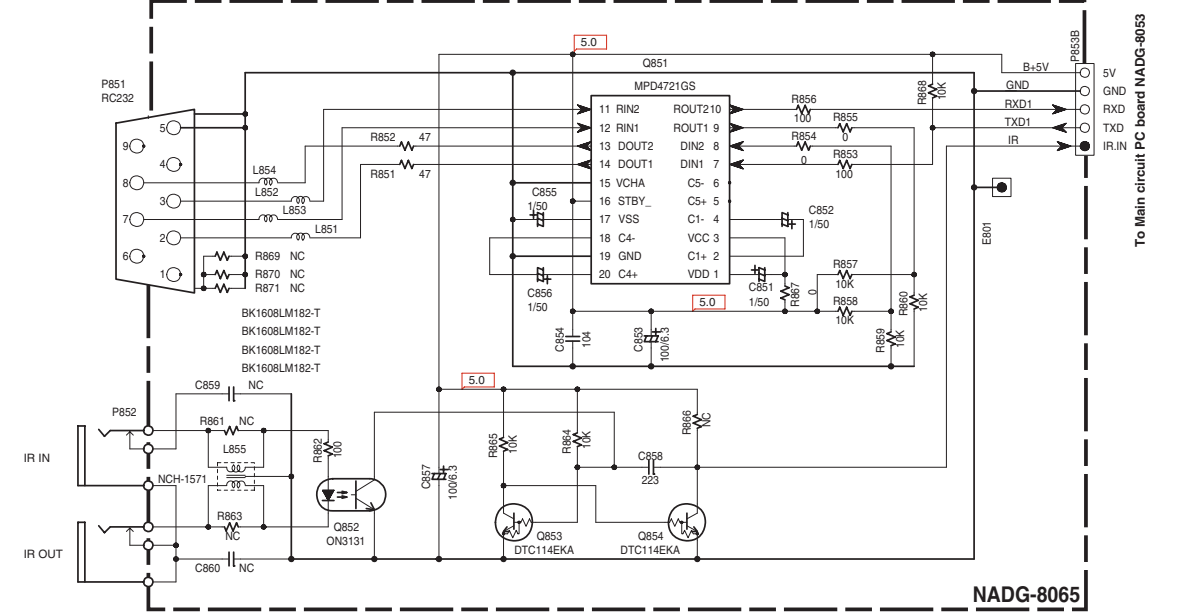

NADG-8065

U12-5: DISC SENSOR PC BOARD NAETC-8059-1D

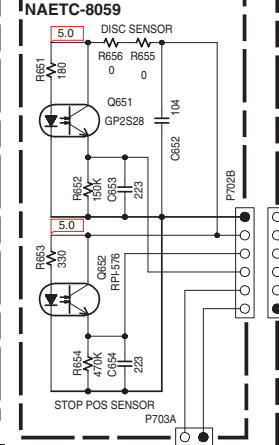

U12-6: ROULETTE MOTOR PCB NAETC-8060-1D

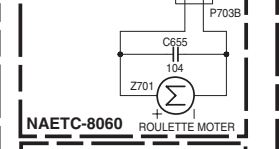

U12-7: LOADING MOTOR PCB NAETC-8061-1D

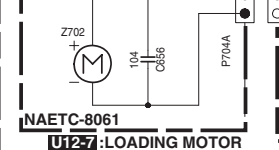

U12-10: ILLUMINATION PC BOARD NADIS-8066-1D

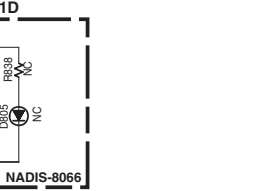

NADIS-8066

U12-3: MECHANISM CONTROL PC BOARD NAAR-8057-1D



U12-3: CONNECTION PCB NAETD-C-8062-1D

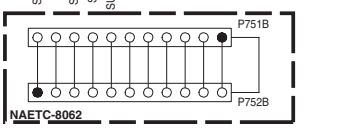

NAETC-8062

1

2

3

4

5

To CONNECTION PC BOARD NAETC-8062

To Main circuit PC board NADG-8065

To Main circuit PC board NADG-8057

To Output terminal PC Board NAAR-8056





# PC BOARD CONNECTION DIAGRAM

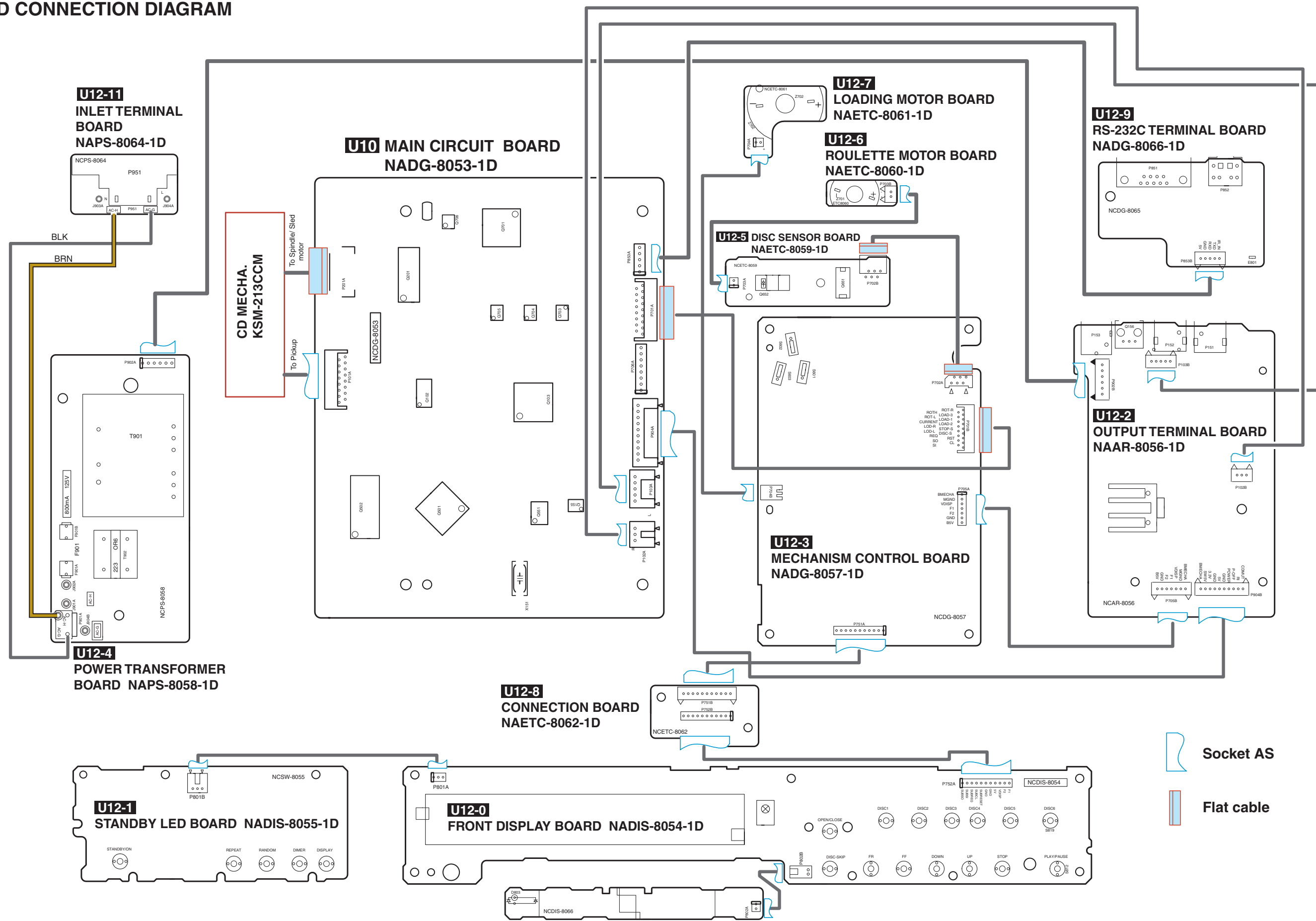

# PRINTED CIRCUIT BOARD VIEW-1

## U10 : MAIN CIRCUIT PC BOARD NADG-8053-1D

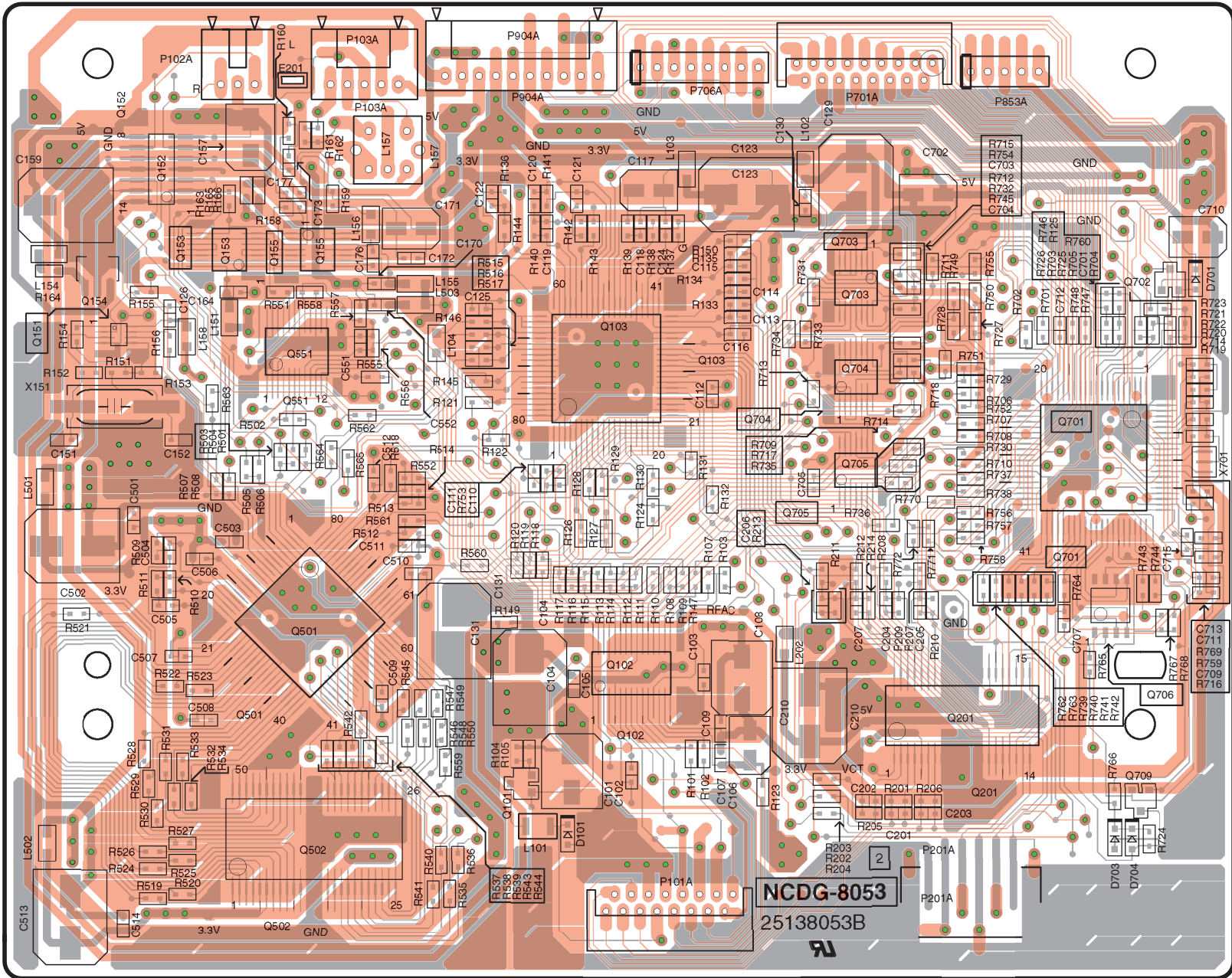

■ : Top pattern    ■ : Bottom pattern

# PRINTED CIRCUIT BOARD VIEW FROM SOLDERING SIDE-2

## **U12-0:** FRONT DISPLAY CIRCUIT PC BOARD NADIS-8054-1D

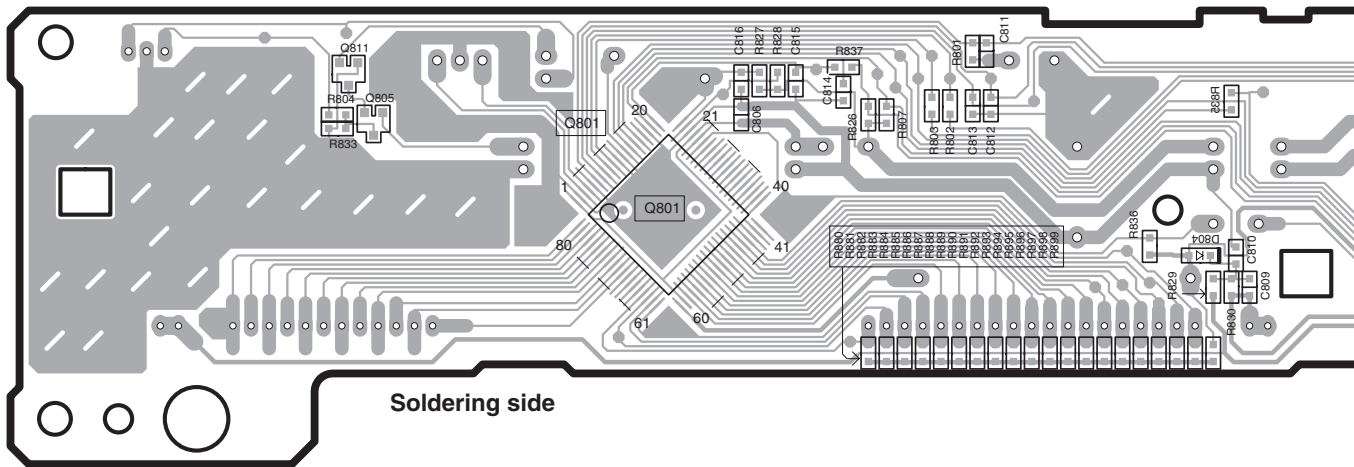
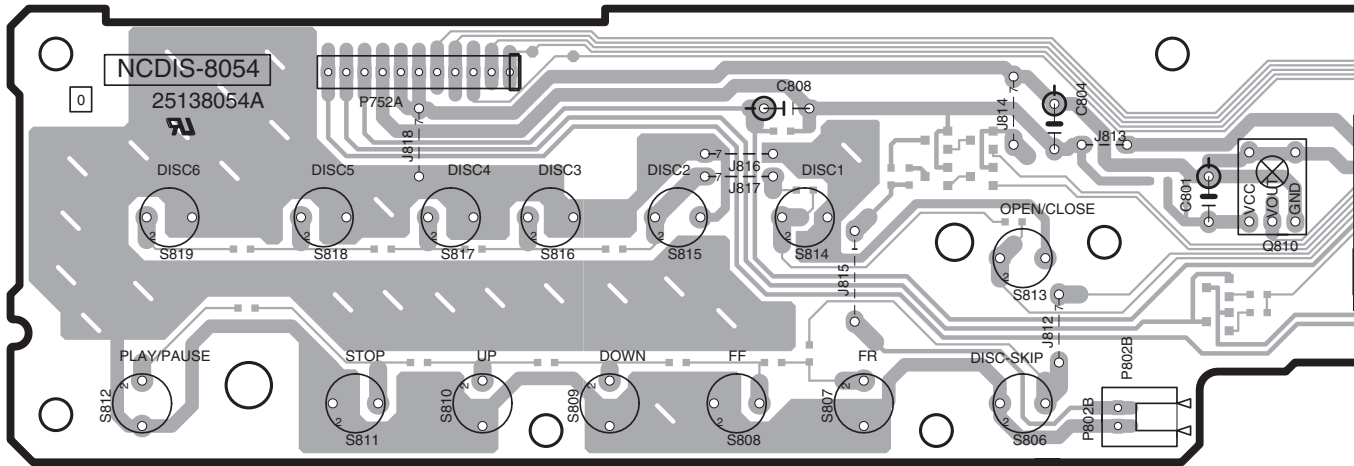

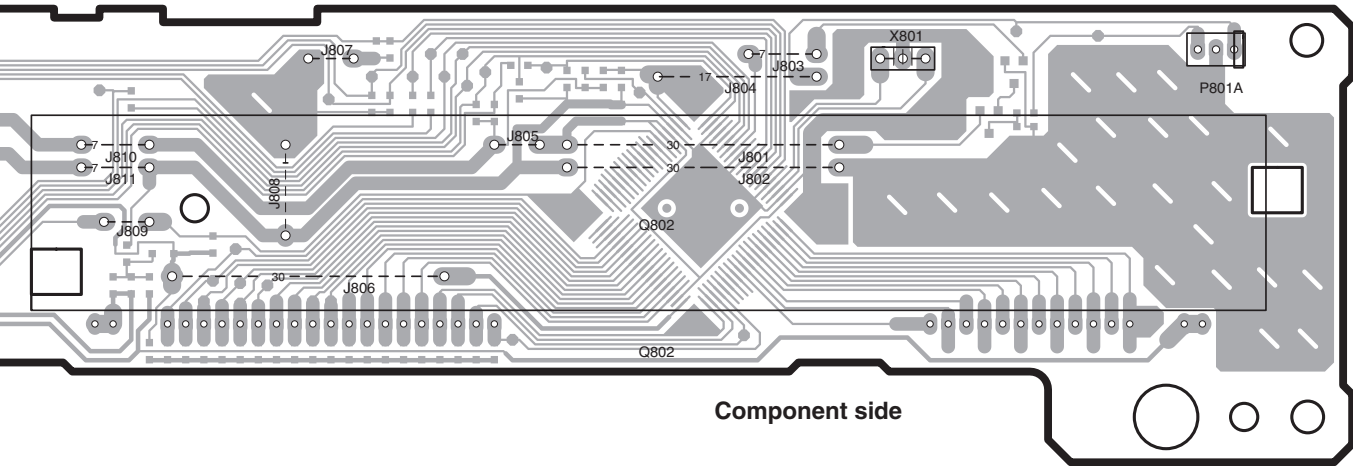

Component side

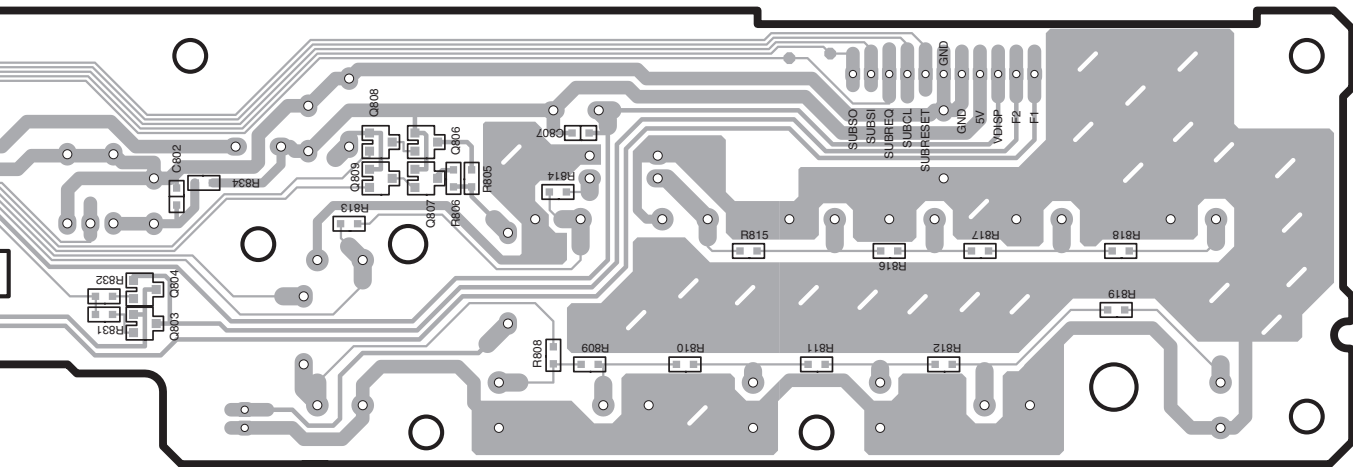

# PRINTED CIRCUIT BOARD VIEW FROM SOLDERING SIDE-3

## U12-3 : MECHANISM CONTROL PC BOARD NADG-8057-1D

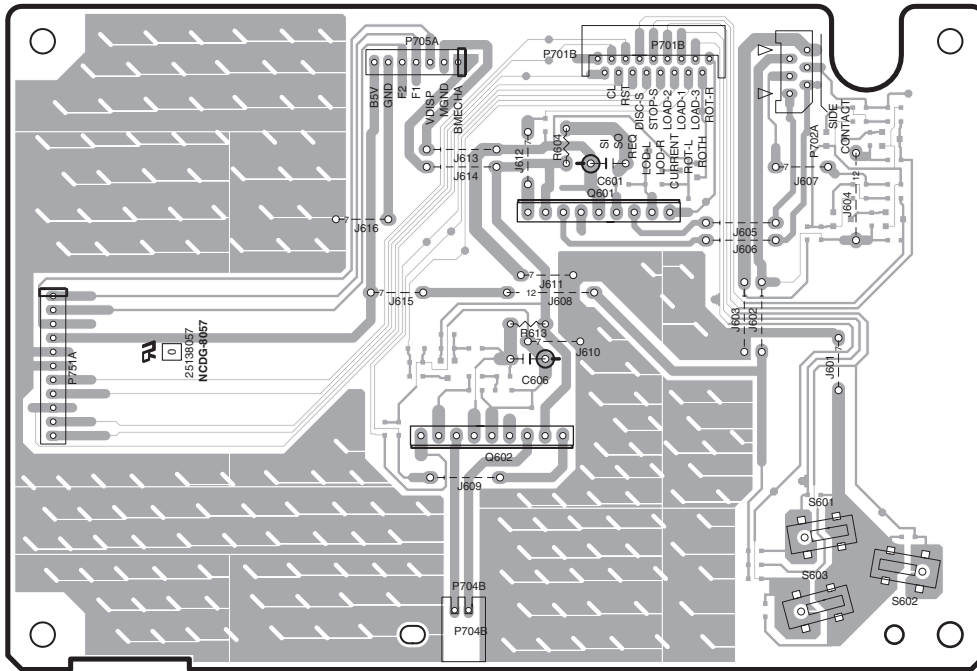

Component side

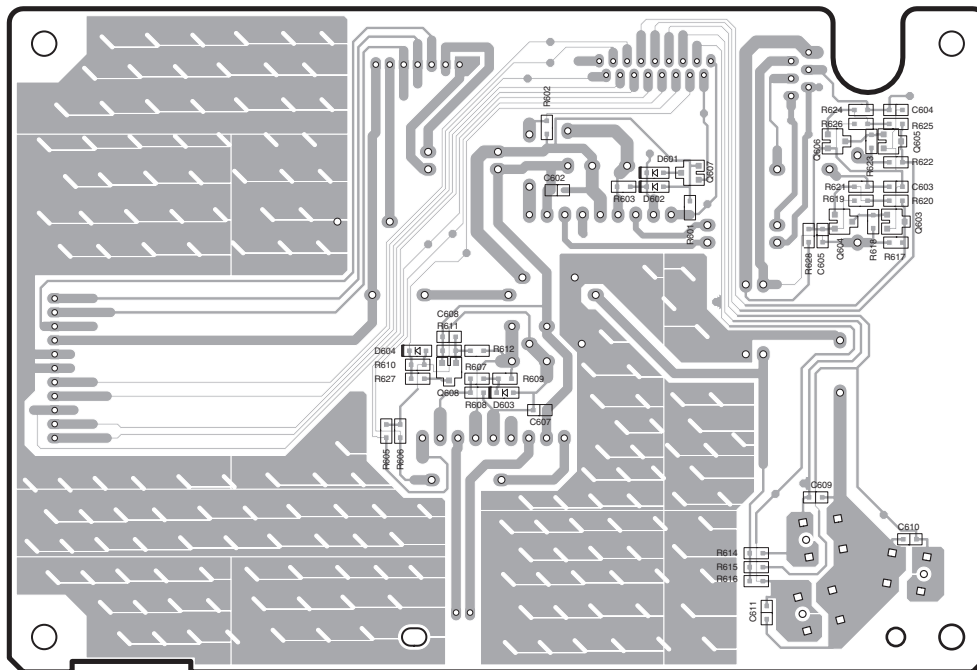

Soldering side

PRINTED CIRCUIT BOARD VIEW FROM SOLDERING SIDE-4

**U12-9** : RS-232C TERMINAL PC BOARD  
NADG-8065-1D

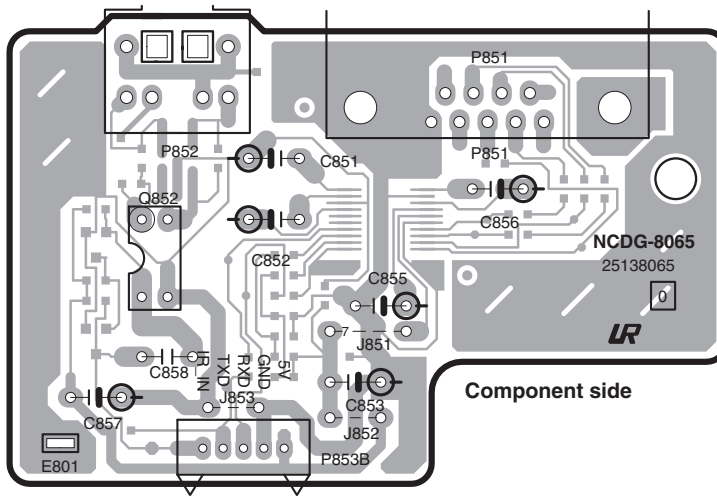

Component side

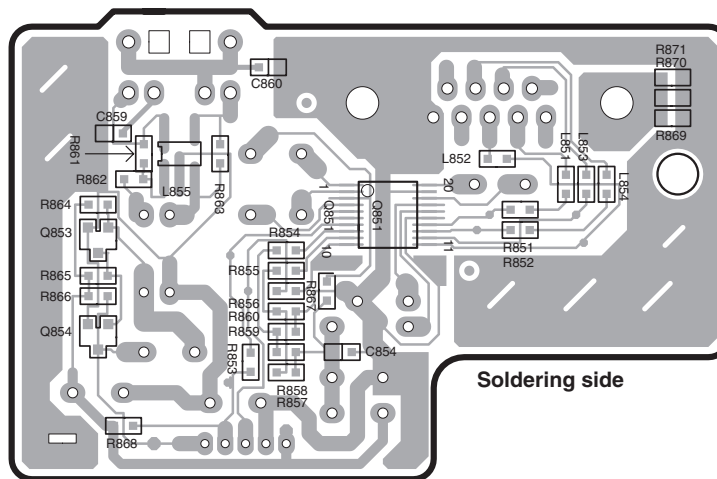

Soldering side

**U12-11** : OUTLET TERMINAL PC BOARD  
NAPS-8064-1D

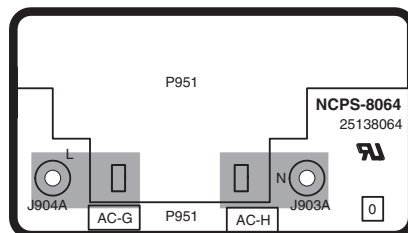

Component side



PRINTED CIRCUIT BOARD VIEW FROM SOLDERING SIDE-6

**U12-6** : ROULETTE MOTOR PC BOARD NAETC-8060-1D

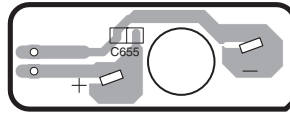
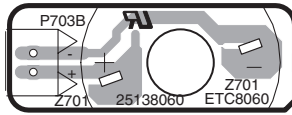

**U12-7** : LOADING MOTOR PC BOARD NAETC-8061-1D

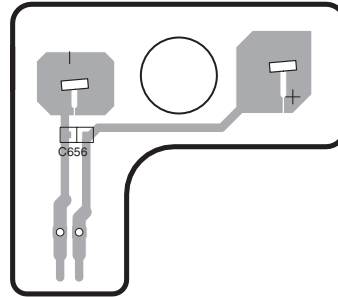
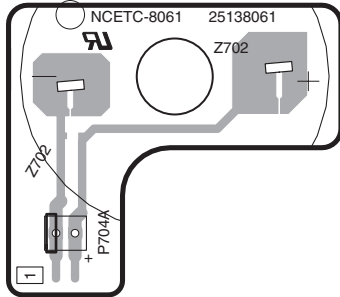

**U12-8** : CONNECTION PC BOARD  
NAETC-8062-1D

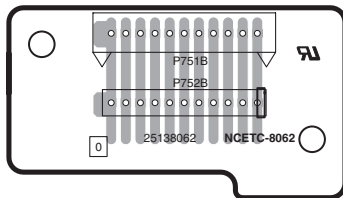

PRINTED CIRCUIT BOARD VIEW FROM SOLDERING SIDE-5

**U12-4: POWER TRANSFORMER PC BOARD NAPS-8058-1D**

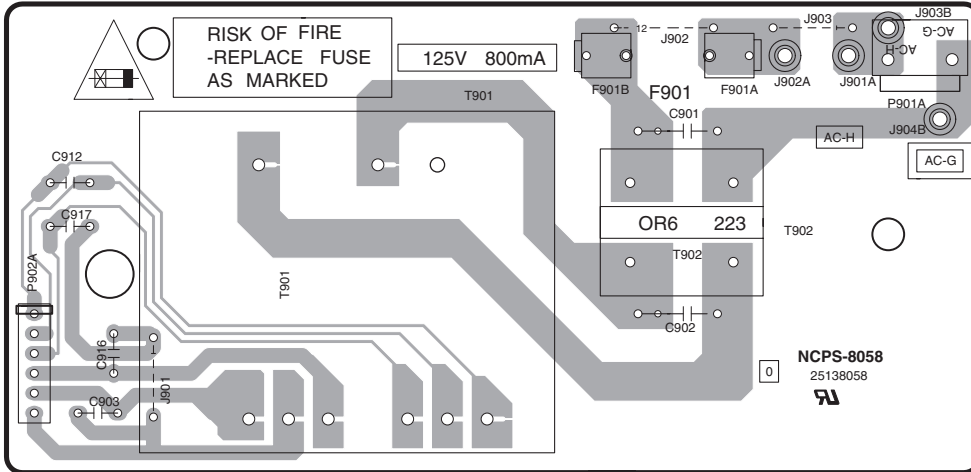

**U12-5: DISC SENSOR PC BOARD NAETC-8059-1D**

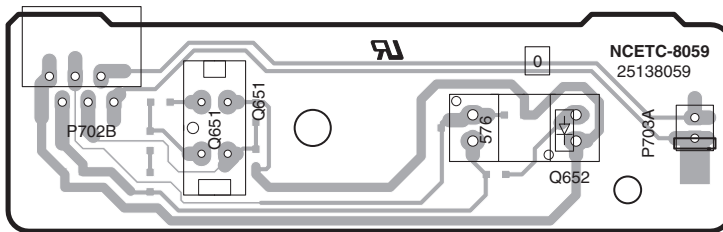

Component side

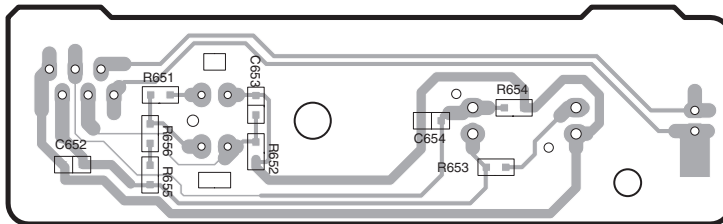

Soldering side

## PRINTED CIRCUIT VIEW FROM SOLDERING SIDE-6

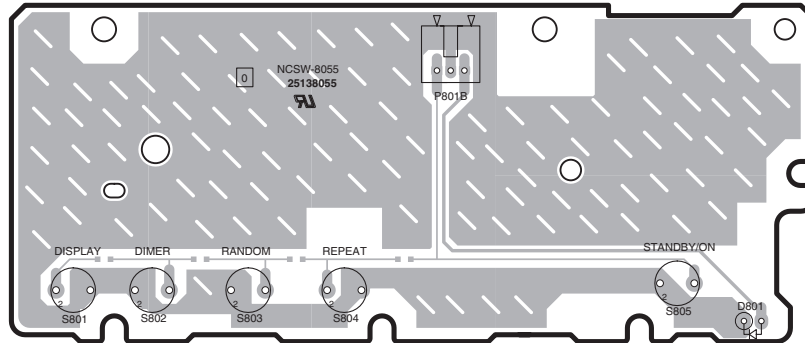
**U12-1: STANDBY LED PC BOARD NASW-8055-1D**

Component side

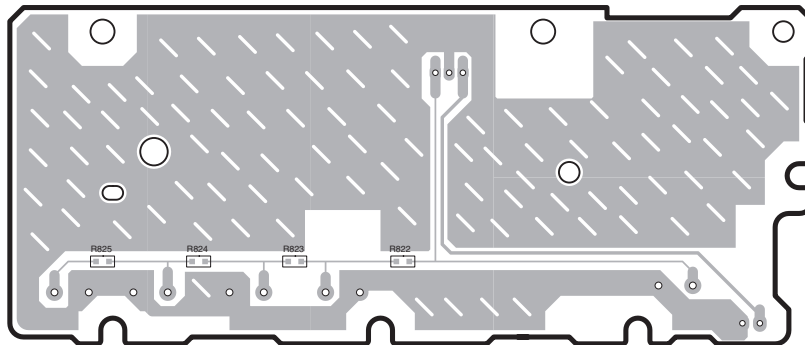

Soldering side

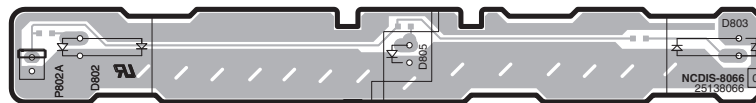
**U12-10: ILLUMINATION PC BOARD NADIS-8066-1D**

Component side

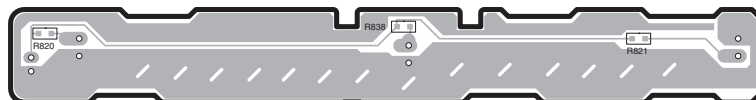

Soldering side

**PRINTED CIRCUIT VIEW FROM SOLDERING SIDE-7**

**U12-2 : OUTPUT TERMINAL PC BOARD NAAR-8056-1D**

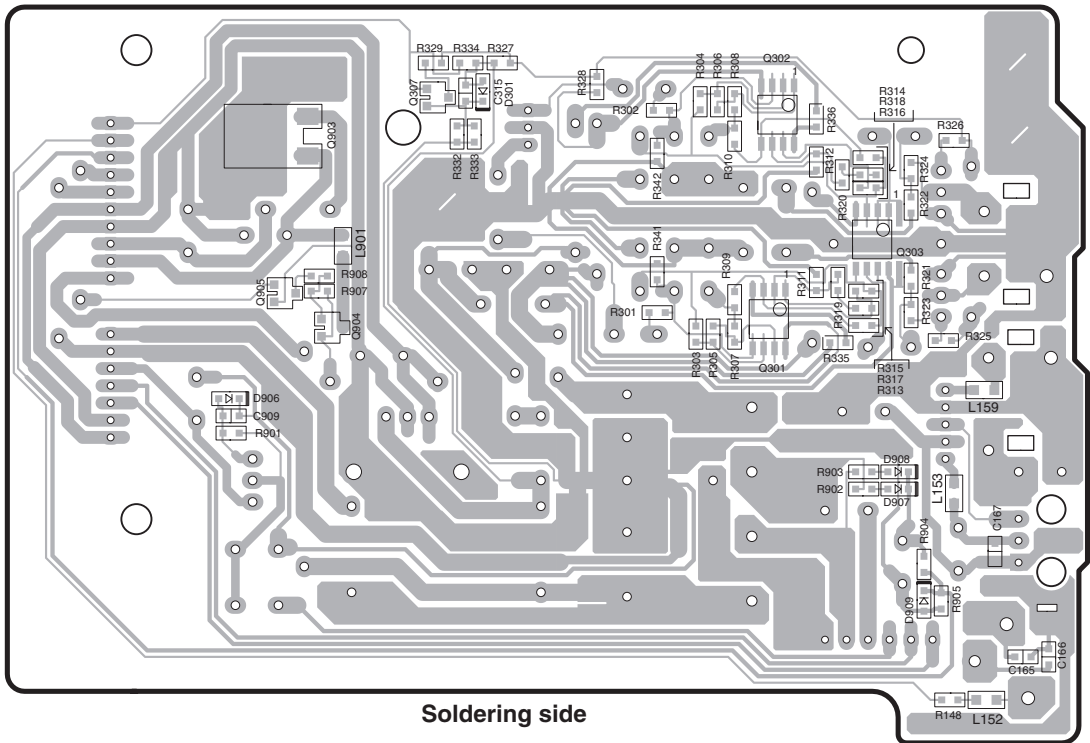
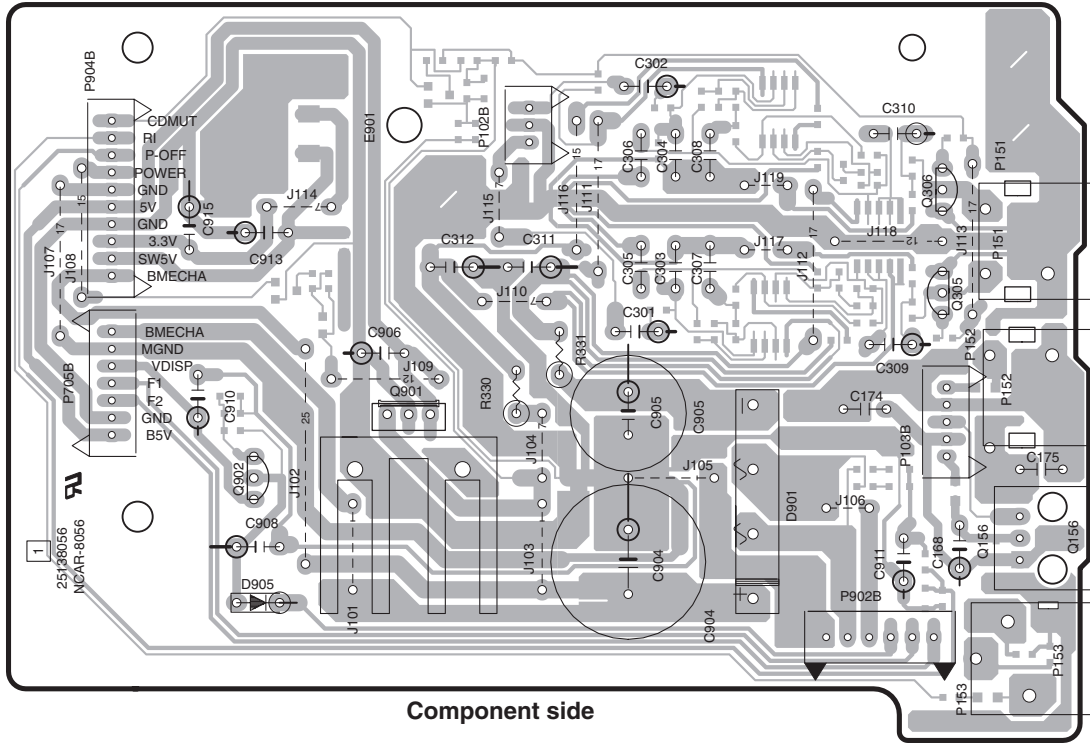

PRINTED CIRCUIT BOARD VIEW FROM SOLDERING SIDE-2

**U12-0:** FRONT DISPLAY CIRCUIT PC BOARD NADIS-8054-1D

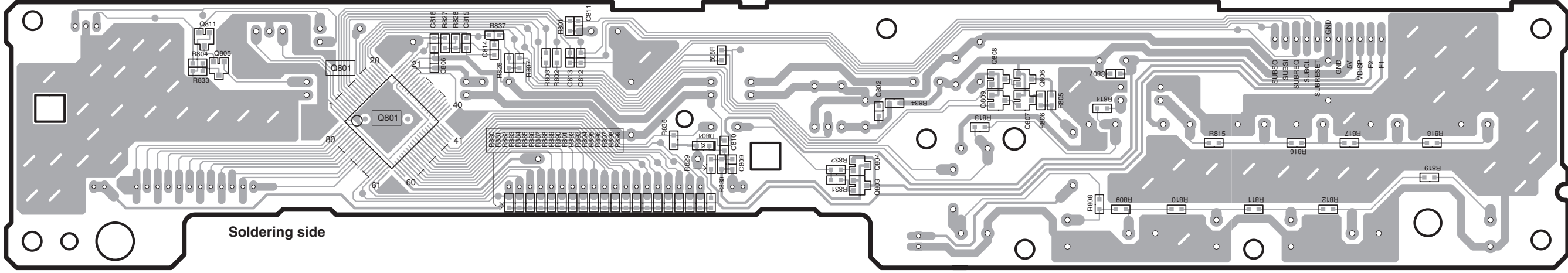
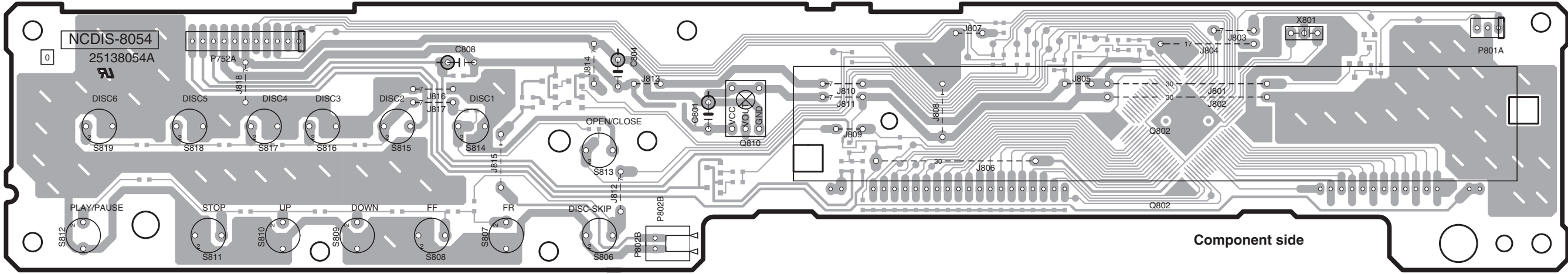

# IC BLOCK DIAGRAM/TERMINAL DESCRIPTION

## Q551 : AK4103VF DIGITAL AUDIO TRANSMITTER

### PIN LAYOUT

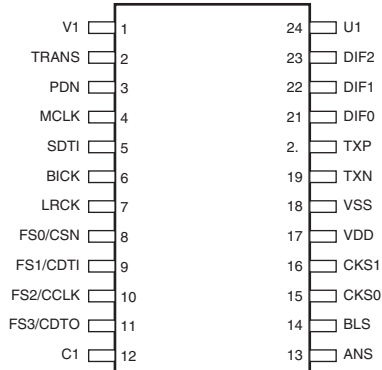

### BLOCK DIAGRAM

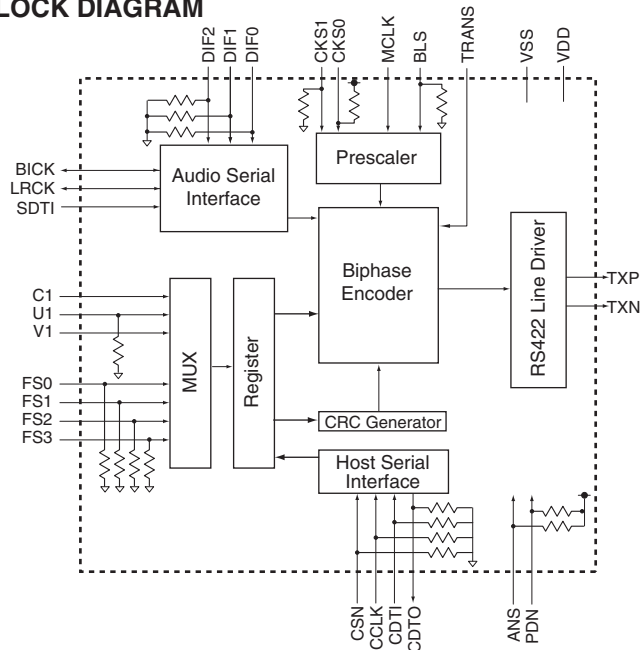

### PIN / FUNCTION

No.	PIN NAME	I/O	DESCRIPTION
1	V1	I	Validity bit input pin
2	TRANS	I	Audio routing mode (transparent mode) pin at synchronous mode. 0: Normal mode, 1: Audio routing mode
3	PDN	I	Power down & reset pin. When "L", the AK4103 is powered-
4	MCLK	I	Master clock input pin.
5	SDTI	I	Audio serial data input pin.
6	BICK	I/O	Audio serial data clock input/ output pin.
7	LRCK	I/O	Input output channel clock pin.
8	FS0	I	Sampling frequency select 0 pin at synchronous mode.
	CSN	I	Host interface chip select pin at asynchronous mode.
	AKMODE	I	AK4112A: mode pin at audio routing mode.
9	FS1	I	Sampling frequency select 1 pin at synchronous mode.
	CDTI	I	Host interface data input pin at asynchronous mode.
10	FS2	I	Sampling frequency select 2 pin at synchronous mode.
	CCLK	I	Host interface bit clock input pin at asynchronous mode.
11	FS3	I	Sampling frequency select 3 pin.
	CDTI	O	Host interface data output pin.
12	C1	I	Channel status bit input pin.
13	ANS	I	Asynchronous/synchronous mode select pin. 1: synchronous
14	BLS	I/O	Block start input/output pin.
15	CKS0	I	Clock mode select 0 pin.
16	CKS1	I	Clock mode select 1 pin.
17	VDD	-	power supply pin. 4.75 to 5.25V
18	VSS	-	Ground pin.
19	TXN	O	Negative differential output pin.
20	TXP	O	Positive differential output pin.
21	DIF0	I	Audio serial input select 0 pin.
22	DIF1	I	Audio serial input select 1 pin.
23	DIF2	I	Audio serial input select 2 pin.
24	U1	I	User data bit input for channel 1.



## IC BLOCK DIAGRAM/TERMINAL DESCRIPTION

Q706 : BR93L56F-WE2 128 x 16 bit Electrically Programmable ROM (-1)

### PIN CONFIGURATIONS

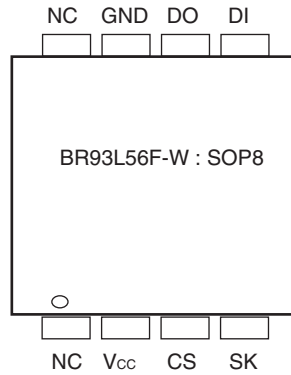

### TERMINAL FUNCTION

Terminal	IN/OUT	Function
Vcc	-	Power Supply
GND	-	Ground (0V)
CS	INPUT	Chip Select Control
SK	INPUT	Serial Data Clock Input
DI	INPUT	Start Bit, Op. code, Address, Serial Data Input
DO	OUTPUT	Serial Data Output, Ready/Busy Status Output
NC	-	No Connection (Vcc or GND or Open)

# IC BLOCK DIAGRAM/TERMINAL DESCRIPTION

Q706 : BR93L56F-WE2 128 x 16 bit Electrically Programmable ROM (-2)

## BLOCK DIAGRAM

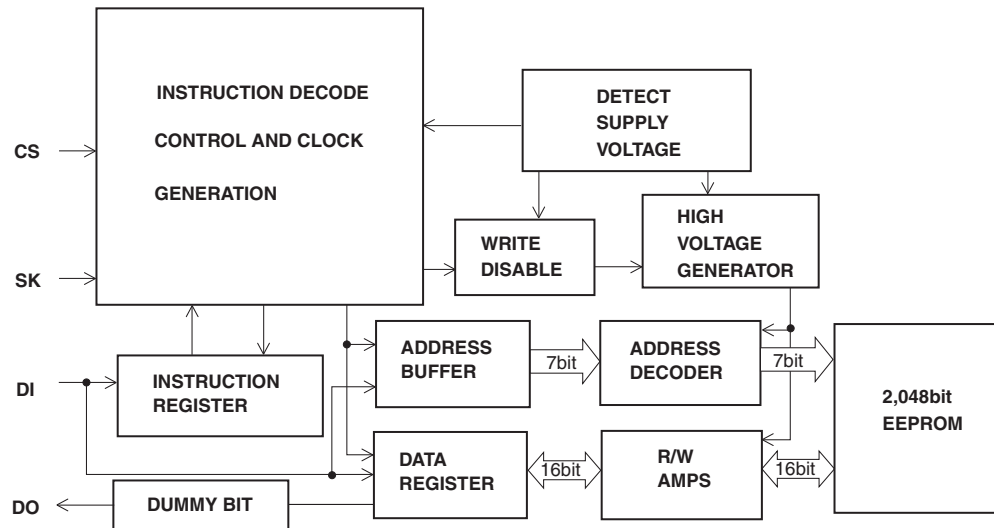

# IC BLOCK DIAGRAM/ TERMINAL DESCRIPTION

## Q502: IC41LV16100-50T 16M BIT DYNAMIC RAM

### PIN CONFIGURATION

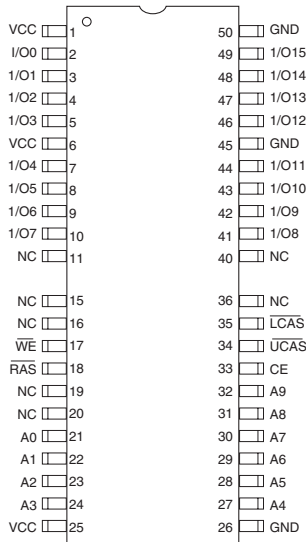

### PIN DESCRIPTION

- A0-A9 Address input
- I/O0-15 Data inputs/outputs
- WE Write enable
- OE Output enable
- RAS Row address strobe
- UCAS Upper column address strobe
- LCAS Lower column address strobe
- VCC Power
- GND Ground
- NC No connection

### FUNCTIONAL BLOCK DIAGRAM

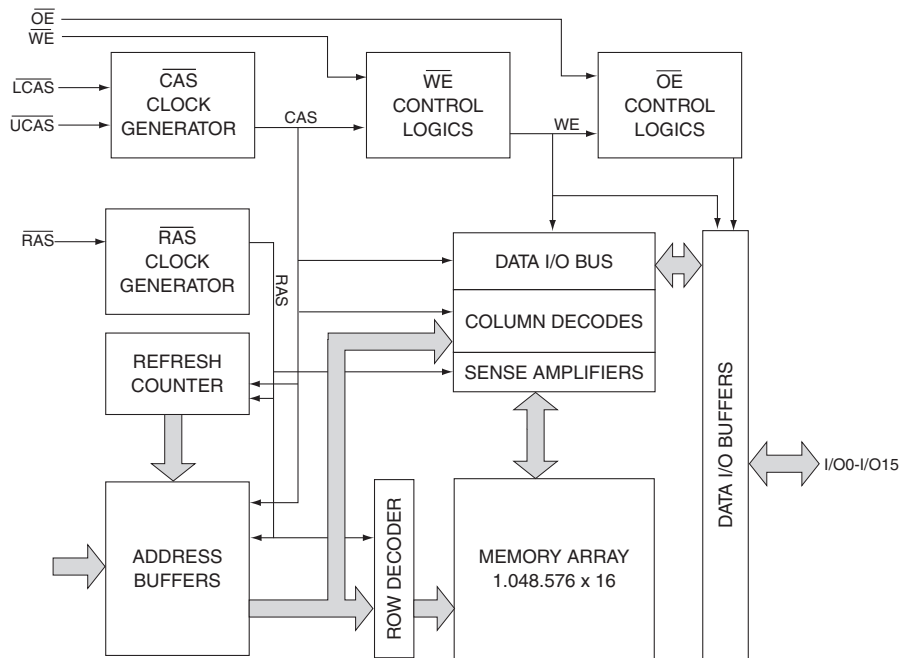

### TRUTH TABLE

Function	RAS	LCAS	UCAS	WE	OE	Address tr/tc	I/O	
Standby	H	H	H	X	X	X	High-Z	
Read: Word	L	L	L	H	L	ROW/COL	Dout	
Read: Lower Byte	L	L	H	H	L	ROW/COL	Lower Byte. Dout Upper Byte, High-Z	
Read: Upper Byte	L	H	L	H	L	ROW/COL	Lower Byte, High-Z Upper Byte. Dout	
Write: Word (Early Write)	L	L	L	L	X	ROW/COL	Din	
Write: Lower Byte (Early Write)	L	L	H	L	X	ROW/COL	Lower Byte. Din Upper Byte, High-Z	
Write: Upper Byte (Early Write)	L	H	L	L	X	ROW/COL	Lower Byte, High-Z Upper Byte. Din	
Read Write	L	L	L	H-L	H-L	ROW/COL	Dout, Din	
EDO Page-Mode Read	1st Cycle	L	H-L	H-L	H	L	ROW/COL	Dout
	2nd Cycle	L	H-L	H-L	H	L	NA/COL	Dout
	Any Cycle	L	L-H	L-H	H	L	NA/NA	Dout
EDO Page-Mode Read	1st Cycle	L	H-L	H-L	L	X	ROW/COL	Din
	2nd Cycle	L	H-L	H-L	L	X	NA/COL	Din
EDO Page-Mode Read-Write	1st Cycle	L	H-L	H-L	H-L	L	ROW/COL	Dout, Din
	2nd Cycle	L	H-L	H-L	H-L	L-H	NA/COL	Dout, Din
Hidden Refresh	1st Cycle	L-H-L	L	L	-H	L	ROW/COL	Dout
	2nd Cycle	L-H-L	L	L	L	X	ROW/COL	Dout
RAS-Only Refresh	L	H	H	X	X	ROW/NA	High-Z	
CBR Refresh	H-L	L	L	X	X	X	High-Z	

# IC BLOCK DIAGRAM/TERMINAL DESCRIPTION

## Q501 : LC78683E MP3 DECODER FOR CD

### BLOCK DIAGRAM

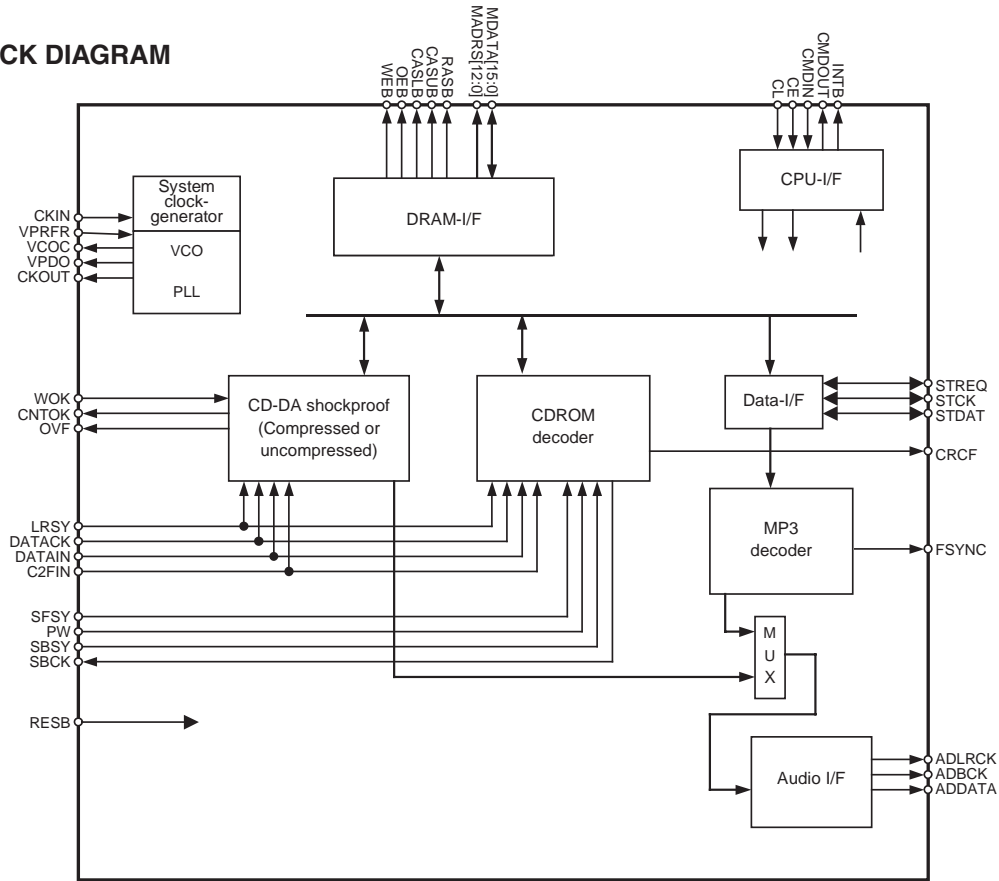

### PIN ASSIGNMENT

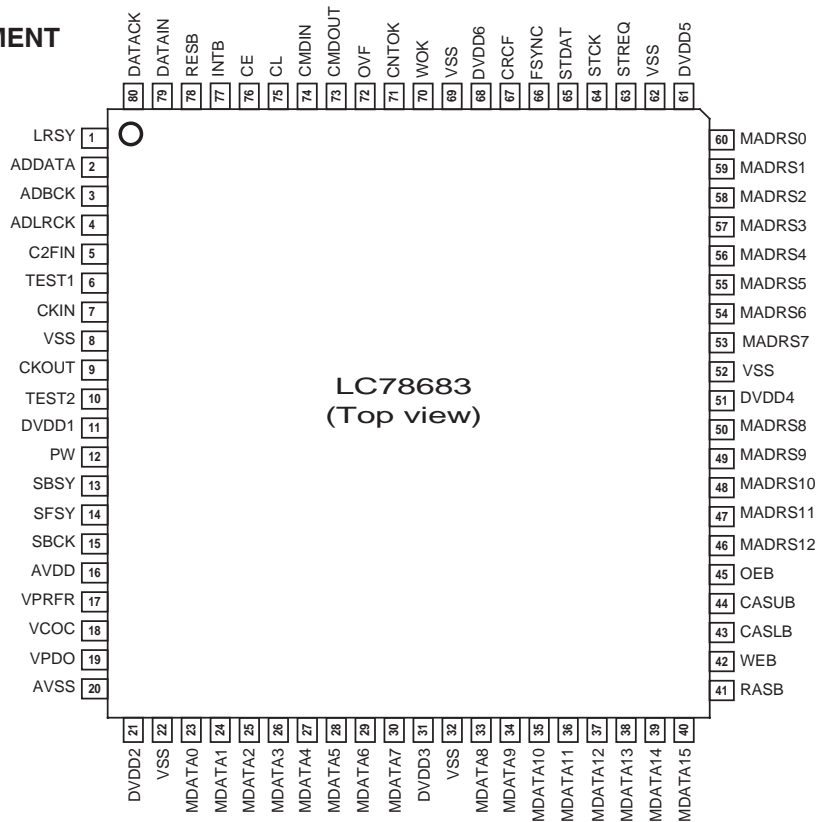

# IC BLOCK DIAGRAM/TERMINAL DESCRIPTION

## Q501 : LC78683E MP3 DECODER FOR CD

### Pin Functions

Pin No.	Pin Name	I/O	Block	Function
1	LRSY	I	CD IF	CD left/right clock input
2	ADDATA	O	Audio interface	Audio data output
3	ADBACK	O		Audio bit clock output
4	ADLRCK	O		Audio left/right clock output
5	C2FIN	I		CD IF
6	TEST1	I	Test	Test input 1 (This pin must be connected to ground during normal operation.)
7	CKIN	I	CLOCK	System clock input (16.9344 MHz)
8	VSS		Power supply	Ground
9	CKOUT	O	CLOCK	External digital filter and D/A converter clock (384 fs) output
10	TEST2	I	Test	Test input 2 (This pin must be connected to ground during normal operation.)
11	DV <sub>DD1</sub>		Power supply	Digital I/O system power supply
12	PW	I	Subcode interface	CD subcode data serial input
13	SBSY	I		CD subcode block sync signal input
14	SFSY	I		CD subcode frame sync signal input
15	SBCK	O		CD subcode transfer serial clock output
16	AV <sub>DD</sub>		Power supply	Analog system (PLL) power supply
17	VPRFR		PLL	VCO oscillator range setting
18	VCOC	I		VCO control voltage input
19	VPDO	O		VCO charge pump output
20	AVSS		Analog system ground	Analog system ground
21	DV <sub>DD2</sub>		Power supply	Internal logic system power supply
22	VSS			GND
23	MDATA0	I/O	Memory interface	DRAM data bus 0
24	MDATA1	I/O		DRAM data bus 1
25	MDATA2	I/O		DRAM data bus 2
26	MDATA3	I/O		DRAM data bus 3
27	MDATA4	I/O		DRAM data bus 4
28	MDATA5	I/O		DRAM data bus 5
29	MDATA6	I/O		DRAM data bus 6
30	MDATA7	I/O		DRAM data bus 7
31	DV <sub>DD3</sub>		Power supply	Digital I/O system power supply
32	VSS			GND
33	MDATA8	I/O	Memory interface	DRAM data bus 8
34	MDATA9	I/O		DRAM data bus 9
35	MDATA10	I/O		DRAM data bus 10
36	MDATA11	I/O		DRAM data bus 11
37	MDATA12	I/O		DRAM data bus 12
38	MDATA13	I/O		DRAM data bus 13
39	MDATA14	I/O		DRAM data bus 14
40	MDATA15	I/O		DRAM data bus 15
41	RASB	O		RAS output (active low)
42	WEB	O		WE output (active low)
43	CASLB	O		CAS output (lower byte, active low)
44	CASUB	O		CAS output (upper byte, active low)
45	OEB	O		OE output (active low)
46	MADRS12	O		DRAM address output 12
47	MADRS11	O		DRAM address output 11
48	MADRS10	O	DRAM address output 10	
49	MADRS9	O	DRAM address output 9	
50	MADRS8	O	DRAM address output 8	

Continued on next page.

# IC BLOCK DIAGRAM/TERMINAL DESCRIPTION

## Q501 : LC78683E MP3 DECODER FOR CD

Continued from preceding page.

Pin No.	Pin Name	I/O	Block	Function
51	DV <sub>DD4</sub>		Power supply	Digital I/O system power supply
52	V <sub>SS</sub>			Ground
53	MADRS7	O	Memory interface	DRAM address output 7
54	MADRS6	O		DRAM address output 6
55	MADRS5	O		DRAM address output 5
56	MADRS4	O		DRAM address output 4
57	MADRS3	O		DRAM address output 3
58	MADRS2	O		DRAM address output 2
59	MADRS1	O		DRAM address output 1
60	MADRS0	O		DRAM address output 0
61	DV <sub>DD5</sub>		Power supply	Internal logic system power supply
62	V <sub>SS</sub>			GND
63	STREQ	I/O	MP3 stream I/O	MP3 data request flag output (active high) /DRAM data request flag input (CD-ROM mode, active high)
64	STCK	I/O		MP3 data transfer clock input /DRAM data transfer clock output
65	STDAT	I/O		MP3 serial data input /DRAM serial data output
66	FSYNC	O	MP3-dec	MP3 frame sync signal (active high) /Data continuity point detection complete flag (CD-DA mode, active high)
67	CRCF	O	CD monitor	CRC check result output (CD-ROM data/CD-DA subcode data) /DRAM data output enable signal output (active high)
68	DV <sub>DD6</sub>		Power supply	Digital I/O system power supply
69	V <sub>SS</sub>			GND
70	WOK	I	CD-DA shockproof and MP3 I/O	DRAM write enable input (CD-DA mode, active high) /DRAM data request flag input
71	CNTOK	O		Data continuity point detection complete flag (CD-DA mode, active high) /SYNC error monitor flag (MP3 mode, active high)/DRAM serial data output
72	OVF	O		DRAM write interrupt flag (CD-DA mode, active high) /Emphasis output flag (CD-DA and MP3 modes, active high) /DRAM data transfer clock output
73	CMDOUT	O	Microcontroller interface	Serial command data output (n-channel open-drain output)
74	CMDIN	I		Serial command data input
75	CL	I		Serial command clock input
76	CE	I		Command enable input (active high)
77	INTB	O		Interrupt signal output (active low) /DRAM write interrupt flag (CD-DA mode, active high)
78	RESB	I		System reset (active low)
79	DATAIN	I	CD IF	Serial CD data input
80	DATAACK	I		CD bit clock input

**Notes:** 1. Notes on unused pins.

Unused input pins must be connected to the ground level (0V).

Unused output pins must be left open. Do not connect anything to the se pins.

Unused I/O pins may either be connected to the ground level (0V) or set to output mode and left open.

- The corresponding power supply levels must be provided all of the DV<sub>DD1</sub>, DV<sub>DD3</sub>, DV<sub>DD4</sub>, DV<sub>DD6</sub> and AV<sub>DD</sub> pins. The corresponding power supply level must also be provided to DV<sub>DD2</sub> and DV<sub>DD5</sub>.
- The TEST1 and TEST2 input pins must be connected to ground (0V).
- The I/O pins (MDAT0: 15, STREQ, STCK, and STDAT) go to input mode after a reset.
- After first applying the power supply levels, the RESB pin must be held low for at least 1us.
- A 16.9344MHz clock signal must be supplied to the CKIN pin by the CD DSP.  
The LC78684E does not support the implementation of an oscillator circuit using an oscillator element.



# IC BLOCK DIAGRAM / TERMINAL DESCRIPTION

## Q851: MPD4721GS RS-232C LINE DRIVER/ RECEIVER

### BLOCK DIAGRAM

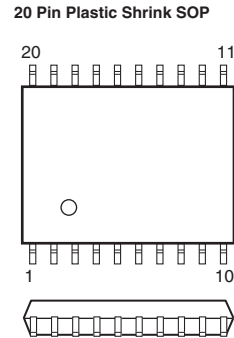
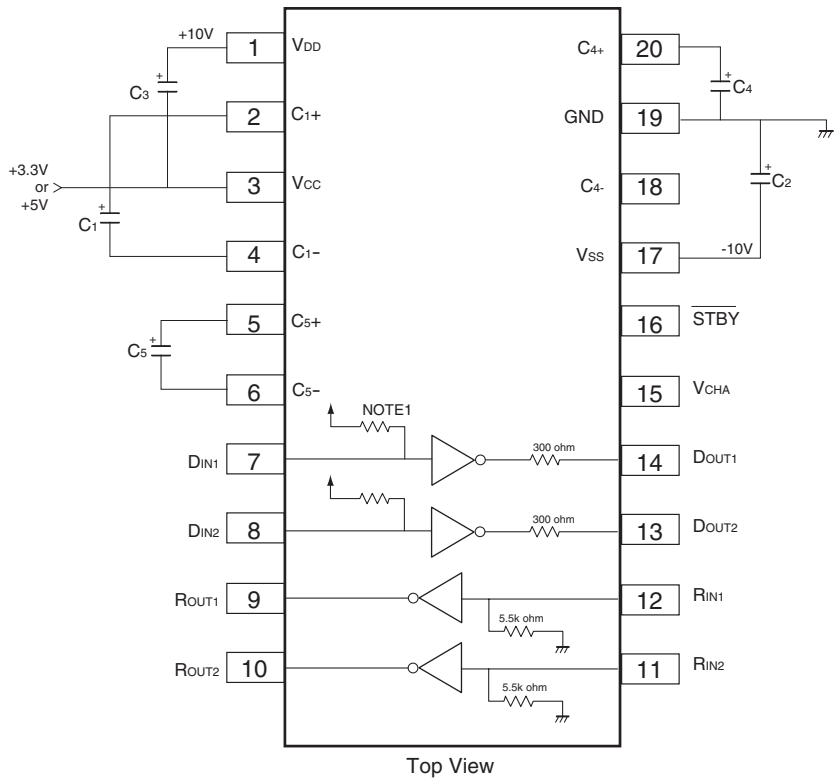

### Truth table

#### Driver

STBY	DIN	DOUT	Remarks
L	x	Z	Standby mode
H	L	H	Space level output
H	H	L	Mark level output

#### Receiver

STBY	RIN	ROUT	Remarks
L	x	H	Standby mode
H	L	H	Mark level input
H	H	L	Space level input

### 3V — 5V switching

VCHA	Operating mode
L	5 V mode (double step-up)
H	3 V mode (3 times step-up)

H : high-level, L : low-level, Z : high-impedance, x : H or L

## IC BLOCK DIAGRAM/TERMINAL DESCRIPTION

### Q601, Q602 : TA7291S (MOTOR DRIVER)

#### BLOCK DIAGRAM

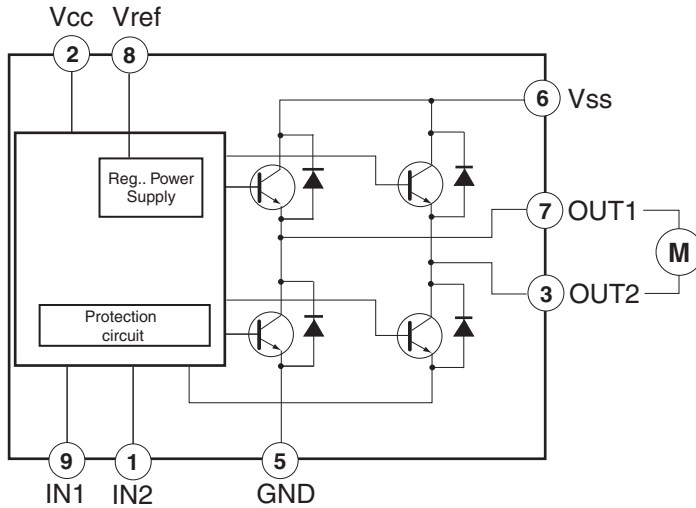

Truth table

INPUT		OUTPUT		MODE
IN1	IN2	OUT1	OUT2	
0	0	$\infty$	$\infty$	STOP
1	0	H	L	CW/CCW
0	1	L	H	CCW/CW
1	1	L	L	BRAKE

CW: Clockwise direction  
CCW: Counter clockwise direction

#### PIN FUNCTION

PIN No.	SYMBOL	FUNCTION DESCRIPTION
2	Vcc	Supply voltage terminal for Logic.
6	VS	Supply voltage terminal for Motor drive.
8	Vref	Supply voltage terminal for control.
5	GND	GND
9	IN1	Input
1	IN2	Input
7	OUT1	Output
3	OUT2	Output

Pin 4 : NC

# IC BLOCK DIAGRAM/TERMINAL DESCRIPTION

## Q153: TC74VHCT00AF

(Quad 2-input NAND gate)

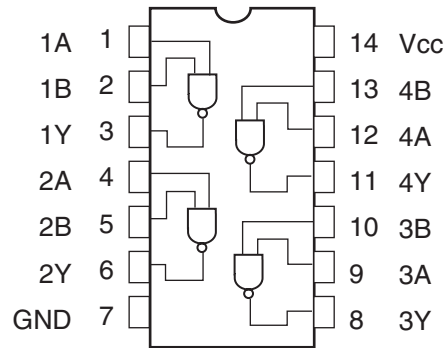

Truth table

A	B	Y
L	L	H
L	H	H
H	L	H
H	H	L

# IC BLOCK DIAGRAM/ TERMINAL DESCRIPTION

## Q903 : $\mu$ PC29M33T REGURATOR IC 3.3 V output

### BLOCK DIAGRAM

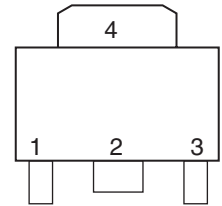
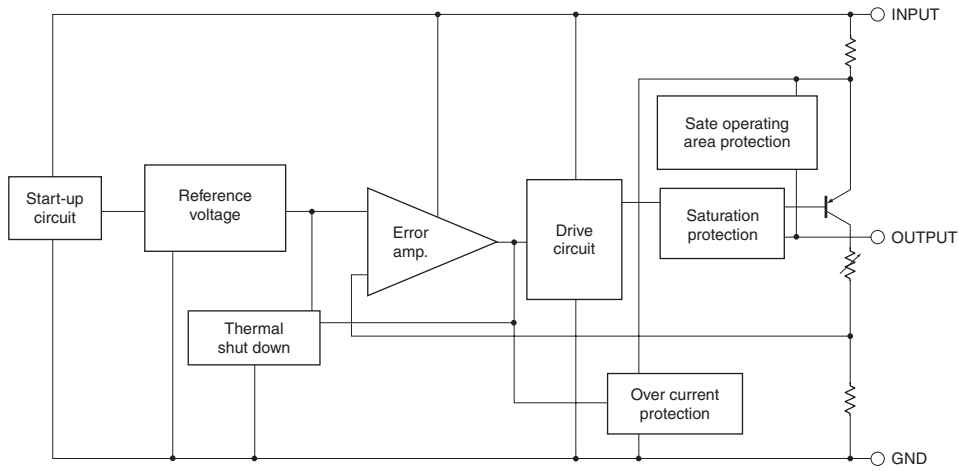

- 1 : Input
- 2 : GND
- 3 : Output
- 4 : GND (Fin)



## SUB MICROPROCESSOR TERMINAL DESCRIPTION-1

## Q801 : uPD780232GC

No.	PIN NAME	SIGNAL NAME	I/O	DESCRIPTION
1	VDD1	+5V	I	Power supply pin. (To connect +5V)
2	VSS1	GND	I	GND pin.
3	X1	CLOCK	I	Connect a clock OSC pin for main system.
4	X2	CLOCK	O	Connect a clock OSC pin for main system.
5	IC	GND	I	Internal connect pin.
6	~RESET	~SUBRST	I	Reset signal input pin from main processor.
7	P27/~SCK1	SUBCL	I	Communication to main microprocessor and clock input pin for write the flash microprocessor.
8	P26/SI1	SUBSI	I	Data input pin for write the flash microprocessor.
9	P25/SO1	SUBSO	O	Data output pin for write the flash microprocessor.
10	P24/BUSY	SUBREQ	O	Communication require output pin of a main microcomputer.
11	P23	GND	I	Not used. To connect GND.
12	P22	GND	I	Not used. To connect GND.
13	P21/SO3	STANDBYLED	O	Standby LED control output pin. H=Lighting, L=Light out
14	P20/~SCK3	TRAYLED1	O	Tray lighting LED control terminal 1.H=Lighting, L=Light out
15	P00/INTP0	~IRIN	I	Remote control signal input pin.
16	P01/INTP1	TRAYLED2	O	Tray illumination LED control pin 2.
17	P02/TI		O	Not used. Open pin.
18	AVSS	GND		GND pin for A/D converter.
19	ANI3	K3	I	Key input pin.
20	ANI2	K2	I	Key input pin.
21	ANI1	K1	I	Key input pin.
22	ANI0	K0	I	Key input pin.
23	VSS0	GND	I	GND pin.
24	AVDD	+5V	I	Power supply pin for A/D converter.
25	VDD0	+5V	I	Power supply pin. (To connect +5V)
26	P64/FIP52	FLON	O	Filament power supply control pin. H=ON/L=OFF
27	P63/FIP51		O	Not used. Open pin.
28	P62/FIP50		O	Not used. Open pin.
29	P61/FIP49		O	Not used. Open pin.
30	P60/FIP48		O	Not used. Open pin.
31	P57/FIP47		O	Not used. Open pin.
32	P56/FIP46		O	Not used. Open pin.
33	P55/FIP45		O	Not used. Open pin.
34	P54/FIP44		O	Not used. Open pin.
35	P53/FIP43		O	Not used. Open pin.
36	P52/FIP42		O	Not used. Open pin.
37	P51/FIP41		O	Not used. Open pin.
38	P50/FIP40		O	Not used. Open pin.
39	P47/FIP39		O	Not used. Open pin.
40	P46/FIP38		O	Not used. Open pin.
41	P45/FIP37		O	Not used. Open pin.
42	P44/FIP36		O	Not used. Open pin.
43	P43/FIP35		O	Not used. Open pin.
44	P42/FIP34	P19	O	FL tube segment output pin 19.
45	P41/FIP33	P18	O	FL tube segment output pin 18.
46	P40/FIP32	P17	O	FL tube segment output pin 17.
47	P37/FIP31	P16	O	FL tube segment output pin 16.
48	P36/FIP30	P15	O	FL tube segment output pin 15.
49	P35/FIP29	P14	O	FL tube segment output pin 14.
50	P34/FIP28	P13	O	FL tube segment output pin 13.
51	P33/FIP27	P12	O	FL tube segment output pin 12.
52	P32/FIP26	P11	O	FL tube segment output pin 11.
53	P31/FIP25	P10	O	FL tube segment output pin 10.

## SUB MICROPROCESSOR TERMINAL DESCRIPTION-2

## Q801 : uPD780232GC

No.	PIN NAME	SIGNAL NAME	I/O	DESCRIPTION
54	P30/FIP24	P9	O	FL tube segment output pin 9.
55	FIP23	P8	O	FL tube segment output pin 8.
56	FIP22	P7	O	FL tube segment output pin 7.
57	FIP21	P6	O	FL tube segment output pin 6.
58	FIP20	P5	O	FL tube segment output pin 5.
59	VDD2	+5V		Power supply pin. (To connect +5V)
60	VLOAD	-Vdisp		Negative power supply pin.
61	FIP19	P4	O	FL tube segment output pin 4.
62	FIP18	P3	O	FL tube segment output pin 3.
63	FIP17	P2	O	FL tube segment output pin 2.
64	FIP16	P1	O	FL tube segment output pin 1.
65	FIP15		O	Not used. Open pin.
66	FIP14		O	Not used. Open pin.
67	FIP13		O	Not used. Open pin.
68	FIP12		O	Not used. Open pin.
69	FIP11	12G	O	FL tube grid output pin 12.
70	FIP10	11G	O	FL tube grid output pin 11.
71	FIP9	10G	O	FL tube grid output pin 10.
72	FIP8	9G	O	FL tube grid output pin 9.
73	FIP7	8G	O	FL tube grid output pin 8.
74	FIP6	7G	O	FL tube grid output pin 7.
75	FIP5	6G	O	FL tube grid output pin 6.
76	FIP4	5G	O	FL tube grid output pin 5.
77	FIP3	4G	O	FL tube grid output pin 4.
78	FIP2	3G	O	FL tube grid output pin 3.
79	FIP1	2G	O	FL tube grid output pin 2.
80	FIP0	1G	O	FL tube grid output pin 1.



## MAIN MICROPROCESSOR TERMINAL DESCRIPTION-1

80 pin QFP

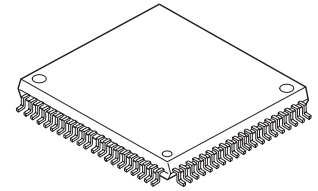

## Q701 : uPD784225GC

No.	PIN NAME	SIGNAL NAME	I/O	DESCRIPTION
1	P15/ANI5	GND	I	Not used. To connect GND pin.
2	P16/ANI6	GND	I	Not used. To connect GND pin.
3	P17/ANI7	GND	I	Not used. To connect GND pin.
4	AV <sub>ss</sub>	GND	I	GND
5	P130/ANO0		O	Not used. Open pin.
6	P131/ANO1		O	Not used. Open pin.
7	AV <sub>ref1</sub>	+5V	I	Power supply pin for A/D port.
8	P70/SI2/RxD2	RXD	I	Received pin of RS232C mode.
9	P71/SO2/TxD2	TXD	O	Output pin of RS232C mode
10	P72/-SCK2/ASCK2	GND	I	Not used. To connect GND pin.
11	P20/SI1/RxD1	MSI	I	Data input pin from MP3 decoder and sub code data form CD processor.
12	P21/SO1/TxD1	MSO	O	Transmitting data output pin to MP3 decoder and command data of CD processor.
13	P22/-SCK1/ASCK1	MSCK	O	Decoder clock output pin. Communicate to MP3 decoder.
14	P23/PCL	DOUT	O	Select the CD or MP3 output mode. L=MP3 H=CD
15	P24/BUZ	SUBRST	O	Reset signal output pin.
16	P25/SI0/SDA0	SUBSO	I	Serial data input pin from sub microprocessor.
17	P26/SO0	SUBSI	O	Serial data output pin to sub microprocessor.
18	P27/-SCK0/SCL0	SUBCL	O	Serial clock output pin to sub microprocessor.
19	P40/AD0	$\overline{\text{CDSUBQ}}$	O	Select the CD sub code output pin of serial port.
20	P41/AD1	$\overline{\text{CDCOM}}$	O	Select the CD command output pin of serial port.
21	P42/AD2	$\overline{\text{MP3COM}}$	O	Select the MP3 decoder output pin.
22	P43/AD3	$\overline{\text{MP3CE}}$	O	Chip enable signal output pin of MP3 decoder.
23	P44/AD4	SENSI	I	Sens input pin for CD signal processor.
24	P45/AD5	$\overline{\text{CDXLT}}$	O	Command latch output pin for CD signal processor.
25	P46/AD6	SCLKO	O	Sens reading clock output terminal to CD signal processor.
26	P47/AD7	FOKI	I	FOK signal input pin from signal processor.
27	P50/A8	LDON	O	Laser light control output pin. HiZ=OFF L=CD H=CD-RW
28	P51/A9	$\overline{\text{CDRESET}}$	O	Reset pin of MP3 decoder.
29	P52/A10	CDPOWER	O	Power supply control pin.
30	P53/A11	CDMUT	O	Analog mute pin. H=OFF/L=ON
31	P54/A12	STOP_POS_SEN	I	Detection the sensor input pin for disc position.
32	P55/A13	DISC_SENS	I	Disk existence detection optical sensor input terminal.
33	V <sub>ss1</sub>	GND	I	GND
34	P56/A14	$\overline{\text{ROT}}_R$	O	Roulette motor control pin-R.
35	P57/A15	$\overline{\text{ROT}}_L$	O	Roulette motor control pin-L.
36	P60/A16	ROTHI	O	Roulette motor speed control terminal..
37	P61/A17	LOADING_SW1	I	Loading clamp position detection switch input terminal 1.
38	P62/A18	LOADING_SW2	I	Loading clamp position detection switch input terminal 2.
39	P63/A19	LOADING_SW3	I	Loading clamp position detection switch input terminal 3.
40	P64/-RD	$\overline{\text{CURRENT}}$	I	Loading clamp motor current detection input terminal.
41	P65/-WR	$\overline{\text{LOADING}}_L$	O	Loading clamp motor control terminal L.
42	P66/-WAIT	$\overline{\text{LOADING}}_R$	O	Loading clamp motor control terminal R.
43	P67/ASTB		O	Not used. Open pin.
44	P30/TO0		O	Not used. Open pin.
45	P31/TO1	DITDI	I	The serial transmission data input terminal to DIT.
46	P32/TO2	DITDO	O	The serial transmission data output terminal to DIT.
47	P33/TI1	DITCL	O	The serial data transmission data output terminal to DIT.
48	P34/TI2	DITCE	O	The control command chip enable signal output terminal of DIT.
49	P35/TIO0	$\overline{\text{DITPD}}$	O	DIT power down signal output terminal.
50	P36/TIO1	EEPROMCS	O	Chip select signal output pin of EEPROM.
51	P37/EXA	EEPROMCLK	O	Serial clock signal output pin of EEPROM.
52	P120/RTP0	EEPROMDI	O	Serial data signal output pin to EEPROM.
53	P121/RTP1	EEPROMDO	I	Serial data signal input pin from EEPROM.
54	P122/RTP2	DACMUT	O	Digital mute signal of DAC. H=ON/L=OFF

# MAIN MICROPROCESSOR TERMINAL DESCRIPTION-2

## Q701 : uPD784225GC

No.	PIN NAME	SIGNAL NAME	I/O	DESCRIPTION
55	P123/RTP3	DACEMPHASYS	O	The de-emphasis control terminal of DAC. H=De-emphasis ON/L=OFF
56	P124/RTP4		O	Not used. Open pin.
57	P125/RTP5		O	Not used. Open pin.
58	P126/RTP6	SYSIN	I	RI system code input pin.
59	P127/RTP7	$\overline{\text{SYSOUT}}$	O	RI system code output pin.
60	~RESET	$\overline{\text{RESET}}$		Reset pin of microprocessor.
61	P00/INTP0	$\overline{\text{EXIRIN}}$	I	External IR input pin.
62	P01/INTP1	$\overline{\text{POFF}}$	I	Power failure detection terminal. L=Power failure
63	P02/INTP2/NMI	$\overline{\text{MP3INTB}}$	I	The interruption signal input terminal from MP3 decode.
64	P03/INTP3	SCORI	I	The sub code detection terminal of the signal processing IC.
65	P04/INTP4	SUBREQ	I	The communication ready signal input terminal from sub microprocessor.
66	P05/INTP5	MP3FSYNC	I	FSYNC signal input pin from MP3 decoder.
67	Vss0	GND	I	GND
68	Vdd1	+5V	I	Power supply pin.
69	X2	CLOCK	O	Clock signal output pin. (12.5MHz OSCO)
70	X1	CLOCK	I	Clock signal input pin. (12.5MHz OSC)
71	TEST/Vpp	GND	I	Flash ROM write-in voltage pin.
72	XT2		O	Not used. Open pin.
73	XT1	GND	I	Not used. To connect GND pin.
74	Vdd0	+5V	I	Power supply pin.
75	AVdd	+5V	I	Power supply pin for A/D port.
76	P10/ANI0	MODEL	I	Model name select pin. 0V=DX-C390/+5V=Other model
77	P11/ANI1	TIMING	I	The brake timing setting terminal of roulette. (0V=0msec ~ +5V=64msec)
78	P12/ANI2	GND	I	Not used. To connect GND pin.
79	P13/ANI3	GND	I	Not used. To connect GND pin.
80	P14/ANI4	GND	I	Not used. To connect GND pin.

### PIN LAYOUT

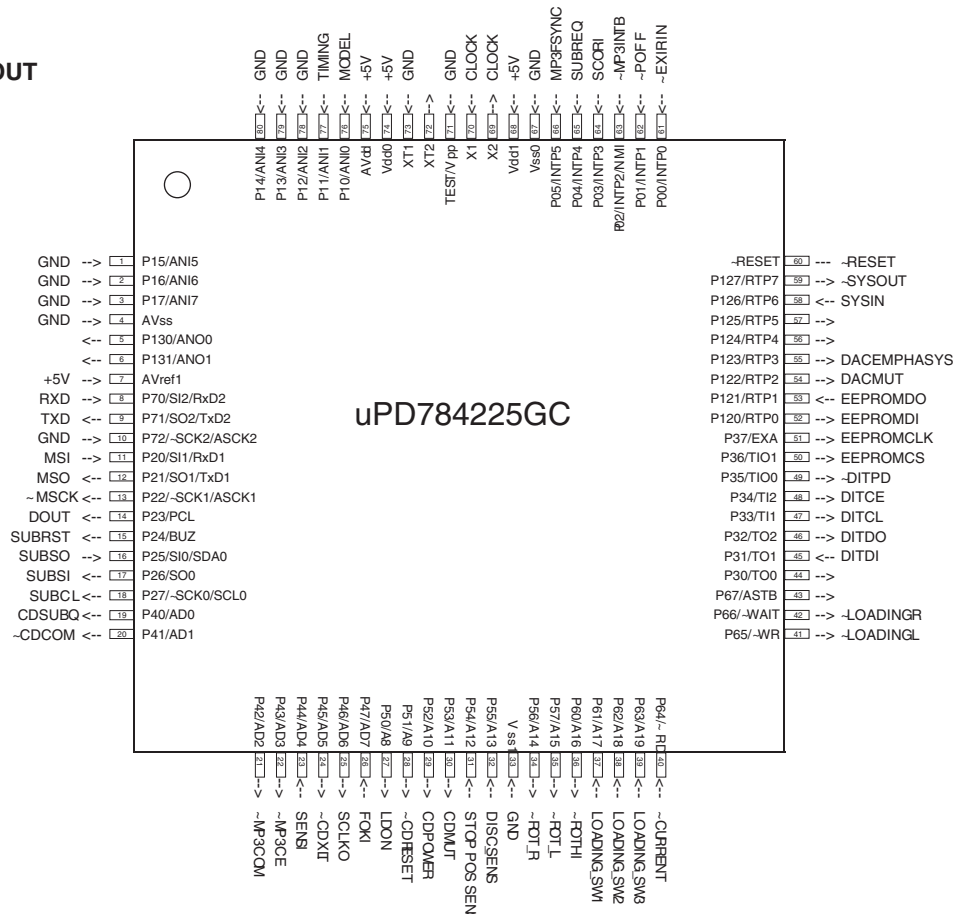

# PACKING VIEW

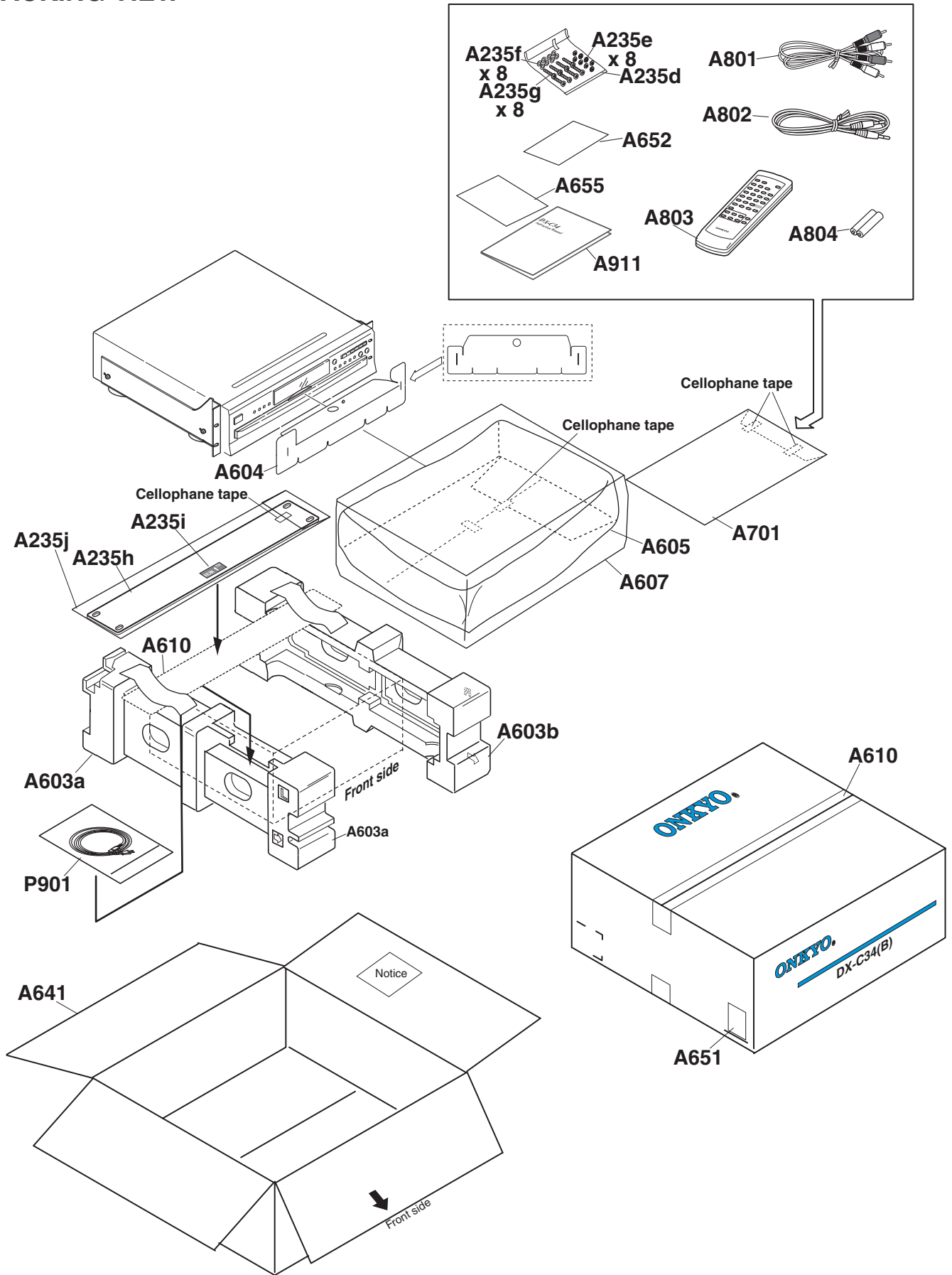

CIRCUIT NO.	PART NAME	DESCRIPTION	PART NO.	REMARKS	
DG-8053-1	C101	CHIP ELECT C	CEWX6.3V-100M	157B-107M-3-MJI	1
DG-8053-1	C102	C-CERA C	CK725B1C-104K1	150D-104K-P-AC	1
DG-8053-1	C103	C-CERA C	CK725B1H-332K1	150F-332K-P-AC	1
DG-8053-1	C104	CHIP ELECT C	CEWX6.3V-330M	157B-337M-3-OKI	1
DG-8053-1	C105	C-CERA C	CK725F1E-104Z1	150F-104K-P-AC	1
DG-8053-1	C106	CHIP ELECT C	CEWX16V-10M	157D-106M-3-HJI	1
DG-8053-1	C107	C-CERA C	CK725F1E-104Z1	150F-104K-P-AC	1
DG-8053-1	C108	CHIP ELECT C	CEWX6.3V-100M	157B-107M-3-MJI	1
DG-8053-1	C109	C-CERA C	CK725F1E-104Z1	150F-104K-P-AC	1
DG-8053-1	C110	C-CERA C	CK725B1H-473K1	150F-473K-P-AC	1
DG-8053-1	C111	C-CERA C	CK725F1E-104Z1	150F-104K-P-AC	1
DG-8053-1	C112	C-CERA C	CK725F1E-104Z1	150F-104K-P-AC	1
DG-8053-1	C113	C-CERA C	CC725CH1H-221J1	15CH-221J-P-AC	1
DG-8053-1	C114	C-CERA C	CK725B1C-104K1	150D-104K-P-AC	1
DG-8053-1	C115	C-CERA C	CC725CH1H-471J1	15CH-471J-P-AC	1
DG-8053-1	C117	CHIP ELECT C	CEWX50V-0.47M	157F-474M-3-HJI	1
DG-8053-1	C118	C-CERA C	CK725B1H-103K1	150F-103K-P-AC	1
DG-8053-1	C119	C-CERA C	CC725CH1H-221J1	15CH-221J-P-AC	1
DG-8053-1	C120	C-CERA C	CK725B1H-152K1	150F-152K-P-AC	1
DG-8053-1	C121	C-CERA C	CK725B1H-473K1	150F-473K-P-AC	1
DG-8053-1	C122	C-CERA C	CK725F1E-104Z1	150F-104K-P-AC	1
DG-8053-1	C123	CHIP ELECT C	CEWX6.3V-330M	157B-337M-3-OKI	1
DG-8053-1	C124	C-CERA C	CK725F1E-104Z1	150F-104K-P-AC	1
DG-8053-1	C125	C-CERA C	CK725F1E-104Z1	150F-104K-P-AC	1
DG-8053-1	C126	C-CERA C	CK725F1E-104Z1	150F-104K-P-AC	1
DG-8053-1	C129	CHIP ELECT C	CEWX6.3V-220M	157B-227M-3-OKI	1
DG-8053-1	C130	C-CERA C	CK725F1E-104Z1	150F-104K-P-AC	1
DG-8053-1	C131	CHIP ELECT C	CEWX6.3V-330M	157B-337M-3-OKI	1
DG-8053-1	C151	C-CERA C	CC725CH1H-150J1	15CH-150J-P-AC	1
DG-8053-1	C152	C-CERA C	CC725CH1H-180J1	15CH-180J-P-AC	1
DG-8053-1	C157	CHIP ELECT C	CEWX6.3V-47M	157B-476M-3-JJI	1
DG-8053-1	C159	CHIP ELECT C	CEWX6.3V-220M	157B-227M-3-OKI	1
DG-8053-1	C164	C-CERA C	CK725F1E-104Z1	150F-104K-P-AC	1
DIS-8054-1	C165	C-CERA C	CK725F1E-104Z1	150F-104K-P-AC	1
DIS-8054-1	C166	C-CERA C	CK725F1E-104Z1	150F-104K-P-AC	1
DIS-8054-1	C167	C-CERA C	CK725F1E-104Z1	150F-104K-P-AC	1
DIS-8054-1	C168	ELECT C	CE04W16V10M(SC)	157D-106M-K-IUI	1
DG-8053-1	C170	C-CERA C	CK725F1E-104Z1	150F-104K-P-AC	1
DG-8053-1	C172	C-CERA C	CK725F1C-224Z1	150D-224Z-P-AC	1
DIS-8054-1	C174	CERA C	CK45B50V-102K	150F-102K-K-II	1
DG-8053-1	C201	C-CERA C	CK725B1H-333K1	150F-333K-P-AC	1
DG-8053-1	C202	C-CERA C	CK725B1H-333K1	150F-333K-P-AC	1
DG-8053-1	C203	C-CERA C	CK725B1H-103K1	150F-103K-P-AC	1
DG-8053-1	C204	C-CERA C	CK725B1H-122K1	150F-122K-P-AC	1
DG-8053-1	C205	C-CERA C	CK725B1H-122K1	150F-122K-P-AC	1
DG-8053-1	C206	C-CERA C	CC725CH1H-681J1	15CH-681J-P-AC	1
DG-8053-1	C207	C-CERA C	CC725CH1H-681J1	15CH-681J-P-AC	1
DG-8053-1	C210	CHIP ELECT C	CEWX6.3V-330M	157B-337M-3-OKI	1
DIS-8054-1	C301	VX C	CE04W35V-22M(VX)	157Q-226M-K-IUI	1
DIS-8054-1	C302	VX C	CE04W35V-22M(VX)	157Q-226M-K-IUI	1
DIS-8054-1	C303	TF C	ECQ-B50V-102J	153F-102J-K-MMN	1
DIS-8054-1	C304	TF C	ECQ-B50V-102J	153F-102J-K-MMN	1
DIS-8054-1	C305	TF C	ECQ-B50V-272J	153F-272J-K-MMN	1
DIS-8054-1	C306	TF C	ECQ-B50V-272J	153F-272J-K-MMN	1
DIS-8054-1	C307	TF C	ECQ-B50V-182J	153F-182J-K-MMN	1
DIS-8054-1	C308	TF C	ECQ-B50V-182J	153F-182J-K-MMN	1



DIS-8054-1 C310	VX C	CE04W35V-22M(VX)	157Q-226M-K-IUI	1
DIS-8054-1 C311	ELECT C	CE04W16V220M(SC)	157D-227M-K-LUI	3/23 PAGE
DIS-8054-1 C312	ELECT C	CE04W16V220M(SC)	157D-227M-K-LUI	1
DIS-8054-1 C315	C-CERA C	CK725F1E-104Z1	150F-104K-P-AC	1
DG-8053-1 C501	C-CERA C	CK725F1E-104Z1	150F-104K-P-AC	1
DG-8053-1 C502	CHIP ELECT C	CEWX6.3V-220M	157B-227M-3-OKI	1
DG-8053-1 C503	C-CERA C	CK725F1E-104Z1	150F-104K-P-AC	1
DG-8053-1 C504	C-CERA C	CC725CH1H-330J1	15CH-330J-P-AC	1
DG-8053-1 C505	C-CERA C	CK725F1A-105Z1	150C-105Z-P-AC	1
DG-8053-1 C506	C-CERA C	CK725F1E-104Z1	150F-104K-P-AC	1
DG-8053-1 C507	C-CERA C	CK725F1E-104Z1	150F-104K-P-AC	1
DG-8053-1 C508	C-CERA C	CK725F1E-104Z1	150F-104K-P-AC	1
DG-8053-1 C509	C-CERA C	CK725F1E-104Z1	150F-104K-P-AC	1
DG-8053-1 C510	C-CERA C	CK725F1E-104Z1	150F-104K-P-AC	1
DG-8053-1 C511	C-CERA C	CK725F1E-104Z1	150F-104K-P-AC	1
DG-8053-1 C512	C-CERA C	CK725B1H-473K1	150F-473K-P-AC	1
DG-8053-1 C513	CHIP ELECT C	CEWX6.3V-220M	157B-227M-3-OKI	1
DG-8053-1 C514	C-CERA C	CK725F1E-104Z1	150F-104K-P-AC	1
DG-8053-1 C551	C-CERA C	CK725B1H-473K1	150F-473K-P-AC	1
DG-8053-1 C552	C-CERA C	CK725F1E-104Z1	150F-104K-P-AC	1
DIS-8054-1 C601	ELECT C	CE04W16V100M(SSK)	157D-107M-K-LII	1
DIS-8054-1 C602	C-CERA C	CK725F1H-223Z1	150F-223M-P-AC	1
DIS-8054-1 C605	C-CERA C	CK725F1E-104Z1	150F-104K-P-AC	1
DIS-8054-1 C606	ELECT C	CE04W16V100M(SSK)	157D-107M-K-LII	1
DIS-8054-1 C607	C-CERA C	CK725F1H-223Z1	150F-223M-P-AC	1
DIS-8054-1 C609	C-CERA C	CK725F1H-223Z1	150F-223M-P-AC	1
DIS-8054-1 C610	C-CERA C	CK725F1H-223Z1	150F-223M-P-AC	1
DIS-8054-1 C611	C-CERA C	CK725F1H-223Z1	150F-223M-P-AC	1
DIS-8054-1 C652	C-CERA C	CK725F1E-104Z1	150F-104K-P-AC	1
DIS-8054-1 C653	C-CERA C	CK725F1H-223Z1	150F-223M-P-AC	1
DIS-8054-1 C654	C-CERA C	CK725F1H-223Z1	150F-223M-P-AC	1
DIS-8054-1 C655	C-CERA C	CK725F1E-104Z1	150F-104K-P-AC	1
DIS-8054-1 C656	C-CERA C	CK725F1E-104Z1	150F-104K-P-AC	1
DG-8053-1 C701	C-CERA C	CK725F1E-104Z1	150F-104K-P-AC	1
DG-8053-1 C702	CHIP ELECT C	CEWX16V-10M	157D-106M-3-HJI	1
DG-8053-1 C703	C-CERA C	CK725F1E-104Z1	150F-104K-P-AC	1
DG-8053-1 C704	C-CERA C	CK725F1E-104Z1	150F-104K-P-AC	1
DG-8053-1 C705	C-CERA C	CK725F1E-104Z1	150F-104K-P-AC	1
DG-8053-1 C707	C-CERA C	CK725F1E-104Z1	150F-104K-P-AC	1
DG-8053-1 C709	C-CERA C	CK725F1E-104Z1	150F-104K-P-AC	1
DG-8053-1 C710	CHIP ELECT C	CEWX50V-2.2M	157F-225M-3-HJI	1
DG-8053-1 C711	C-CERA C	CC725CH1H-330J1	15CH-330J-P-AC	1
DG-8053-1 C713	C-CERA C	CK725F1E-104Z1	150F-104K-P-AC	1
DG-8053-1 C714	C-CERA C	CK725F1E-104Z1	150F-104K-P-AC	1
DG-8053-1 C715	C-CERA C	CK725F1E-104Z1	150F-104K-P-AC	1
DIS-8054-1 C801	ELECT C	CE04W6.3V100M(SSK)	157B-107M-K-LII	1
DIS-8054-1 C802	C-CERA C	CK725F1E-104Z1	150F-104K-P-AC	1
DIS-8054-1 C804	ELECT C	CE04W16V10M(SSK)	157D-106M-K-GII	1
DIS-8054-1 C806	C-CERA C	CK725F1E-104Z1	150F-104K-P-AC	1
DIS-8054-1 C807	C-CERA C	CK725F1H-223Z1	150F-223M-P-AC	1
DIS-8054-1 C808	ELECT C	CE04W50V2.2M(SSK)	157F-225M-K-GII	1
DIS-8054-1 C809	C-CERA C	CK725F1E-104Z1	150F-104K-P-AC	1
DIS-8054-1 C810	C-CERA C	CK725F1H-223Z1	150F-223M-P-AC	1
DIS-8054-1 C811	C-CERA C	CK725F1H-223Z1	150F-223M-P-AC	1
DIS-8054-1 C812	C-CERA C	CC725CH1H-330J1	15CH-330J-P-AC	1
DIS-8054-1 C813	C-CERA C	CC725CH1H-330J1	15CH-330J-P-AC	1
DIS-8054-1 C814	C-CERA C	CC725CH1H-101J1	15CH-101J-P-AC	1
DIS-8054-1 C815	C-CERA C	CC725CH1H-101J1	15CH-101J-P-AC	1
DIS-8054-1 C816	C-CERA C	CC725CH1H-101J1	15CH-101J-P-AC	1





DIS-8054-1 C852	ELECT C	CE04W50V-1M(SC)	157F-105M-K-IUI		1
DIS-8054-1 C853	ELECT C	CE04W6.3V100M(SC)	157B-107M-5-IUI		5/23 PAGE
DIS-8054-1 C854	C-CERA C	CK725F1E-104Z1	150F-104K-P-AC		1
DIS-8054-1 C855	ELECT C	CE04W50V-1M(SC)	157F-105M-K-IUI		1
DIS-8054-1 C856	ELECT C	CE04W50V-1M(SC)	157F-105M-K-IUI		1
DIS-8054-1 C857	ELECT C	CE04W6.3V100M(SC)	157B-107M-5-IUI		1
DIS-8054-1 C858	TF C	ECQ-B50V-223J	153F-223J-K-MMN		1
DIS-8054-1 C901	IS C	DE1307E472M-KH	150R-472M-5-SW		1
DIS-8054-1 C902	IS C	DE1307E472M-KH	150R-472M-5-SW		1
DIS-8054-1 C903	TF C	ECQ-V50V-334J	153F-334J-K-MMN		1
DIS-8054-1 C904	ELECT C	CE04W16V10000M(SC)	157D-109M-5-7^I	N	1
DIS-8054-1 C905	ELECT C	CE04W16V2200M(SC)	157D-228M-5-X=I	N	1
DIS-8054-1 C906	ELECT C	CE04W16V10M(SC)	157D-106M-K-IUI		1
DIS-8054-1 C908	ELECT C	CE04W50V100M(SC)	157F-107M-K-OVI		1
DIS-8054-1 C909	C-CERA C	CK725F1H-223Z1	150F-223M-P-AC		1
DIS-8054-1 C910	ELECT C	CE04W35V47M(SC)	157Q-476M-K-IUI		1
DIS-8054-1 C911	ELECT C	CE04W16V10M(SC)	157D-106M-K-IUI		1
DIS-8054-1 C912	TF C	ECQ-V50V-104J	153F-104J-K-MMN		1
DIS-8054-1 C913	ELECT C	CE04W16V10M(SC)	157D-106M-K-IUI		1
DIS-8054-1 C915	ELECT C	CE04W16V220M(SC)	157D-227M-K-LUI		1
DIS-8054-1 C916	TF C	ECQ-V50V-334J	153F-334J-K-MMN		1
DIS-8054-1 C917	TF C	ECQ-V50V-224J	153F-224J-K-MMN		1
DG-8053-1 D101	C-DIODE	1SS355	4840-1660-0		1
DG-8053-1 D101 or	C-DIODE	1SS352	480S-3520-3		(1)
DIS-8054-1 D301	ZENER D	UDZ4.7B	483H-4V71-3		1
DIS-8054-1 D601	ZENER D	UDZ2.2B	483H-2V21-3		1
DIS-8054-1 D602	ZENER D	UDZ2.7B	483H-2V71-3		1
DIS-8054-1 D603	ZENER D	UDZS4.3B	483H-4B31-3		1
DIS-8054-1 D604	ZENER D	UDZS4.7B	483H-4V71-3		1
DG-8053-1 D701	C-DIODE	1SS355	4840-1660-0		1
DG-8053-1 D701 or	C-DIODE	1SS352	480S-3520-3		(1)
DG-8053-1 D703	C-DIODE	1SS355	4840-1660-0		1
DG-8053-1 D703 or	C-DIODE	1SS352	480S-3520-3		(1)
DG-8053-1 D704	ZENER D	UDZS5.6B	483H-5B61-3		1
DIS-8054-1 D801	LED	SLR-342VR	3700-2531-R		1
DIS-8054-1 D802	LED	SELU2L10C	3700-2832-B		1
DIS-8054-1 D802A	HOLDER	(LED)LA-5-6	4171-0021-0		1
DIS-8054-1 D803	LED	SELU2L10C	3700-2832-B		1
DIS-8054-1 D803A	HOLDER	(LED)LA-5-6	4171-0021-0		1
DIS-8054-1 D804	ZENER D	UDZS11B	483H-1101-3		1
DIS-8054-1 D901	DIODE	D3SBA20	480A-20F0-5		1
DIS-8054-1 D905	DIODE	RL1N4003	4804-0030-K		1
DIS-8054-1 D905 or	DIODE	GP104003E	4800-03E0-K		(1)
DIS-8054-1 D906	ZENER D	UDZS30B	483H-3001-3		1
DIS-8054-1 D907	C-DIODE	1SS355	4840-1660-0		1
DIS-8054-1 D907 or	C-DIODE	1SS352	480S-3520-3		(1)
DIS-8054-1 D908	C-DIODE	1SS355	4840-1660-0		1
DIS-8054-1 D908 or	C-DIODE	1SS352	480S-3520-3		(1)
DIS-8054-1 D909	ZENER D	UDZS5.1B	483H-5V11-3		1
DG-8053-1 E201	WS CLAMP	CP-1S	6360-9650-0		1
DIS-8054-1 E701	PWB	NCDIS-8054	1725-705A-0100	N	1
DIS-8054-1 E702	PWB	NCSW-8055	1725-705A-0100	N	{ 1 }
DIS-8054-1 E703	PWB	NCAR-8056	1725-705A-0100	N	{ 1 }
DIS-8054-1 E704	PWB	NCDG-8057	1725-705A-0100	N	{ 1 }
DIS-8054-1 E705	PWB	NCPS-8058	1725-705A-0100	N	{ 1 }
DIS-8054-1 E706	PWB	NCETC-8059	1725-705A-0100	N	{ 1 }
DIS-8054-1 E707	PWB	NCETC-8060	1725-705A-0100	N	{ 1 }
DIS-8054-1 E708	PWB	NCETC-8061	1725-705A-0100	N	{ 1 }
DIS-8054-1 E709	PWB	NCETC-8062	1725-705A-0100	N	{ 1 }



DIS-8054-1 E711	PWB	NCPS-8064	1725-705A-0100		{ 1 }
DIS-8054-1 E712	PWB	NCDG-8065	1725-705A-0100		7/231PAGE
DG-8053-1 E801	PWB	NCDG-8053	1725-706A-0101	N	1
DIS-8054-1 E901	HOLDER	(CRAMP) UA-0 V0	4154-4281-0		1
DIS-8054-1 J1	PVC	1007#24 .2/7HAND B	7012-6789-0		1
DIS-8054-1 J903	CRIMP AS	CRIMP AS	7012-6666-0		1
DIS-8054-1 J904	CRIMP AS	CRIMP AS	7012-6667-0		1
DG-8053-1 L101	CHOKE COIL	NCH-1475	1803-0055-0		1
DG-8053-1 L102	CHOKE COIL	BLM21B222SPT	1803-0057-0		1
DG-8053-1 L103	CHOKE COIL	BLM21B222SPT	1803-0057-0		1
DG-8053-1 L104	CHOKE COIL	BLM21B222SPT	1803-0057-0		1
DG-8053-1 L151	CHOKE COIL	BLM21B222SPT	1803-0057-0		1
DIS-8054-1 L152	CHOKE COIL	BLM21B222SPT	1803-0057-0		1
DIS-8054-1 L153	CHOKE COIL	BLM21B222SPT	1803-0057-0		1
DG-8053-1 L154	CHOKE COIL	BLM21B222SPT	1803-0057-0		1
DG-8053-1 L155	CHOKE COIL	BLM21B222SPT	1803-0057-0		1
DG-8053-1 L156	CHOKE COIL	BLM21BB221SN1	1803-0084-0		1
DG-8053-1 L157	MPX COIL	NSRF-2046	5600-3456-T		1
DG-8053-1 L158	CHOKE COIL	BLM21B222SPT	1803-0057-0		1
DIS-8054-1 L159	CHOKE COIL	BLM21B222SPT	1803-0057-0		1
DG-8053-1 L202	CHOKE COIL	BLM21B222SPT	1803-0057-0		1
DG-8053-1 L501	CHOKE COIL	BLM21B222SPT	1803-0057-0		1
DG-8053-1 L502	CHOKE COIL	BLM21B222SPT	1803-0057-0		1
DG-8053-1 L503	CHOKE COIL	BLM21B222SPT	1803-0057-0		1
DIS-8054-1 L851	EMIFIL	BK1608LM182-T	1806-3647-0		1
DIS-8054-1 L852	EMIFIL	BK1608LM182-T	1806-3647-0		1
DIS-8054-1 L853	EMIFIL	BK1608LM182-T	1806-3647-0		1
DIS-8054-1 L854	EMIFIL	BK1608LM182-T	1806-3647-0		1
DIS-8054-1 L855	CHOKE COIL	NCH-1571	1803-0082-0		1
DIS-8054-1 L901	CHOKE COIL	BLM21B222SPT	1803-0057-0		1
DG-8053-1 P101A	SOCKET	NSCT-16P2380	2101-1515-0		1
DG-8053-1 P101Aor	SOCKET	CF09161H200	2113-1862-0.V	N	( 1 )
DG-8053-1 P102A	PLUG	2003P0300T	2101-1516-0	N	1
DIS-8054-1 P102B	PLUG	2002P0300T	2101-3008-0	N	1
DG-8053-1 P103A	PLUG	2003P0500T	2101-3013-0	N	1
DIS-8054-1 P103B	PLUG	2002P0500T	2101-3032-0	N	1
DIS-8054-1 P151	PIN JACK	NPJ-2PDRW435	2113-2020-0		1
DIS-8054-1 P152	PIN JACK	NPJ-1PDOR369	2113-2021-0		1
DIS-8054-1 P153	PIN JACK	NPJ-2PDB400	No GPE P/n		1
DG-8053-1 P201A	PLUG	NPLG-6P932	2101-1410-0		1
DG-8053-1 P701A	SOCKET	NSCT-17P2251	2101-1511-0		1
DIS-8054-1 P701B	SOCKET	NSCT-17P2251	2101-1511-0		1
DIS-8054-1 P702A	SOCKET	NSCT-6P2099	2101-1421-0		1
DIS-8054-1 P702Aor	SOCKET	NSCT-6P1600	2101-1538-0		( 1 )
DIS-8054-1 P702Aor	SOCKET	NSCT-6P1802	2101-1540-0		( 1 )
DIS-8054-1 P702B	SOCKET	NSCT-6P2136	2101-1422-0		1
DIS-8054-1 P702Bor	SOCKET	NSCT-6P1839	2101-1541-0		( 1 )
DIS-8054-1 P702Bor	SOCKET	NSCT-6P1637	2101-1539-0		( 1 )
DIS-8054-1 P703A	SOCKET AS	NSAS-4P1127	7012-6545-0		1
DIS-8054-1 P703B	PLUG	NPLG-2P422	2101-1424-0		1
DIS-8054-1 P704A	SOCKET AS	NSAS-4P1138	7012-6554-0		1
DIS-8054-1 P704B	PLUG	NPLG-2P940	2101-1451-0		1
DIS-8054-1 P705A	SOCKET AS	001-0404-H	7012-6663-0	N	1
DIS-8054-1 P705B	PLUG	2002P0700T	2101-3009-0	N	1
DIS-8054-1 P751A	SOCKET AS	NSAS-22P1126	7012-6542-0		1
DIS-8054-1 P751B	PLUG	NPLG-11P431	2101-1418-0		1
DIS-8054-1 P752	SOCKET AS	NSAS-22P1253	7012-6748-0	N	1
DIS-8054-1 P801A	SOCKET AS	NSAS-6P1231	7012-6664-0	N	1
DIS-8054-1 P801B	PLUG	NPLG-3P941	2101-1415-0		1



DIS-8054-1 P802B	PLUG	NPLG-2P940	2101-1451-0		1
DIS-8054-1 P851	SOCKET	NSCT-9P2277	2101-1492-0		9/23 PAGE
DIS-8054-1 P852	ST JACK	HSJ1002-01-1020	2113-2038-0		1
DG-8053-1P853A	SOCKET AS	NSAS-10P1228	7012-6668-0		1
DIS-8054-1 P853B	PLUG	NPLG-5P425	2101-1425-0		1
DIS-8054-1 P902A	SOCKET AS	001-0405-H	7012-6660-0	N	1
DIS-8054-1 P902B	PLUG	2531P0600T	2101-3033-0	N	1
DG-8053-1 P904A	PLUG	NPLG-10P948	2101-1518-0		1
DIS-8054-1 P904B	PLUG	NPLG-10P430	2101-1514-0		1
DIS-8054-1 P951	AC INLET	NPLG-2P913	2113-3043-0		1
DG-8053-1 Q101	TR	2SA1162-O	4851-1620-3		1
DG-8053-1 Q102	IC	CXA2581N	3131-8030-0		1
DG-8053-1 Q103	IC	CXD3068Q	3132-1170-0		1
DG-8053-1 Q151	IC	TC7WU04FU	3131-7940-0		1
DG-8053-1 Q152	IC	WM8726	3132-0970-0		1
DG-8053-1 Q153	IC	TC74VHCT00AFT	3132-0370-0		1
DG-8053-1 Q154	IC(REGULATOR)	MPC29L05T	3131-9980-0		1
DG-8053-1 Q155	IC	TC74VHCU04FT	3131-9960-0		1
DIS-8054-1 Q156	PHT CP	TOTX179	481T-X179-3		1
DG-8053-1 Q201	IC	BA5984FP	3132-0400-0		1
DIS-8054-1 Q301	IC	NJM4580M-D	3131-9970-0		1
DIS-8054-1 Q302	IC	NJM4580M-D	3131-9970-0		1
DIS-8054-1 Q303	IC	NJM4580M-D	3131-9970-0		1
DIS-8054-1 Q305	TR	2SD655-E	485D-655E-K		1
DIS-8054-1 Q305 or	TR	2SD655-F	4860-1780-5		(1)
DIS-8054-1 Q306	TR	2SD655-E	485D-655E-K		1
DIS-8054-1 Q306 or	TR	2SD655-F	4860-1780-5		(1)
DIS-8054-1 Q307	TR	DTA124EKA	4860-1110-3		1
DIS-8054-1 Q307 or	TR	RN2403	4852-4030-3		(1)
DIS-8054-1 Q307 or	TR	KRA103S	4851-03S0-3		(1)
DG-8053-1 Q501	IC	LC78683E	3132-0930-0	N	1
DG-8053-1 Q502	IC	IC41LV16100-50T	3132-0050-0		1
DG-8053-1 Q551	IC	AK4103VF	3132-0910-0	N	1
DIS-8054-1 Q601	IC	TA7291S	3131-7990-0		1
DIS-8054-1 Q602	IC	TA7291S	3131-7990-0		1
DIS-8054-1 Q603	TR	DTC114YKA	485C-1140-3		1
DIS-8054-1 Q603 or	TR	RN1407	4851-4070-3		(1)
DIS-8054-1 Q603 or	TR	KRC107S	4851-07S0-3		(1)
DIS-8054-1 Q604	TR	DTC114YKA	485C-1140-3		1
DIS-8054-1 Q604 or	TR	RN1407	4851-4070-3		(1)
DIS-8054-1 Q604 or	TR	KRC107S	4851-07S0-3		(1)
DIS-8054-1 Q605	TR	DTC114YKA	485C-1140-3		1
DIS-8054-1 Q605 or	TR	RN1407	4851-4070-3		(1)
DIS-8054-1 Q605 or	TR	KRC107S	4851-07S0-3		(1)
DIS-8054-1 Q606	TR	DTC114YKA	485C-1140-3		1
DIS-8054-1 Q606 or	TR	RN1407	4851-4070-3		(1)
DIS-8054-1 Q606 or	TR	KRC107S	4851-07S0-3		(1)
DIS-8054-1 Q607	TR	DTC114YKA	485C-1140-3		1
DIS-8054-1 Q607 or	TR	RN1407	4851-4070-3		(1)
DIS-8054-1 Q607 or	TR	KRC107S	4851-07S0-3		(1)
DIS-8054-1 Q608	TR	2SA1162-O	4851-1620-3		1
DIS-8054-1 Q651	PHT INT	GP2S28	481P-2S28-3		1
DIS-8054-1 Q652	PHT CP	RPI-576	481P-I576-3		1
DG-8053-1 Q701	IC	MPD784225GC-266-8BT	3132-0950-1	N	1
DG-8053-1 Q702	TR	DTC114EKA	4860-1350-3		1
DG-8053-1 Q702 or	TR	RN1402	4851-4020-3		(1)
DG-8053-1 Q702 or	TR	KRC104S	4851-04S0-3		(1)
DG-8053-1 Q703	IC	TC74VHCT08AFT	3132-0460-0		1
DG-8053-1 Q704	IC	TC74VHCT32AFT	3132-0470-0		1



DG-8053-1 Q706	IC	BR93L56F-WE2	3132-0920-0	N	1
DG-8053-1 Q709	TR	DTA124EKA	4860-1110-3		11/23 PAGE
DG-8053-1 Q709 or	TR	RN2403	4852-4030-3		(1)
DG-8053-1 Q709 or	TR	KRA103S	4851-03S0-3		(1)
DIS-8054-1 Q801	IC	MPD780232GC-091-8BT	3132-0940-0		1
DIS-8054-1 Q802	FL TUBE	HNV-12SM57	2460-2070-0	N	1
DIS-8054-1 Q802A	HOLDER	(FL)	4154-7161-0	N	1
DIS-8054-1 Q803	TR	2SC2859-Y	4852-859Y-3		1
DIS-8054-1 Q804	TR	2SC2859-Y	4852-859Y-3		1
DIS-8054-1 Q805	TR	RN2402	4852-4020-3		1
DIS-8054-1 Q806	TR	RN2402	4852-4020-3		1
DIS-8054-1 Q807	TR	RN2402	4852-4020-3		1
DIS-8054-1 Q808	TR	DTC114YKA	485C-1140-3		1
DIS-8054-1 Q808 or	TR	RN1407	4851-4070-3		(1)
DIS-8054-1 Q808 or	TR	KRC107S	4851-07S0-3		(1)
DIS-8054-1 Q809	TR	DTC114YKA	485C-1140-3		1
DIS-8054-1 Q809 or	TR	RN1407	4851-4070-3		(1)
DIS-8054-1 Q809 or	TR	KRC107S	4851-07S0-3		(1)
DIS-8054-1 Q810	REMO SENS	SPS-440-1-VP	4814-01VP-3		1
DIS-8054-1 Q811	TR	DTC114YKA	485C-1140-3		1
DIS-8054-1 Q811 or	TR	RN1407	4851-4070-3		(1)
DIS-8054-1 Q811 or	TR	KRC107S	4851-07S0-3		(1)
DIS-8054-1 Q851	IC	MPD4721GS	3132-0630-0		1
DIS-8054-1 Q852	PHT CP	ON3131	481N-3131-3		1
DIS-8054-1 Q853	TR	DTC114EKA	4860-1350-3		1
DIS-8054-1 Q853 or	TR	RN1402	4851-4020-3		(1)
DIS-8054-1 Q853 or	TR	KRC102S	4851-02S0-3		(1)
DIS-8054-1 Q854	TR	DTC114EKA	4860-1350-3		1
DIS-8054-1 Q854 or	TR	RN1402	4851-4020-3		(1)
DIS-8054-1 Q854 or	TR	KRC102S	4851-02S0-3		(1)
DIS-8054-1 Q901	IC(REGULATOR)	MPC2905HF	3131-7840-0		1
DIS-8054-1 Q901A	HEAT SINK	RAD-141	5400-3491-0		1
DIS-8054-1 Q901B	SCREW	3P+10FN(BC)	2900-3010-3000		1
DIS-8054-1 Q902	TR	2SA950-O	485A-950O-K		1
DIS-8054-1 Q902 or	TR	2SA950-Y	485A-950Y-K		(1)
DIS-8054-1 Q903	IC(REGULATOR)	MPC29M33T	3132-0160-0		1
DIS-8054-1 Q904	TR	2SA1182-O	4851-182O-3		1
DIS-8054-1 Q905	TR	DTC114YKA	485C-1140-3		1
DIS-8054-1 Q905 or	TR	RN1407	4851-4070-3		(1)
DIS-8054-1 Q905 or	TR	KRC107S	4851-07S0-3		(1)
DG-8053-1 R101	C-CARBON R	RN72K1J-103JE	4723-103J-P-R		1
DG-8053-1 R102	C-CARBON R	RN72K1J-103JE	4723-103J-P-R		1
DG-8053-1 R103	C-CARBON R	RN72K1J-101JE	4723-101J-P-R		1
DG-8053-1 R104	C-CARBON R	RN72K1J-470JE	4723-470J-P-R		1
DG-8053-1 R105	C-CARBON R	RN72K1J-470JE	4723-470J-P-R		1
DG-8053-1 R107	C-CARBON R	RN72K1J-104JE	4723-104J-P-R		1
DG-8053-1 R108	C-CARBON R	RN72K1J-103JE	4723-103J-P-R		1
DG-8053-1 R109	C-CARBON R	RN72K1J-103JE	4723-103J-P-R		1
DG-8053-1 R110	C-CARBON R	RN72K1J-154JE	4723-154J-P-R		1
DG-8053-1 R111	C-CARBON R	RN72K1J-682JE	4723-682J-P-R		1
DG-8053-1 R112	C-CARBON R	RN72K1J-153JE	4723-153J-P-R		1
DG-8053-1 R113	C-CARBON R	RN72K1J-103JE	4723-103J-P-R		1
DG-8053-1 R114	C-CARBON R	RN72K1J-103JE	4723-103J-P-R		1
DG-8053-1 R115	C-CARBON R	RN72K1J-183JE	4723-183J-P-R		1
DG-8053-1 R116	C-CARBON R	RN72K1J-562JE	4723-562J-P-R		1
DG-8053-1 R117	C-CARBON R	RN72K1J-393JE	4723-393J-P-R		1
DG-8053-1 R118	C-CARBON R	RN72K1J-512JE	4723-512J-P-R		1
DG-8053-1 R119	C-CARBON R	RN72K1J-822JE	4723-822J-P-R		1
DG-8053-1 R120	C-CARBON R	RN72K1J-332JE	4723-332J-P-R		1





DG-8053-1 R122	C-CARBON R	RN72K1J-222JE	4723-222J-P-R	1
DG-8053-1 R123	C-CARBON R	RN72K1J-000JE	4723-000J-P-R	13/23 PAGE
DG-8053-1 R124	C-CARBON R	RN72K1J-471JE	4723-471J-P-R	1
DG-8053-1 R125	C-CARBON R	RN72K1J-222JE	4723-222J-P-R	1
DG-8053-1 R126	C-CARBON R	RN72K1J-222JE	4723-222J-P-R	1
DG-8053-1 R127	C-CARBON R	RN72K1J-222JE	4723-222J-P-R	1
DG-8053-1 R128	C-CARBON R	RN72K1J-331JE	4723-331J-P-R	1
DG-8053-1 R129	C-CARBON R	RN72K1J-152JE	4723-152J-P-R	1
DG-8053-1 R130	C-CARBON R	RN72K1J-331JE	4723-331J-P-R	1
DG-8053-1 R131	C-CARBON R	RN72K1J-331JE	4723-331J-P-R	1
DG-8053-1 R132	C-CARBON R	RN72K1J-332JE	4723-332J-P-R	1
DG-8053-1 R133	C-CARBON R	RN72K1J-393JE	4723-393J-P-R	1
DG-8053-1 R134	C-CARBON R	RN72K1J-124JE	4723-124J-P-R	1
DG-8053-1 R135	C-CARBON R	RN72K1J-393JE	4723-393J-P-R	1
DG-8053-1 R136	C-CARBON R	RN72K1J-105JE	4723-105J-P-R	1
DG-8053-1 R137	C-CARBON R	RN72K1J-333JE	4723-333J-P-R	1
DG-8053-1 R138	C-CARBON R	RN72K1J-103JE	4723-103J-P-R	1
DG-8053-1 R139	C-CARBON R	RN72K1J-104JE	4723-104J-P-R	1
DG-8053-1 R140	C-CARBON R	RN72K1J-105JE	4723-105J-P-R	1
DG-8053-1 R141	C-CARBON R	RN72K1J-103JE	4723-103J-P-R	1
DG-8053-1 R142	C-CARBON R	RN72K1J-332JE	4723-332J-P-R	1
DG-8053-1 R143	C-CARBON R	RN72K1J-332JE	4723-332J-P-R	1
DG-8053-1 R144	C-CARBON R	RN72K1J-474JE	4723-474J-P-R	1
DG-8053-1 R145	C-CARBON R	RN72K1J-105JE	4723-105J-P-R	1
DG-8053-1 R146	C-CARBON R	RN72K1J-331JE	4723-331J-P-R	1
DG-8053-1 R147	C-CARBON R	RN72K1J-101JE	4723-101J-P-R	1
DIS-8054-1 R148	C-CARBON R	RN72K1J-471JE	4723-471J-P-R	1
DG-8053-1 R149	C-CARBON R	RN72K1J-010JE	4723-1R0J-P-R	1
DG-8053-1 R150	C-CARBON R	RN72K1J-000JE	4723-000J-P-R	1
DG-8053-1 R151	C-CARBON R	RN72K1J-221JE	4723-221J-P-R	1
DG-8053-1 R152	C-CARBON R	RN72K1J-105JE	4723-105J-P-R	1
DG-8053-1 R153	C-CARBON R	RN72K1J-222JE	4723-222J-P-R	1
DG-8053-1 R154	C-CARBON R	RN72K1J-222JE	4723-222J-P-R	1
DG-8053-1 R155	C-CARBON R	RN72K1J-102JE	4723-102J-P-R	1
DG-8053-1 R156	C-CARBON R	RN72K1J-102JE	4723-102J-P-R	1
DG-8053-1 R158	C-CARBON R	RN72K1J-471JE	4723-471J-P-R	1
DG-8053-1 R159	C-CARBON R	RN72K1J-000JE	4723-000J-P-R	1
DG-8053-1 R160	C-CARBON R	RN72K1J-104JE	4723-104J-P-R	1
DG-8053-1 R161	C-CARBON R	RN72K1J-750JE	4723-750J-P-R	1
DG-8053-1 R164	C-CARBON R	RN72K1J-180JE	4723-180J-P-R	1
DG-8053-1 R165	C-CARBON R	RN72K1J-010JE	4723-1R0J-P-R	1
DG-8053-1 R201	C-CARBON R	RN72K1J-103JE	4723-103J-P-R	1
DG-8053-1 R202	C-CARBON R	RN72K1J-473JE	4723-473J-P-R	1
DG-8053-1 R203	C-CARBON R	RN72K1J-473JE	4723-473J-P-R	1
DG-8053-1 R204	C-CARBON R	RN72K1J-104JE	4723-104J-P-R	1
DG-8053-1 R205	C-CARBON R	RN72K1J-103JE	4723-103J-P-R	1
DG-8053-1 R206	C-CARBON R	RN72K1J-473JE	4723-473J-P-R	1
DG-8053-1 R207	C-CARBON R	RN72K1J-473JE	4723-473J-P-R	1
DG-8053-1 R208	C-CARBON R	RN72K1J-473JE	4723-473J-P-R	1
DG-8053-1 R209	C-CARBON R	RN72K1J-183JE	4723-183J-P-R	1
DG-8053-1 R210	C-CARBON R	RN72K1J-183JE	4723-183J-P-R	1
DG-8053-1 R211	C-CARBON R	RN72K1J-683JE	4723-683J-P-R	1
DG-8053-1 R212	C-CARBON R	RN72K1J-683JE	4723-683J-P-R	1
DG-8053-1 R213	C-CARBON R	RN72K1J-822JE	4723-822J-P-R	1
DG-8053-1 R214	C-CARBON R	RN72K1J-822JE	4723-822J-P-R	1
DIS-8054-1 R301	C-CARBON R	RN72K1J-152JE	4723-152J-P-R	1
DIS-8054-1 R302	C-CARBON R	RN72K1J-152JE	4723-152J-P-R	1
DIS-8054-1 R303	C-CARBON R	RN72K1J-103JE	4723-103J-P-R	1
DIS-8054-1 R304	C-CARBON R	RN72K1J-103JE	4723-103J-P-R	1



DIS-8054-1 R306	C-CARBON R	RN72K1J-103JE	4723-103J-P-R	1
DIS-8054-1 R307	C-CARBON R	RN72K1J-152JE	4723-152J-P-R	15/23 PAGE
DIS-8054-1 R308	C-CARBON R	RN72K1J-152JE	4723-152J-P-R	1
DIS-8054-1 R309	C-CARBON R	RN72K1J-223JE	4723-223J-P-R	1
DIS-8054-1 R310	C-CARBON R	RN72K1J-223JE	4723-223J-P-R	1
DIS-8054-1 R311	C-CARBON R	RN72K1J-223JE	4723-223J-P-R	1
DIS-8054-1 R312	C-CARBON R	RN72K1J-223JE	4723-223J-P-R	1
DIS-8054-1 R313	C-CARBON R	RN72K1J-223JE	4723-223J-P-R	1
DIS-8054-1 R314	C-CARBON R	RN72K1J-223JE	4723-223J-P-R	1
DIS-8054-1 R315	C-CARBON R	RN72K1J-152JE	4723-152J-P-R	1
DIS-8054-1 R316	C-CARBON R	RN72K1J-152JE	4723-152J-P-R	1
DIS-8054-1 R317	C-CARBON R	RN72K1J-152JE	4723-152J-P-R	1
DIS-8054-1 R318	C-CARBON R	RN72K1J-152JE	4723-152J-P-R	1
DIS-8054-1 R319	C-CARBON R	RN72K1J-223JE	4723-223J-P-R	1
DIS-8054-1 R320	C-CARBON R	RN72K1J-223JE	4723-223J-P-R	1
DIS-8054-1 R321	C-CARBON R	RN72K1J-474JE	4723-474J-P-R	1
DIS-8054-1 R322	C-CARBON R	RN72K1J-474JE	4723-474J-P-R	1
DIS-8054-1 R323	C-CARBON R	RN72K1J-471JE	4723-471J-P-R	1
DIS-8054-1 R324	C-CARBON R	RN72K1J-471JE	4723-471J-P-R	1
DIS-8054-1 R325	C-CARBON R	RN72K1J-102JE	4723-102J-P-R	1
DIS-8054-1 R326	C-CARBON R	RN72K1J-102JE	4723-102J-P-R	1
DIS-8054-1 R327	C-CARBON R	RN72K1J-474JE	4723-474J-P-R	1
DIS-8054-1 R328	C-CARBON R	RN72K1J-474JE	4723-474J-P-R	1
DIS-8054-1 R329	C-CARBON R	RN72K1J-102JE	4723-102J-P-R	1
DIS-8054-1 R330	METAL O R	RS1/2WBJ-120	4717-121J-K-X	1
DIS-8054-1 R331	METAL O R	RS1/2WBJ-120	4717-121J-K-X	1
DIS-8054-1 R332	C-CARBON R	RN72K1J-102JE	4723-102J-P-R	1
DIS-8054-1 R333	C-CARBON R	RN72K1J-102JE	4723-102J-P-R	1
DIS-8054-1 R334	C-CARBON R	RN72K1J-103JE	4723-103J-P-R	1
DIS-8054-1 R335	C-CARBON R	RN72K1J-000JE	4723-000J-P-R	1
DIS-8054-1 R336	C-CARBON R	RN72K1J-000JE	4723-000J-P-R	1
DIS-8054-1 R341	C-CARBON R	RN72K1J-474JE	4723-474J-P-R	1
DIS-8054-1 R342	C-CARBON R	RN72K1J-474JE	4723-474J-P-R	1
DG-8053-1 R501	C-CARBON R	RN72K1J-471JE	4723-471J-P-R	1
DG-8053-1 R502	C-CARBON R	RN72K1J-471JE	4723-471J-P-R	1
DG-8053-1 R503	C-CARBON R	RN72K1J-471JE	4723-471J-P-R	1
DG-8053-1 R504	C-CARBON R	RN72K1J-471JE	4723-471J-P-R	1
DG-8053-1 R505	C-CARBON R	RN72K1J-471JE	4723-471J-P-R	1
DG-8053-1 R506	C-CARBON R	RN72K1J-471JE	4723-471J-P-R	1
DG-8053-1 R507	C-CARBON R	RN72K1J-471JE	4723-471J-P-R	1
DG-8053-1 R508	C-CARBON R	RN72K1J-471JE	4723-471J-P-R	1
DG-8053-1 R509	C-CARBON R	RN72K1J-332JE	4723-332J-P-R	1
DG-8053-1 R510	C-CARBON R	RN72K1J-202JE	4723-202J-P-R	1
DG-8053-1 R511	C-CARBON R	RN72K1J-151JE	4723-151J-P-R	1
DG-8053-1 R512	C-CARBON R	RN72K1J-102JE	4723-102J-P-R	1
DG-8053-1 R513	C-CARBON R	RN72K1J-222JE	4723-222J-P-R	1
DG-8053-1 R514	C-CARBON R	RN72K1J-222JE	4723-222J-P-R	1
DG-8053-1 R515	C-CARBON R	RN72K1J-471JE	4723-471J-P-R	1
DG-8053-1 R516	C-CARBON R	RN72K1J-471JE	4723-471J-P-R	1
DG-8053-1 R517	C-CARBON R	RN72K1J-471JE	4723-471J-P-R	1
DG-8053-1 R518	C-CARBON R	RN72K1J-471JE	4723-471J-P-R	1
DG-8053-1 R519	C-CARBON R	RN72K1J-000JE	4723-000J-P-R	1
DG-8053-1 R520	C-CARBON R	RN72K1J-000JE	4723-000J-P-R	1
DG-8053-1 R521	C-CARBON R	RN72K1J-000JE	4723-000J-P-R	1
DG-8053-1 R522	C-CARBON R	RN72K1J-000JE	4723-000J-P-R	1
DG-8053-1 R523	C-CARBON R	RN72K1J-000JE	4723-000J-P-R	1
DG-8053-1 R524	C-CARBON R	RN72K1J-000JE	4723-000J-P-R	1
DG-8053-1 R525	C-CARBON R	RN72K1J-000JE	4723-000J-P-R	1
DG-8053-1 R526	C-CARBON R	RN72K1J-000JE	4723-000J-P-R	1



DG-8053-1 R528	C-CARBON R	RN72K1J-000JE	4723-000J-P-R	1
DG-8053-1 R529	C-CARBON R	RN72K1J-000JE	4723-000J-P-R	17/23 PAGE
DG-8053-1 R530	C-CARBON R	RN72K1J-000JE	4723-000J-P-R	1
DG-8053-1 R531	C-CARBON R	RN72K1J-000JE	4723-000J-P-R	1
DG-8053-1 R532	C-CARBON R	RN72K1J-000JE	4723-000J-P-R	1
DG-8053-1 R533	C-CARBON R	RN72K1J-000JE	4723-000J-P-R	1
DG-8053-1 R534	C-CARBON R	RN72K1J-000JE	4723-000J-P-R	1
DG-8053-1 R535	C-CARBON R	RN72K1J-000JE	4723-000J-P-R	1
DG-8053-1 R536	C-CARBON R	RN72K1J-000JE	4723-000J-P-R	1
DG-8053-1 R537	C-CARBON R	RN72K1J-000JE	4723-000J-P-R	1
DG-8053-1 R538	C-CARBON R	RN72K1J-000JE	4723-000J-P-R	1
DG-8053-1 R539	C-CARBON R	RN72K1J-000JE	4723-000J-P-R	1
DG-8053-1 R540	C-CARBON R	RN72K1J-000JE	4723-000J-P-R	1
DG-8053-1 R541	C-CARBON R	RN72K1J-000JE	4723-000J-P-R	1
DG-8053-1 R542	C-CARBON R	RN72K1J-000JE	4723-000J-P-R	1
DG-8053-1 R543	C-CARBON R	RN72K1J-000JE	4723-000J-P-R	1
DG-8053-1 R544	C-CARBON R	RN72K1J-000JE	4723-000J-P-R	1
DG-8053-1 R545	C-CARBON R	RN72K1J-000JE	4723-000J-P-R	1
DG-8053-1 R546	C-CARBON R	RN72K1J-000JE	4723-000J-P-R	1
DG-8053-1 R547	C-CARBON R	RN72K1J-000JE	4723-000J-P-R	1
DG-8053-1 R548	C-CARBON R	RN72K1J-000JE	4723-000J-P-R	1
DG-8053-1 R549	C-CARBON R	RN72K1J-000JE	4723-000J-P-R	1
DG-8053-1 R550	C-CARBON R	RN72K1J-000JE	4723-000J-P-R	1
DG-8053-1 R551	C-CARBON R	RN72K1J-471JE	4723-471J-P-R	1
DG-8053-1 R552	C-CARBON R	RN72K1J-000JE	4723-000J-P-R	1
DG-8053-1 R555	C-CARBON R	RN72K1J-471JE	4723-471J-P-R	1
DG-8053-1 R556	C-CARBON R	RN72K1J-103JE	4723-103J-P-R	1
DG-8053-1 R557	C-CARBON R	RN72K1J-103JE	4723-103J-P-R	1
DG-8053-1 R558	C-CARBON R	RN72K1J-222JE	4723-222J-P-R	1
DG-8053-1 R559	C-CARBON R	RN72K1J-000JE	4723-000J-P-R	1
DG-8053-1 R560	C-CARBON R	RN72K1J-471JE	4723-471J-P-R	1
DG-8053-1 R561	C-CARBON R	RN72K1J-471JE	4723-471J-P-R	1
DIS-8054-1 R601	C-CARBON R	RN72K1J-104JE	4723-104J-P-R	1
DIS-8054-1 R602	C-CARBON R	RN72K1J-104JE	4723-104J-P-R	1
DIS-8054-1 R603	C-CARBON R	RN72K1J-222JE	4723-222J-P-R	1
DIS-8054-1 R604	NF CARBON R	R25J-4.7	4705-4R7J-K-P	1
DIS-8054-1 R605	C-CARBON R	RN72K1J-104JE	4723-104J-P-R	1
DIS-8054-1 R606	C-CARBON R	RN72K1J-104JE	4723-104J-P-R	1
DIS-8054-1 R607	C-CARBON R	RN72K1J-000JE	4723-000J-P-R	1
DIS-8054-1 R609	C-CARBON R	RN72K1J-221JE	4723-221J-P-R	1
DIS-8054-1 R610	C-CARBON R	RN72K1J-223JE	4723-223J-P-R	1
DIS-8054-1 R611	C-CARBON R	RN72K1J-562JE	4723-562J-P-R	1
DIS-8054-1 R612	C-CARBON R	RN72K1J-103JE	4723-103J-P-R	1
DIS-8054-1 R613	NF CARBON R	R25J-4.7	4705-4R7J-K-P	1
DIS-8054-1 R614	C-CARBON R	RN72K1J-103JE	4723-103J-P-R	1
DIS-8054-1 R615	C-CARBON R	RN72K1J-103JE	4723-103J-P-R	1
DIS-8054-1 R616	C-CARBON R	RN72K1J-103JE	4723-103J-P-R	1
DIS-8054-1 R617	C-CARBON R	RN72K1J-103JE	4723-103J-P-R	1
DIS-8054-1 R618	C-CARBON R	RN72K1J-332JE	4723-332J-P-R	1
DIS-8054-1 R619	C-CARBON R	RN72K1J-274JE	4723-274J-P-R	1
DIS-8054-1 R620	C-CARBON R	RN72K1J-105JE	4723-105J-P-R	1
DIS-8054-1 R621	C-CARBON R	RN72K1J-822JE	4723-822J-P-R	1
DIS-8054-1 R622	C-CARBON R	RN72K1J-103JE	4723-103J-P-R	1
DIS-8054-1 R623	C-CARBON R	RN72K1J-562JE	4723-562J-P-R	1
DIS-8054-1 R624	C-CARBON R	RN72K1J-822JE	4723-822J-P-R	1
DIS-8054-1 R625	C-CARBON R	RN72K1J-105JE	4723-105J-P-R	1
DIS-8054-1 R626	C-CARBON R	RN72K1J-472JE	4723-472J-P-R	1
DIS-8054-1 R627	C-CARBON R	RN72K1J-222JE	4723-222J-P-R	1
DIS-8054-1 R628	C-CARBON R	RN72K1J-000JE	4723-000J-P-R	1





DIS-8054-1 R652	C-CARBON R	RN72K1J-154JE	4723-154J-P-R	1
DIS-8054-1 R653	C-CARBON R	RN72K1J-331JE	4723-331J-P-R	19/23 PAGE
DIS-8054-1 R654	C-CARBON R	RN72K1J-474JE	4723-474J-P-R	1
DIS-8054-1 R655	C-CARBON R	RN72K1J-000JE	4723-000J-P-R	1
DIS-8054-1 R656	C-CARBON R	RN72K1J-000JE	4723-000J-P-R	1
DG-8053-1 R701	C-CARBON R	RN72K1J-331JE	4723-331J-P-R	1
DG-8053-1 R702	C-CARBON R	RN72K1J-331JE	4723-331J-P-R	1
DG-8053-1 R703	C-CARBON R	RN72K1J-102JE	4723-102J-P-R	1
DG-8053-1 R704	C-CARBON R	RN72K1J-473JE	4723-473J-P-R	1
DG-8053-1 R705	C-CARBON R	RN72K1J-104JE	4723-104J-P-R	1
DG-8053-1 R706	C-CARBON R	RN72K1J-102JE	4723-102J-P-R	1
DG-8053-1 R707	C-CARBON R	RN72K1J-122JE	4723-122J-P-R	1
DG-8053-1 R708	C-CARBON R	RN72K1J-102JE	4723-102J-P-R	1
DG-8053-1 R709	C-CARBON R	RN72K1J-471JE	4723-471J-P-R	1
DG-8053-1 R710	C-CARBON R	RN72K1J-681JE	4723-681J-P-R	1
DG-8053-1 R711	C-CARBON R	RN72K1J-471JE	4723-471J-P-R	1
DG-8053-1 R712	C-CARBON R	RN72K1J-102JE	4723-102J-P-R	1
DG-8053-1 R713	C-CARBON R	RN72K1J-102JE	4723-102J-P-R	1
DG-8053-1 R714	C-CARBON R	RN72K1J-122JE	4723-122J-P-R	1
DG-8053-1 R715	C-CARBON R	RN72K1J-471JE	4723-471J-P-R	1
DG-8053-1 R716	C-CARBON R	RN72K1J-223JE	4723-223J-P-R	1
DG-8053-1 R717	C-CARBON R	RN72K1J-000JE	4723-000J-P-R	1
DG-8053-1 R718	C-CARBON R	RN72K1J-000JE	4723-000J-P-R	1
DG-8053-1 R719	C-CARBON R	RN72K1J-000JE	4723-000J-P-R	1
DG-8053-1 R721	C-CARBON R	RN72K1J-103JE	4723-103J-P-R	1
DG-8053-1 R722	C-CARBON R	RN72K1J-000JE	4723-000J-P-R	1
DG-8053-1 R723	C-CARBON R	RN72K1J-103JE	4723-103J-P-R	1
DG-8053-1 R724	C-CARBON R	RN72K1J-474JE	4723-474J-P-R	1
DG-8053-1 R725	C-CARBON R	RN72K1J-000JE	4723-000J-P-R	1
DG-8053-1 R726	C-CARBON R	RN72K1J-471JE	4723-471J-P-R	1
DG-8053-1 R727	C-CARBON R	RN72K1J-471JE	4723-471J-P-R	1
DG-8053-1 R728	C-CARBON R	RN72K1J-471JE	4723-471J-P-R	1
DG-8053-1 R729	C-CARBON R	RN72K1J-471JE	4723-471J-P-R	1
DG-8053-1 R730	C-CARBON R	RN72K1J-471JE	4723-471J-P-R	1
DG-8053-1 R731	C-CARBON R	RN72K1J-471JE	4723-471J-P-R	1
DG-8053-1 R732	C-CARBON R	RN72K1J-122JE	4723-122J-P-R	1
DG-8053-1 R733	C-CARBON R	RN72K1J-471JE	4723-471J-P-R	1
DG-8053-1 R734	C-CARBON R	RN72K1J-471JE	4723-471J-P-R	1
DG-8053-1 R735	C-CARBON R	RN72K1J-471JE	4723-471J-P-R	1
DG-8053-1 R736	C-CARBON R	RN72K1J-471JE	4723-471J-P-R	1
DG-8053-1 R737	C-CARBON R	RN72K1J-471JE	4723-471J-P-R	1
DG-8053-1 R738	C-CARBON R	RN72K1J-471JE	4723-471J-P-R	1
DG-8053-1 R739	C-CARBON R	RN72K1J-471JE	4723-471J-P-R	1
DG-8053-1 R740	C-CARBON R	RN72K1J-471JE	4723-471J-P-R	1
DG-8053-1 R741	C-CARBON R	RN72K1J-471JE	4723-471J-P-R	1
DG-8053-1 R742	C-CARBON R	RN72K1J-471JE	4723-471J-P-R	1
DG-8053-1 R743	C-CARBON R	RN72K1J-122JE	4723-122J-P-R	1
DG-8053-1 R744	C-CARBON R	RN72K1J-122JE	4723-122J-P-R	1
DG-8053-1 R745	C-CARBON R	RN72K1J-000JE	4723-000J-P-R	1
DG-8053-1 R746	C-CARBON R	RN72K1J-103JE	4723-103J-P-R	1
DG-8053-1 R747	C-CARBON R	RN72K1J-102JE	4723-102J-P-R	1
DG-8053-1 R748	C-CARBON R	RN72K1J-331JE	4723-331J-P-R	1
DG-8053-1 R749	C-CARBON R	RN72K1J-473JE	4723-473J-P-R	1
DG-8053-1 R750	C-CARBON R	RN72K1J-473JE	4723-473J-P-R	1
DG-8053-1 R751	C-CARBON R	RN72K1J-473JE	4723-473J-P-R	1
DG-8053-1 R752	C-CARBON R	RN72K1J-222JE	4723-222J-P-R	1
DG-8053-1 R753	C-CARBON R	RN72K1J-122JE	4723-122J-P-R	1
DG-8053-1 R754	C-CARBON R	RN72K1J-000JE	4723-000J-P-R	1
DG-8053-1 R755	C-CARBON R	RN72K1J-000JE	4723-000J-P-R	1



DG-8053-1 R757	C-CARBON R	RN72K1J-000JE	4723-000J-P-R	1
DG-8053-1 R758	C-CARBON R	RN72K1J-000JE	4723-000J-P-R	21/23 PAGE
DG-8053-1 R759	C-CARBON R	RN72K1J-000JE	4723-000J-P-R	1
DG-8053-1 R760	C-CARBON R	RN72K1J-000JE	4723-000J-P-R	1
DG-8053-1 R762	C-CARBON R	RN72K1J-000JE	4723-000J-P-R	1
DG-8053-1 R763	C-CARBON R	RN72K1J-000JE	4723-000J-P-R	1
DG-8053-1 R764	C-CARBON R	RN72K1J-103JE	4723-103J-P-R	1
DG-8053-1 R765	C-CARBON R	RN72K1J-000JE	4723-000J-P-R	1
DG-8053-1 R766	C-CARBON R	RN72K1J-473JE	4723-473J-P-R	1
DG-8053-1 R767	C-CARBON R	RN72K1J-473JE	4723-473J-P-R	1
DG-8053-1 R768	C-CARBON R	RN72K1J-473JE	4723-473J-P-R	1
DG-8053-1 R769	C-CARBON R	RN72K1J-332JE	4723-332J-P-R	1
DG-8053-1 R770	C-CARBON R	RN72K1J-103JE	4723-103J-P-R	1
DG-8053-1 R771	C-CARBON R	RN72K1J-103JE	4723-103J-P-R	1
DG-8053-1 R772	C-CARBON R	RN72K1J-103JE	4723-103J-P-R	1
DIS-8054-1 R801	C-CARBON R	RN72K1J-103JE	4723-103J-P-R	1
DIS-8054-1 R802	C-CARBON R	RN72K1J-331JE	4723-331J-P-R	1
DIS-8054-1 R803	C-CARBON R	RN72K1J-331JE	4723-331J-P-R	1
DIS-8054-1 R804	C-CARBON R	RN72K1J-471JE	4723-471J-P-R	1
DIS-8054-1 R805	C-CARBON R	RN72K1J-681JE	4723-681J-P-R	1
DIS-8054-1 R806	C-CARBON R	RN72K1J-560JE	4723-560J-P-R	1
DIS-8054-1 R807	C-CARBON R	RN72K1J-272JE	4723-272J-P-R	1
DIS-8054-1 R808	C-CARBON R	RN72K1J-391JE	4723-391J-P-R	1
DIS-8054-1 R809	C-CARBON R	RN72K1J-471JE	4723-471J-P-R	1
DIS-8054-1 R810	C-CARBON R	RN72K1J-821JE	4723-821J-P-R	1
DIS-8054-1 R811	C-CARBON R	RN72K1J-102JE	4723-102J-P-R	1
DIS-8054-1 R812	C-CARBON R	RN72K1J-182JE	4723-182J-P-R	1
DIS-8054-1 R813	C-CARBON R	RN72K1J-391JE	4723-391J-P-R	1
DIS-8054-1 R814	C-CARBON R	RN72K1J-471JE	4723-471J-P-R	1
DIS-8054-1 R815	C-CARBON R	RN72K1J-821JE	4723-821J-P-R	1
DIS-8054-1 R816	C-CARBON R	RN72K1J-102JE	4723-102J-P-R	1
DIS-8054-1 R817	C-CARBON R	RN72K1J-182JE	4723-182J-P-R	1
DIS-8054-1 R818	C-CARBON R	RN72K1J-392JE	4723-392J-P-R	1
DIS-8054-1 R819	C-CARBON R	RN72K1J-392JE	4723-392J-P-R	1
DIS-8054-1 R820	C-CARBON R	RN72K1J-560JE	4723-560J-P-R	1
DIS-8054-1 R821	C-CARBON R	RN72K1J-560JE	4723-560J-P-R	1
DIS-8054-1 R822	C-CARBON R	RN72K1J-391JE	4723-391J-P-R	1
DIS-8054-1 R823	C-CARBON R	RN72K1J-471JE	4723-471J-P-R	1
DIS-8054-1 R824	C-CARBON R	RN72K1J-821JE	4723-821J-P-R	1
DIS-8054-1 R825	C-CARBON R	RN72K1J-102JE	4723-102J-P-R	1
DIS-8054-1 R826	C-CARBON R	RN72K1J-272JE	4723-272J-P-R	1
DIS-8054-1 R827	C-CARBON R	RN72K1J-272JE	4723-272J-P-R	1
DIS-8054-1 R828	C-CARBON R	RN72K1J-272JE	4723-272J-P-R	1
DIS-8054-1 R829	C-CARBON R	RN72K1J-471JE	4723-471J-P-R	1
DIS-8054-1 R830	C-CARBON R	RN72K1J-471JE	4723-471J-P-R	1
DIS-8054-1 R831	C-CARBON R	RN72K1J-223JE	4723-223J-P-R	1
DIS-8054-1 R832	C-CARBON R	RN72K1J-223JE	4723-223J-P-R	1
DIS-8054-1 R834	C-CARBON R	RN72K1J-101JE	4723-101J-P-R	1
DIS-8054-1 R835	C-CARBON R	RN72K1J-101JE	4723-101J-P-R	1
DIS-8054-1 R836	C-CARBON R	RN72K1J-104JE	4723-104J-P-R	1
DIS-8054-1 R837	C-CARBON R	RN72K1J-000JE	4723-000J-P-R	1
DIS-8054-1 R851	C-CARBON R	RN72K1J-470JE	4723-470J-P-R	1
DIS-8054-1 R852	C-CARBON R	RN72K1J-470JE	4723-470J-P-R	1
DIS-8054-1 R853	C-CARBON R	RN72K1J-101JE	4723-101J-P-R	1
DIS-8054-1 R854	C-CARBON R	RN72K1J-000JE	4723-000J-P-R	1
DIS-8054-1 R855	C-CARBON R	RN72K1J-000JE	4723-000J-P-R	1
DIS-8054-1 R856	C-CARBON R	RN72K1J-101JE	4723-101J-P-R	1
DIS-8054-1 R857	C-CARBON R	RN72K1J-103JE	4723-103J-P-R	1
DIS-8054-1 R858	C-CARBON R	RN72K1J-103JE	4723-103J-P-R	1



DIS-8054-1 R860	C-CARBON R	RN72K1J-103JE	4723-103J-P-R	1
DIS-8054-1 R862	C-CARBON R	RN72K1J-101JE	4723-101J-P-R	23/23 PAGE
DIS-8054-1 R864	C-CARBON R	RN72K1J-103JE	4723-103J-P-R	1
DIS-8054-1 R865	C-CARBON R	RN72K1J-103JE	4723-103J-P-R	1
DIS-8054-1 R867	C-CARBON R	RN72K1J-000JE	4723-000J-P-R	1
DIS-8054-1 R868	C-CARBON R	RN72K1J-103JE	4723-103J-P-R	1
DIS-8054-1 R888	C-CARBON R	RN72K1J-104JE	4723-104J-P-R	1
DIS-8054-1 R889	C-CARBON R	RN72K1J-104JE	4723-104J-P-R	1
DIS-8054-1 R890	C-CARBON R	RN72K1J-104JE	4723-104J-P-R	1
DIS-8054-1 R891	C-CARBON R	RN72K1J-104JE	4723-104J-P-R	1
DIS-8054-1 R892	C-CARBON R	RN72K1J-104JE	4723-104J-P-R	1
DIS-8054-1 R893	C-CARBON R	RN72K1J-104JE	4723-104J-P-R	1
DIS-8054-1 R894	C-CARBON R	RN72K1J-104JE	4723-104J-P-R	1
DIS-8054-1 R895	C-CARBON R	RN72K1J-104JE	4723-104J-P-R	1
DIS-8054-1 R896	C-CARBON R	RN72K1J-104JE	4723-104J-P-R	1
DIS-8054-1 R897	C-CARBON R	RN72K1J-104JE	4723-104J-P-R	1
DIS-8054-1 R898	C-CARBON R	RN72K1J-104JE	4723-104J-P-R	1
DIS-8054-1 R899	C-CARBON R	RN72K1J-000JE	4723-000J-P-R	1
DIS-8054-1 R901	C-CARBON R	RN72K1J-332JE	4723-332J-P-R	1
DIS-8054-1 R902	C-CARBON R	RN72K1J-391JE	4723-391J-P-R	1
DIS-8054-1 R903	C-CARBON R	RN72K1J-391JE	4723-391J-P-R	1
DIS-8054-1 R904	C-CARBON R	RN72K1J-471JE	4723-471J-P-R	1
DIS-8054-1 R905	C-CARBON R	RN72K1J-332JE	4723-332J-P-R	1
DIS-8054-1 R907	C-CARBON R	RN72K1J-223JE	4723-223J-P-R	1
DIS-8054-1 R908	C-CARBON R	RN72K1J-391JE	4723-391J-P-R	1
DIS-8054-1 S601	PUSH SW	NPS-111-S679	5200-4862-0-01	1
DIS-8054-1 S602	PUSH SW	NPS-111-S679	5200-4862-0-01	1
DIS-8054-1 S603	PUSH SW	NPS-111-S679	5200-4862-0-01	1
DIS-8054-1 S801	PUSH SW	NPS-111-S681	5200-4861-0-01	1
DIS-8054-1 S802	PUSH SW	NPS-111-S681	5200-4861-0-01	1
DIS-8054-1 S803	PUSH SW	NPS-111-S681	5200-4861-0-01	1
DIS-8054-1 S804	PUSH SW	NPS-111-S681	5200-4861-0-01	1
DIS-8054-1 S805	PUSH SW	NPS-111-S681	5200-4861-0-01	1
DIS-8054-1 S806	PUSH SW	NPS-111-S681	5200-4861-0-01	1
DIS-8054-1 S807	PUSH SW	NPS-111-S681	5200-4861-0-01	1
DIS-8054-1 S808	PUSH SW	NPS-111-S681	5200-4861-0-01	1
DIS-8054-1 S809	PUSH SW	NPS-111-S681	5200-4861-0-01	1
DIS-8054-1 S810	PUSH SW	NPS-111-S681	5200-4861-0-01	1
DIS-8054-1 S811	PUSH SW	NPS-111-S681	5200-4861-0-01	1
DIS-8054-1 S812	PUSH SW	NPS-111-S681	5200-4861-0-01	1
DIS-8054-1 S813	PUSH SW	NPS-111-S681	5200-4861-0-01	1
DIS-8054-1 S814	PUSH SW	NPS-111-S681	5200-4861-0-01	1
DIS-8054-1 S815	PUSH SW	NPS-111-S681	5200-4861-0-01	1
DIS-8054-1 S816	PUSH SW	NPS-111-S681	5200-4861-0-01	1
DIS-8054-1 S817	PUSH SW	NPS-111-S681	5200-4861-0-01	1
DIS-8054-1 S818	PUSH SW	NPS-111-S681	5200-4861-0-01	1
DIS-8054-1 S819	PUSH SW	NPS-111-S681	5200-4861-0-01	1
DIS-8054-1 T902	CHOKE COIL	NCH-3567	1806-3687-0	1
DG-8053-1 X151	CRYSTAL	HC-49/U03C16.9344MHz	2300-2340-0	N 1
DG-8053-1 X701	CERA LOCK	CSTCE12M5G52-R0	2703-0890-0	1
DIS-8054-1 X801	CERA LOCK	CSTS0500MG06	2703-0880-0	1

---

**ONKYO CORPORATION**

Sales & Product Planning Div. : 2-1, Nisshin-cho, Neyagawa-shi, OSAKA 572-8540, JAPAN  
Tel: 072-831-8023 Fax: 072-831-8124

**ONKYO U.S.A. CORPORATION**

18 Park Way, Upper Saddle River, N.J. 07458, U.S.A.  
Tel: 201-785-2600 Fax: 201-785-2650 <http://www.onkyousa.com>

**ONKYO EUROPE ELECTRONICS GmbH**

Liegnitzerstrasse 6, 82194 Groebenzell, GERMANY  
Tel: +49-8142-4401-0 Fax: +49-8142-4401-555 <http://www.onkyo.net>

**ONKYO EUROPE UK Office**

Suite 1, Gregories Court, Gregories Road, Beaconsfield, Buckinghamshire, HP9 1HQ  
UNITED KINGDOM Tel: +44-(0)1494-681515 Fax: +44(0)-1494-680452

**ONKYO CHINA LIMITED**

Units 2102-2107, Metroplaza Tower I, 223 Hing Fong Road, Kwai Chung,  
N.T., HONG KONG Tel: 852-2429-3118 Fax: 852-2428-9039