

ONKYO® SERVICE MANUAL

COMPACT DISC CHANGER

MODEL DX-C370



Black and Silver models

BMD	120V AC, 60Hz
BMP/BMPA/SMP	230V AC, 50Hz
BMWT	120/220-230V AC, 50/60Hz

SAFETY-RELATED COMPONENT WARNING!!

COMPONENTS IDENTIFIED BY MARK Δ ON THE SCHEMATIC DIAGRAM AND IN THE PARTS LIST ARE CRITICAL FOR RISK OF FIRE AND ELECTRIC SHOCK. REPLACE THESE COMPONENTS WITH ONKYO PARTS WHOSE PARTS NUMBERS APPEAR AS SHOWN IN THIS MANUAL.

MAKE LEAKAGE-CURRENT OR RESISTANCE MEASUREMENTS TO DETERMINE THAT EXPOSED PARTS ARE ACCEPTABLY INSULATED FROM THE SUPPLY CIRCUIT BEFORE RETURNING THE APPLIANCE TO THE CUSTOMER.

SPECIFICATIONS

Signal readout system:	Optical non-contact
Reading rotation:	About 500 - 200 r.p.m. (constant linear velocity)
Linear velocity:	1.2 - 1.4 m/s
Error correction system:	Cross Interleave Reed-Solomon code
D/A converter:	1 bit PWM/ACCUPULSE
Sampling frequency:	352.8 kHz (8 times oversampling)
Number of channels:	2 (stereo)
Frequency response:	5 Hz - 20 kHz
Total harmonic distortion:	0.005% (at 1 kHz)
Dynamic range:	96 dB
Signal to noise ratio:	92 dB
Channel separation:	92 dB (at 1 kHz)
Wow and Flutter:	Below threshold of measurability
Output level:	2 volts r.m.s.
Power consumption:	10 watts
Power supply:	120 V, 60 Hz 230V, 50 Hz 220-230V/120V switchable, 50/60 Hz
Dimensions (W x H x D):	435x 131x 433mm (17-1/8" x 5-3/16" x 17-1/16")
Weight:	6.9 kg (15.2 lbs.)

Specifications and features are subject to change without notice.

ONKYO®
AUDIO COMPONENTS

TABLE OF CONTENTS

Specifications	1
Caution on replacement of optical pick-up	2
Protection of eyes from laser beam during servicing	3
Laser warning label	3
IC block diagrams and descriptions	4
Microprocessor connection diagram	8
Microprocessor terminal description	9
Care should be taken with the optical pickup	10
Trouble shooting	11
Initializing operation	13
Error message displayed in heat-running mode	14
Block diagram	15
Chassis exploded view	17
Parts list	19
Pick-up drive unit view	20
Printed circuit board-parts list	21
Printed circuit board view from bottom side	23
Schematic diagram	27
Adjustment procedures	29
Packing view	30

SERVICE PROCEDURES

1. Safety-check out

After correcting the original service problem, perform the following safety check before releasing the set to the customer:

Connect the insulating-resistance tester between the plug of power supply cord and chassis.

Specifications: More than 10M Ω at 500V.

2. Voltage Selector (Back panel)

Worldwide models are equipped with a voltage selector to conform with local power supplies. Be sure to set this switch to match the voltage of the power supply in user's area before turning the power switch on.

Voltage is changed by sliding the groove in the switch with a screw driver to the right or left.

Confirm that the switch has been moved all the way to the right or left before turning the power switch on.



CAUTION ON REPLACEMENT OF OPTICAL PICK UP

The laser diode in the optical pickup block is so sensitive to static electricity, surge current and etc. that the components are liable to be broken down or its reliability remarkably deteriorated.

During repair, carefully take the following precautions. (The following precautions are included in the service parts.)

PRECAUTIONS

1. Ground for the work-desk.

Place a conductive sheet such as a sheet of copper (with impedance lower than 10M Ω) on the work-desk and place the set on the conductive sheet so that the chassis.

2. Grounding for the test equipment and tools.

Test equipments and toolings should be grounded in order that their ground level is the same the ground of the power source.

3. Grounding for the human body.

Be sure to put on a wrist-strap for grounding whose other end is grounded.

Be particularly careful when the workers wear synthetic fiber clothes, or air is dry.

4. Select a soldering iron that permits no leakage and have the tip of the iron well-grounded.

5. Do not check the laser diode terminals with the probe of a circuit tester or oscilloscope.

PROTECTION OF EYES FROM LASER BEAM DURING SERVICING

This set employs a laser. Therefore, be sure to follow carefully the instructions below when servicing.

WARNING!!

WHEN SERVICING, DO NOT APPROACH THE LASER EXIT WITH THE EYE TOO CLOSELY. IN CASE IT IS NECESSARY TO CONFIRM LASER BEAM EMISSION, BE SURE TO OBSERVE FROM A DISTANCE OF MORE THAN 30cm FROM THE SURFACE OF THE OBJECTIVE LENS ON THE OPTICAL PICK-UP BLOCK.

Laser Diode Properties

- Material: GaAlAs
- Wavelength: 760~800nm
- Emission Duration: continuous
- Laser output: max. 0.5mW*

*This output is the value measured at a distance about 1.8mm from the objective lens surface on the Optical Pick-up Block.

LASER WARNING LABEL

These labels are located on the mechanism.

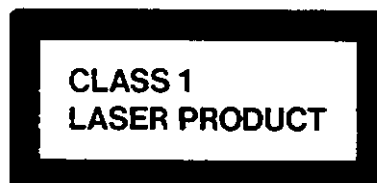
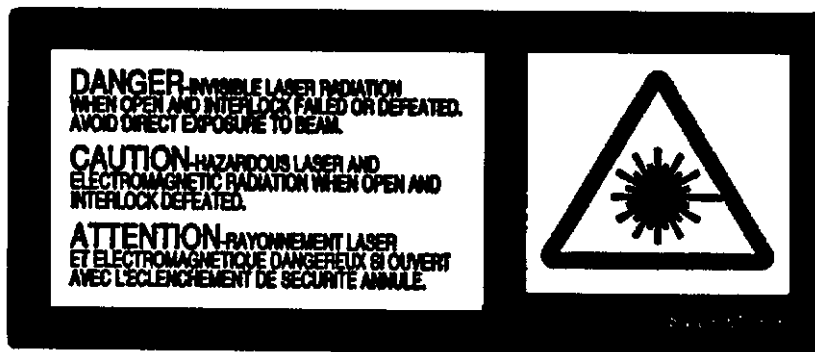
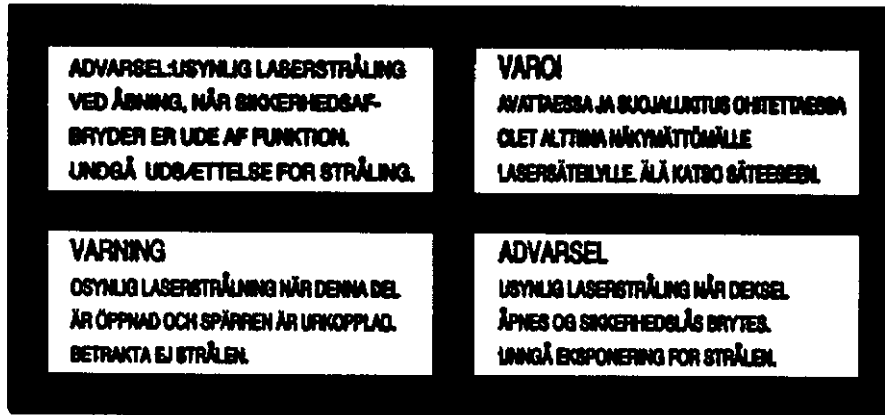

CAUTION ON REPLACEMENT OF OPTICAL PICKUP

The laser diode in the optical pickup block is so sensitive to static electricity, surge current and etc. that the components are liable to be broken down or its reliability remarkably deteriorated.

During repair, carefully take the following precautions.

1. When replacing the optical pickup, first short the LD terminals and remove the connector. Also, when attaching the new optical pickup, after attaching the connector, unsolder the LD terminals.
2. Do not touch the optical pickup object lens with the hands.

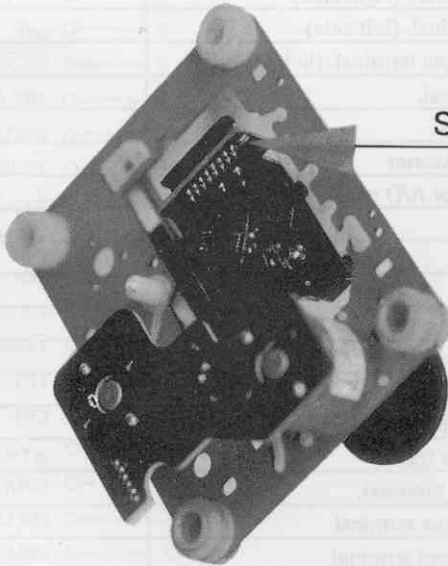

Short pattern for LD protection.

TROUBLE SHOOTING

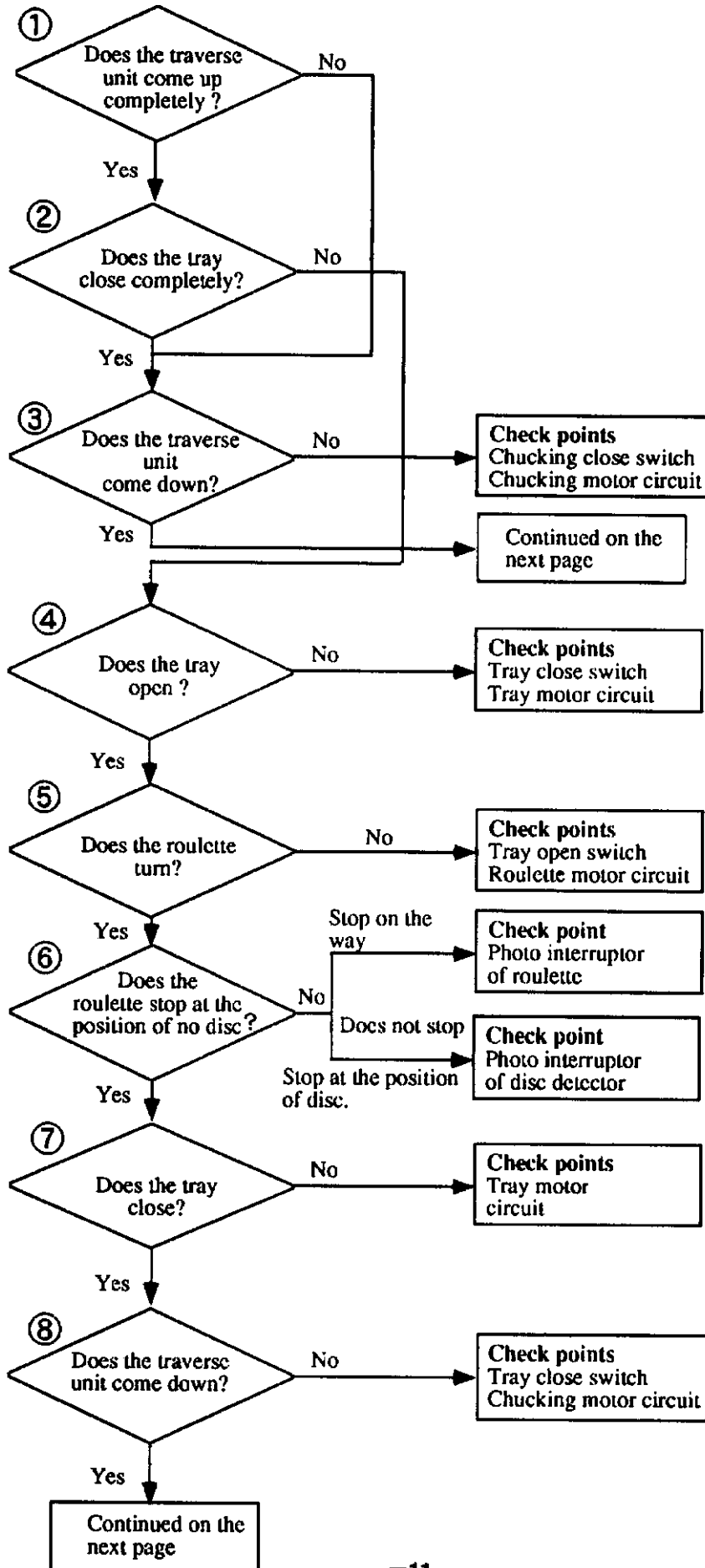

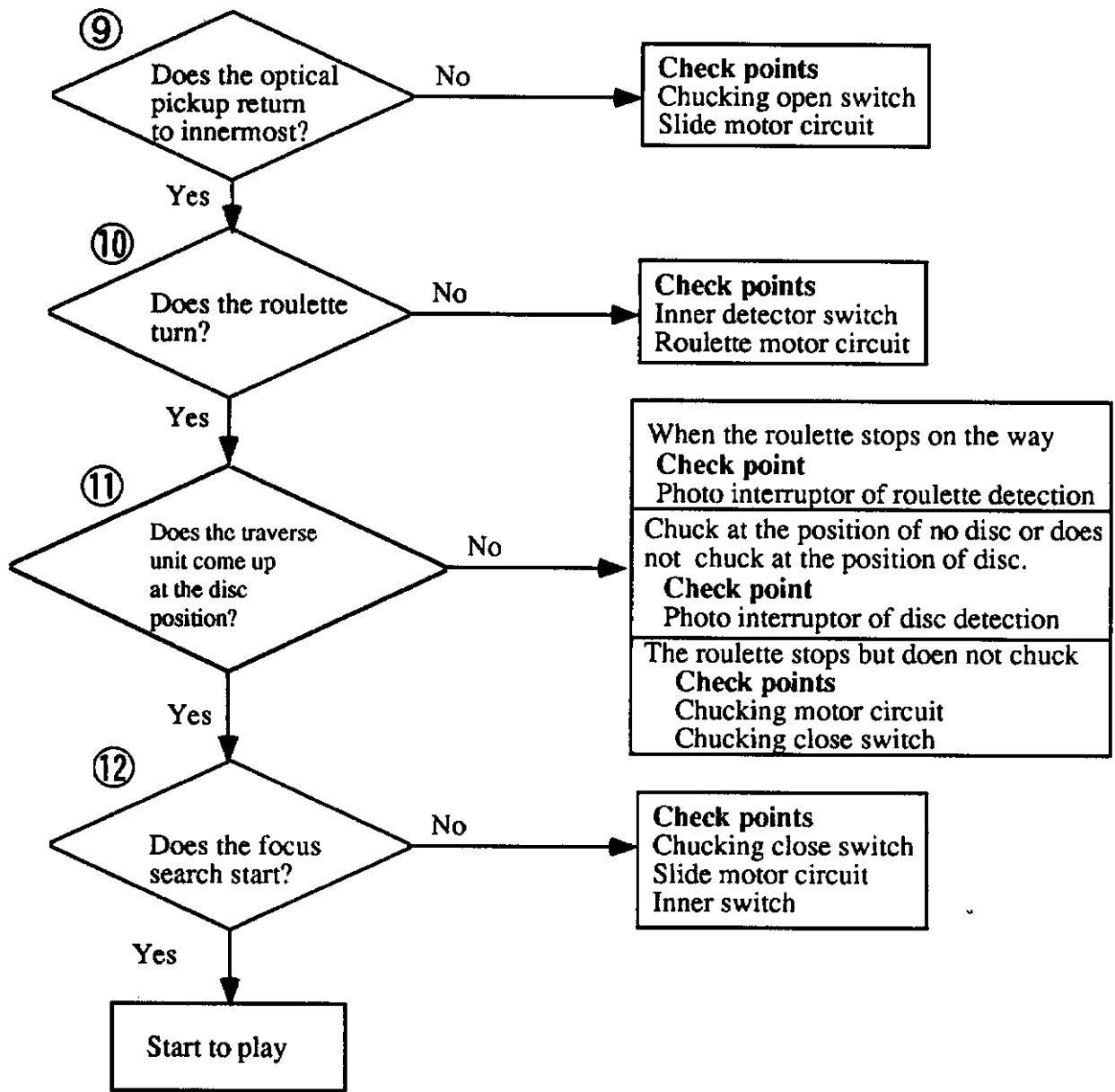

INITIALIZING OPERATION

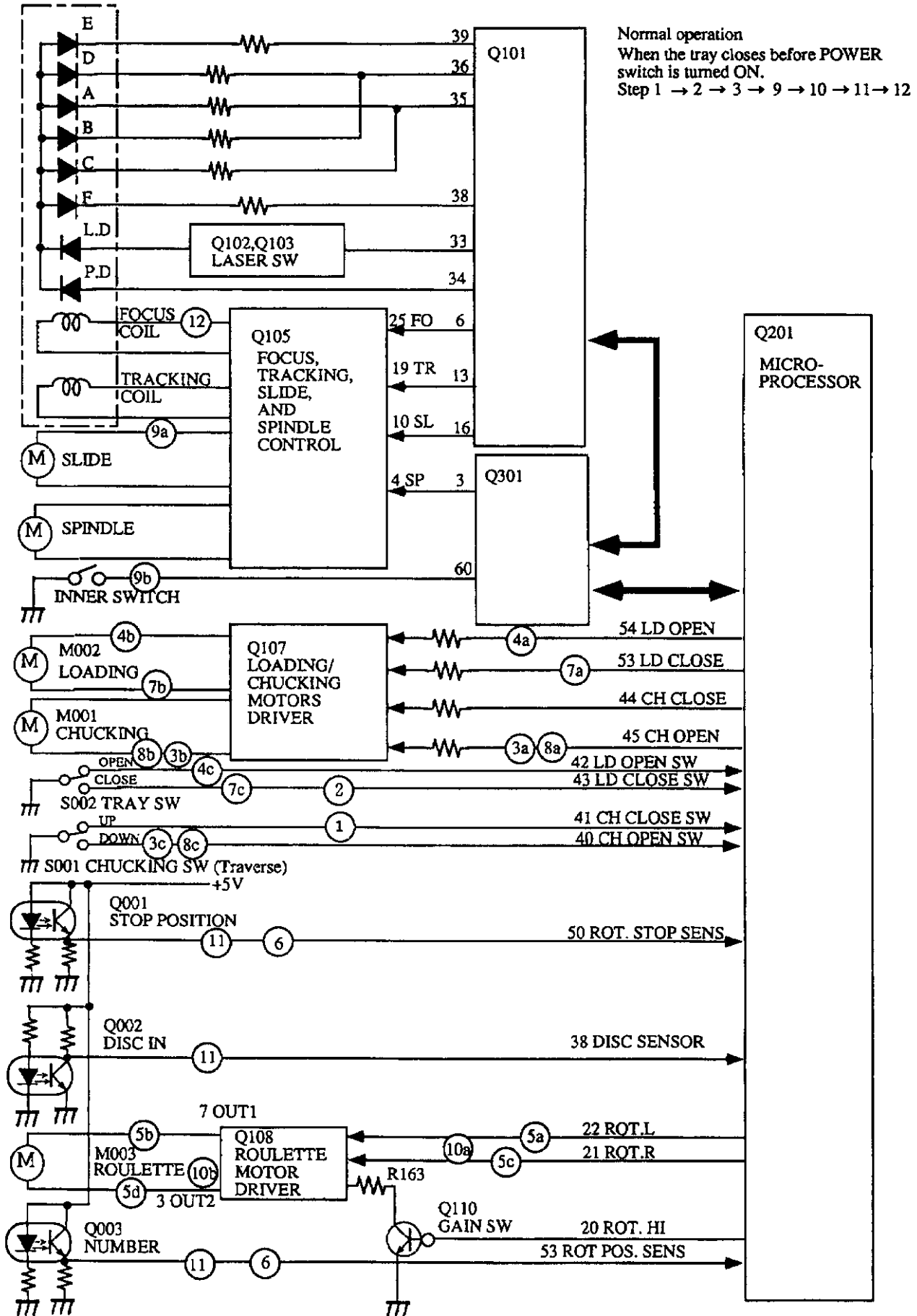

ERROR MESSAGE DISPLAYED IN HEAT-RUNNING MODE

Heat-running Mode : Power ON as pushing DOWN button together.

Operation :

1. DISC 1 chucking and TOC Reading (Pick-up Home position is displayed.)
2. Accessing of the Outermost Track
3. Tray Open
4. Tray Close
5. DISC 1 Playing / Stop and Chucking Down
6. Roulette Turning 7/6 Turns clockwise

Then,

1. DISC 2 chucking and TOC Reading (Pick-up Home position is displayed.)
2. Accessing of the Outermost Track
3. Tray Open
4. Tray Close
5. DISC 2 Playing / Stop and Chucking Down
6. Roulette Turning 5/6 Turns counter-clockwise

Then,

Continued as the above.

In these operation Error Message is shown in the display if any error occurs in the mechanism or the servo control. And then you can find the failure point almost exactly in this mode before you repair rejected units.

1. nf : FOCUS NG : FOCUS SERVO ON missed (Failure in Laser or RF circuit)
2. ng : GFS NG : TIMEOUT for Non-GFS (Synchronous Signal Detection) (Failure in RF Demodulator or CLV)
3. Ld : TOC Reading NG : TIME OUT Before TOC Reading completion (All SERVO Circuit)
4. Ac : ACCESS NG : TIME OUT before ACCESS completion (All SERVO Circuit)
5. co : CH OPEN NG : Non-CHUCKING Open
6. cc : CH CLOSE NG : Non-CHUCKING Close
7. rL : ROT LEFT NG : Non CCW Turning of Roulette or Non-Detection of CCW Turning of Roulette
8. rr : ROT RIGHT NG : Non CW Turning of Roulette or Non-Detection of CW Turning of Roulette
9. OP : TRAY OPEN NG : Non TRAY Open
10. CL : TRAY CLOSE NG : Non TRAY Close
11. PU : PICK UP RETURN NG : PICK-UP Non Return to the inner most.

There are two Errors in the normal operation as follows.

1. Er : INITIALIZE ERROR : Error occurred in Mechanism when it is initialized. (Error points are displayed in Heat-running Mode.)
2. rn : RAM NG : RAM for File is not initialized.

BLOCK DIAGRAM

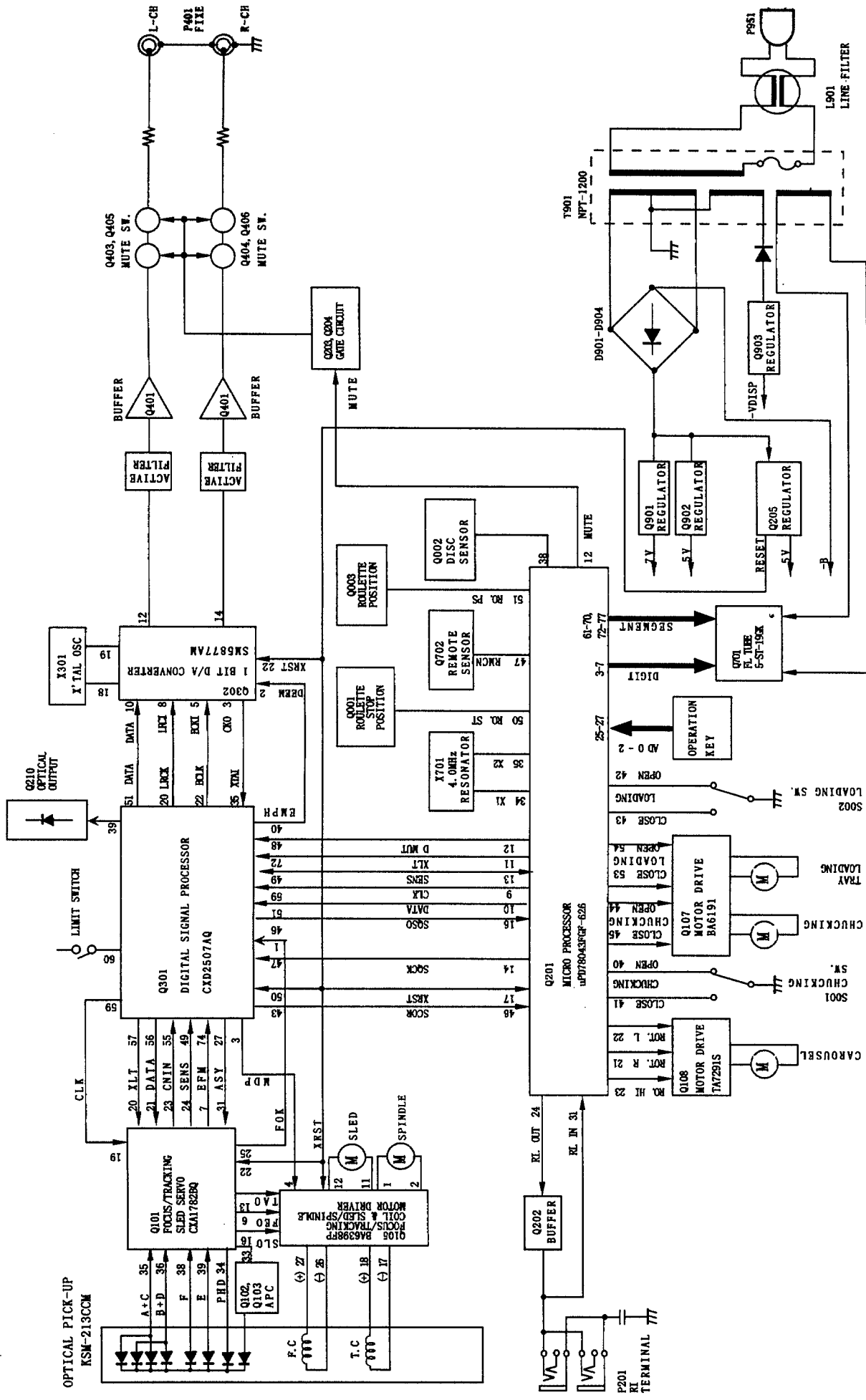

DX-C370

REF.NO.	PART NO.	DESCRIPTION	REF.NO.	PART NO.	DESCRIPTION
A1	27110990A	Front bracket 	U11	1H401554-1	NAETC-5854-1,Position sensor PC board ass'y
	27110991A	Front bracket <S>	U12	1H401555-1	NAETC-5855-1,Chucking motor PC board ass'y
A2	838130088	3TTB+8B,Self-tapping screw	U13	1H401556-1	NAETC-5856-1,Loading motor PC board ass'y
A3	28191776A	Clear plate 	U14	1H401557-1	NASW-5857-1,Chucking switch PC board ass'y
	28191777A	Clear plate <S>	U15	1H401558-1	NASW-5858-1,Roulette position PC board ass'y
A4	28325465	Knob, Power 	U16	1H401559-1	NAETC-5859-1,Disc sensor PC board ass'y
	28325466	Knob, Power <S>	M2	24840109Y	Rail
A5	27100327	Chassis	M3	28141337	Cushion
A7	27191000	MFS-1000,Holder	M4	28141384	0.1*φ24.5*φ18,Cushion
A8	260208	Wire tie	M6	24830004Y	York
A13	27175316B	Leg	M7	24824006Y	Cap
A14	28141332	Cushion	M8	24832006Y	Magnet
A15	831430088	3TTW+8B(BC), Self-tapping screw	M10	24804015Y	RF-500TB-14415,Motor
A17	27300750	△ Bushing, code	M11	24810028Y	Pulley
A19	29361957	Label, Caution	M12	24816010AY	Belt
A22	27300833-2	WS-2NS,Clamp	M15	24810040Y	Gear, pulley
A23	27301779	HL-38-0,Clamp	M16	24810039AY	Gear, load
A24	838430107	3TTB+10S(BC), Self-tapping screw	M17	24810041Y	Cam gear A
A51	27122577	Rear panel <D>	M18	24810042Y	Cam gear B
	27122578	Rear panel <P/A>	M20	831430088	3TTW+8B(BC), Self-tapping screw
	27122579	Rear panel <W>	M23	24802024Y	Chassis, sub
	27122580	Rear panel <T>	M24	24840111	Screw
A301	28184680A	Top cover 	M25	24800017Y	KSM-213CCM, Mechanical unit
	28184681A	Top cover <S>	M26	24818013Y	Insulator A
A302	838430088	3TTB+8B(BC),Self-tapping screw 	M27	24818014Y	Insulator B
	838930088	3TTB+8B(UN),Self-tapping screw <S>	M28	204416004Y	NCFC4-16004, Flexible flat cable
A501	27212092	Front panel 	M29	2009990464	NASA-12P618,Socket
	27212093	Front panel <S>	M30	24840111	Screw
A502	28135244Y	Badge 	M33	24840107B	Tray
	28135245Y	Badge <S>	M34	24804021Y	RF-310TA-11400, Motor
A503	838130088	3TTB+8B(BC),Self-tapping screw	M35	24810047	Pulley B
A506	28148365	Door 	M36	24822018Y	Retainer
	28148366	Door <S>	M37	838130088	3TTB+8B, Self-tapping screw
E1	204329005Y	NCFC3-29005, Flexible flat cable	M40	24810045Y	Worm ass'y
E2	204307007	NCFC3-07007,Flexible flat cable	M43	24810043Y	Gear, wheel
P951	253279HIT	△ AS-UC-2#18, Power supply cord <D>	M44	831430088	3TTW+8B(BC), Self-tapping screw
	253193HIT	△ AS-CEE, Power supply cord <P/T/W>	M45	24834017Y	Spacer
	253197HIT	△ AS-SAA,Power supply cord <A>	M46	24840111	Screw
T901	2300992Y	△ NPT-1200D,Power transformer <D>	M47	24816104	Belt
	2300993Y	△ NPT-1200P,Power transformer <P/T/A>	M48	24840110Y	Roller
	2300994Y	△ NPT-1200DG,Power transformer <W>	M49	28141340	Cushion
U1	1H401580-3A	NAAR-5880-3A,Main circuit PC board ass'y <D/P/T/A>	M50	24840108Y	Roulette
	1H401580-3B	NAAR-5880-3B,Main circuit PC board ass'y <W>	M51	24834016Y	Washer A
U2	1H401581-3A	NADIS-5881-3A, Display circuit PC board ass'y <D/P/T/A>	M52	24820033Y	Spring A
	1H401581-3B	NADIS-5881-3B, Display circuit PC board ass'y <W>	M53	24840111	Screw
U3	1H401582-3A	NAPS-5882-3A,Power supply circuit PC board ass'y <D/P/T/A>	M59	838426088	2.6TTB+8B(BC), Self-tapping screw
	1H401582-3B	NAPS-5882-3B,Power supply circuit PC board ass'y <W>			
U4	1H401583-3A	NASW-5883-3A,Power switch PC board ass'y <D/P/T/A>			
	1H401583-3B	NASW-5883-3B,Power switch PC board ass'y <W>			

NOTE: : Black model only
 <S>: Silver model only
 <D>: 120V model only
 <P>: European model only
 <T>: Asian model only
 <W>: Worldwide model only

NOTE: THE COMPONENTS IDENTIFIED BY MARK △
 ARE CRITICAL FOR RISK OF FIRE AND
 ELECTRIC SHOCK. REPLACE ONLY WITH
 PART NUMBER SPECIFIED.

PICK-UP DRIVE UNIT

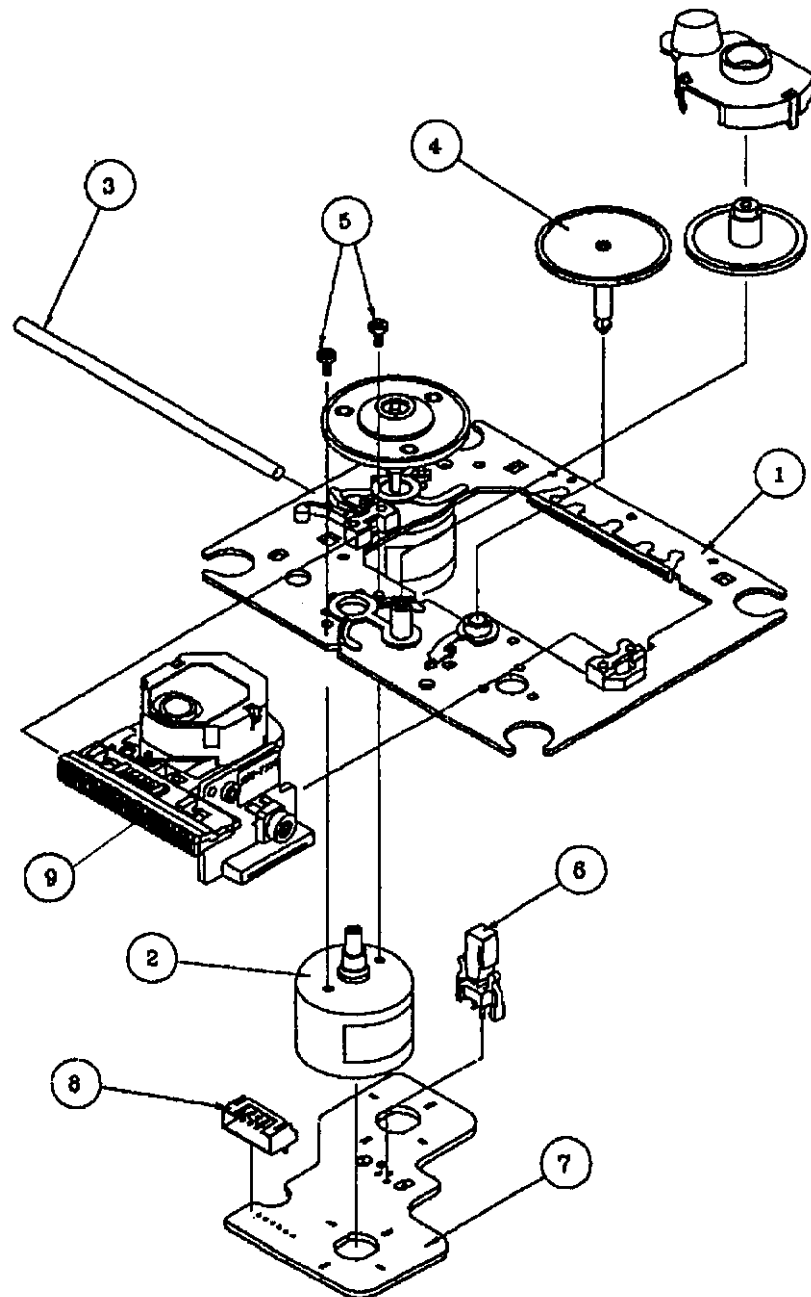

REF.NO.	PART NO.	DESCRIPTION
1	X-2625-877-1	Motor chassis ass'y
2	X2625-769-1	Motor gear ass'y
3	2626-908-01	Sled shaft
4	24810023	Gear A
5	7621-255-15	P2x3,Pan head screw
6	24840008	Leaf switch
7	1639-678-12	Motor PC board
8	1564-722-11	6P, Connector pin
9	8848-483-05	KSS-213C, Optical pickup

PRINTED CIRCUIT BOARD-PARTS LIST

MAIN CIRCUIT PC BOARD(NAAR-5830-3A/3B)

CIRCUIT NO.	PART NO.	DESCRIPTION	CIRCUIT NO.	PART NO.	DESCRIPTION
					Capacitors
			C123	354780339	3.3 μ F,50V,Elect.
			C125,C127	354744709	47 μ F,16V,Elect.
			C128,C135	354744709	47 μ F,16V,Elect.
			C129,C138	374721034	0.01 μ F \pm 5%,50V,Plastic
			C131	374722224	2200pF \pm 5%,50V,Plastic
			C202,C211	354721019	100 μ F,6.3V,Elect.
			C205,C303	354784799	0.47 μ F,50V,Elect.
			C206	354782299	0.22 μ F,50V,Elect.
			C207	354721029	1000 μ F,6.3V,Elect.
			C215,C216	354781019	100 μ F,50V,Elect.
			C301	374722234	0.022 μ F \pm 5%,50V,Plastic
			C302	374721524	1500pF \pm 5%,50V,Plastic
			C304,C306	374721034	0.01 μ F \pm 5%,50V,Plastic
			C308	354721019	100 μ F,6.3V,Elect.
			C311-C313	354722219	220 μ F,6.3V,Elect.
			C314	354724719	470 μ F,6.3V,Elect.
			C316,C317	354741009	10 μ F,16V,Elect.
			C401,C402	374723924	3900pF \pm 5%,50V,Plastic
			C403-C406	374721824	1800pF \pm 5%,50V,Plastic
			C407,C408	374724714	470pF \pm 5%,50V,Plastic
			C409,C410	374721824	1800pF \pm 5%,50V,Plastic
			C411,C412	374723924	3900pF \pm 5%,50V,Plastic
			C413,C414	374722724	2700pF \pm 5%,50V,Plastic
			C415,C416	354781009	10 μ F,50V,Elect.
			C417-C420	374722734	0.027 μ F \pm 5%,50V,Plastic
			C421,C422	354744709	47 μ F,16V,Elect.
			C423	374722734	0.027 μ F \pm 5%,50V,Plastic
			C910-C912	354744709	47 μ F,16V,Elect.
			C913	354721029	1000 μ F,6.3V,Elect.
			C916,C917	354764709	47 μ F,35V,Elect.
					Resistors
			R108,R126	5210263	N06HR20KBC
					Terminals
			P201	25045481 or	NPJ-2PDBL299 or
				25045330	NPJ-2PDBL184
			P401	25045353	NPJ-2PDBL199
					Plugs
			P102A,P104A	25055150	NPLG-6P134
			P103A	25055149	NPLG-5P133
			P106	25055038	NPLG-2P29
			P107	25055045	NPLG-4P33
					Sockets
			P101	25051768	NSCT-16P1555
			P105A	25051851	NSCT-7P1638
			P202A	25051836	NSCT-29P1623
			P901A	25050273	NSCT-9P101
			P902A	25050269	NSCT-5P97
					Radiators
			Q901A,Q902A	27160145-1	RAD-51

CIRCUIT NO.	PART NO.	DESCRIPTION
Screws		
Q901B,Q902B	838430107	3TTB+10S(BC)
Holders		
X301A	27190751	
E701	27190941	(FL)

DISPLAY CIRCUIT PC BOARD (NADIS-5881-3A/3B)

CIRCUIT NO.	PART NO.	DESCRIPTION
Q701	212132	5-ST-19GK,FL tube
Q702	24130011	PIC-12043TE2,Remote sensor
C701	353721019	100 μ F,6.3V,Elect. Capacitor
P702B	25051873	NSCT-29P1660,Socket
S701-S719	25035652	NPS-111-S604,Switch

POWER SUPPLY CIRCUIT PC BOARD (NAPS-5882-3A/3B)

CIRCUIT NO.	PART NO.	DESCRIPTION
Diodes		
D901-D907	22380260 or 22380035	RL1N4003 or GP104003E
Coil		
L901	231222	Δ NCH-3454
Capacitors		
C901	354744729S	4700 μ F,16V,Elect.
C902	393342227	2200 μ F,16V,Elect.
C905	354784709	47 μ F,50V,Elect.
C906	354780229	2.2 μ F,50V,Elect.
C908,C909	354744719	470 μ F,16V,Elect.
Sockets		
P901B	25051113	NSCT-9P900
P902B	25051109	NSCT-5P896
Plug		
P903	25055676	NPLG-2P632
Switch		
S902	25065437	Δ NSS-22157P <W>

POWER SWITCH PC BOARD (NASW-5883-3A/3B)

CIRCUIT NO.	PART NO.	DESCRIPTION
C950	3500191	Δ DE7150F-103M,IS capacitor
S901	25035636	Δ NPS-111-L590P,Power switch

MECHANISM SECTION PC BOARD-PARTS LIST

CIRCUIT NO.	PART NO.	DESCRIPTION
Q001	24190041	SG-207,Photo interrupter
Q002	24190046	GP2S28,Photo interrupter
Q003	24190041	SG-207,Photo interrupter
C001	354744709	47 μ F,16V,Elect. Capacitor
C002	352942206	22 μ F,16V,Elect. Capacitor
C003	354744709	47 μ F,16V,Elect. Capacitor
C004	352942206	22 μ F,16V,Elect. Capacitor
S001	25065491	NMS-1223,Micro switch
S002	25065375	NMS-1219,Micro switch
P001A	2002390605UL	NSAS-6P0597,Socket
P001B	25055367	NPLG-3P350,Plug
P103	2009990447UL	NSAS-10P0596,Socket
P104	2009990446UL	NSAS-11P0595,Socket
P105B	25051851Y or 25050913	NSCT-7P1638 or NSCT-7P700,Socket

NOTE: <W>: Worldwide model only

NOTE: THE COMPONENTS IDENTIFIED BY MARK Δ ARE CRITICAL FOR RISK OF FIRE AND ELECTRIC SHOCK. REPLACE ONLY WITH PART NUMBER SPECIFIED.

SCHEMATIC DIAGRAM

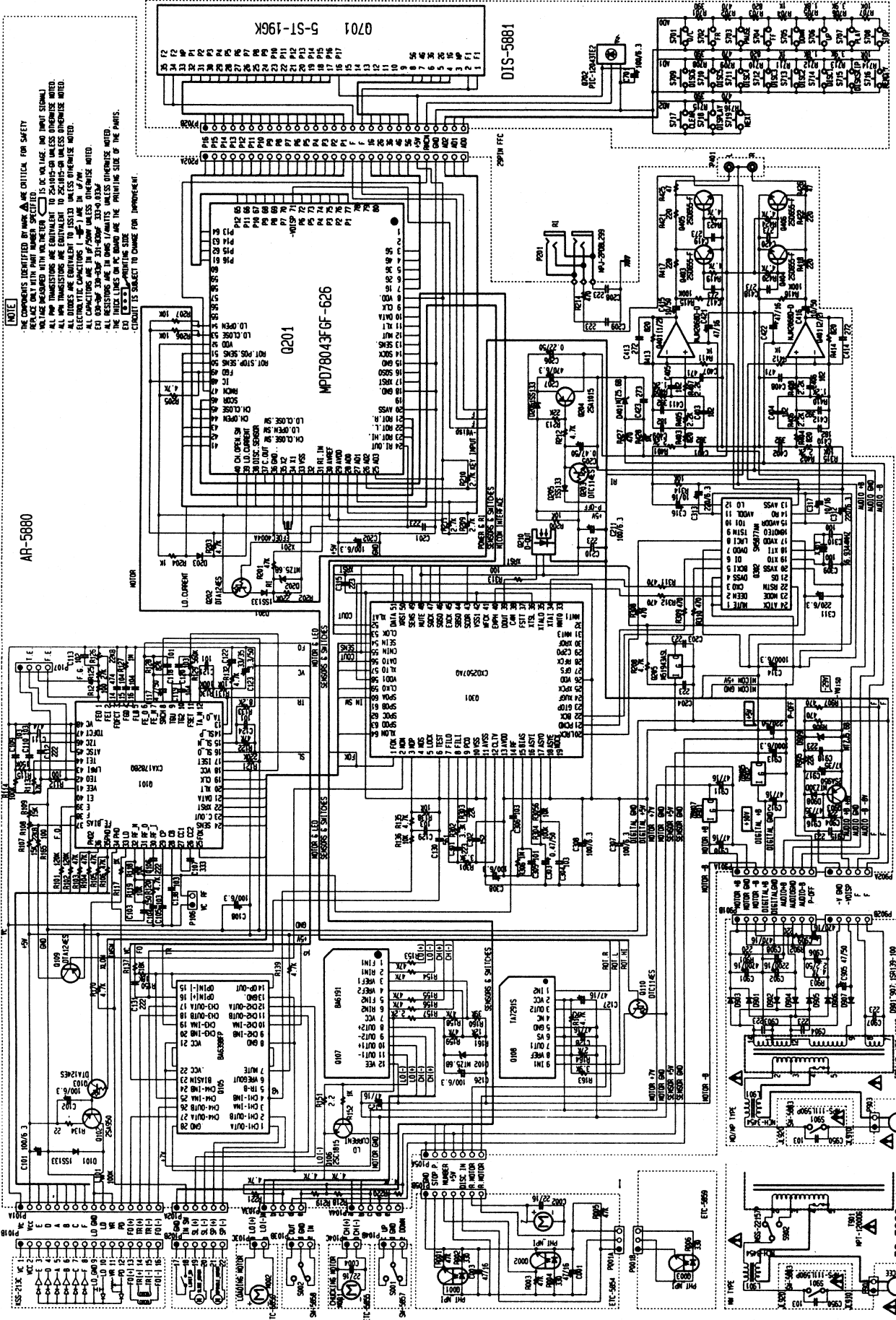

NOTE

THE COMPONENTS IDENTIFIED BY MARK 'A' ARE CRITICAL FOR SAFETY. REPAIR OR REPLACEMENT MUST BE MADE IN ACCORDANCE WITH THE ORIGINAL MANUFACTURER'S SPECIFICATIONS. ALL WIP TRANSISTORS ARE EQUIVALENT TO 2SA105-OR UNLESS OTHERWISE NOTED. ALL DIODES ARE EQUIVALENT TO 1N4148-OR UNLESS OTHERWISE NOTED. ALL CAPACITORS ARE EQUIVALENT TO 50V UNLESS OTHERWISE NOTED. ALL RESISTORS ARE 1/4 WATT UNLESS OTHERWISE NOTED. THE INDEX LINES ON PC BOARD ARE THE PRINTING SIDE OF THE PARTS. CHECK FOR CORRECT POLARITY TO AVOID DAMAGE TO COMPONENTS.

ADJUSTMENT PROCEDURES

Instruments required

Dual trace oscilloscope, Frequency counter, AF oscillator, Test disc (SONY YEDS-18) and AC voltmeter.

1. Focus offset adjustment

Turn R108 and R126 to the mechanical center.

Load the test disc YEDS-18 on the tray and play the track 2.

Connect the oscilloscope to terminal P106.

Adjust R108 until the waveform on the oscilloscope becomes maximum.

After adjustment, disconnect the oscilloscope.

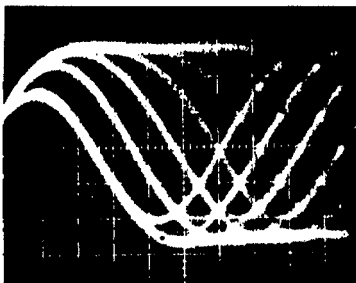
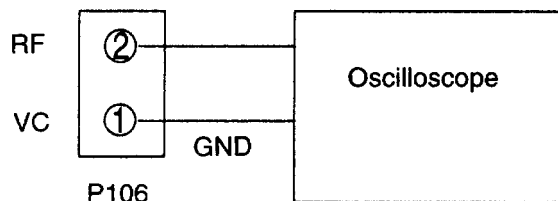

Photo 1

0.2V/div
0.2 μ s/div



2. Focus gain adjustment

Set the output of AF oscillator to 1kHz, 2 Vp-p.

Play the track 2 of test disc.

Connect the oscilloscope and the AF oscillator as shown below.

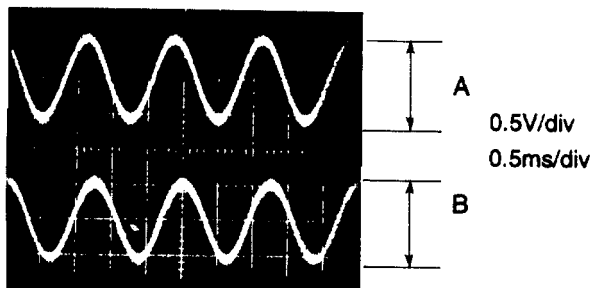
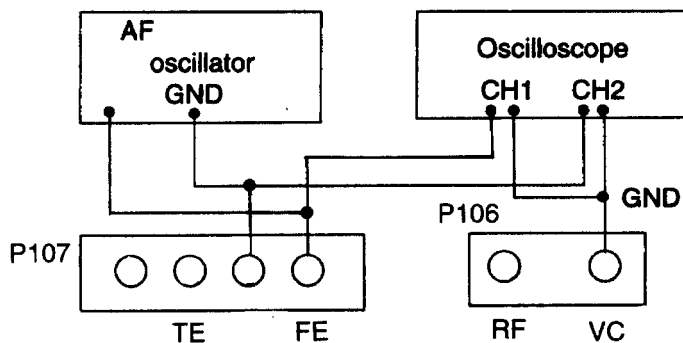

Photo 2

A
0.5V/div
0.5ms/div

B



Adjust R126 until 1kHz components of channels 1 and 2 on oscilloscope become same level.

After adjustment, disconnect the AF oscillator and the oscilloscope.