

# ONKYO SERVICE MANUAL

## COMPACT DISC CHANGER MODEL DX-C390

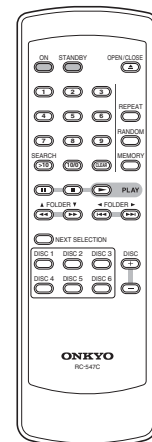
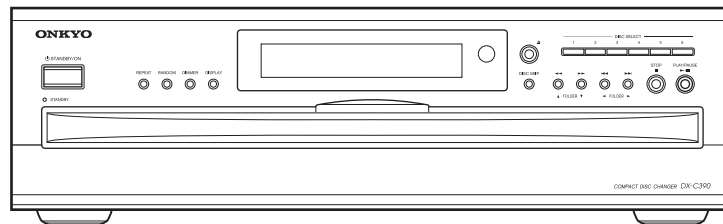

RC-547C

### Black and Silver models

BMDD	120V AC, 60Hz
BMPP, SMPP	230V AC, 50Hz
BMPA	230-240V AC, 50Hz

### SAFETY-RELATED COMPONENT WARNING!!

COMPONENTS IDENTIFIED BY MARK  ON THE SCHEMATIC DIAGRAM AND IN THE PARTS LIST ARE CRITICAL FOR RISK OF FIRE AND ELECTRIC SHOCK. REPLACE THESE COMPONENTS WITH ONKYO PARTS WHOSE PART NUMBERS APPEAR AS SHOWN IN THIS MANUAL.

MAKE LEAKAGE-CURRENT OR RESISTANCE MEASUREMENTS TO DETERMINE THAT EXPOSED PARTS ARE ACCEPTABLY INSULATED FROM THE SUPPLY CIRCUIT BEFORE RETURNING THE APPLIANCE TO THE CUSTOMER.

# ONKYO®

IMAGINATIVE SIGHT &amp; SOUND

## SPECIFICATIONS

### DX-C390 (Compact Disc Changer)

Signal readout system	Optical non-contact
Frequency response	5 Hz - 20 kHz
SN ratio	98 dB
Audio Dynamic range	96 dB
THD (Total harmonic distortion)	0.005% (at 1 kHz)
Audio output (Digital/Optical)	-22.5 dBm
Audio output/Impedance (Digital/Coaxial)	0.5 V (p-p) / 75 ohm
Audio output/Impedance (Analog)	2.0 V (rms) / 470 ohm
Power supply rating	AC 120 V    60 Hz (North American model) AC 230 V    50 Hz (Other than North American models)
Power consumption	10 W (North American model) 8 W (Other than North American models)
Standby power consumption	4 W
Dimensions (W x H x D)	17-1/8" x 5-3/16" x 17" (435 x 131 x 432 mm)
Weight	15.0 lbs. (6.8 kg)
Operating conditions Temperature/Humidity	41-95 °F (5-35 °C) / 25-80%
Disc compatibility	CD, CD-R, CD-RW

### RC-547C (Remote Controller)

Transmitter	Infrared
Signal range	Approx. 16 ft., 5 meters
Power supply	Two (AA/R6) batteries (1.5 V x 2)

Specifications and features are subject to change without notice.

## SERVICE PROCEDURES

### PROTECTION OF EYES FROM LASER BEAM DURING SERVICING

This set employs a laser. Therefore, be sure to follow carefully the instructions below when servicing.

#### WARNING!!

**SERVICE WARNING : DO NOT APPROACH THE LASER EXIT WITH THE EYE TOO CLOSELY. IN CASE IT IS NECESSARY TO CONFIRM LASER BEAM EMISSION, BE SURE TO OBSERVE FROM A DISTANCE OF MORE THAN 30cm FROM THE SURFACE OF THE OBJECTIVE LENS ON THE OPTICAL PICKUP BLOCK.**

#### LASER WARNING LABEL

The labels shown below are affixed.

##### Warning label

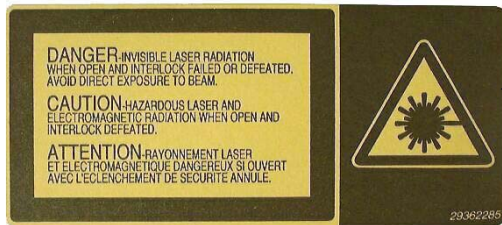

##### DANGER:

INVISIBLE LASER RADIATION WHEN OPEN AND INTERLOCK FAILED OR DEFEATED. AVOID DIRECT EXPOSURE TO BEAM.

##### CAUTION:

HAZARDOUS LASER AND ELECTROMAGNETIC RADIATION WHEN OPEN AND INTERLOCK DEFEATED.

##### ATTENTION:

RAYONNEMENT LASER ET ELECTROMAGNETIQUE DANGEREUX SI OUVERT AVEC L'ECLANCHEMENT DE SECURITE ANNULE.

---

#### Safety check out (Only U.S.A. model)

After correcting the original service problem perform the following safety check before releasing the set to the customer.

Connect the insulating-resistance tester between the plug of power supply cord and terminal GND on the back panel.

Specifications: More than 10 M ohm at 500V.

---

#### Initializing the unit

Press "STOP" key and "STANDBY" key at same time. Displayed "INITIALIZE" on the FL display.

## PANEL VIEW-1

### FRONT PANEL

#### North American Model

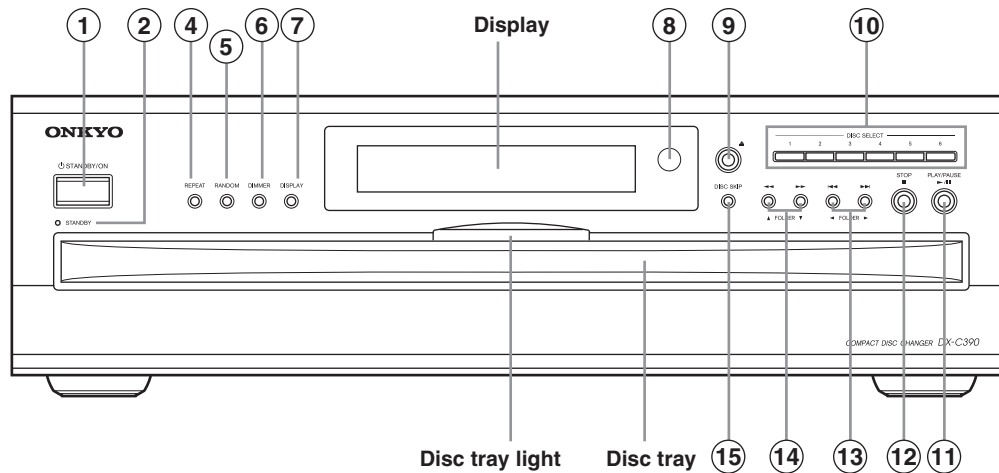

#### Other Models

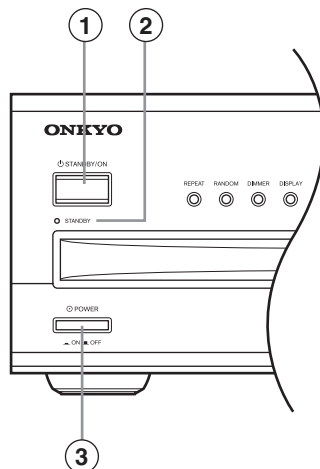

For detailed information, refer to the pages in parenthesis.

#### ① STANDBY/ON button

This button is used to set the DX-C390 to On or Standby. For models with a POWER switch, this button has no effect unless that POWER switch is set to ON.

#### ② STANDBY indicator

This indicator lights up when the DX-C390 is in Standby mode.

#### ③ POWER switch (not North American model)

This is the main power switch. When set to OFF, the DX-C390 is completely shutdown.

#### ④ REPEAT button

This button is used with the Repeat function.

#### ⑤ RANDOM button

This button is used with the Random function.

#### ⑥ DIMMER button

This button is used to adjust the display brightness.

#### ⑦ DISPLAY button

This button is used to display elapsed, remaining, and total time information about the current disc or track and various information about MP3 tracks.

#### ⑧ Remote control sensor

This sensor receives control signals from the remote controller.

#### ⑨ [▲] button

This button is used to open and close the disc tray.

#### ⑩ DISC SELECT buttons

These buttons are used to select discs. Playback starts automatically when a disc is selected with one of these buttons.

#### ⑪ PLAY/PAUSE [▶]/[⏸] button

This button is used to start and pause playback.

#### ⑫ STOP [■] button

This button is used to stop playback.

#### ⑬ [◀]/[▶] & FOLDER [◀]/[▶] buttons

These buttons are used to select the previous and next tracks and to navigate folders on MP3 discs.

#### ⑭ [◀◀]/[▶▶] & FOLDER [▲]/[▼] buttons

These buttons are used for fast reverse and fast forward and to navigate folders on MP3 discs.

#### ⑮ DISC SKIP button

This button is used to turn the disc tray when loading or removing discs and to select discs for playback.

## PANEL VIEW-2

### DISPLAY

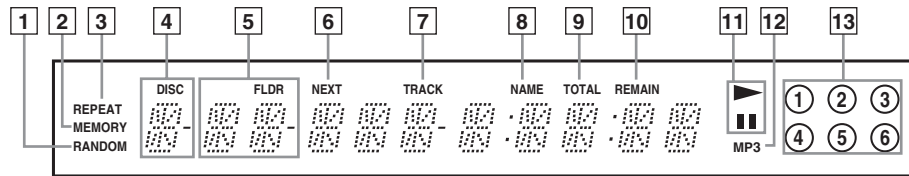

#### 1 RANDOM indicator

#### 2 MEMORY indicator

#### 3 REPEAT indicator

#### 4 DISC indicator

The number of the current disc appears here.

#### 5 FLDR (FOLDER) indicator

While stopped, the total number of folders on the current MP3 disc are displayed. During playback, the number of the current folder is displayed.

#### 6 NEXT indicator

This indicator appears when using the Next Selection function.

#### 7 TRACK indicator

While stopped, the total number of tracks on the current disc are displayed. During playback, the number of the current track is displayed.

#### 8 NAME indicator

This indicator appears when the current disc is an MP3 disc and a name (disc, folder, track) is being displayed.

#### 9 TOTAL indicator

This indicator appears when the total remain time is displayed.

#### 10 REMAIN indicator

#### 11 Play ► / Pause ||| indicator

#### 12 MP3 indicator

#### 13 Disc indicators 1 - 6

### REAR PANEL

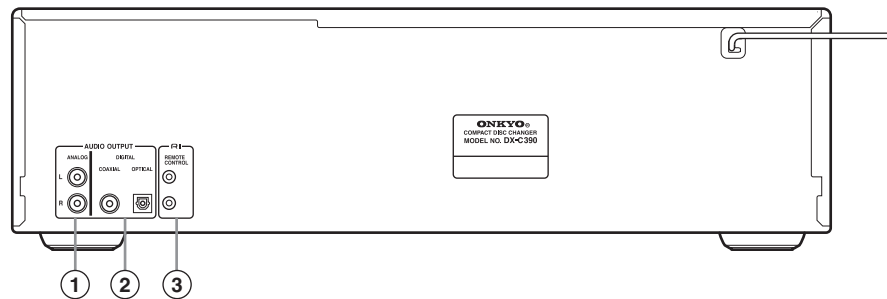

#### 1 ANALOG AUDIO OUTPUT

These RCA/phono connectors can be connected to the analog audio inputs on a hi-P amp or AV receiver.

#### 2 COAXIAL & OPTICAL DIGITAL AUDIO OUTPUT

These connectors can be used to connect a CD-R, MiniDisc, DAT recorder, digital amp, or other equipment with digital inputs.

#### 3 RI REMOTE CONTROL

These **RI** (Remote Interactive) connectors can be connected to the **RI** connectors on your other Onkyo AV components for interactive control.

To use **RI** you must also make analog audio connections (RCA/phono) between the DX-C390 and your other Onkyo equipment.

## PANEL VIEW-3

## REMOTE CONTROLLER

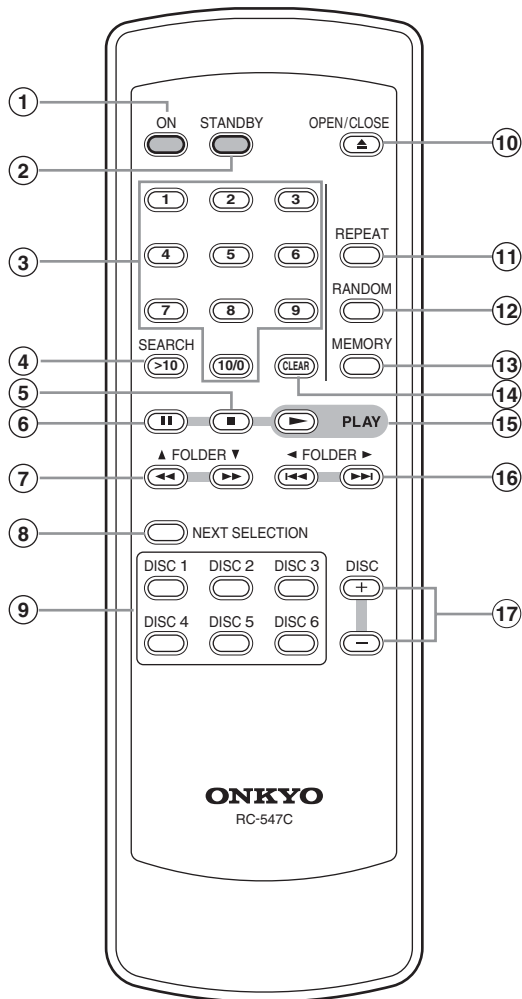

- ① **ON button**  
This button is used to turn on the DX-C390.
- ② **STANDBY button**  
This button is used to set the DX-C390 to Standby.
- ③ **Number buttons**  
These buttons are used to enter track and MP3 folder numbers.
- ④ **SEARCH (>10) button**  
This button is used to enter track numbers above 10 and to select MP3 folders.
- ⑤ **[■] button**  
This button is used to stop playback.
- ⑥ **[|||] button**  
This button is used to pause playback.
- ⑦ **[<<]/[>>] & FOLDER [▲]/[▼] buttons**  
These buttons are used for fast reverse and fast forward, and to navigate folders on MP3 discs.
- ⑧ **NEXT SELECTION button**  
This button is used with the Next Selection function for cueing up the next track.
- ⑨ **DISC SELECT buttons**  
These buttons are used to select discs. Playback starts automatically when a disc is selected with one of these buttons.
- ⑩ **OPEN/CLOSE [▲] button**  
This button is used to open and close the disc tray.
- ⑪ **REPEAT button**  
This button is used with the Repeat function.
- ⑫ **RANDOM button**  
This button is used with the Random function.
- ⑬ **MEMORY button**  
This button is used with the Memory function.
- ⑭ **CLEAR button**  
This button is used to cancel various functions.
- ⑮ **PLAY [▶] button**  
This button is used to start playback.
- ⑯ **[<<<]/[>>>] & FOLDER [◀]/[▶] buttons**  
These buttons are used to select the previous and next tracks, and to navigate folders on MP3 discs.
- ⑰ **DISC [+ ] & [-] buttons**  
These buttons are used to select discs.

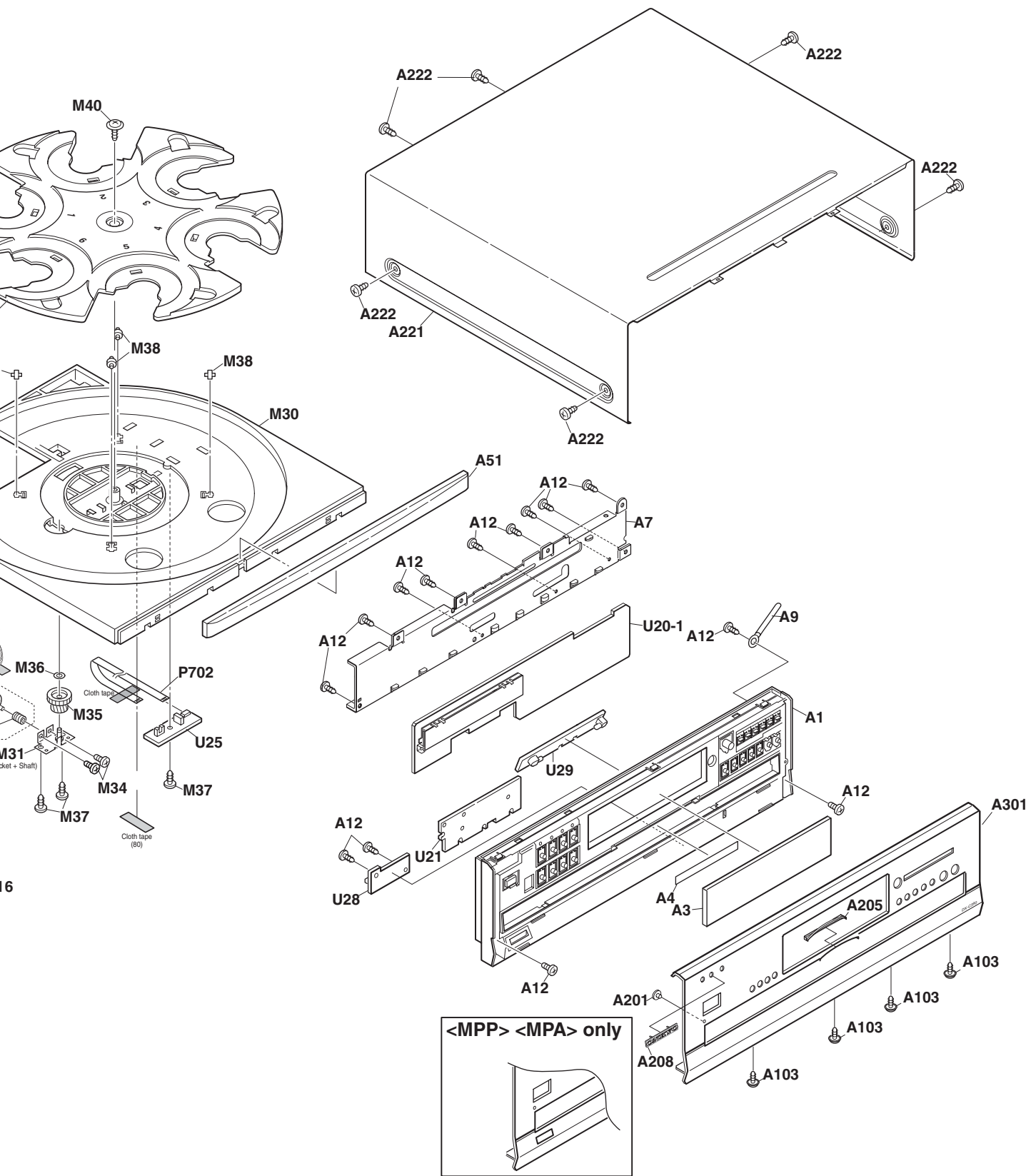







## EXPLODED VIEW OF MECHANISM

### CD DRIVE UNIT : KSM-213CCM

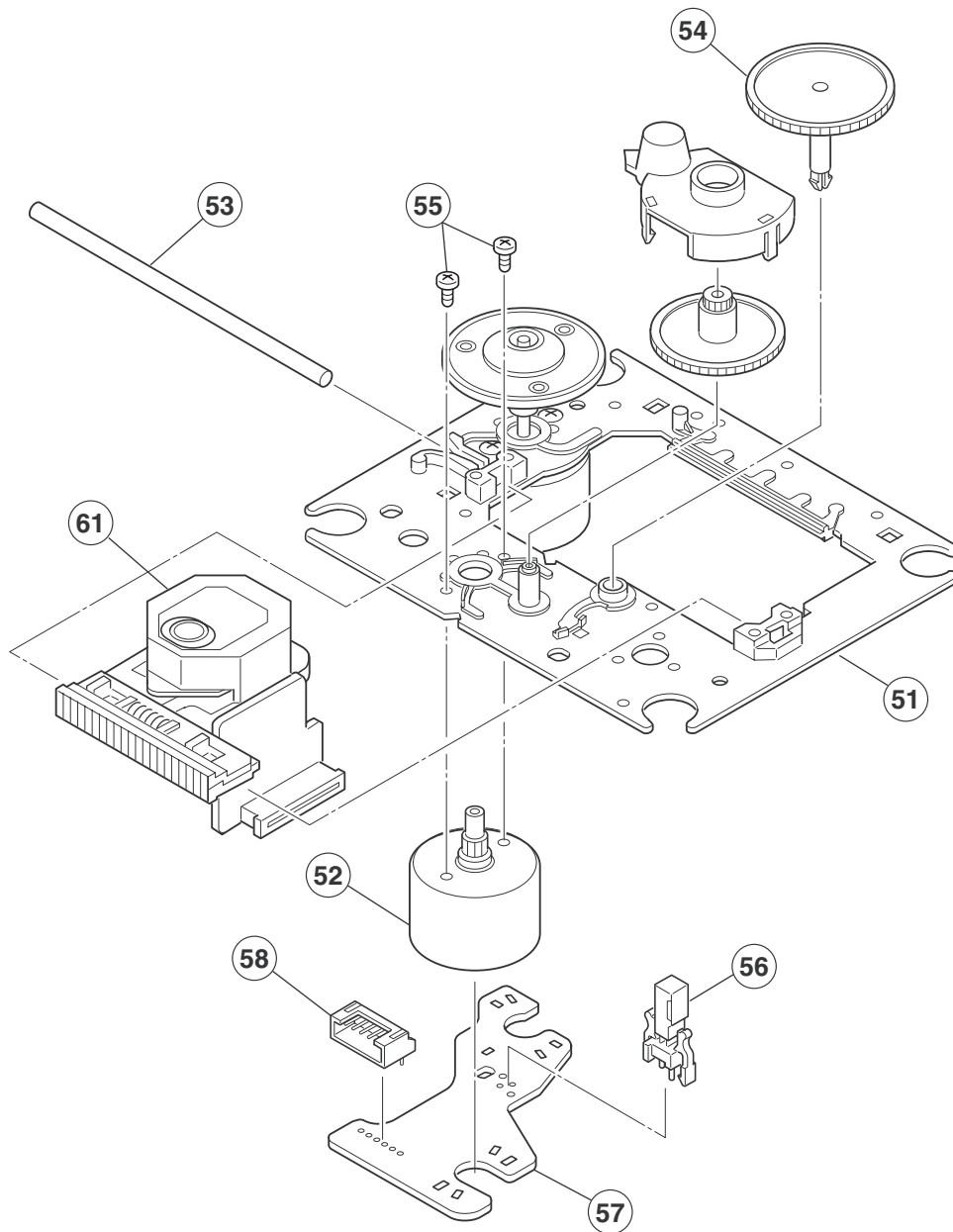

## PARTS LIST

REF. NO.	PART NO.	DESCRIPTION
51	X-2625-877-1	Motor chassis ass'y
52	X2625-769-1	Motor gear ass'y
53	2626-908-01	Sled shaft
54	24810023	Gear (A) (S)
55	7621-255-15	P2 x 3, Screw
56	24840008	Leaf switch
57	1639-678-12	Motor PC board
58	1-564-722-11	Connector 6pin
61	8848-483-05	KSS-213C, Pickup



A B C D E F G H

SCHEMATIC DIAGRAM-2

U20: DISPLAY CIRCUIT PC BOARD NADIS-8054

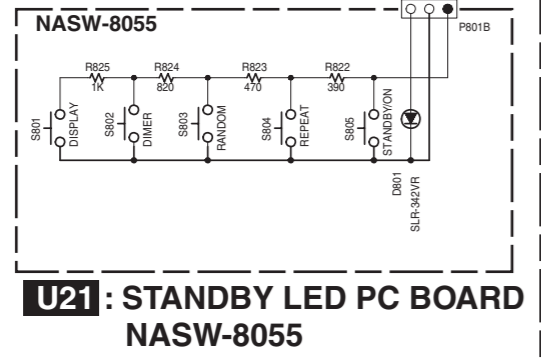
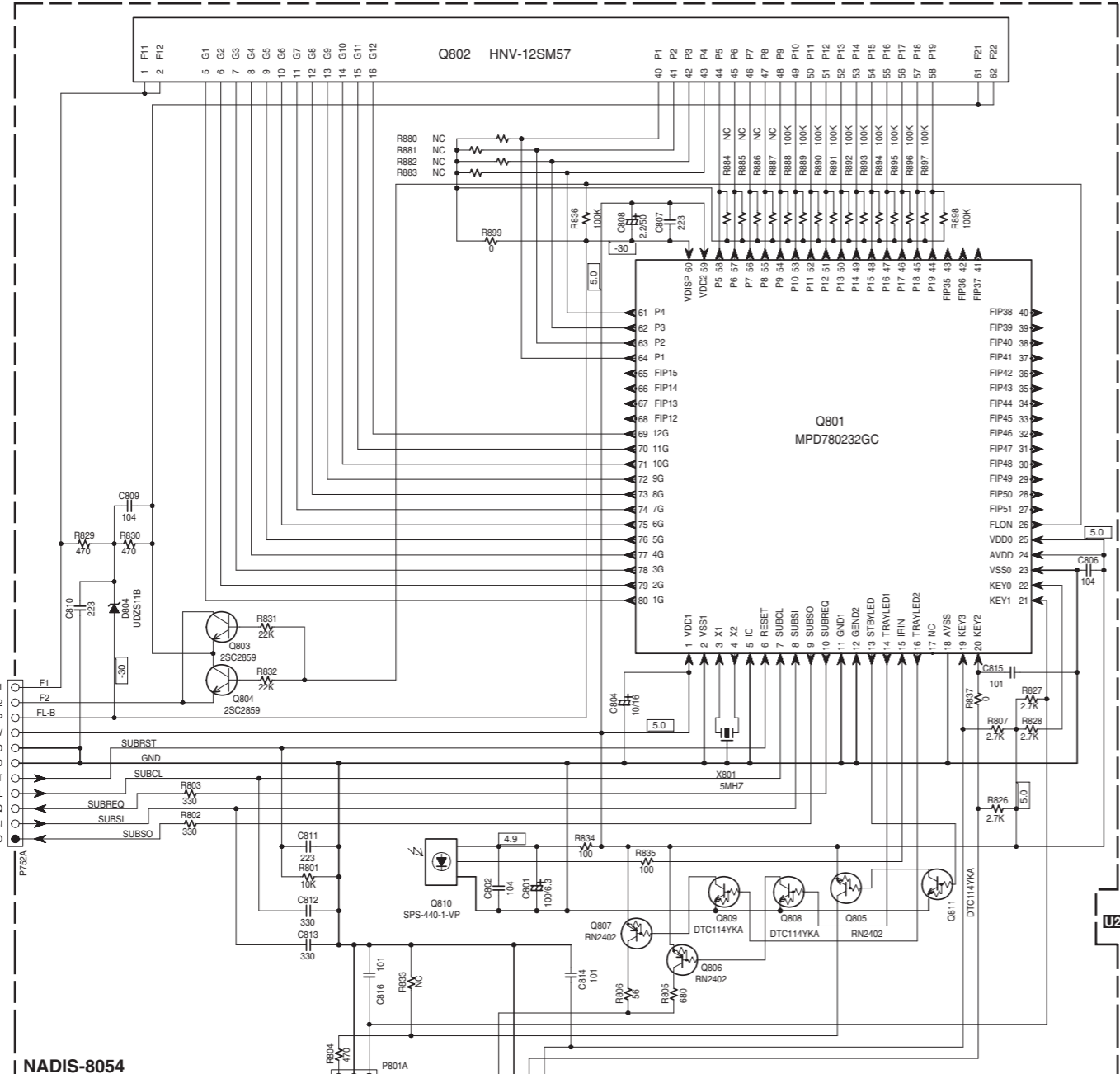

U25: DISC SENSOR PC BOARD NAETC-8059

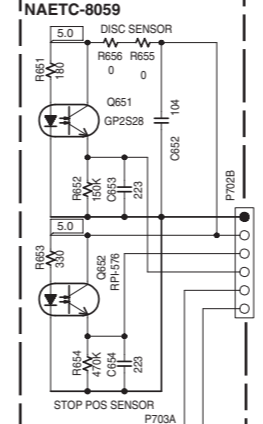

U26: ROULETTE MOTOR PCB NAETC-8060

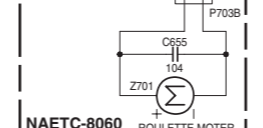

U27: LOADING MOTOR PCB NAETC-8061

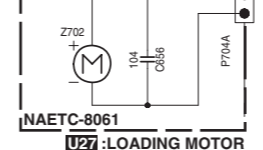

U29: ILLUMINATION PC BOARD NADIS-8066

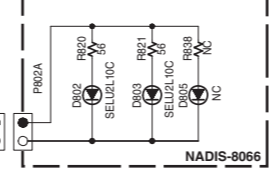

U23: MECHANISM CONTROL PC BOARD NADG-8057

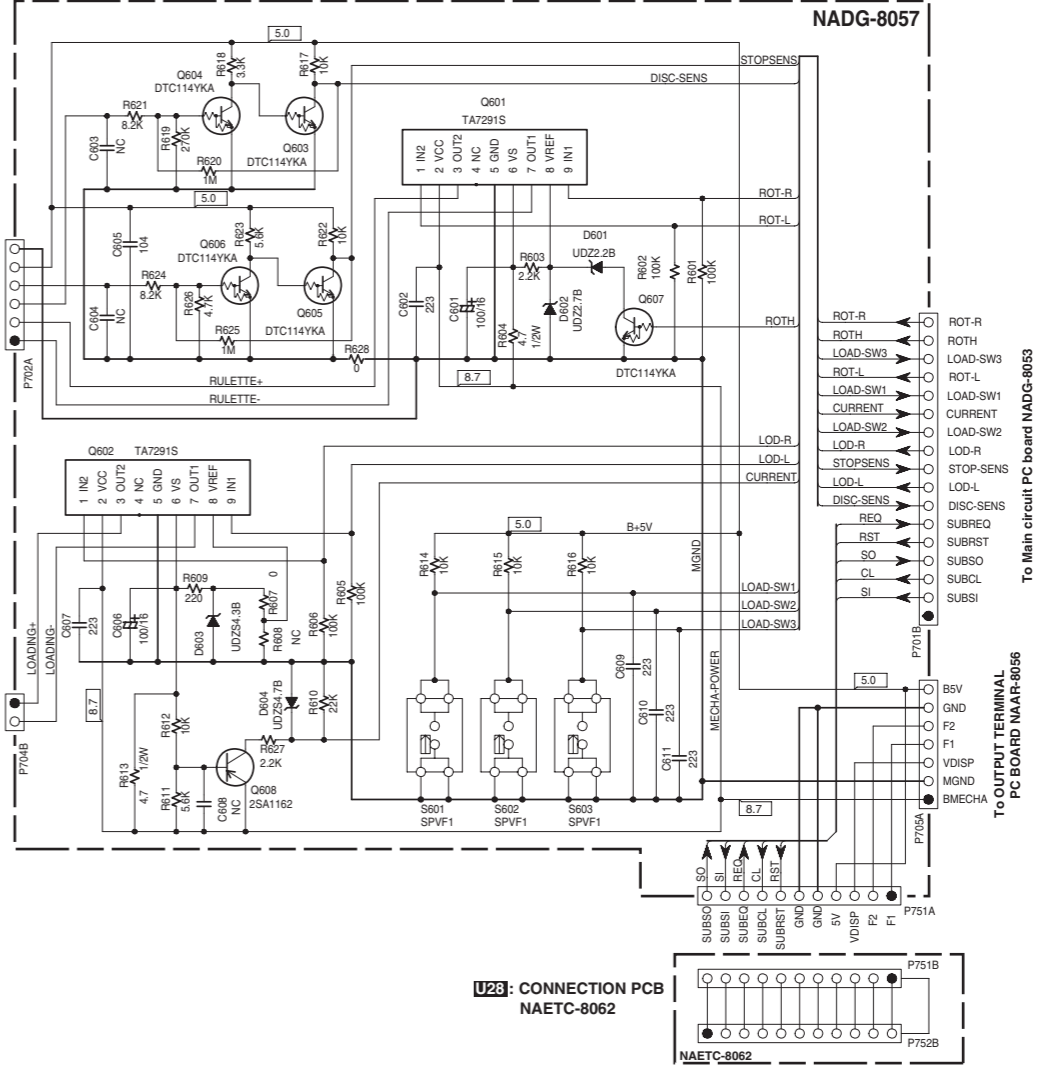

U28: CONNECTION PCB NAETC-8062



1

2

3

4

5





A B C D E F G H

SCHEMATIC DIAGRAM-1

U10: MAIN CIRCUIT PC BOARD NADG-8053

U22: OUTPUT TERMINAL PC BOARD NAAR-8056

1

2

3

4

5

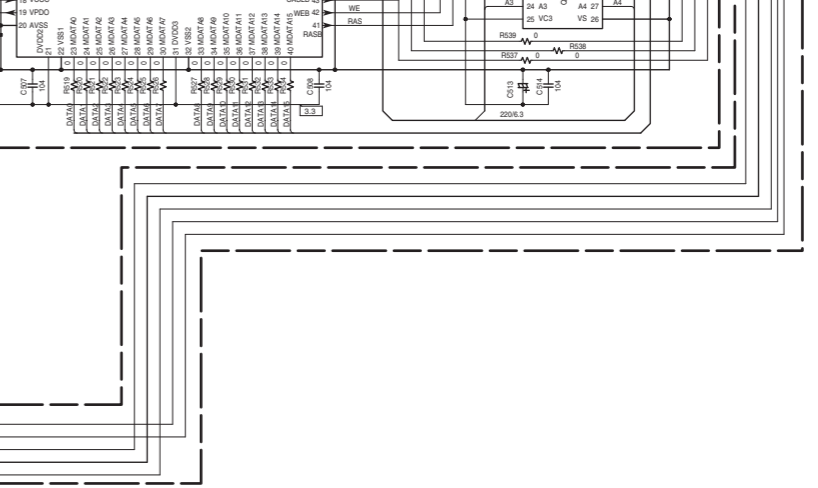
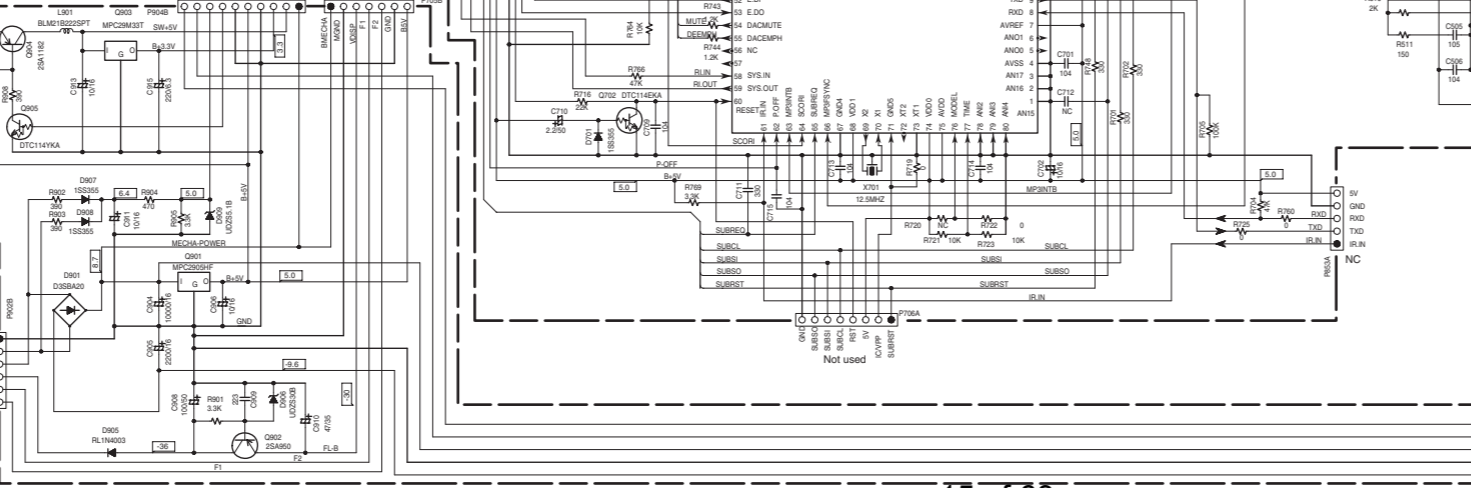
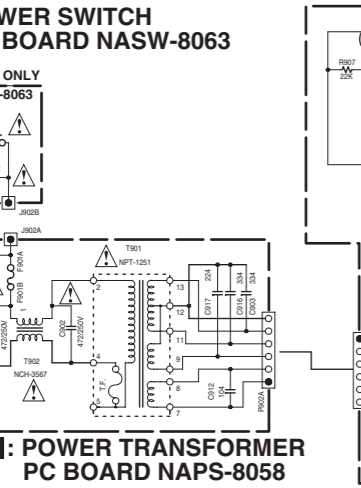
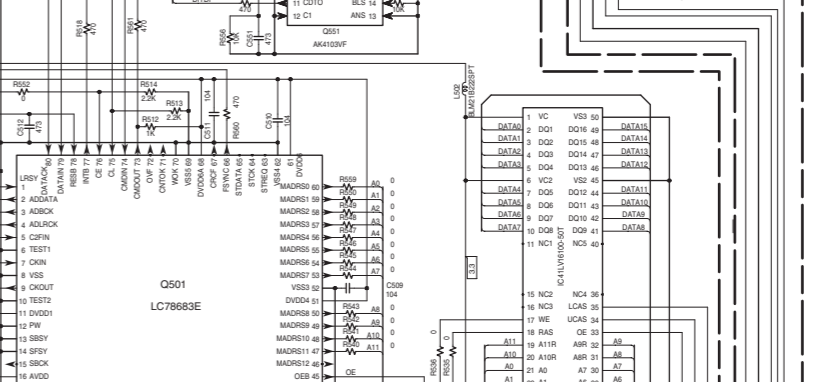
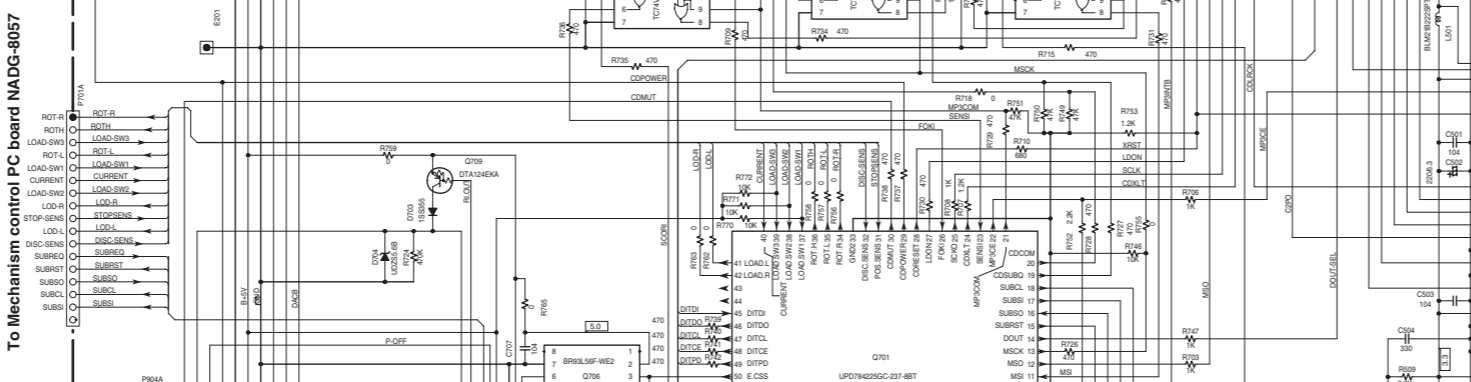
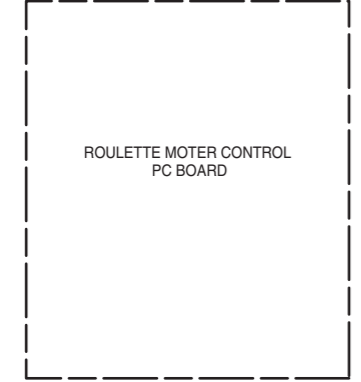
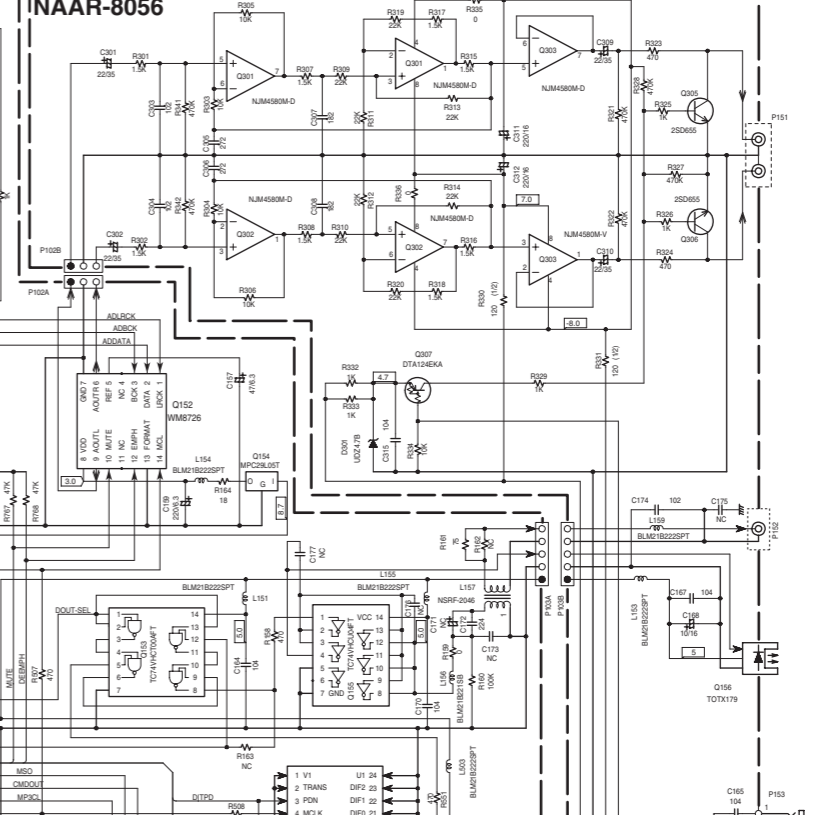
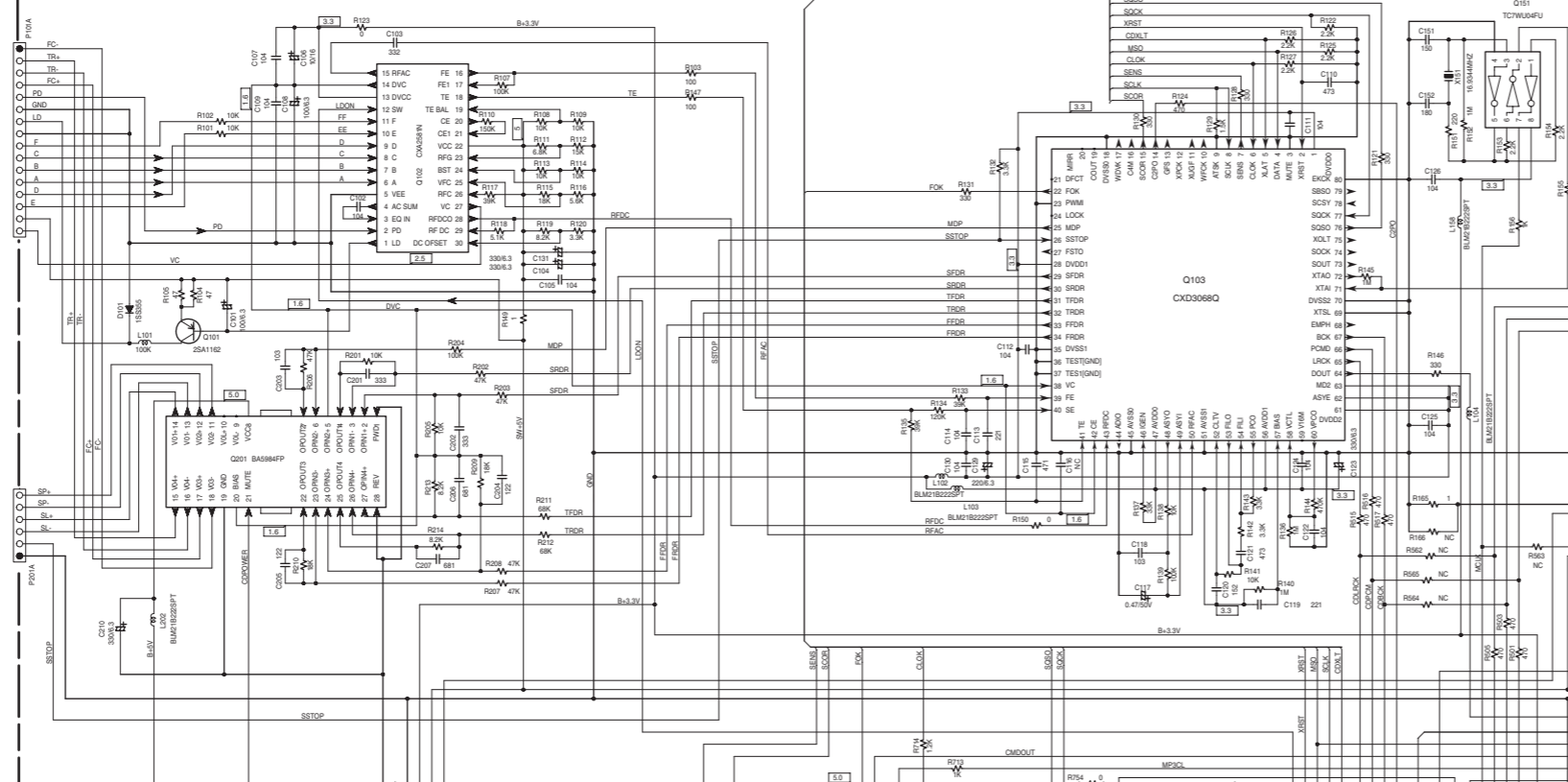
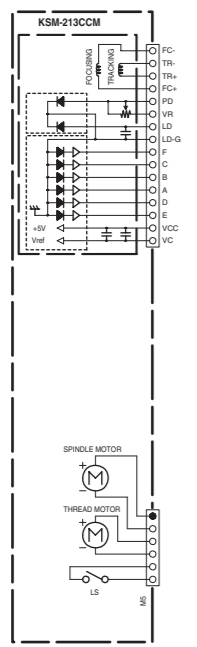

# PC BOARD CONNECTION DIAGRAM

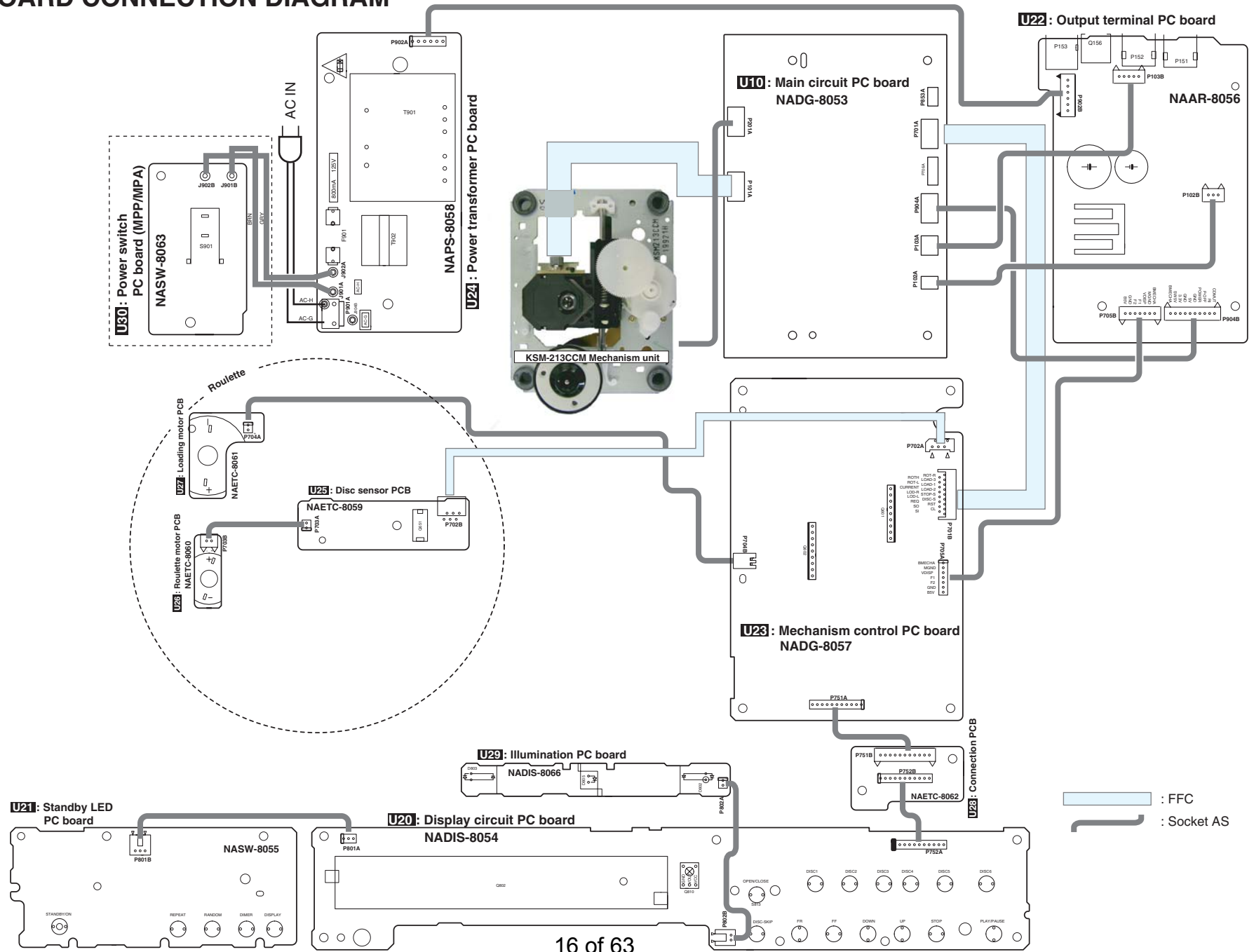



# PRINTED CIRCUIT BOARD VIEW-1

## U10: MAIN CIRCUIT PC BOARD NADG-8053

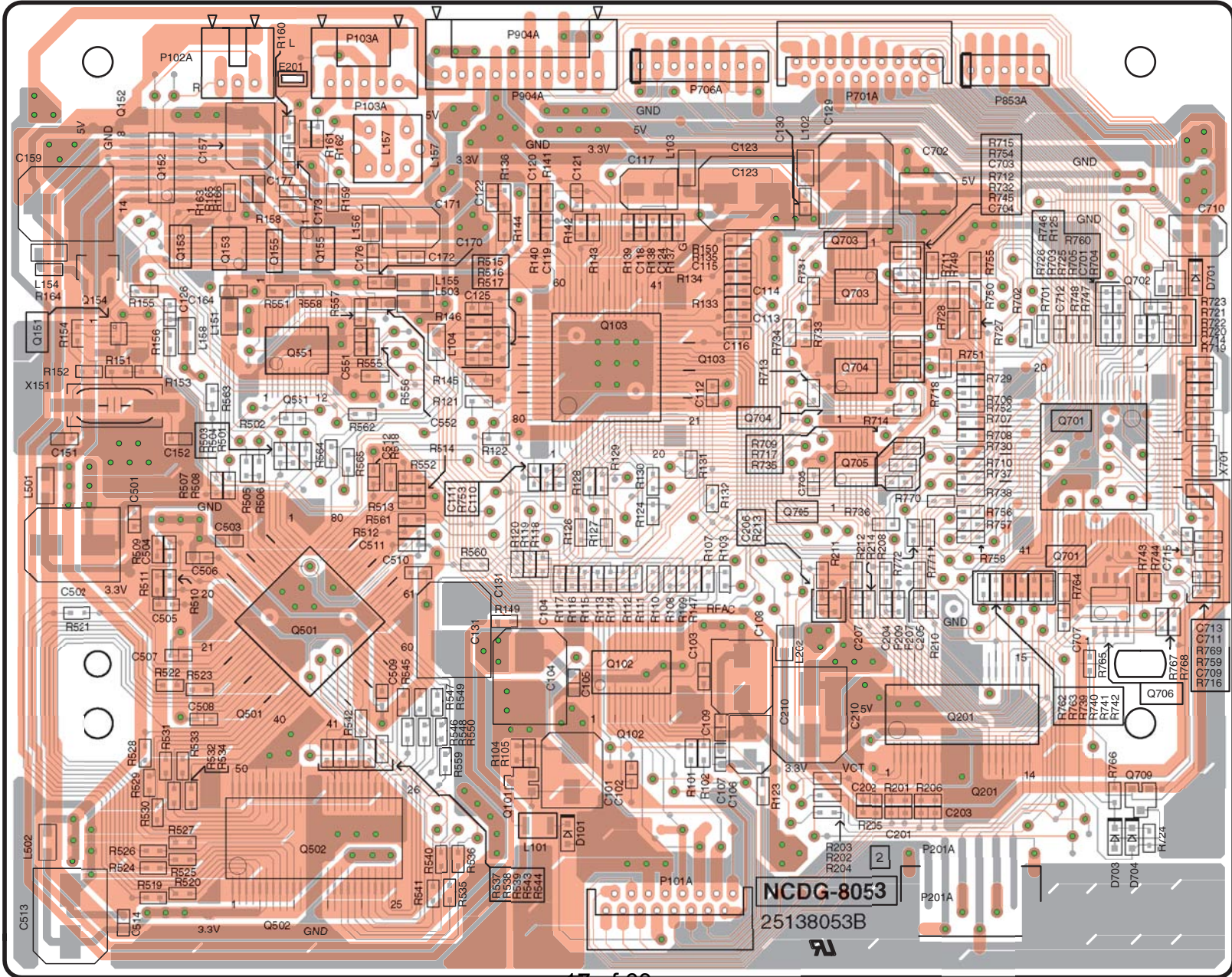

# PRINTED CIRCUIT BOARD VIEW FROM SOLDERING SIDE-2

## U20: DISPLAY CIRCUIT PC BOARD NADIS-8054

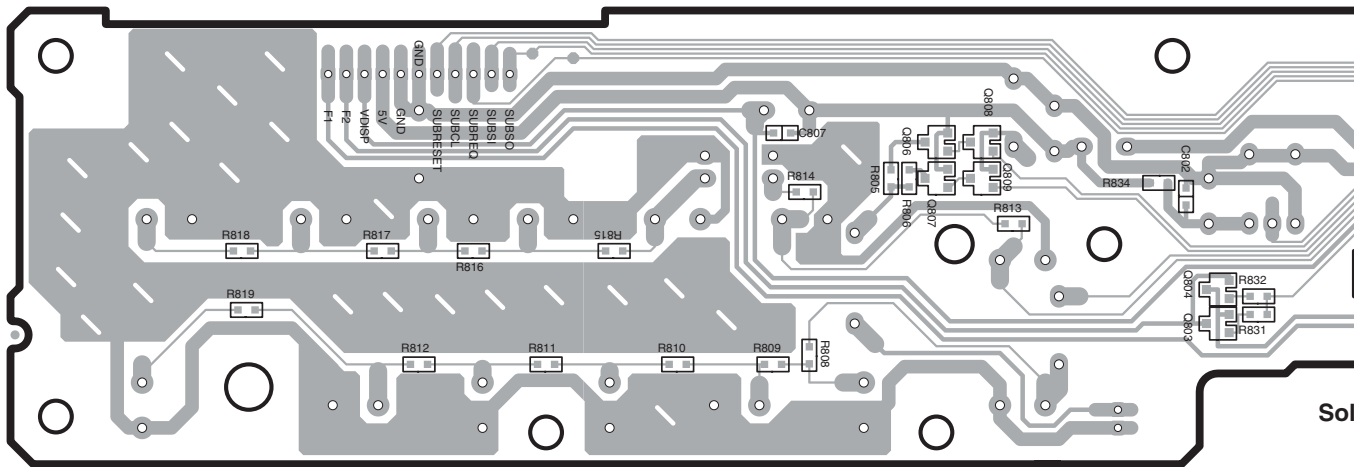
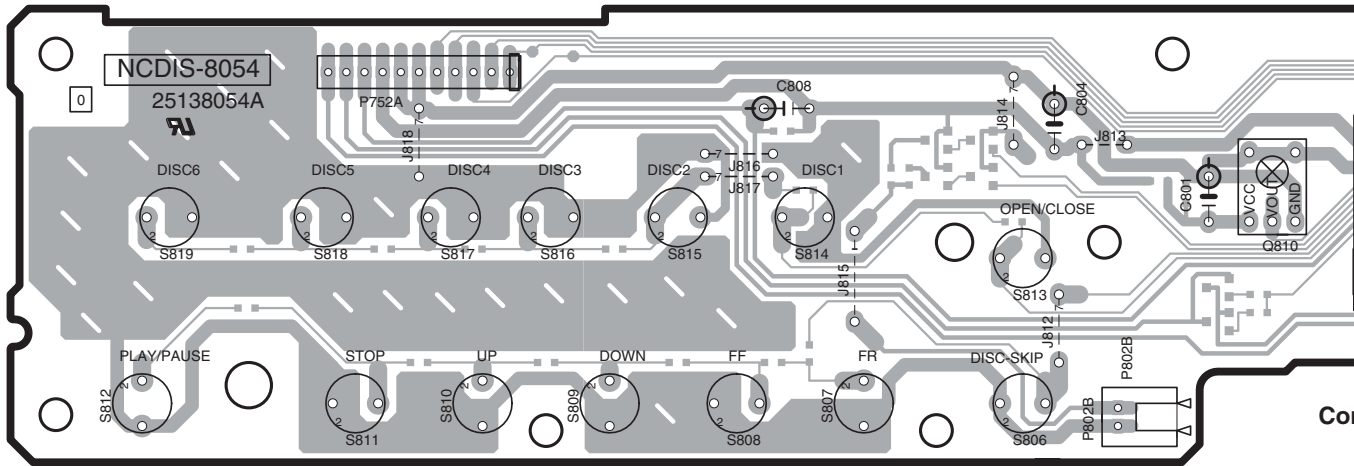



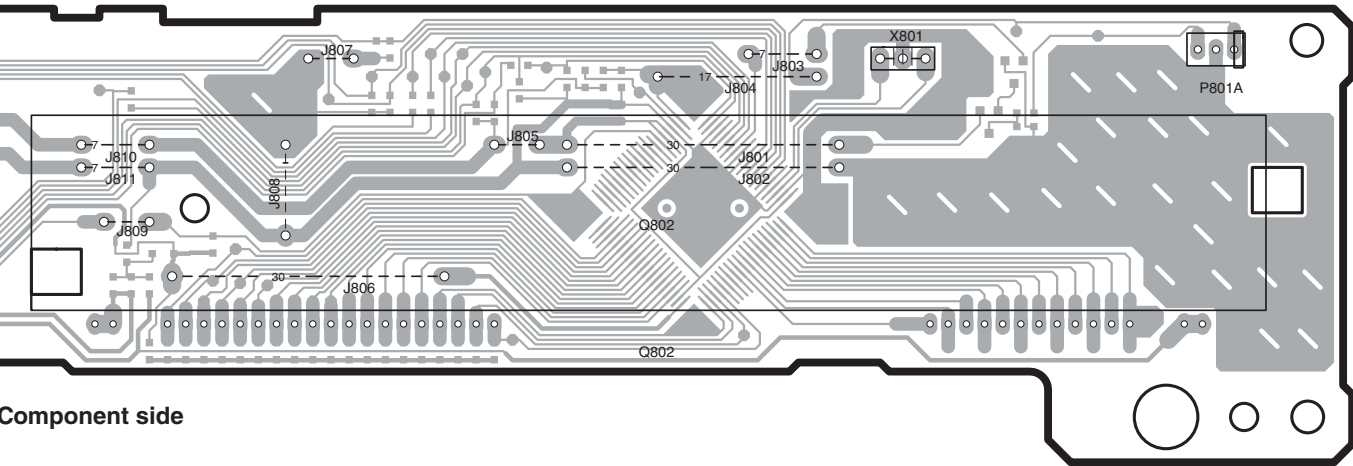

**Component side**

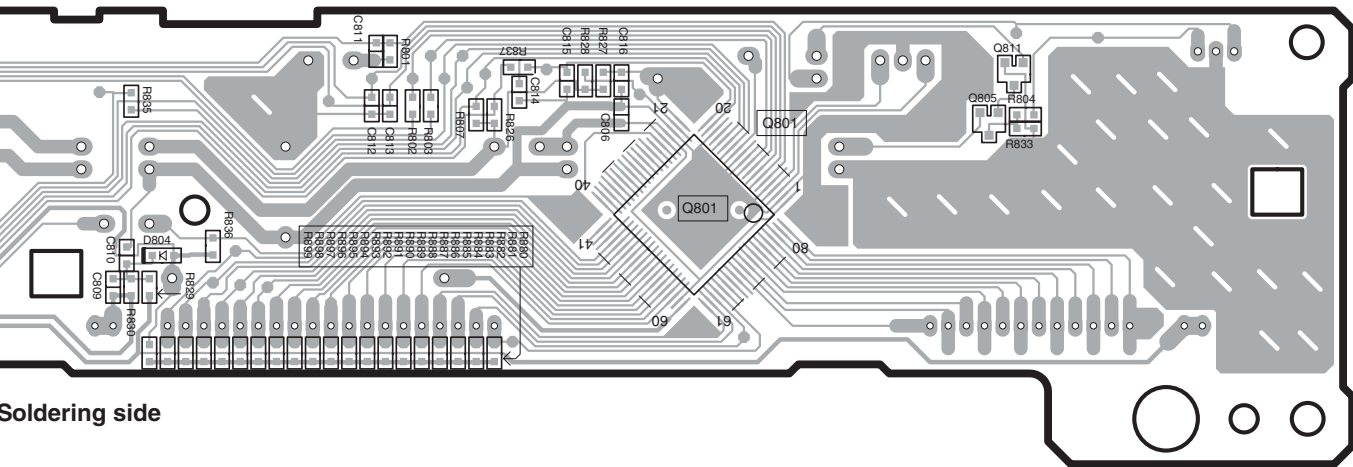

**Soldering side**

# PRINTED CIRCUIT BOARD VIEW FROM SOLDERING SIDE-3

## U23 : MECHANISM CONTROL PC BOARD NADG-8057

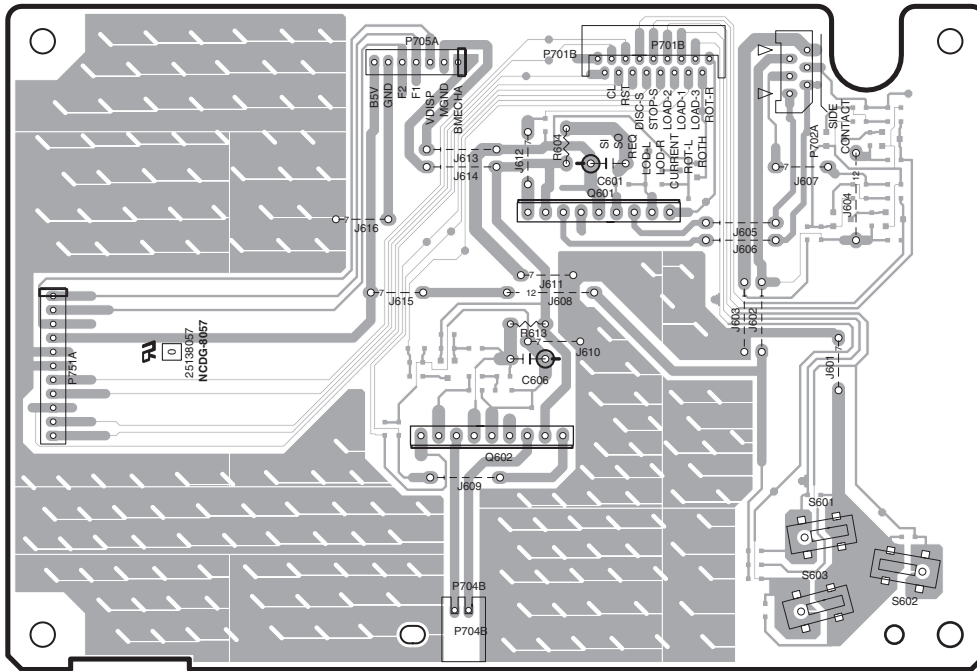

Component side

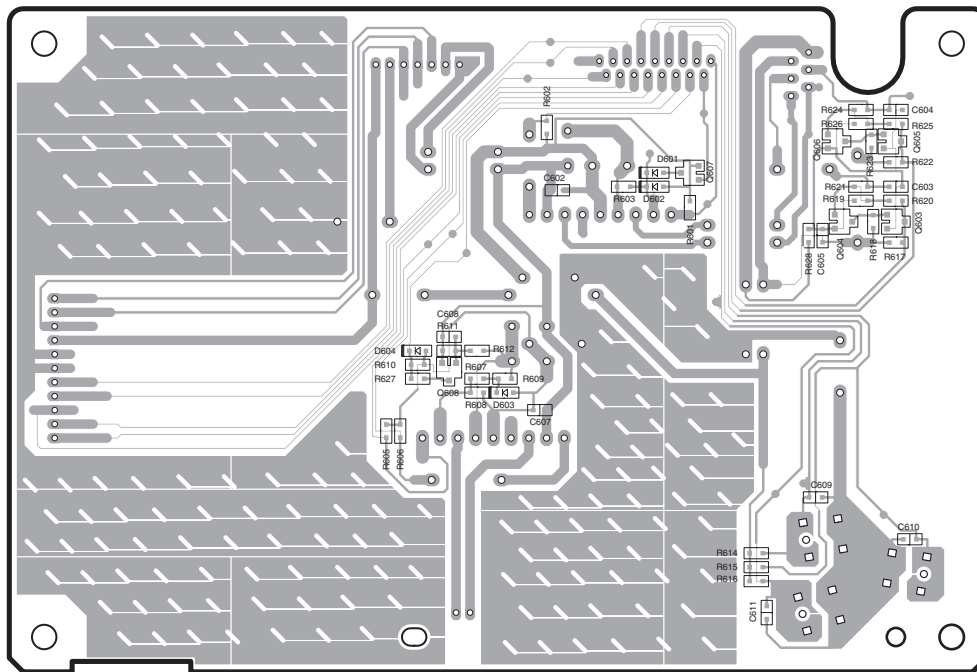

Soldering side

PRINTED CIRCUIT BOARD VIEW FROM SOLDERING SIDE-4

**U26**: ROULETTE MOTOR PC BOARD NAETC-8060



**U27**: LOADING MOTOR PC BOARD NAETC-8061

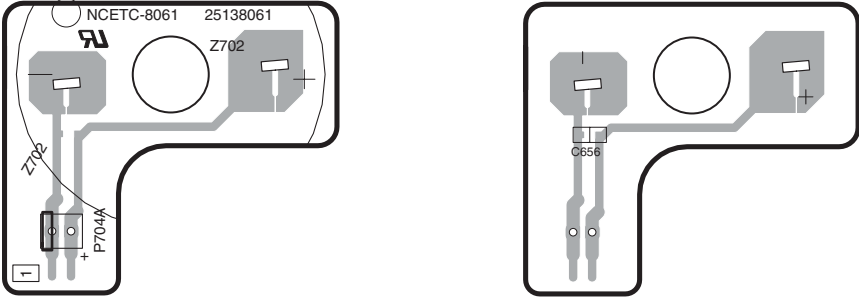

**U28**: CONNECTION PC BOARD  
NAETC-8062

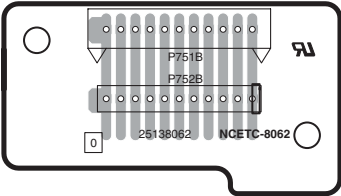

**U30**: POWER SWITCH PC BOARD  
NASW-8063 <MPP> <MPA> ONLY

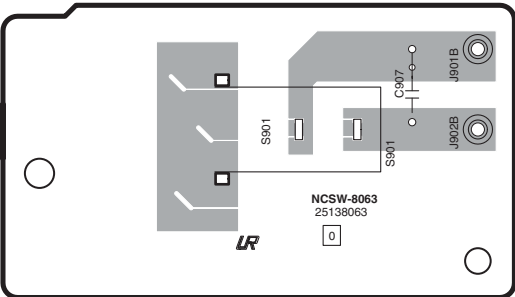

# PRINTED CIRCUIT VIEW FROM SOLDERING SIDE-5

## U21: STANDBY LED PC BOARD NASW-8055

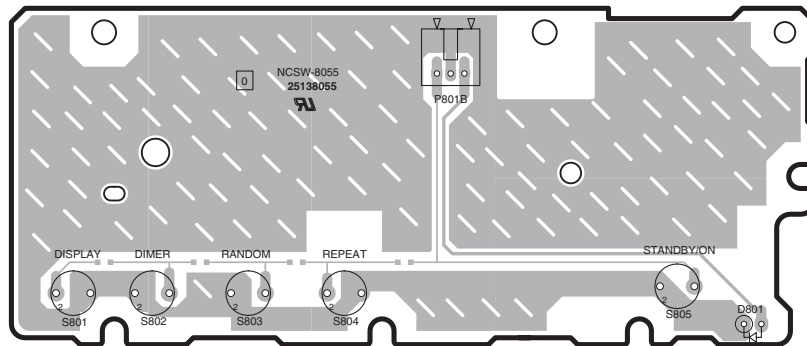

Component side

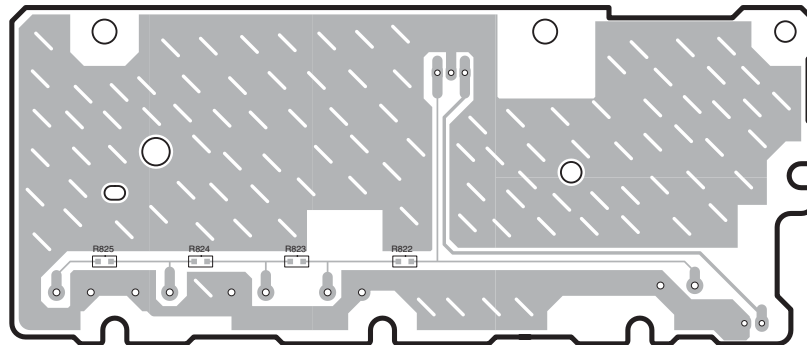

Soldering side

## U29: ILLUMINATION PC BOARD NADIS-8066

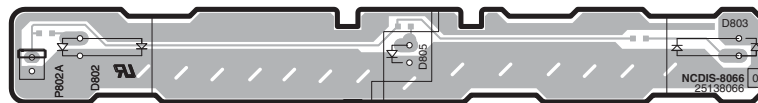

Component side

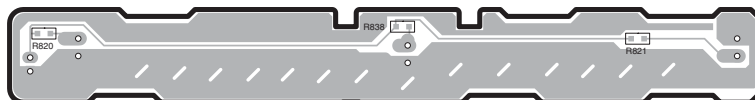

Soldering side

**PRINTED CIRCUIT BOARD VIEW FROM SOLDERING SIDE-6**

**U24: POWER TRANSFORMER PC BOARD NAPS-8058**

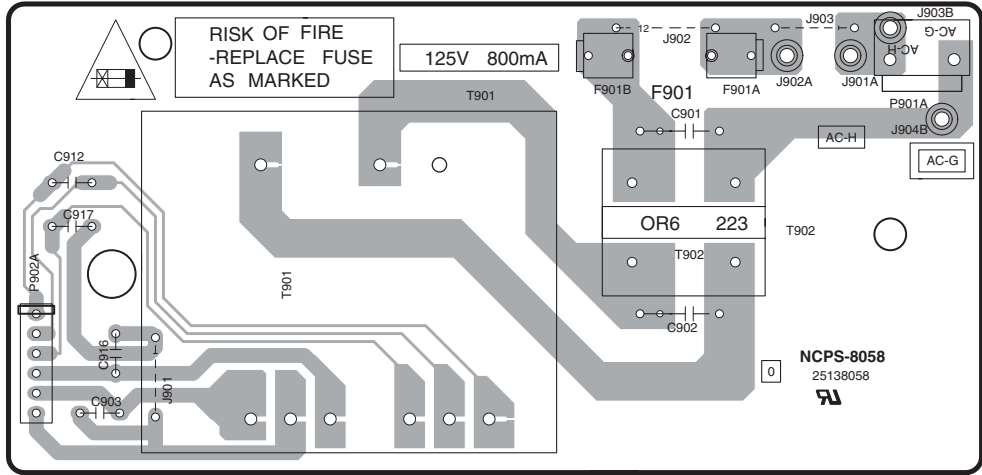

**U25: DISC SENSOR PC BOARD NAETC-8059**

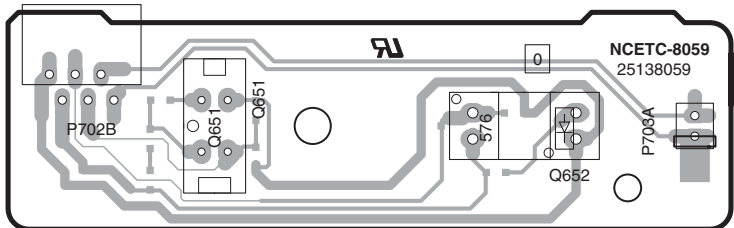

**Component side**

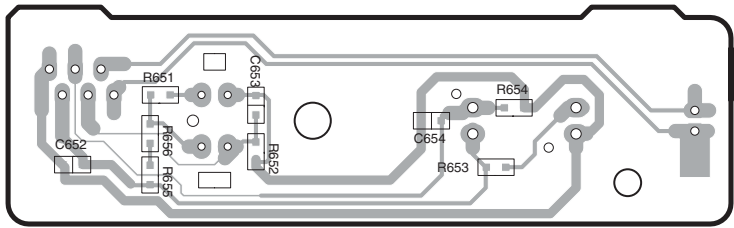

**Soldering side**



**PRINTED CIRCUIT VIEW FROM SOLDERING SIDE-7**

**U22: OUTPUT TERMINAL PC BOARD NAAR-8056**

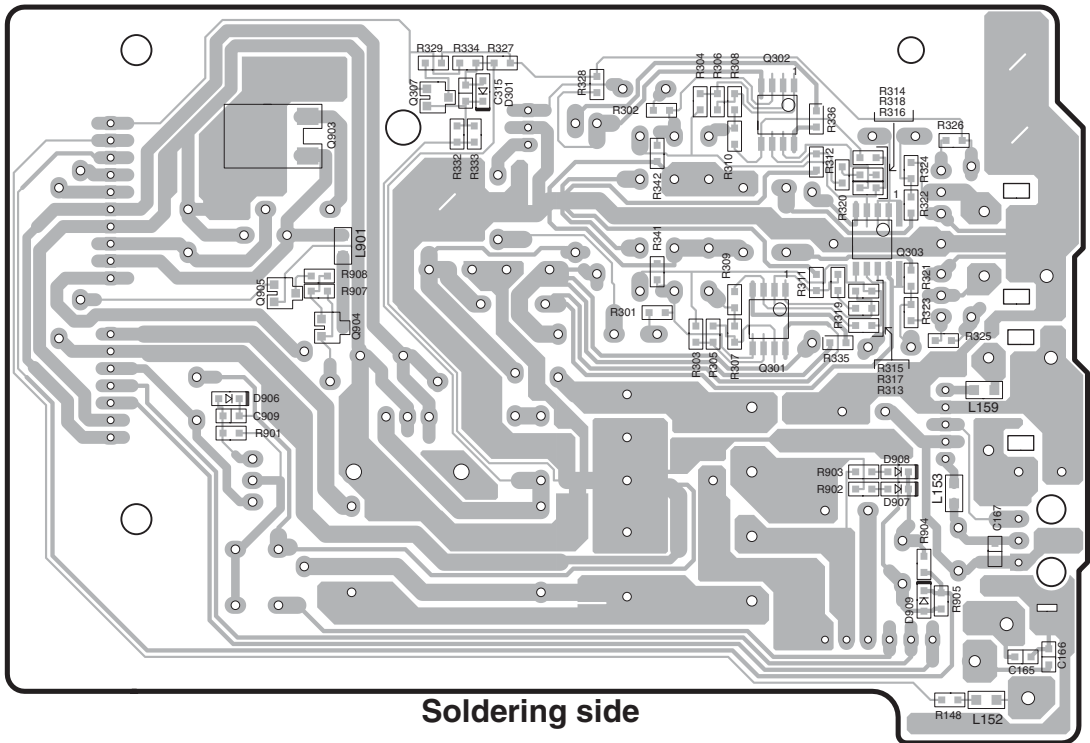
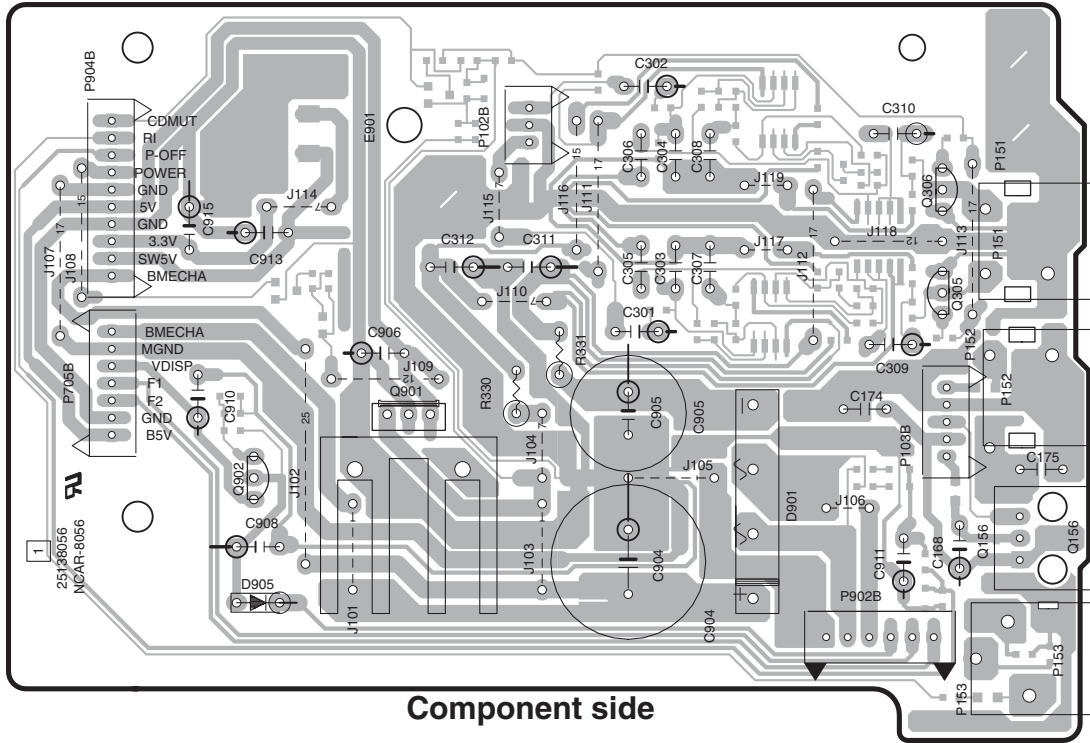

# IC BLOCK DIAGRAM/TERMINAL DESCRIPTION

## Q551 : AK4103VF DIGITAL AUDIO TRANSMITTER

### PIN LAYOUT

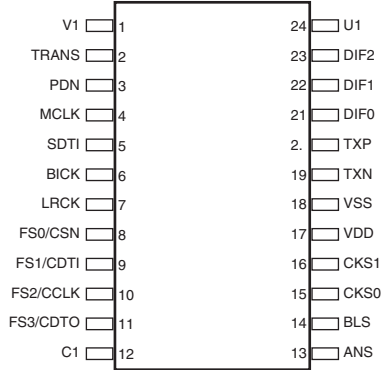

### BLOCK DIAGRAM

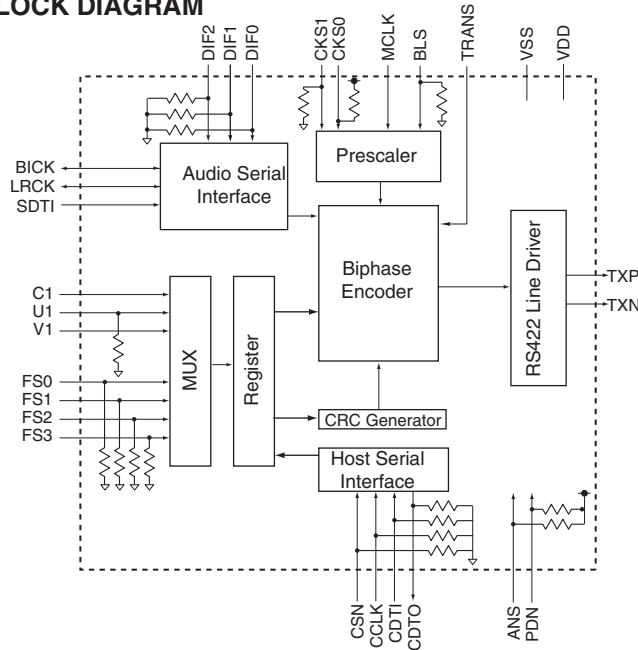

### PIN / FUNCTION

No.	PIN NAME	I/O	DESCRIPTION
1	V1	I	Validity bit input pin
2	TRANS	I	Audio routing mode (transparent mode) pin at synchronous mode. 0: Normal mode, 1: Audio routing mode
3	PDN	I	Power down & reset pin. When "L", the AK4103 is powered-
4	MCLK	I	Master clock input pin.
5	SDTI	I	Audio serial data input pin.
6	BICK	I/O	Audio serial data clock input/ output pin.
7	LRCK	I/O	Input output channel clock pin.
8	FS0	I	Sampling frequency select 0 pin at synchronous mode.
	CSN	I	Host interface chip select pin at asynchronous mode.
	AKMODE	I	AK4112A: mode pin at audio routing mode.
9	FS1	I	Sampling frequency select 1 pin at synchronous mode.
	CDTI	I	Host interface data input pin at asynchronous mode.
10	FS2	I	Sampling frequency select 2 pin at synchronous mode.
	CCLK	I	Host interface bit clock input pin at asynchronous mode.
11	FS3	I	Sampling frequency select 3 pin.
	CDTI	O	Host interface data output pin.
12	C1	I	Channel status bit input pin.
13	ANS	I	Asynchronous/synchronous mode select pin. 1: synchronous
14	BLS	I/O	Block start input/output pin.
15	CKS0	I	Clock mode select 0 pin.
16	CKS1	I	Clock mode select 1 pin.
17	VDD	-	power supply pin. 4.75 to 5.25V
18	VSS	-	Ground pin.
19	TXN	O	Negative differential output pin.
20	TXP	O	Positive differential output pin.
21	DIF0	I	Audio serial input select 0 pin.
22	DIF1	I	Audio serial input select 1 pin.
23	DIF2	I	Audio serial input select 2 pin.
24	U1	I	User data bit input for channel 1.

IC BLOCK DIAGRAM/TERMINAL DESCRIPTION

Q155 : TC74VHCU04FT (Hex inverter)

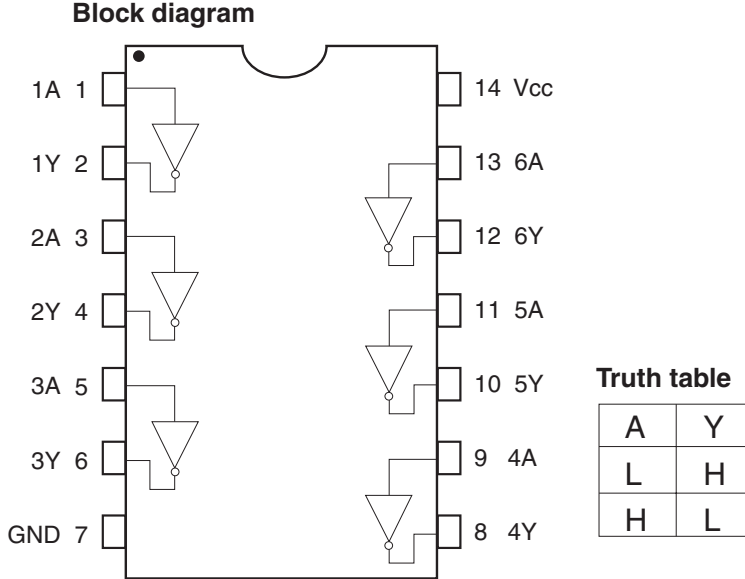

## IC BLOCK DIAGRAM/TERMINAL DESCRIPTION

### Q601, Q602 : TA7291S (MOTOR DRIVER)

#### BLOCK DIAGRAM

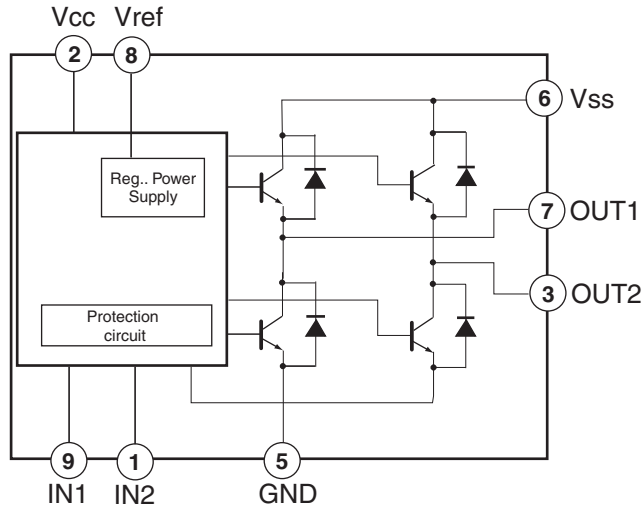

Truth table

INPUT		OUTPUT		MODE
IN1	IN2	OUT1	OUT2	
0	0	$\infty$	$\infty$	STOP
1	0	H	L	CW/CCW
0	1	L	H	CCW/CW
1	1	L	L	BRAKE

CW: Clockwise direction  
CCW: Counter clockwise direction

#### PIN FUNCTION

PIN No.	SYMBOL	FUNCTION DESCRIPTION
2	Vcc	Supply voltage terminal for Logic.
6	VS	Supply voltage terminal for Motor drive.
8	Vref	Supply voltage terminal for control.
5	GND	GND
9	IN1	Input
1	IN2	Input
7	OUT1	Output
3	OUT2	Output

Pin 4 : NC

# IC BLOCK DIAGRAM/TERMINAL DESCRIPTION

## Q501 : LC78683E MP3 DECODER FOR CD

### BLOCK DIAGRAM

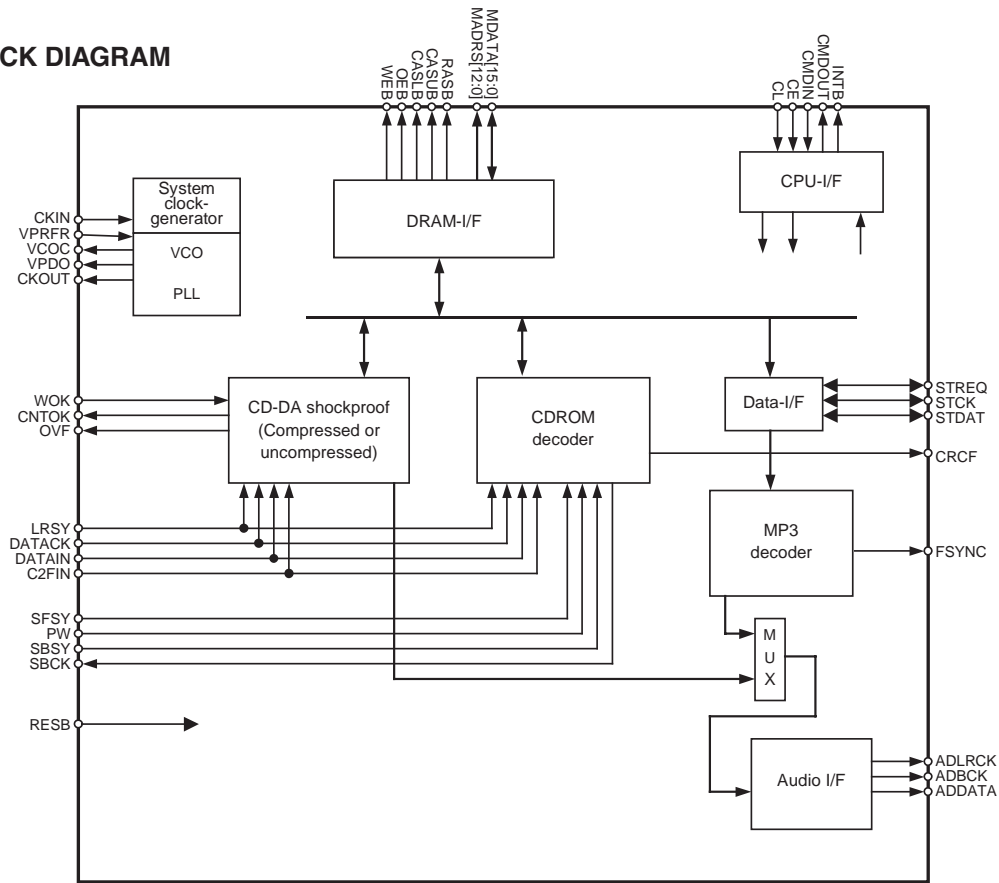

### PIN ASSIGNMENT

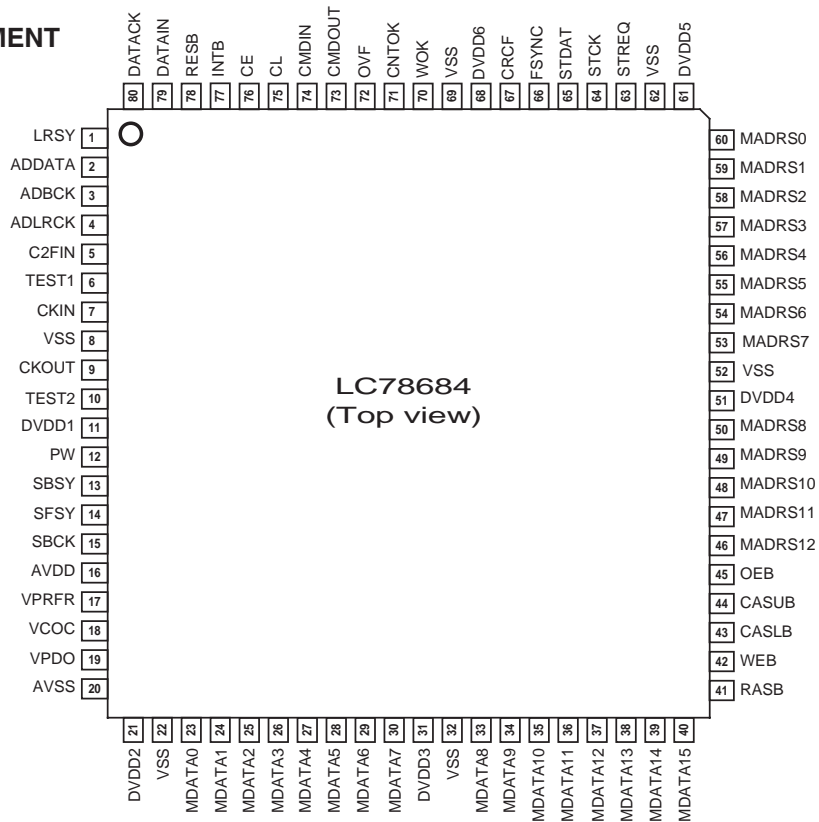

# IC BLOCK DIAGRAM/TERMINAL DESCRIPTION

## Q501 : LC78683E MP3 DECODER FOR CD

### Pin Functions

Pin No.	Pin Name	I/O	Block	Function
1	LRSY	I	CD IF	CD left/right clock input
2	ADDATA	O	Audio interface	Audio data output
3	ADBACK	O		Audio bit clock output
4	ADLRCK	O		Audio left/right clock output
5	C2FIN	I		CD IF
6	TEST1	I	Test	Test input 1 (This pin must be connected to ground during normal operation.)
7	CKIN	I	CLOCK	System clock input (16.9344 MHz)
8	VSS		Power supply	Ground
9	CKOUT	O	CLOCK	External digital filter and D/A converter clock (384 fs) output
10	TEST2	I	Test	Test input 2 (This pin must be connected to ground during normal operation.)
11	DV <sub>DD1</sub>		Power supply	Digital I/O system power supply
12	PW	I	Subcode interface	CD subcode data serial input
13	SBSY	I		CD subcode block sync signal input
14	SFSY	I		CD subcode frame sync signal input
15	SBCK	O		CD subcode transfer serial clock output
16	AV <sub>DD</sub>		Power supply	Analog system (PLL) power supply
17	VPRFR		PLL	VCO oscillator range setting
18	VCOC	I		VCO control voltage input
19	VPDO	O		VCO charge pump output
20	AVSS		Analog system ground	Analog system ground
21	DV <sub>DD2</sub>		Power supply	Internal logic system power supply
22	VSS			GND
23	MDATA0	I/O	Memory interface	DRAM data bus 0
24	MDATA1	I/O		DRAM data bus 1
25	MDATA2	I/O		DRAM data bus 2
26	MDATA3	I/O		DRAM data bus 3
27	MDATA4	I/O		DRAM data bus 4
28	MDATA5	I/O		DRAM data bus 5
29	MDATA6	I/O		DRAM data bus 6
30	MDATA7	I/O		DRAM data bus 7
31	DV <sub>DD3</sub>		Power supply	Digital I/O system power supply
32	VSS			GND
33	MDATA8	I/O	Memory interface	DRAM data bus 8
34	MDATA9	I/O		DRAM data bus 9
35	MDATA10	I/O		DRAM data bus 10
36	MDATA11	I/O		DRAM data bus 11
37	MDATA12	I/O		DRAM data bus 12
38	MDATA13	I/O		DRAM data bus 13
39	MDATA14	I/O		DRAM data bus 14
40	MDATA15	I/O		DRAM data bus 15
41	RASB	O		RAS output (active low)
42	WEB	O		WE output (active low)
43	CASLB	O		CAS output (lower byte, active low)
44	CASUB	O		CAS output (upper byte, active low)
45	OEB	O		OE output (active low)
46	MADRS12	O		DRAM address output 12
47	MADRS11	O		DRAM address output 11
48	MADRS10	O	DRAM address output 10	
49	MADRS9	O	DRAM address output 9	
50	MADRS8	O	DRAM address output 8	

Continued on next page.

## IC BLOCK DIAGRAM/TERMINAL DESCRIPTION

### Q501 : LC78683E MP3 DECODER FOR CD

Continued from preceding page.

Pin No.	Pin Name	I/O	Block	Function
51	DV <sub>DD4</sub>		Power supply	Digital I/O system power supply
52	V <sub>SS</sub>			Ground
53	MADRS7	O	Memory interface	DRAM address output 7
54	MADRS6	O		DRAM address output 6
55	MADRS5	O		DRAM address output 5
56	MADRS4	O		DRAM address output 4
57	MADRS3	O		DRAM address output 3
58	MADRS2	O		DRAM address output 2
59	MADRS1	O		DRAM address output 1
60	MADRS0	O		DRAM address output 0
61	DV <sub>DD5</sub>		Power supply	Internal logic system power supply
62	V <sub>SS</sub>			GND
63	STREQ	I/O	MP3 stream I/O	MP3 data request flag output (active high) /DRAM data request flag input (CD-ROM mode, active high)
64	STCK	I/O		MP3 data transfer clock input /DRAM data transfer clock output
65	STDAT	I/O		MP3 serial data input /DRAM serial data output
66	FSYNC	O	MP3-dec	MP3 frame sync signal (active high) /Data continuity point detection complete flag (CD-DA mode, active high)
67	CRCF	O	CD monitor	CRC check result output (CD-ROM data/CD-DA subcode data) /DRAM data output enable signal output (active high)
68	DV <sub>DD6</sub>		Power supply	Digital I/O system power supply
69	V <sub>SS</sub>			GND
70	WOK	I	CD-DA shockproof and MP3 I/O	DRAM write enable input (CD-DA mode, active high) /DRAM data request flag input
71	CNTOK	O		Data continuity point detection complete flag (CD-DA mode, active high) /SYNC error monitor flag (MP3 mode, active high)/DRAM serial data output
72	OVF	O		DRAM write interrupt flag (CD-DA mode, active high) /Emphasis output flag (CD-DA and MP3 modes, active high) /DRAM data transfer clock output
73	CMDOUT	O	Microcontroller interface	Serial command data output (n-channel open-drain output)
74	CMDIN	I		Serial command data input
75	CL	I		Serial command clock input
76	CE	I		Command enable input (active high)
77	INTB	O		Interrupt signal output (active low) /DRAM write interrupt flag (CD-DA mode, active high)
78	RESB	I		System reset (active low)
79	DATAIN	I	CD IF	Serial CD data input
80	DATACK	I		CD bit clock input

Notes: 1. Notes on unused pins.

Unused input pins must be connected to the ground level (0 V).

Unused output pins must be left open. Do not connect anything to these pins.

Unused I/O pins may either be connected to the ground level (0 V) or set to output mode and left open.

2. The corresponding power supply levels must be provided to all of the DV<sub>DD1</sub>, DV<sub>DD3</sub>, DV<sub>DD4</sub>, DV<sub>DD6</sub>, and AV<sub>DD</sub> pins. The corresponding power supply level must also be provided to DV<sub>DD2</sub> and DV<sub>DD5</sub>. (See the Allowable Operating Ranges specifications for the supply levels.)

3. The TEST1 and TEST2 input pins must be connected to ground (0 V).

4. The I/O pins (MDAT0:15, STREQ, STCK, and STDAT) go to input mode after a reset.

5. After first applying the power supply levels, the RESB pin must be held low for at least 1  $\mu$ s.

6. A 16.9344 MHz clock signal must be supplied to the CKIN pin by the CD DSP.

The LC78684E does not support the implementation of an oscillator circuit using an oscillator element.

# IC BLOCK DIAGRAM/TERMINAL DESCRIPTION

80 pin QFP

## Q103 : CXD3068Q DIGITAL SIGNAL PROCESSOR-1

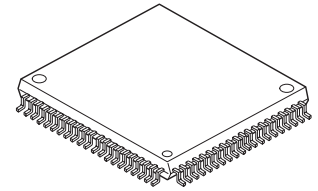

### BLOCK DIAGRAM

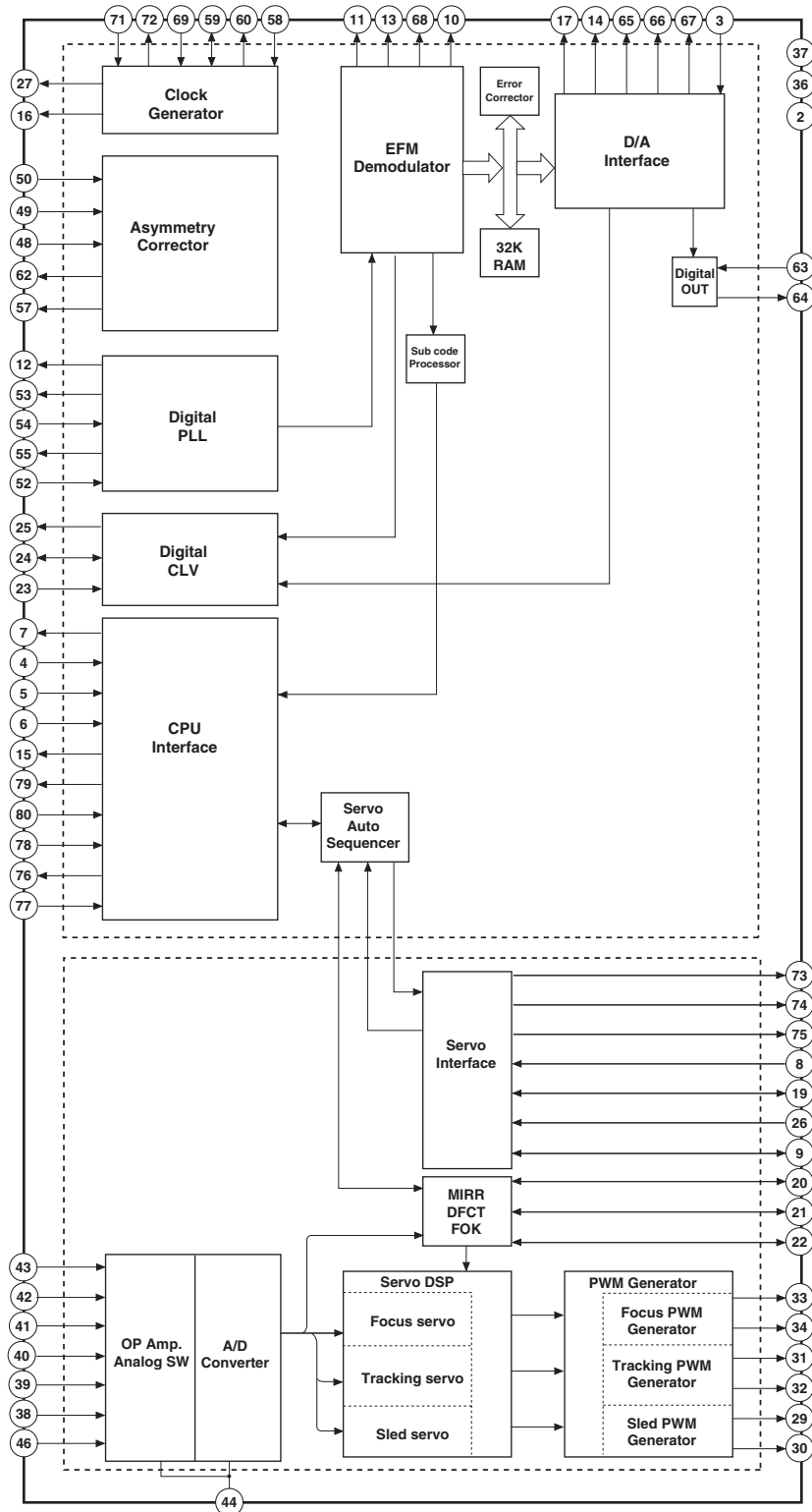



## IC BLOCK DIAGRAM/TERMINAL DESCRIPTION

### Q103 : CXD3068Q DIGITAL SIGNAL PROCESSOR-2

#### PIN DESCRIPTION

No.	SIGN	I/O	DESCRIPTION
1	DVDD0	-	Digital power supply terminal.
2	XRST	I	System reset pin. L= Reset
3	MUTE	I	Mute input pin. H= Mute
4	DATA	I	Serial data input pin from CPU.
5	XLAT	I	Latch signal input pin from CPU.
6	CLOCK	I	The clock input pin for transmission of serial data.
7	SENS	O	SENS signal output pin for CPU.
8	SCLK	I	The clock input for reading of serial data.
9	ATSK	I/O	Input/ output pin for anti-shock.
10	WFCK	O	WFCK output pin.
11	XUGF	O	XUGF output pin.
12	XPCK	O	XPCK output pin.
13	GFS	O	GFS output pin.
14	C2PO	O	C2PO output pin.
15	SCOR	O	When detected the sub code sink S0 or S1, outputting is "H".
16	C4M	O	4.2336M Hz output pin.
17	WDCK	O	Word clock output pin. F=2Fs.
18	DVss0	-	Digital ground.
19	COUT	I/O	The number of count signal input and output of tracks
20	MIRR	I/O	Mirror signal output/ input pin.
21	DFCT	I/O	Defect signal output/ input pin.
22	FOK	I/O	Focus OK signal output/ input pin.
23	PWM1	I	Outer edge control pin of spindle motor.
24	LOCK	I/O	GFS is sampled by 460Hz, When GFS is "H", outputting is "H". When GFS is eight consecutive time "L." outputting is "L".
25	MPD	O	Servo control output pin for spindle motor.
26	SSTP	I	The detected signal input inside a disk
27	FSTO	O	2/3 divided signal output pin of XTAL terminal.
28	DVDD1	-	Digital power supply.
29	SFDR	O	Sled drive output pin.
30	SRDR	O	Sled drive output pin.
31	TFDR	O	Tracking drive output pin.
32	TRDR	O	Tracking drive output pin.
33	FFDR	O	Focus drive output pin.
34	FRDR	O	Focus drive output pin.
35	DVss1	-	Digital GND.
36	TEST	I	Test pin. (To connect the GND)
37	TES1	I	Test pin. (To connect the GND)
38	VC	I	Center voltage input pin.
39	FE	I	Focus error signal input pin.
40	SE	I	Sled error signal input pin.

## IC BLOCK DIAGRAM/TERMINAL DESCRIPTION

### Q103 : CXD3068Q DIGITAL SIGNAL PROCESSOR-3

#### PIN DESCRIPTION

No.	SIGN	I/O	DESCRIPTION
41	TE	I	Tracking error input pin.
42	CE	I	Center servo analog signal input pin.
43	RFDC	I	RF signal input pin.
44	ADIO	O	Test pin.
45	AVSS0	-	Analog GND.
46	IGEN	I	Regulated power supply pin for OP-Amp.
47	AVDD0	-	Analog power supply.
48	ASYO	O	EFM full swing output pin. L= VSS, H= VDD
49	ASYI	I	The input pin of cooperate voltage of asymmetry.
50	RFAC	I	EFM signal input pin.
51	AVSS1	-	Analog GND.
52	CLTV	I	VCO1 control voltage input pin.
53	FILO	O	Filter circuit output pin for master PLL.
54	FILI	I	Filter circuit input pin for master PLL.
55	PCO	O	Change pump circuit output pin for master PLL.
56	AVDD1	-	Analog power supply.
57	BIAS	I	The constant current input of an asymmetry circuit
58	VCTL	I	VCO2 control voltage input pin for EFM PLL.
59	V16M	I/O	VCO2 osculation output pin for EMF PLL.
60	VPCO	O	Charge pump output pin for EMF PLL.
61	DVDD2	-	Digital power supply.
62	ASYE	I	Select ON/OFF of asymmetry circuit. L= OFF, H= ON
63	MD2	I	Digital output control pin. L= OFF, H= ON
64	DOUT	O	Digital output pin.
65	LRCK	O	D/A interface output pin. LR clock output.
66	PCMD	O	D/A interface output pin. Serial data output.
67	BCK	O	D/A interface output pin. Bit clock output.
68	EMPH	O	When detect the emphasis on the disc, outputting is "H".
69	XTSL	I	X'tal select input pin. 16.9344MHz= L, 33.8688MHz= H
70	DVSS2	-	Digital GND.
71	XTAI	I	Input pin for connect the crystal OSC.
72	XTAO	O	Output pin for connect the crystal OSC.
73	SOUT	O	Serial data output pin.
74	SOCK	O	Clock signal of reading serial data output pin.
75	XOUT	O	Serial latch output pin.
76	SQSO	O	Peak level data output pin.
77	SQCK	I	Clock signal output pin for SQSO read out.
78	SCSY	I	Input pin of GRSCOR.
79	SBSO	O	Serial output pin for Sub P to Sub W.
80	EXCK	I	Clock input pin for SBSO read out.

## IC BLOCK DIAGRAM/TERMINAL DESCRIPTION

### Q102 : CXA2851N RF SIGNAL PROCESSOR

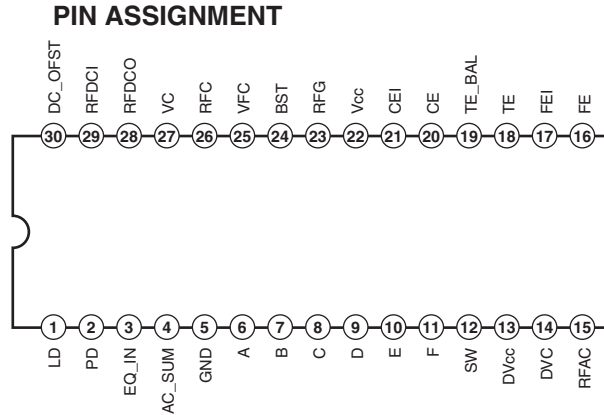

#### Terminal Description

PIN No.	PIN SIGN	I/O	DESCRIPTION
1	LD	O	Output pin for APC amp.
2	PD	I	Input pin for APC amp.
3	EQ_IN	I	Input pin for EQ block and VCA block of RFAC system.
4	AC_SUM	O	Output pin for RF SUM of RF AC system.
5	GND	I	GND pin
6	A	I	A-signal input pin.
7	B	I	B-signal input pin.
8	C	I	C-signal input pin.
9	D	I	D-signal input pin.
10	E	I	E-signal input pin.
11	F	I	F-signal input pin.
12	SW	I	Mode select input pin.
13	DVcc	I	DVcc input pin.
14	DVC	O	DVcc output pin.
15	RFAC	O	RFAC signal output pin.
16	DC_OFST	O	Focus error signal output pin.
17	RFDCI	I	Virtual grounding pin of FE Amp.
18	RFDCO	O	Tracking error signal output pin.
19	VC	I	TE balance adjusting pin.
20	RFC	O	Center error signal output pin.
21	VFC	I	Virtual grounding pin of CE Amp.
22	BST	I	Vcc pin.
23	RFG	I	AF signal gain adjusting pin of VCA block.
24	Vcc	I	Adjust the boost quantity of EQ.
25	CEI	I	Adjust the cutoff frequency signal of EQ.
26	CE	I	Adjust the cutoff frequency signal of EQ.
27	TE_BAL	O	VC voltage output pin.
28	TE	O	RFDC signal output pin.
29	FEI	I	Virtual grounding pin of RFDC Amp.
30	FE	I	Offset adjusting output pin for RFDC.

# IC BLOCK DIAGRAM/TERMINAL DESCRIPTION

## Q706 : BR93L56F-WE2 128 x 16 bit Electrically Programmable ROM-1

### ◇PIN CONFIGURATIONS

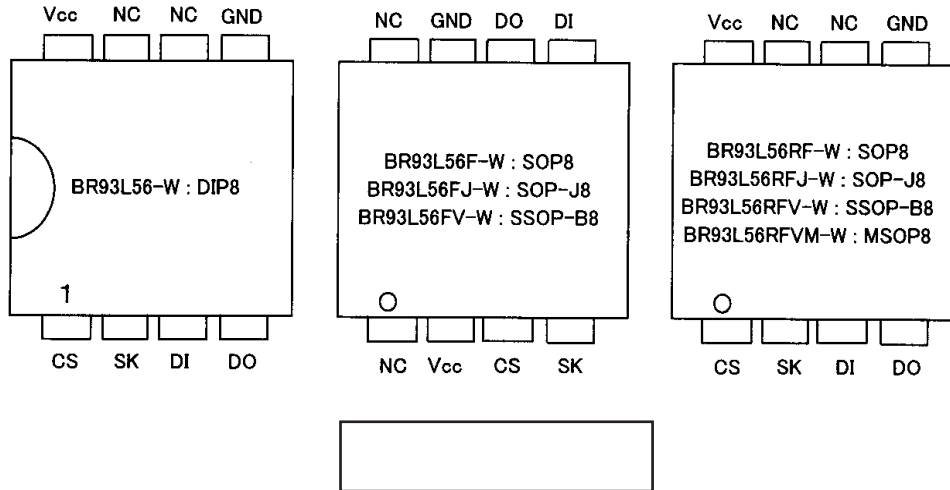

### ◇TERMINAL FUNCTION

Terminal	IN/OUT	Function
Vcc	—	Power Supply
GND	—	Ground (0V)
CS	INPUT	Chip Select Control
SK	INPUT	Serial Data Clock Input
DI	INPUT	Start Bit, Op. code, Address, Serial Data Input
DO	OUTPUT	Serial Data Output , Ready/ $\overline{\text{Busy}}$ Status Output
NC	—	No Connection (Vcc or GND or OPEN)

## IC BLOCK DIAGRAM/TERMINAL DESCRIPTION

Q706 : BR93L56F-WE2 128 x 16 bit Electrically Programmable ROM-2

### BLOCK DIAGRAM

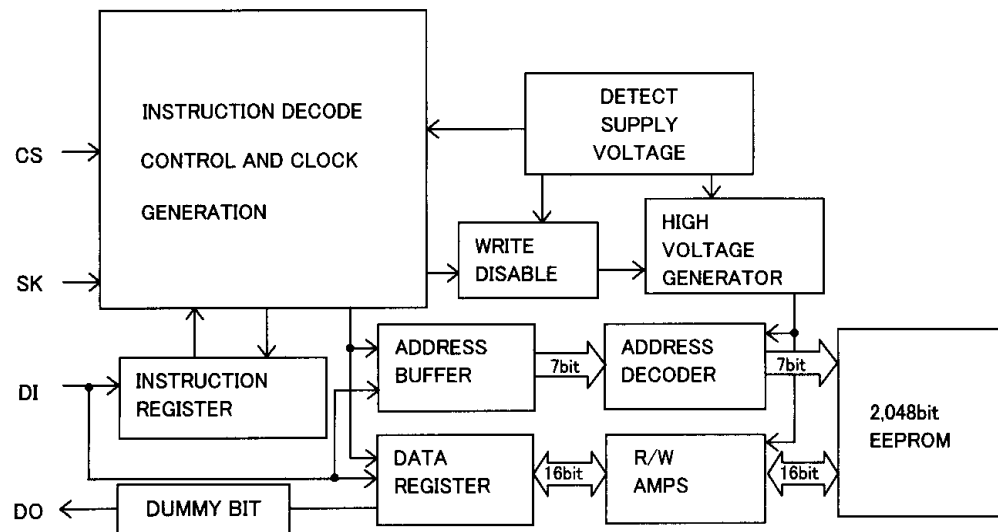

**IC BLOCK DIAGRAM / TERMINAL DESCRIPTION**

**Q201 : BA5984FP**  
**5ch BTL Driver**

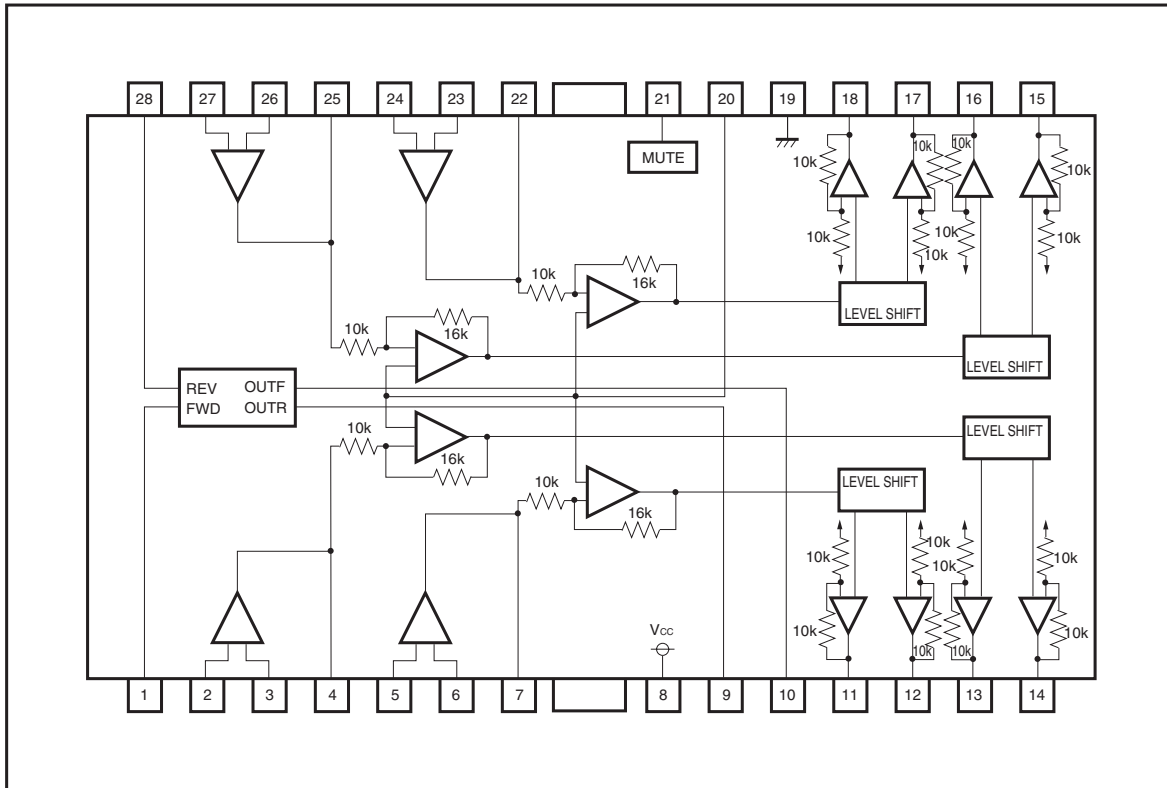

## IC BLOCK DIAGRAM / TERMINAL DESCRIPTION

### Q201 : BA5984FP

#### Terminal Description

Pin No.	Name	Description
1	FWD	Loading driver input terminal (FWD)
2	OPIN1 (+)	BTL amp. 1 input terminal (non-inverting side)
3	OPIN1 (-)	BTL amp. 1 input terminal (inverting side)
4	OPOUT1	BTL amp. 1 output terminal
5	OPIN2 (+)	BTL amp. 2 input terminal (non-inverting side)
6	OPIN2 (-)	BTL amp. 2 input terminal (inverting side)
7	OPOUT2	BTL amp. 2 output terminal
8	Vcc	Power supply terminal
9	VoL (-)	Loading driver output terminal (negative output)
10	VoL (+)	Loading driver output terminal (positive output)
11	Vo2 (-)	Driver CH2 output terminal (negative output)
12	Vo2 (+)	Driver CH2 output terminal (positive output)
13	Vo1 (-)	Driver CH1 output terminal (negative output)
14	Vo1 (+)	Driver CH1 output terminal (positive output)
15	Vo4 (+)	Driver CH4 output terminal (negative output)
16	Vo4 (-)	Driver CH4 output terminal (positive output)
17	Vo3 (+)	Driver CH3 output terminal (negative output)
18	Vo3 (-)	Driver CH3 output terminal (positive output)
19	GND	Ground terminal
20	BIAS	BIAS signal input terminal
21	MUTE	Muting control terminal
22	OPOUT3	BTL amp. 3 output terminal
23	OPIN3 (-)	BTL amp. 3 input terminal (inverting side)
24	OPIN3 (+)	BTL amp. 3 input terminal (non-inverting side)
25	OPOUT4	BTL amp. 4 output terminal
26	OPIN4 (-)	BTL amp. 4 input terminal (inverting side)
27	OPIN4 (+)	BTL amp. 4 input terminal (non-inverting side)
28	REV	Loading driver input terminal (REV side)

# IC BLOCK DIAGRAM/TERMINAL DESCRIPTION

## Q154 : UPC29L00 SERIES THREE TERMINAL VOLTAGE REGULATOR

**CONNECTION DIAGRAM**

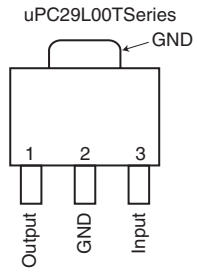

**BLOCK DIAGRAM**

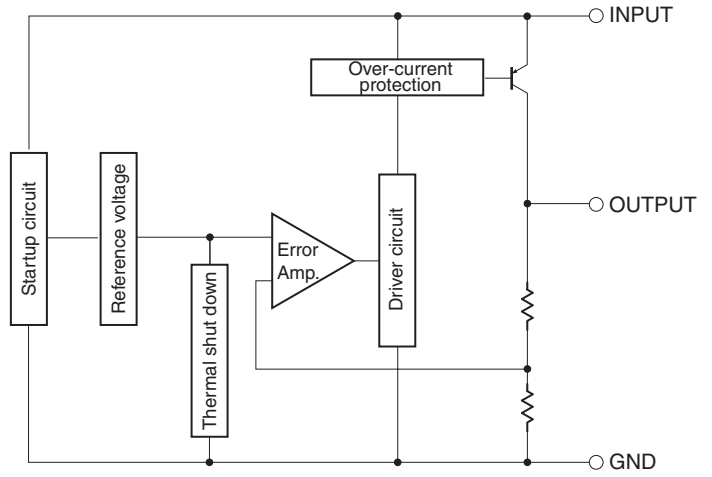



# FL TUBE VIEW

## Q802: HNV-12SM57

### GRID ASSIGNMENT

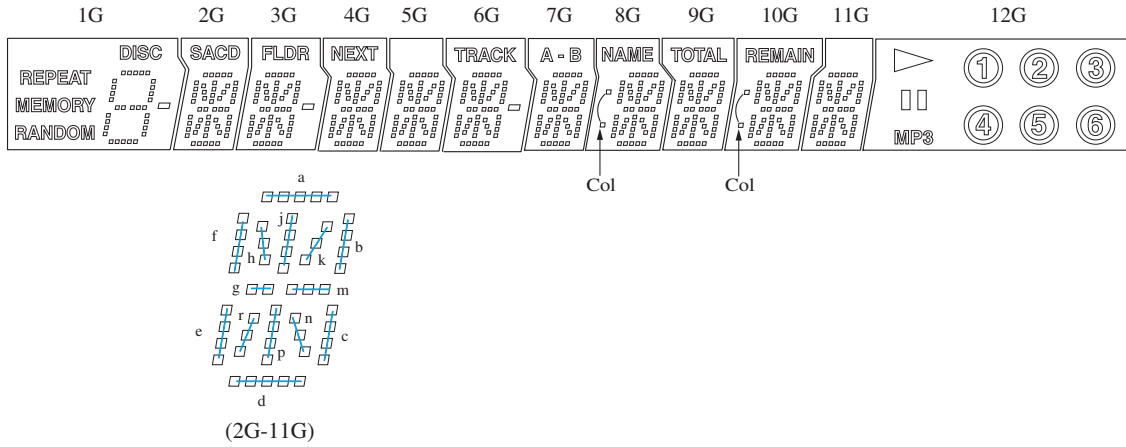

### PIN CONNECTION

PIN No.	1	2	3	4	5	6	7	8	9	10	11	12	13	14	15	16	17-39	40	41	42	43	44	45	46	47	48	49	50	51	52	53	54	55	56	57	58	59	60	61	62
CONNECTION	F1	F1	NP	NP	1G	2G	3G	4G	5G	6G	7G	8G	9G	10G	11G	12G	NX	P1	P2	P3	P4	P5	P6	P7	P8	P9	P10	P11	P12	P13	P14	P15	P16	P17	P18	P19	NP	NP	F2	F2

- 1) Fn : Filament pin
- 2) nG : Grid pin
- 3) Pn : Anode pin
- 4) NP : No Pin
- 5) NX : No extended Pin

### ANODE CONNECTION

	1G	2G	3G	4G	5G	6G	7G	8G	9G	10G	11G	12G
P1	a	a	a	a	a	a	a	a	a	a	a	1
P2	j	j	j	j	j	j	j	j	j	j	j	2
P3	h	h	h	h	h	h	h	h	h	h	h	3
P4	k	k	k	k	k	k	k	k	k	k	k	4
P5	b	b	b	b	b	b	b	b	b	b	b	5
P6	f	f	f	f	f	f	f	f	f	f	f	6
P7	g	g	g	g	g	g	g	g	g	g	g	⊙ (1)
P8	m	m	m	m	m	m	m	m	m	m	m	⊙ (2)
P9	c	c	c	c	c	c	c	c	c	c	c	⊙ (3)
P10	e	e	e	e	e	e	e	e	e	e	e	⊙ (4)
P11	n	n	n	n	n	n	n	n	n	n	n	⊙ (5)
P12	r	r	r	r	r	r	r	r	r	r	r	⊙ (6)
P13	p	p	p	p	p	p	p	p	p	p	p	MP3
P14	d	d	d	d	d	d	d	d	d	d	d	▶
P15	DISC	SACD	FLDR	NEXT		TRACK	A -	NAME	TOTAL	REMAIN		⊞
P16	REPEAT		□			□	B	Col		Col	Col	
P17	MEMORY											
P18	RANDOM											
P19	□											

## MAIN MICROPROCESSOR TERMINAL DESCRIPTION-1

80 pin QFP

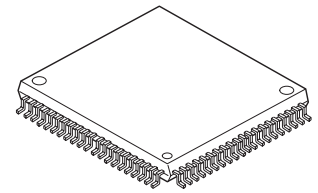

## Q701 : uPD784225GC

No.	PIN NAME	SIGNAL NAME	I/O	DESCRIPTION
1	P15/ANI5	GND	I	Not used. To connect GND pin.
2	P16/ANI6	GND	I	Not used. To connect GND pin.
3	P17/ANI7	GND	I	Not used. To connect GND pin.
4	AV <sub>ss</sub>	GND	I	GND
5	P130/ANO0		O	Not used. Open pin.
6	P131/ANO1		O	Not used. Open pin.
7	AV <sub>ref1</sub>	+5V	I	Power supply pin for A/D port.
8	P70/SI2/RxD2	RXD	I	Received pin of RS232C mode.
9	P71/SO2/TxD2	TXD	O	Output pin of RS232C mode
10	P72/-SCK2/ASCK2	GND	I	Not used. To connect GND pin.
11	P20/SI1/RxD1	MSI	I	Data input pin from MP3 decoder and sub code data form CD processor.
12	P21/SO1/TxD1	MSO	O	Transmitting data output pin to MP3 decoder and command data of CD processor.
13	P22/-SCK1/ASCK1	MSCK	O	Decoder clock output pin. Communicate to MP3 decoder.
14	P23/PCL	DOUT	O	Select the CD or MP3 output mode. L=MP3 H=CD
15	P24/BUZ	SUBRST	O	Reset signal output pin.
16	P25/SI0/SDA0	SUBSO	I	Serial data input pin from sub microprocessor.
17	P26/SO0	SUBSI	O	Serial data output pin to sub microprocessor.
18	P27/-SCK0/SCL0	SUBCL	O	Serial clock output pin to sub microprocessor.
19	P40/AD0	$\overline{\text{CDSUBQ}}$	O	Select the CD sub code output pin of serial port.
20	P41/AD1	$\overline{\text{CDCOM}}$	O	Select the CD command output pin of serial port.
21	P42/AD2	$\overline{\text{MP3COM}}$	O	Select the MP3 decoder output pin.
22	P43/AD3	$\overline{\text{MP3CE}}$	O	Chip enable signal output pin of MP3 decoder.
23	P44/AD4	SENSI	I	Sens input pin for CD signal processor.
24	P45/AD5	$\overline{\text{CDXLT}}$	O	Command latch output pin for CD signal processor.
25	P46/AD6	SCLKO	O	Sens reading clock output terminal to CD signal processor.
26	P47/AD7	FOKI	I	FOK signal input pin from signal processor.
27	P50/A8	LDON	O	Laser light control output pin. HiZ=OFF L=CD H=CD-RW
28	P51/A9	$\overline{\text{CDRESET}}$	O	Reset pin of MP3 decoder.
29	P52/A10	CDPOWER	O	Power supply control pin.
30	P53/A11	CDMUT	O	Analog mute pin. H=OFF/L=ON
31	P54/A12	STOP_POS_SEN	I	Detection the sensor input pin for disc position.
32	P55/A13	DISC_SENS	I	Disk existence detection optical sensor input terminal.
33	V <sub>ss1</sub>	GND	I	GND
34	P56/A14	$\overline{\text{ROT_R}}$	O	Roulette motor control pin-R.
35	P57/A15	$\overline{\text{ROT_L}}$	O	Roulette motor control pin-L.
36	P60/A16	ROTHI	O	Roulette motor speed control terminal..
37	P61/A17	LOADING_SW1	I	Loading clamp position detection switch input terminal 1.
38	P62/A18	LOADING_SW2	I	Loading clamp position detection switch input terminal 2.
39	P63/A19	LOADING_SW3	I	Loading clamp position detection switch input terminal 3.
40	P64/-RD	$\overline{\text{CURRENT}}$	I	Loading clamp motor current detection input terminal.
41	P65/-WR	$\overline{\text{LOADING_L}}$	O	Loading clamp motor control terminal L.
42	P66/-WAIT	$\overline{\text{LOADING_R}}$	O	Loading clamp motor control terminal R.
43	P67/ASTB		O	Not used. Open pin.
44	P30/TO0		O	Not used. Open pin.
45	P31/TO1	DITDI	I	The serial transmission data input terminal to DIT.
46	P32/TO2	DITDO	O	The serial transmission data output terminal to DIT.
47	P33/TI1	DITCL	O	The serial data transmission data output terminal to DIT.
48	P34/TI2	DITCE	O	The control command chip enable signal output terminal of DIT.
49	P35/TIO0	$\overline{\text{DITPD}}$	O	DIT power down signal output terminal.
50	P36/TIO1	EEPROMCS	O	Chip select signal output pin of EEPROM.
51	P37/EXA	EEPROMCLK	O	Serial clock signal output pin of EEPROM.
52	P120/RTP0	EEPROMDI	O	Serial data signal output pin to EEPROM.
53	P121/RTP1	EEPROMDO	I	Serial data signal input pin from EEPROM.
54	P122/RTP2	DACMUT	O	Digital mute signal of DAC. H=ON/L=OFF



## SUB MICROPROCESSOR TERMINAL DESCRIPTION-1

## Q801 : uPD780232GC

No.	PIN NAME	SIGNAL NAME	I/O	DESCRIPTION
1	VDD1	+5V	I	Power supply pin. (To connect +5V)
2	VSS1	GND	I	GND pin.
3	X1	CLOCK	I	Connect a clock OSC pin for main system.
4	X2	CLOCK	O	Connect a clock OSC pin for main system.
5	IC	GND	I	Internal connect pin.
6	~RESET	~SUBRST	I	Reset signal input pin from main processor.
7	P27/~SCK1	SUBCL	I	Communication to main microprocessor and clock input pin for write the flash microprocessor.
8	P26/SI1	SUBSI	I	Data input pin for write the flash microprocessor.
9	P25/SO1	SUBSO	O	Data output pin for write the flash microprocessor.
10	P24/BUSY	SUBREQ	O	Communication require output pin of a main microcomputer.
11	P23	GND	I	Not used. To connect GND.
12	P22	GND	I	Not used. To connect GND.
13	P21/SO3	STANDBYLED	O	Standby LED control output pin. H=Lighting, L=Light out
14	P20/~SCK3	TRAYLED1	O	Tray lighting LED control terminal 1.H=Lighting, L=Light out
15	P00/INTP0	~IRIN	I	Remote control signal input pin.
16	P01/INTP1	TRAYLED2	O	Tray illumination LED control pin 2.
17	P02/TI		O	Not used. Open pin.
18	AVSS	GND		GND pin for A/D converter.
19	ANI3	K3	I	Key input pin.
20	ANI2	K2	I	Key input pin.
21	ANI1	K1	I	Key input pin.
22	ANI0	K0	I	Key input pin.
23	VSS0	GND	I	GND pin.
24	AVDD	+5V	I	Power supply pin for A/D converter.
25	VDD0	+5V	I	Power supply pin. (To connect +5V)
26	P64/FIP52	FLON	O	Filament power supply control pin. H=ON/L=OFF
27	P63/FIP51		O	Not used. Open pin.
28	P62/FIP50		O	Not used. Open pin.
29	P61/FIP49		O	Not used. Open pin.
30	P60/FIP48		O	Not used. Open pin.
31	P57/FIP47		O	Not used. Open pin.
32	P56/FIP46		O	Not used. Open pin.
33	P55/FIP45		O	Not used. Open pin.
34	P54/FIP44		O	Not used. Open pin.
35	P53/FIP43		O	Not used. Open pin.
36	P52/FIP42		O	Not used. Open pin.
37	P51/FIP41		O	Not used. Open pin.
38	P50/FIP40		O	Not used. Open pin.
39	P47/FIP39		O	Not used. Open pin.
40	P46/FIP38		O	Not used. Open pin.
41	P45/FIP37		O	Not used. Open pin.
42	P44/FIP36		O	Not used. Open pin.
43	P43/FIP35		O	Not used. Open pin.
44	P42/FIP34	P19	O	FL tube segment output pin 19.
45	P41/FIP33	P18	O	FL tube segment output pin 18.
46	P40/FIP32	P17	O	FL tube segment output pin 17.
47	P37/FIP31	P16	O	FL tube segment output pin 16.
48	P36/FIP30	P15	O	FL tube segment output pin 15.
49	P35/FIP29	P14	O	FL tube segment output pin 14.
50	P34/FIP28	P13	O	FL tube segment output pin 13.
51	P33/FIP27	P12	O	FL tube segment output pin 12.
52	P32/FIP26	P11	O	FL tube segment output pin 11.
53	P31/FIP25	P10	O	FL tube segment output pin 10.

## SUB MICROPROCESSOR TERMINAL DESCRIPTION-2

## Q801 : uPD780232GC

No.	PIN NAME	SIGNAL NAME	I/O	DESCRIPTION
54	P30/FIP24	P9	O	FL tube segment output pin 9.
55	FIP23	P8	O	FL tube segment output pin 8.
56	FIP22	P7	O	FL tube segment output pin 7.
57	FIP21	P6	O	FL tube segment output pin 6.
58	FIP20	P5	O	FL tube segment output pin 5.
59	VDD2	+5V		Power supply pin. (To connect +5V)
60	VLOAD	-Vdisp		Negative power supply pin.
61	FIP19	P4	O	FL tube segment output pin 4.
62	FIP18	P3	O	FL tube segment output pin 3.
63	FIP17	P2	O	FL tube segment output pin 2.
64	FIP16	P1	O	FL tube segment output pin 1.
65	FIP15		O	Not used. Open pin.
66	FIP14		O	Not used. Open pin.
67	FIP13		O	Not used. Open pin.
68	FIP12		O	Not used. Open pin.
69	FIP11	12G	O	FL tube grid output pin 12.
70	FIP10	11G	O	FL tube grid output pin 11.
71	FIP9	10G	O	FL tube grid output pin 10.
72	FIP8	9G	O	FL tube grid output pin 9.
73	FIP7	8G	O	FL tube grid output pin 8.
74	FIP6	7G	O	FL tube grid output pin 7.
75	FIP5	6G	O	FL tube grid output pin 6.
76	FIP4	5G	O	FL tube grid output pin 5.
77	FIP3	4G	O	FL tube grid output pin 4.
78	FIP2	3G	O	FL tube grid output pin 3.
79	FIP1	2G	O	FL tube grid output pin 2.
80	FIP0	1G	O	FL tube grid output pin 1.

**PACKING VIEW**

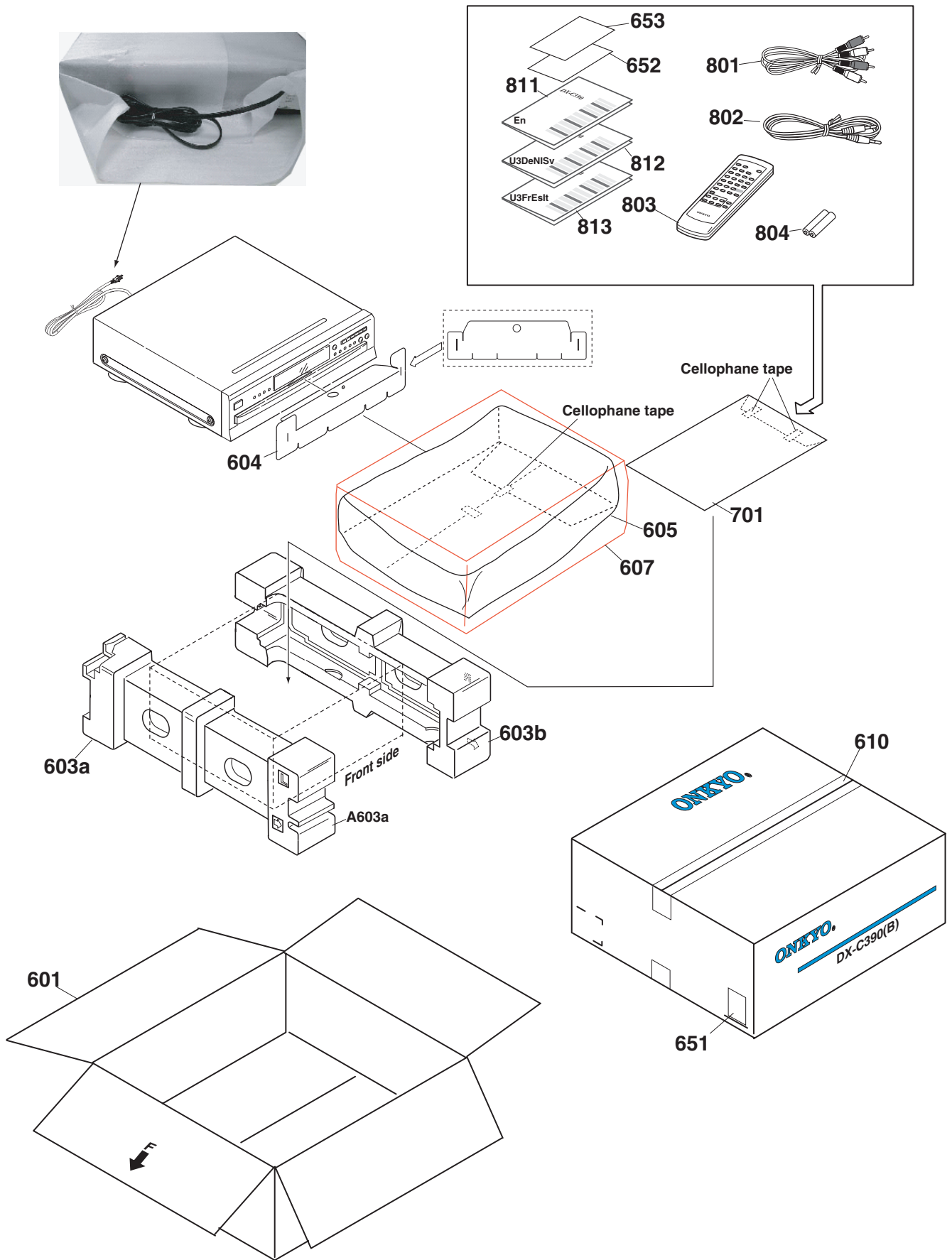

**EXPLODED VIEW PARTS LIST**

! : Safety parts

	PART NAME		PART NO.	DESCRIPTION	REMARK
A1	F BRACKET		4154-7201-1	<B>	
A1	F BRACKET		4154-7202-1	<S>	
A3	CLEAR PLT		3716-9611-0	<B>	
A3	CLEAR PLT		3716-9612-0	<S>	
A4	SHEET		3000-9707-1	(F)	
A7	BRACKET		4135-4031-1	(F)	
A9	CLIP		4135-3291-0	CS-1U	
A16	CHASSIS		1404-7611-1		
A18	HOLDER		27190428A	KGLS-10RT	
A19	CUSHION		4157-0571-0		
A20	WS CLAMP		27300243	CLAMP WS-2W	
A24	BUSHING	!	27300750	S-RELIEF #2271	
A29	SCREW		830440069	4TTC+6C(BC)	
A12	SCREW		838130088	3TTB+8B	
A37	SCREW		831430088	3TTW+8B(BC)	
A103	SCREW		838430088	3TTB+8B(BC)	
A41	LEG		27175316C	LEG	
A42	CUSHION		28141529		
A51	DOOR		4154-6121-2	(TRAY) <B>	
A51	DOOR		4154-6122-2	(TRAY) <S>	
A54	SHEET		4157-0551-0	(BUTYL)t0.75x20x20	
A55	SHEET		4157-0561-0	(BUTYL)	
A60	LABEL		3000-9670-0		
A101	REAR PANEL		1405-0802-0	<MPA,MPP>	
A101	REAR PANEL		1405-0801-0	<MDD>	
A121	HOLDER		27190011	KGLS-6S <MPP,MPA>	
A122	SCREW		838130088	3TTB+8B <MPP,MPA>	
A201	FACET		3716-9806-0	(S)	
A205	FACET		3716-9706-0	(LIGHT)	
A208	BADGE		28135244	<B>	
A208	BADGE		28135245	<S>	
A221	COVER		1404-9401-0	<B>	
A221	COVER		1404-9402-0	<S>	
A222	SCREW		838430088	3TTB+8B(BC) <B>	
A222	SCREW		838930088	3TTB+8B(UN) <S>	
A301	F PANEL		1405-0702-0	<B MPP, B MPA>	
A301	F PANEL		1405-0701-0	<B MDD>	
A301	F PANEL		1405-0703-0	<S MPP>	
A311	KNOB		2446-6401-1	(POW) <B MPP, B MPA>	
A311	KNOB		2446-6402-1	(POW) <S MPP>	
A313	JOINT		4154-7171-0	(POW) <MPP> <MPA>	
E101	WIRE TIE		260208	CLAMPER, UL	
P101	FFC		7012-6673-0	NCFC2-162512	
P102	SOCKET AS		7012-6674-0	NSAS-6P1223	
P103	SOCKET AS		7012-6671-0	NSAS-10P1224	
P201	SOCKET AS		7012-6672-0	NSAS-12P1225	
P701	FFC		7012-6670-0	NCFC5-172012	
P702	FFC		7012-6522-0	NCFC6-063012	
P901	AC CORD	!	253197HIT	AS-SAA <MPA>	
P901 or	AC CORD	!	253307VOL	AS-SAA <MPA>	
P901	AC CORD	!	253335HIT	AS-CEE <MPP>	
P901 or	AC CORD	!	253336VOL	AS-CEE <MPP>	
P901	AC CORD	!	253333VOL	AS-UC-2 <MDD>	
P901 or	AC CORD	!	253332HIT	AS-UC-2 <MDD>	
P901 or	AC CORD	!	253365LON	AS-UC-2 <MDD>	
P904	SOCKET AS		7012-6711-0	NSAS-20P1240	
T901	P TRANS	!	1806-3690-0	NPT-1480P <MPP,MPA>	
T901	P TRANS	!	1806-3861-0	NPT-1480D <MDD>	

U10	Main circuit PC board ass'y	SVC-Q0130C-MAINA	NADG-8053-1A <MDD>	
U10	Main circuit PC board ass'y	SVC-Q0130C-MAINB	NADG-8053-1B <MPP,MPA>	
U20	Display circuit PC board ass'y	SVC-Q0130C-KEY	NADIS-8054-1A <MDD>	
U20	Display circuit PC board ass'y	SVC-Q0131C-KEY	NADIS-8054-1B <MPP,MPA>	
U20-1	Display circuit PC board ass'y	1H510554-1A	NADIS-8054-1A <MDD>	
U20-1	Display circuit PC board ass'y	1H510554-1B	NADIS-8054-1B <MPP,MPA>	
U21	Standby LED PC board ass'y	1H510555-1A	NADIS-8055-1A <MDD>	
U21	Standby LED PC board ass'y	1H510555-1B	NADIS-8055-1B <MPP,MPA>	
U22	Output terminal PC board ass'y	1H510556-1A	NAAR-8056-1A <MDD>	
U22	Output terminal PC board ass'y	1H510556-1B	NAAR-8056-1B <MPP,MPA>	
U23	Mechanism control PC board ass'y	1H510557-1A	NADG-8057-1A <MDD>	
U23	Mechanism control PC board ass'y	1H510557-1B	NADG-8057-1B <MPP,MPA>	
U24	Power transformer PC board ass'y	1H510558-1A	NAPS-8058-1A <MDD>	
U24	Power transformer PC board ass'y	1H510558-1B	NAPS-8058-1B <MPP,MPA>	
U25	Disc sensor PC board ass'y	1H510559-1A	NAETC-8059-1A <MDD>	
U25	Disc sensor PC board ass'y	1H510559-1B	NAETC-8059-1B <MPP,MPA>	
U26	Roulette motor PC board ass'y	1H510560-1A	NAETC-8060-1A <MDD>	
U26	Roulette motor PC board ass'y	1H510560-1B	NAETC-8060-1B <MPP,MPA>	
U27	Loading motor PC board ass'y	1H510561-1A	NAETC-8061-1A <MDD>	
U27	Loading motor PC board ass'y	1H510561-1B	NAETC-8061-1B <MPP,MPA>	
U28	Connection PC board	1H510562-1A	NAETC-8062-1A <MDD>	
U28	Connection PC board	1H510562-1B	NAETC-8062-1B <MPP,MPA>	
U29	Illumination PC board ass'y	1H510566-1A	NADIS-8066-1A <MDD>	
U29	Illumination PC board ass'y	1H510566-1B	NADIS-8066-1B <MPP,MPA>	
U30	Power switch PC board ass'y	1H510563-1B	NASW-8063-1B <MPP,MPA>	

#### PACKING PARTS LIST

REF. NO.	PART NAME	PART NO.	DESCRIPTION	REMARK
601	CARTON	1436-5501-0-2	<B>	
601	CARTON	1436-5501-0-2	<S>	
603a	PAD	1490-4291-0	(L)	
603b	PAD	1490-4301-1	(R)	
604	SHEET	4154-6221-0	(DR)	
605	SHEET	29095949		
607	POLY BAG	29100141A	700*600	
610	PP TAPE	29110148	W48 OPP TAPE	
651	EAN LABEL	3000-9834-0	<B MPP, B MPA>	
651	UPC LABEL	3000-9836-0	<B MDD>	
651	EAN LABEL	3000-9835-0	<S MPP>	
652	WRNTY CARD	29365042	<B MPA>	
652	WRNTY CARD	29365090A	<B MDD>	
653	INST SHEET	29355299	(PAC) <B MDD>	
701	POLY BAG	29100097-1A	350*250	
801	CORD AS	2010381	PIN CORD AS	
801 or	CORD AS	2010326	PIN CORD AS	
802	PLUG CORD	2010200	3.5-MINI PLUG (RI)	
803	REMO CON	8912-0044-0	RC-547C	
804	BATTERY	3010054	R6/AA(UM-3)	
811	INS MANUAL	4301-7083-0	En <MPP,MPA,MDD>	
812	INS MANUAL	4301-7084-0	U3DeNiSv <MPP>	
813	INS MANUAL	4301-7085-0	U3FrEsIt <MPP>	

#### CHANGER MECHANISM PARTS LIST

REF. NO.	PART NAME	PART NO.	DESCRIPTION	REMARK
M1	RAIL	4154-6031-1		
M5	LOADING MOTOR AS	SVCQ0090CMOTCC	M2+M3	
(M2)	MOTOR	(8913-6002-1)	CCM07B-045R1-1	



(M3)	PULLEY	(4154-6001-0)	
M4	SCREW	833126047	2.6TTP+4S
M6	RBR BELT	4157-0281-0	DVCP701
M7	GEAR	4154-6061-0	(PULLEY)
M8	GEAR	4154-6091-0	(A)
M9	GEAR	4154-6071-0	(MAIN)
M10	GEAR	4154-6101-0	(CAM)
M11	SCREW	4135-3301-0	SCREW
M12	MECHA UNIT	24800017	KSM-213CCM
M13	CHASSIS	4154-6041-0	(SUB)
M14	INSULATOR	4154-7211-0	(CDC-A)
M16	SPRING	2510-3661-1	(CDC-A)
M17	SPRING	2510-3671-1	(CDC-B)
M18	SCREW	24840111	SCREW
M19	CAP	4154-6161-0	(CHC)
M20	YOKE	4135-3201-1	(CHB)
M21	MAGNET	4135-3211-0	(CHB)
M23	CUSHION	4157-0571-0	
M24	SPRING	2510-3591-0	(DV-CP701)
M25	RETAINER	4135-4121-1	(A)
M30	TRAY	4154-6011-3	
M31	BRACKET AS	8901-4650-0	(M)
M31a	BRACKET	8901-4650-0	(M)
M31b	SHAFT	24828038	(M)
M30	ROULETTE MOTOR AS	SVCQ0090CMOTPW	
(M32)	(MOTOR)	(8913-6003-0)	PWN10EA02D
(M33)	GEAR	(4154-6081-0)	(WORM)
M34	SCREW	82142003	2P+3F(BC)
M35	GEAR	4154-5991-0	(WHEEL)
M36	WASHER	24834040	(B)
M37	SCREW	838130088	3TTB+8B
M38	ROLLER	4154-6131-0	DVCP701
M39	ROULETTE	4154-6021-0	
M40	SCREW	24840111	SCREW
M41	TAPE	29110082-1	CLOTH-8U
M50	ARM	4154-6051-0	
M51	CUSHION	4157-0681-0	
M52	RETAINER	4135-3881-0	
M53	SCREW	838130088	3TTB+8B
M54	CUSHION	4157-0591-0	

# PRINTED CIRCUIT BOARD PARTS LIST

## U10 : MAIN CIRCUIT PC BOARD NADG-8053

!: Safety parts

	CIRCUIT NO.	PART NAME	PART NO.	DESCRIPTION	REMARK
DG8053	C101	CHIP ELECT C	356721019R2	CEWX6.3V-100M	
DG8053	C102	C-CERA C	332121045R1	CK725B1C-104K1	
DG8053	C103	C-CERA C	332103325R1	CK725B1H-332K1	
DG8053	C104	CHIP ELECT C	356723319R2	CEWX6.3V-330M	
DG8053	C105	C-CERA C	332161040R1	CK725F1E-104Z1	
DG8053	C106	CHIP ELECT C	356741009R2	CEWX16V-10M	
DG8053	C107	C-CERA C	332161040R1	CK725F1E-104Z1	
DG8053	C108	CHIP ELECT C	356721019R2	CEWX6.3V-100M	
DG8053	C109	C-CERA C	332161040R1	CK725F1E-104Z1	
DG8053	C110	C-CERA C	332104735R1	CK725B1H-473K1	
DG8053	C111	C-CERA C	332161040R1	CK725F1E-104Z1	
DG8053	C112	C-CERA C	332161040R1	CK725F1E-104Z1	
DG8053	C113	C-CERA C	342102214R1	CC725CH1H-221J1	
DG8053	C114	C-CERA C	332121045R1	CK725B1C-104K1	
DG8053	C115	C-CERA C	342104714R1	CC725CH1H-471J1	
DG8053	C117	CHIP ELECT C	356784799R2	CEWX50V-0.47M	
DG8053	C118	C-CERA C	332101035R1	CK725B1H-103K1	
DG8053	C119	C-CERA C	342102214R1	CC725CH1H-221J1	
DG8053	C120	C-CERA C	332101525R1	CK725B1H-152K1	
DG8053	C121	C-CERA C	332104735R1	CK725B1H-473K1	
DG8053	C122	C-CERA C	332161040R1	CK725F1E-104Z1	
DG8053	C123	CHIP ELECT C	356723319R2	CEWX6.3V-330M	
DG8053	C124	C-CERA C	332161040R1	CK725F1E-104Z1	
DG8053	C125	C-CERA C	332161040R1	CK725F1E-104Z1	
DG8053	C126	C-CERA C	332161040R1	CK725F1E-104Z1	
DG8053	C129	CHIP ELECT C	356722219R2	CEWX6.3V-220M	
DG8053	C130	C-CERA C	332161040R1	CK725F1E-104Z1	
DG8053	C131	CHIP ELECT C	356723319R2	CEWX6.3V-330M	
DG8053	C151	C-CERA C	342101504R1	CC725CH1H-150J1	
DG8053	C152	C-CERA C	342101804R1	CC725CH1H-180J1	
DG8053	C157	CHIP ELECT C	356724709R2	CEWX6.3V-47M	
DG8053	C159	CHIP ELECT C	356722219R2	CEWX6.3V-220M	
DG8053	C164	C-CERA C	332161040R1	CK725F1E-104Z1	
DG8053	C170	C-CERA C	332161040R1	CK725F1E-104Z1	
DG8053	C172	C-CERA C	332172240R1	CK725F1C-224Z1	
DG8053	C201	C-CERA C	332103335R1	CK725B1H-333K1	
DG8053	C202	C-CERA C	332103335R1	CK725B1H-333K1	
DG8053	C203	C-CERA C	332101035R1	CK725B1H-103K1	
DG8053	C204	C-CERA C	332101225R1	CK725B1H-122K1	
DG8053	C205	C-CERA C	332101225R1	CK725B1H-122K1	
DG8053	C206	C-CERA C	342106814R1	CC725CH1H-681J1	
DG8053	C207	C-CERA C	342106814R1	CC725CH1H-681J1	
DG8053	C210	CHIP ELECT C	356723319R2	CEWX6.3V-330M	
DG8053	C501	C-CERA C	332161040R1	CK725F1E-104Z1	
DG8053	C502	CHIP ELECT C	356722219R2	CEWX6.3V-220M	
DG8053	C503	C-CERA C	332161040R1	CK725F1E-104Z1	
DG8053	C504	C-CERA C	342103304R1	CC725CH1H-330J1	
DG8053	C505	C-CERA C	332181050R1	CK725F1A-105Z1	
DG8053	C506	C-CERA C	332161040R1	CK725F1E-104Z1	
DG8053	C507	C-CERA C	332161040R1	CK725F1E-104Z1	
DG8053	C508	C-CERA C	332161040R1	CK725F1E-104Z1	
DG8053	C509	C-CERA C	332161040R1	CK725F1E-104Z1	
DG8053	C510	C-CERA C	332161040R1	CK725F1E-104Z1	
DG8053	C511	C-CERA C	332161040R1	CK725F1E-104Z1	
DG8053	C512	C-CERA C	332104735R1	CK725B1H-473K1	
DG8053	C513	CHIP ELECT C	356722219R2	CEWX6.3V-220M	
DG8053	C514	C-CERA C	332161040R1	CK725F1E-104Z1	
DG8053	C551	C-CERA C	332104735R1	CK725B1H-473K1	
DG8053	C552	C-CERA C	332161040R1	CK725F1E-104Z1	
DG8053	C701	C-CERA C	332161040R1	CK725F1E-104Z1	
DG8053	C702	CHIP ELECT C	356741009R2	CEWX16V-10M	
DG8053	C703	C-CERA C	332161040R1	CK725F1E-104Z1	
DG8053	C704	C-CERA C	332161040R1	CK725F1E-104Z1	

DG8053	C705	C-CERA C	332161040R1	CK725F1E-104Z1	
DG8053	C707	C-CERA C	332161040R1	CK725F1E-104Z1	
DG8053	C709	C-CERA C	332161040R1	CK725F1E-104Z1	
DG8053	C710	CHIP ELECT C	356780229R2	CEWX50V-2.2M	
DG8053	C711	C-CERA C	342103304R1	CC725CH1H-330J1	
DG8053	C713	C-CERA C	332161040R1	CK725F1E-104Z1	
DG8053	C714	C-CERA C	332161040R1	CK725F1E-104Z1	
DG8053	C715	C-CERA C	332161040R1	CK725F1E-104Z1	
DG8053	D101	C-DIODE	223269R2	1SS355	
DG8053	D101 or	C-DIODE	223234R2	1SS352	
DG8053	D701	C-DIODE	223269R2	1SS355	
DG8053	D701 or	C-DIODE	223234R2	1SS352	
DG8053	D703	C-DIODE	223269R2	1SS355	
DG8053	D703 or	C-DIODE	223234R2	1SS352	
DG8053	D704	ZENER D	224550560R2	UDZS5.6B	
DG8053	L101	CHOKE COIL	231237K100R2	NCH-1475	
DG8053	L102	CHOKE COIL	230921R2	BLM21B222SPT	
DG8053	L103	CHOKE COIL	230921R2	BLM21B222SPT	
DG8053	L104	CHOKE COIL	230921R2	BLM21B222SPT	
DG8053	L151	CHOKE COIL	230921R2	BLM21B222SPT	
DG8053	L154	CHOKE COIL	230921R2	BLM21B222SPT	
DG8053	L155	CHOKE COIL	230921R2	BLM21B222SPT	
DG8053	L156	CHOKE COIL	230947R2	BLM21B221SB	
DG8053	L157	MPX COIL	232136	NSRF-2046	
DG8053	L158	CHOKE COIL	230921R2	BLM21B222SPT	
DG8053	L202	CHOKE COIL	230921R2	BLM21B222SPT	
DG8053	L501	CHOKE COIL	230921R2	BLM21B222SPT	
DG8053	L502	CHOKE COIL	230921R2	BLM21B222SPT	
DG8053	L503	CHOKE COIL	230921R2	BLM21B222SPT	
DG8053	P101A	SOCKET	25052483	NSCT-16P2380	
DG8053	P102A	PLUG	25055367	NPLG-3P350	
DG8053	P103A	PLUG	25055369	NPLG-5P352	
DG8053	P201A	PLUG	25055979R2	NPLG-6P932	
DG8053	P701A	SOCKET	25052354	NSCT-17P2251	
DG8053	P701A or	SOCKET	25052538	NSCT-17P2435	
DG8053	P904A	PLUG	25055996	NPLG-10P948	
DG8053	Q101	TR	2214373R2	2SA1162-O	
DG8053	Q102	IC	22241585R2	CXA2581N	
DG8053	Q103	IC	22241588R3	CXD3068Q	
DG8053	Q151	IC	22240935R2	TC7WU04FU	
DG8053	Q152	IC	22241965R2	WM8726	
DG8053	Q153	IC	22274000GR2TO	TC74VHCT00AFT	
DG8053	Q154	IC(REGULATOR)	22278005FR2	MPC29L05T	
DG8053	Q155	IC	22274004HR2TO	TC74VHCU04FT	
DG8053	Q201	IC	22241696R2	BA5984FP	
DG8053	Q501	IC	3132-0930-0	LC78683E	
DG8053	Q502	IC	22241909R2	IC41LV16100-50T	
DG8053	Q551	IC	3132-0910-0	AK4103VF	
DG8053	Q701	IC	3132-0950-0	MPD784225GC-237-8BT	
DG8053	Q702	TR	2216250R2	DTC114EKA	
DG8053	Q702 or	TR	2214470R2	RN1402	
DG8053	Q702 or	TR	2216210R2	KRC104S	
DG8053	Q703	IC	22274008GR2TO	TC74VHCT08AFT	
DG8053	Q704	IC	22274032GR2TO	TC74VHCT32AFT	
DG8053	Q705	IC	22274032GR2TO	TC74VHCT32AFT	
DG8053	Q706	IC	3132-0920-0	BR93L56F-WE2	
DG8053	Q709	TR	2216240R2	DTA124EKA	
DG8053	Q709 or	TR	2214540R2	RN2403	
DG8053	Q709 or	TR	2216230R2	KRA103S	
DG8053	R101	C-CARBON R	435031034R1	RN72K1J-103JE	
DG8053	R102	C-CARBON R	435031034R1	RN72K1J-103JE	
DG8053	R103	C-CARBON R	435031014R1	RN72K1J-101JE	
DG8053	R104	C-CARBON R	435034704R1	RN72K1J-470JE	
DG8053	R105	C-CARBON R	435034704R1	RN72K1J-470JE	
DG8053	R107	C-CARBON R	435031044R1	RN72K1J-104JE	
DG8053	R108	C-CARBON R	435031034R1	RN72K1J-103JE	
DG8053	R109	C-CARBON R	435031034R1	RN72K1J-103JE	

DG8053	R110	C-CARBON R	435031544R1	RN72K1J-154JE	
DG8053	R111	C-CARBON R	435036824R1	RN72K1J-682JE	
DG8053	R112	C-CARBON R	435031534R1	RN72K1J-153JE	
DG8053	R113	C-CARBON R	435031034R1	RN72K1J-103JE	
DG8053	R114	C-CARBON R	435031034R1	RN72K1J-103JE	
DG8053	R115	C-CARBON R	435031834R1	RN72K1J-183JE	
DG8053	R116	C-CARBON R	435035624R1	RN72K1J-562JE	
DG8053	R117	C-CARBON R	435033934R1	RN72K1J-393JE	
DG8053	R118	C-CARBON R	435035124R1	RN72K1J-512JE	
DG8053	R119	C-CARBON R	435038224R1	RN72K1J-822JE	
DG8053	R120	C-CARBON R	435033324R1	RN72K1J-332JE	
DG8053	R121	C-CARBON R	435033314R1	RN72K1J-331JE	
DG8053	R122	C-CARBON R	435032224R1	RN72K1J-222JE	
DG8053	R123	C-CARBON R	435030004R1	RN72K1J-000JE	
DG8053	R124	C-CARBON R	435034714R1	RN72K1J-471JE	
DG8053	R125	C-CARBON R	435032224R1	RN72K1J-222JE	
DG8053	R126	C-CARBON R	435032224R1	RN72K1J-222JE	
DG8053	R127	C-CARBON R	435032224R1	RN72K1J-222JE	
DG8053	R128	C-CARBON R	435033314R1	RN72K1J-331JE	
DG8053	R129	C-CARBON R	435031524R1	RN72K1J-152JE	
DG8053	R130	C-CARBON R	435033314R1	RN72K1J-331JE	
DG8053	R131	C-CARBON R	435033314R1	RN72K1J-331JE	
DG8053	R132	C-CARBON R	435033324R1	RN72K1J-332JE	
DG8053	R133	C-CARBON R	435033934R1	RN72K1J-393JE	
DG8053	R134	C-CARBON R	435031244R1	RN72K1J-124JE	
DG8053	R135	C-CARBON R	435033934R1	RN72K1J-393JE	
DG8053	R136	C-CARBON R	435031054R1	RN72K1J-105JE	
DG8053	R137	C-CARBON R	435033334R1	RN72K1J-333JE	
DG8053	R138	C-CARBON R	435031034R1	RN72K1J-103JE	
DG8053	R139	C-CARBON R	435031044R1	RN72K1J-104JE	
DG8053	R140	C-CARBON R	435031054R1	RN72K1J-105JE	
DG8053	R141	C-CARBON R	435031034R1	RN72K1J-103JE	
DG8053	R142	C-CARBON R	435033324R1	RN72K1J-332JE	
DG8053	R143	C-CARBON R	435033324R1	RN72K1J-332JE	
DG8053	R144	C-CARBON R	435034744R1	RN72K1J-474JE	
DG8053	R145	C-CARBON R	435031054R1	RN72K1J-105JE	
DG8053	R146	C-CARBON R	435033314R1	RN72K1J-331JE	
DG8053	R147	C-CARBON R	435031014R1	RN72K1J-101JE	
DG8053	R149	C-CARBON R	435030104R1	RN72K1J-010JE	
DG8053	R150	C-CARBON R	435030004R1	RN72K1J-000JE	
DG8053	R151	C-CARBON R	435032214R1	RN72K1J-221JE	
DG8053	R152	C-CARBON R	435031054R1	RN72K1J-105JE	
DG8053	R153	C-CARBON R	435032224R1	RN72K1J-222JE	
DG8053	R154	C-CARBON R	435032224R1	RN72K1J-222JE	
DG8053	R155	C-CARBON R	435031024R1	RN72K1J-102JE	
DG8053	R156	C-CARBON R	435031024R1	RN72K1J-102JE	
DG8053	R158	C-CARBON R	435034714R1	RN72K1J-471JE	
DG8053	R159	C-CARBON R	435030004R1	RN72K1J-000JE	
DG8053	R160	C-CARBON R	435031044R1	RN72K1J-104JE	
DG8053	R161	C-CARBON R	435037504R1	RN72K1J-750JE	
DG8053	R164	C-CARBON R	435031804R1	RN72K1J-180JE	
DG8053	R165	C-CARBON R	435030104R1	RN72K1J-010JE	
DG8053	R201	C-CARBON R	435031034R1	RN72K1J-103JE	
DG8053	R202	C-CARBON R	435034734R1	RN72K1J-473JE	
DG8053	R203	C-CARBON R	435034734R1	RN72K1J-473JE	
DG8053	R204	C-CARBON R	435031044R1	RN72K1J-104JE	
DG8053	R205	C-CARBON R	435031034R1	RN72K1J-103JE	
DG8053	R206	C-CARBON R	435034734R1	RN72K1J-473JE	
DG8053	R207	C-CARBON R	435034734R1	RN72K1J-473JE	
DG8053	R208	C-CARBON R	435034734R1	RN72K1J-473JE	
DG8053	R209	C-CARBON R	435031834R1	RN72K1J-183JE	
DG8053	R210	C-CARBON R	435031834R1	RN72K1J-183JE	
DG8053	R211	C-CARBON R	435036834R1	RN72K1J-683JE	
DG8053	R212	C-CARBON R	435036834R1	RN72K1J-683JE	
DG8053	R213	C-CARBON R	435038224R1	RN72K1J-822JE	
DG8053	R214	C-CARBON R	435038224R1	RN72K1J-822JE	
DG8053	R501	C-CARBON R	435034714R1	RN72K1J-471JE	



DG8053	R710	C-CARBON R	435036814R1	RN72K1J-681JE	
DG8053	R711	C-CARBON R	435034714R1	RN72K1J-471JE	
DG8053	R712	C-CARBON R	435031024R1	RN72K1J-102JE	
DG8053	R713	C-CARBON R	435031024R1	RN72K1J-102JE	
DG8053	R714	C-CARBON R	435031224R1	RN72K1J-122JE	
DG8053	R715	C-CARBON R	435034714R1	RN72K1J-471JE	
DG8053	R716	C-CARBON R	435032234R1	RN72K1J-223JE	
DG8053	R717	C-CARBON R	435030004R1	RN72K1J-000JE	
DG8053	R718	C-CARBON R	435030004R1	RN72K1J-000JE	
DG8053	R719	C-CARBON R	435030004R1	RN72K1J-000JE	
DG8053	R721	C-CARBON R	435031034R1	RN72K1J-103JE	
DG8053	R722	C-CARBON R	435030004R1	RN72K1J-000JE <MDD>	
DG8053	R723	C-CARBON R	435031034R1	RN72K1J-103JE	
DG8053	R724	C-CARBON R	435034744R1	RN72K1J-474JE	
DG8053	R725	C-CARBON R	435030004R1	RN72K1J-000JE	
DG8053	R726	C-CARBON R	435034714R1	RN72K1J-471JE	
DG8053	R727	C-CARBON R	435034714R1	RN72K1J-471JE	
DG8053	R728	C-CARBON R	435034714R1	RN72K1J-471JE	
DG8053	R729	C-CARBON R	435034714R1	RN72K1J-471JE	
DG8053	R730	C-CARBON R	435034714R1	RN72K1J-471JE	
DG8053	R731	C-CARBON R	435034714R1	RN72K1J-471JE	
DG8053	R732	C-CARBON R	435031224R1	RN72K1J-122JE	
DG8053	R733	C-CARBON R	435034714R1	RN72K1J-471JE	
DG8053	R734	C-CARBON R	435034714R1	RN72K1J-471JE	
DG8053	R735	C-CARBON R	435034714R1	RN72K1J-471JE	
DG8053	R736	C-CARBON R	435034714R1	RN72K1J-471JE	
DG8053	R737	C-CARBON R	435034714R1	RN72K1J-471JE	
DG8053	R738	C-CARBON R	435034714R1	RN72K1J-471JE	
DG8053	R739	C-CARBON R	435034714R1	RN72K1J-471JE	
DG8053	R740	C-CARBON R	435034714R1	RN72K1J-471JE	
DG8053	R741	C-CARBON R	435034714R1	RN72K1J-471JE	
DG8053	R742	C-CARBON R	435034714R1	RN72K1J-471JE	
DG8053	R743	C-CARBON R	435031224R1	RN72K1J-122JE	
DG8053	R744	C-CARBON R	435031224R1	RN72K1J-122JE	
DG8053	R745	C-CARBON R	435030004R1	RN72K1J-000JE	
DG8053	R746	C-CARBON R	435031034R1	RN72K1J-103JE	
DG8053	R747	C-CARBON R	435031024R1	RN72K1J-102JE	
DG8053	R748	C-CARBON R	435033314R1	RN72K1J-331JE	
DG8053	R749	C-CARBON R	435034734R1	RN72K1J-473JE	
DG8053	R750	C-CARBON R	435034734R1	RN72K1J-473JE	
DG8053	R751	C-CARBON R	435034734R1	RN72K1J-473JE	
DG8053	R752	C-CARBON R	435032224R1	RN72K1J-222JE	
DG8053	R753	C-CARBON R	435031224R1	RN72K1J-122JE	
DG8053	R754	C-CARBON R	435030004R1	RN72K1J-000JE	
DG8053	R755	C-CARBON R	435030004R1	RN72K1J-000JE	
DG8053	R756	C-CARBON R	435030004R1	RN72K1J-000JE	
DG8053	R757	C-CARBON R	435030004R1	RN72K1J-000JE	
DG8053	R758	C-CARBON R	435030004R1	RN72K1J-000JE	
DG8053	R759	C-CARBON R	435030004R1	RN72K1J-000JE	
DG8053	R760	C-CARBON R	435030004R1	RN72K1J-000JE	
DG8053	R762	C-CARBON R	435030004R1	RN72K1J-000JE	
DG8053	R763	C-CARBON R	435030004R1	RN72K1J-000JE	
DG8053	R764	C-CARBON R	435031034R1	RN72K1J-103JE	
DG8053	R765	C-CARBON R	435030004R1	RN72K1J-000JE	
DG8053	R766	C-CARBON R	435034734R1	RN72K1J-473JE	
DG8053	R767	C-CARBON R	435034734R1	RN72K1J-473JE	
DG8053	R768	C-CARBON R	435034734R1	RN72K1J-473JE	
DG8053	R769	C-CARBON R	435033324R1	RN72K1J-332JE	
DG8053	X151	CRYSTAL	2300-2340-0	HC-49/U03C16.9344MHZ	
DG8053	X701	CERA LOCK	3010361R2	CSTCE12M5G52-R0	

**U20 : DISPLAY CIRCUIT PC BOARD NADIS-8054**

	CIRCUIT NO.	PART NAME	PART NO.	DESCRIPTION	REMARK
	DIS-8054	C801	ELECT C	394821017	CE04W6.3V100M(SSK)
	DIS-8054	C802	C-CERA C	332161040R1	CK725F1E-104Z1
	DIS-8054	C804	ELECT C	394841007	CE04W16V10M(SSK)
	DIS-8054	C806	C-CERA C	332161040R1	CK725F1E-104Z1

DIS-8054	C807	C-CERA C	332152230R1	CK725F1H-223Z1	
DIS-8054	C808	ELECT C	394880227	CE04W50V2.2M(SSK)	
DIS-8054	C809	C-CERA C	332161040R1	CK725F1E-104Z1	
DIS-8054	C810	C-CERA C	332152230R1	CK725F1H-223Z1	
DIS-8054	C811	C-CERA C	332152230R1	CK725F1H-223Z1	
DIS-8054	C812	C-CERA C	342103304R1	CC725CH1H-330J1	
DIS-8054	C813	C-CERA C	342103304R1	CC725CH1H-330J1	
DIS-8054	C814	C-CERA C	342101014R1	CC725CH1H-101J1	
DIS-8054	C815	C-CERA C	342101014R1	CC725CH1H-101J1	
DIS-8054	C816	C-CERA C	342101014R1	CC725CH1H-101J1	
DIS-8054	D804	ZENER D	224551100R2	UDZS11B	
DIS-8054	P801A	SOCKET AS	7012-6664-0	NSAS-6P1231	
DIS-8054	Q801	IC	22241989R3	MPD780232GC-091-8BT	
DIS-8054	Q802	FL TUBE	2460-2070-0	HNV-12SM57	
DIS-8054	Q802A	HOLDER	4154-7161-0	(FL)	
DIS-8054	Q803	TR	2214394R2	2SC2859-Y	
DIS-8054	Q804	TR	2214394R2	2SC2859-Y	
DIS-8054	Q805	TR	2214530R2	RN2402	
DIS-8054	Q806	TR	2214530R2	RN2402	
DIS-8054	Q807	TR	2214530R2	RN2402	
DIS-8054	Q808	TR	2216470R2	DTC114YKA	
DIS-8054	Q808 or	TR	2216260R2	RN1407	
DIS-8054	Q808 or	TR	2216340R2	KRC107S	
DIS-8054	Q809	TR	2216470R2	DTC114YKA	
DIS-8054	Q809 or	TR	2216260R2	RN1407	
DIS-8054	Q809 or	TR	2216340R2	KRC107S	
DIS-8054	Q810	REMO SENS	241351	SPS-440-1-VP	
DIS-8054	Q811	TR	2216470R2	DTC114YKA	
DIS-8054	Q811 or	TR	2216260R2	RN1407	
DIS-8054	Q811 or	TR	2216340R2	KRC107S	
DIS-8054	R801	C-CARBON R	435031034R1	RN72K1J-103JE	
DIS-8054	R802	C-CARBON R	435033314R1	RN72K1J-331JE	
DIS-8054	R803	C-CARBON R	435033314R1	RN72K1J-331JE	
DIS-8054	R804	C-CARBON R	435034714R1	RN72K1J-471JE	
DIS-8054	R805	C-CARBON R	435036814R1	RN72K1J-681JE <MDD>	
DIS-8054	R805	C-CARBON R	435036814R1	RN72K1J-681JE <MPA,MPP>	
DIS-8054	R806	C-CARBON R	435035604R1	RN72K1J-560JE	
DIS-8054	R807	C-CARBON R	435032724R1	RN72K1J-272JE	
DIS-8054	R808	C-CARBON R	435033914R1	RN72K1J-391JE	
DIS-8054	R809	C-CARBON R	435034714R1	RN72K1J-471JE	
DIS-8054	R810	C-CARBON R	435038214R1	RN72K1J-821JE	
DIS-8054	R811	C-CARBON R	435031024R1	RN72K1J-102JE	
DIS-8054	R812	C-CARBON R	435031824R1	RN72K1J-182JE	
DIS-8054	R813	C-CARBON R	435033914R1	RN72K1J-391JE	
DIS-8054	R814	C-CARBON R	435034714R1	RN72K1J-471JE	
DIS-8054	R815	C-CARBON R	435038214R1	RN72K1J-821JE	
DIS-8054	R816	C-CARBON R	435031024R1	RN72K1J-102JE	
DIS-8054	R817	C-CARBON R	435031824R1	RN72K1J-182JE	
DIS-8054	R818	C-CARBON R	435033924R1	RN72K1J-392JE	
DIS-8054	R819	C-CARBON R	435033924R1	RN72K1J-392JE	
DIS-8054	R826	C-CARBON R	435032724R1	RN72K1J-272JE	
DIS-8054	R827	C-CARBON R	435032724R1	RN72K1J-272JE	
DIS-8054	R828	C-CARBON R	435032724R1	RN72K1J-272JE	
DIS-8054	R829	C-CARBON R	435034714R1	RN72K1J-471JE	
DIS-8054	R830	C-CARBON R	435034714R1	RN72K1J-471JE	
DIS-8054	R831	C-CARBON R	435032234R1	RN72K1J-223JE	
DIS-8054	R832	C-CARBON R	435032234R1	RN72K1J-223JE	
DIS-8054	R834	C-CARBON R	435031014R1	RN72K1J-101JE	
DIS-8054	R835	C-CARBON R	435031014R1	RN72K1J-101JE	
DIS-8054	R836	C-CARBON R	435031044R1	RN72K1J-104JE	
DIS-8054	R837	C-CARBON R	435030004R1	RN72K1J-000JE	
DIS-8054	R888	C-CARBON R	435031044R1	RN72K1J-104JE	
DIS-8054	R889	C-CARBON R	435031044R1	RN72K1J-104JE	
DIS-8054	R890	C-CARBON R	435031044R1	RN72K1J-104JE	
DIS-8054	R891	C-CARBON R	435031044R1	RN72K1J-104JE	
DIS-8054	R892	C-CARBON R	435031044R1	RN72K1J-104JE	
DIS-8054	R893	C-CARBON R	435031044R1	RN72K1J-104JE	

DIS-8054	R894	C-CARBON R	435031044R1	RN72K1J-104JE	
DIS-8054	R895	C-CARBON R	435031044R1	RN72K1J-104JE	
DIS-8054	R896	C-CARBON R	435031044R1	RN72K1J-104JE	
DIS-8054	R897	C-CARBON R	435031044R1	RN72K1J-104JE	
DIS-8054	R898	C-CARBON R	435031044R1	RN72K1J-104JE	
DIS-8054	R899	C-CARBON R	435030004R1	RN72K1J-000JE	
DIS-8054	S806	PUSH SW	25035718	NPS-111-S681	
DIS-8054	S807	PUSH SW	25035718	NPS-111-S681	
DIS-8054	S808	PUSH SW	25035718	NPS-111-S681	
DIS-8054	S809	PUSH SW	25035718	NPS-111-S681	
DIS-8054	S810	PUSH SW	25035718	NPS-111-S681	
DIS-8054	S811	PUSH SW	25035718	NPS-111-S681	
DIS-8054	S812	PUSH SW	25035718	NPS-111-S681	
DIS-8054	S813	PUSH SW	25035718	NPS-111-S681	
DIS-8054	S814	PUSH SW	25035718	NPS-111-S681	
DIS-8054	S815	PUSH SW	25035718	NPS-111-S681	
DIS-8054	S816	PUSH SW	25035718	NPS-111-S681	
DIS-8054	S817	PUSH SW	25035718	NPS-111-S681	
DIS-8054	S818	PUSH SW	25035718	NPS-111-S681	
DIS-8054	S819	PUSH SW	25035718	NPS-111-S681	
DIS-8054	X801	CERA LOCK	3010343	CSTS0500MG06	



**U21 : STANDBY LED PC BOARD NASW-8055**

	CIRCUIT NO.	PART NAME	PART NO.	DESCRIPTION	REMARK
SW-8055	D801	LED	225321	SLR-342VR	
SW-8055	P801B	PLUG	25055989	NPLG-3P941	
SW-8055	R822	C-CARBON R	435033914R1	RN72K1J-391JE	
SW-8055	R823	C-CARBON R	435034714R1	RN72K1J-471JE	
SW-8055	R824	C-CARBON R	435038214R1	RN72K1J-821JE	
SW-8055	R825	C-CARBON R	435031024R1	RN72K1J-102JE	
SW-8055	S801	PUSH SW	25035718	NPS-111-S681	
SW-8055	S802	PUSH SW	25035718	NPS-111-S681	
SW-8055	S803	PUSH SW	25035718	NPS-111-S681	
SW-8055	S804	PUSH SW	25035718	NPS-111-S681	
SW-8055	S805	PUSH SW	25035718	NPS-111-S681	

**U22 : OUTPUT TERMINAL PC BOARD NAAR-8056**

	CIRCUIT NO.	PART NAME	PART NO.	DESCRIPTION	REMARK
AR-8056	C165	C-CERA C	332161040R1	CK725F1E-104Z1	
AR-8056	C166	C-CERA C	332161040R1	CK725F1E-104Z1	
AR-8056	C167	C-CERA C	332161040R1	CK725F1E-104Z1	
AR-8056	C168	ELECT C	394741007	CE04W16V10M(SC)	
AR-8056	C174	CERA C	335321025	CK45B50V-102K	
AR-8056	C301	VX C	393362207	CE04W35V-22M(VX)	
AR-8056	C302	VX C	393362207	CE04W35V-22M(VX)	
AR-8056	C303	TF C	374721024	ECQ-B50V-102J	
AR-8056	C304	TF C	374721024	ECQ-B50V-102J	
AR-8056	C305	TF C	374722724	ECQ-B50V-272J	
AR-8056	C306	TF C	374722724	ECQ-B50V-272J	
AR-8056	C307	TF C	374721824	ECQ-B50V-182J	
AR-8056	C308	TF C	374721824	ECQ-B50V-182J	
AR-8056	C309	VX C	393362207	CE04W35V-22M(VX)	
AR-8056	C310	VX C	393362207	CE04W35V-22M(VX)	
AR-8056	C311	ELECT C	394742217	CE04W16V220M(SC)	
AR-8056	C312	ELECT C	394742217	CE04W16V220M(SC)	
AR-8056	C315	C-CERA C	332161040R1	CK725F1E-104Z1	
AR-8056	C904	ELECT C	394641037S	CE04W16V10000M(VR)	
AR-8056	C905	ELECT C	394642227S	CE04W16V2200M(VR)	
AR-8056	C906	ELECT C	394741007	CE04W16V10M(SC)	
AR-8056	C908	ELECT C	394781017	CE04W50V100M(SC)	
AR-8056	C909	C-CERA C	332152230R1	CK725F1H-223Z1	
AR-8056	C910	ELECT C	394764707	CE04W35V47M(SC)	
AR-8056	C911	ELECT C	394741007	CE04W16V10M(SC)	
AR-8056	C913	ELECT C	394741007	CE04W16V10M(SC)	
AR-8056	C915	ELECT C	394742217	CE04W16V220M(SC)	
AR-8056	D301	ZENER D	224490470R2	UDZ4.7B	
AR-8056	D901	DIODE	22380271F	D3SBA20	
AR-8056	D905	DIODE	22380260	RL1N4003	
AR-8056	D905 or	DIODE	22380035	GP104003E	
AR-8056	D906	ZENER D	224553000R2	UDZS30B	
AR-8056	D907	C-DIODE	223269R2	1SS355	
AR-8056	D907 or	C-DIODE	223234R2	1SS352	
AR-8056	D908	C-DIODE	223269R2	1SS355	
AR-8056	D908 or	C-DIODE	223234R2	1SS352	
AR-8056	D909	ZENER D	224550510R2	UDZS5.1B	
AR-8056	E901	HOLDER	27190608-1	(CRAMP) UA-0 V0	
AR-8056	L152	CHOKE COIL	230921R2	BLM21B222SPT	
AR-8056	L153	CHOKE COIL	230921R2	BLM21B222SPT	
AR-8056	L159	CHOKE COIL	230921R2	BLM21B222SPT	
AR-8056	L901	CHOKE COIL	230921R2	BLM21B222SPT	
AR-8056	P102B	PLUG	25055147	NPLG-3P131	
AR-8056	P103B	PLUG	25055149	NPLG-5P133	
AR-8056	P151	PIN JACK	25045628	NPJ-2PDRW435 <MDD>	
AR-8056	P151	PIN JACK	25045628	NPJ-2PDRW435 <MPA,MPP>	
AR-8056	P152	PIN JACK	25045548	NPJ-1PDOR369 <MDD>	
AR-8056	P152	PIN JACK	25045548	NPJ-1PDOR369 <MPA,MPP>	
AR-8056	P153	PIN JACK	25045589	NPJ-2PDB400	
AR-8056	P705B	PLUG	25055151	NPLG-7P135	

AR-8056	P902B	PLUG	25055136	NPLG-6P120	
AR-8056	P904B	PLUG	25055448	NPLG-10P430	
AR-8056	Q156	PHT CP	24120094	TOTX179	
AR-8056	Q301	IC	22241448R2	NJM4580M-D	
AR-8056	Q302	IC	22241448R2	NJM4580M-D	
AR-8056	Q303	IC	22241448R2	NJM4580M-D	
AR-8056	Q305	TR	2211705	2SD655-E	
AR-8056	Q305 or	TR	2211706	2SD655-F	
AR-8056	Q306	TR	2211705	2SD655-E	
AR-8056	Q306 or	TR	2211706	2SD655-F	
AR-8056	Q307	TR	2216240R2	DTA124EKA	
AR-8056	Q307 or	TR	2214540R2	RN2403	
AR-8056	Q307 or	TR	2216230R2	KRA103S	
AR-8056	Q901	IC(REGULATOR)	22278005DNE	MPC2905HF	
AR-8056	Q901A	HEAT SINK	27160472	RAD-141	
AR-8056	Q901B	SCREW	82143010	3P+10FN(BC)	
AR-8056	Q902	TR	2211503	2SA950-O	
AR-8056	Q902 or	TR	2211504	2SA950-Y	
AR-8056	Q903	IC(REGULATOR)	22278033ER2NE	MPC29M33T	
AR-8056	Q904	TR	2214383R2	2SA1182-O	
AR-8056	Q905	TR	2216470R2	DTC114YKA	
AR-8056	Q905 or	TR	2216260R2	RN1407	
AR-8056	Q905 or	TR	2216340R2	KRC107S	
AR-8056	R148	C-CARBON R	435034714R1	RN72K1J-471JE	
AR-8056	R301	C-CARBON R	435031524R1	RN72K1J-152JE	
AR-8056	R302	C-CARBON R	435031524R1	RN72K1J-152JE	
AR-8056	R303	C-CARBON R	435031034R1	RN72K1J-103JE	
AR-8056	R304	C-CARBON R	435031034R1	RN72K1J-103JE	
AR-8056	R305	C-CARBON R	435031034R1	RN72K1J-103JE	
AR-8056	R306	C-CARBON R	435031034R1	RN72K1J-103JE	
AR-8056	R307	C-CARBON R	435031524R1	RN72K1J-152JE	
AR-8056	R308	C-CARBON R	435031524R1	RN72K1J-152JE	
AR-8056	R309	C-CARBON R	435032234R1	RN72K1J-223JE	
AR-8056	R310	C-CARBON R	435032234R1	RN72K1J-223JE	
AR-8056	R311	C-CARBON R	435032234R1	RN72K1J-223JE	
AR-8056	R312	C-CARBON R	435032234R1	RN72K1J-223JE	
AR-8056	R313	C-CARBON R	435032234R1	RN72K1J-223JE	
AR-8056	R314	C-CARBON R	435032234R1	RN72K1J-223JE	
AR-8056	R315	C-CARBON R	435031524R1	RN72K1J-152JE	
AR-8056	R316	C-CARBON R	435031524R1	RN72K1J-152JE	
AR-8056	R317	C-CARBON R	435031524R1	RN72K1J-152JE	
AR-8056	R318	C-CARBON R	435031524R1	RN72K1J-152JE	
AR-8056	R319	C-CARBON R	435032234R1	RN72K1J-223JE	
AR-8056	R320	C-CARBON R	435032234R1	RN72K1J-223JE	
AR-8056	R321	C-CARBON R	435034744R1	RN72K1J-474JE	
AR-8056	R322	C-CARBON R	435034744R1	RN72K1J-474JE	
AR-8056	R323	C-CARBON R	435034714R1	RN72K1J-471JE	
AR-8056	R324	C-CARBON R	435034714R1	RN72K1J-471JE	
AR-8056	R325	C-CARBON R	435031024R1	RN72K1J-102JE	
AR-8056	R326	C-CARBON R	435031024R1	RN72K1J-102JE	
AR-8056	R327	C-CARBON R	435034744R1	RN72K1J-474JE	
AR-8056	R328	C-CARBON R	435034744R1	RN72K1J-474JE	
AR-8056	R329	C-CARBON R	435031024R1	RN72K1J-102JE	
AR-8056	R330	METAL O R	443521214	RS1/2WBJ-120	
AR-8056	R331	METAL O R	443521214	RS1/2WBJ-120	
AR-8056	R332	C-CARBON R	435031024R1	RN72K1J-102JE	
AR-8056	R333	C-CARBON R	435031024R1	RN72K1J-102JE	
AR-8056	R334	C-CARBON R	435031034R1	RN72K1J-103JE	
AR-8056	R335	C-CARBON R	435030004R1	RN72K1J-000JE	
AR-8056	R336	C-CARBON R	435030004R1	RN72K1J-000JE	
AR-8056	R341	C-CARBON R	435034744R1	RN72K1J-474JE	
AR-8056	R342	C-CARBON R	435034744R1	RN72K1J-474JE	
AR-8056	R901	C-CARBON R	435033324R1	RN72K1J-332JE	
AR-8056	R902	C-CARBON R	435033914R1	RN72K1J-391JE	
AR-8056	R903	C-CARBON R	435033914R1	RN72K1J-391JE	
AR-8056	R904	C-CARBON R	435034714R1	RN72K1J-471JE	
AR-8056	R905	C-CARBON R	435033324R1	RN72K1J-332JE	

AR-8056	R907	C-CARBON R	435032234R1	RN72K1J-223JE	
AR-8056	R908	C-CARBON R	435033914R1	RN72K1J-391JE	

**U23 : MECHANISM CONYROL PC BOARD NADG-8057**

	CIRCUIT NO.	PART NAME	PART NO.	DESCRIPTION	REMARK
DG-8057	C601	ELECT C	394841017	CE04W16V100M(SSK)	
DG-8057	C602	C-CERA C	332152230R1	CK725F1H-223Z1	
DG-8057	C605	C-CERA C	332161040R1	CK725F1E-104Z1	
DG-8057	C606	ELECT C	394841017	CE04W16V100M(SSK)	
DG-8057	C607	C-CERA C	332152230R1	CK725F1H-223Z1	
DG-8057	C609	C-CERA C	332152230R1	CK725F1H-223Z1	
DG-8057	C610	C-CERA C	332152230R1	CK725F1H-223Z1	
DG-8057	C611	C-CERA C	332152230R1	CK725F1H-223Z1	
DG-8057	D601	ZENER D	224490220R2	UDZ2.2B	
DG-8057	D602	ZENER D	224490270R2	UDZ2.7B	
DG-8057	D603	ZENER D	224550430R2	UDZS4.3B	
DG-8057	D604	ZENER D	224550470R2	UDZS4.7B	
DG-8057	P701B	SOCKET	25052354	NSCT-17P2251	
DG-8057	P701B or	SOCKET	25052538	NSCT-17P2435	
DG-8057	P702A	SOCKET	25052202	NSCT-6P2099	
DG-8057	P702A or	SOCKET	25051813	NSCT-6P1600	
DG-8057	P702A or	SOCKET	25052015	NSCT-6P1802	
DG-8057	P704B	PLUG	25055988	NPLG-2P940	
DG-8057	P705A	SOCKET AS	7012-6663-0	NSAS-14P1239	
DG-8057	P751A	SOCKET AS	2002E242215UL	NSAS-22P1126	
DG-8057	Q601	IC	22240239	TA7291S	
DG-8057	Q602	IC	22240239	TA7291S	
DG-8057	Q603	TR	2216470R2	DTC114YKA	
DG-8057	Q603 or	TR	2216260R2	RN1407	
DG-8057	Q603 or	TR	2216340R2	KRC107S	
DG-8057	Q604	TR	2216470R2	DTC114YKA	
DG-8057	Q604 or	TR	2216260R2	RN1407	
DG-8057	Q604 or	TR	2216340R2	KRC107S	
DG-8057	Q605	TR	2216470R2	DTC114YKA	
DG-8057	Q605 or	TR	2216260R2	RN1407	
DG-8057	Q605 or	TR	2216340R2	KRC107S	
DG-8057	Q606	TR	2216470R2	DTC114YKA	
DG-8057	Q606 or	TR	2216260R2	RN1407	
DG-8057	Q606 or	TR	2216340R2	KRC107S	
DG-8057	Q607	TR	2216470R2	DTC114YKA	
DG-8057	Q607 or	TR	2216260R2	RN1407	
DG-8057	Q607 or	TR	2216340R2	KRC107S	
DG-8057	Q608	TR	2214373R2	2SA1162-O	
DG-8057	R601	C-CARBON R	435031044R1	RN72K1J-104JE	
DG-8057	R602	C-CARBON R	435031044R1	RN72K1J-104JE	
DG-8057	R603	C-CARBON R	435032224R1	RN72K1J-222JE	
DG-8057	R604	NF CARBON R	415470474	R25J-4.7	
DG-8057	R605	C-CARBON R	435031044R1	RN72K1J-104JE	
DG-8057	R606	C-CARBON R	435031044R1	RN72K1J-104JE	
DG-8057	R607	C-CARBON R	435030004R1	RN72K1J-000JE	
DG-8057	R609	C-CARBON R	435032214R1	RN72K1J-221JE	
DG-8057	R610	C-CARBON R	435032234R1	RN72K1J-223JE	
DG-8057	R611	C-CARBON R	435035624R1	RN72K1J-562JE	
DG-8057	R612	C-CARBON R	435031034R1	RN72K1J-103JE	
DG-8057	R613	NF CARBON R	415470474	R25J-4.7	
DG-8057	R614	C-CARBON R	435031034R1	RN72K1J-103JE	
DG-8057	R615	C-CARBON R	435031034R1	RN72K1J-103JE	
DG-8057	R616	C-CARBON R	435031034R1	RN72K1J-103JE	
DG-8057	R617	C-CARBON R	435031034R1	RN72K1J-103JE	
DG-8057	R618	C-CARBON R	435033324R1	RN72K1J-332JE	
DG-8057	R619	C-CARBON R	435032744R1	RN72K1J-274JE	
DG-8057	R620	C-CARBON R	435031054R1	RN72K1J-105JE	
DG-8057	R621	C-CARBON R	435038224R1	RN72K1J-822JE	
DG-8057	R622	C-CARBON R	435031034R1	RN72K1J-103JE	
DG-8057	R623	C-CARBON R	435035624R1	RN72K1J-562JE	
DG-8057	R624	C-CARBON R	435038224R1	RN72K1J-822JE	
DG-8057	R625	C-CARBON R	435031054R1	RN72K1J-105JE	
DG-8057	R626	C-CARBON R	435034724R1	RN72K1J-472JE	
DG-8057	R627	C-CARBON R	435032224R1	RN72K1J-222JE	

DG-8057	R628	C-CARBON R	435030004R1	RN72K1J-000JE	
DG-8057	S601	PUSH SW	25035716	NPS-111-S679	
DG-8057	S602	PUSH SW	25035716	NPS-111-S679	
DG-8057	S603	PUSH SW	25035716	NPS-111-S679	

**U24 : POWER TRANSFORMER PC BOARD NAPS-8058**

	CIRCUIT NO.	PART NAME	PART NO.	DESCRIPTION	REMARK
PS-8058	C901	IS C	! 3300030	DE1307E472M-KH	
PS-8058	C902	IS C	! 3300030	DE1307E472M-KH	
PS-8058	C903	TF C	374723344	ECQ-V50V-334J	
PS-8058	C912	TF C	374721044	ECQ-V50V-104J	
PS-8058	C916	TF C	374723344	ECQ-V50V-334J	
PS-8058	C917	TF C	374722244	ECQ-V50V-224J	
PS-8058	P802B	PLUG	25055988	NPLG-2P940	
PS-8058	P901A	PLUG	25055676	NPLG-2P632	
PS-8058	P902A	SOCKET AS	7012-6660-0	NSAS-12P1233	
PS-8058	T902	CHOKE COIL	231287	NCH-3567	

**U25 : DISC SENSOR PC BOARD NAETC-8059**

	CIRCUIT NO.	PART NAME	PART NO.	DESCRIPTION	REMARK
ETC-8059	C652	C-CERA C	332161040R1	CK725F1E-104Z1	
ETC-8059	C653	C-CERA C	332152230R1	CK725F1H-223Z1	
ETC-8059	C654	C-CERA C	332152230R1	CK725F1H-223Z1	
ETC-8059	P702B	SOCKET	25052239	NSCT-6P2136	
ETC-8059	P702B or	SOCKET	25052052	NSCT-6P1839	
ETC-8059	P702B or	SOCKET	25051850	NSCT-6P1637	
ETC-8059	P703A	SOCKET AS	2002E390415UL	NSAS-4P1127	
ETC-8059	Q651	PHT INT	24190046	GP2S28	
ETC-8059	Q652	PHT CP	24120107	RPI-576	
ETC-8059	R651	C-CARBON R	435031814R1	RN72K1J-181JE	
ETC-8059	R652	C-CARBON R	435031544R1	RN72K1J-154JE	
ETC-8059	R653	C-CARBON R	435033314R1	RN72K1J-331JE	
ETC-8059	R654	C-CARBON R	435034744R1	RN72K1J-474JE	
ETC-8059	R655	C-CARBON R	435030004R1	RN72K1J-000JE	
ETC-8059	R656	C-CARBON R	435030004R1	RN72K1J-000JE	

**U26 : ROULETTE MOTOR PC BOARD NAETC-8060**

	CIRCUIT NO.	PART NAME	PART NO.	DESCRIPTION	REMARK
ETC-8060	C655	C-CERA C	332161040R1	CK725F1E-104Z1	
ETC-8060	P703B	PLUG	25055440	NPLG-2P422	

**U27 : LOADING MOTOR PC BOARD NAETC-8061**

	CIRCUIT NO.	PART NAME	PART NO.	DESCRIPTION	REMARK
ETC-8061	C656	C-CERA C	332161040R1	CK725F1E-104Z1	
ETC-8061	P704A	SOCKET AS	2002A340420UL	NSAS-4P1138	

**U28 : CONNECTION PC BOARD NAETC-8062**

	CIRCUIT NO.	PART NAME	PART NO.	DESCRIPTION	REMARK
ETC-8062	P752	SOCKET AS	7012-6748-0	NSAS-22P1253	
ETC-8062	P751B	PLUG	25055449	NPLG-11P431	

**U29 : ILLUMINATION PC BOARD NADIS-8066**

	CIRCUIT NO.	PART NAME	PART NO.	DESCRIPTION	REMARK
DIS-8066	D802	LED	3700-2832-B	SELU2L10C	
DIS-8066	D802A	HOLDER	27191190	(LED)LA-5-6	
DIS-8066	D803	LED	3700-2832-B	SELU2L10C	
DIS-8066	D803A	HOLDER	27191190	(LED)LA-5-6	
DIS-8066	P802A	SOCKET AS	7012-6665-0	NSAS-4P1232	
DIS-8066	R820	C-CARBON R	435035604R1	RN72K1J-560JE	
DIS-8066	R821	C-CARBON R	435035604R1	RN72K1J-560JE	

**U30 : POWER SWITCH PC BOARD NASW-8063 <MPP, MPA> ONLY**

	CIRCUIT NO.	PART NAME	PART NO.	DESCRIPTION	REMARK
SW-8063	C907	IS C	3500196S	RE275V-103M <MPP,MPA>	
SW-8063	J901	CRIMP AS	206994318JUL	CRIMP AS <MPP,MPA>	
SW-8063	J902	CRIMP AS	206994318JUL	CRIMP AS <MPP,MPA>	

SW-8063	S901	PUSH SW	25035703	NPS-111-L666P <MPP,MPA>	
SW-8063	S901 or	P SW	25035550	NPS-111-L512P <MPP,MPA>	

**MDD:** North American area

**MPP:** European area

**MPA:** Australian area

---

**ONKYO CORPORATION**

Sales & Product Planning Div. : 2-1, Nisshin-cho, Neyagawa-shi, OSAKA 572-8540, JAPAN  
Tel: 072-831-8023 Fax: 072-831-8124

**ONKYO U.S.A. CORPORATION**

18 Park Way, Upper Saddle River, N.J. 07458, U.S.A.  
Tel: 201-785-2600 Fax: 201-785-2650 <http://www.onkyousa.com>

**ONKYO EUROPE ELECTRONICS GmbH**

Liegnitzerstrasse 6, 82194 Groebenzell, GERMANY  
Tel: +49-8142-4401-0 Fax: +49-8142-4401-555 <http://www.onkyo.net>

**ONKYO CHINA LIMITED**

Units 2102-2107, Metroplaza Tower I, 223 Hing Fong Road, Kwai Chung,  
N.T., HONG KONG Tel: 852-2429-3118 Fax: 852-2428-9039

