

ONKYO® SERVICE MANUAL

COMPACT DISC CHANGER MODEL DX-C540

Black model only

BMD	120V AC, 60Hz
BMP/BMPA/BMPT	230V AC, 50Hz

SAFETY-RELATED COMPONENT WARNING!!

COMPONENTS IDENTIFIED BY MARK \triangle ON THE SCHEMATIC DIAGRAM AND IN THE PARTS LIST ARE CRITICAL FOR RISK OF FIRE AND ELECTRIC SHOCK. REPLACE THESE COMPONENTS WITH ONKYO PARTS WHOSE PART NUMBERS APPEAR AS SHOWN IN THIS MANUAL.

MAKE LEAKAGE-CURRENT OR RESISTANCE MEASUREMENTS TO DETERMINE THAT EXPOSED PARTS ARE ACCEPTABLY INSULATED FROM THE SUPPLY CIRCUIT BEFORE RETURNING THE APPLIANCE TO THE CUSTOMER.

SPECIFICATIONS

Signal readout system;	Optical non-contact
Reading rotation;	About 500 - 200 r.p.m. (constant linear velocity)
Linear velocity;	1.2 - 1.4 m/s
Error correction system;	Cross Interleave Reed-Solomon code
D/A converter:	1 bit PWM / ACCUPULSE
Sampling frequency:	352.8 kHz (8 times oversampling)
Number of channels:	2 (stereo)
Frequency response:	5 Hz - 20 kHz
Total harmonic distortion:	0.005 % (at 1 kHz)
Dynamic range:	96 dB
Signal to noise ratio:	92 dB
Channel separation:	92 dB (at 1 kHz)
Wow and Flutter:	Below threshold of measurability
Output level:	2 volts r.m.s.
Power consumption:	11 watts
Power supply:	120 V, 60 Hz 230 V, 50 Hz
Dimensions (W × H × D):	435 × 131 × 433 mm (17-1/8" × 5-3/16" × 17-1/16")
Weight:	6.9 kg, (15.2 lbs.)

Specifications and features are subject to change without notice .



TABLE OF CONTENTS

Specifications	1
Caution on replacement of optical pick-up	2
Protection of eyes from laser beam during servicing	3
Laser warning label	3
IC block diagram and descriptions	4
Microprocessor connection diagram	8
Microprocessor terminal description	9
Care should be taken with the optical pickup	10
Adjustment procedures	11
Pick-up drive unit/part list	12
Trouble shooting	13
Initializing operation	15
Error message displayed in heat-running mode	16
Chassis exploded view parts list	17
Changer mechanism parts list	18
Chassis exploded view	19
Block diagram	21
Schematic diagram	23
Printed circuit board view from bottom side	25
Printed circuit board-parts list	29
Packing view/parts list	31

CAUTION ON REPLACEMENT OF OPTICAL PICK UP

The laser diode in the optical pickup block is so sensitive to static electricity, surge current and etc, that the components are liable to be broken down or its reliability remarkably deteriorated.

During repair, carefully take the following precautions. (The following precautions are included in the service parts.)

PRECAUTIONS

1. Ground for the work-desk.

Place a conductive sheet such as a sheet of copper (with impedance lower than $10M\Omega$) on the work-desk and place the set on the conductive sheet so that the chassis.

2. Grounding for the test equipment and tools.

Test equipments and toolings should be grounded in order that their ground level is the same the ground of the power source.

3. Grounding for the human body.

Be sure to put on a wrist-strap for grounding whose other end is grounded.

Be particularly careful when the workers wear synthetic fiber clothes, or air is dry.

4. Select a soldering iron that permits no leakage and have the tip of the iron well-grounded.

5. Do not check the laser diode terminals with the probe of a circuit tester or oscilloscope.

PROTECTION OF EYES FROM LASER BEAM DURING SERVICING

This set employs a laser. Therefore, be sure to follow carefully the instructions below when servicing.

WARNING !!

WHEN SERVICING, DO NOT APPROACH THE LASER EXIT WITH THE EYES TOO CLOSELY. IN CASE IT IS NECESSARY TO CONFIRM LASER BEAM EMISSION, BE SURE TO OBSERVE FROM A DISTANCE OF MORE THAN 30cm FROM THE SURFACE OF THE OBJECTIVE LENS ON THE OPTICAL PICK-UP BLOCK.

Laser Diode Properties

- Material: GaAlAs
- Wavelength: 760-800nm
- Emission Duration: continuous
- Laser output: max. 0.5mW*

* This output is the value measure at a distance about 1.8mm from the objective lens surface on the Optical pick-up Block.

LASER WARNING LABELS

There labels are located on the mechanism.

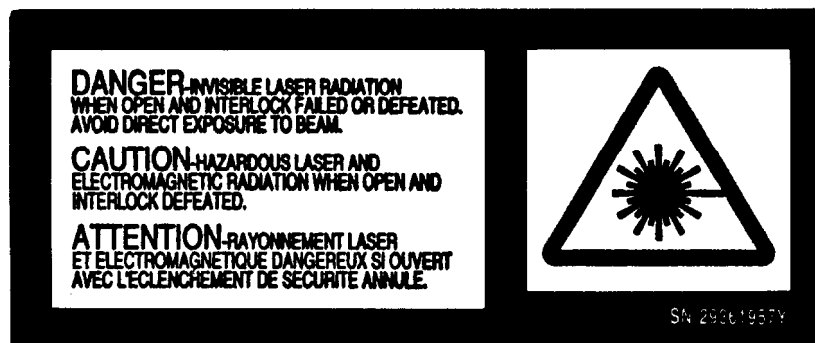
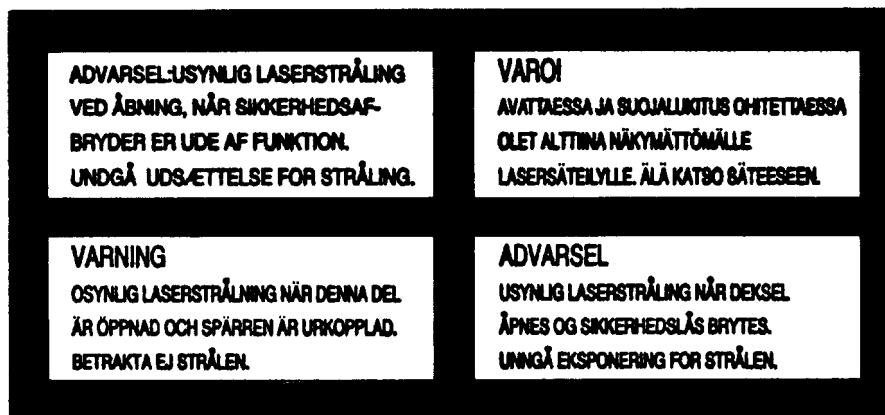

IC BLOCK DIAGRAMS AND DESCRIPTIONS

CXD2507AQ (Digital Signal Processor)

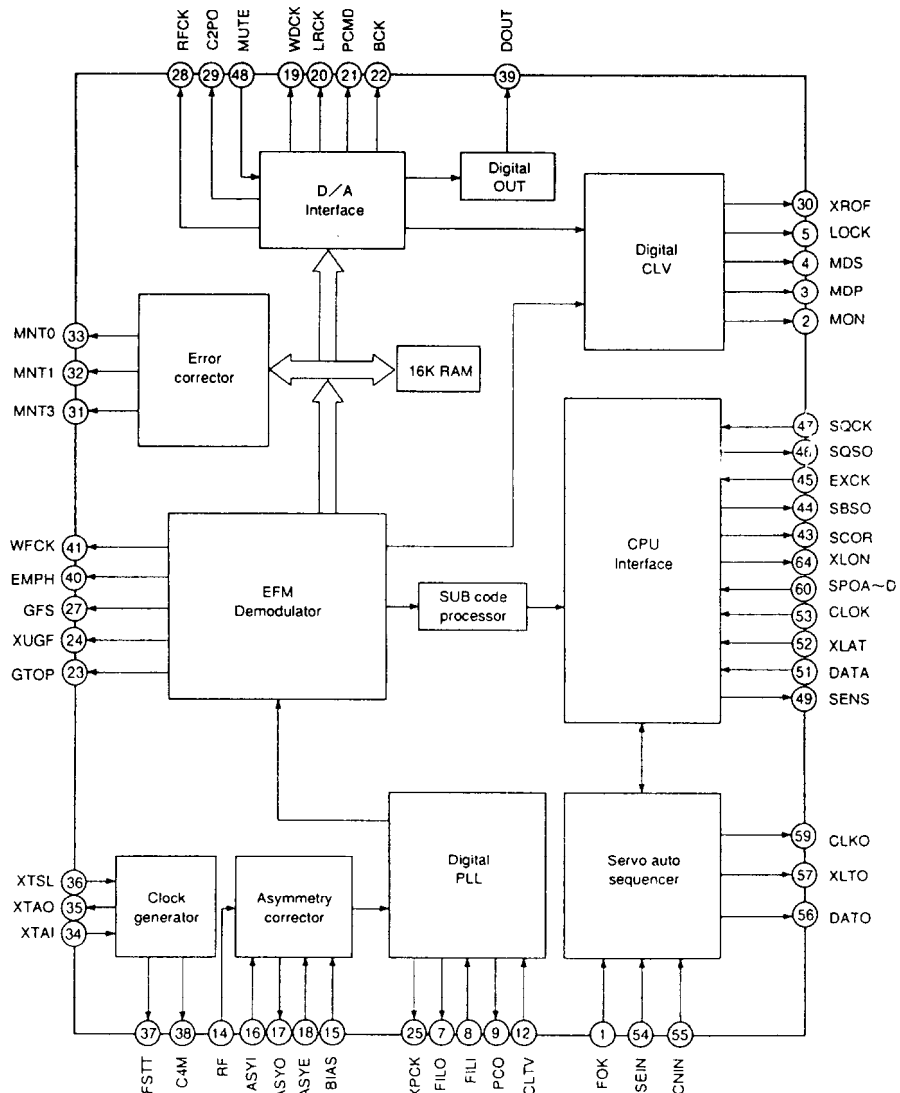

TA-7291S (Motor Drive)

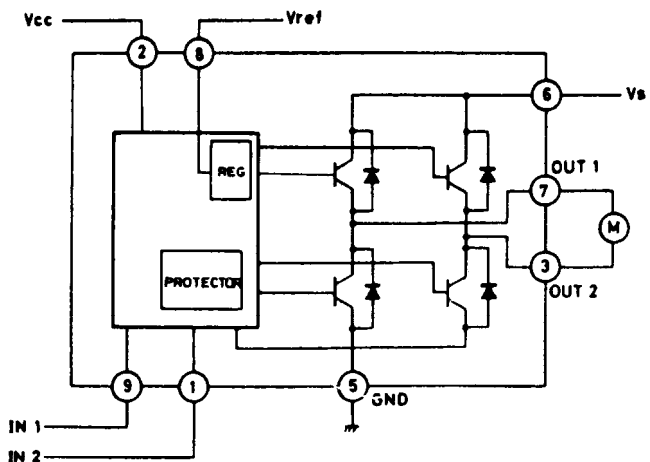

BA6191 (Motor Drive)

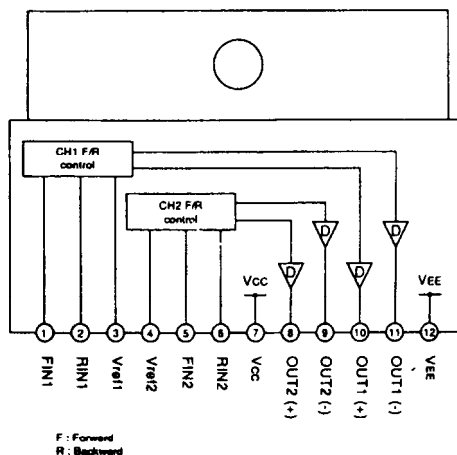

NO.	SYMBOL	I/O	DESCRIPTION
1	FOK	I	Focus OK input
2	MON	O	Spindle motor ON/OFF control output
3	MDP	O	Spindle motor servo control
4	MDS	O	Spindle motor servo control
5	LOCK	O	H when GFS is the high level
6	TEST	I	Test terminal
7	FIL0	O	Filter output for master PLL.
8	FIL1	I	Filter input for master PLL.
9	PCO	O	Charge pump output of master PLL.
10	Vss	-	Ground terminal
11	AVss	-	Analog ground
12	CLTV	I	VCO control voltage input for master
13	AVDD	-	Analog section power supply (+5V)
14	RF	I	EFM signal input
15	BIAS	I	Asymmetry circuit constant current input
16	ASY1	I	Asymmetry comparator voltage input
17	ASY0	O	EFM full swing output. (at L: Vss, H:Vdd)
18	ASYE	I	Asymmetry control circuit. (at L: asymmetry circuit OFF, H: asymmetry circuit ON)
19	WDCK	O	D/A interface for 48 bits slot. Word clock $f=2Fs$.
20	LRCK	O	D/A interface for 48 bits slot. LR clock $f=Fs$.
21	PCMD	O	D/A interface for 48 bits slot. Serial data. (2's COMP, MSB fast)
22	BCK	O	D/A interface for 48 bits slot. Bit clock.
23	GTOP	O	GTOP output
24	XUGF	O	XUGF output
25	XPCK	O	XPLCK output
26	VDD	-	Power supply terminal (+5V)
27	GFS	O	GFS output
28	RFCK	O	RFCK output
29	C2P0	O	C2P0 output
30	XROF	O	XRAOF output
31	MNT3	O	MNT 3 output
32	MNT1	O	MNT 1 output
33	MNT0	O	MNT 0 output
42	Vss	-	Ground terminal
34	XTAI	I	Crystal oscillation circuit input of 16.9344MHz or 33.8688MHz input.
35	XTAO	O	Crystal oscillation circuit output of 16.9344MHz.
36	XTSL	I	Crystal selection input terminal. L when 16.9344MHz. H when 33.8688MHz.
37	FSTT	O	2/3 divided output of pins 34 and 35.
38	C4M	O	4.2336 MHz output
39	DOUT	O	Digital output
40	EMPH	O	Emphasis control output. Active high.
41	WFCK	O	WFCK (Write Frame Clock) output
43	SCOR	O	Sub-code detection output. H when is detected S0 or S1.
44	SBSO	O	Serial output of sub-code (P~W)
45	EXCK	I	Clock input for read out SBSO.
46	SQSO	O	Serial output of sub Q 80 bits.
47	SOCK	I	Clock input for read out SQSO
48	MUTE	I	Muting control input. Active H.
49	SENS	O	Sens output. Output to the microprocessor.
50	XRST	I	System reset. Reset at the low level.
51	DATA	I	Serial data input from the microprocessor.
52	XLAT	I	Latch input from the microprocessor. Latch the serial data at the trailing.
58	VDD	-	Power supply terminal (+5V).
53	CLOK	I	Serial data transfer clock input from microprocessor.
54	SEIN	I	Sens input from SSP.
55	CNIN	I	Track jump numbers count signal input.
56	DATO	O	Serial data output to SSP.
57	XLTO	O	Serial data latch output to SSP. Latch at trailing.
59	CLKO	O	Serial data transfer clock output to SSP.
60	SPOA	I	Microprocessor extend interface (input A)
61	SPOB	I	Microprocessor extend interface (input B)
62	SPOC	I	Microprocessor extend interface (input C)
63	SPOD	I	Microprocessor extend interface (input D)
64	XLON	O	Microprocessor extend interface (output)

CXA1782BQ (Servo Signal Processor)

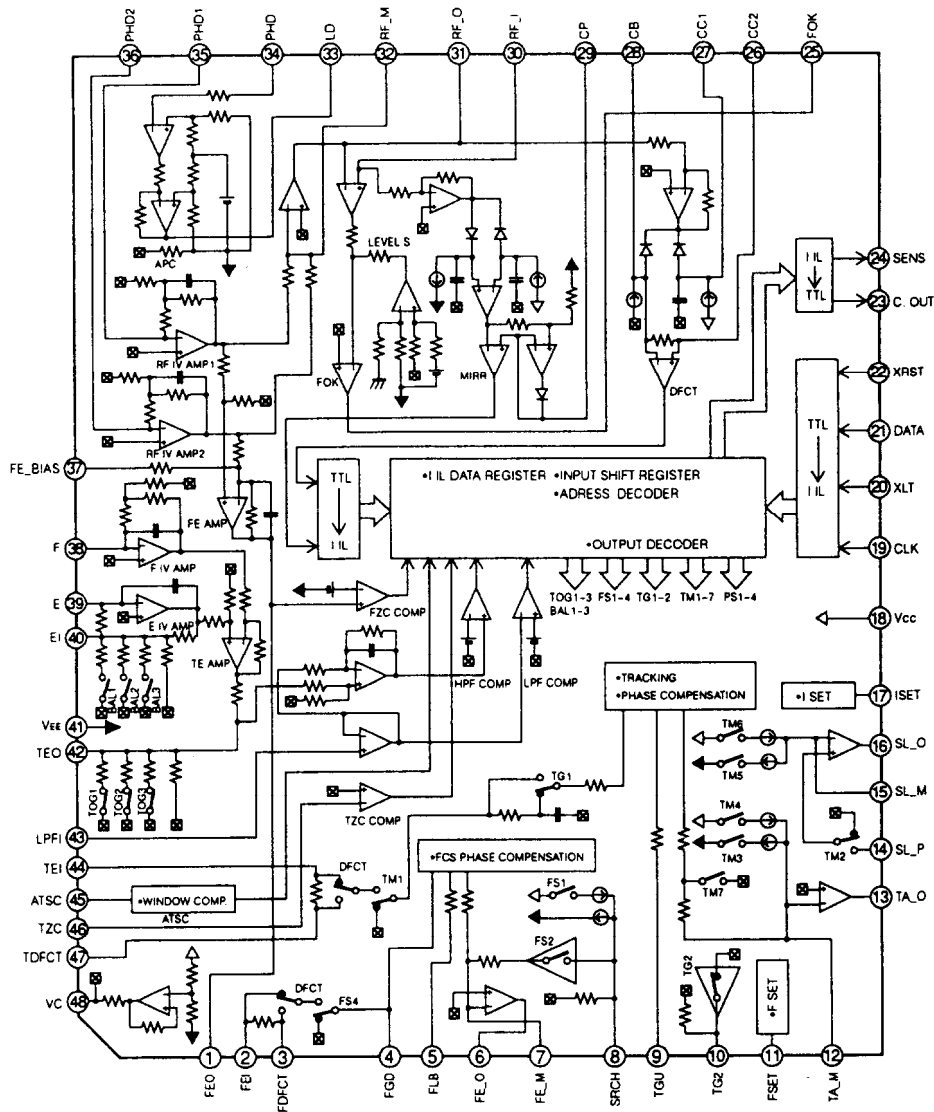

PIN NO.	SYMBOL	I/O	DESCRIPTION	PIN NO.	SYMBOL	I/O	DESCRIPTION
1	FEO	I	Focus error amplifier output terminal.	21	DATA	I	Serial data input terminal for microprocessor.
2	FEI	I	Focus error input terminal.	22	XRST	I	Reset input terminal. Active low.
3	FDFCT	I	Capacitor connection terminal for time constant when defect.	23	C.OUT	O	Signal output to count the track numbers.
4	FGD	I	Connect the capacitor between GND and this pin when the high frequency gain focus servo is dropped.	24	SENS	O	This terminal outputs FZC, DFCT, TZC, Gain and BAL to according command from the microprocessor.
5	FLB	I	Input terminal for the low frequency boost of focus servo.	25	FOK	O	Focus OK comparator output terminal.
6	FE O	O	Focus driver output terminal.	26	CC2	I	Defect bottom hold input terminal from CC1.
7	FE M	I	Inversion input terminal of focus amplifier.	27	CC1	O	Defect bottom hold output terminal.
8	SRCH	I	Time constant terminal to make the focus search waveform.	28	CB	I	Defect bottom hold capacitor connection terminal.
9	TGU	I	Tracking high frequency changeover input terminal.	29	CP	I	Mirror hold capacitor connection terminal.
10	TG2	I	Tracking high frequency changeover input terminal.	30	RF I	I	RF summing amplifier input terminal.
11	FSET	I	Peak setting input of phase correction of focus tracking.	31	RF O	O	RF summing amplifier output terminal.
12	TA M	I	Inversion input terminal of tracking amplifier.	32	RF M	I	Inversion input terminal of RF summing amplifier.
13	TA O	O	Tracking drive output terminal.	33	LD	O	APC amplifier output terminal.
14	SL P	I	No-inversion input terminal of sled amplifier.	34	PHD	I	APC amplifier input terminal.
15	SL M	I	Inversion input terminal of sled amplifier.	35	PHD1	I	Inversion input terminal of RI I-V amplifier.
16	SL O	O	Sled drive output terminal.	36	PHD2	I	Inversion input terminal of RI I-V amplifier.
17	ISET	I	This terminal is flowed the current so that the focus search, tacking jump and sled kick height is decided.	37	FE BIAS	I	Bias adjust terminal of focus error amplifier.
18	VCC	I	Power supply terminal.	38	F	I	Inversion input terminal of F I-V amplifier.
19	CLK	I	Serial data transfer clock input from microprocessor.	39	E	I	Inversion input terminal of E I-V amplifier.
20	XLT	I	Latch input terminal for microprocessor.	40	EI	-	I-V amplifier E gain adjust terminal.
				41	VEE		GND
				42	TEO	O	Tracking error amplifier output terminal.
				43	LPFI	I	BAL adjust comparator input terminal.
				44	TEI	I	Tracking error input terminal.
				45	ATSC	I	Window comparator input terminal for ATSC detection.
				46	TZC	I	Tracking zero-cross comparator input terminal.
				47	TDFCT	I	Capacitor connection terminal for time constant when defect.
				48	VC	O	Mid-point voltage output terminal.

SM5877AN

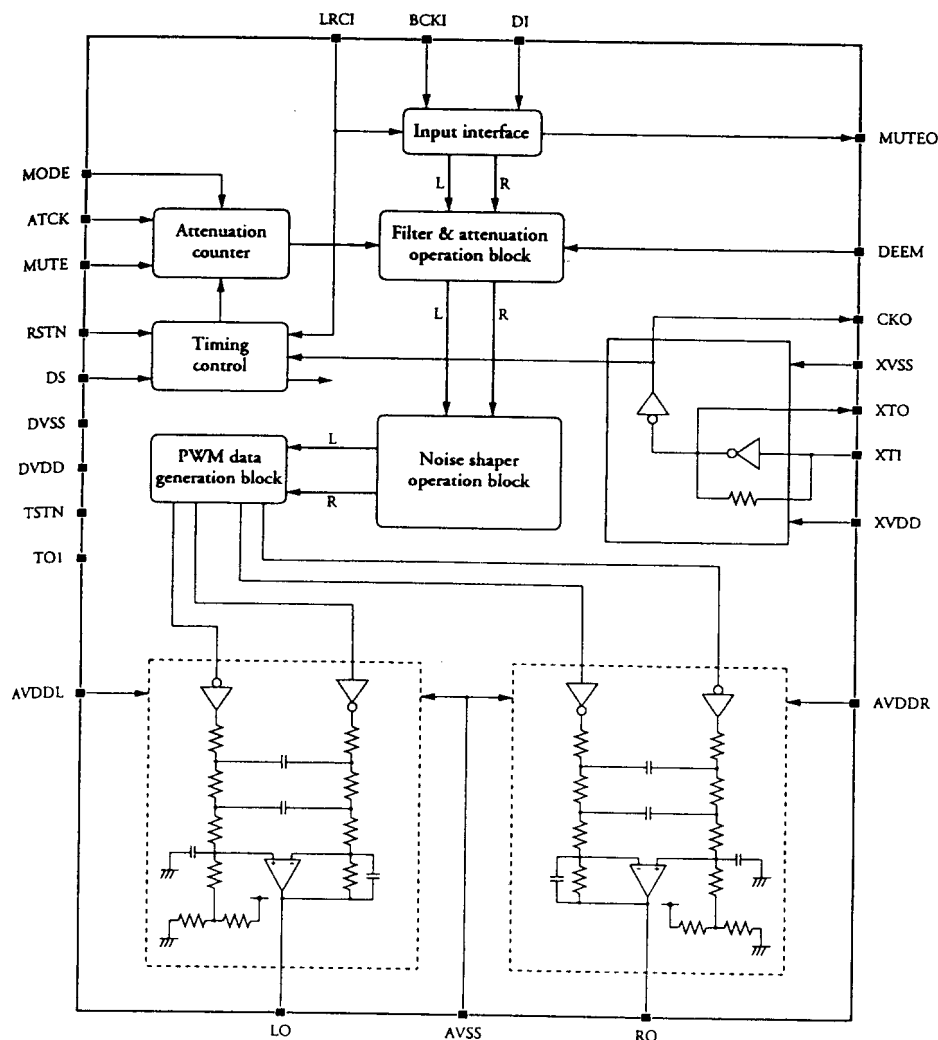

Pin No.	Symbol	I/O	Description
1	MUTE	Ip	MODE=H: Muting control pin. (at H: Mute) MODE=L: Attenuator level control pin. (at H: mode)
2	DEEM	Ip	De-emphasis control pin. (at H: De-emphasis ON)
3	CKO	O	Clock output pin. (16.9344MHz)
4	DVSS	-	Digital supply pin.
5	BCKI	Ip	Bit clock input pin.
6	DI	Ip	Serial data input pin.
7	DVDD	-	Digital supply pin.
8	LRCI	Ip	Sampling rate clock (fe) input pin. (at H: L ch, L: R ch)
9	TSTN	Ip	Test input pin.
10	TO1	O	Test output pin. (normal: L level)
11	AVDDL	-	Analogue supply pin for left channel.
12	LO	O	Analogue signal output pin for left channel.

Pin No.	Symbol	I/O	Description
13	AVSS	-	Analogue supply pin.
14	RO	O	Analogue signal output pin for right channel.
15	AVDDR	-	Analogue supply pin for right channel.
16	MUTE0	O	Infinitely zero detector output.
17	XVDD	-	Supply pin for resonator system.
18	XTI	I	Crystal connection or external clock input pin. (16.9344MHz)
19	XTO	O	Crystal connection pin.
20	XVSS	-	Supply pin for resonator system.
21	DS	Ip	Playback speed select pin. (at H: double speed)
22	RSTN	Ip	Reset pin. (at L: reset)
23	MODE	Ip	Muting/Attenuator mode select pin. (at H: muting mode)
24	ATCK	Ip	Attenuator level setting clock.

MICROPROCESSOR CONNECTION DIAGRAM (μ PD78043FGF)

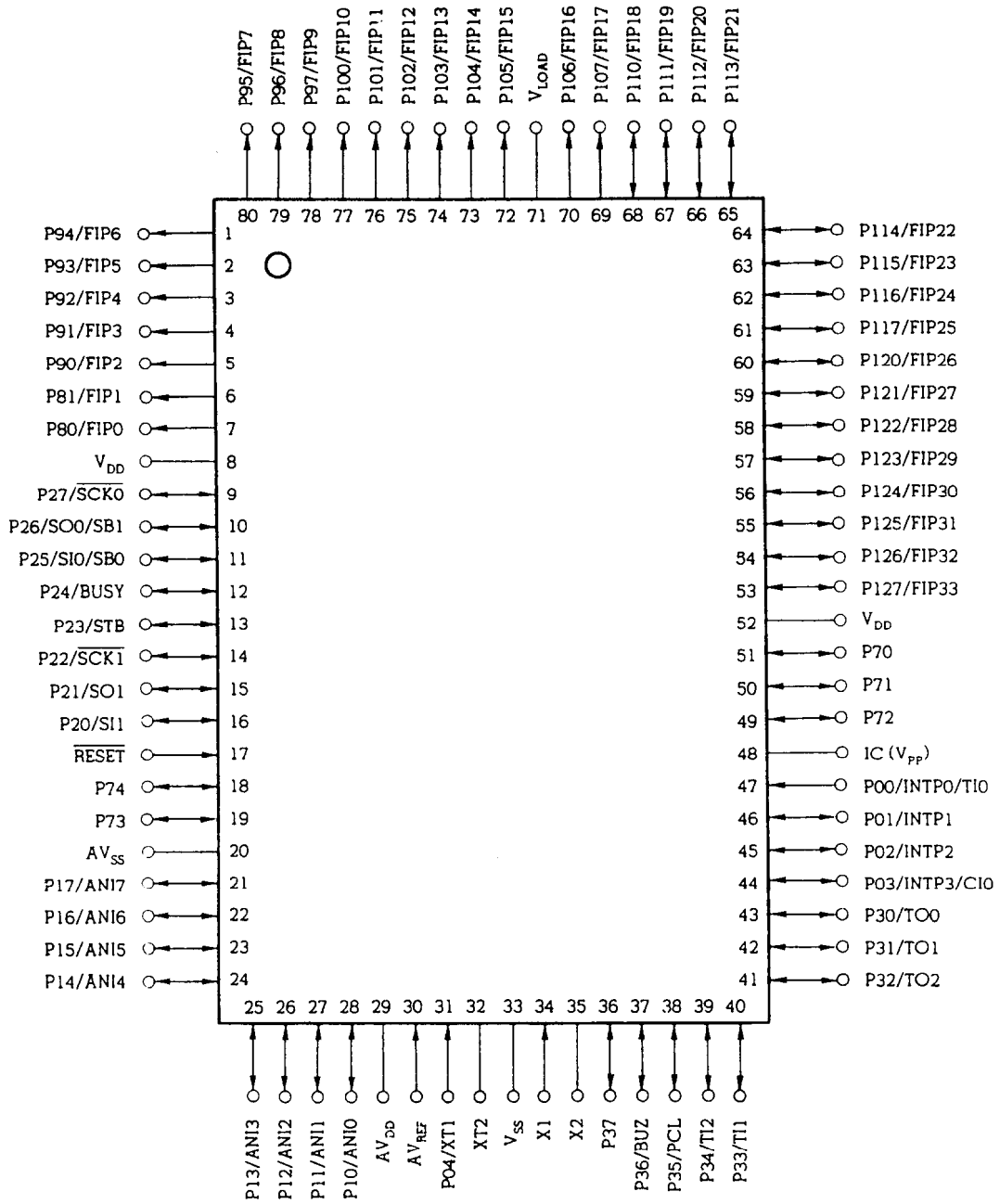

MICROPROCESSOR TERMINAL DESCRIPTION

Pin No.	Symbol	I/O	Description
1~2			Not used.(Open)
3~7	G4~G8	O	FL tube grid output.
8	VDD	I	Power supply terminal. +5V.
9	CLK	O	Command transfer clock output terminal to signal processor IC.
10	DATA	O	Command data output terminal to signal processor IC.
11	XLT	O	Command latch output terminal to signal processor IC.
12	MUT	O	Audio output digital mute signal output terminal.
13	SENS	I	Sens signal input terminal from processor IC.
14	SQCK	O	Sub cord transfer clock output terminal to signal processor IC.
15	GND	I	DX-C140/C340 selector terminal. (GND)
16	SQSO	I	Sub code input terminal from signal processor IC.
17	XRST	I	Reset signal input terminal.
18			Not used. (Open)
19			Not used. (Open)
20	GND	I	A/D converter GND for key input.
21	ROT.R	O	Roulette motor control output terminal.
22	ROT.L	O	Roulette motor control output terminal.
23	ROT.H	O	Roulette motor voltage control output terminal.
24	RI-OUT	I	System signal output terminal.
25~28	ADKEY3~ADKEY0	I	Key input terminal 3 ~0.
29	AVDD	I	A/D converter power supply terminal for key input. +5V.
30	AVREF	I	A/D converter reference voltage input terminal for key input. +5V.
31	RI.INPUT	I	System signal input terminal.
32	XT2		Not used.
33	GND	I	GND
34	X1	I	Clock oscillator circuit input terminal.
35	X2	O	Clock oscillator circuit output terminal.
36		I	Not used. (GND)
37	C.OUT	I	Track counter input terminal from RF amp.
38	DISC. SENSOR	I	Disc sensor input terminal of on the tray.
39	LD.CURRENT	I	Tray motor current reference input terminal.
40	CH.OPEN SW	I	Chucking open detection switch input terminal
41	CH.CLOSE SW	I	Chucking close detection switch input terminal
42	LD.OPEN SW	I	Loading motor open detection switch input terminal.
43	LD.CLOSE SW	I	Loading motor close detection switch input terminal.
44	CH.OPEN	O	Chucking open motor control output terminal.
45	CH.CLOSE	O	Chucking close motor control output terminal.
46	SCOR	I	Sub code block detector signal input terminal from signal processor IC.
47	RMCN	I	Remote control signal input terminal
48	GND	I	Microprocessor internally connect terminal.(connected to GND)
49	FGD	O	Focus gain down control output terminal. (Not used)
50	ROT.STOP.SENS	I	Roulette stop position detection input terminal.
51	ROT.POS.SENS	I	Roulette position detection input terminal.
52	VDD	I	Power supply terminal. +5V.
53	LD.OPEN	O	Loading motor open control output terminal.
54	LD.CLOSE	O	Loading motor close control output terminal.
55~60			Not used. (Open)
61~70	P16~P7	O	FL tube segment output terminal.
71	-VFIP	I	Negative power supply terminal for FL tube.
72~77	P6~P1	O	FL tube segment output terminal.
78~80			Not used. (Open)

CARE SHOULD BE TAKEN WITH THE OPTICAL PICK-UP

The laser diode in the optical pickup block is so sensitive to static electricity, surge current and etc. that the components are liable to be broken down or its reliability remarkably deteriorated.

During repair, carefully take the following precautions.

1. When replacing the optical pickup, first short the LD terminals and remove the connector. Also, when attaching the new optical pickup, after attaching the connector, unsolder the LD terminals.
2. Do not touch the optical pickup object lens with the hands.

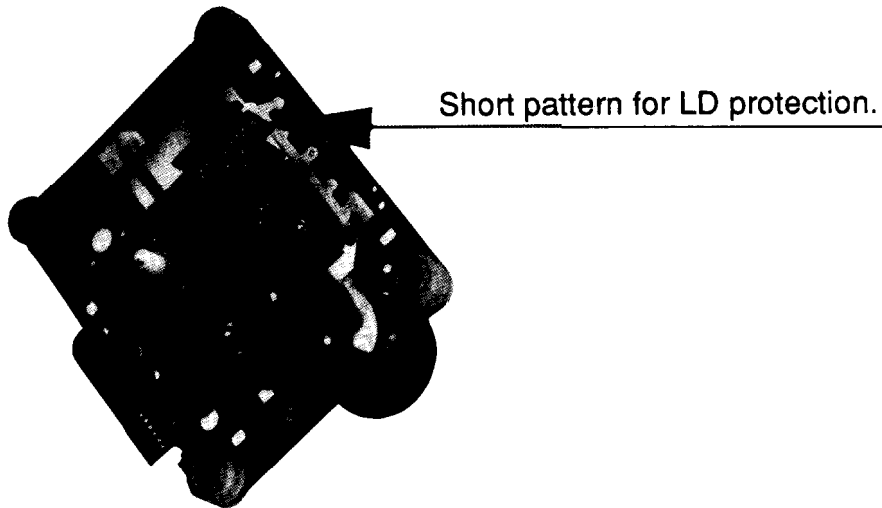

To shipping position

1. Press and hold down the DISC 6 button, then press the POWER button.
2. "INITIALING" is displayed.
3. Press the power switch while "POWER OFF" is displayed.

ADJUSTMENT PROCEDURES

Instruments required

Dual trace oscilloscope, Frequency counter, AF oscillator, Test disc (SONY YEDS-18) and AC voltmeter.

1. Focus offset adjustment

Turn R108 and R126 to the mechanical center.

Load the test disc YEDS-18 on the tray and play the track 2.

Connect the oscilloscope to terminal P106.

Adjust R108 until the waveform on the oscilloscope becomes maximum.

After adjustment, disconnect the oscilloscope.

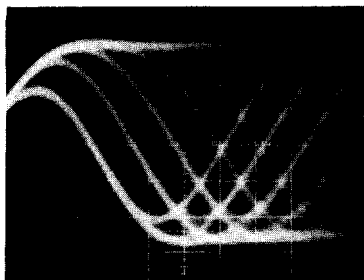
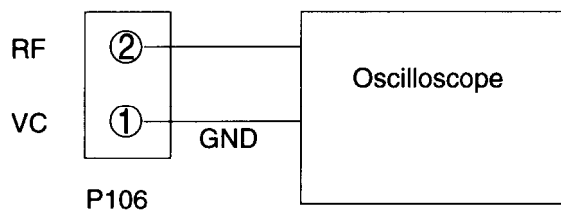

Photo 1

0.2V/div

0.2 μ s/div



2. Focus gain adjustment

Set the output of AF oscillator to 1kHz, -2 Vp-p.

Play the track 2 of test disc.

Connect the oscilloscope and the AF oscillator as shown below.

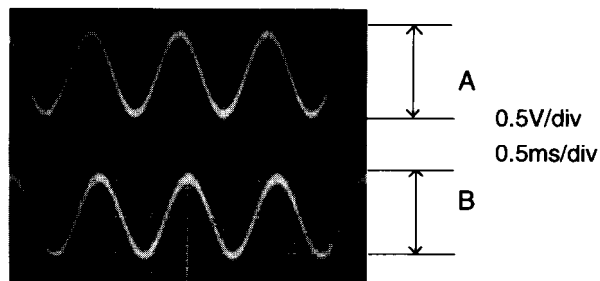
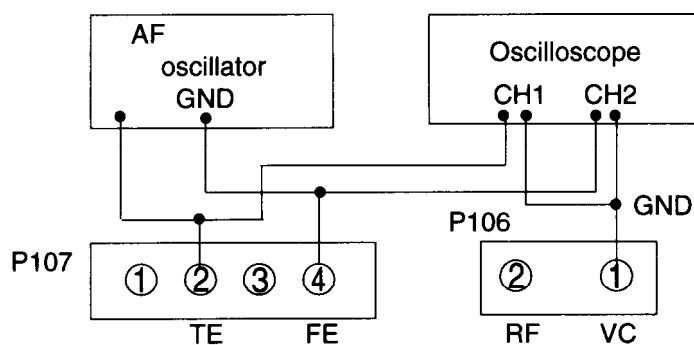

Photo 2



Adjust R126 until 1kHz components of channels 1 and 2 on oscilloscope become same level.

After adjustment, disconnect the AF oscillator and the oscilloscope.

PICK-UP DRIVE UNIT

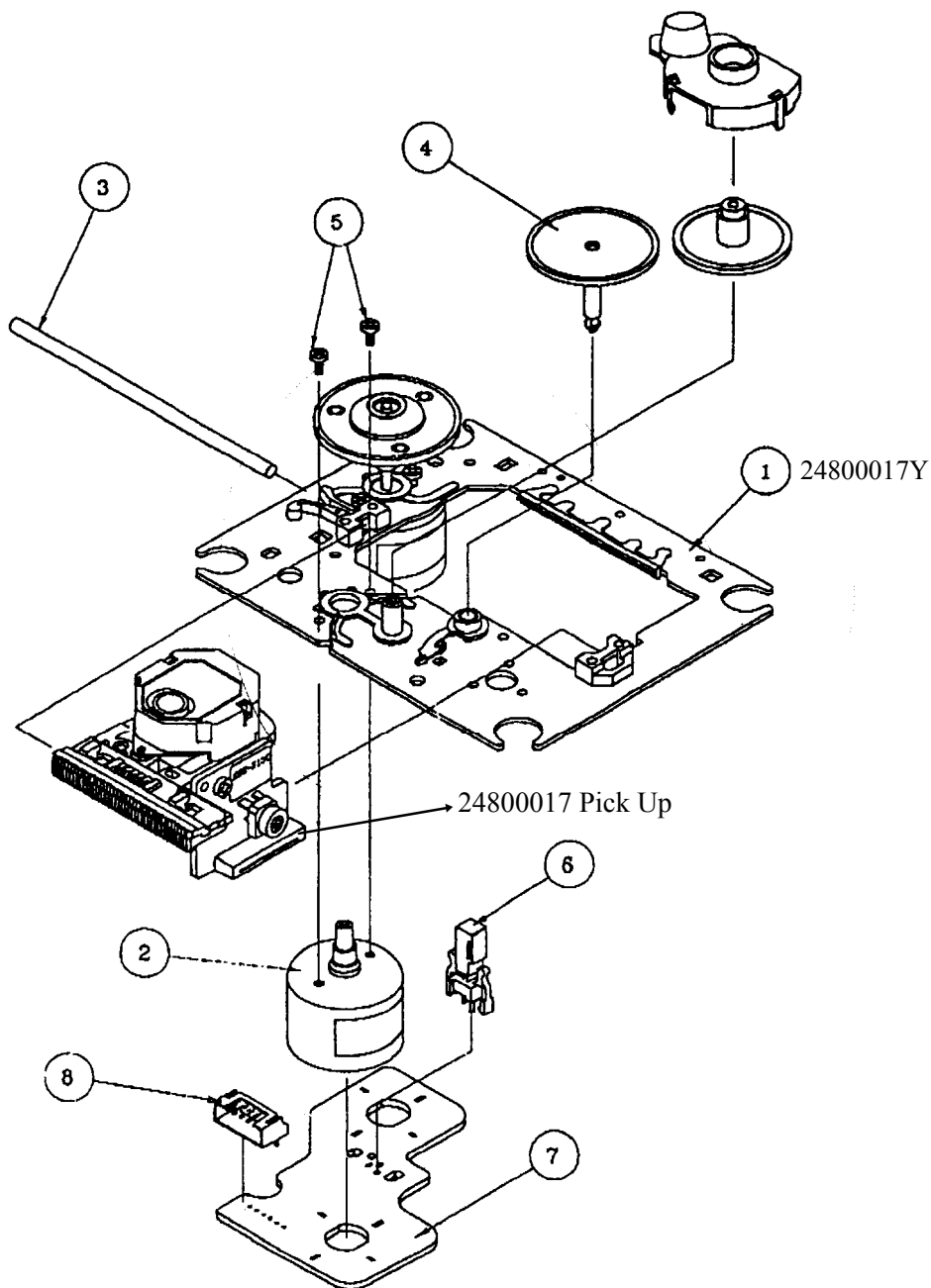

REF.NO.	PART NO.	DESCRIPTION
1	24800017Y	Motor chassis ass'y (MB)
2	X2625-769- 1	Motor gear ass'y
3	2626-908- 01	Sled shaft
4	2626-907- 01	Gear (A)(S)
5	7621-255- 15	Screw +P2x3
6	1572-085- 11	Leaf switch
7	1639-678- 12	Motor (6P) (S) PCB
8	1564-722- 11	Connector pin 6P

TROUBLE SHOOTING

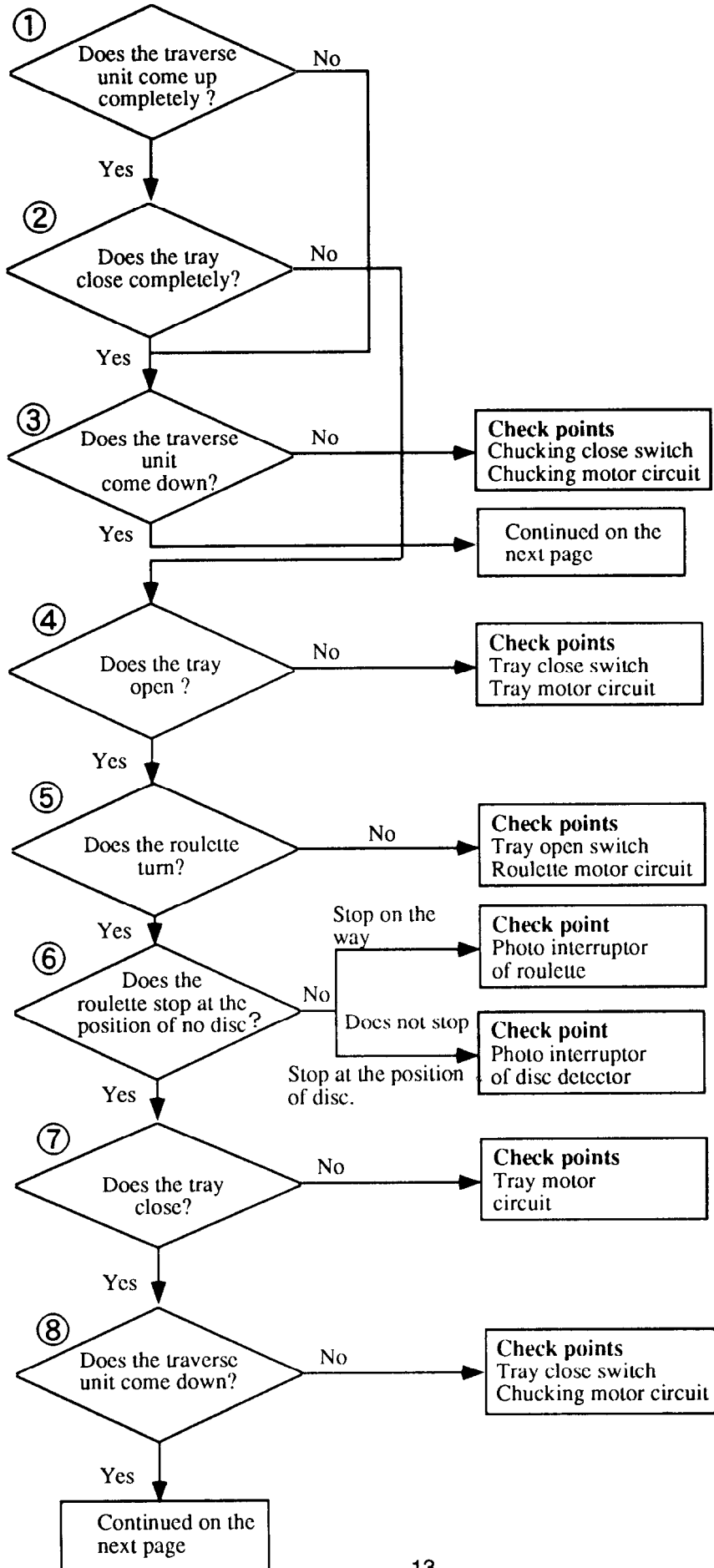

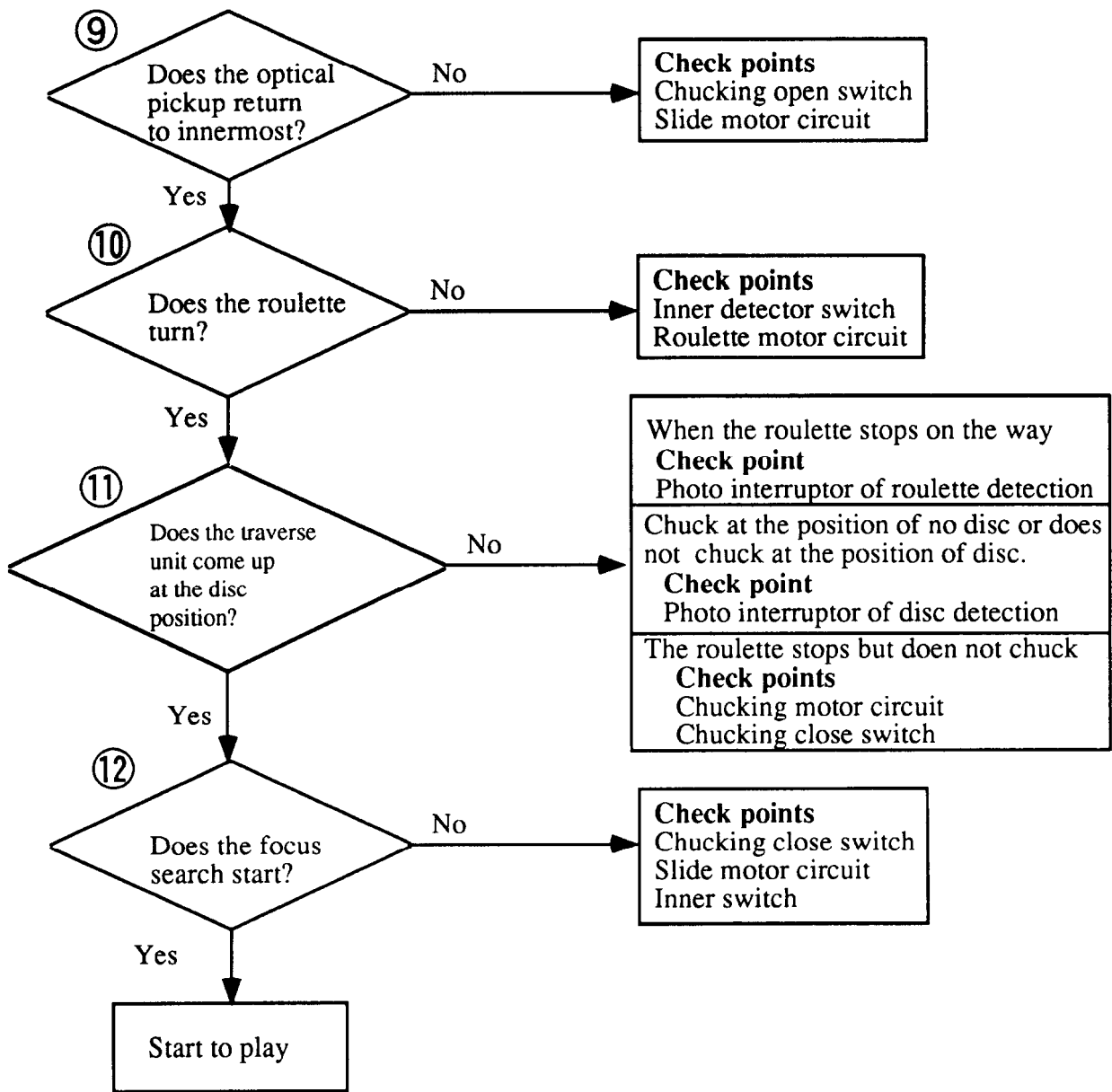

INITIALIZING OPERATION

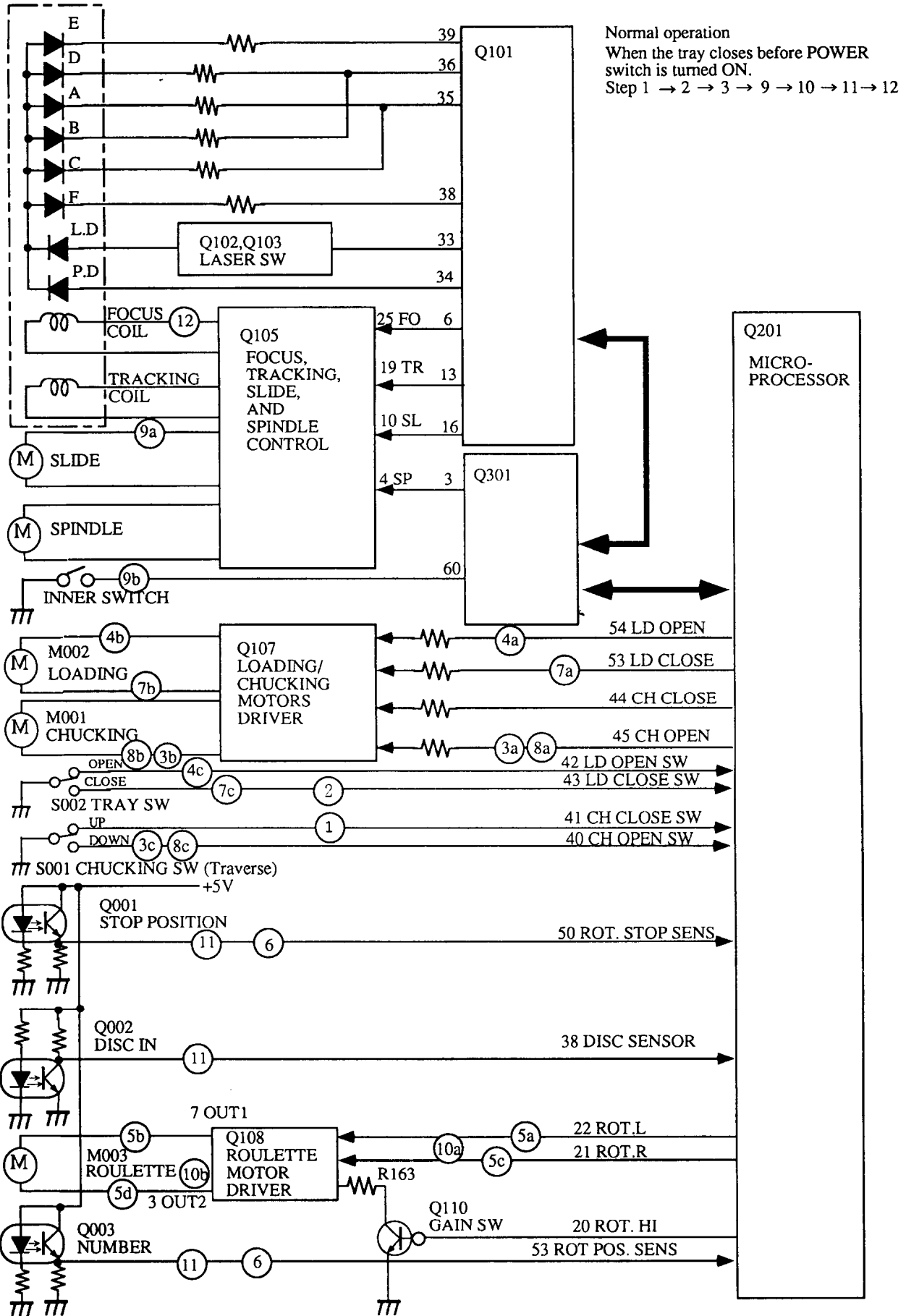

ERROR MESSAGE DISPLAYED IN HEAT-RUNNING MODE

Heat-running Mode : Power ON as pushing DOWN button together.

Operation :

1. DISC 1 chucking and TOC Reading (Pick-up Home position is displayed.)
2. Accessing of the Outermost Track
3. Tray Open
4. Tray Close
5. DISC 1 Playing / Stop and Chucking Down
6. Roulette Turning 7/6 Turns clockwise

Then,

1. DISC 2 chucking and TOC Reading (Pick-up Home position is displayed.)
2. Accessing of the Outermost Track
3. Tray Open
4. Tray Close
5. DISC 2 Playing / Stop and Chucking Down
6. Roulette Turning 5/6 Turns counter-clockwise

Then,

Continued as the above.

In these operation Error Message is shown in the display if any error occurs in the mechanism or the servo control. And then you can find the failure point almost exactly in this mode before you repair rejected units.

1. nf : FOCUS NG : FOCUS SERVO ON missed (Failure in Laser or RF circuit)
2. ng : GFS NG : TIMEOUT for Non-GFS (Synchronous Signal Detection) (Failure in RF Demodulator or CLV)
3. Ld : TOC Reading NG : TIME OUT Before TOC Reading completion (All SERVO Circuit)
4. Ac : ACCESS NG : TIME OUT before ACCESS completion (All SERVO Circuit)
5. co : CH OPEN NG : Non-CHUCKING Open
6. cc : CH CLOSE NG : Non-CHUCKING Close
7. rL : ROT LEFT NG : Non CCW Turning of Roulette or Non-Detection of CCW Turning of Roulette
8. rr : ROT RIGHT NG : Non CW Turning of Roulette or Non-Detection of CW Turning of Roulette
9. OP : TRAY OPEN NG : Non TRAY Open
10. CL : TRAY CLOSE NG : Non TRAY Close
11. PU : PICK UP RETURN NG : PICK-UP Non Return to the inner most.

There are two Errors in the normal operation as follows.

1. Er : INITIALIZE ERROR : Error occurred in Mechanism when it is initialized. (Error points are displayed in Heat-running Mode.)
2. rn : RAM NG : RAM for File is not initialized.

Canceling the heat-running mode: Unplug the power cord of the unit from the wall outlet.

CHASSIS EXPLODED VIEW PARTS LIST

REF. NO.	PART NO.	DESCRIPTION
A1	27111011Y	Front bracket
A2	838130088	3TTB+8B, Self-tapping screw
A3	28191788A	Clear plate
A4	28325465Y	Knob (POW)
A5	27270400	Spacer (POW)
A6	27100327Y	Chassis
A7	27191000Y	Holder (MFS)
A8	260208	Wire tie
A9	28325519Y	Knob (TEN)
A13	27175316B	Leg
A14	28141332Y	Cushion
A17	27300750	△ Cord bushing #2271
A19	29361957Y	Label (ALL2)
A20	831430088	3TTW+8(BC), Self-tapping screw
A22	27300833Y	Clump, WS-2NS
A23	27301779	Clump, HI-38-0
A24	838430107Y	3TTB+10S(BC), Self-tapping screw
A51	27122350Y	Rear panel <D>
	27122351Y	Rear panel <P,PA>
	27122428Y	Rear panel <PT>
A301	28184680Y	Top cover
A302	838430088Y	3TTB+8B(BC)
A501	27211932Y	Front panel
A502	28135244Y	Badge
A506	28148365Y	Door
E1	204338006Y	NCFC3-38006, Flexible flat cable
E2	204307007	NCFC3-07007, Flexible flat cable
P951	253192HIT	△ AS-UC-6#18, AC Cord <D>
	253193HIT	△ AS-CEE, 250V 2.5A, AC Cord <P,PT>
	253197HIT	△ AS-SAA, AC Cord <PA>
T901	2301272Y	△ NPT-1302D, Power transformer <D>
	2301273Y	△ NPT-1302P, Power transformer <P,PT,PA>
U1	1H360564-1AY	NAAR-6064-1A, Main circuit pc board
U2	1H360565-1AY	NADIS-6065-1A, Display circuit pc board
U3	1H360567-1AY	NAPS-6067-1A, Power supply circuit pc board
U4	1H360568-1AY	NASW-6068-1A, Power switch pc board
U5	1H360566-1AY	NASW-6066-1A, Ten key pc board
U11	1H357554-1Y	NAETC-5854, Position sensor pc board
U12	1H357555-1Y	NAETC-5855, Chacking motor pc board
U13	1H357556-1Y	NAETC-5856, Loading motor pc board
U14	1H357557-1Y	NASW-5857, Chacking switch pc board
U15	1H357558-1Y	NASW-5858, Roullet in/out pc board
U16	1H357559-1Y	NAETC-5859, Disc sensor pc board

NOTE: <D> 120V model only
 <P> 230V model only
 <PT> Taiwanese model only
 <PA> Australia model only

NOTE: THE COMPONENTS IDENTIFIED BY MARK
 △ ARE CRITICAL FOR RISK OF FIRE AND
 ELECTRIC SHOCK. REPLACE ONLY WITH
 PART NUMBER SPECIFIED.

CHANGER MECHANISM PARTS LIST

REF. NO.	PART NO.	DESCRIPTION
M2	24840109	Rail
M3	28141337	Cushion
M6	24830004Y	Yoke (CHB)
M7	24824006Y	Cap (CHC)
M8	24832006Y	Magnet (CHB)
M10	24804015Y	Motor (RF-500TB-14415)
M11	24810028Y	Pulley
M12	24816010AY	Rubber belt (B)
M15	24810040Y	Gear (PULLEY)
M16	24810039A	Gear (LOAD)
M17	24810041Y	Cam gear (A)
M18	24810042Y	Cam gear (B)
M20	831430088Y	3TTW+8B(BC), Self-tapping screw
M23	24802024Y	Chassis (SUB)
M24	24840111Y	Self-tapping screw
M25	24800017Y	Mecha unit (KSM-213CCM)
M26	24818013Y	Insulator (A)
M27	24818014Y	Insulator (B)
M28	204416004Y	Flexible flat cable (NCFC4-16004)
M29	2009990464	Socket AS (NSAS-12P0618)
M30	24840111Y	Self-tapping screw
M33	24840107Y	Tray
M34	24804021Y	Motor (RF-310TA-11400)
M35	24810047	Pulley (B)
M36	24822018Y	Retainer
M37	838130088Y	3TTB+8B, Self-tapping screw
M38	28141335Y	Cushion
M40	24810045Y	Worm AS
M43	24810043Y	Wheel gear
M44	831430088Y	3TTW+8B(BC), Self-tapping screw
M45	24834017Y	Spacer
M46	24840111Y	Self-tapping screw
M47	24816104	Rubber belt (F)
M48	24840110Y	Roller
M49	28141340	Cushion
M50	24840108Y	Roulette
M51	24834016Y	Washer (A)
M52	24820033Y	Spring (A)
M53	24840111Y	Self-tapping screw
M58	838130088Y	3TTB+8B, Self-tapping screw
M59	838426088Y	2.6TTB+8B(BC), Self-tapping screw

CHASSIS EXPLODED VIEW

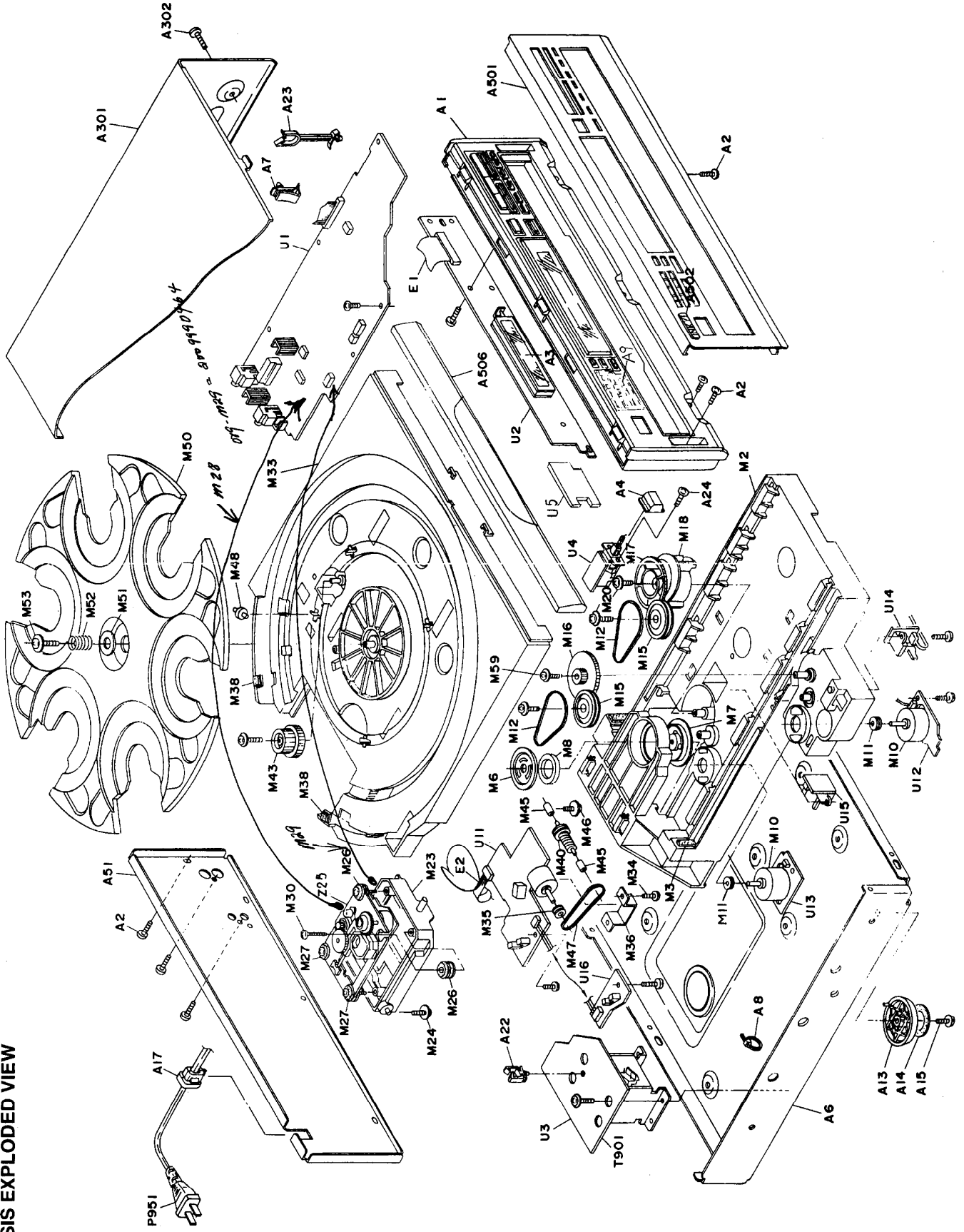

BLOCK DIAGRAM

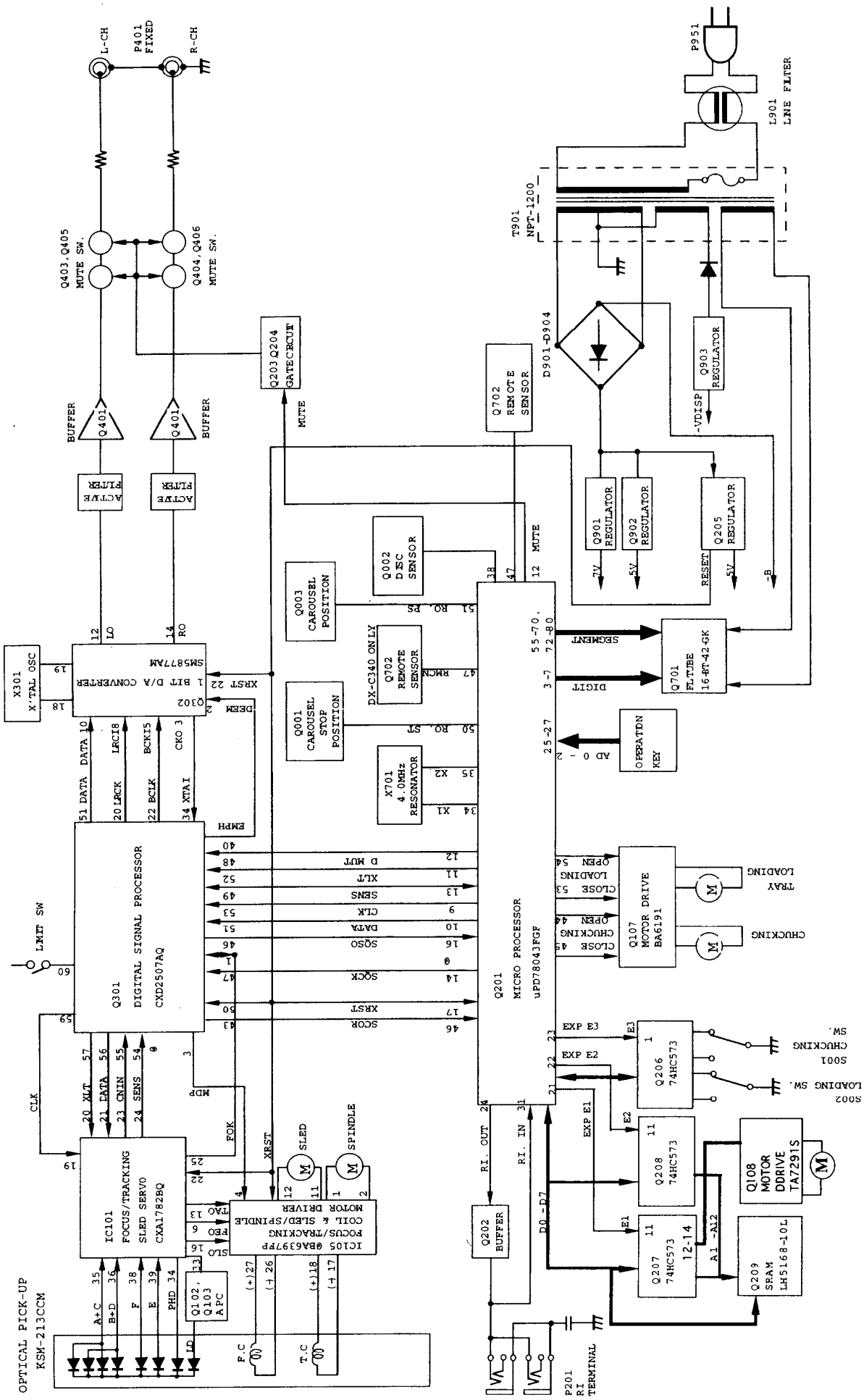

A B C D E F G

SCHEMATIC DIAGRAM

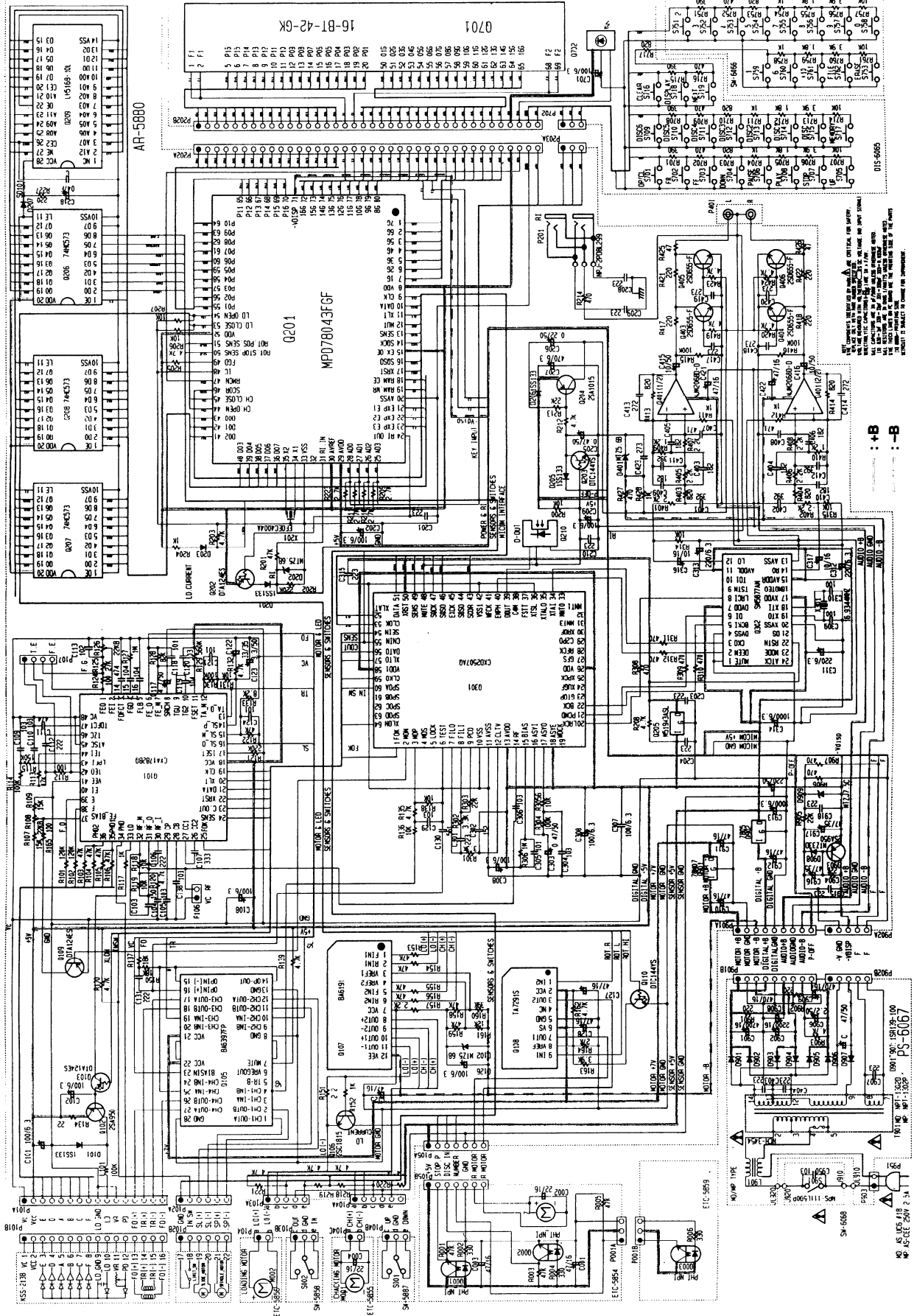

PRINTED CIRCUIT BOARD -PARTS LIST

U1 MAIN CIRCUIT PC BOARD (NAAR-6064-1A)

CIRCUIT NO.	PART NO.	DESCRIPTION
	ICs	
Q101	22241093	CXA1782BQ
Q105	22241066	BA6398FP
Q107	22240771	BA6191
Q108	22240239	TA7291S
Q201	22241094	MPD78043FGF-026
Q205	22240018	M51943A
Q206-Q208	222745735ROHI	HD74HC573FP
Q210	22241065	LH5164N-10L
Q211	24120038	GP1F32T
Q301	22241096	CXD2507AQ
Q302	22241074R9	SM5877AM
Q401	222956	NJM2068D-D
Q901	222780075	78M07HF
Q902	222780054	7805HF
	Transistors	
Q102,Q903	2211504	2SA950-Y
Q103,Q109,Q202	2212600	DTA124ES
Q106	2211255	2SC1815-GR
Q110,Q203	221282	DTC144ES
Q204	2211455	2SA1015-GR
Q403-Q406	2211706	2SD655-F
	Diodes	
D101,D201,D203, D205,D206	223205 or 223163	1SS270A or 1SS133
D102,D202,D401	224470562	MTZJ5.6B, Zener
D207	223191	SD101
D908	224473004	MTZJ30D, Zener
D909	224470753	MTZJ7.5C, Zener
	Capacitors	
C101,C102,C126, C202,C217,C308	354721019	100 μ F, 6.3V, Elect.
C105,C109,C110, C120,C129,C138, C304,C306	374721034	0.01 μ F \pm 5%, 50V, Plastic
C106,C112,C131, C301,C413,C414	374722224	2200pF \pm 5%, 50V, Plastic
C107	374723334	0.033 μ F \pm 5%, 50V, Plastic
C111,C114	374724744	0.47 μ F \pm 5%, 50V, Plastic
C113	374721024	1000pF \pm 5%, 50V, Plastic
C115,C116,C119	374721044	0.1 μ F \pm 5%, 50V, Plastic
C117	354780479	4.7 μ F, 50V, Elect.
C122	354763309	33 μ F, 35V, Elect.
C123	354780339	3.3 μ F, 50V, Elect.
C125,C127,C128, C135,C421,C422, C910-C912	354744709	47 μ F, 16V, Elect.
C205,C303	354784799	0.47 μ F, 50V, Elect.
C206	354782299	0.22 μ F, 50V, Elect.
C207,C211,C913	354721029	1000 μ F, 6.3V, Elect.
C212	354782219	220 μ F, 50V, Elect.
C218	3000064	0.47F, 5.5V Super
C302	374721524	1500pF \pm 5%, 50V, Plastic
C311-C314	354722219	220 μ F, 6.3V, Elect.
C316,C317	354741009	10 μ F, 16V, Elect.
C401,C402	374723924	3900pF \pm 5%, 50V, Plastic
C403-C406,C409, C410	374721824	1800pF \pm 5%, 50V, Plastic
C407,C408	374724714	470pF \pm 5%, 50V, Plastic
C411,C412	374723924	3900pF \pm 5%, 50V, Plastic
C415,C416	354781009	10 μ F, 50V, Elect.
C417-C420,C423	374722734	0.027 μ F \pm 5%, 50V, Plastic
C916,C917	354764709	47 μ F, 35V, Elect.
	Resistors	
R108,R126	5210263	N06HR, 20KBC, Trim
	Ceramic lock	
X201	3010229	EFOEC4004S4

CIRCUIT NO.	PART NO.	DESCRIPTION
X301	Resonator 3010159	AT-38-169, Crystal
	Holder 27190751	X301
	Coil 233454K100	NCH-1452, 100K
L101	Sockets 25051768	NSCT-16P1555
P101	25051851	NSCT-7P1638
P105A	25051836	NSCT-29P1623
P202A	Plugs 25055150	NPLG-6P134
P102A	25055149	NPLG-5P133
P103A	25055150	NPLG-6P134
P104A	25055038	NPLG-2P29
P106	25055045	NPLG-4P33
P107	Jacks 25045330	NPJ-2PDBL184, RI
P201	25045353	NPJ-2PDBL199, Line out
P401	Radiators 27160145-1Y	RAD51, Q901A,Q902A

U2 DISPLAY CIRCUIT PC BOARD (NADIS-6065-1A)

CIRCUIT NO.	PART NO.	DESCRIPTION
Q701	FL tube 212150	16-BT-42GK
Q702	Remote sensor 24130011	PIC-12043TE2
C701	Capacitor 353721019	100 μ F, 6.3V, Elect.
S701-S719	Switches 25035652 or 25035652MAT	NPS-111-S604 or NPS-111-S624
P202B	Holder 27190979A	Holder (FL)
	Socket 25051882	NSCT-38P1669

U3 POWER SUPPLY CIRCUIT PC BOARD (NAPS-6067-1A)

CIRCUIT NO.	PART NO.	DESCRIPTION
D901-D907	Diodes 22380260 or 22380035	Δ RL1N4003 or Δ GP104003E
L901	Coil 231222	Δ NCH-3454, Line filter
C901	Capacitors 354744729	4700 μ F, 16V, Elect.
C902	393342227	2200 μ F, 16V, Elect.
C905	354784709	47 μ F, 50V, Elect.
C906	354780229	2.2 μ F, 50V, Elect.
C908,C909	354744719	470 μ F, 16V, Elect.
P903	Plug 25055676	NPLG-2P632

U4 POWER SWITCH PC BOARD (NASW-6068-1A)

CIRCUIT NO.	PART NO.	DESCRIPTION
C950	Capacitor 3500191	Δ DE7150F 103M, AC400V/125V, IS C
S901	Switch 25035636	Δ NPS-111-L590P, Power

U5 TEN KEY PC BOARD (NASW-6066-1A)

CIRCUIT NO.	PART NO.	DESCRIPTION
	Switches	
S751-S763	25035652 or 25035652MAT	NPS-111-S604 or NPS-111-S624

U11 POSITION SENSOR PC BOARD (NAETC-5854-1)

CIRCUIT NO.	PART NO.	DESCRIPTION
	Photo intercouple	
Q001	24190041	SG-207
Q002	24190046	GP2S28
	Capacitors	
C001,C003	354744709	47 μ F,16V, Elect.
C002	352942206	22 μ F,16V, Elect.
	Socket AS	
P001A	2002390650UL	NSAS-6P0597
P103	2009990447UL	NSAS-10P0596
P104	2009990446UL	NSAS-11P0595
	Socket	
P105B	25051851 or 25050913	NSCT-7P1638 or NSCT-7P700

U12 CHUKING MOTOR PC BOAR (NAETC-5855-1)

CIRCUIT NO.	PART NO.	DESCRIPTION
	Capacitor	
C004	352942206	22 μ F,16V, Elect.

U14 SWITCH PC BOARD (NASW-5857-1)

CIRCUIT NO.	PART NO.	DESCRIPTION
	Switch	
S002	25065491	NMS-1223, Micro

U15 Chucking Switch PC BOARD (NASW-5858-1)

CIRCUIT NO.	PART NO.	DESCRIPTION
	Switch	
S001	25065375	NMS-1219, Micro

U16 DISC SENSOR PC BOARD (NAETC-5859-1)

CIRCUIT NO.	PART NO.	DESCRIPTION
	Photo intercouple	
Q003	24190041	SG-207
	Plug	
P001B	25055367	NPLG-3P350

NOTE: THE COMPONENTS IDENTIFIED BY MARK \triangle ARE CRITICAL FOR RISK OF FIRE AND ELECTRIC SHOCK. REPLACE ONLY WITH PART NUMBER SPECIFIED.

PACKING VIEW

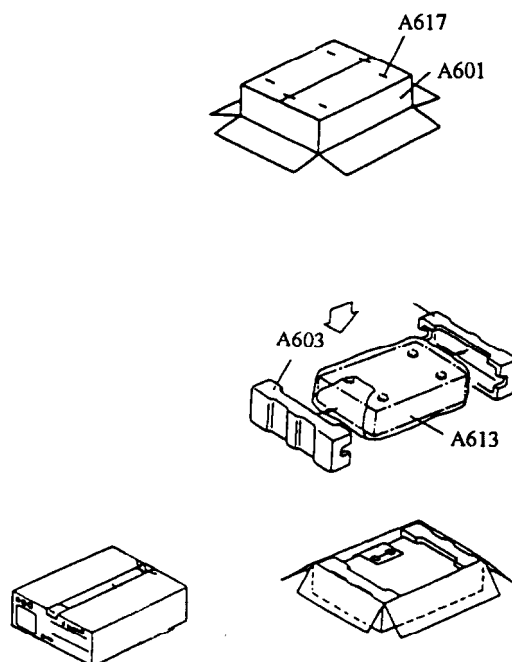

PACKING VIEW PARTS LIST

REF. NO.	PART NO.	DESCRIPTION
A601	29053172Y	Carton box
A603	29091774A	Pad (AS)
A613	29100153Y	Poly bag 720x1020
A617	282321Y	Staple
A604	29095795	Sheet (DR)
	Accessory bag ass'y	
	29342521	Instruction manual, E
	29342523	Instruction manual, U3(G,SW,D) <P>
	29342522	Instruction manual, U3(F,S,I) <P>
	29342524	Instruction manual, T <PT>
	29365019BY	Warranty card
	29358002KY	Station list
	2010244Y or	Pin Cord AS
	2010098A or	
	2010326Y	
	2010200Y	3.5mini plug, RI
	24140337Y	RC-337C, Remote control
	3010054 or	UM-3, Battery
	3010165Y	
	27270397Y	Spacer, chassis
	29100097-1AY	Poly bag 350x250
	29360840Y	Label (Sheet)
	29362037-1Y	Label (UPC)AS
	29362108Y	Label (EAN)AS <P,PT,PA>
	29361786	Label (Malaysia) <PT>

NOTE: <D> 120V model only
 <P> 230V model only
 <PA> Australia model only
 <PT> Taiwanese model only

ONKYO CORPORATION

International Sales Div.: 31 Sankyo-bld. 3-8-5, Asakusabashi, Taito-ku, TOKYO 111, JAPAN
TEL : 03-5820-5865 FAX : 03-5820-5869

ONKYO U.S.A. CORPORATION
200 Williams Drive, Ramsey, N.J. 07446, U.S.A.
TEL : 201-825-7950 FAX : 201-825-8150

ONKYO EUROPE ELECTRONICS GmbH
Industriestrasse 18-20, 82110 Germering, GERMANY
TEL : 089 84 93 20 FAX : 089 84 93 226

ONKYO FRANCE
Immeuble Le Diamant, Domaine Technologique de Saclay, 4 Rue Rene Razel, 91892 SACLAY, FRANCE
TEL : (1) 69 33 1400 FAX : (1) 69 41 35 84