

ONKYO® SERVICE MANUAL

PORTABLE CD PLAYER MODEL DX-F771



UD	120V AC, 60Hz
UP	230V AC, 50Hz

SAFETY-RELATED COMPONENT WARNING !!

COMPONENTS IDENTIFIED BY MARK \triangle ON THE SCHEMATIC DIAGRAM AND IN THE PARTS LIST ARE CRITICAL FOR RISK OF FIRE AND ELECTRIC SHOCK. REPLACE THESE COMPONENTS WITH ONKYO PARTS WHOSE PARTS NUMBERS APPEAR AS SHOWN IN THIS MANUAL.

MAKE LEAKAGE-CURRENT OR RESISTANCE MEASUREMENTS TO DETERMINE THAT EXPOSED PARTS ARE ACCEPTABLY INSULATED FROM THE SUPPLY CIRCUIT BEFORE RETURNING THE APPLIANCE TO THE CUSTOMER.

SPECIFICATIONS

Signal readout system:	Optical non-contact
Error correction system:	Cross Interleave Reed Solomon code
D/A converter:	1 BIT D/A converter
Sampling frequency:	352.8 kHz (Eight-times oversampling)
Number of channels:	2 (stereo)
Frequency response:	20 Hz - 20 kHz
Wow and Flutter:	Below threshold of measurability
Output level:	15mW × 2 (headphone)
Power supply rating:	AC 120 V, 60Hz (UD type) AC 230V, 50Hz (UP type) 3V: Using two AA batteries 3V: Using the rechargeable battery
Dimensions (W × H × D):	129 × 32 × 163 mm 5-1/8" × 1-1/4" × 6-7/16"
Weight:	0.3 kg, 11.4 oz (main unit only)
Specifications and external appearance are subject to change without notice because of product improvements.	

ONKYO
AUDIO COMPONENTS

SAFETY CERTIFICATION

This Compact Disc Player is made and tested to meet exacting safety standards. It meets UL and FCC requirements and complies with safety performance standards of the U.S. Department of Health and Human Services.

Laser Diode Properties
Material: Ga-Al-As
Wavelength: 755 – 815 nm (25°C)
Laser Output: Continuous Wave max.0.5 mW

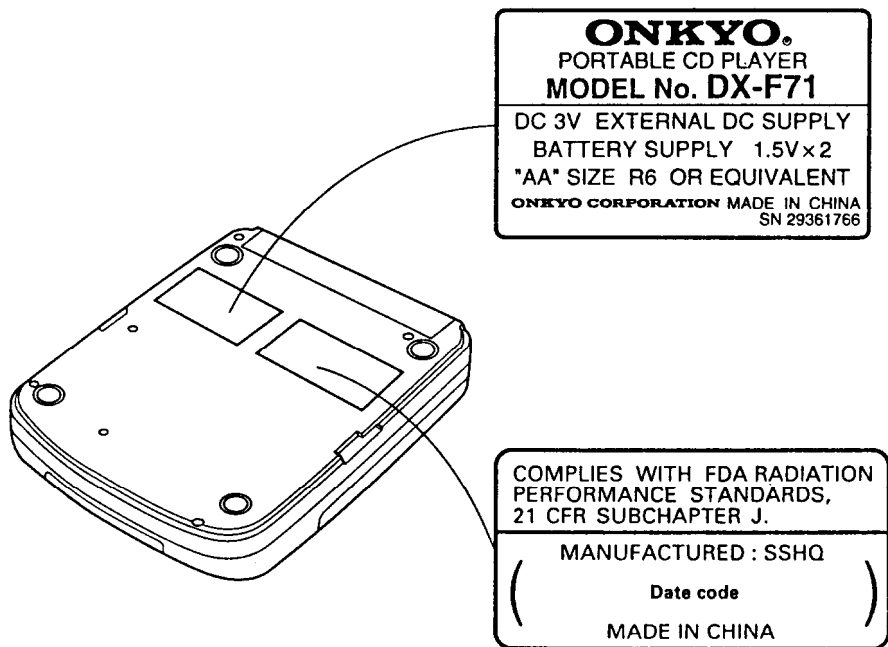

CAUTION – USE OF CONTROLS OR ADJUSTMENTS OR PERFORMANCE OF PROCEDURES OTHER THAN THOSE SPECIFIED HEREIN MAY RESULT IN HAZARDOUS RADIATION EXPOSURE.

THE COMPACT DISC PLAYER SHOULD NOT BE ADJUSTED OR REPAIRED BY ANYONE EXCEPT QUALIFIED SERVICE PERSONNEL.

LASER BEAM RADIATION SPOT

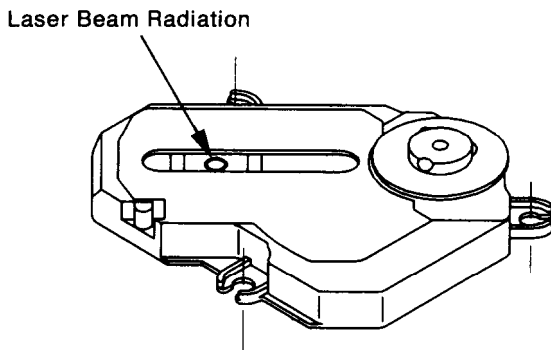

BLOCK DIAGRAM

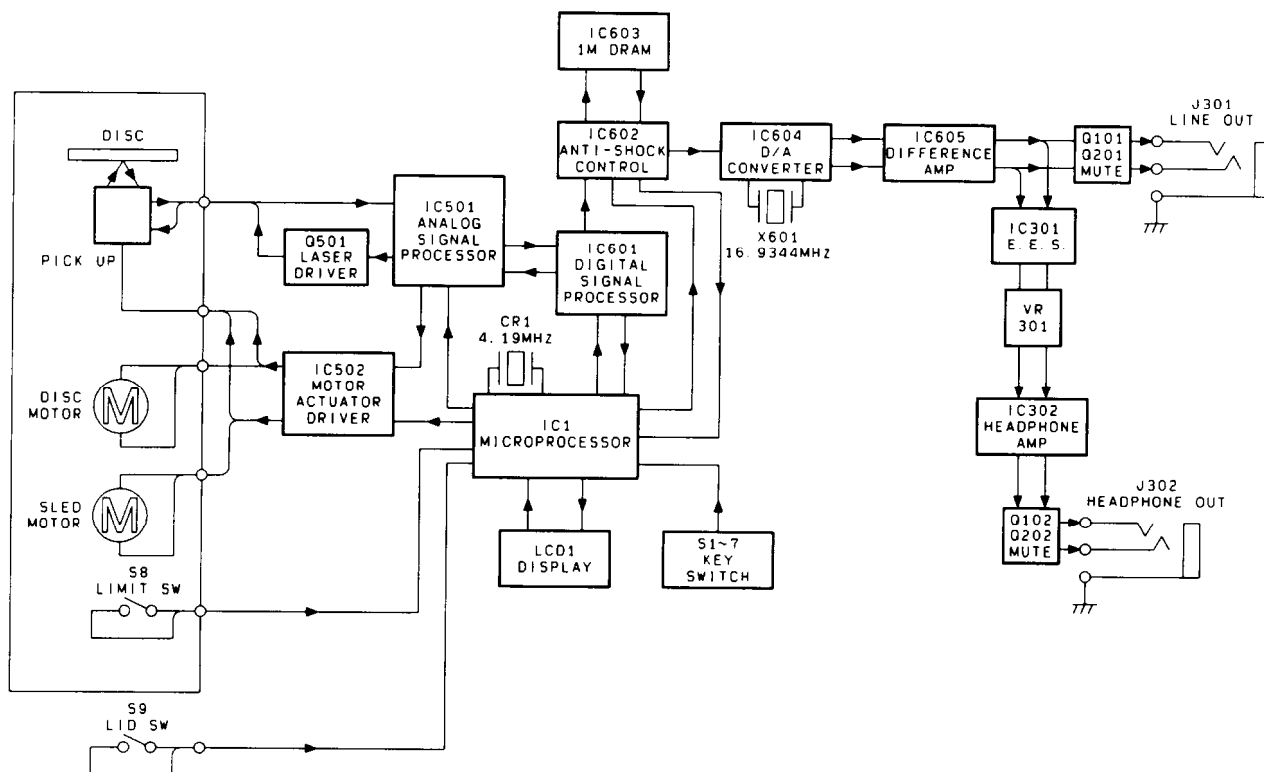

DISASSEMBLY INSTRUCTIONS

When disassembling this unit, be sure of the following:

- Before disassembling the unit, spread a soft rubber mat or a cloth on the workbench to avoid scratches and grease stains.
- Before disassembling the unit, take out the compact disc and the batteries and then turn off the power switch and unplug the AC adapter.
- Do not use a material which is likely to cause static electricity because transistors and ICs may be easily damaged by it.
- Reassemble the unit, noting the kinds of screws, the soldering, and the arrangement of the leads. Refer to "Schematic Diagram" and exploded views for correct assembly.
- Reassemble in reverse order.

BOTTOM CABINET REMOVAL

1. Remove the battery cover and the batteries.
2. Remove five screws A holding the bottom cabinet and lift off the cover.

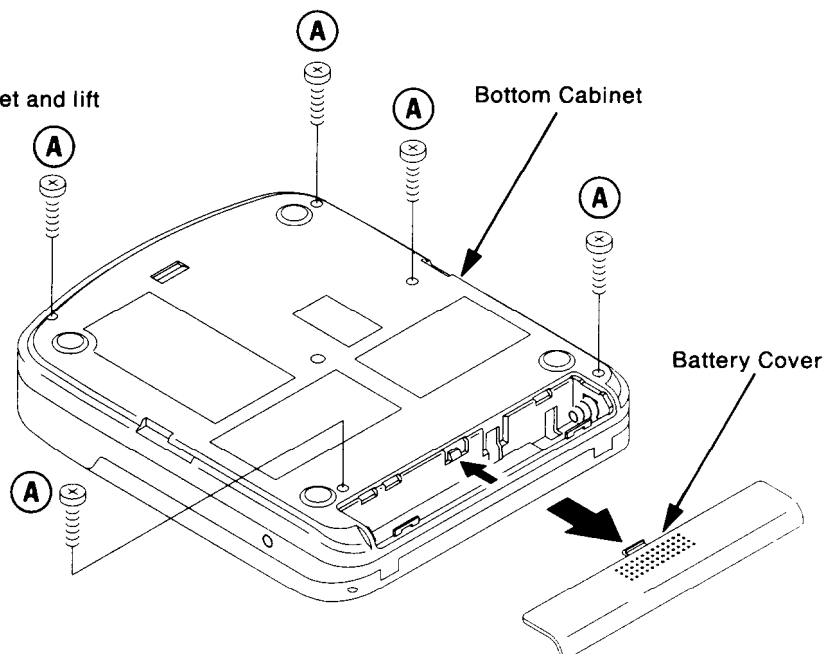

DISASSEMBLY INSTRUCTIONS (Continued)**TOP CABINET REMOVAL**

1. Remove the top cabinet.

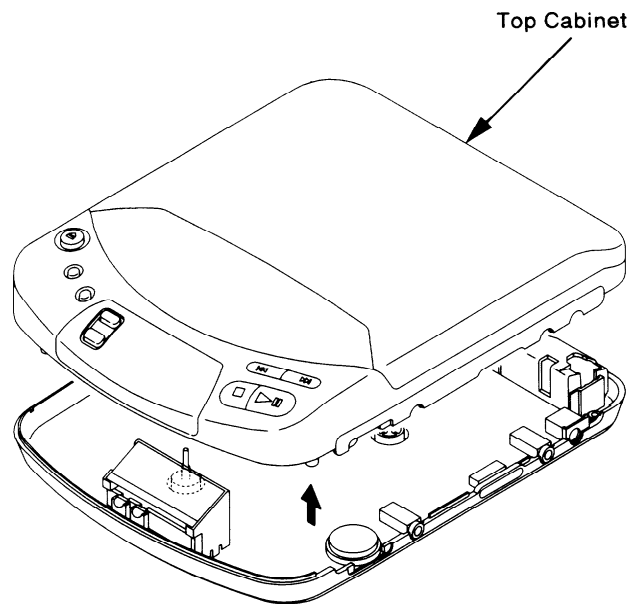
**CD MECHANISM REMOVAL**

1. Pull out the connectors CN1, CN2, and CN3 from the CD P.C.Board.
2. Gently remove the CD mechanism from the bottom cabinet.

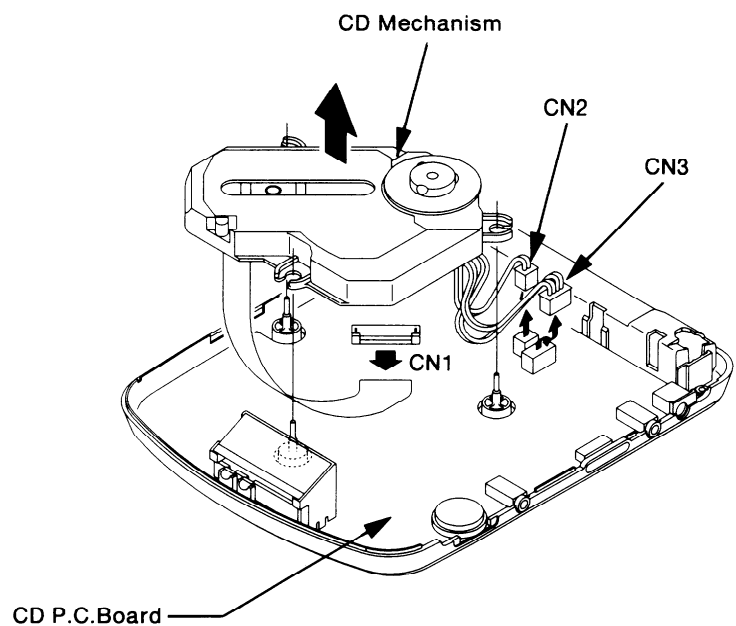

DISASSEMBLY INSTRUCTIONS (Continued)

CD MAIN P.C.BOARD REMOVAL

1. Remove the P.C.Board by lifting it in the direction shown by the arrow.

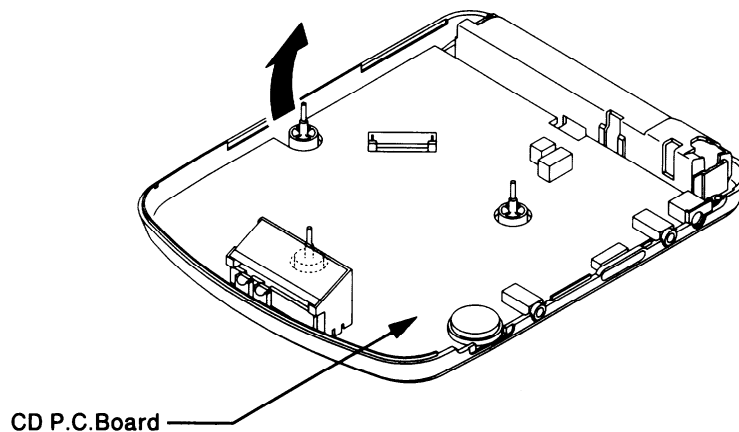

LASER PICKUP REPLACEMENT

Caution:

Laser diodes are extremely susceptible to damage from static electricity. Even if a static discharge does not ruin the diode, it can shorten its life or cause it to work improperly. When replacing the pickup, use a conductive mat and a grounded soldering iron to protect the laser diode from static damage.

1. Remove the CD mechanism assembly by referring to "Disassembly Instructions."
2. Remove screw B holding the slide shaft.
3. Gently remove the laser pickup and replace to new laser pickup.

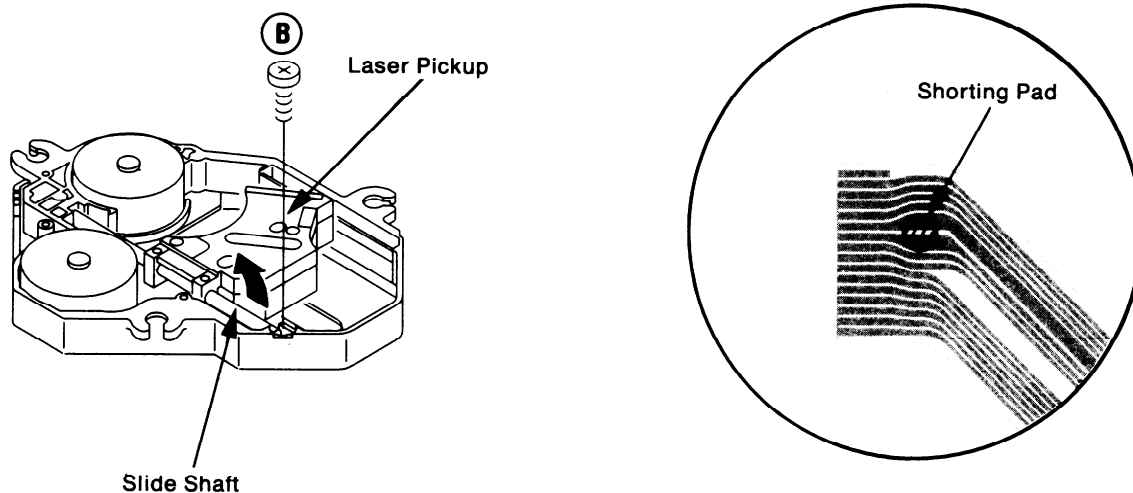

4. After you connect the wire connector, desolder and remove the shorting pad.

CABINET EXPLODED VIEW

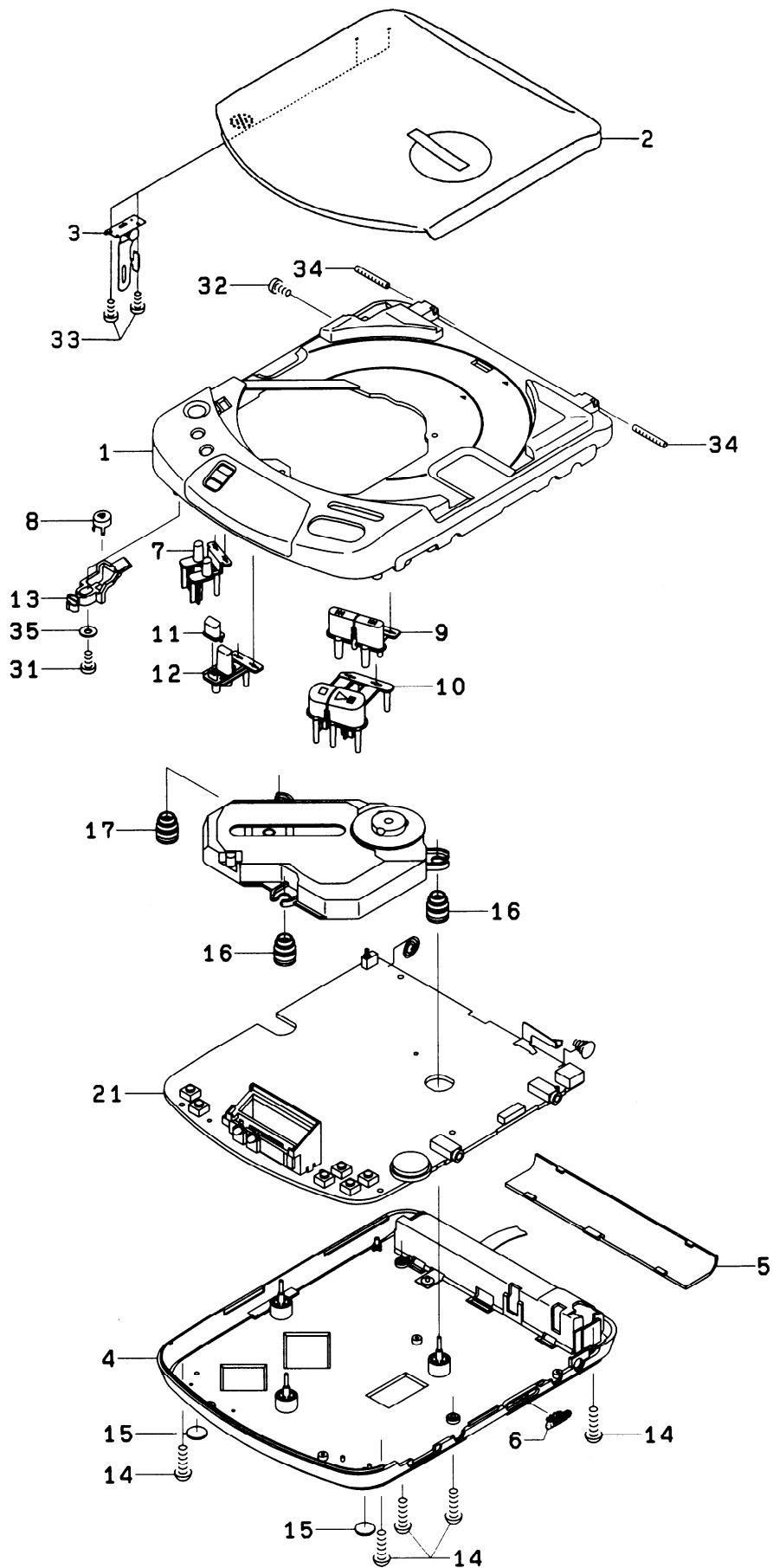

CABINET PARTS LIST

Ref. No.	Part No.	Description	Q'ty
	Package		
	6K21A23431	Inner Carton	1
	6K41A16900	Pad, Styrofoam	1
	6K42A12400	Pad, Plain	1
	6K301625B0	Poly Cover, 160 x 250	1
	Accessories		
	46629702000	NI-CD Pack NBP-30B	1
	4A30A01305	Headphone, 32, ONKYO	1
	⚠ 4U11A05600	Adaptor, AC-DC, 3CV-120CDT	1
	4W20A02201	Cord, Y, RCA.2P	1
	6P10A45839	Instruction Manual,U3	1
	29358002K	Service Station List	1
	29365019B	Card, Warranty	1
	Cabinet		
1	0111A17213	Assy, Cabinet, Top	1
2	0123A03400	Assy, Lid, Disc, CD	1
3	0322A02201	Assy, Bracket-M,Link	1
4	2112A08401	Cabinet, Bottom	1
5	2124A04202	Lid, Battery	1
6	2172A07205	Knob, Slide, Bass	1
7	2175A32500	Button, Mode/SET	1
8	2175A32600	Button, Eject	1
9	2175A32800	Button, FF/FB	1
10	2175A32900	Button, Play/Stop	1
11	2175A33001	Button, Light	1
12	2175A33101	Button, Antishock	1
13	2721A05100	Lever, Eject	1
14		Screw PAN HD. +M2.0 x 10.0	5
15		Foot Cushion	2
16	2443A08102	Cushion, Rubber	2
17	2443A08103	Cushion, Rubber	1
21	0B11A11202	Assy, PCB-W, CD	1
31	SFBDN206ROSE	SCR S-TPG BIN 2 X 6	1
32	SFXEA01300	SPECIAL SCREW	1
33	SGXE00101	SPECIAL SCREW	2
34	SPANN2018OUN	Pin SPRING 2 x 18	2
35		WASHER Y 2.1 x 7.5 x 0.5	1

NOTES:

- Parts order must contain Model Number, Part Number and Description.
- Ordering quantity of screws and resistors must be multiple of 10 pcs.

PRODUCT SAFETY NOTICE

Each precaution in this manual should be followed during servicing. Components identified with the IEC symbol ⚠ in the parts list and the schematic diagram designate components in which safety can be of special significance. When replacing a component identified with ⚠, use only the replacement parts designated, or parts with the same ratings of resistance, wattage or voltage that are designated in the parts list in this manual. Leakage-current or resistance measurements must be made to determine that exposed parts are acceptably insulated from the supply circuit before returning the product to the customer.

MECHANISM EXPLODED VIEW

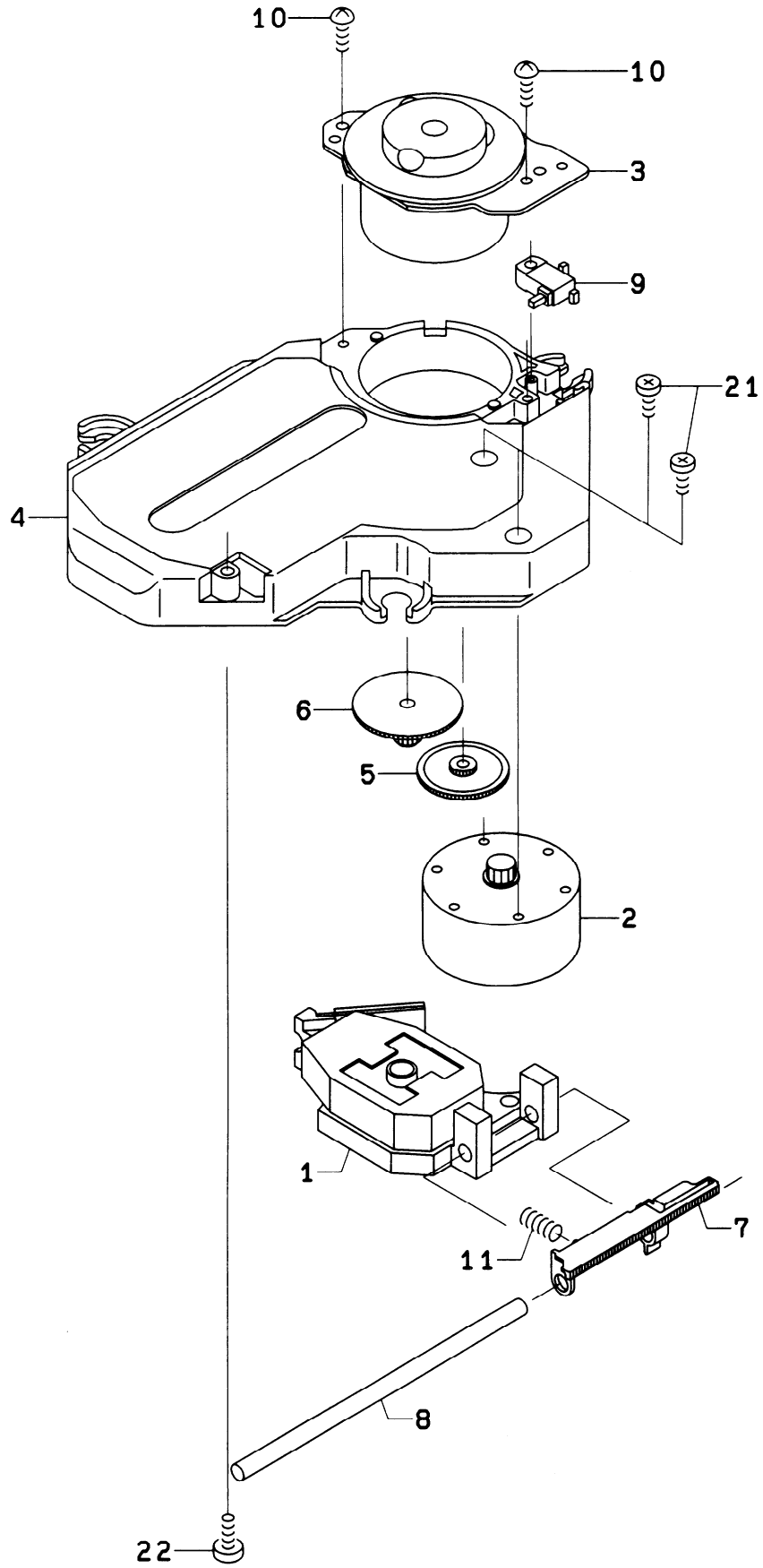

MECHANISM PARTS LIST

Ref. No.	Part No.	Description	Q'ty
MECHANISM			
	620 218 8744	Assy,Connector-S,4P	1
	620 214 0063	Label,Serial No.	1
1	620 218 3220	Pickup,Laser,SF-92	1
2	620 217 6734	Assy,Motor,Sled [M2]	1
3	620 217 6741	Assy,Motor,Spindle [M1]	1
4	620 217 6659	Chassis	1
5	620 217 6673	Gear,Middle	1
6	620 217 6680	Gear,Drive	1
7	620 217 6697	Gear,Rack	1
8	620 217 6710	Shaft,Slide	1
9	620 201 7266	Switch,Leaf (Limit Switch) [S8]	1
10	620 122 8793	Screw TPG PAN + M1.7X6.0	2
11	620 139 3361	Spring Supply	1
21	412 047 0309	SPECIAL SCREW	2
22	411 025 5107	SCR S-TPG BIN 2.6X8	1

NOTES:

1. Parts order must contain Model Number, Part Number and Description.
2. Ordering quantity of screws and resistors must be multiple of 10 pcs.

CD PLAYER ADJUSTMENT PROCEDURES

REQUIRED TOOLS

The following tools are required to make adjustments:

1. Frequency counter
2. Small flat-head screwdriver

SETTING OF INITIAL POSITION

Set the potentiometer to the initial positions listed below:

P502 PLL FREE RUN Mechanical Center

TEST MODE

To set the TEST mode, connect TP1 (TEST) to ground and switch on the power.

- **PLAY/PAUSE:** Focus and Tracking are switched on, and the play operation is engaged.
- **FFWD:** Sled motor moves in the direction of the outermost track.
- **FBACK:** Sled motor moves in the direction of the innermost track, then stops after the inner switch is turned on.
- **STOP:** All stop.
(Different from the stop mode)

PLL FREE RUN ADJUSTMENT

1. Connect a frequency counter between TP2 (PCK) and ground. (Use a 10:1 probe.)
2. To set the TEST mode, connect TP1 (TEST) to ground and switch on the power.
3. Connect TP3 (EFMIN) to ground, push the play button, and adjust Potentiometer P502 so that the frequency becomes $4.32\text{MHz} \pm 0.01\text{MHz}$.

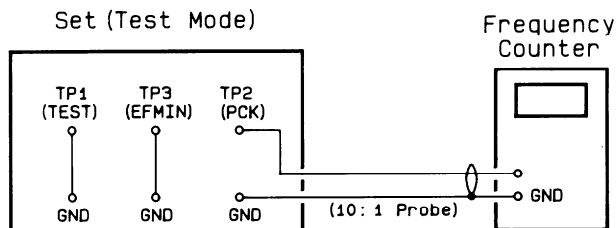

CD MAIN ADJUSTMENT POINTS

IC PIN FUNCTIONS

Pin Function of IC1 MB89655APF (Micro Computer)

PIN	SYMBOL	I/O	FUNCTION
1	Vcc	–	–
2	X1A	–	Resonator terminal (Clock)
3	X0A	–	Resonator terminal (Clock)
4	MOD0	–	Vss
5	MOD1	–	Vss
6	X0	–	Resonator terminal
7	X1	–	Resonator terminal
8	Vss	–	–
9	RSTX	I	Reset input terminal
10	P00/INT20	I	Test mode key
11	P01/INT21	I	FMT key
12	P02/INT22	I	Sound DSP key
13	P03/INT23	I	Sound EQ key
14	P04/INT24	I	Back Light Key
15	P05/INT25	I	RX IN
16	P06/INT26	O	Back Light ON/OFF output
17	P07/INT27	O	LD power ON/OFF output
18	P10/INT10	I	Key input (power ON interrupt)
19	P11/INT11	I	Pickup switch
20	P12/INT12	I	Lid switch
21	P13/INT13	I	System down
22	P14/INT28	O	Power ON (S/S1)
23	P15/INT29	I	Resume input
24	P16/INT2A	–	–
25	P17/INT2B	–	–
26	P20	O	RES (DSP)
27	P21	O	RWC (DSP)
28	P23	I	WRQ (DSP)
29	P24/S1	I	SQOUT (DSP)
30	P25/S0	O	COIN (DSP)
31	P26/SCK	O	CQCK (DSP)
32	P30 (SEG31)	O	EXRST (FMT)
33	P31 (SEG30)	I	EMPN (FMT)
34	P32 (SEG29)	O	PAUSE (FMT)
35	P33 (SEG28)	O	WOK (FMT)
36	P34 (SEG27)	O	SHOCK (FMT)
37	P35 (SEG26)	I	CNTOK (FMT)
38	P36 (SEG25)	I	OVF (FMT)
39	P37 (SEG24)	O	FMT (FMT)
40	P40 (SEG23)	O	RESET (DAC)
41	P41 (SEG22)	I	DRF (ASP)
42	P42 (SEG21)	O	Sound DSP/Sound EQ output
43	P43 (SEG20)	O	Sound DSP/Sound EQ output
44	P44 (SEG19)	O	Sound DSP output
45	P45 (SEG18)	O	2FREQ (ASP)
46	P46 (SEG17)	O	8/12 gain change
47	P47 (SEG16)	O	High speed/Normal speed VCO change
48	SEG15	–	LCD segment terminal
49	SEG14	–	LCD segment terminal
50	Vcc	–	–

IC PIN FUNCTIONS (Continued)

PIN	SYMBOL	I/O	FUNCTION
51	SEG13	–	LCD segment terminal
52	SEG12	–	LCD segment terminal
53	SEG11	–	LCD segment terminal
54	SEG10	–	LCD segment terminal
55	SEG09	–	LCD segment terminal
56	SEG08	–	LCD segment terminal
57	SEG07	–	LCD segment terminal
58	SEG06	–	LCD segment terminal
59	Vss	–	–
60	SEG05	–	LCD segment terminal
61	SEG04	–	LCD segment terminal
62	SEG03	–	LCD segment terminal
63	SEG02	–	LCD segment terminal
64	SEG01	–	LCD segment terminal
65	SEG00	–	LCD segment terminal
66	P82	I	Charge detection
67	P83	O	Charge resistor change
68	V3	–	LCD power terminal
69	V2	–	LCD power terminal
70	V1	–	LCD power terminal
71	V0	–	LCD power terminal
72	COM0	–	LCD common terminal
73	COM1	–	LCD common terminal
74	COM2	–	LCD common terminal
75	COM3	–	LCD common terminal
76	P50	–	F offset output
77	P51	O	SLS output
78	P52	–	T offset output
79	P53	–	DS
80	P54	–	EF gap adjustment output
81	P55	–	LD PWR output
82	P56	–	–
83	P57 (TO22)	O	Amp mute output
84	AVss (AVss)	–	–
85	P60 (AN00)	–	F offset input
86	P61 (AN01)	–	T offset input
87	P62 (AN02)	–	EF gap adjustment output
88	P63 (AN03)	–	LD PWR (H) input
89	P64 (AN04)	–	LD PWR (L) input
90	P65 (AN05)	–	Key input
91	P66 (AN06)	–	FMT rest display input
92	P67 (AN07)	–	Vref3 input
93	AVcc	–	–
94	AVR +	–	A/DC REF. terminal
95	P70 (EC1)	I	–
96	P71 (EC2)	O	FEEDOFF (ASP)
97	P72 (BUZ)	O	SL + (ASP)
98	P73	O	SL – (ASP)
99	P74	I	L Batt. detection input
100	P75	–	–

IC PIN FUNCTIONS (Continued)

Pin Function of IC501 LA9210 (Servo Signal Processor)

PIN	SYMBOL	FUNCTION
1	NC	No connection
2	VEE	Ground
3	E	Pickup E signal input
4	F	Pickup F signal input
5	FN	" - " terminal of pickup F signal
6	FO	E/F balance adjustment terminal
7	TEAO	Tracking error amplifier output
8	VREF2	Reference voltage
9	VREF3	Reference voltage
10	TES1	TE "S" curve input
11	ATSC	Anti-shock input
12	ATSC -	Anti-shock " - " input
13	TPA +	Tracking pre-amplifier " + " input
14	TPA -	Tracking pre-amplifier " - " input
15	TPAO	Tracking pre-amplifier output
16	TOFS	Tracking OFF switch
17	THDS	Tracking hold switch (Servo gain hold)
18	TD +	Add signal to tracking servo
19	JPO	Jump pulse adjustment
20	SLEQ	SLED equalizer
21	TDO	Tracking drive output
22	FDO	Focus drive output (Focus servo amplifier)
23	FD -	Focus drive " - " terminal (Focus servo amplifier)
24	FSW	Focus switch
25	NC	-
26	FEAO	Focus error amplifier output (Focus gain adjustment terminal)
27	FE -	Focus error amplifier " + " terminal
28	FD +	Focus drive amplifier " + " terminal
29	SPO	Spindle motor servo amplifier output
30	SPO -	Spindle drive amplifier " - " terminal
31	SPDO	Spindle drive amplifier output
32	VEE	Ground
33	SLDO	Sled motor servo drive output
34	SL -	Sled motor drive amplifier " - " input
35	SL +	Sled motor drive amplifier " + " input
36	VCC	Servo circuit power source
37	FEEDOF	H : Sled motor stop
38	DEFO	Defect output
39	2FREQ	H : Twice speed play
40	DRF	H : Focus OK
41	NC	-
42	JP -	Jump signal " - "
43	JP +	Jump signal " + "
44	THLD	H : Tracking servo output hold
45	TGL	H : Tracking gain down

IC PIN FUNCTIONS (Continued)

PIN	SYMBOL	FUNCTION
46	TOFF	H : Tracking servo off
47	TES	TE "S" curve output
48	HFL	Bottom hold out
49	FZD	Focus zero cross output
50	FOCS	H : Focus servo off
51	CLV -	CLV signal input (-)
52	CLV +	CLV signal input (+)
53	SLCO	Slice level control output
54	EFMO	Slice level control (negative-phase)
55	EFMO	Slice level control (in-phase)
56	VDD	Digital power source
57	PDO	Phase-comparison output of EFM signal and VCO/2
58	PDO -	PD amplifier "-" input
59	VCOC	PD amplifier output
60	VCOO	VCO output
61	LFI	Capacitor terminal of VCO low pass filter
62	CLK	VCO reference clock
63	LASER	L : APC circuit ON
64	60/65	-
65	NC	-
66	DF2	Capacitor of defect detection amplifier
67	DF1	
68	PH3	-
69	BH	HF signal bottom hold
70	PH	HF signal peek hold
71	GND	Ground
72	RFSM	RF sum amplifier output
73	RFS -	RF sum amplifier "-" terminal
74	LDD	APC circuit input terminal
75	LDS	Monitor diode input terminal
76	LDC	Laser diode change
77	VCC	Servo circuit power source
78	FIN1	A + C input
79	FIN2	B + D input
80	VREF	1/2 VCC output

IC PIN FUNCTIONS (Continued)

Pin Function of IC502 LB8106M (Focus Tracking Coil & Motor Driver)

PIN	SYMBOL	FUNCTION
1	IN1	Actuator control input FOCUS
2	IN2	Actuator control input TRACKING
3	Vout	4 channel H bridge power supply
4	VCD2	Output voltage of voltage up circuit
5	VCD1	Output voltage of voltage up circuit
6	DEFECT	GND
7	REF0	Sled drive reference voltage
8	IAI	Integrating AMP. input.
9	AO	No connection
10	IAO	No connection
11	OSC	Self oscillating circuit (CR input terminal)
12	OSC	Self oscillating circuit (CR power terminal)
13	UPB	NPN transistor drive output for voltage up
14	S/S1	Motive drive input for LB8106
15	S/S2	S/S1 and OR function
16	P GND	GND of power section
17	P GND	GND of power section
18	P GND	GND of power section
19	WP	Micom. motive output linked with S/S1
20	BO	No connection
21	BI	Detecting terminal of Battery voltage
22	DNB	PNP transistor output for voltage down.
23	GND	Signal GND
24	CLK	External clock input terminal
25	VCC	VCC
26	VREF2	Reference voltage 1.2V
27	SLH	Adjustment terminal of SLED drive start voltage
28	SLL	Adjustment terminal of SLED drive stop voltage
29	SLM	Sled switching terminal
30	VREF1	Reference voltage of motor control section input
31	Vout	4 channel H bridge power supply
32	IN3	Actuator control input (Spindle Motor)
33	IN4	Actuator control input (Sled Motor)
34	OUT4 -	Actuator drive output (-) SLED
35	OUT4 +	Actuator drive output (+) SLED
36	OUT3 -	Actuator drive output (-) SPINDLE
37	OUT3 +	Actuator drive output (+) SPINDLE
38	P GND	GND of power section
39	P GND	GND of power section
40	P GND	GND of power section
41	OUT2 -	Actuator drive output (-) TRACKING
42	OUT2 +	Actuator drive output (+) TRACKING
43	OUT1 -	Actuator drive output (-) FOCUS
44	OUT1 +	Actuator drive output (+) FOCUS

IC PIN FUNCTIONS (Continued)

Pin Function of IC601 LC78681E-L (DSP)

PIN	SYMBOL	I/O	FUNCTION
1	TEST1	I	LSI test pin; normally not connected.
2	AO	O	The VCO output built into the LA9210 is input to this pin. PDO (8.6436 MHz) outputs the EFM signal and the phase output; it is set so that the frequency is raised with a "+".
3	AI	I	
4	PDO	O	
5	Vss	-	Ground
6	$\overline{\text{EFMO}}$	O	An HF signal of 1 to 2 Vp-p is input to EFMIN. EFM signals of mutually opposite phase which have passed through the amplitude limiter following EFMO and $\overline{\text{EFMO}}$ are output. This allows slice level control to be performed.
7	EFMO	O	
8	EFMIN	I	
9	TEST2	I	LSI test pin; normally not connected.
10	CLV+	O	Output for disc motor control.
11	CLV-	O	
12	V/P	O	"H" output at time of the CLV rough servo operation, "L" output at the time of phase control.
13	FOCS	O	The focus servo is switched off when FOCS is "H". The lens is lowered with FST and is gradually raised with FOCS at "H". FOCS is reset when FZD is produced. These pins are used for focus retraction.
14	FST	O	
15	$\overline{\text{FZD}}$	I	
16	HFL	I	Produces the kick pulse, JP+, and JP- corresponding to the track jump command. Performs jumps of the prescribed number of tracks (1, 2, 4, 16, 32, 64, and 128).
17	TES	I	
20	TOFF	O	
21	TGL	O	
22	THLD	O	
25	JP+	O	
26	JP-	O	
18	PCK	O	4.3218 MHz PCK monitor pin.
19	FSEQ	O	"H" is produced with the agreement of SYNC (true FS) detected from the EFM signal and SYNC (built in FS) of the counter. (Latch output between frames.)
23	TEST3	I	LSI test pin; normally not connected.
24	Vdd	-	+5 V
27	DEMO	I	Used for the adjustment procedure of the set; sound output function.
28	TEST4	I	LSI test pin; normally not connected.
29	EMPH	O	De-emphasis is required at time of "H".
30	NC	-	No connection.
31	WCLK	O	Signal output to DAC, latch signal and L/R switching, and signal used for sample hold.
33	LRCLK	O	
35	DFOUT	O	
36	DACLK	O	
32	TEST7	O	LSI test pin; normally not connected.
34	NC	-	No connection.
37	TEST6	O	LSI test pin; normally not connected.
38	LRSY	O	Used for signal output corresponding to the CDROM.
39	CK2	O	
40	ROMOUT	O	
41	C2FCLK	O	
42	C2F	O	
43	DOUT	O	Digital OUT output.

IC PIN FUNCTIONS (Continued)

PIN	SYMBOL	I/O	FUNCTION
44	SBSY	O	Sync signal of the sub code block.
45	EFLG	O	Used for the correction monitor of C1, C2, 1 multiplex, and 2 multiplex.
46	PW	O	SFSY is the sync signal of the sub code frame. The sub codes of P, Q, R, S, T, U, V, W are read by sending the clock to SBCK 8 times.
47	SFSY	O	
48	SBCK	I	
49	FSX	O	
50	WRQ	O	WRQ becomes "H" when the data of sub code Q has passed the CRC check. This is taken externally and by sending CQCK, the data is read from SQOUT. When the data is desired with the LSB first, M/L is dropped to "L". After RWC is set to "H" by the microprocessor, it is synchronized with the CQCK command data and sent to give the command.
51	RWC	I	
52	SQOUT	O	
53	COIN	I	
54	CQCK	I	
56	M/L	I	
55	RES	I	This is set once to "L" when the power is switched on.
57	LASER	O	This output pin can be controlled by serial control from the microprocessor.
60	CONT	O	
58	16M	O	16.9344 MHz output pin.
59	4.2M	O	4.2336 MHz output pin.
61	TEST5	I	LSI test pin; normally not connected.
62	CS	I	Chip select pin. The LC78681 becomes active when this pin is "L".
63	XIN	I	Connection pins of the 16.9344 MHz crystal oscillator.
63	XOUT	O	

IC PIN FUNCTIONS (Continued)



Pin Function of IC602 LC92080A-854 (Anti Shock)

PIN	SYMBOL	I/O	FUNCTION
1	FMT	I	Anti Shock play/Normal play change terminal
2	MR1	I	1M/4M DRAM change terminal
4	X2FIX	I	Clock change terminal (H : internal L : use external 16M)
5	REPEAT	O	Memory empty out (This pins reset the gate array)
6	MMC0	O	Display signal that the rest of memory output terminal
7	MMC1	O	
8	MMC2	O	
9	MMC3	O	
12	OVF	O	Memory write interrupt signal output (Memory over flow and shock)
13	CNTOK	O	Memory write starting signal output
14	EXRST	I	External reset signal input (L active)
15	WOK	I	Memory write permission signal
16	PAUSE	I	Pause signal input (H : PAUSE)
17	Vss	—	GND
18	DACLKIN	I	DAC bit clock signal input from DSP (LC78681)
19	LRCLK	I	LR clock signal input from DSP (LC78681)
20	DFOUT	I	DAC data signal input from DSP (LC78681)
21	C2FIN	I	C2F signal input from DSP (LC7861)
23	NGJ	O	Access starting signal of C2F
24	Vdd	—	+ 4.0V
25	TOUT	O	Test signal output
28	EX16M	I	External 16M clock input
31	EXPN	O	The rest of memory alarm output (L : empty)
32	SHOCK	I	Anti shock enable terminal (H : Anti shock ON)
33	DRAM3	—	DRAM data line (TTL level)
34	DRAM2	—	DRAM data line (TTL level)
35	DRAM1	—	DRAM data line (TTL level)
36	DRAM0	—	DRAM data line (TTL level)
37	OEN	O	DRAM control line
38	WEN	O	DRAM control line
39	CAS	O	DRAM control line
40	RAS	O	DRAM control line
44	AD9	O	DRAM address line
56	Vdd	—	+ 4.0V
61	TESGB	I	Test mode change terminal (H : Normal mode)
62	DACOUT	O	DAC data signal output
63	DACLR	O	DAC LR signal output
64	DACCLK	O	DAC clock signal output

P.C.BOARD PARTS LIST

Ref. No.	Part No.	Description	Ref. No.	Part No.	Description
	LCD			Diodes	
LCD1	6202183558	LD-B5599JZ	D1	4071258209 or 4070080405	HSS271 or GMB01-BT
	ICs		D301,302	4071614104	SLR-33VR3F
IC1	4101741701	MB89655APF-G-112-BND	D303	223168	DA210S
IC301	4091256100	LA3550M-TP-T1	D401-403	4070804209	SB10-03A3-BT
IC302	4090816909	LA4533M-TP-T1	D404-406	225142	SEL2913K
IC401	4090184008	LA6393M-TP-T1	D501-504	4071258209 or 4070080405	HSS271 or GMB01-BT
IC402	4092454802	LA9210M	D505	4070804209	SB10-03A3-BT
IC502	4092263008	LB8106M		Resonator	
IC601	4093029702	LC78681E-L	CR1	6202022062	4.19MHz
IC603	4101741800 or 4101741602	MB81C4256A-80PJ-G-LV or MSM514256BJ-10JS-FS		Jacks	
IC604	4092845808	SM5871AS-ET	J301,302	6201871333	Jack 3P (LINE OUT,HEADPHONE)
IC605	22240608R	NJM2100	J401	6200203296	EXT Power Socket
	Transistors			Switches	
Q1	4050037207 or 2214060R0	2SA1342-TA or DTA124EK	S1-S7,S10	6202188249	L=4.3,100G,TP,Tact Switch
Q2,Q3	2214760R0	DTC114TK	S9	6200168960	1P2T,Detector Switch (LID OPEN)
Q4	4050370809 or 221281	2SC4048-AC or DTC114YS	S11	6202149141	0.8,Tact Switch (RESET)
Q101,102, 201,202	2213895	DTC343TS	S301	6200168717	2P3T,Slide Switch (E.E.S)
Q301	4050087103	2SB808-G-SPA-AC		Resistors	
Q302	2213090	DTA114YS	P502	6202185101	Semi 100K-B,Variable
Q303	4050370809 or 221281	2SC4048-AC or DTC114YS		6202189505	Semi 100K-B,Variable
Q304	4050452703 or 4050003608	2SC4047-TA or DTC114YK-T97	VR301	6200060790	2X10KA,Rotary Variable
Q401	4050370809 or 221281	2SC4048-AC or DTC114YS		Crystal	
Q402	4050087103	2SB808-G-SPA-AC	X601	6200073288	16.9344MHz
Q403	4051176509	2SD2171S-V-TP		Capacitors	
Q404	4050370809 or 221281	2SC4048-AC or DTC114YS	C407	4030933703	10μF/6.3V,OS-SOLID
Q405	4050087103	2SB808-G-SPA-AC	C408,409	4031937601	220μF/6.3V,Elect.
Q406	4050000904	DTA114YS-TP	C411	4030935103	33μF/6.3V,OS-SOLID
Q407	2213090	DTA114YS		Inductor	
Q501	4050087103	2SC4047-TA	L402	6202182735	22μH,Ferrite
Q503	4050452703 or 4050003608	2SC4047-TA or DTC114YK-T97			
Q504	4050293207	DTC114TK-T97			
Q505	4050639807	DTC114YL-TL2			
Q506	4050087103	2SB808-G-SPA-AC			
Q508	4050293207	DTC114TK-T97			
Q509	4050037207 or 2214060R0	2SA1342-TA or DTA124EK			
Q601	4050452703 or 4050003608	2SC4047-TA or DTC114YK-T97			

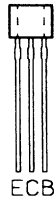
IC & TRANSISTOR LEAD IDENTIFICATION

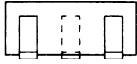
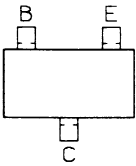
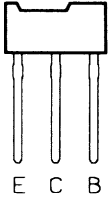
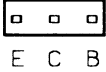
TRANSISTOR	FRONT VIEW	BOTTOM VIEW	TRANSISTOR	FRONT VIEW	BOTTOM VIEW
DTA114 DTC343TS 2SB808 2SC4048			DTC114 2SA1342 2SC4047		
DTC114YL 2SD2171S					
TERMINAL NAME					
B → BASE C → COLLECTOR E → EMITTER					

LA6393M-TP-T1 TOP/SIDE VIEWS
NJM2100M-TE3 TOP/SIDE VIEWS

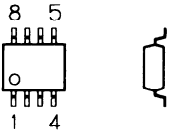

LA3550M-TP-T1 TOP/SIDE VIEWS

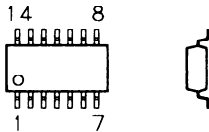

LA4533M-TP-T1 TOP/SIDE VIEWS

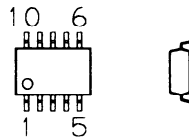

SM5871AS-ET TOP/SIDE VIEWS

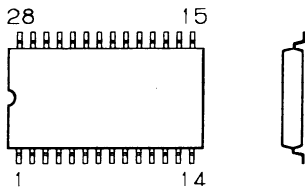

LC78681E-L TOP/SIDE VIEWS
LC92080A-854 TOP/SIDE VIEWS

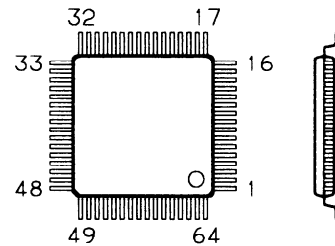

LA9210 TOP/SIDE VIEWS

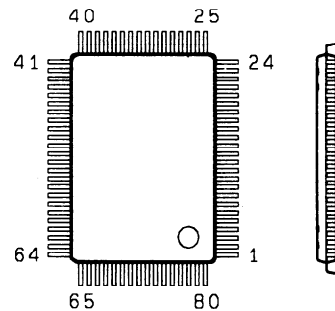

LB8106M TOP/SIDE VIEWS

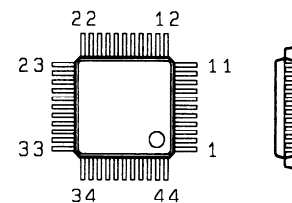

IC & TRANSISTOR LEAD IDENTIFICATION (Continued)

MB81C4256A-80PJ-G-LV TOP/SIDE VIEWS

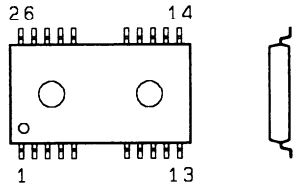

MB89655APF-G-112-BND TOP/SIDE VIEWS

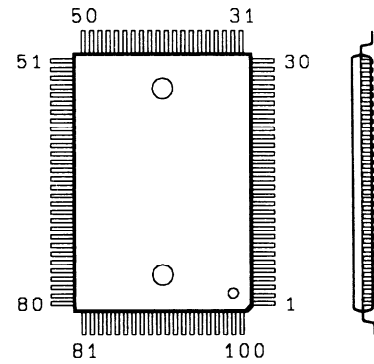

IC BLOCK DIAGRAM

IC401,IC402 LA6393M-TP-T1 BLOCK DIAGRAM (Comparator)

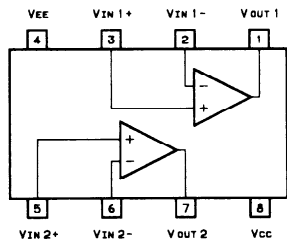

IC301 LA3550M-TP-T1 BLOCK DIAGRAM (Electronic Equalization)

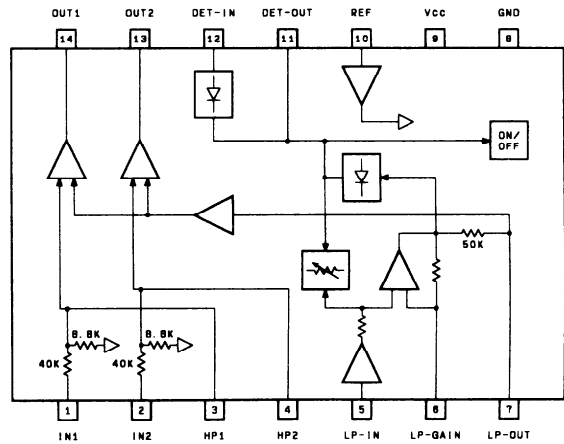

IC605 NJM2100M-TE3 BLOCK DIAGRAM (Difference Amplifier)

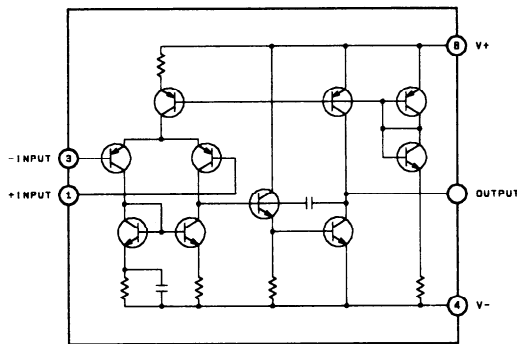

IC302 LA4533M-TP-T1 BLOCK DIAGRAM (Headphone Amp.)

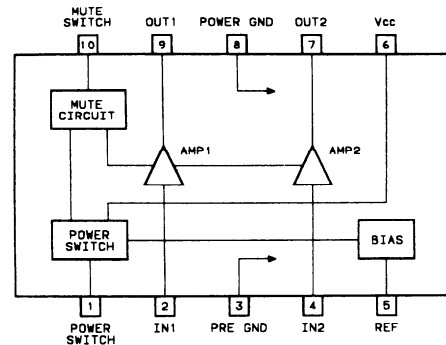

IC BLOCK DIAGRAM (Continued)

**IC604 SM5871AS-ET BLOCK DIAGRAM
(D/A Converter)**

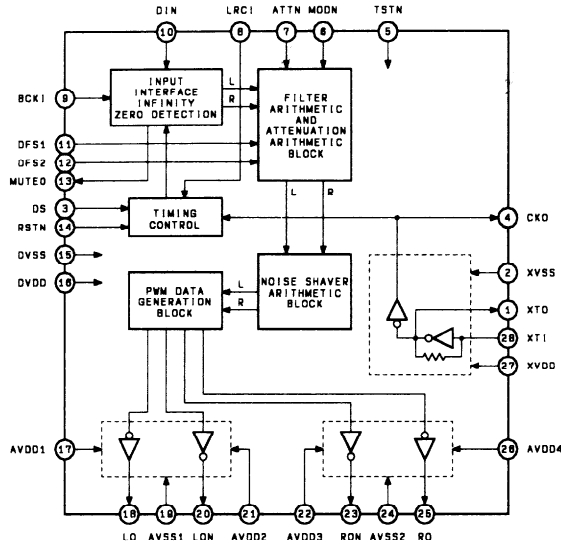

**IC601 LC78681E-L BLOCK DIAGRAM
(DSP)**

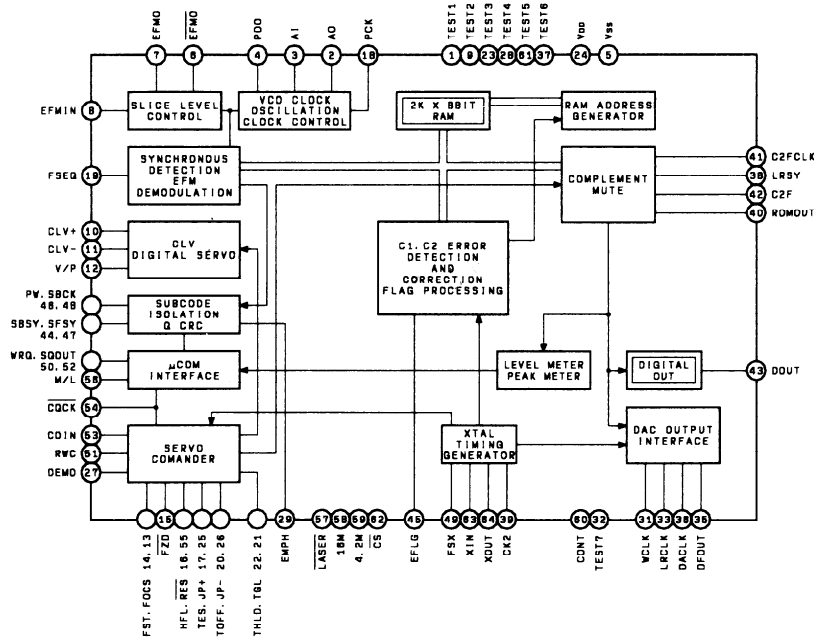

IC BLOCK DIAGRAM (Continued)

**IC602 LC92080A-854 BLOCK DIAGRAM
(Anti-Shock)**

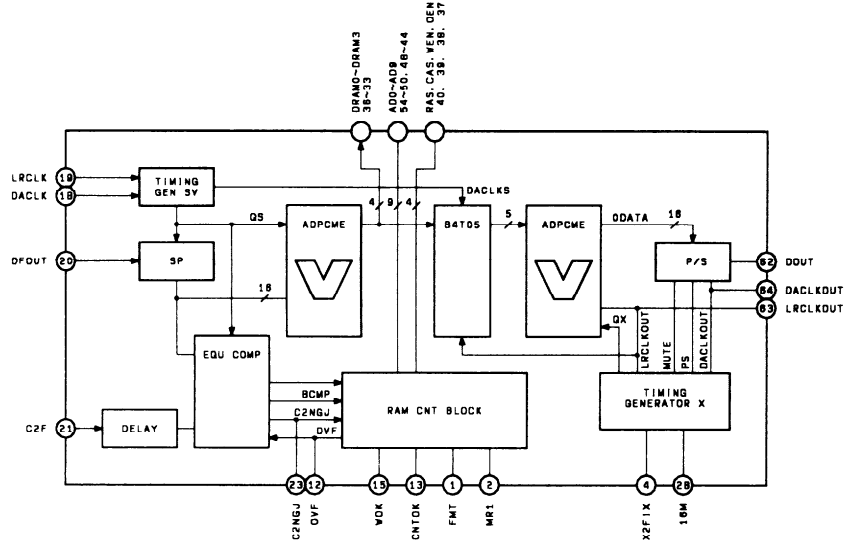

**IC501 LA9210 BLOCK DIAGRAM
(Servo Signal Processor)**

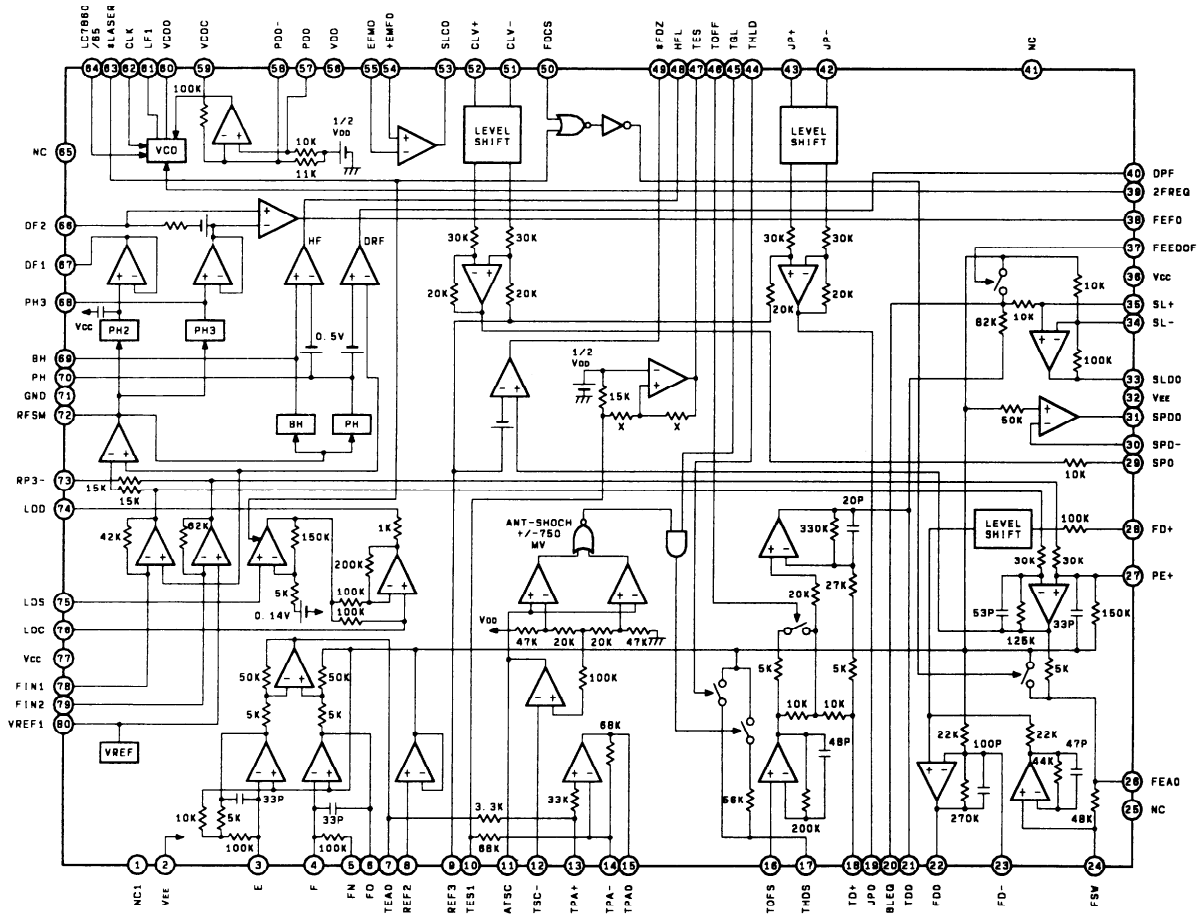

IC BLOCK DIAGRAM (Continued)

**IC502 LB8106M BLOCK DIAGRAM
(Focus Tracking Motor Driver)**

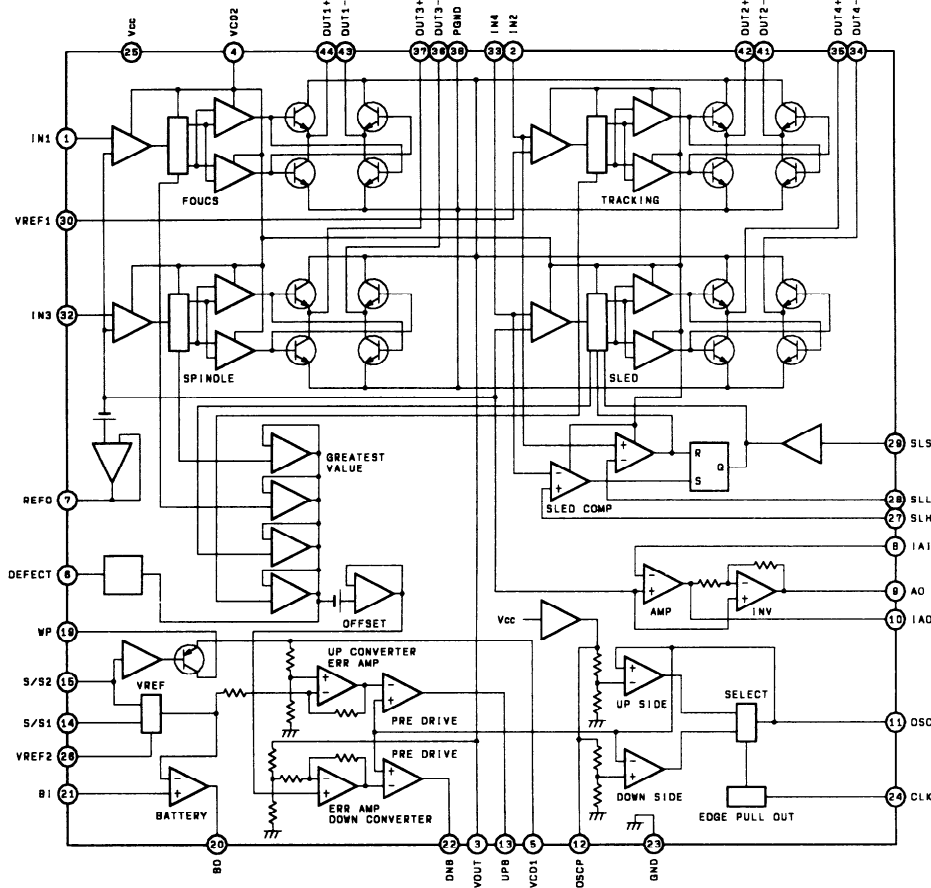

**IC603 MB81C4256A-80PJ-G-LV BLOCK DIAGRAM
(1M-DRAM)**

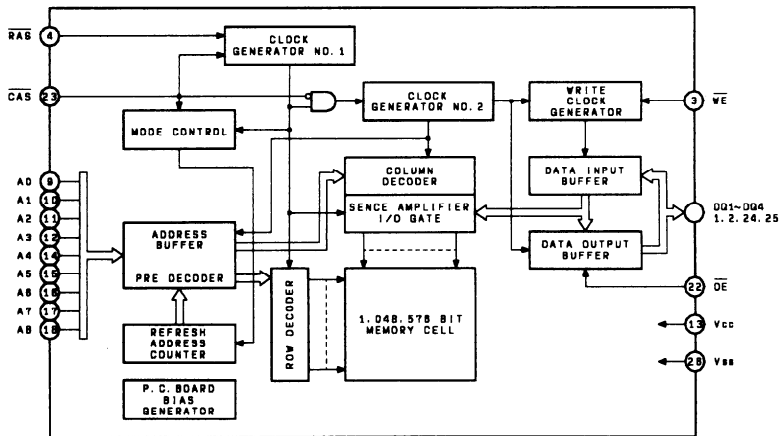

PACKING VIEW

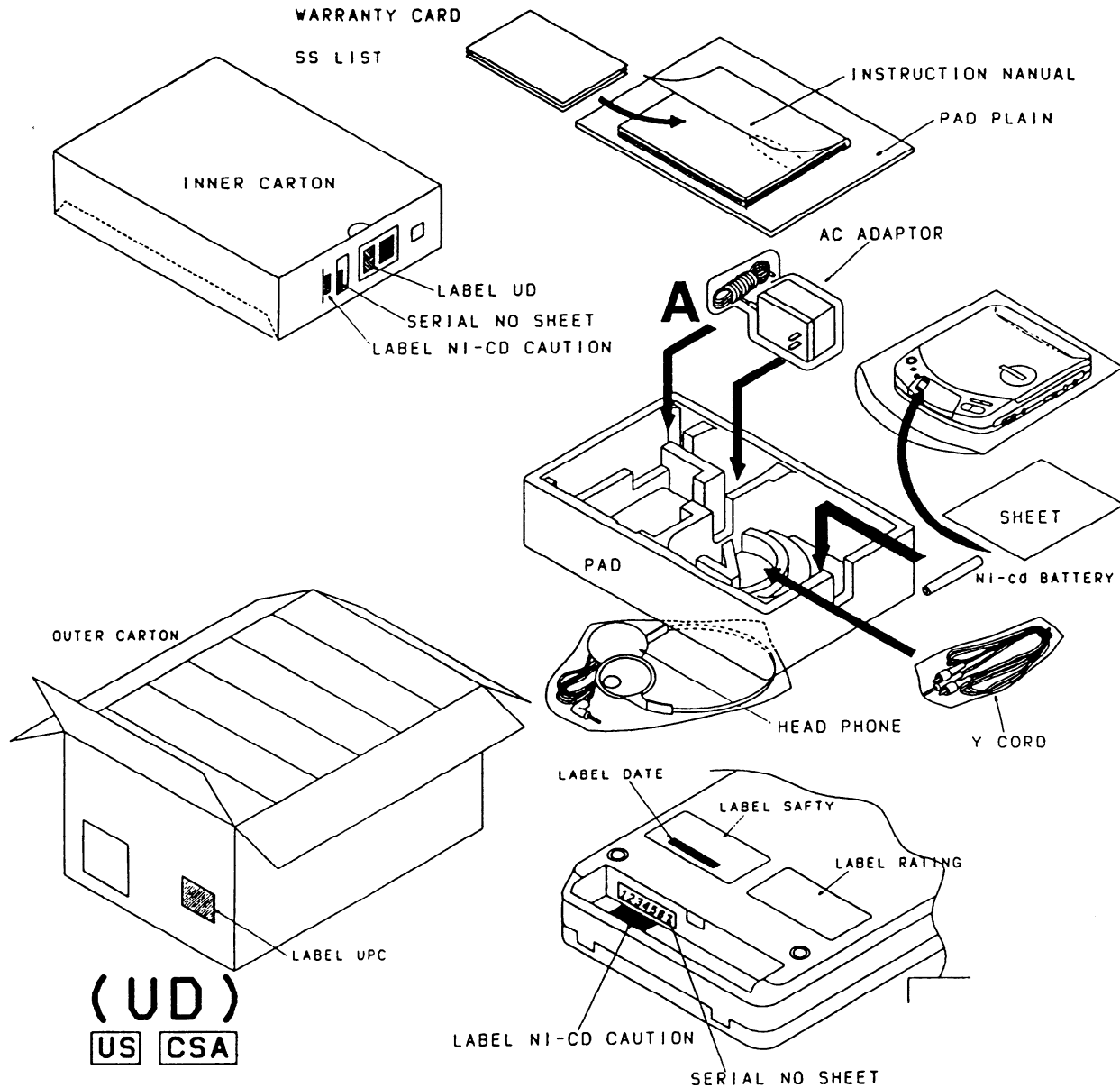

ONKYO CORPORATION

Sales Planning & Promotion Dept. : 2-1, Nisshin-cho, Neyagawa-shi, OSAKA 572, JAPAN

Tel: 0720-31-8111 Fax: 0720-33-5222

ONKYO U.S.A CORPORATION

200 Williams Drive, Ramsey, N.J. 07446, U.S.A.

Tel: 201-825-7950 Fax: 201-825-8150

ONKYO DEUTSCHLAND GMBH ELECTRONICS

Industriestrasse 18-20, 82110 Germering, GERMANY

Tel: 089 84 20 Fax: 089 84 93 226

ONKYO FRANCE

Immeuble Le Diamant, Domaine Technologique de Saclay, 4 Rue Rene Razel,

91892 SACLAY, FRANCE Tel: (1) 69 33 1400 Fax: (1) 69 41 35 84

CD PRINTED CIRCUIT BOARD (TOP VIEW)

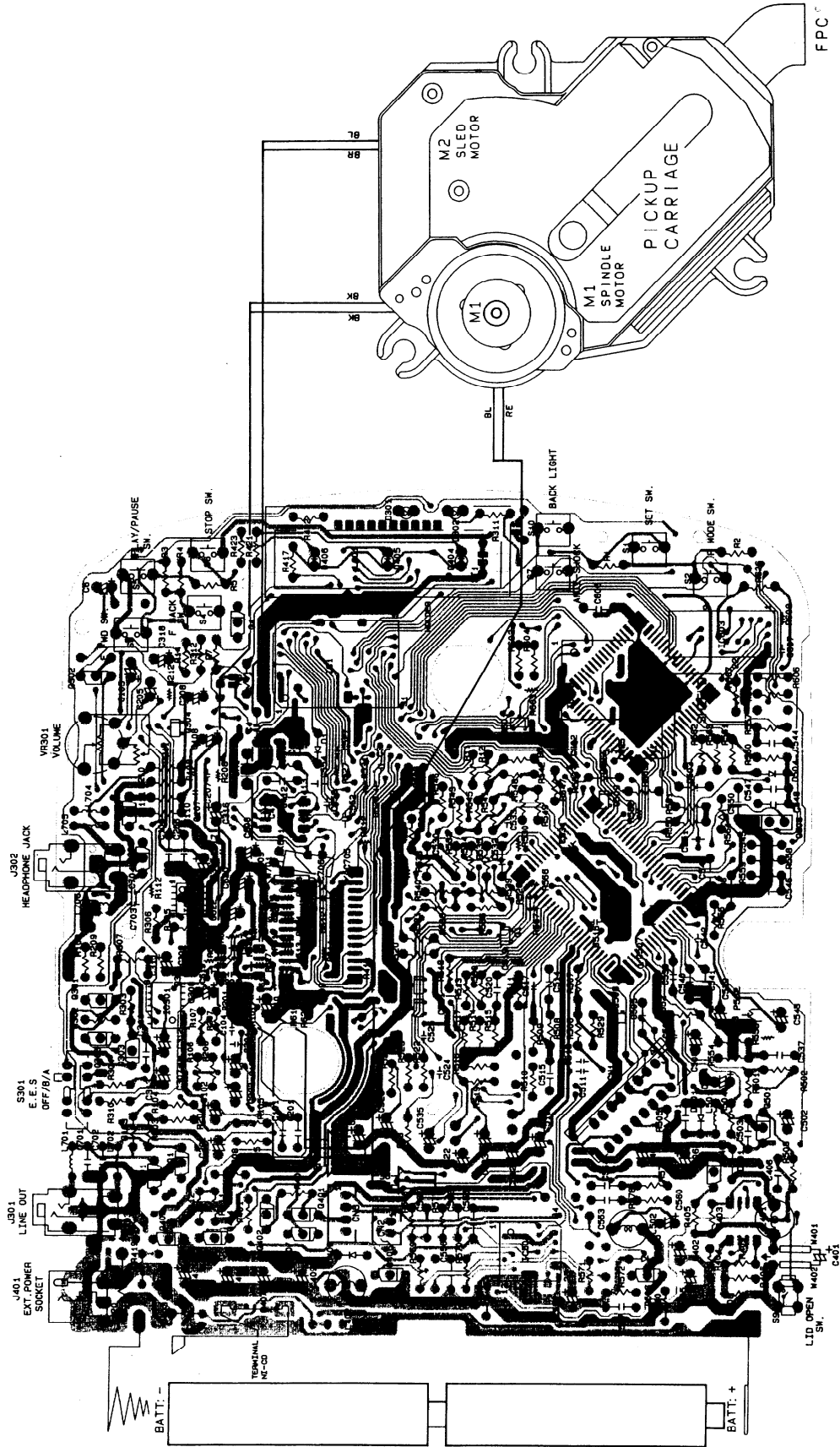

A

B

C

D

E

F

G

SCHEMATIC DIAGRAM PART 1

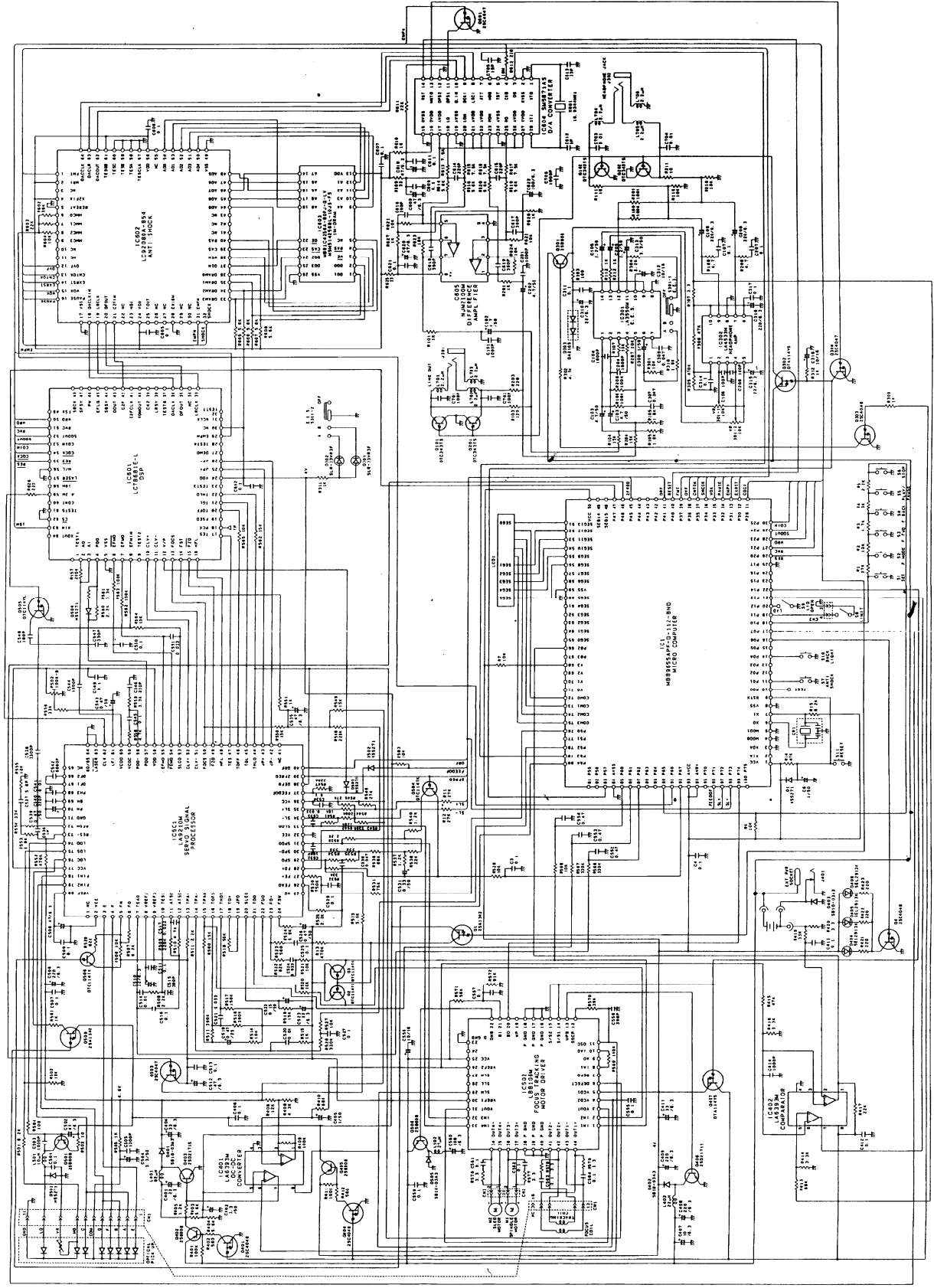

1

2

3

4

5