

# ONKYO® SERVICE MANUAL

## OPTICAL AV DISC PLAYER MODEL DX-V801

### SAFETY-RELATED COMPONENT WARNING!!

COMPONENTS IDENTIFIED BY MARK  ON THE SCHEMATIC DIAGRAM AND IN THE PARTS LIST ARE CRITICAL FOR RISK OF FIRE AND ELECTRIC SHOCK. REPLACE THESE COMPONENTS WITH ONKYO PARTS WHOSE PART NUMBERS APPEAR AS SHOWN IN THIS MANUAL.

MAKE LEAKAGE-CURRENT OR RESISTANCE MEASUREMENTS TO DETERMINE THAT EXPOSED PARTS ARE ACCEPTABLY INSULATED FROM THE SUPPLY CIRCUIT BEFORE RETURNING THE APPLIANCE TO THE CUSTOMER.

### TABLE OF CONTENTS

Safety information.....	2
Specifications.....	2
Exploded views and parts list.....	4
Exterior section.....	4
Front panel section.....	7
Clamper section.....	10
Base section.....	13
Loading section.....	14
Mechanism assembly.....	17
Carriage assembly.....	20
Packing.....	23
P.C. boards location.....	24
Schematic and pc boards diagram.....	25
Overall wiring diagram.....	25
LSFB,TRSF,TRSS,SYPS assemblies.....	27
PREB,PRET,FGSB,CNNB,PICKUP assemblies.....	33
Main assembly.....	39
Audio assembly.....	53
FLK1,FLK2 assemblies.....	61
P.C. boards-parts list.....	67
Disassembly.....	71
Test mode.....	77
Adjustment.....	81

**ONKYO**  
**AUDIO COMPONENTS**

# 1. SAFETY INFORMATION

## 1. SAFETY PRECAUTIONS

The following check should be performed for the continued protection of the customer and service technician.

### LEAKAGE CURRENT CHECK

Measure leakage current to a known earth ground (water pipe, conduit, etc.) by connecting a leakage current tester such as Simpson Model 229-2 or equivalent between the earth ground and all exposed metal parts of the appliance (input/output terminals, screwheads, metal overlays, control shaft, etc.). Plug the AC line cord of the appliance directly into a 120V AC 60Hz outlet and turn the AC power switch on. Any current measured must not exceed 0.5mA.

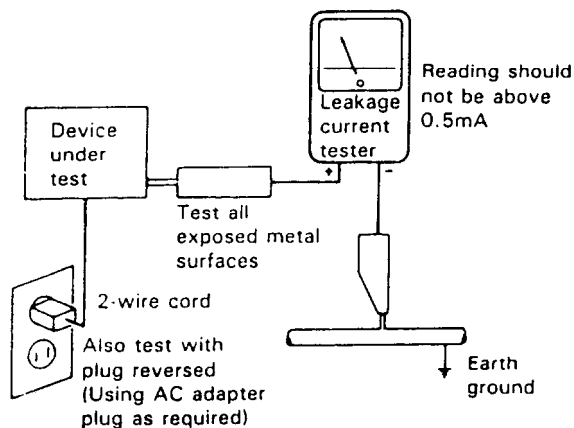

AC Leakage Test

ANY MEASUREMENTS NOT WITHIN THE LIMITS OUTLINED ABOVE ARE INDICATIVE OF A POTENTIAL SHOCK HAZARD AND MUST BE CORRECTED BEFORE RETURNING THE APPLIANCE TO THE CUSTOMER.

## 2. PROTECTION OF EYES FROM LASER BEAM DURING SERVICING

This set employs a laser. Therefore, be sure to follow carefully the instructions below when servicing.

### WARNING!!

WHEN SERVICING, DO NOT APPROACH THE LASER EXIT WITH THE EYE TOO CLOSELY. IN CASE IT IS NECESSARY TO CONFIRM LASER BEAM EMISSION, BE SURE TO OBSERVE FROM A DISTANCE OF MORE THAN 30cm FROM THE SURFACE OF THE OBJECTIVE LENS ON THE OPTICAL PICK-UP BLOCK.

# 2. SPECIFICATIONS

### Video characteristics

Format	: NTSC specifications
Output level	: 1Vp-p nominal, sync. negative, terminated
Signal to noise ratio	: 49dB
Horizontal resolution	: 425 Lines

### Digital Audio characteristics

Number of channels	: 2 (stereo)
Output level	: 2Vrms (1kHz 0dB)
Frequency response	: 4Hz~20kHz ( $\pm 0.5$ dB)
Total harmonic distortion	: 0.003%
Dynamic range	: 98dB
Signal to noise ratio	: 107dB
Channel separation	: 99dB
Wow and flutter	: Below threshold of measurability

### General

Power supply rating	: AC 120V 60Hz
Power consumption	: 37W
Dimensions (W×H×D)	: 455×132×442mm 17-15/16"×5-3/16"×17-5/16"
Weight	: 10.9kg (24lbs)

### Supplied accessories

- Audio cord
- Video cord
- Remote control transmitter (RC-226C)
- UM-4/R03/AAA dry cell batteries

Specifications and external appearance are subject to change without notice because of product improvements.

**Functions**

	Function	Standard play Disc (CAV)	Extended play Disc (CLV)	Compact Disc with Video	Compact Disc
Basic Functions	Two-side play	YES	YES	NO	NO
	Single-side play	YES	YES	YES	YES
	Pause	YES	YES	YES	YES
	Stop	YES	YES	YES	YES
Search	Fast forward (forward and reverse)	YES	YES	YES	YES
	Chapter/Track skip	YES	YES	YES	YES
	Direct chapter/Track number search	YES	YES	YES	YES
	Frame number search	YES	NO	NO	NO
	Time number search	NO	YES	YES	YES
	Absolute time search	NO	NO	NO	YES
Program	Chapter/Track program play	YES	YES	YES	YES
	Program correction	YES	YES	YES	YES
Repeat (player only)	Repeat between 2 points	YES	YES	YES	YES
	Memory repeat	YES	YES	YES	YES
	Chapter/Track repeat	YES	YES	YES	YES
	One-side repeat	YES	YES	YES	YES
	Two-side repeat	YES	YES	NO	NO
	Program repeat	YES	YES	YES	YES
	Random repeat	YES <sup>1</sup>	YES <sup>1</sup>	YES	YES
Program random repeat	YES	YES	YES	YES	
Trick play	Still/Step	YES	NO	NO	NO
	Multi-Speed (Forward/Reverse 9-Level Variable)	YES	NO	NO	NO
Time display	Elapsed time display	NO	YES	YES	YES
	Absolute time display	YES <sup>1</sup>	NO	NO	YES
	Remaining track time display	NO	NO	YES <sup>4</sup>	YES
	Remaining total time display	YES <sup>1</sup>	YES <sup>1</sup>	YES	YES
	Total number of selections, Total time display	YES <sup>1</sup>	YES <sup>1</sup>	YES	YES
Others	CX system ON/OFF	YES <sup>2</sup>	YES <sup>2</sup>	-	-
	AUTO DIGITAL/ANALOG switch	YES <sup>3</sup>	YES <sup>3</sup>	-	-
	Audio channel selection (Stereo, 1/L, 2/R)	YES	YES	YES	YES

Player function	Intro scan	YES	YES	YES	YES
	Random playback	YES <sup>1</sup>	YES <sup>1</sup>	YES	YES
	Program random playback	YES	YES	YES	YES
	Auto program/compu program edit	YES <sup>1</sup>	YES <sup>1</sup>	YES	YES
	Digital Sound for Laser Vision Discs	YES	YES	-	-
	DISPLAY	YES			
	Visual Calender Display	YES			
	Last Memory	YES		NO	

\*1 Only discs with TOC

\*2 Valid for analog sound playing a disc with the  mark.

\*3 Can only be used with discs with digital sound tracks.

\*4 Audio part only

**NOTE:**

The specifications and design of this product are subject to change without notice, due to improvement.

### 3. EXPLODED VIEWS AND PARTS LIST

#### NOTES:

- Parts without part number cannot be supplied.
- The components identified by mark  $\Delta$  are critical for risk of fire and electric shock.  
Replace only with part number specified.

#### 3.1 EXTERIOR SECTION

##### Parts List of Exterior Section

Ref.No.	Part No.	Description
1	27262552	Carry rubber
2	28141172	Rubber sheet D
3	28141173	Rubber sheet C
4	28141125	Disc pad L
5	28141126	Disc pad S
6	27301509	Stopper rubber
8	838430068	3TTB+6B(BC),Self-tapping screw
9	838130140	3TTB+14P,Self-tapping screw
10	834430068	3TTS+6B(BC),Self-tapping screw
11	837130069	3TTT+6C,Self-tapping screw
12	27301589	Tray ass'y
21	28184516	Bonnet
22	27301587	Side panel L
23	27301588	Side panel R
24	801488	Special screw
25	801487	Special screw
26	27301532	Plate
103		Cushion
104	28141176	Cushion
105	28175195	Insulator sheet
107	29361418	Label, tray
108	27301590	Carry assembly

## Parts List of Front Panel Section

Ref.No.	Part No.	Description
1	27211417	Front panel ass'y
2	27211419	Door ass'y
3	27180503	Spring
4	2010268	Cord ass'y
5	27301507	Door gear
6	27301508	Door hook
7	27301438	Damper
8	27262556	Plate ass'y,damper
9	25065452	Door switch
10	28141171	Cushion
11	28324604	Knob,open
12	28324605	Knob,power
13	28324606	Knob,stop
14	28324607	Knob,play
15	28324608	Knob A
16	28324609	Knob B
17	28324610	Knob C
18	28324611	Knob D
19	28324612	Knob E
20	24505323	FLK1 pc board ass'y
21	24505324	FLK2 pc board ass'y
22	833426060	2.6TTP+6P(BC),Self-tapping screw
23	82542006	2B+6F(BC),Binding screw
24	833426060	2.6TTP+6P(BC),Self-tapping screw
31		Cushion

### NOTES:

- Parts without part number cannot be supplied.
- The components identified by mark **△** are critical for risk of fire and electric shock.  
Replace only with part number specified.

# 5. SCHEMATIC AND P.C. BOARDS DIAGRAM

## 5.1 OVERALL WIRING DIAGRAM

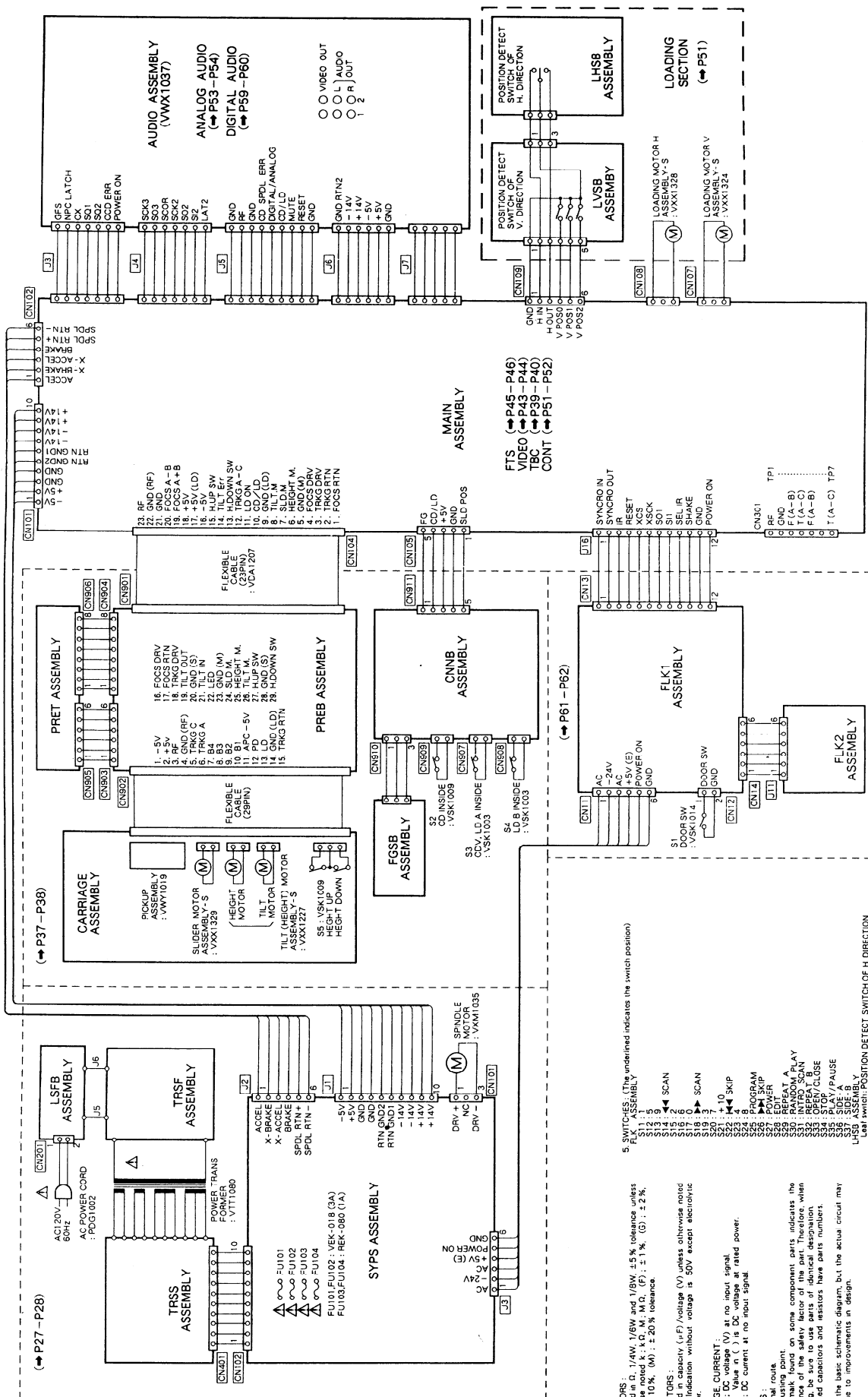

- RESISTORS:** Indicated in Ω, 1/4W, 1/8W, 1/2W, 1W, 5% tolerance unless otherwise noted; k, M, G, ±1%, (G) ±2%, (K) ±10%, (M) ±20% tolerance.
  - CAPACITORS:** Indicated in capacitance (pF) or voltage (V) unless otherwise noted; p, n, μF. Indication without voltage is 50V except electrolytic capacitor.
  - VOLTAGE CURRENT:** DC voltage (V) at no input signal. Value in ( ) is DC voltage at rated power. mA: DC current at no input signal.
  - OTHERS:**
    - : Signal route
    - : Soldering point
    - : The safety factor of the part. Therefore, when replacing, be sure to use parts of identical designation.
    - \* marked capacitors and resistors have part numbers.
- This is the basic schematic diagram, but the actual circuit may vary due to improvements in design.
- 5. SWITCHES:** (The underlined indicates the switch position)
- S1: 1. INITIALLY
  - S2: 2. SCAN
  - S3: 3. SCAN
  - S4: 4. SCAN
  - S5: 5. SCAN
  - S6: 6. SCAN
  - S7: 7. SCAN
  - S8: 8. SCAN
  - S9: 9. SCAN
  - S10: 10. SCAN
  - S11: 11. SCAN
  - S12: 12. SCAN
  - S13: 13. SCAN
  - S14: 14. SCAN
  - S15: 15. SCAN
  - S16: 16. SCAN
  - S17: 17. SCAN
  - S18: 18. SCAN
  - S19: 19. SCAN
  - S20: 20. SCAN
  - S21: 21. SCAN
  - S22: 22. SCAN
  - S23: 23. SCAN
  - S24: 24. SCAN
  - S25: 25. SCAN
  - S26: 26. SCAN
  - S27: 27. SCAN
  - S28: 28. SCAN
  - S29: 29. SCAN
  - S30: 30. SCAN
  - S31: 31. SCAN
  - S32: 32. SCAN
  - S33: 33. SCAN
  - S34: 34. SCAN
  - S35: 35. SCAN
  - S36: 36. SCAN
  - S37: 37. SCAN
  - S38: 38. SCAN
  - S39: 39. SCAN
  - S40: 40. SCAN
  - S41: 41. SCAN
  - S42: 42. SCAN
  - S43: 43. SCAN
  - S44: 44. SCAN
  - S45: 45. SCAN
  - S46: 46. SCAN
  - S47: 47. SCAN
  - S48: 48. SCAN
  - S49: 49. SCAN
  - S50: 50. SCAN
  - S51: 51. SCAN
  - S52: 52. SCAN
  - S53: 53. SCAN
  - S54: 54. SCAN
  - S55: 55. SCAN
  - S56: 56. SCAN
  - S57: 57. SCAN
  - S58: 58. SCAN
  - S59: 59. SCAN
  - S60: 60. SCAN
  - S61: 61. SCAN
  - S62: 62. SCAN
  - S63: 63. SCAN
  - S64: 64. SCAN
  - S65: 65. SCAN
  - S66: 66. SCAN
  - S67: 67. SCAN
  - S68: 68. SCAN
  - S69: 69. SCAN
  - S70: 70. SCAN
  - S71: 71. SCAN
  - S72: 72. SCAN
  - S73: 73. SCAN
  - S74: 74. SCAN
  - S75: 75. SCAN
  - S76: 76. SCAN
  - S77: 77. SCAN
  - S78: 78. SCAN
  - S79: 79. SCAN
  - S80: 80. SCAN
  - S81: 81. SCAN
  - S82: 82. SCAN
  - S83: 83. SCAN
  - S84: 84. SCAN
  - S85: 85. SCAN
  - S86: 86. SCAN
  - S87: 87. SCAN
  - S88: 88. SCAN
  - S89: 89. SCAN
  - S90: 90. SCAN
  - S91: 91. SCAN
  - S92: 92. SCAN
  - S93: 93. SCAN
  - S94: 94. SCAN
  - S95: 95. SCAN
  - S96: 96. SCAN
  - S97: 97. SCAN
  - S98: 98. SCAN
  - S99: 99. SCAN
  - S100: 100. SCAN

5.2 LSFB, TRSF, TRSS, SYPS ASSEMBLIES

SYPS ASSEMBLY

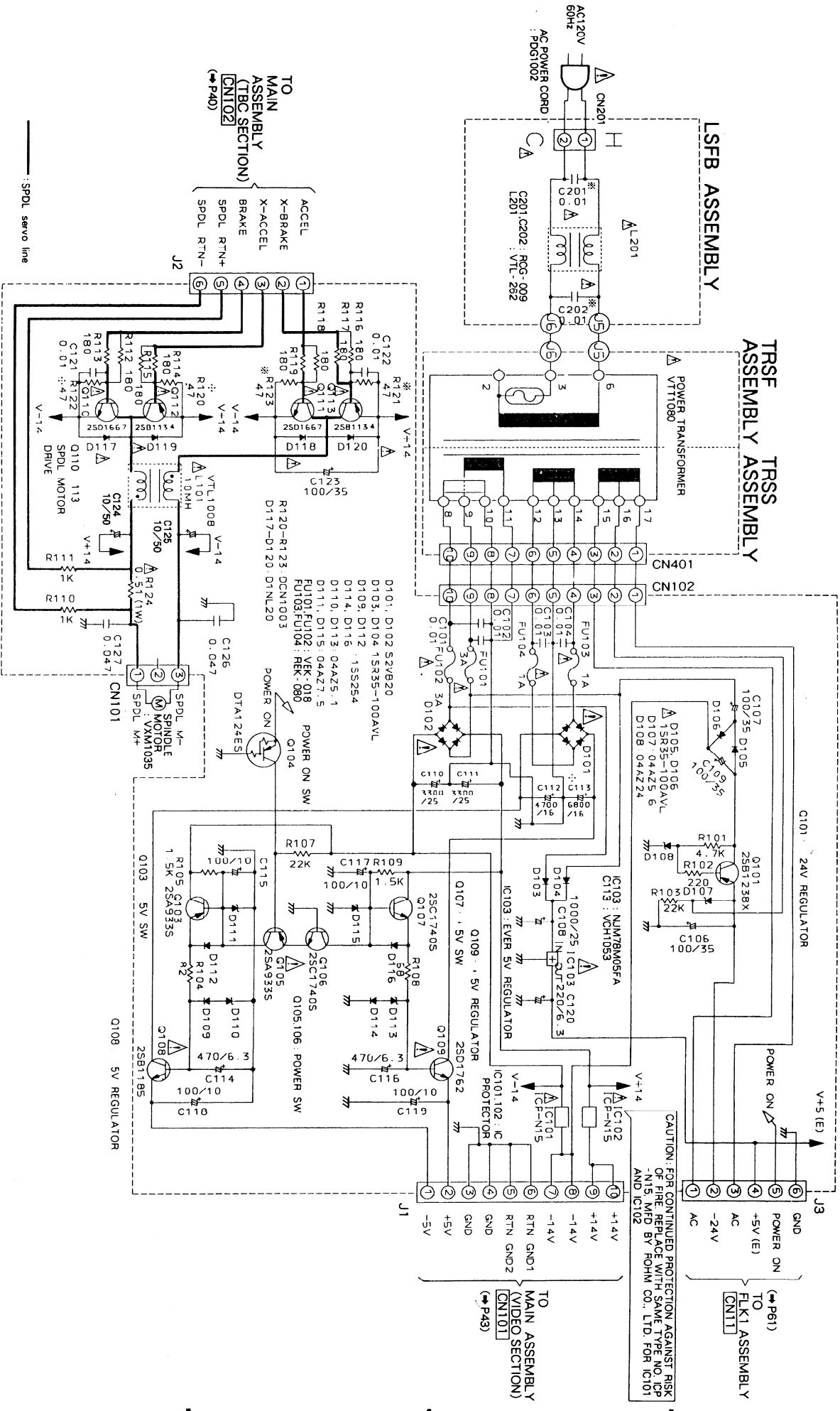

CAUTION: FOR CONTINUED PROTECTION AGAINST RISK OF FIRE, REPLACE WITH SAME TYPE AND PART NUMBER. MFD BY FOHM CO., LTD. FOR IC101 AND IC102.

A

B

C

D

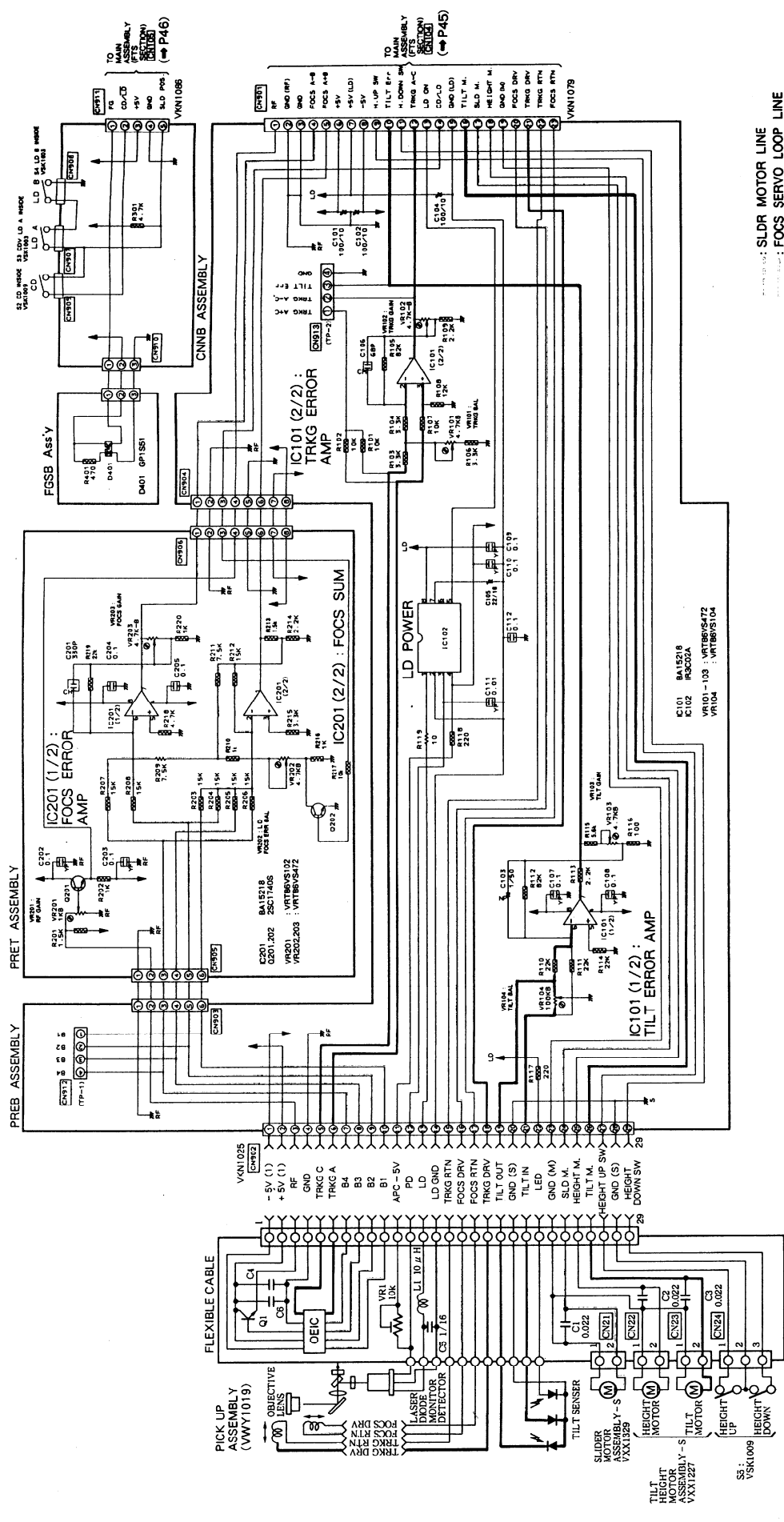

— : SLDR MOTOR LINE  
 — : FOCUS SERVO LOOP LINE  
 — : TRKG SERVO LOOP LINE  
 — : TILT SERVO LOOP LINE

IC101 BA15218  
 IC102 RB302A  
 VR101-103 : VRT86/S474  
 VR104 : VRT86/S104



MAIN ASSEMBLY (TBC SECTION)

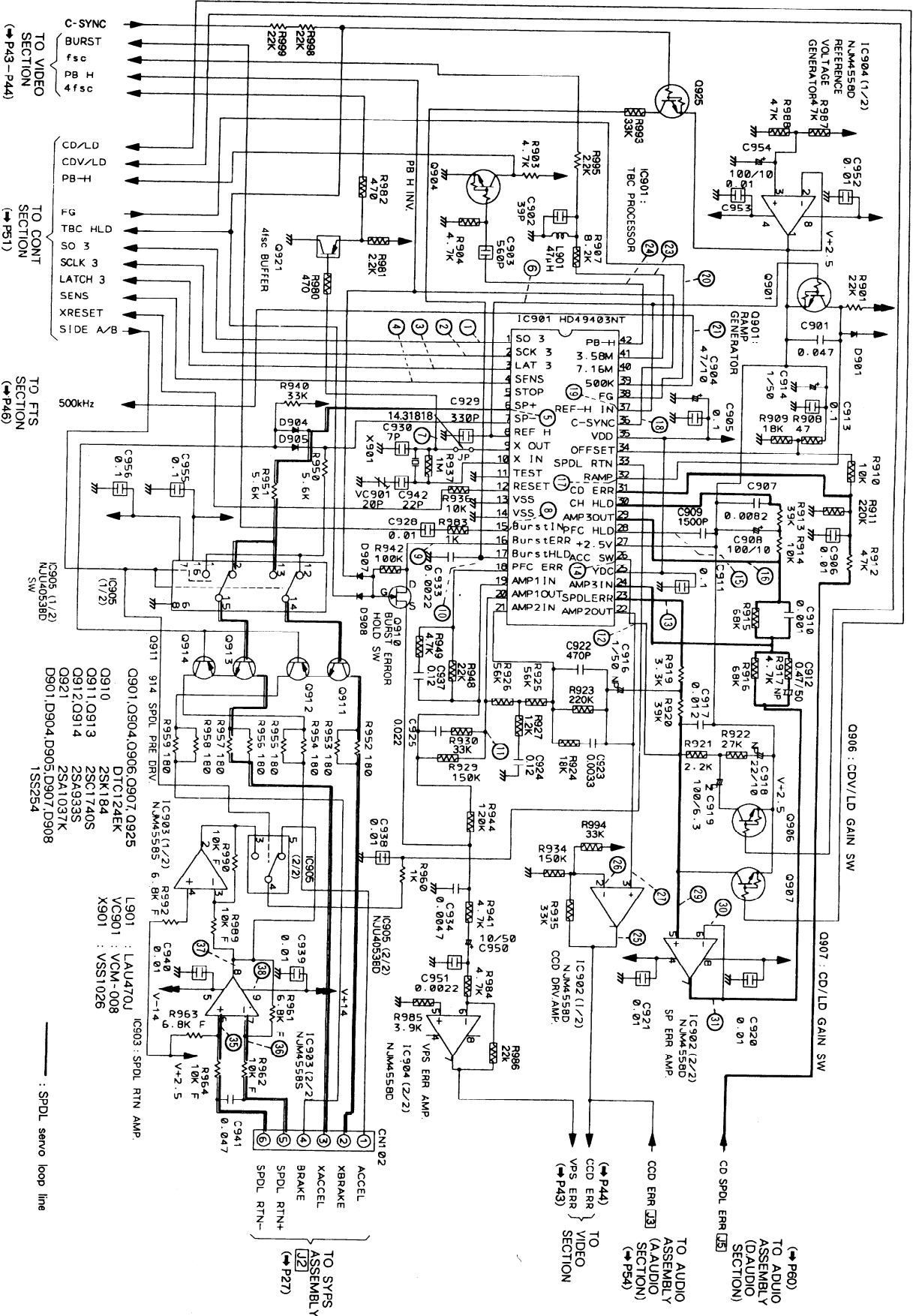

TO VIDEO SECTION (P43-P44)  
 C-SYNC  
 BURST  
 PB H  
 4 fsc

TO CONT SECTION (P51)  
 CD/LD  
 CDV/LD  
 H  
 TBC HLD  
 SO  
 SCLK 3  
 LATCH 3  
 SENS  
 XRESET  
 SIDE A/B

TO FTS SECTION (P46)  
 500kHz

IC905 (1/2)  
 N4U40538B  
 SW  
 (1/2)

O910 : O904, O906, O907, O925  
 O910 : DTC124EK  
 O911, O913 : 2SK184  
 O912, O914 : 2SC1740S  
 O921 : 2SA1037K  
 O921 : 2SA1037K  
 O901, D904, D905, D907, D908 : 1SS254

L901 : LAU470J  
 VC901 : VCM-008  
 X901 : VSS1026

IC903 : SPDL RTN AMP.  
 IC902 (1/2) : N4M558D  
 IC902 (2/2) : N4M558D  
 IC904 (2/2) : N4M558D  
 IC905 (1/2) : N4U40538B  
 IC905 (2/2) : N4U40538B  
 IC906 (2/2) : DTC124EK  
 IC907 (2/2) : VSS1026  
 IC908 (1/2) : LAU470J  
 IC909 (1/2) : VCM-008  
 IC910 (1/2) : VSS1026

ACCCEL  
 XBRAKE  
 XACCEL  
 BRAKE  
 SPDL RTN+  
 SPDL RTN-  
 TO SYRS ASSEMBLY (P27)

TO VIDEO ASSEMBLY (AUDIO SECTION) (P43)  
 TO VIDEO ASSEMBLY (VIDEO SECTION) (P44)  
 TO AUDIO ASSEMBLY (AUDIO SECTION) (P54)  
 TO AUDIO ASSEMBLY (AUDIO SECTION) (P54)  
 TO VIDEO ASSEMBLY (AUDIO SECTION) (P43)  
 TO VIDEO ASSEMBLY (VIDEO SECTION) (P44)  
 TO AUDIO ASSEMBLY (AUDIO SECTION) (P54)  
 TO AUDIO ASSEMBLY (AUDIO SECTION) (P54)

SPDL servo loop line



### 5.6 MAIN ASSEMBLY (FIS SECTION) MAIN ASSEMBLY (FIS SECTION)

(P59)  
TO AUDIO ASSEMBLY (D.AUDIO SECTION)  
TO VIDEO SECTION (P45)

--- : RF signal  
- - - : TILT servo loop  
- - - : FCS servo loop  
- - - : TRK servo loop

A

B

C

D

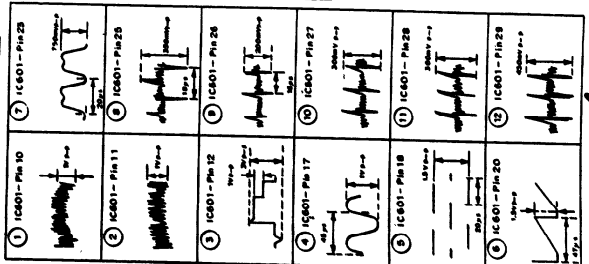
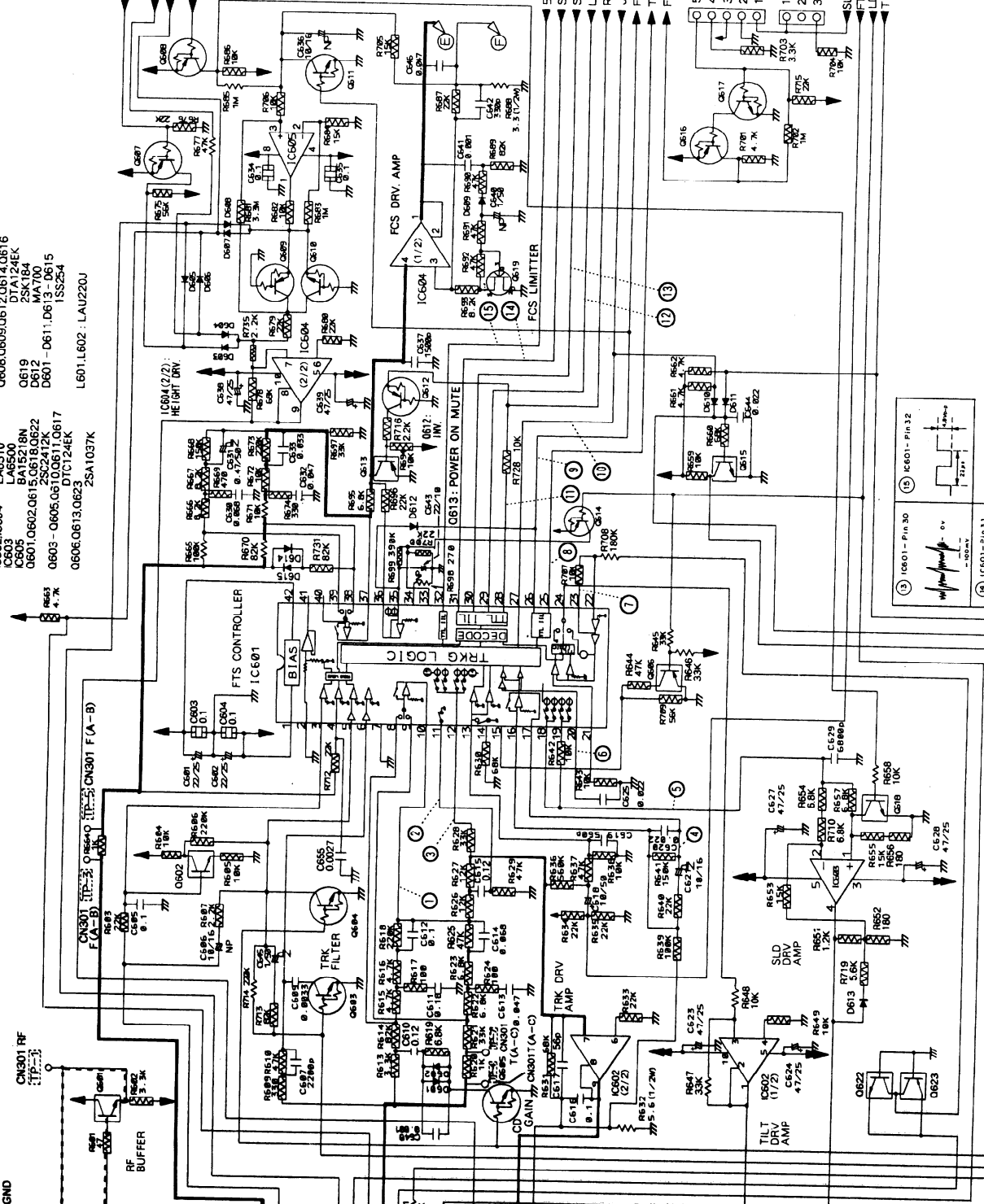

- IC501 - HA11529MT
- IC502 - CA601
- IC503 - CA601
- IC504 - CA601
- IC601 - CA601
- IC602 - CA601
- IC603 - CA601
- IC604 - CA601
- IC605 - CA601
- IC606 - CA601
- IC607 - CA601
- IC608 - CA601
- IC609 - CA601
- IC610 - CA601
- IC611 - CA601
- IC612 - CA601
- IC613 - CA601
- IC614 - CA601
- IC615 - CA601
- IC616 - CA601
- IC617 - CA601
- IC618 - CA601
- IC619 - CA601
- IC620 - CA601
- IC621 - CA601
- IC622 - CA601
- IC623 - CA601
- IC624 - CA601
- IC625 - CA601
- IC626 - CA601
- IC627 - CA601
- IC628 - CA601
- IC629 - CA601
- IC630 - CA601
- IC631 - CA601
- IC632 - CA601
- IC633 - CA601
- IC634 - CA601
- IC635 - CA601
- IC636 - CA601
- IC637 - CA601
- IC638 - CA601
- IC639 - CA601
- IC640 - CA601
- IC641 - CA601
- IC642 - CA601
- IC643 - CA601
- IC644 - CA601
- IC645 - CA601
- IC646 - CA601
- IC647 - CA601
- IC648 - CA601
- IC649 - CA601
- IC650 - CA601
- IC651 - CA601
- IC652 - CA601
- IC653 - CA601
- IC654 - CA601
- IC655 - CA601
- IC656 - CA601
- IC657 - CA601
- IC658 - CA601
- IC659 - CA601
- IC660 - CA601
- IC661 - CA601
- IC662 - CA601
- IC663 - CA601
- IC664 - CA601
- IC665 - CA601
- IC666 - CA601
- IC667 - CA601
- IC668 - CA601
- IC669 - CA601
- IC670 - CA601
- IC671 - CA601
- IC672 - CA601
- IC673 - CA601
- IC674 - CA601
- IC675 - CA601
- IC676 - CA601
- IC677 - CA601
- IC678 - CA601
- IC679 - CA601
- IC680 - CA601
- IC681 - CA601
- IC682 - CA601
- IC683 - CA601
- IC684 - CA601
- IC685 - CA601
- IC686 - CA601
- IC687 - CA601
- IC688 - CA601
- IC689 - CA601
- IC690 - CA601
- IC691 - CA601
- IC692 - CA601
- IC693 - CA601
- IC694 - CA601
- IC695 - CA601
- IC696 - CA601
- IC697 - CA601
- IC698 - CA601
- IC699 - CA601
- IC700 - CA601
- IC701 - CA601
- IC702 - CA601
- IC703 - CA601
- IC704 - CA601
- IC705 - CA601
- IC706 - CA601
- IC707 - CA601
- IC708 - CA601
- IC709 - CA601
- IC710 - CA601
- IC711 - CA601
- IC712 - CA601
- IC713 - CA601
- IC714 - CA601
- IC715 - CA601
- IC716 - CA601
- IC717 - CA601
- IC718 - CA601
- IC719 - CA601
- IC720 - CA601
- IC721 - CA601
- IC722 - CA601
- IC723 - CA601
- IC724 - CA601
- IC725 - CA601
- IC726 - CA601
- IC727 - CA601
- IC728 - CA601
- IC729 - CA601
- IC730 - CA601
- IC731 - CA601
- IC732 - CA601
- IC733 - CA601
- IC734 - CA601
- IC735 - CA601
- IC736 - CA601
- IC737 - CA601
- IC738 - CA601
- IC739 - CA601
- IC740 - CA601
- IC741 - CA601
- IC742 - CA601
- IC743 - CA601
- IC744 - CA601
- IC745 - CA601
- IC746 - CA601
- IC747 - CA601
- IC748 - CA601
- IC749 - CA601
- IC750 - CA601
- IC751 - CA601
- IC752 - CA601
- IC753 - CA601
- IC754 - CA601
- IC755 - CA601
- IC756 - CA601
- IC757 - CA601
- IC758 - CA601
- IC759 - CA601
- IC760 - CA601
- IC761 - CA601
- IC762 - CA601
- IC763 - CA601
- IC764 - CA601
- IC765 - CA601
- IC766 - CA601
- IC767 - CA601
- IC768 - CA601
- IC769 - CA601
- IC770 - CA601
- IC771 - CA601
- IC772 - CA601
- IC773 - CA601
- IC774 - CA601
- IC775 - CA601
- IC776 - CA601
- IC777 - CA601
- IC778 - CA601
- IC779 - CA601
- IC780 - CA601
- IC781 - CA601
- IC782 - CA601
- IC783 - CA601
- IC784 - CA601
- IC785 - CA601
- IC786 - CA601
- IC787 - CA601
- IC788 - CA601
- IC789 - CA601
- IC790 - CA601
- IC791 - CA601
- IC792 - CA601
- IC793 - CA601
- IC794 - CA601
- IC795 - CA601
- IC796 - CA601
- IC797 - CA601
- IC798 - CA601
- IC799 - CA601
- IC800 - CA601

5.7 MAIN ASSEMBLY (CONT SECTION), LVSB, LHSB AND SSTB ASSEMBLIES MAIN ASSEMBLY (CONT SECTION)

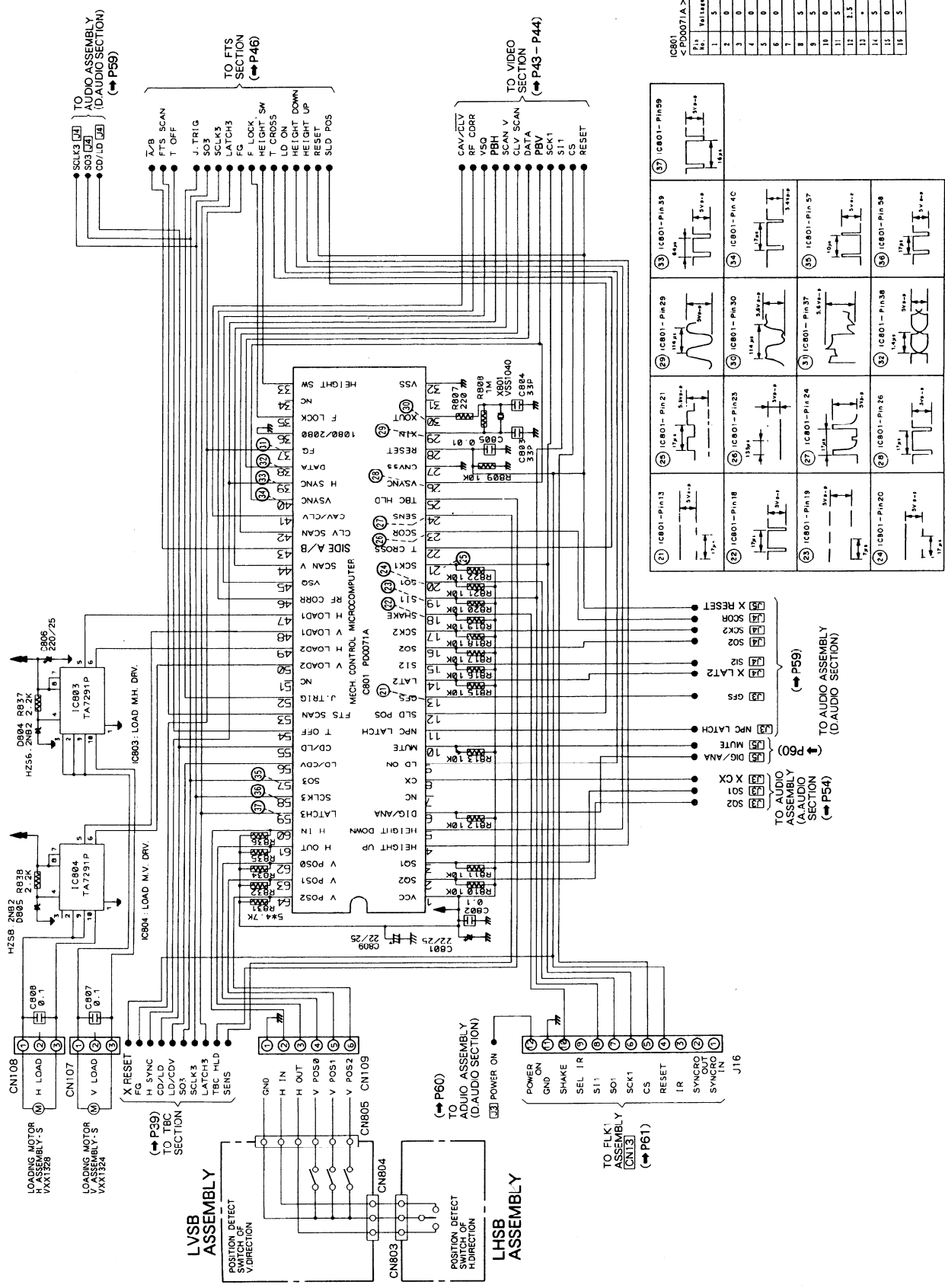

IC801 < PD0007/A >

Pin	Waveform	IC801 - Pin
1	[Waveform]	IC801 - Pin 13
2	[Waveform]	IC801 - Pin 18
3	[Waveform]	IC801 - Pin 19
4	[Waveform]	IC801 - Pin 20
5	[Waveform]	IC801 - Pin 21
6	[Waveform]	IC801 - Pin 22
7	[Waveform]	IC801 - Pin 23
8	[Waveform]	IC801 - Pin 24
9	[Waveform]	IC801 - Pin 25
10	[Waveform]	IC801 - Pin 26
11	[Waveform]	IC801 - Pin 29
12	[Waveform]	IC801 - Pin 30
13	[Waveform]	IC801 - Pin 39
14	[Waveform]	IC801 - Pin 40
15	[Waveform]	IC801 - Pin 41
16	[Waveform]	IC801 - Pin 42
17	[Waveform]	IC801 - Pin 43
18	[Waveform]	IC801 - Pin 44
19	[Waveform]	IC801 - Pin 45
20	[Waveform]	IC801 - Pin 46
21	[Waveform]	IC801 - Pin 47
22	[Waveform]	IC801 - Pin 48
23	[Waveform]	IC801 - Pin 49
24	[Waveform]	IC801 - Pin 50



A AUDIO ASSEMBLY (ANALOG AUDIO SECTION)

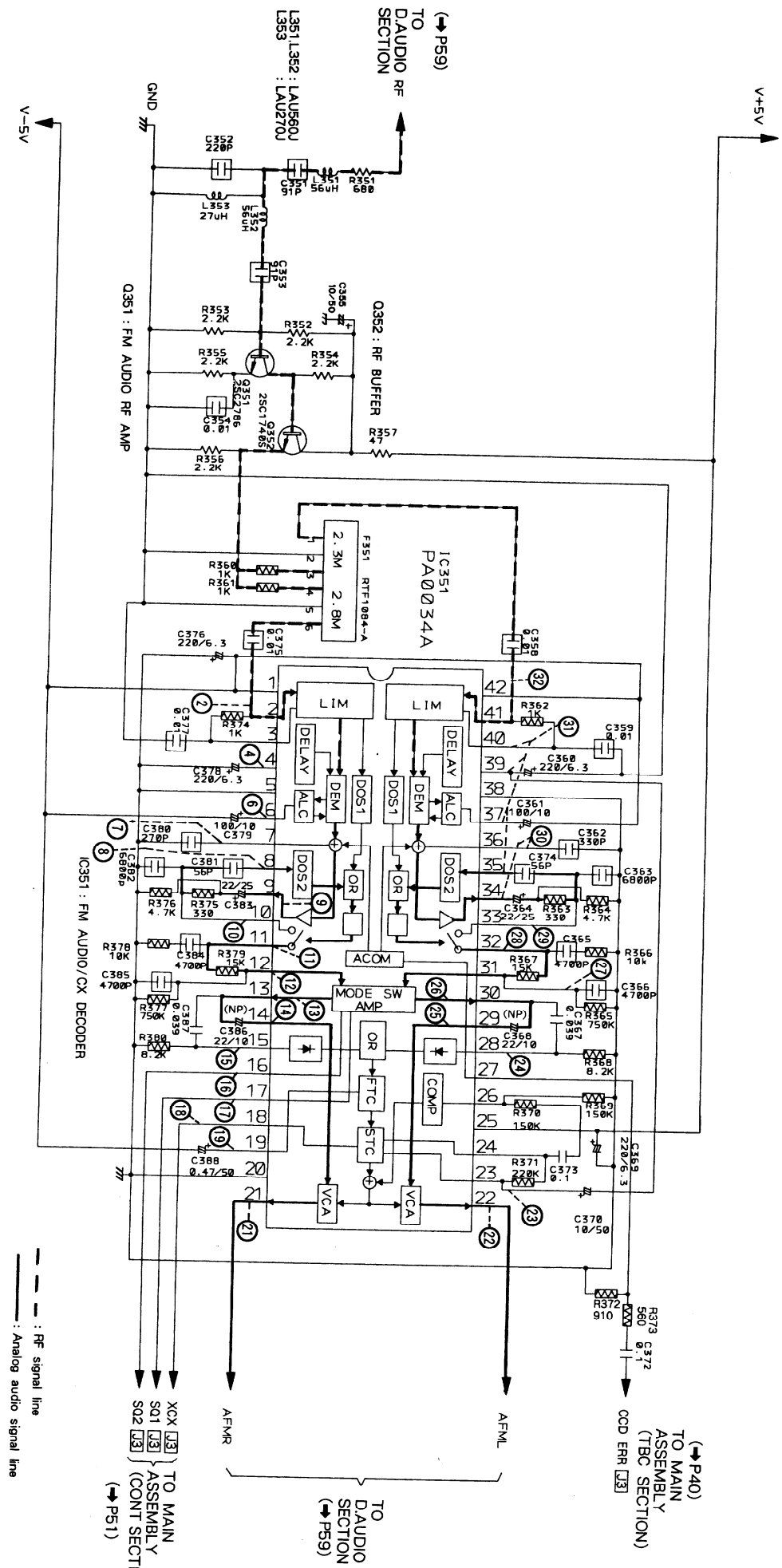

5.9 AUDIO ASSEMBLY (DIGITAL AUDIO SECTION)

AUDIO ASSEMBLY (DIGITAL AUDIO SECTION)

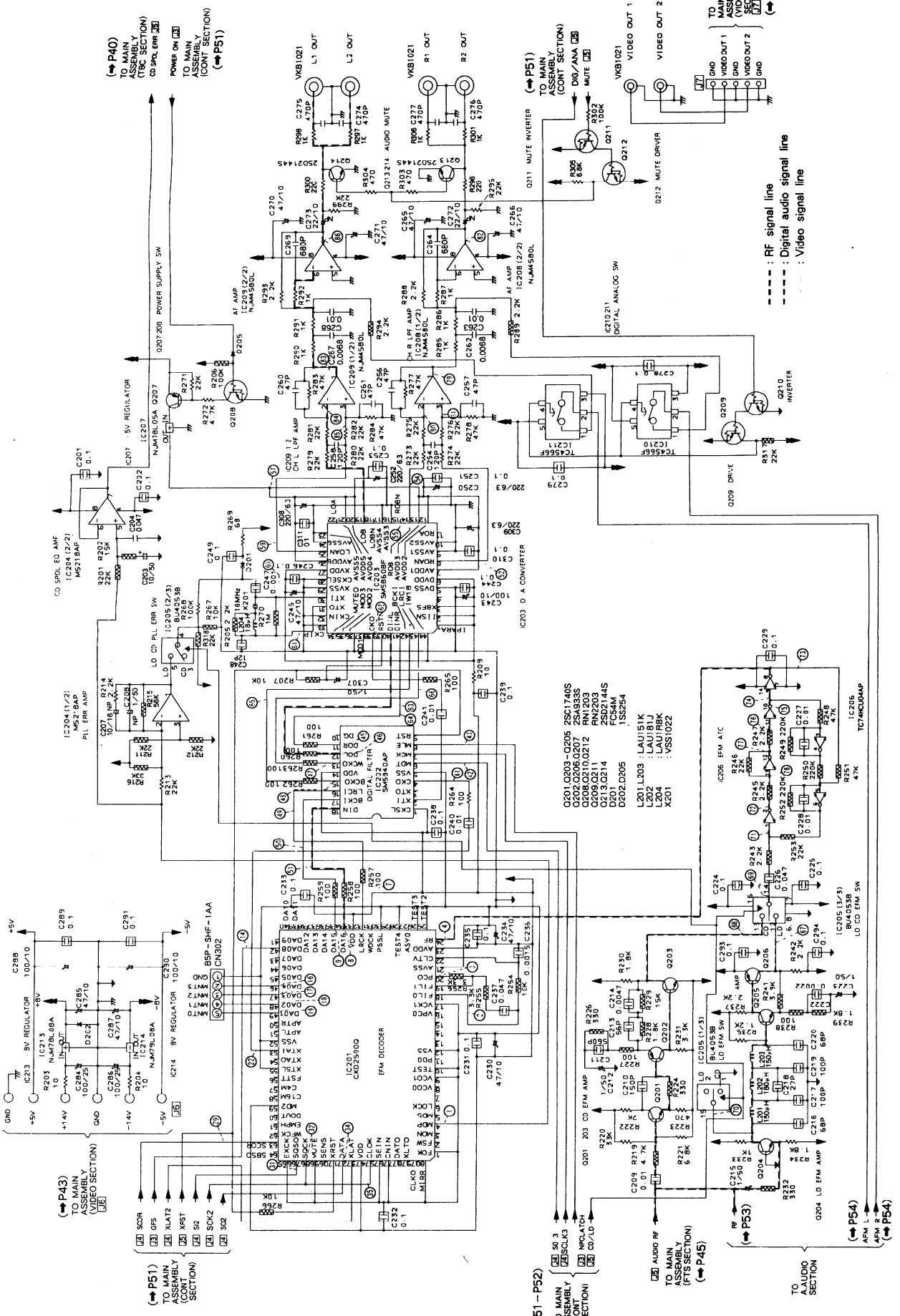

A

B

C

D

IC201- Pin 4

Pin No.	Pin	Pin	Pin	Pin	Pin
No.	1	2	3	4	5
1	0	21	3	41	51
2	0	22	2,3	42	52
3	0	23	4,8	43	53
4	*	24	*	44	54
5	0	25	9	45	55
6	4,8	26	9	46	56
7	0	27	17	47	57
8	4,8	28	9	48	58
9	0	29	9	49	59
10	0	30	9	50	60
11	0	31	*	51	71
12	0	32	*	52	72
13	0	33	4,8	53	73
14	0	34	*	54	74
15	0	35	*	55	75
16	4,8	36	*	56	76
17	0	37	*	57	77
18	*	38	*	58	78
19	2,4	39	*	59	79
20	*	40	*	60	80

IC201- Pin 34

Pin No.	Pin	Pin	Pin	Pin	Pin
No.	1	2	3	4	5
1	4,8	16	0	31	*
2	4,8	17	0	32	*
3	4,8	18	*	33	*
4	0	19	*	34	0
5	0	20	4,8	35	4,8
6	4,8	21	4,8	36	4,8
7	4,8	22	*	37	0
8	0	23	0	38	4,8
9	0	24	0	39	4,8
10	0	25	*	40	*
11	0	26	4,8	41	*
12	4,8	27	0	42	*
13	4,8	28	0	43	*
14	*	29	0	44	4,8
15	*	30	*		

IC201- Pin 53

Pin No.	Pin	Pin	Pin	Pin	Pin
No.	1	2	3	4	5
1	4,8	16	0	31	*
2	4,8	17	0	32	*
3	4,8	18	*	33	*
4	0	19	*	34	0
5	0	20	4,8	35	4,8
6	4,8	21	4,8	36	4,8
7	4,8	22	*	37	0
8	0	23	0	38	4,8
9	0	24	0	39	4,8
10	0	25	*	40	*
11	0	26	4,8	41	*
12	4,8	27	0	42	*
13	4,8	28	0	43	*
14	*	29	0	44	4,8
15	*	30	*		

IC204

Pin No.	Pin	Pin	Pin	Pin	Pin
No.	1	2	3	4	5
1	-1,6				
2	2,5				
3	2,5				
4	-1,5				
5	2,5				
6	2,5				
7	2,8				
8	2,8				
9	0				
10	0				
11	0				
12	0				
13	0				
14	0				
15	0				
16	5				

IC202 - Pin 7

Pin No.	Pin	Pin	Pin	Pin	Pin
No.	1	2	3	4	5
1	0				
2	3,6				
3	2,5				
4	2,5				
5	0				
6	0				
7	-5				
8	0				
9	0				
10	0				
11	0				
12	0				
13	0				
14	0				
15	0				
16	5				

IC205

Pin No.	Pin	Pin	Pin	Pin	Pin
No.	1	2	3	4	5
1	0				
2	0				
3	0				
4	0				
5	0				
6	0				
7	0				
8	0				
9	0				
10	0				
11	0				
12	0				
13	0				
14	5				

IC206

Pin No.	Pin	Pin	Pin	Pin	Pin
No.	1	2	3	4	5
1	5				
2	0				
3	0				
4	0				
5	0				
6	0				
7	0				
8	0				
9	0				
10	0				
11	0				
12	0				
13	0				
14	5				

IC208

Pin No.	Pin	Pin	Pin	Pin	Pin
No.	1	2	3	4	5
1	0				
2	0				
3	0				
4	0				
5	0				
6	0				
7	0				
8	0				
9	0				
10	0				
11	0				
12	0				
13	0				
14	0				
15	0				
16	0				

IC209

Pin No.	Pin	Pin	Pin	Pin	Pin
No.	1	2	3	4	5
1	0				
2	0				
3	0				
4	0				
5	0				
6	0				
7	0				
8	0				
9	0				
10	0				
11	0				
12	0				
13	0				
14	0				
15	0				
16	0				

IC213

Pin No.	Pin	Pin	Pin	Pin	Pin
No.	1	2	3	4	5
1	0				
2	0				
3	11				

IC214

Pin No.	Pin	Pin	Pin	Pin	Pin
No.	1	2	3	4	5
1	0				
2	-11,5				
3	0				

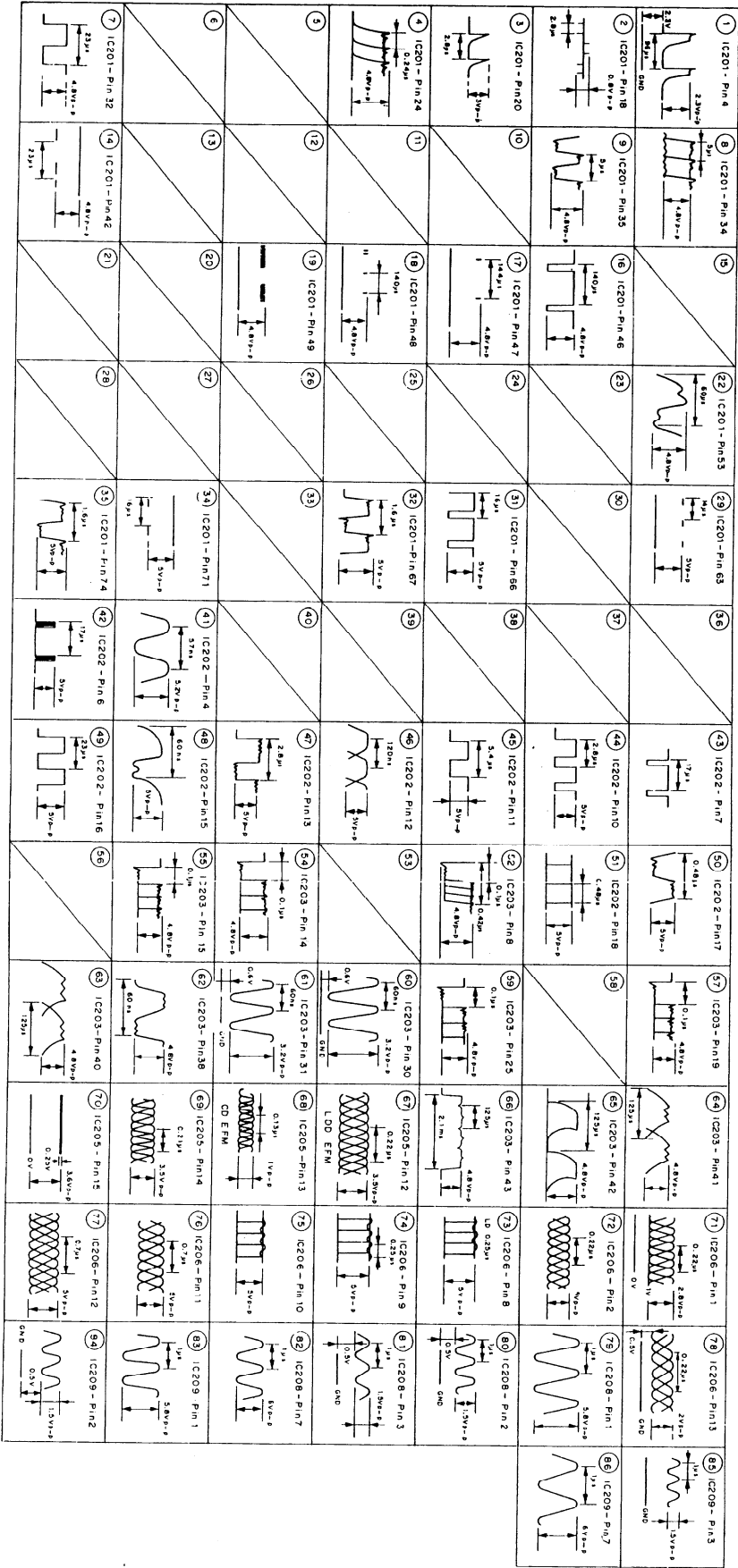

5.10 FLK1, FLK2 ASSEMBLIES

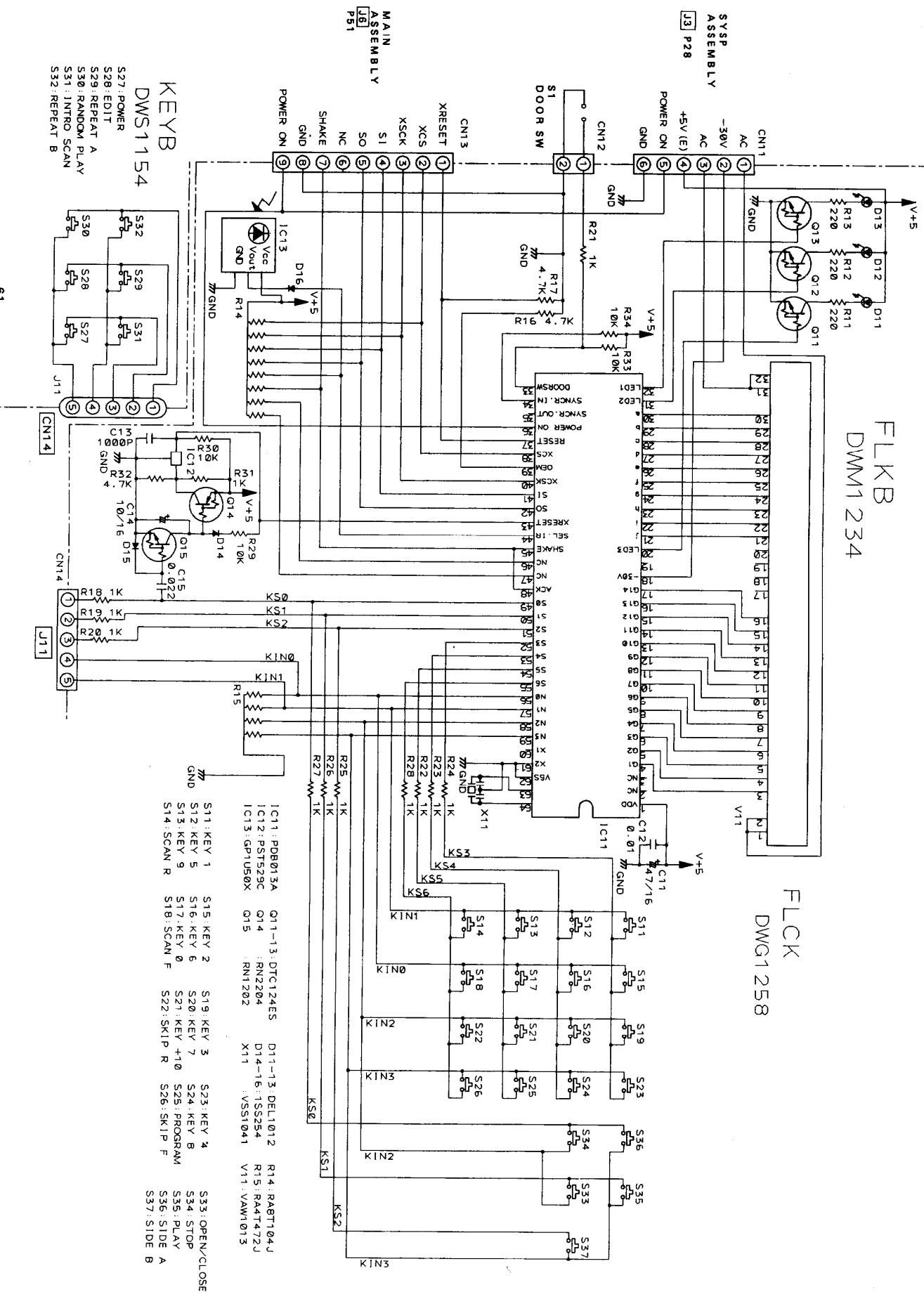



A

B

C

D

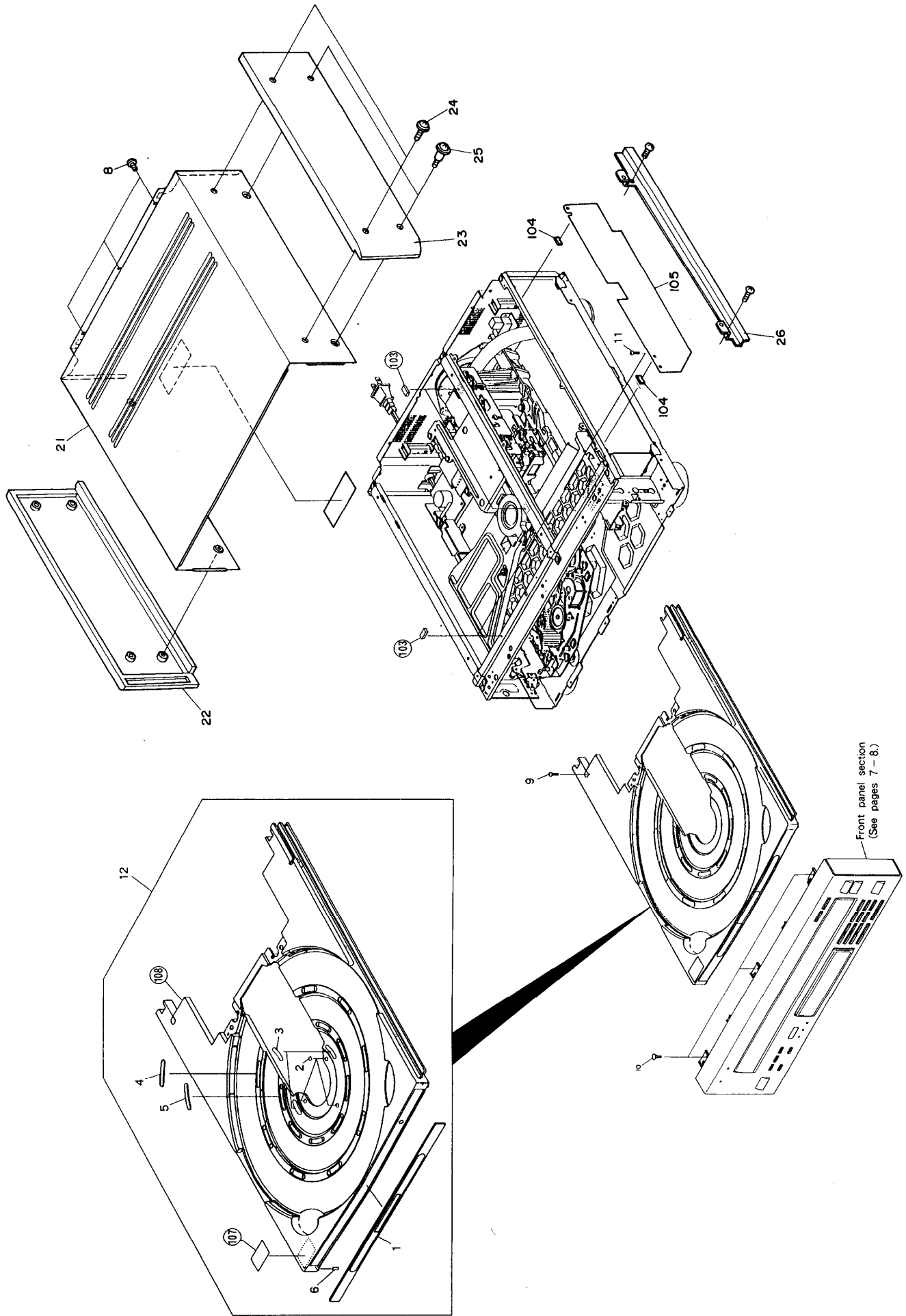

Front panel section  
(See pages 7 - 8.)

3.2 FRONT PANEL SECTION

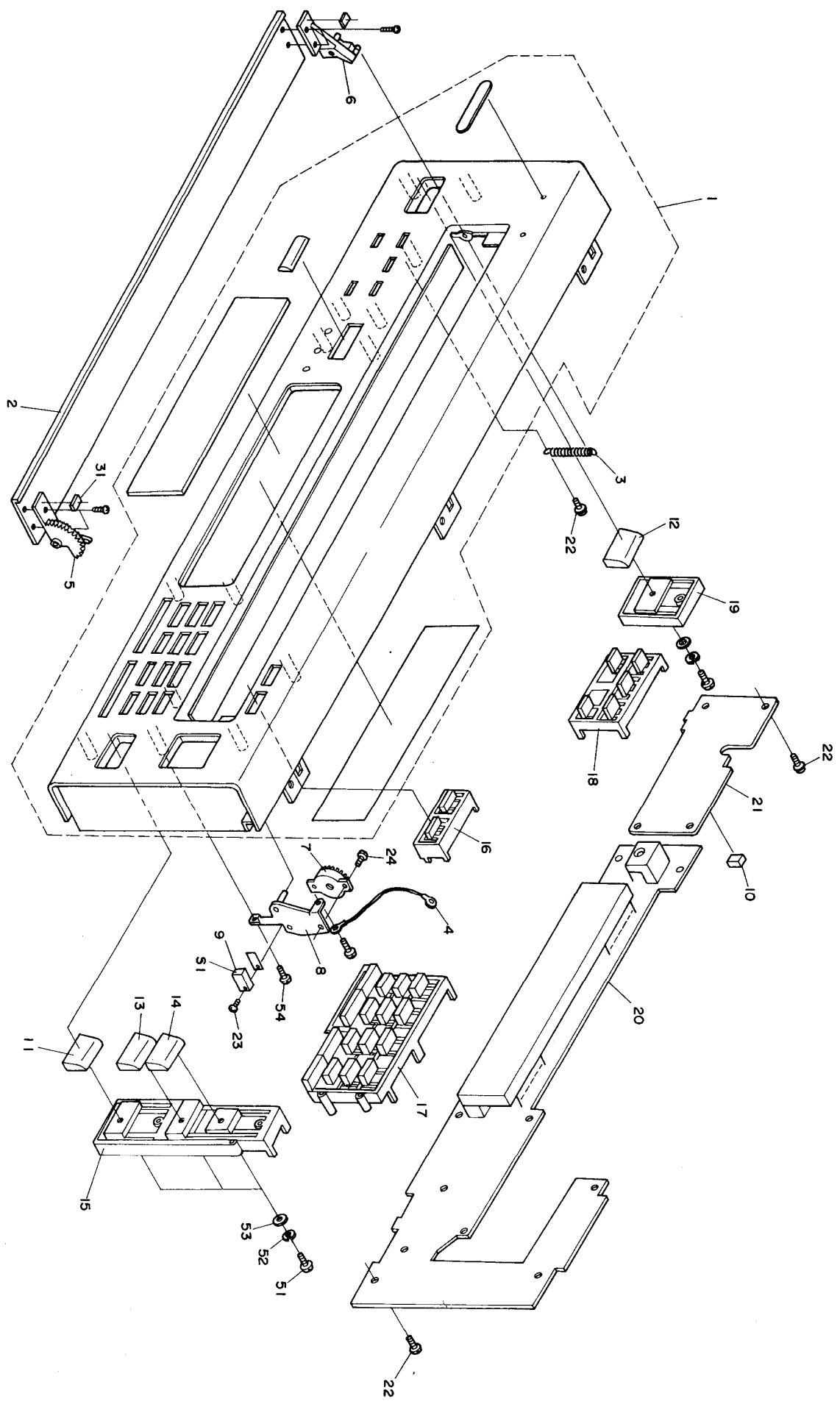

A

B

C

D

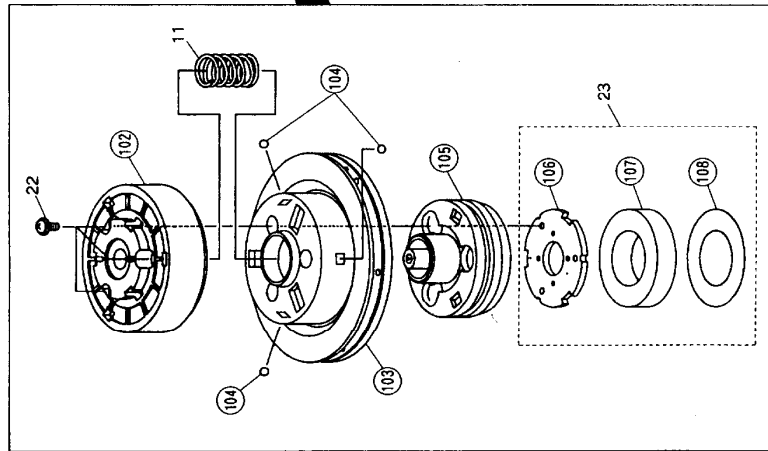
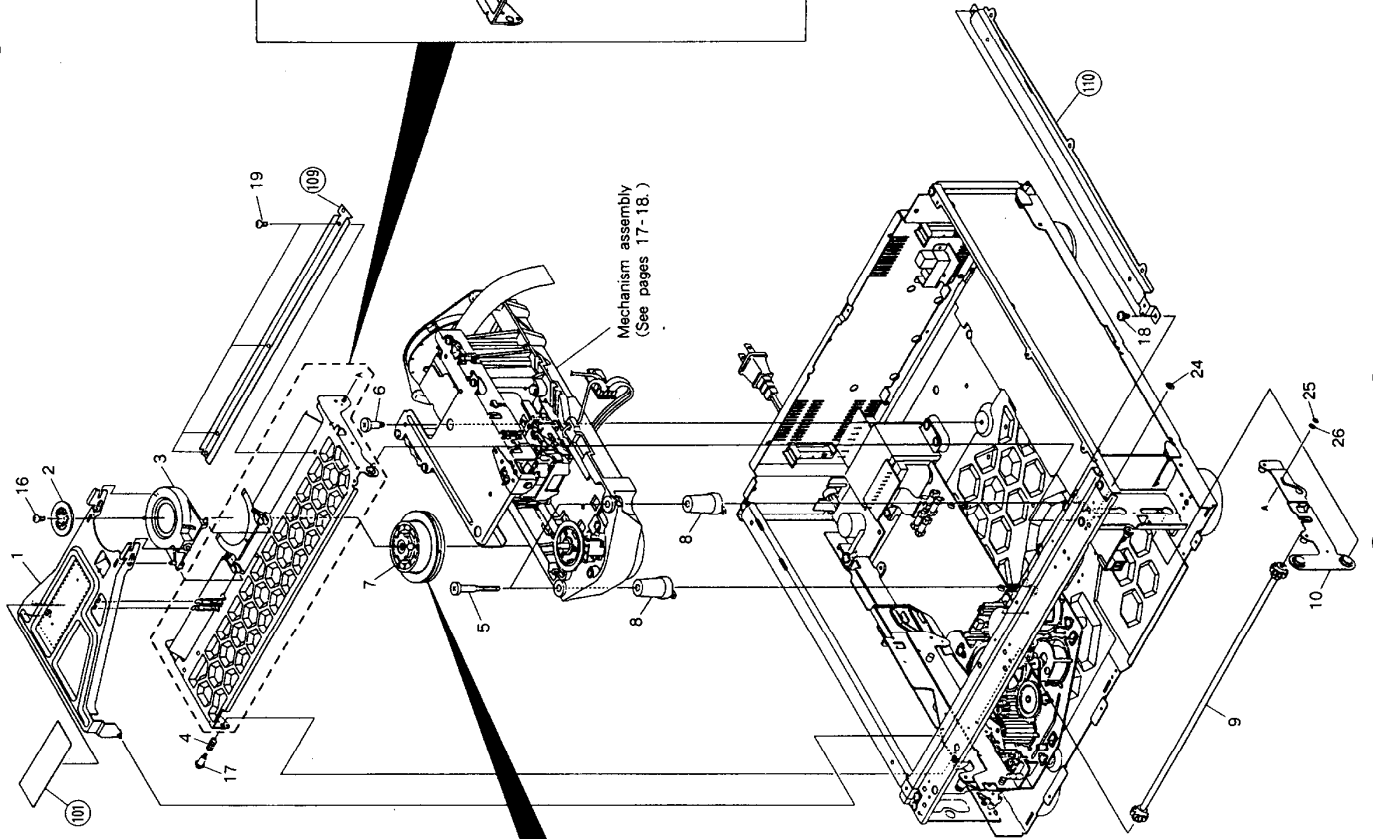
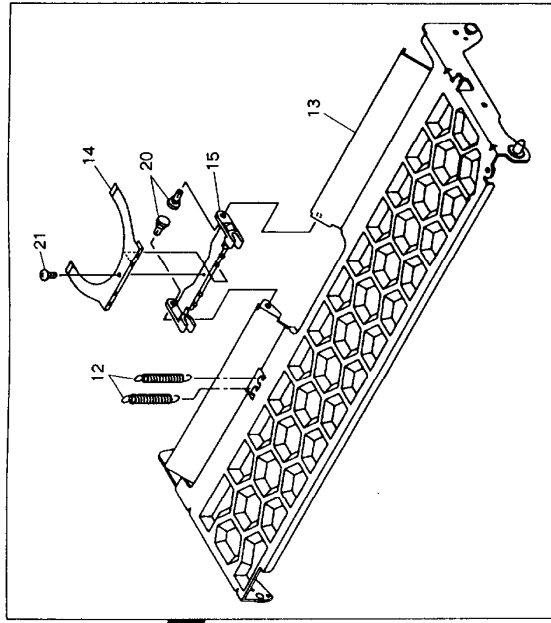

A

B

C

D

1 | 2 | 3 | 4 | 5 | 6

1 | 2 | 3 | 4 | 5 | 6

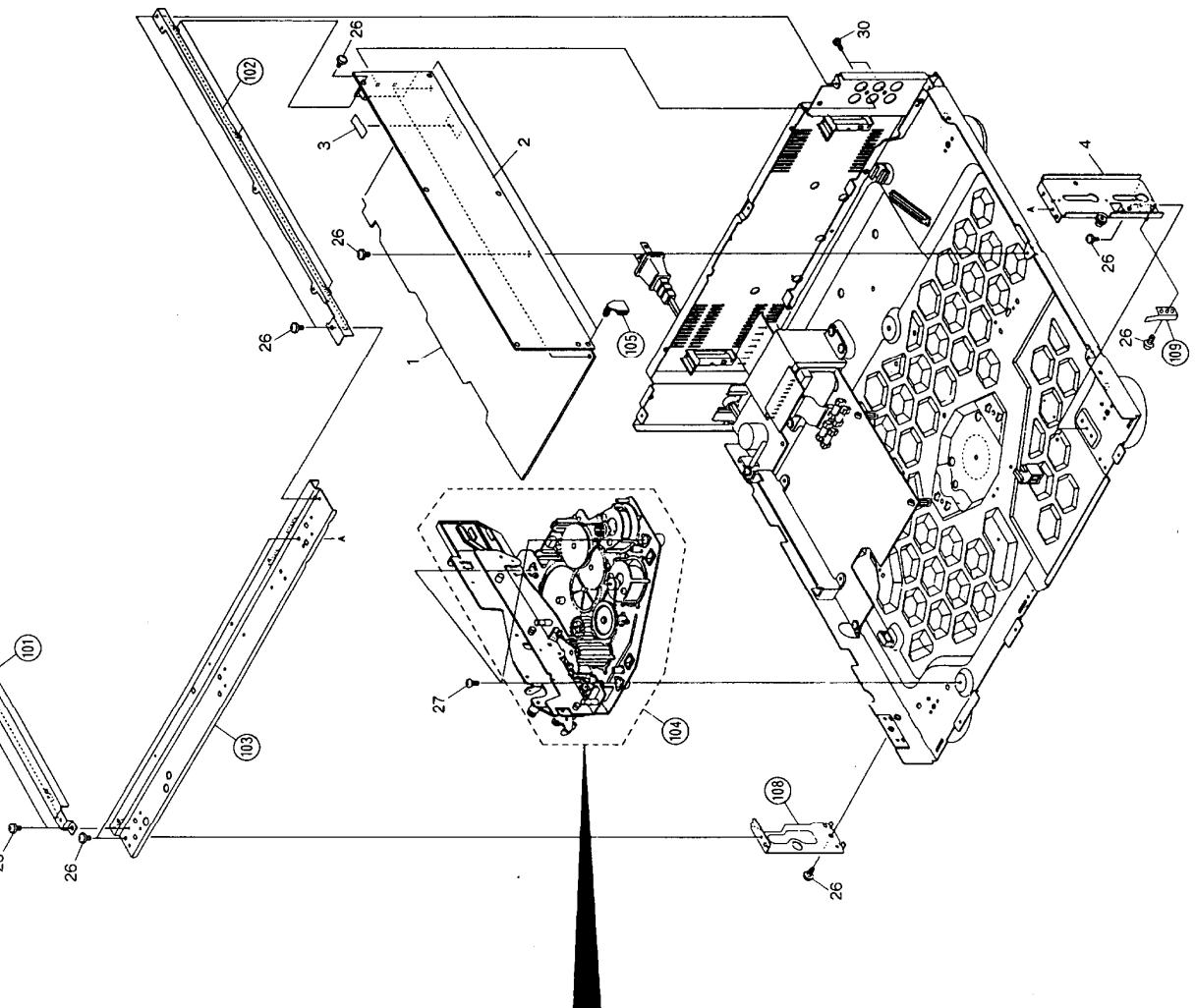
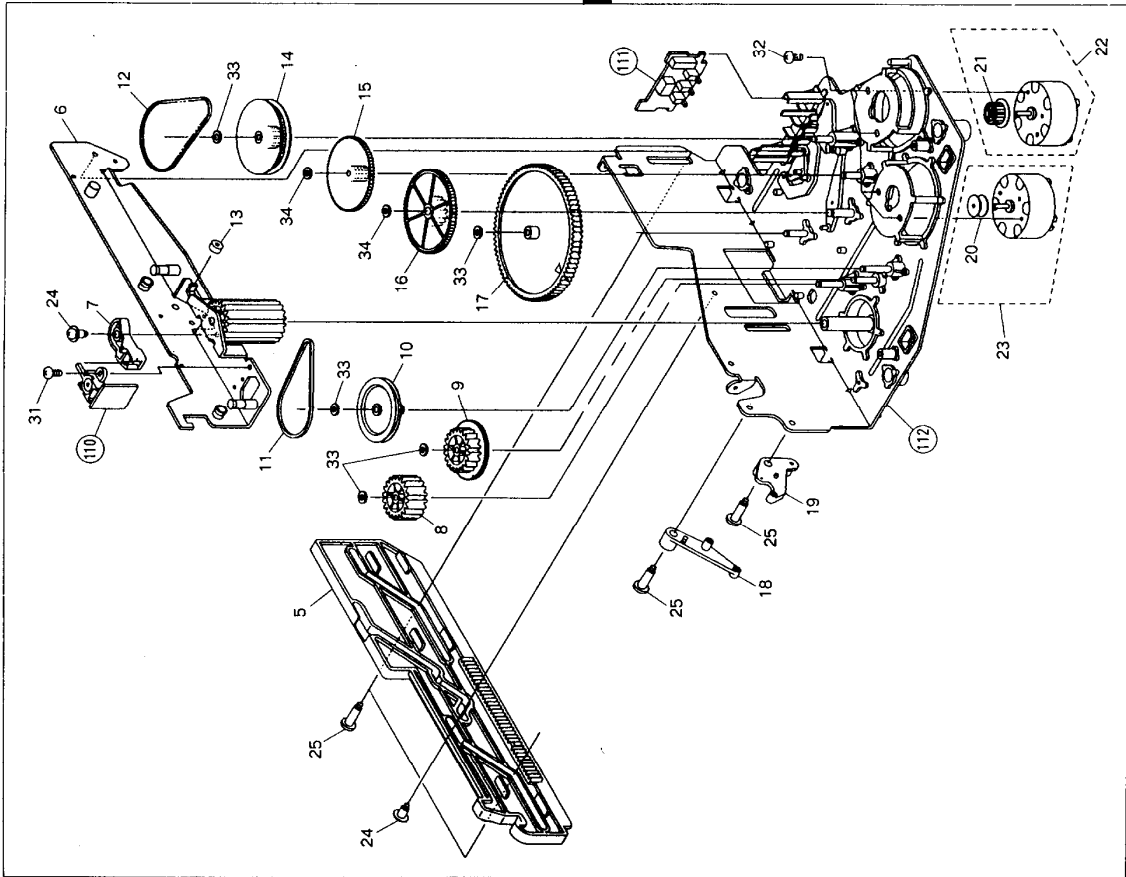

A | B | C | D

3.6 MECHANISM ASSEMBLY

1 2 3 4 5 6

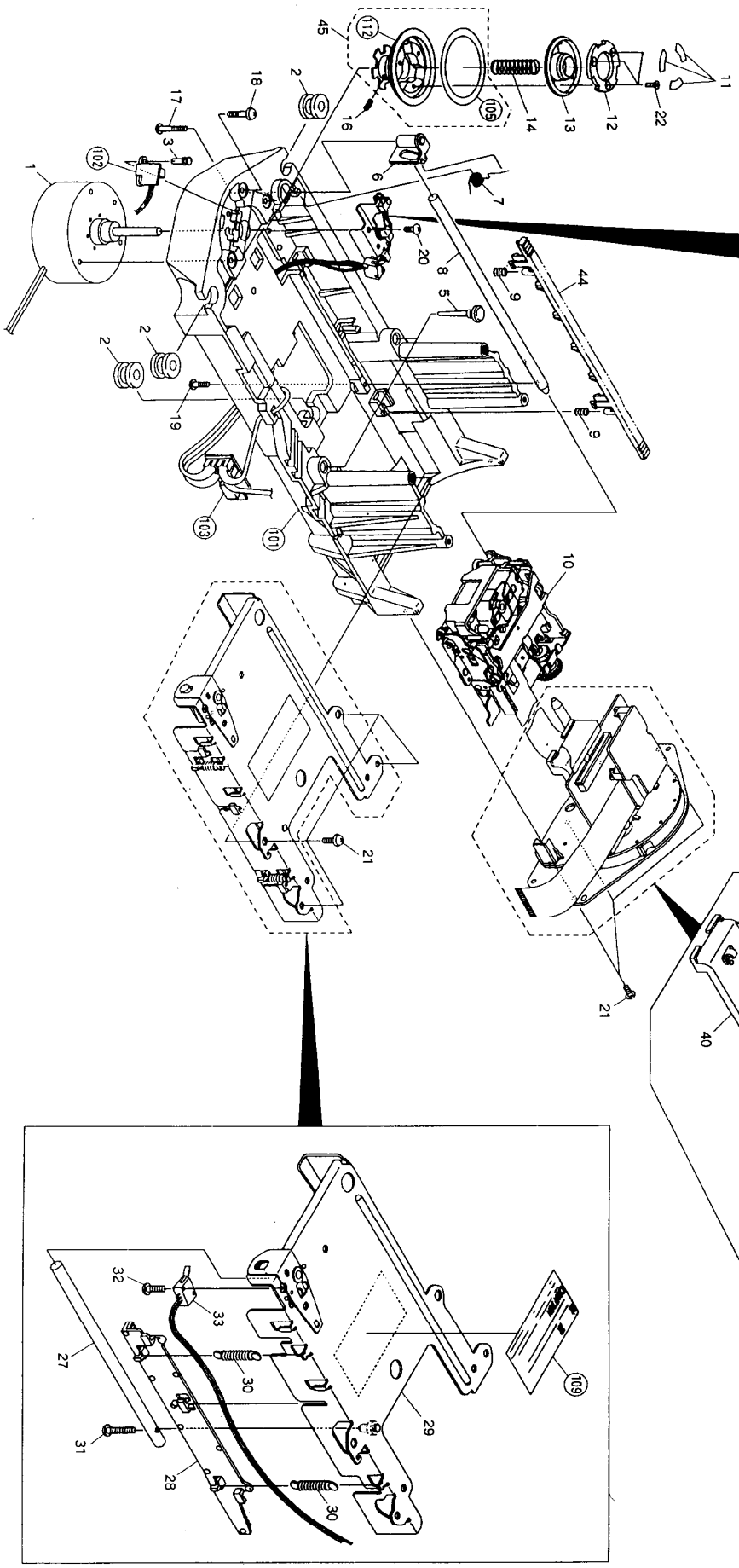
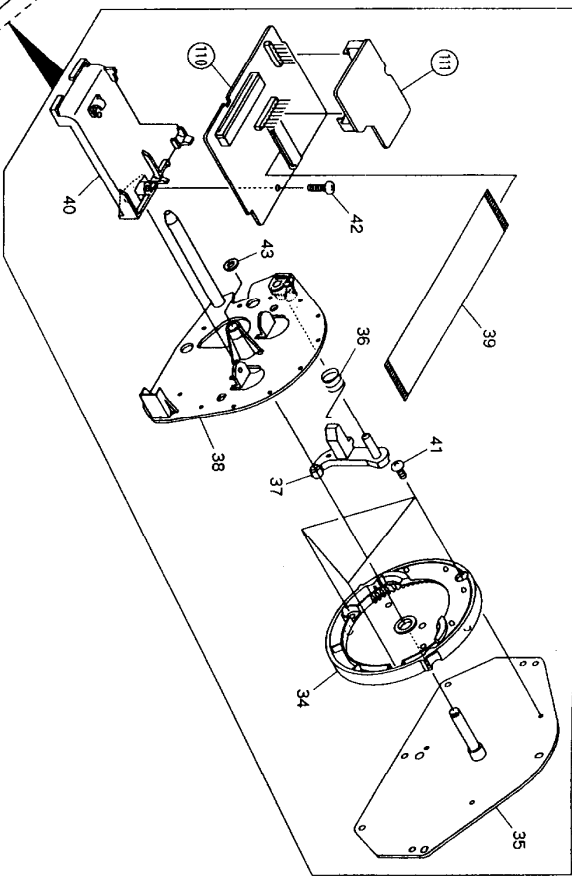
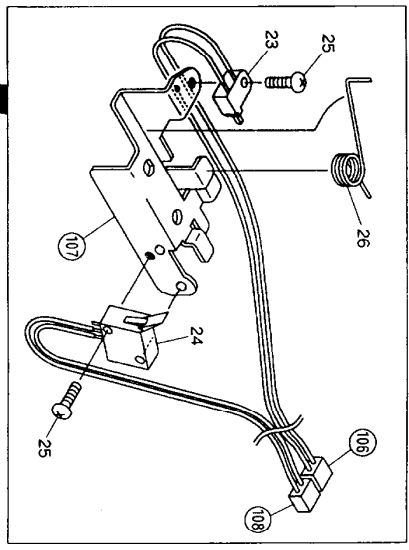

1 | 2 | 3 | 4 | 5 | 6

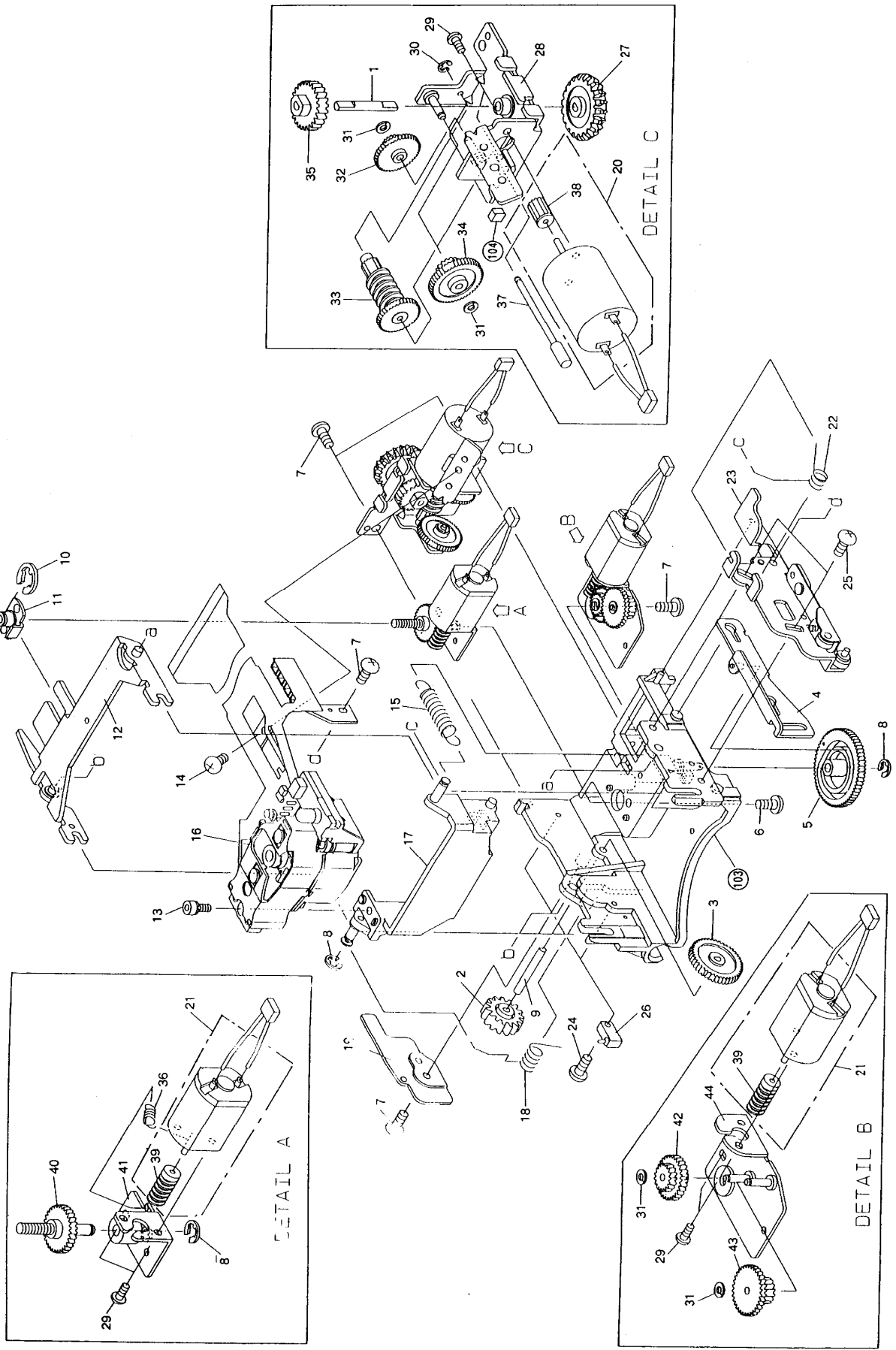

A | B | C | D

1 | 2 | 3 | 4 | 5 | 6

### 3.3 CLAMPER SECTION

#### Parts List of Clamper Section

Ref.No.	Part No.	Description	Ref.No.	Part No.	Description
1	27301510	Clamp arm ass'y	101		Cushion
2	27301511	Clamper head	102	27301540	Clamper cover
3	27301512	Clamper holder ass'y	103	27301543	Disc clamper ass'y
4	27180479	Arm spring	104	27301542	Stellball
5	801482	Screw A	105	27301541	Centering hub B
6	801483	Screw B	106	27262557	Yoke plate B
7	27301513	Clamper ass'y	107		Magnet
8	27301597	Mechanism support	108		Gap sheet
9	27301515	Synchro gear ass'y	109		Arm reinforced plate
10	27301598	Roller plate R ass'y	110	27130693	Center bracket
11	27180504	Centering spring B	111	27301548	Mechanism ass'y
12	27180505	Arm spring			
13	27301599	Clamper arm A ass'y			
14	27180506	Plate spring			
15	27301600	Parallel link			
16	801489	Sems screw			
17	800531	Screw			
18	834430068	3TTS+6B(BC),Self-tapping screw			
19	834426068	2.6TTS+6B(BC),Self-tapping screw			
20	880021	Plastic rivert			
21	838120040	2TTB+4P,Screw			
22	82142004	2P+4F(BC),Pan head screw			
23	27301514	Magnet ass'y			
24	870151	Washer			
25	893025	ES-2.5,E ring			
26	870152	Washer			

#### NOTES:

- Parts without part number cannot be supplied.
- The components identified by mark **▲** are critical for risk of fire and electric shock.  
Replace only with part number specified.



## 3.5 LOADING SECTION

## Parts List of Base Section

Ref.No.	Part No.	Description
1	24505333	SYPS pc board ass'y
2	252128	△ 1A,Fuse(FU103,FU104)
3	252127	△ 3A,Fuse(FU101,FU102)
4	2300803	△ VTT1080,Power transformer
5	253176	△ Power supply cord
6	27301502	△ Strainrelief
7	28141119	Door dump rubber
8	27175271	Insulator F ass'y
11	27175276	Insulator R ass'y
12	834430068	3TTS+6B(BC),Self-tapping screw
13	838430068	3TTB+6B(BC),Self-tapping screw
14	801490	Sems screw
15	834430168	3TTS+16B(BC),Self-tapping screw
16	27190852	Tray stopper
17	838430068	3TTB+6B(BC),Self-tapping screw
18	28141174	Cushion
19	838630080	3TTB+8P(CU),Self-tapping screw
101	24505335	TRSS pc board ass'y
102	24505336	TRSF pc board ass'y
103	24505334	LSFB pc board ass'y
104		Cord holder
105		Pc board support
106		Pc board hinge
107		Wire clip
108		Pc board holder
109		Pc board support
110		Pc board support
111		Pc board support
112	27121528	Rear panel
113		Label
114	27301516	Under base
115		Cord clamper

## Parts List of Loading Section

Ref.No.	Part No.	Description
1	24505325	MAIN pc board ass'y
2	24505326	AUDIO pc board ass'y
3	27301591	Case sheet
4	27301517	Stay R ass'y
5	27301519	Slide cam
6	27301520	Roller plate L ass'y
7	27301521	Switch lever
8	27301522	Follow gear
9	27301523	Gear B
10	27301524	Gear pulley
11	27301459	Belt
12	27301525	Synchro belt
13	27265244	Stop ring
14	27301526	Timing pulley ass'y
15	27301527	Gear D
16	27301528	Gear A
17	27301529	Cam gear
18	27301530	Lock arm
19	27301531	Lever OC
20		Motor pulley
21		Motor pulley
22	24502271	Loading motor V ass'y
23	24502272	Loading motor H ass'y
24	801484	Screw B
25	801485	Screw C
26	834430068	3TTS+6B(BC),Self-tapping screw
27	838430088	3TTB+8B(BC),Self-tapping screw
30	838430068	3TTB+6B(BC),Self-tapping screw
31	82512604	2.6B+4F,Pan head screw
32	801491	2.6B+4F(Cu),Pan head screw
33	870153	Washer
34	870151	Washer
101	27130694	Bracket L
102	27301540	Pc board holder
103	27110708	Front bracket
104	27301518	Loading ass'y
105		Pc board holder
108		Side stay (L)
109	27267784	Carry guide
110	24505331	LHSB pc board ass'y
111	24505332	LVSb pc board ass'y

## NOTES:

- Parts without part number cannot be supplied.
- The components identified by mark △ are critical for risk of fire and electric shock.  
Replace only with part number specified.



### 3.7 CARRIAGE ASSEMBLY

#### Parts List of Carriage Assembly

Ref.No.	Part No.	Description	Ref.No.	Part No.	Description
1	27260316	SL shaft B	35	27301577	SL gear G
2	27301563	SL gear F	36	27180515	Spring M
3	27301564	SL gear E	37	27260318	SL shaft A
4	27301565	Slide plate ass'y	38	27301578	SL gear A
5	27301566	TL cam gear	39	27301579	AF worm
6	801495	Sems screw	40	27301580	AF gear ass'y
7	838426058	2.6TTB+5B(BC)Self-tapping screw	41	27301581	AF holder ass'y
8	893020	ES-2,E ring	42	27301582	TL gear A
9	27260317	SL shaft C	43	27301583	TL gear B
10	893040	ES-4,Stop ring	44	27301584	TL base ass'y
11	27301567	AF plate ass'y	45	27301585	Dump rubber
12	27301568	AF arm ass'y	46	27301586	Carriage ass'y
13	84112606	Bolt			
14	833426048	2.6TTP+4B(BC),Self-tapping screw			
15	27180509	Tilt spring			
16	24110013	VWY1019,Pickup ass'y			
17	27301569	PU holder ass'y			
18	27180510	AF spring L			
19	27301570	AF stopper			
20	24502274	Slide motor ass'y			
21	24502273	Tilt motor ass'y			
22	27180511	AF spring R			
23	27301571	TAN base ass'y			
24	83420078	Self-tapping screw			
25	801496	Sems screw			
26	25065453	Slide switch (S5)			
27	27301572	SL gear H			
28	27301573	SL base ass'y			
29	801497	Screw			
30	893012	Stop ring			
31	870156	Washer			
32	27301574	SL gear B			
33	27301575	SL gear C			
34	27301576	SL gear D			

#### NOTES:

- Parts without part number cannot be supplied.
- The components identified by mark **▲** are critical for risk of fire and electric shock.  
Replace only with part number specified.

## 4. P. C. BOARDS LOCATION

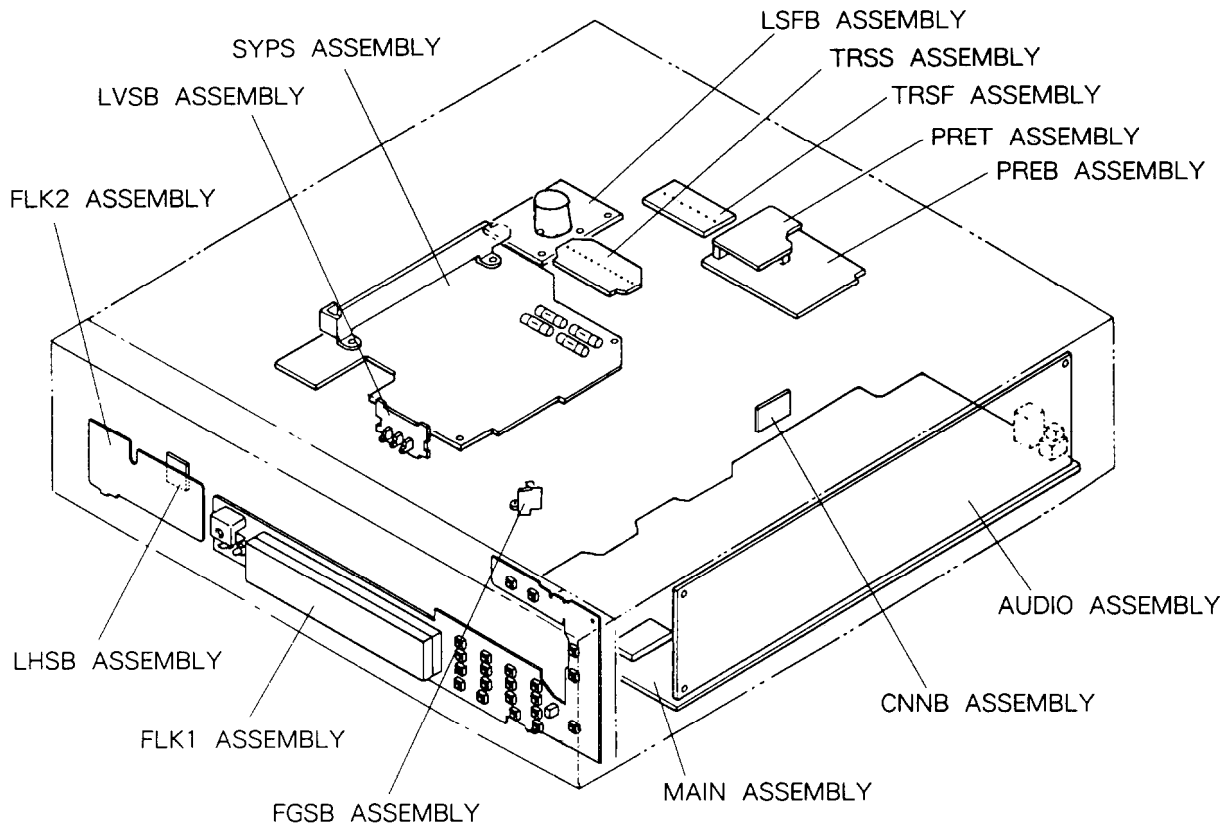

SYPS : **SYSTEM POWER SUPPLY**  
 LVSB : **LOADING VERTICAL SWITCH BOARD**  
 FLKB : **FLUORESCENT AND KEY BOARD**  
 MAIN : **MAIN**  
 CNNB : **CONNECTOR BOARD**  
 AUDIO: **AUDIO**  
 PREB : **PRE AMPLIFIER BOTTOM BOARD**  
 PRET : **PRE AMPLIFIER TOP BOARD**  
 TRSF : **TRANSFORMER PRIMARY BOARD**  
 TRSS : **TRANSFORMER SECONDARY BOARD**  
 LSFB : **LINE SURGE FILTER BOARD**  
 LHSB : **LOADING HORIZONTAL SWITCH BOARD**  
 FGSB : **FG SWITCH BOARD**

**Parts List of Mechanism Assembly**

Ref.No.	Part No.	Description	Ref.No.	Part No.	Description
1	24502270	Spindle motor	37	27301558	Lock lever
2	27301549	Floating rubber A	38	27301559	R plate ass'y
3	880022	Plastic rivert	39	2045231310	Flat cable
5	27301550	Damper	40	27301560	Harness guide
6	27190888	Holder ass'y	41	838426068	2.6TTP+6B(BC),Self-tapping screw
7	27301551	Holder spring A	42	834430168	3TTS+16B(BC),Self-tapping screw
8	27260313	Carriage shaft (Lower)	43	870155	Washer
9	27180512	Rack spring (Lower)	44	27301561	Rack gear (Lower)
10	27301552	Carriage ass'y	45	27301562	Turntable ass'y
11	27260314	Sheet	101		Mechanism chassis
12	27301553	Yoke plate A	102	24505330	FGSB pc board ass'y
13	27301554	Centering hab A	103	24505329	CNNB pc board ass'y
14	27180507	Centering spring	105		Rubber sheet
16	801498	3×5,Screw	106		Housing ass'y
17	801492	3B+16F(Cu),Binding screw	107		Switch holder
18	801493	Sems screw	108		Housing ass'y
19	82112612	2.6P+12F,Pan head screw	109		Caution label
20	838630100	3T1B+10P(Cu),Self-tapping screw	110	24505328	PREB pc board ass'y
21	834630100	3TTS+10P(Cu),Self-tapping screw	111	24505327	PRET pc board ass'y
22	835120088	2TTF+8B,Self-tapping screw	112		Turntable ass'y
23	25065453	Slide switch (CD INSIDE) S2			
24	25065454	Slide switch (CDV,LD A INSIDE) S3			
25	801494	2P+7F(Cu),Pan head screw			
26	27180513	Holder spring B			
27	27260315	Carriage shaft (Upper)			
28	27301555	Rack gear (Upper)			
29	27301596	Mechanism chassis ass'y (Upper)			
30	27180514	Rack spring (Upper)			
31	82112016	2P+16F,Pan head screw			
32	82112008	2P+8F,Pan head screw			
33	25065454	Slide switch (LD B INSIDE) S4			
34	27301556	Internal gear ass'y			
35	27301557	G plate ass'y			
36	27180508	Lever spring			

**NOTES:**

- Parts without part number cannot be supplied.
- The components identified by mark **△** are critical for risk of fire and electric shock.  
Replace only with part number specified.

### 3.8 PACKING

#### Parts List

No.	Part No.	Description	No.	Part No.	Description
1	2010234	Connection cord	51	3010124	Battery
2	2010235	Video cable	52		Polyethylene bag
4	29341683	Instruction manual	53	29355185	Caution card
5	24140226	RC-226C Remote control unit	55	29355186	Caution card CU
6	29112022	Pad F	56		Polyethylene bag
7	29112023	Pad R	57	29358002J	Service station list
9	29052384	Master carton box	58	29365019A	Warranty card
10		Mirror mat			
11	28150206	Battery cover			
51	3010124	Battery			
52		Polyethylene bag			
53	29355185	Caution card			
55	29355186	Caution card CU			
56		Polyethylene bag			
57	29358002J	Service station list			
58	29365019A	Warranty card			

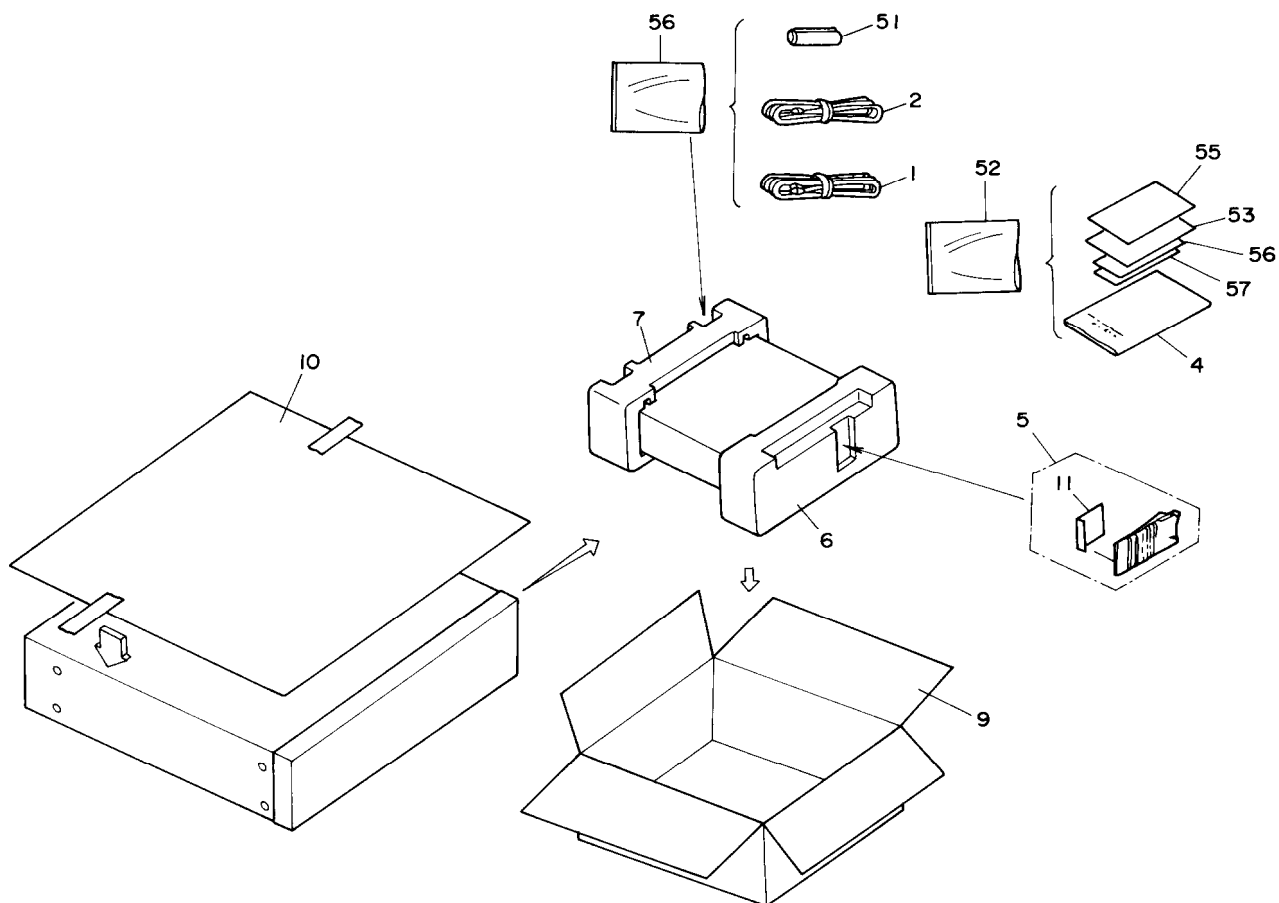

IC901  
<RD49403NT>

Pin No.	Voltage	Pin No.	Voltage	Pin No.	Voltage
1	*	15	*	29	*
2	*	16	*	30	2.5
3	*	17	*	31	2.5
4	*	18	2.5	32	*
5	0	19	2.5	33	2.5
6	*	20	*	34	2.5
7	0	21	2.5	35	5
8	*	22	*	36	*
9	*	23	*	37	*
10	0	24	2.5	38	*
11	0	25	5	39	*
12	5	26	*	40	*
13	0	27	2.5	41	*
14	0	28	*	42	*

IC902  
<NJM4558D>

Pin No.	Voltage
1	*
2	*
3	*
4	*
5	*
6	*
7	*
8	0

IC903  
<NJM4558S>

Pin No.	Voltage
1	*
2	*
3	*
4	0
5	*
6	*
7	*
8	*

IC904  
<NJM4558D>

Pin No.	Voltage
1	2.4
2	2.4
3	2.4
4	-2.4
5	0
6	0
7	0
8	0

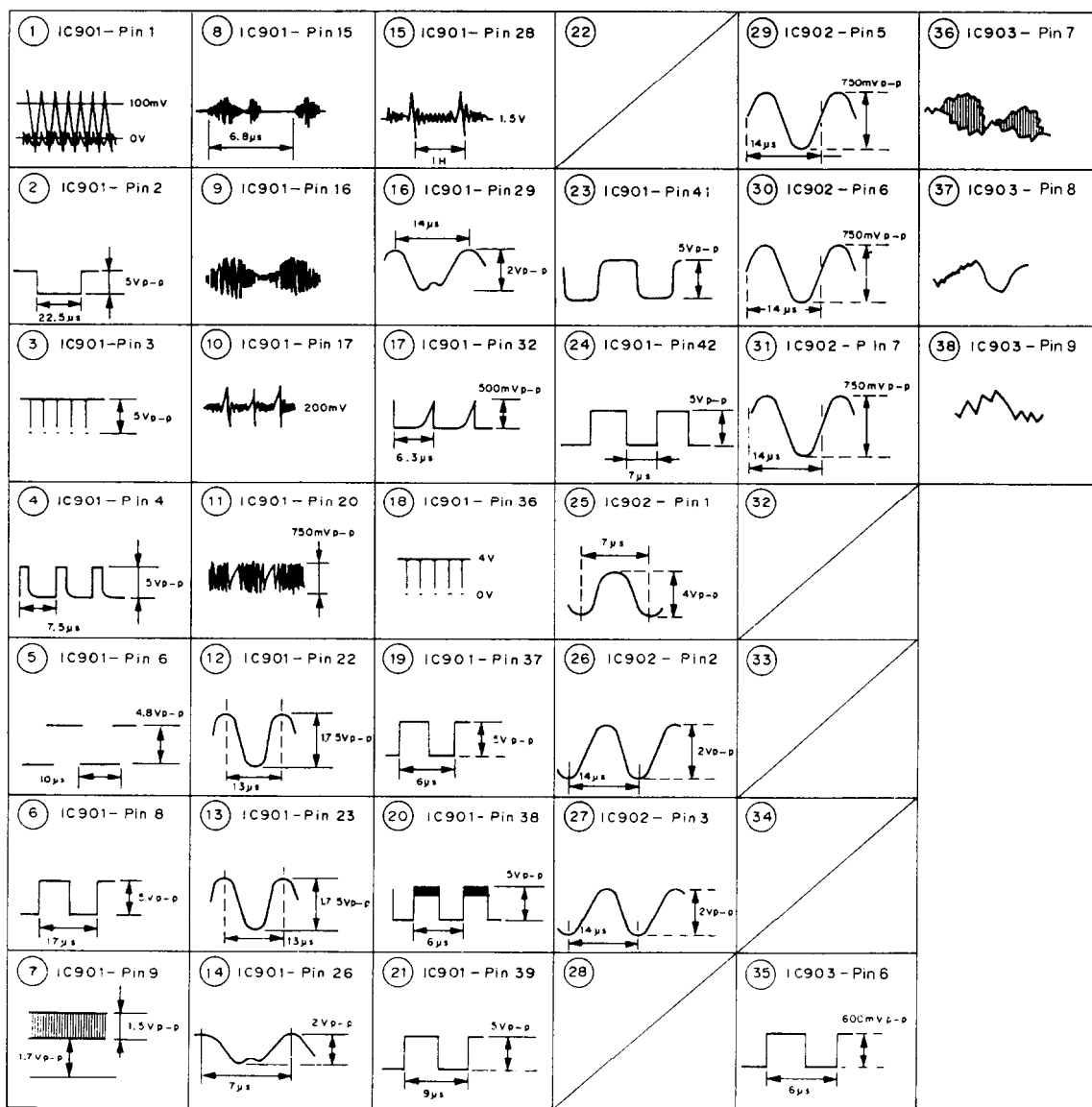

(PLAY MODE)

IC401  
<PA5010>

Pin No.	Voltage	Pin No.	Voltage	Pin No.	Voltage	Pin No.	Voltage
1	-1.2	17	0	33	*	49	-1.7
2	5	18	*	34	*	50	-1.7
3	-1	19	5	35	*	51	*
4	5	20	1	36	1	52	0
5	1	21	*	37	5	53	-2
6	5	22	*	38	*	54	5
7	5	23	-2.5	39	*	55	*
8	*	24	*	40	*	56	-2
9	5	25	*	41	*	57	*
10	*	26	*	42	*	58	*
11	5	27	0.5	43	0	59	5
12	-5	28	*	44	*	60	3.8
13	-5	29	*	45	5	61	-5
14	0	30	*	46	*	62	-3.2
15	*	31	*	47	*	63	5
16	-2	32	-5	48	-1.7	64	0.2

IC402  
<PN0001>

Pin No.	Voltage
1	-5
2	*
3	-2
4	-2
5	*
6	0
7	5
8	*

IC403  
<CXL1009P>

Pin No.	Voltage
1	*
2	4.2
3	-2
4	*
5	-3.5
6	1
7	-5
8	0
9	-5
10	4.2
11	-5
12	*
13	0
14	-5
15	0.3
16	-3.8
17	0.8
18	-2
19	4.2
20	-5

IC404  
<PA0017>

Pin No.	Voltage
1	-5
2	0
3	*
4	*
5	-5
6	*
7	-5
8	0.2

IC405  
<M50554-132SP>

Pin No.	Voltage	Pin No.	Voltage
1	0	17	0.8
2	*	18	5
3	5	19	0
4	*	20	0
5	*	21	0
6	5	22	*
7	*	23	*
8	*	24	0
9	*	25	0
10	5	26	0
11	0	27	*
12	*	28	2
13	*	29	2
14	0.6	30	*
15	3.5	31	*
16	0.6	32	5

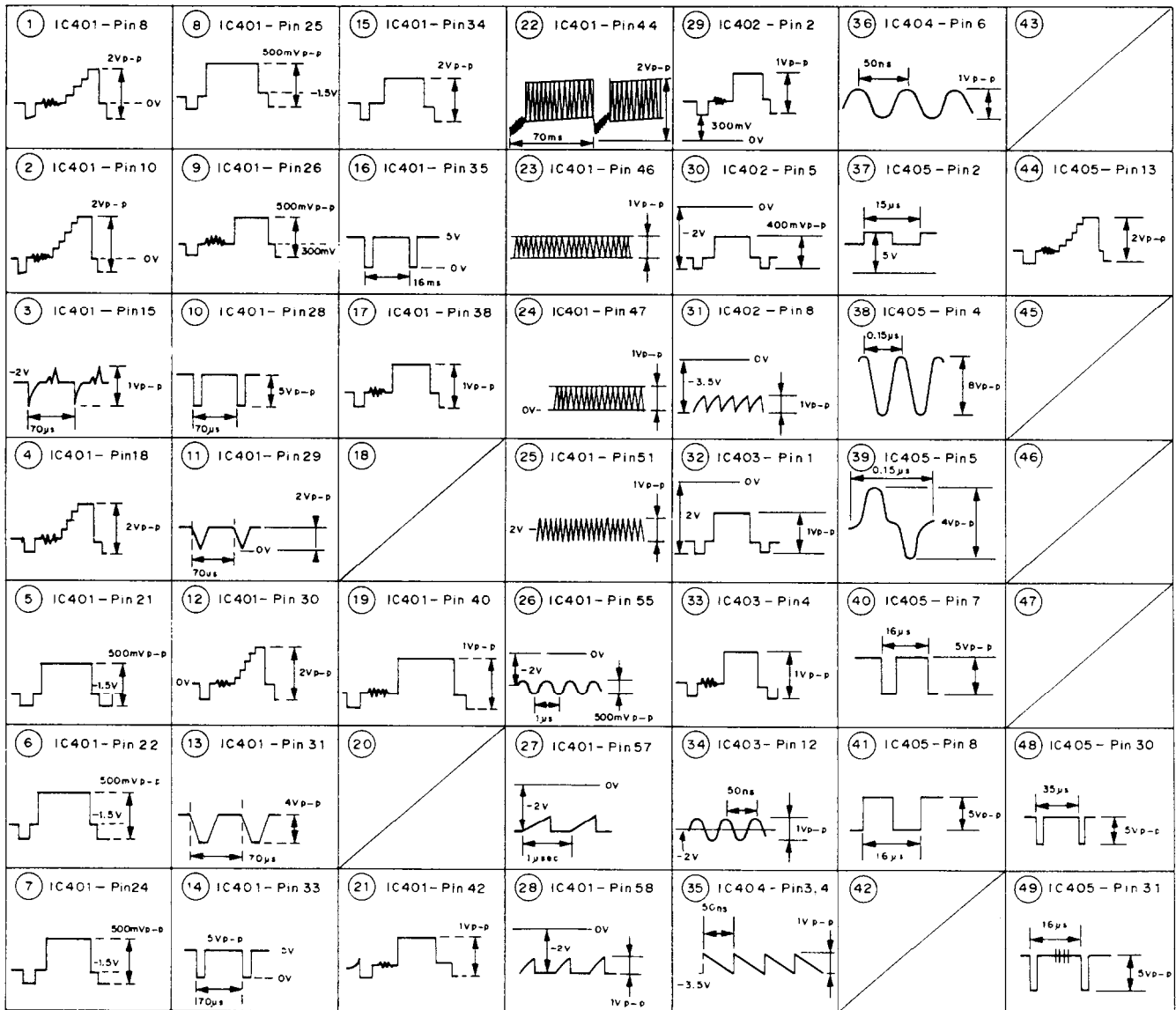

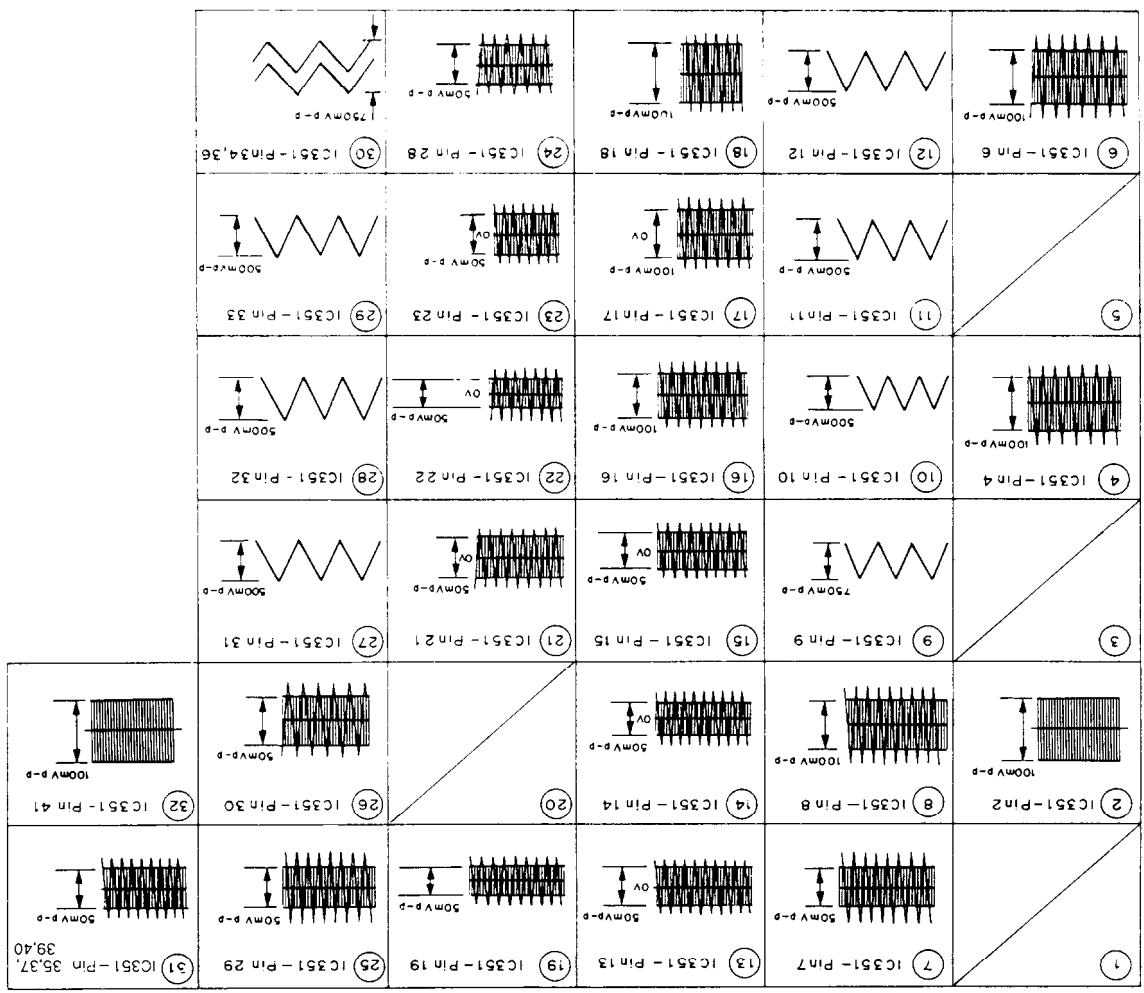

Pin No.	Pin Voltage	Pin No.	Pin Voltage	Pin No.	Pin Voltage
14	*	28	*	42	*
13	*	27	0	41	*
12	*	26	0	40	*
11	*	25	*	39	*
10	*	24	0	38	*
9	*	23	*	37	*
8	*	22	*	36	*
7	*	21	*	35	*
6	*	20	*	34	*
5	*	19	*	33	*
4	*	18	*	32	*
3	*	17	*	31	*
2	*	16	*	30	*
1	*	15	*	29	*
Pin No.	Pin Voltage	Pin No.	Pin Voltage	Pin No.	Pin Voltage
31	39.40	35	35.37	41	100mV p-p

IC351  
<PA003AA>

Mark	Circuit No.	Part No.	Description	Mark	Circuit No.	Part No.	Description
		<b>Capacitors</b>				<b>Capacitors</b>	
	C495	354780339	3.3 $\mu$ F,50V,Elect.		C917	374721234	0.012 $\mu$ F $\pm$ 5%,50V,Plastic
	C501,C519	354734709	47 $\mu$ F,10V,Elect.		C918	352932206	22 $\mu$ F,10V,Non-polar elect.
	C514	345024714	470pF $\pm$ 5%,50V,Ceramic		C919	352921016	100 $\mu$ F,6.3V,Non-polar elect.
	C521	374721044	0.1 $\mu$ F $\pm$ 5%,50V,Plastic		C922	345023314	330pF $\pm$ 5%,50V,Ceramic
	C523,C524	354734709	47 $\mu$ F,10V,Elect.		C923	371123324	3300pF $\pm$ 5%,50V,Mylar
	C530	374726834	0.068 $\mu$ F $\pm$ 5%,50V,Plastic		C924,C937	374721244	0.12 $\mu$ F $\pm$ 5%,50V,Plastic
	C531	354781009	10 $\mu$ F,50V,Elect.		C925	374722234	0.022 $\mu$ F $\pm$ 5%,50V,Plastic
	C533	354743309	33 $\mu$ F,16V,Elect.		C933	371122224	2200pF $\pm$ 5%,50V,Mylar
	C542	352932206	22 $\mu$ F,10V,Non-polar elect.		C934	374724724	4700pF $\pm$ 5%,50V,Plastic
	C549,C550	354734709	47 $\mu$ F,10V,Elect.		C950	354780109	1 $\mu$ F,50V,Elect.
	C570,C571	354734709	47 $\mu$ F,10V,Elect.		VC901	3060028	VCM008,Trimmer
	C575	352731019	100 $\mu$ F,10V,Elect.			<b>Resistors</b>	
	C601,C602	354752209	22 $\mu$ F,25V,Elect.		R403,R404	4500038	RN1/6PQ2402F
	C605,C612	374721044	0.1 $\mu$ F $\pm$ 5%,50V,Plastic		R448	4500037	RN1/6PQ1203F
	C606,C621	352941006	10 $\mu$ F,16V,Non-polar elect.		R450	4500036	RN1/6PQ1201F
	C607	371122224	2200pF $\pm$ 5%,50V,Mylar		R536	4500034	RN1/6PQ1002F
	C609	371123324	3300pF $\pm$ 5%,50V,Mylar		R632	4100011	RD1/2PMF5R6J
	C610,C615	374721244	0.12 $\mu$ F $\pm$ 5%,50V,Plastic		R961,R963	4500035	RN1/6PQ6801F
	C611	374721844	0.18 $\mu$ F $\pm$ 5%,50V,Plastic		R962,R964	4500034	RN1/6PQ1002F
	C613,C632	374724724	4700pF $\pm$ 5%,50V,Plastic		R989,R990	4500034	RN1/6PQ1002F
	C614,C630	374726834	0.068 $\mu$ F $\pm$ 5%,50V,Plastic		R992	4500035	RN1/6PQ6801F
	C616	374721044	0.1 $\mu$ F $\pm$ 5%,50V,Plastic		VR441	5215087	VRTB6VS222
	C617	345345604	56pF $\pm$ 5%,50V,Ceramic		VR481,VR482	5215088	VRTB6VS472
	C618	354781009	10 $\mu$ F,50V,Elect.		VR521	5215089	VRTG6VS472
	C619	371125614	560pF $\pm$ 5%,50V,Mylar			<b>Terminals</b>	
	C620,C625	374722234	0.022 $\mu$ F $\pm$ 5%,50V,Plastic		CN104	25050749	VKN1088
	C623,C624	354754709	47 $\mu$ F,25V,Elect.		CN105	25055623	VKN1087
	C627,C628	354754709	47 $\mu$ F,25V,Elect.			<b>PRE. AMPLIFIER TOP PC BOARD</b>	
	C629	371126824	6800pF $\pm$ 5%,50V,Mylar	Mark	Circuit No.	Part No.	Description
	C631	352984796	0.47 $\mu$ F,50V,Non-polar elect.		IC201	22240247	BA15218,IC
	C633	374723334	0.033 $\mu$ F $\pm$ 5%,50V,Plastic		Q201,Q202	2213284 or	2SC1740S-R or
	C636	352941006	10 $\mu$ F,16V,Non-polar elect.			2213285	2SC1740S-S,Transistor
	C637	374721524	1500pF $\pm$ 5%,50V,Plastic		VR201	5215085	VRTB6VS102,Semi-fixed resistor
	C638,C639	354754709	47 $\mu$ F,25V,Elect.		VR202,VR203	5215088	VRTB6VS472,semi-fixed resistor
	C640,C645	352980106	1 $\mu$ F,50V,Non-polar elect.		CN905	25050746	VKN1082,Socket
	C641,C648	371121024	1000pF $\pm$ 5%,50V,Mylar		CN906	25050747	VKN1083,Socket
	C642	345022414	240pF $\pm$ 5%,50V,Ceramic			<b>LOADING HORIZONTAL SWITCH PC BOARD</b>	
	C643	352932206	22 $\mu$ F,10V,Non-polar elect.	Mark	Circuit No.	Part No.	Description
	C644	374722234	0.022 $\mu$ F $\pm$ 5%,50V,Plastic			25065455	VSK1011,Microswitch
	C655	371122724	2700pF $\pm$ 5%,50V,Mylar			<b>LINE SURGE FILTER PC BOARD</b>	
	C675	352950476	4.7 $\mu$ F,25V,Non-polar elect.	Mark	Circuit No.	Part No.	Description
	C801,C809	354752209	22 $\mu$ F,25V,Elect.		C201,C202	3500065A	DE7150FZ103P,Capacitor
	C806	354752219	220 $\mu$ F,25V,Elect.		L201	231202	VTL-262,Coil
	C901,C941	374724734	0.047 $\mu$ F $\pm$ 5%,50V,Plastic				
	C904	354734709	47 $\mu$ F,10V,Elect.				
	C907	371128224	8200pF $\pm$ 5%,50V,Mylar				
	C908,C954	352731019	100 $\mu$ F,10V,Elect.				
	C909	374722234	0.022 $\mu$ F $\pm$ 5%,50V,Plastic				
	C912	352984796	0.47 $\mu$ F,50V,Non-polar elect.				
	C914	354780109	1 $\mu$ F,50V,Elect.				
	C916	352980106	1 $\mu$ F,50V,Non-polar elect.				



## AUDIO CIRCUIT PC BOARD ASS'Y

Mark	Circuit No.	Part No.	Description
		ICs	
IC201	22240365	CXD2500Q	
IC202	22240508	SM5840AP	
IC203	22240363	SM5860BF	
IC204	22240369	M5218AP	
IC205	222840531	4053B	
IC206	222755	TC74HCU04P	
IC207	222780053	78L05A	
IC208,IC209	22240312	NJM4580L	
IC210,IC211	22240453R1	TC4S66F	
IC213	222780083	78L08A	
IC214	222790083	79L08A	
IC351	22240513	PA0034A	
		Transistors	
Q201,Q352	2213284 or	2SC1740S-R or	
Q203-Q205	2213285	2SC1740S-S	
Q202	2213354 or	2SA933S-R or	
Q206,Q207	2213355	2SA933S-S	
Q208,Q210	2214220	RN1203	
Q209,Q211	2213580	RN2203	
Q212	2214220	RN1203	
Q213,Q214	2214280	2SD2144S	
Q351	2214260	2SC2786	
		Diodes	
D201	223204	FC54M	
D202,D205	223202	1SS254	
		Coils	
L201,L203	233415K151	LAU151K	
L202	233416J181	LAU181J	
L204	233414K018	LAU1R8K	
L351,L352	233413J560	LAU560J	
L353	233412J270	LAU270J	
		Filter	
F351	3030006	RTF1084	
		Crystal	
X201	3010186	VSS1022	
		Capacitors	
C203	354781009	10 $\mu$ F,50V,Elect.	
C204	374724734	0.047 $\mu$ F $\pm$ 5%,50V,Plastic	
C207	352941006	10 $\mu$ F,16V,Non-polar elect.	
C208	352980106	1 $\mu$ F,50V,Non-polar elect.	
C212,C215	354780109	1 $\mu$ F,50V,Elect.	
C223,C307	354780109	1 $\mu$ F,50V,Elect.	
C230,C234	391934709	47 $\mu$ F,10V,Elect.	
C243	352731019	100 $\mu$ F,6.3V,Elect.	
C245,C265	391934709	47 $\mu$ F,10V,Elect.	
C250,C252	354722219	220 $\mu$ F,6.3V,Elect.	
C254,C258	345021214	120pF $\pm$ 5%,50V,Ceramic	
C256,C257	3300016	47pF $\pm$ 5%,50V,Ceramic	
C260,C261	3300016	47pF $\pm$ 5%,50V,Ceramic	
C262,C267	374726824	6800pF $\pm$ 5%,50V,Plastic	

Mark	Circuit No.	Part No.	Description
		Capacitors	
	C263,C268	374721034	0.01 $\mu$ F $\pm$ 5%,50V,Plastic
	C264,C269	374726814	680pF $\pm$ 5%,50V,Plastic
	C266,C270	391934709	47 $\mu$ F,10V,Elect.
	C271	391934709	47 $\mu$ F,10V,Elect.
	C272,C273	352932206	22 $\mu$ F,10V,Non-polar elect.
	C274-C277	374724714	470pF $\pm$ 5%,50V,Plastic
	C284,C286	354751019	100 $\mu$ F,25V,Elect.
	C285,C287	391934709	47 $\mu$ F,10V,Elect.
	C288,C290	352731019	100 $\mu$ F,6.3V,Elect.
	C308,C309	354722219	220 $\mu$ F,6.3V,Elect.
	C355,C370	354781009	10 $\mu$ F,50V,Elect.
	C360,C369	354722219	220 $\mu$ F,6.3V,Elect.
	C361,C379	352731019	100 $\mu$ F,6.3V,Elect.
	C364,C383	354752209	22 $\mu$ F,25V,Elect.
	C367,C387	374723934	0.039 $\mu$ F $\pm$ 5%,50V,Plastic
	C368,C386	352932206	22 $\mu$ F,10V,Non-polar elect.
	C372,C373	374721044	0.1 $\mu$ F $\pm$ 5%,50V,Plastic
	C376,C378	354722219	220 $\mu$ F,6.3V,Elect.
	C388	354784799	0.47 $\mu$ F,50V,Elect.
		Terminals	
		25050749	VKN1088,Socket
		25055623	VKN1087,Plug
	J6	25045367	VKB1021,Output
	CN302	25055065	NPLG-5P51,Plug

## PRE AMPLIFIER BOTTOM PC BOARD

Mark	Circuit No.	Part No.	Description
		ICs	
	IC101	22240111	BA15218
	IC102	22240507	IR3C02A
		Capacitors	
	C104	352731019	100 $\mu$ F,10V,Elect.
	C105	355742209	22 $\mu$ F,16V,Elect.
		Resistors	
	R119	417441004	RD1/4PM100J,Carbon
	VR101-VR103	5215088	VRTB6VS472,Semi-fixed
	VR104	5215086	VRTB6VS104,Semi-fixed
		Sockets	
	CN901	25050755	VKN1079
	CN902	25050744	VKN1025
		Plugs	
	CN903	25055621	VKN1080
	CN904	25055622	VNK1081

## FG SWITCH PC BOARD

Mark	Circuit No.	Part No.	Description
	D401	24120036	GP1S51

## LOADING VERTICAL SWITCH PC BOARD

Mark	Circuit No.	Part No.	Description
		25035635	PSH1008,Microswitch

## SYSTEM POWER SUPPLY PC BOARD

Mark	Circuit No.	Part No.	Description
			ICs
△	IC101,IC102	252112	ICP-N15-0.6A
△	IC103	222780055	78M05HF
			Transistors
	Q101	2213803	2SB1238-Q
	Q103	2213354 or 2213355	2SA933S-R or 2SA933S-S
	Q104	2212600	DTA124ES
△	Q105	2213354 or 2213355	2SA933S-R or 2SA933S-S
	Q106,Q107	2213284 or 2213285	2SC1740S-R or 2SC1740S-S
△	Q108	2202530	2SB1185
△	Q109	2202555 or 2202556	2SD1762-E or 2SD1762-F
△	Q110,Q111	2202544 or 2202545	2SD1667-R or 2SD1667-S
△	Q112,Q113	2214270	2SB1134
			Diodes
△	D101,D102	22380052	S2VB20
	D103,D104	22380027	1SR35-100A
△	D105,D106	22380027	1SR35-100A
	D107	224990072	04AZ5.6-Y
	D108	224990083	04AZ24-Z
	D109,D112	223202	1SS254
	D110,D113	224990012	04AZ5.1Y
	D111,D115	224990031	04AZ7.5X
	D114,D116	223202	1SS254
△	D117-D120	223203	D1NL20
			Coil
△	L101	231203	VTL1008
			Capacitors
	C101-C104	3300017	0.01 $\mu$ F $\pm$ 20%, 25V, Ceramic
	C106,C107	354761019	100 $\mu$ F, 35V, Elect.
	C108	354751029	1000 $\mu$ F, 25V, Elect.
	C109,C123	354761019	100 $\mu$ F, 35V, Elect.
	C110,C111	354753329	3300 $\mu$ F, 25V, Elect.
	C112	354744729	4700 $\mu$ F, 16V, Elect.
	C113	354746829	6800 $\mu$ F, 16V, Elect.
	C114,C116	354724719	470 $\mu$ F, 6.3V, Elect.
	C115	352731019	10 $\mu$ F, 35V, Elect.
	C117-C119	352731019	10 $\mu$ F, 35V, Elect.
	C120	354722219	220 $\mu$ F, 6.3V, Elect.
	C121,C122	335011034	0.01 $\mu$ F $\pm$ 5%, 25V, Ceramic
	C124,C125	354781019	100 $\mu$ F, 50V, Elect.
	C126,C127	335017434	0.047 $\mu$ F $\pm$ 5%, 25V, Ceramic
			Resistors
	R120-R123	4000133	DCN1003, Fusible
△	R124	4400006	RS1PMFR51J, Metal film

## FLUORESCENT AND KEY PC BOARD

Mark	Circuit No.	Part No.	Description
			ICs
	IC11	22240606	PDB013
	IC12	22240506	PST529C
			Remote sensor
	IC13	24130006	GP1U50X
			FL tube
	V11	212112	VAW1013
			Transistors
	Q11-Q13	2213160	DTC124ES
	Q14	2214240	RN2204
	Q15	2214230	RN1202
			L.E.Ds
	D11-D13	225279	VEL1003
			Diodes
	D14-D16	223202	1SS254
			Ceramic oscillator
	X11	3010199	VSS1055
			Capacitors
	C11	355744709	47 $\mu$ F, 16V, Elect.
	C14	355741009	10 $\mu$ F, 16V, Elect.
			Resistors
	R14	49163104408	100k $\times$ 8, 1/10W, Array
	R15	49163472404	4.7k $\times$ 4, 1/10W, Array
			Switches
	S11-S37	25035643	RSG1030
			Sockets
	CN11	25050750	52151-0610
	CN13	25050751	52151-0910
	CN14	25050752	BTMK05S-1S
			Cushion
		28141168	VEB1125

## CONNECTOR PC BOARD

Mark	Circuit No.	Part No.	Description
	CN911	25050748	VKN1086

**NOTE: THE COMPONENTS IDENTIFIED BY MARK △ ARE CRITICAL FOR RISK OF FIRE AND ELECTRIC SHOCK. REPLACE ONLY WITH PART NUMBER SPECIFIED.**

## 6. PRINTED CIRCUIT BOARD-PARTS LIST

## MAIN PC BOARD

Mark	Circuit No.	Part No.	Description	Mark	Circuit No.	Part No.	Description
		ICs				Transistors	
	IC401	22240515	PA5010		Q912,Q914	2213354 or	2SA933S-R or
	IC402	22240510	PM0001			2213355	2SA933S-S
	IC403	22240501	CXL1009P		Q925	2214070R1	DTC124EK
	IC404	22240514	PA0017				diodes
	IC405	22240502	M50554-132SP		D461,D462	223202	1SS254
	IC601	22240499	HA11529NT		D481,D521	223202	1SS254
	IC602,IC604	22240034	LA6510		D601-D611	223202	1SS254
	IC603	22240033	LA6500		D612	223212	MA700
	IC605	22240247	BA15218N		D613-D615	223202	1SS254
	IC801	22240594	PD0071A		D804	224990092	HZS6.2NB2
	IC803,IC804	22240516	TA7291P		D805	224990102	HZS8.2NB2
	IC901	22240500	HD49403NT		D901,D904	223202	1SS254
	IC902,IC904	222465	NJM4558D		D905,D907	223202	1SS254
	IC903	222736	NJM4558S		D908	223202	1SS254
	IC905	22240595	NJU4053BD				Ceramic oscillator
		Transistors			X801	3010184	VSS1040
	Q401-Q403	2213354 or	2SA933S-R or				Crystal
		2213355	2SA933S-S		X901	3010187	VSS1026
	Q441,Q442	2213284 or	2SC1740S-R or				Coils
		2213285	2SC1740S-S		L401,L523	233413J560	LAU560J
	Q443	2213354 or	2SA933S-R or		L402,L403	233421J220	LAU220J
		2213355	2SA933S-S		L404,L405	233418J120	LAU120J
	Q444-Q446	2214650	2SC2412K		L441	233424J430	LAU430J
	Q481,Q522	2213354 or	2SA933S-R or		L442	233427J620	LAU620J
		2213355	2SA933S-S		L443,L561	233423J390	LAU390J
	Q482-Q486	2213284 or	2SC1740S-R or		L444	233429J471	LFA471J
		2213285	2SC1740S-S		L445,L446	233422J221	LAU221J
	Q488	2214640	2SA1037K		L484	233420J180	LAU180J
	Q521,Q622	2214650	2SC2412K		L485	233419J121	LAU121J
	Q523,Q563	2213284 or	2SC1740S-R or		L486	233421J220	LAU220J
		2213285	2SC1740S-S		L521	233418J120	LAU120J
	Q524	2214220	RN1203		L524	233430K501	LRA561K
	Q562,Q564	2213354 or	2SA933S-R or		L601,L602	233421J220	LAU220J
		2213355	2SA933S-S		L901	233425J470	LAU470J
	Q601,Q602	2214650	2SC2412K				Capacitors
	Q603-Q605	2214070R1	DTC124EK		C401,C402	354724719	470 $\mu$ F,6.3V,Elect.
	Q606,Q613	2214640	2SA1037K		C405,C406	354734709	47 $\mu$ F,10V,Elect.
	Q607	226036	UN4112		C411	354784799	0.47 $\mu$ F,50V,Elect.
	Q608,Q609	2214060R1	DTA124EK		C421	345341514	150pF $\pm$ 5%,50V,Ceramic
	Q610,Q611	2214070R1	DTC124EK		C423,C424	354734709	47 $\mu$ F,10V,Elect.
	Q612,Q614	2214060R1	DTA124EK		C448,C452	352731019	100 $\mu$ F,10V,Elect.
	Q615,Q618	2214650	2SC2412K		C450	354752219	220 $\mu$ F,25V,Elect.
	Q616	2214060R1	DTA124EK		C464	371122724	2700pF $\pm$ 5%,50V,Mylar
	Q617	2214070R1	DTC124EK		C465	374721034	0.01 $\mu$ F $\pm$ 5%,50V,Plastic
	Q619,Q910	2214250	2SK184		C470,C561	352731019	100 $\mu$ F,10V,Elect.
	Q623,Q921	2214640	2SA1037K		C483,C500	354734709	47 $\mu$ F,10V,Elect.
	Q901,Q904	2214070R1	DTC124EK		C485	354724719	470 $\mu$ F,6.3V,Elect.
	Q906,Q907	2214070R1	DTC124EK		C486	354752209	22 $\mu$ F,25V,Elect.
	Q911,Q913	2213284 or	2SC1740S-R or		C489	352980106	1 $\mu$ F,50V,Non-polar elect.
		2213285	2SC1740S-S		C490	374722244	0.22 $\mu$ F $\pm$ 5%,50V,Plastic
					C491,C492	354780339	3.3 $\mu$ F,50V,Elect.

## 7. DISASSEMBLY

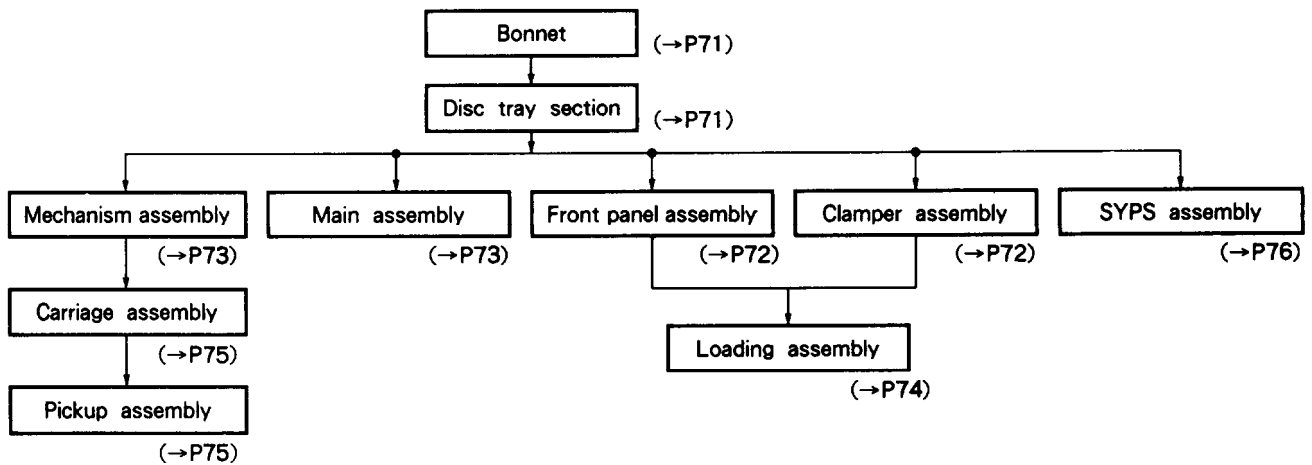

### 1. Bonnet

- ① Remove four screws **A** from the left and right side.
- ② Remove three screws **B** at the rear of the bonnet.

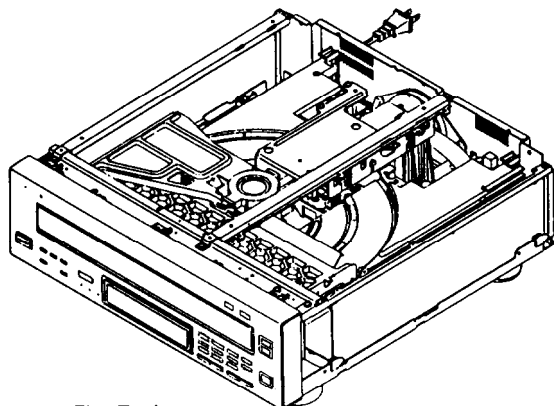
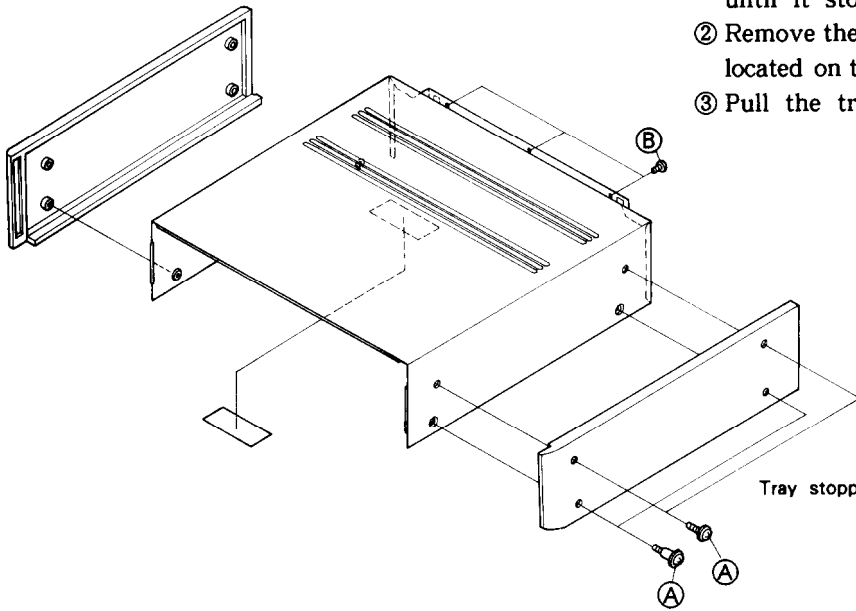

Fig. 7-1

### 2. Disc tray

Note : The bonnet should be removed first.

- ① Push the slide cam with your hand toward the front until it stops. (Have the unit's front door open.)
- ② Remove the tray stopper screw and the screw **A** located on the right front side of the clamper arm (A).
- ③ Pull the tray straight out.

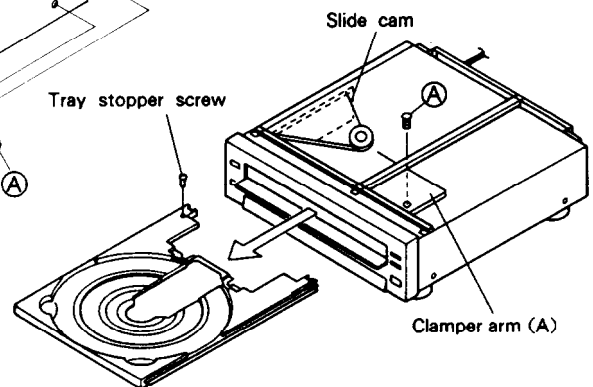

Fig. 7-2

### —How to install the disc tray—

To install the disc tray, align the synchro-gear assembly with the disc tray so that the one-tooth missing portion (red mark) of the gear is one tooth under the vertical position as illustrated below. Then, push the tray straight in.

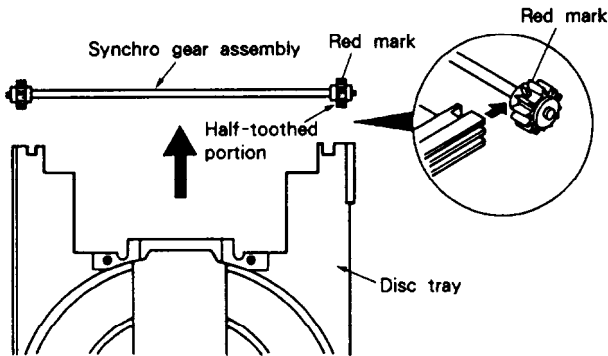

Fig. 7-3

### 3. Front panel

- ① Remove the four screws (A) from the upper side of the front panel and open in the direction of the arrow.
- ② Remove three teeth from the lower side of the front panel.

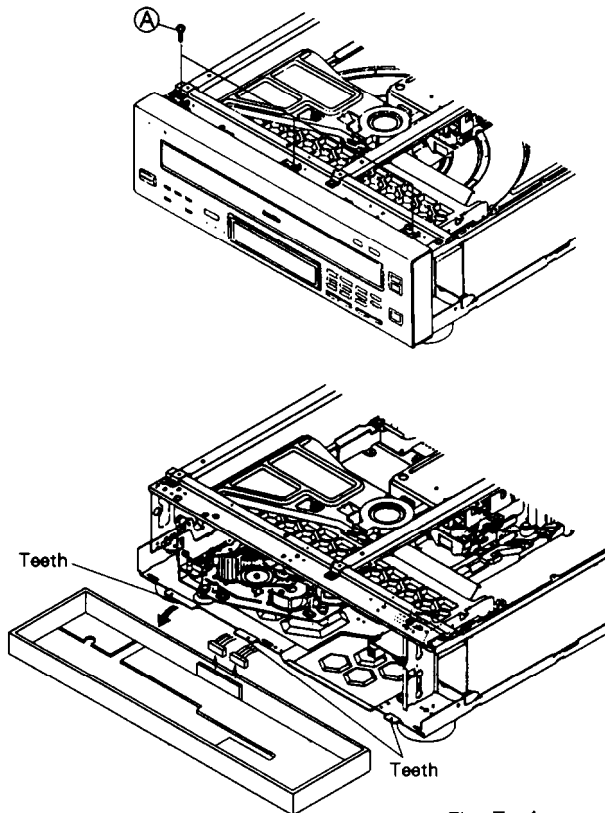

Fig. 7-4

### 4. Clamper arm (B) and (A) assemblies

- ① Remove the two clamp springs.
- ② Unscrew the clamper locking screw, and remove the clamper.
- ③ While pulling the notch located at the right side of the clamper holder toward you, detach the clamper holder from the parallel link.
- ④ Raise the clamper arm (B) assembly in the direction of the arrow.
- ⑤ Remove the carriage assembly. (→P75)
- ⑥ Remove the washer (A), washer (B) and nylon washer from the right side of the clamper arm (A) assembly, and the locking screw and the arm spring from the left side.

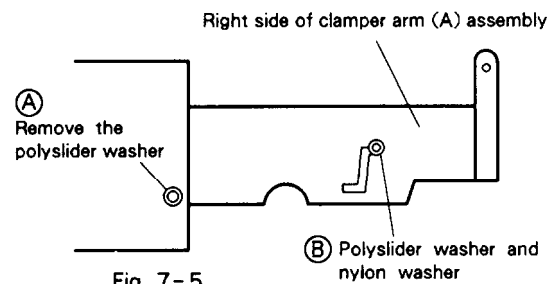

Fig. 7-5

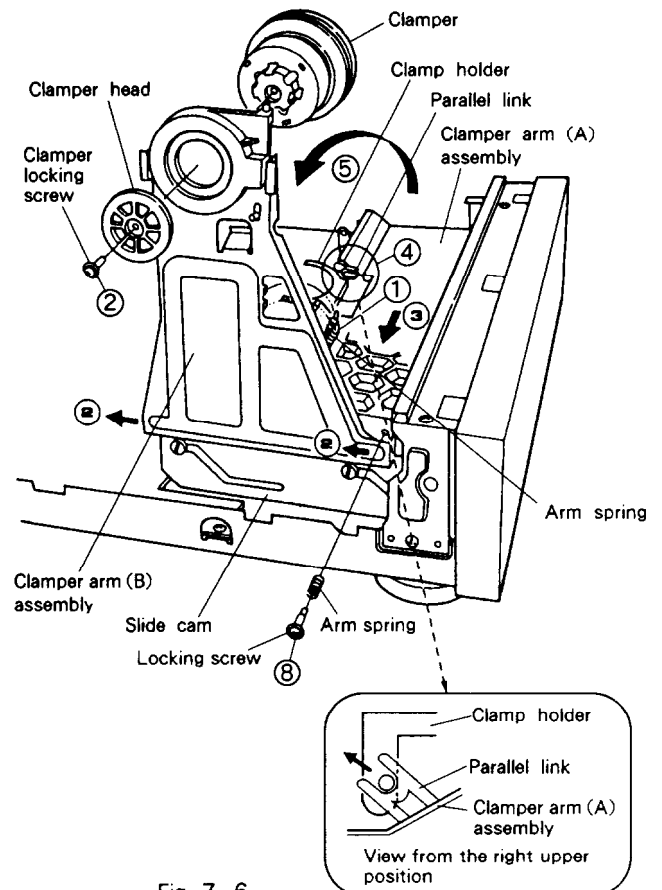

Fig. 7-6

### Clamper section mounting

- ① Insert the left pin of the clamp holder into the left claw of the parallel link.
- ② Insert the right pin of the clamp holder into the right claw in the same way.

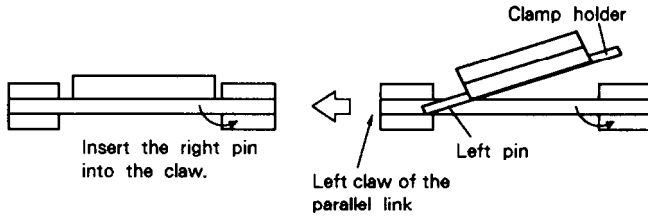
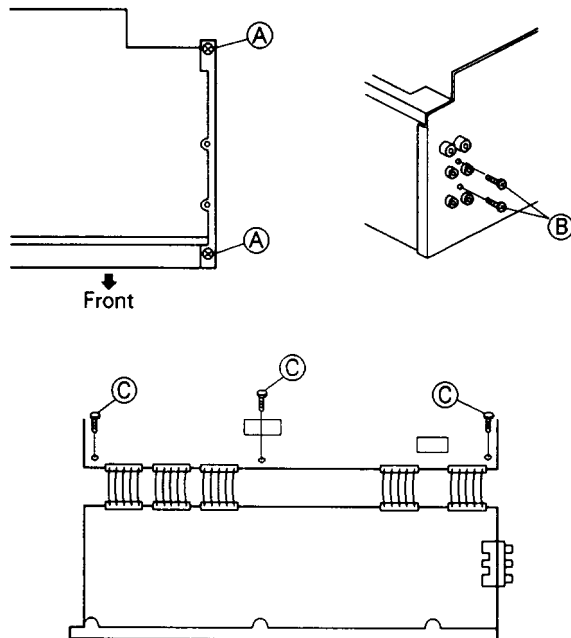

Fig. 7-7

### 5. MAIN Assembly

Note : The bonnet should be removed first.

- ① Remove two screws (A) from the PCB holder.
- ② Remove two screws (B) from the rear panel.
- ③ Remove three screws (C) from the MAIN assembly.



### 6. Mechanism assembly

Note : The bonnet should be removed first.

- ① Remove the disc tray. (→P71)
- ② Remove the CN108 from the SYPS assembly, and also remove the CNNB assembly and the flexible cable from the MAIN assembly.
- ③ Remove the three locking screws from the mechanism assembly. Pull out the mechanism assembly by lifting its rear side.

Note : Completely remove the two front locking screws from the mechanism assembly.

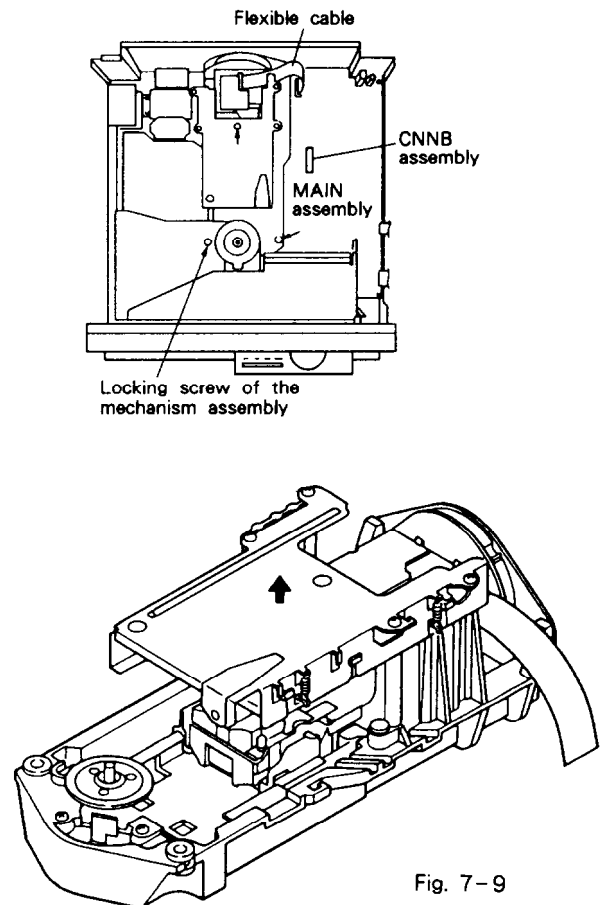

Fig. 7-9

### Diagnosis of the MAIN assembly

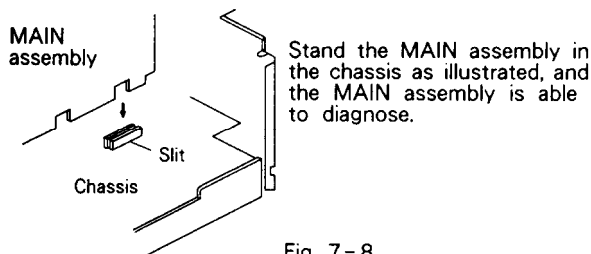

Fig. 7-8

## 10. Tilt motor

Note: The carriage assembly should be removed first.

- ① Disconnect the tilt motor connector.
- ② Remove the screw fixing the tilt motor assembly -S and the carriage assembly from the bottom of the carriage assembly.

## 11. Height motor

Note: The pickup and tilt motor assemblies should be removed first.

- ① Disconnect the height motor connector.
- ② Remove one screw which attaches the height motor assembly and the carriage assembly.

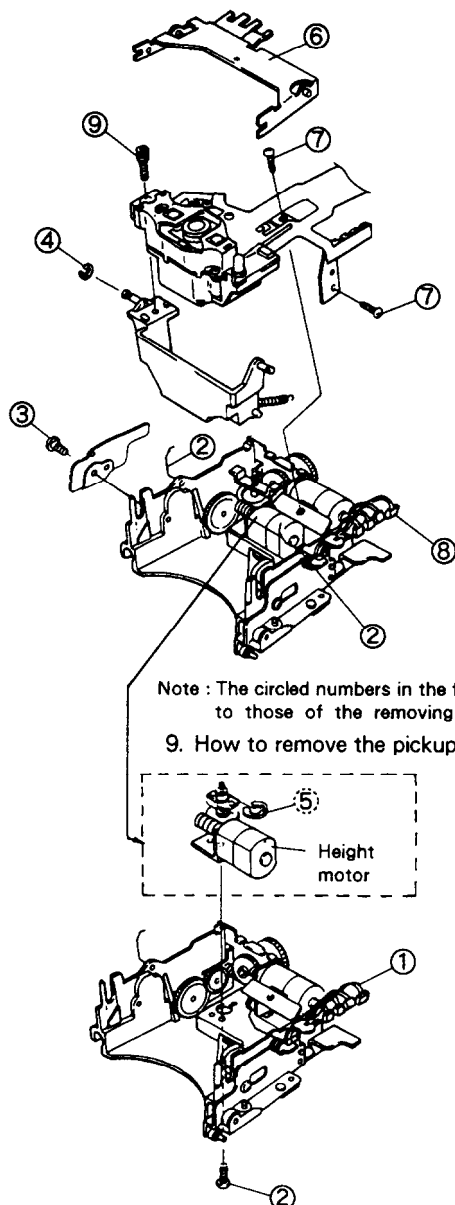

Fig. 7-16 How to remove the height motor

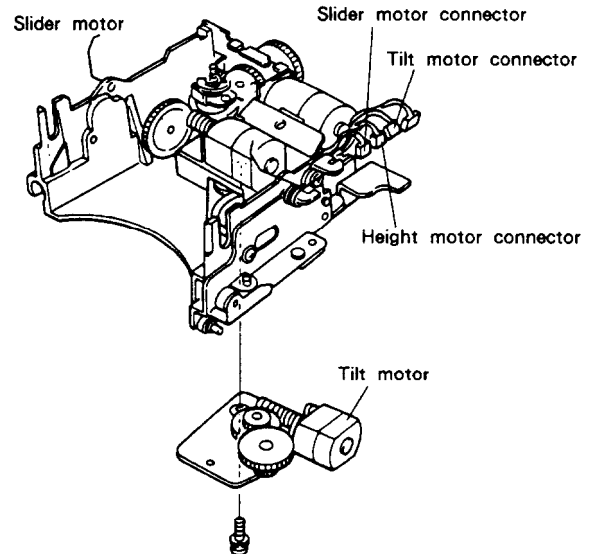

Fig. 7-17

10. How to remove the tilt motor
12. How to remove the slider motor

## 12. Slider motor

Note: The pickup assembly, AF motor assembly and the tilt motor assembly should be removed first.

- ① Disconnect the slider motor connector.
- ② Remove the harness wrapped around the slider base.
- ③ Remove the two screws fixing the slider motor.

## 13. SYPS assembly

Note: The bonnet should be removed first.

- ① Remove a screw (A) fixing the P.C. board.
- ② Remove the two screws (B) fixing the heat sink of left side of the player.
- ③ Remove the two PCB supports (C).

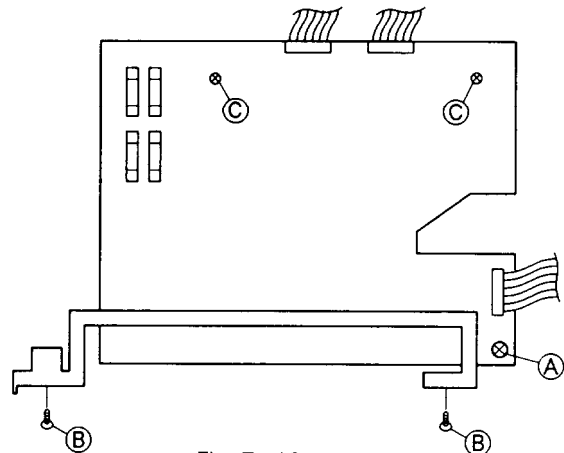

Fig. 7-18



### 7. Loading assembly

(Remove the loading assembly only when the motor is replaced. Gears can be removed from the top.)

**- How to install the cam gear -**

Set all the switches on the LVSB assembly to ON and install the cam gear with the ▽ mark pointing to the front.

	SW1 V POS 0	SW2 V POS 1	SW3 V POS 2
Side A playback position	0	0	0
Side B clamp position	0	0	1
Door open position	1	0	1
Side B → Side A	1	1	0
Carry up	1	1	1

1 = ON 0 = OFF

Table :Switch position and the status of the unit  
(SW1 to 3 are named in this manual for convenience.)

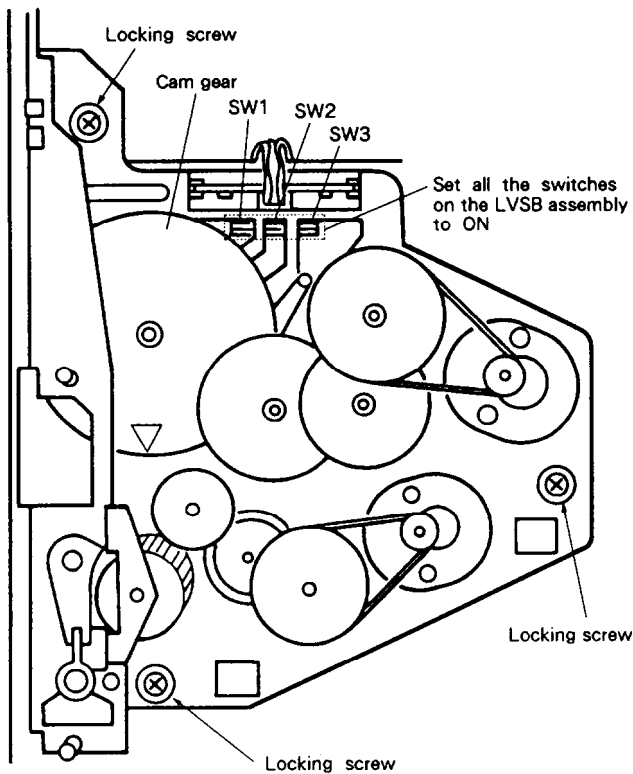

Fig. 7-10 How to instal the cam gear

**- How to install the slide cam -**

- ① Align the ▽ mark of the cam gear and the half-toothed gear of the slide cam.
- ② Fix the slide cam with the locking screw.
- ③ Fully pull out the slide cam in the front direction and fix the roller plate (L) to the slide cam with two screws.

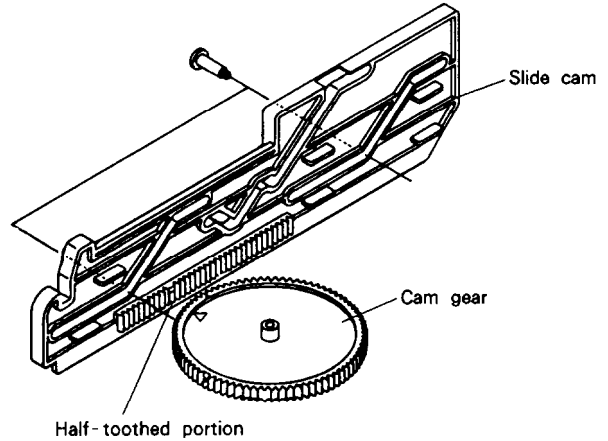

Fig. 7-11 Alignment of the cam gear and the slide cam



## 8. Carriage assembly

Note 1 : In this section, the R plate, G plate and the internal gear assembly are together called the "turn plate".

Note 2 : The mechanism assembly should be removed first.

① Move the carriage assembly toward the shaft of the turn plate.

– How to move the carriage assembly –

Move the carriage assembly by pushing its end near the slider shaft gently by hand, or by connecting a 1.5V battery to the slider motor connector.

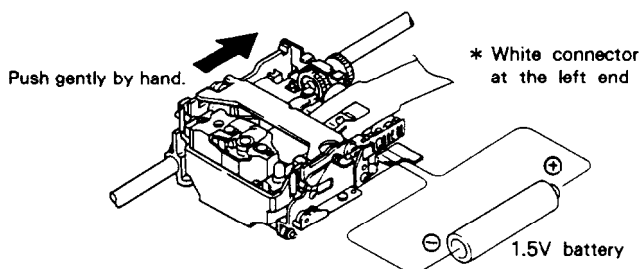

Fig. 7-12 Move the carriage assembly

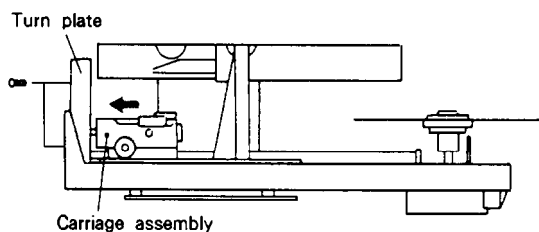

Fig. 7-13 Carriage assembly turn position

- ② Disconnect the flexible cable which connects the PREB and MAIN assemblies from the CN901 of the PREB assembly
- ③ Disconnect the flexible cable which connects the pickup assembly and the PREB assembly from the CN902 of PREB assembly.
- ④ Remove the three screws from behind the turn plate assembly.
- ⑤ Remove the carriage assembly together with the turn plate from the mechanism assembly.
- ⑥ Remove the carriage assembly from the turn plate.
- ⑦ Disengage the flexible cable from the flexible cable guide on the back of the PREB assembly. Take care not to expose the unit to static electricity.

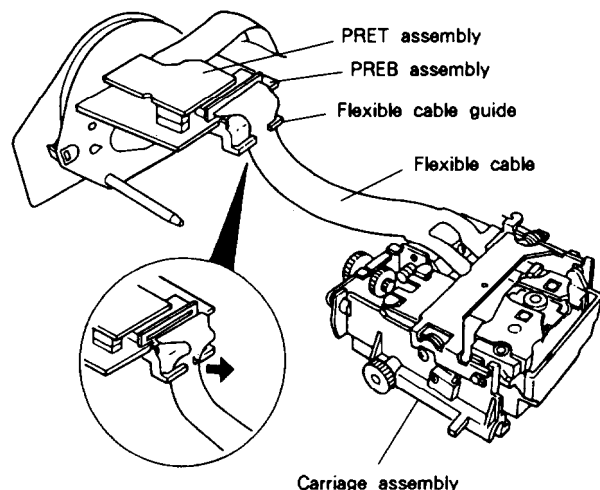

Fig. 7-14

## 9. Pickup assembly

Note : The carriage assembly should be removed first.

- ① Check that the AF plate assembly is in the middle or bottom position of the shaft of the AF gear assembly. If not, connect the battery to the AF motor connectors to make the shaft of the AF gear assembly rotate until the AF plate assembly comes to the middle or bottom of the shaft.
- ② Remove the height springs on both sides on the height side.
- ③ Remove the AF stopper locking screw.
- ④ Remove the E-ring for holding pins from the pickup holder assembly.
- ⑤ Remove the E-ring from the AF plate assembly.
- ⑥ While slightly lifting the AF arm on the AF gear assembly side, slide the AF arm and remove it.
- ⑦ Remove the two pickup connector locking screws.
- ⑧ Remove all four connectors from the connector board on the flexible cable.
- ⑨ Remove the pickup locking screw.

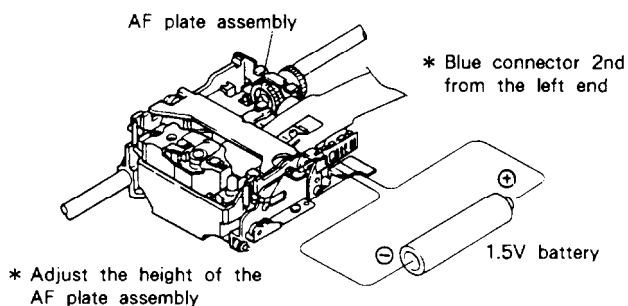
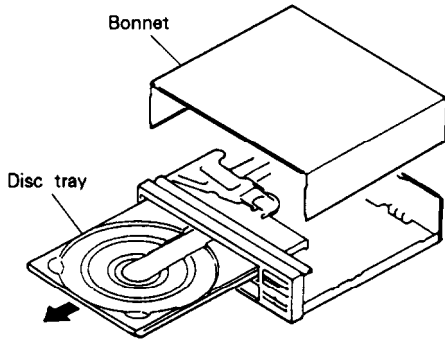

Fig. 7-15

## 8. TEST MODE

### 8.1 Test Mode

The player has a test mode function which allows the user to check the player's status on the TV screen by executing the respective key operation. Also, since the TRK servo opens and closes easily, the test mode is especially useful for mechanical adjustments.



Remove the bonnet and the disc tray.

### 8.3 Test Mode Cancellation

Turn off the power switch.

### 8.4 Player Operation in the Test Mode

Operate the player by selecting a test mode function with the keys on the player or on the remote control unit.

[Sample key Operation]

< LD Mode > Disc playback (Normal playback)  
(In the test mode)

Disc placement → → →

Note: In the test mode, disc playback will start with the TRK servo open.

< CD Mode > Disc playback (Normal playback)  
(In the test mode)

Disc placement → → → →

Note: In the test mode, disc playback will start with the TRK servo open.

### 8.2 Test Mode Initiation

[Procedure]

1. Remove the bonnet and the disc tray.
2. Load the 8-inch LD test disc on the turntable.
3. Press the slide cam to the direction of arrow mark by your hand.
4. Connect the CN303 (TEST) MAIN assembly to GND (ground).
5. Turn on the power switch.
6. Check if all the items on the FL tube are ON.
7. Disconnect the TEST TP.

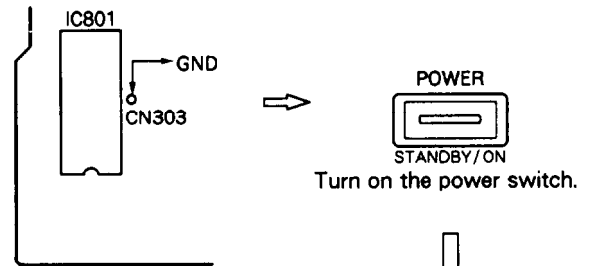

Connect CN303 to ground.



While in the test mode, all items on the FL tube will light.

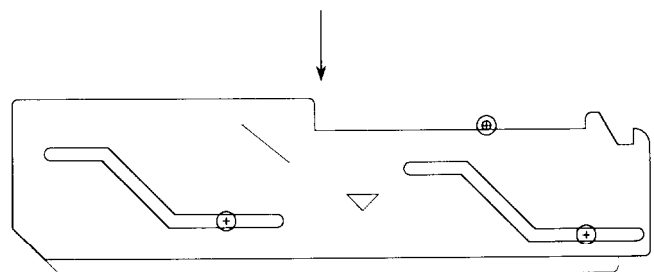
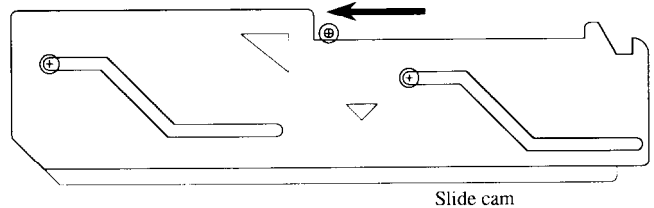

The disc will be clamped.

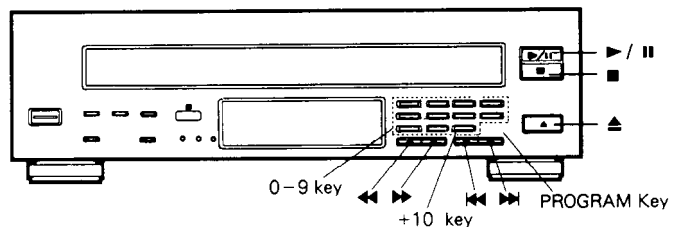

Function	Player Status	Key Operation	Remarks
Open Tray	Stop mode.	▲	
Close Tray	Tray open.	▲	
Stop	Play mode.	■	
Play	Disc placement and tray closed.	▶	<ul style="list-style-type: none"> <li>Starts up with the TRK servo open.</li> <li>Starts up with tilt neutral.</li> <li>The disc type (LD/CD/CDV) is determined when playback starts at the SLDR position during startup.</li> </ul>
TRK Servo Open/Close	Play mode.	▶	<ul style="list-style-type: none"> <li>Each time the PLAY button (▶) is pressed, the TRK servo will open or close.</li> </ul>
Still	Play mode. TRK servo closed.	 (Remote control unit key)	<ul style="list-style-type: none"> <li>Each time the STILL button (  ) is pressed, the player will switch between the PLAY and STILL modes.</li> </ul>
SLDR REV SCAN	Play mode.	◀◀	<ul style="list-style-type: none"> <li>Press and hold down the key.</li> <li>With the TRK servo open, the pickup can be damaged if the SLD moves further inward than the lead-in area on the disc. Do not allow the SLD to move further inward than the lead-in area.</li> </ul>
SLDR FWD SCAN	Play mode.	▶▶	<ul style="list-style-type: none"> <li>Press and hold down the key.</li> <li>With the TRK servo open, the pickup can be damaged if the SLD moves further outward than the lead-out area on the disc. Do not allow the SLD to move further outward than the lead-out area.</li> </ul>
TILT Servo On	Play mode.	RANDOM PLAY	
Height Minus TILT Servo OFF	Play mode.	◀◀	<ul style="list-style-type: none"> <li>Press and hold down the key.</li> </ul>
Height Plus TILT Servo OFF	Play mode.	▶▶	<ul style="list-style-type: none"> <li>Press and hold down the key.</li> </ul>
Screen Display ON/OFF	Power switch ON.	PGM key	
Frame Search	Play mode.	+10 key ↓ 0-9key ↓ ▶	<ul style="list-style-type: none"> <li>In the PLAY mode, press the +10 key. (The player will standby for the frame no. entry.)</li> <li>Use the numeric keys to enter the frame no. Then press the player's PLAY key to search.</li> <li>After the search is completed, the player will return to the operation mode before the search was performed.</li> </ul>
LOAD Motor Rotation Clockwise Counterclockwise	Tray open.	▶▶ ◀◀	

Table. Operation in test mode.

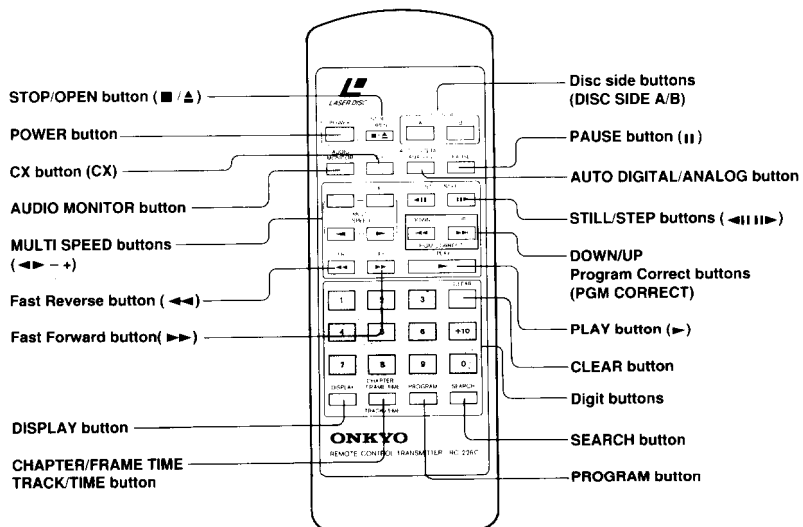

### 8.5 TV Screen and FL Tube Display in the Test Mode

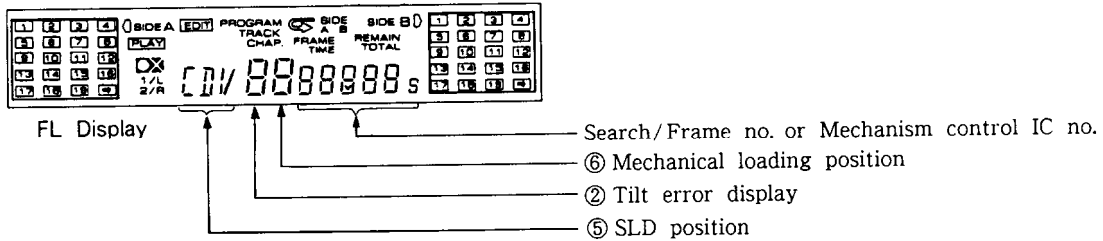
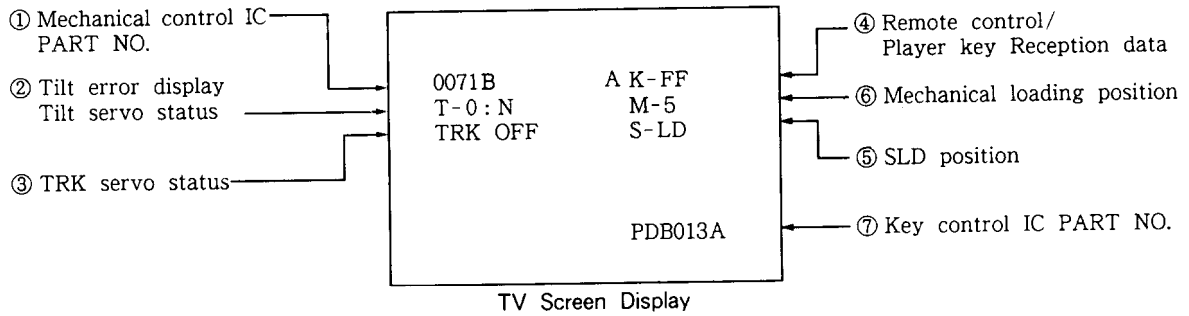

Note: The numbers in the figures above correspond to the numbered descriptions that follow.

① The mechanical control IC (MAIN assembly IC801) part no. will be displayed.  
PD0071B → 0071B

② Tilt servo status/Tilt error display  
TV screen display

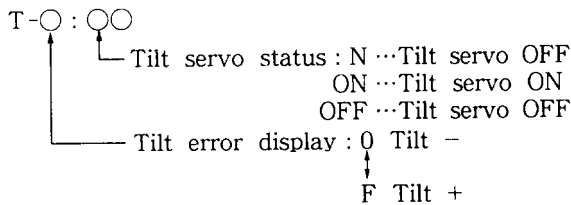

③ TRK Servo Status  
TV screen display

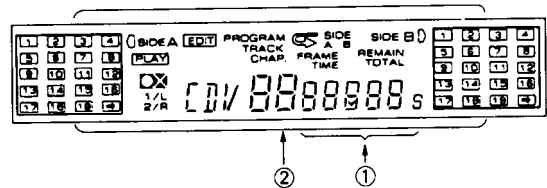
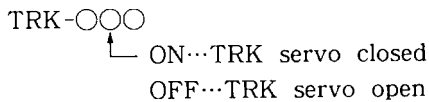

④ Remote Control/Player Key Reception Data  
TV screen display  
K-○○

See table below

CODE	FUNCTION	CODE	FUNCTION	CODE	FUNCTION	CODE	FUNCTION	CODE	FUNCTION	CODE	FUNCTION
00	0	10	F-SCAN	20		30	(10)	40	(CHAPT)	50	R-STEP
01	1	11	R-SCAN	21		31	(11)	41	(FRAME)	51	
02	2	12		22		32	(12)	42	CHP/FRM	52	F-SKIP
03	3	13	CHP/FRM	23		33	(13)	43	SEARCH	53	R-SKIP
04	4	14		24		34	(14)	44	DISPLAY	54	F-STEP
05	5	15		25		35	(15)	45	CLEAR	55	R-MULTI
06	6	16	STP/OPN	26		36	OPN/CLS	46	SPEED -	56	
07	7	17	PLAY	27		37	STOP	47	SPEED +	57	
08	8	18	PAUSE	28		38	PLY/PAS	48	REP-A	58	F-MULTI
09	9	19		29		39	EDIT	49	(2/RCH)	59	
0A		1A	(POWON)	2A		3A	INTRO	4A	(STEREO)	5A	
0B		1B	(POWOFF)	2B		3B	RANDOM	4B	(1/LCH)	5B	
0C	DGT/ANL	1C	POWER	2C		3C		4C	PROGRAM	5C	
0D		1D		2D		3D		4D		5D	
0E	CX	1E	AUD.MON	2E		3E		4E		5E	(TEST)
0F	TV/LDP	1F	+10	2F		3F		4F		5F	(ESC)

⑤ SLD Position  
TV screen display

S-○○○

- IN..... CD TOC area
- CD..... CD active area
- CDV ... CDV active area
- LD ..... LD active area

FL Display



⑥ Mechanical Loading Position  
TV screen display

M-○

- 0...Tray open
- 1...Loading
- 2...Standing by
- 3...Clamped
- 4...
- 5...

FL Display

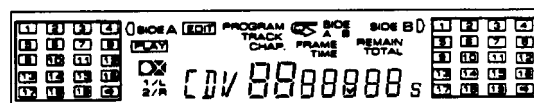

## 9. ADJUSTMENT

### 9.1 JIGS AND INSTRUMENTS REQUIRED FOR ADJUSTMENT

- Small  $\ominus$  screwdriver (about 7 cm long)
- Small Phillips head screwdriver (at least 15 cm long)
- Hexagonal wrenches (2.0 mm and 2.5 mm)
- Low-pass filter (100k ohms +  $1\mu\text{F}$ )
- Dual-trace oscilloscope (with delay)
- AF oscillator
- Frequency counter
- LD test disc (GGV1003)
- LDD disc (buy locally)
- CD test disc (YEDS-18)
- Shorting clip
- L-shaped eccentric screwdriver

### 9.2 PREPARATIONS FOR ADJUSTMENT AND PRECAUTIONS

#### 1) When replacing the pickup assembly, adjust in the following way :

– Carriage assembly in forward state –

1. Coarse grating adjustment, tracking balance adjustment
2. Crosstalk adjustment
  - 1) Adjustment of inclination of the pickup in the tangential direction and tilt servo balance adjustment
  - 2) LD focus error balance adjustment
3. Spindle motor eccentricity check
4. Spindle motor eccentricity adjustment
5. Fine grating adjustment
6. RF gain adjustment
7. FOCS servo loop gain adjustment
8. TRKG servo loop gain adjustment

– Carriage assembly in reverse state –

9. Centering adjustment for side B play
10. Pickup tangential direction angle adjustment for side B play
11. Fine centering adjustment for side B play

Note: The forward status of carriage assembly is when the carriage assembly is in the position to play side A of the disc. The reverse status is when it is in the position to play side B of the disc.

#### 2) Adjust the height of the turntable when the spindle motor is replaced.

Carriage assembly forward state

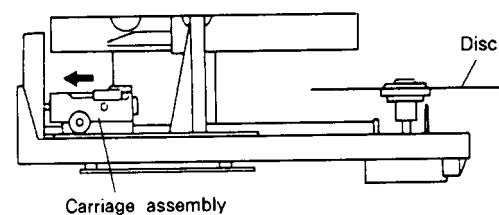

Carriage assembly reverse state

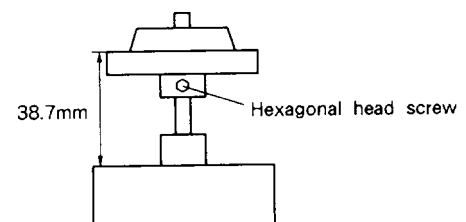
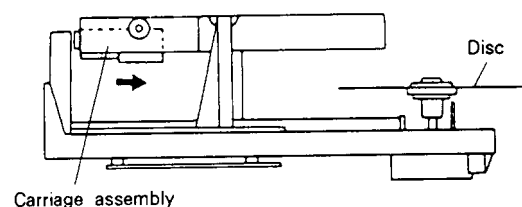

Loosen the hexagonal head screw and measure the height with a caliper. Then retighten the screw.

Turntable height adjustment

### 3) Precautions when reversing the carriage assembly

- The carriage assembly cannot be reversed unless it is advanced by playing a disc.
- If the power switch is turned OFF with the carriage assembly reversed, the backup power supply functions to resume the forward status of the carriage assembly.

### 4) Where to insert the screwdriver when adjusting the pickup assembly

– Carriage assembly in forward state –

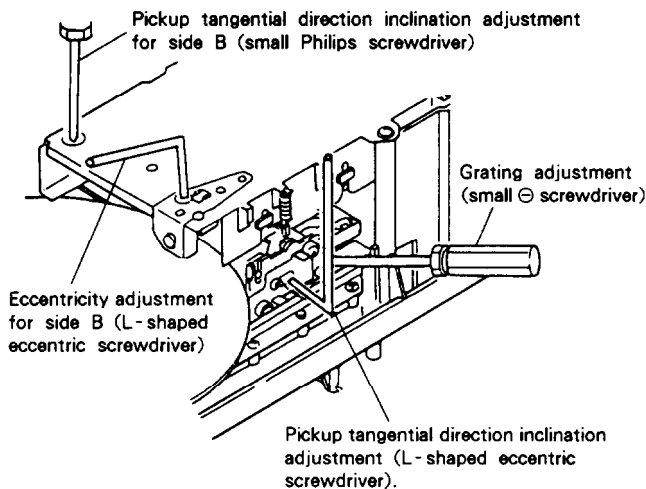

### 5) Abbreviation in the text indicate the following

FOCS	=	Focus
TRKG	=	Tracking
SPDL	=	Spindle
SLDR	=	Slider
TAN	=	Tangential

6) Numbers given in connection diagram correspond to those in the text covering the adjustment procedure.

7) Frame numbers are not displayed on the monitor TV, please read the FL display.

## 9.3 MECHANICAL ADJUSTMENT

### 1. Coarse Grating and Tracking (TRKG) Balance Adjustment

Mechanical Adjustment

- Purpose : To adjust the laser beam which is divided into three by the grating to the optimum position on the track. Set the TRKG servo offset voltage to 0V.
- When not properly adjusted : Disc playback will be impossible. During play, tracks may be skipped.

● Measuring instruments and jigs :

- Measuring point :
- Test disc and player mode

● Positions to be adjusted

● Small ⊖ screwdriver (flat blade) ● Oscilloscope

- PREB assembly TP2-2 (TRKG error)
- 8-inch LD test disc GGV1003...#6,500 ● Still mode
- Test Mode (TRKG servo : Open)
- The carriage assembly should be in the forward state.
- Grating ● PREB assembly VR101 (TRKG balance)

#### Connection diagram

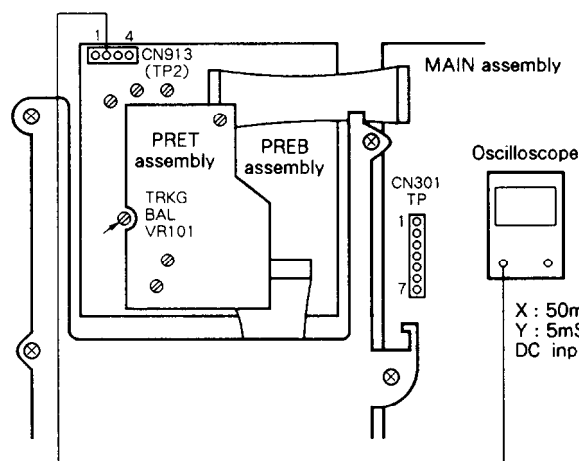

5. Connect an oscilloscope to TP2-2 in the PREB assembly.

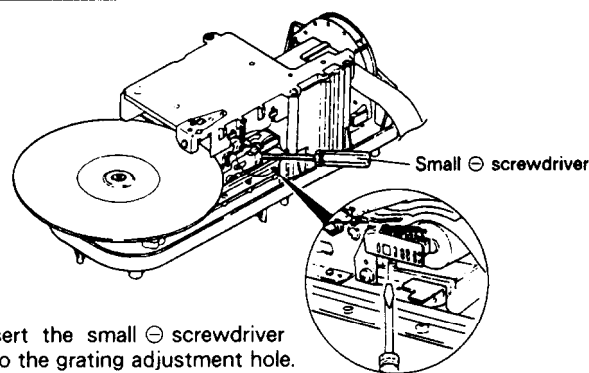

6. Insert the small ⊖ screwdriver into the grating adjustment hole.

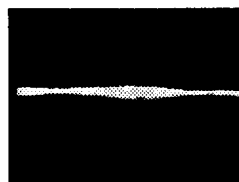

Photo 1 On-track position

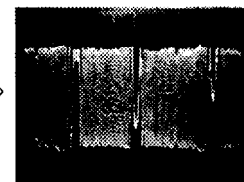

Photo 2 Maximum amplitude  
A = B

#### Adjustment Procedure

< Coarse Grating Adjustment >

1. Play the LD test disc.
2. Press the DISPLAY key to display the frame # (No.) on the TV screen.
3. Move the pickup to frame #6,500 (#300) by scanning or searching.
4. Open the TRKG servo. (See page 80)
5. Connect an oscilloscope to TP2-2 in the PREB assembly and observe the waveform.
6. Insert the small ⊖ screwdriver into the grating adjustment hole. Turning the grating will allow you to vary the amplitude of the TRKG error waveform. Find the position where the waveform amplitude becomes minimum with a smooth envelope. (Photo 1) (This indicates that the 3-way split laser beams are directed onto the track. This is called the "on-track" position.)

7. Slowly turn the grating counterclockwise from the on track position until the waveform amplitude becomes maximum. (Photo 2)
8. Close the TRKG servo and check that a normal picture is displayed on the TV screen.

< TRKG Balance Adjustment >

1. Align the oscilloscope GND so that it comes to the center of the oscilloscope screen.
2. Adjust VR101 in the PREB assembly so that the positive and negative amplitude of the TRKG error waveform become equal. (Photo 2)



## 2. Crosstalk Adjustment

### (1) Pickup Tangential Direction Angle Adjustment and Tilt Servo Balance Adjustment

(Pickup TRKG direction angle adjustment)

Mechanical Adjustment

- Purpose : To adjust the pickup tangential direction angle so as to minimize crosstalk.
- When not properly adjusted : Noticeable crosstalk will appear.

- Measuring instruments and jigs :
- Measuring point :
- Test disc and player mode
- Positions to be adjusted

- TV monitor
- L-shaped eccentric screwdriver
- Oscilloscope
- Crosstalk on the screen
- 8-inch LD test disc GGV1003...#115
- Still mode
- Test Mode (TRKG servo : Open/Close)
- The carriage assembly should be in the forward state.
- Pickup tangential direction angle adjustment screw
- PREB assembly VR103 (TILT gain) and VR104 (TILT balance).

#### Connection diagram

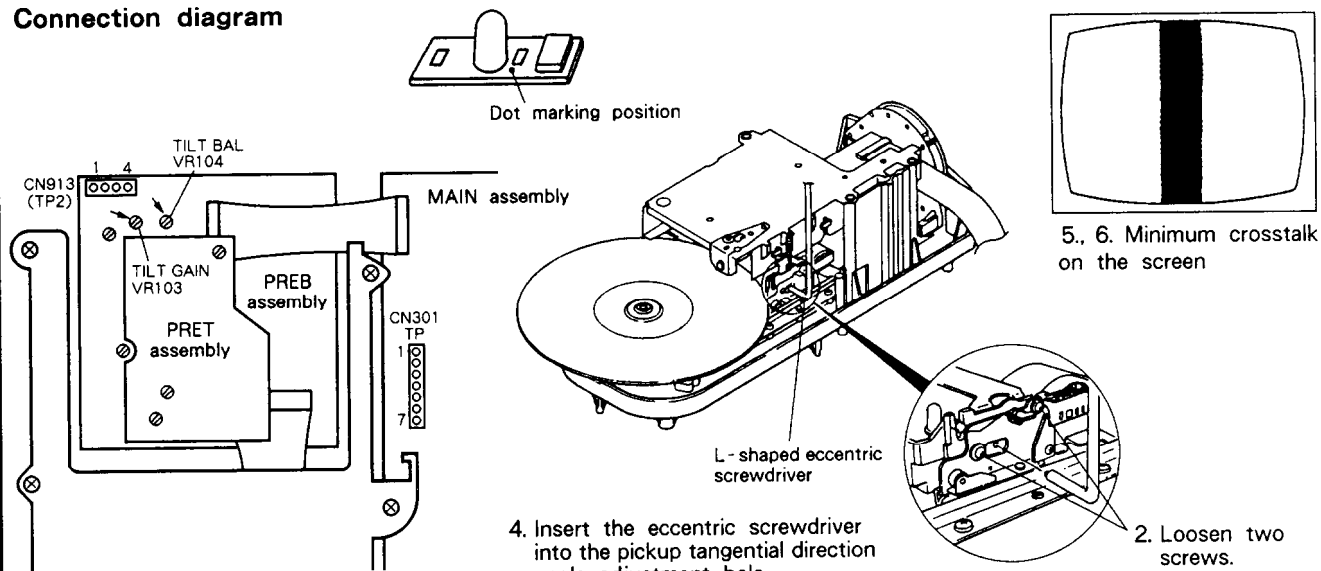

#### Adjustment Procedure

1. Check the color of the dot marked on the top of the tilt sensor, at the side of the post.  
Some players have red and blue dots. According to the color of the dot, adjust the PREB assembly VR103 as follows :  
Red dot : Turn VR103 fully counterclockwise.  
Blue dot : Turn VR103 fully clockwise.  
No dot : Set VR103 to the center position.

#### —Pickup Tangential Direction Angle Adjustment—

2. Loosen the two locking screws shown in the figure.
3. Play the 8-inch LD test disc, and search frame #115.
4. Insert the eccentric screwdriver into the pickup tangential direction angle adjustment hole.
5. While watching the TV monitor screen, adjust the pickup tangential direction angle adjustment screw so that the crosstalk on the TV screen becomes minimum.

#### —Tilt Servo Balance Adjustment—

##### (Pickup TRKG Direction Angle Adjustment)

6. In the condition in 5, adjust VR104 in the PREB assembly so that the crosstalk on the TV screen becomes minimum or the left and right halves become equal. (Turn VR104 to alter the tilt of the pickup assembly TRKG direction.)
7. If there is still noticeable crosstalk on the TV screen, repeat adjustment steps 5 and 6.
8. After adjustment is complete, tighten the two locking screws.

Note : When the pickup tangential angle is changed in the side A play mode, be sure to perform "3. Spindle Motor Centering Check", "9. Centering Adjustment for Side B Play" and "10. Pickup Tangential Direction Angle Adjustment for Side B Play".

**(2) LD FOCS Error Balance Adjustment****Mechanical Adjustment**

- Purpose : To ensure that the FOCS servo maintains the objective lens at the optimum distance from the disc surface.
- When not properly adjusted : Crosstalk will be generated.

- |  |   |
|--|---|
| <ul style="list-style-type: none"> <li>● Measuring instruments and jigs :</li> <li>● Measuring point :</li> <li>● Test disc and player mode</li> <li>● Positions to be adjusted</li> </ul> | <ul style="list-style-type: none"> <li>● TV monitor</li> <li>● Video signal output terminal</li> <li>● 8-inch LD test disc GGV1003...#115</li> <li>● Still mode</li> <li>● The carriage assembly should be in the forward state.</li> <li>● PRET assembly VR202 (FOCS balance)</li> </ul> |
|--|---|

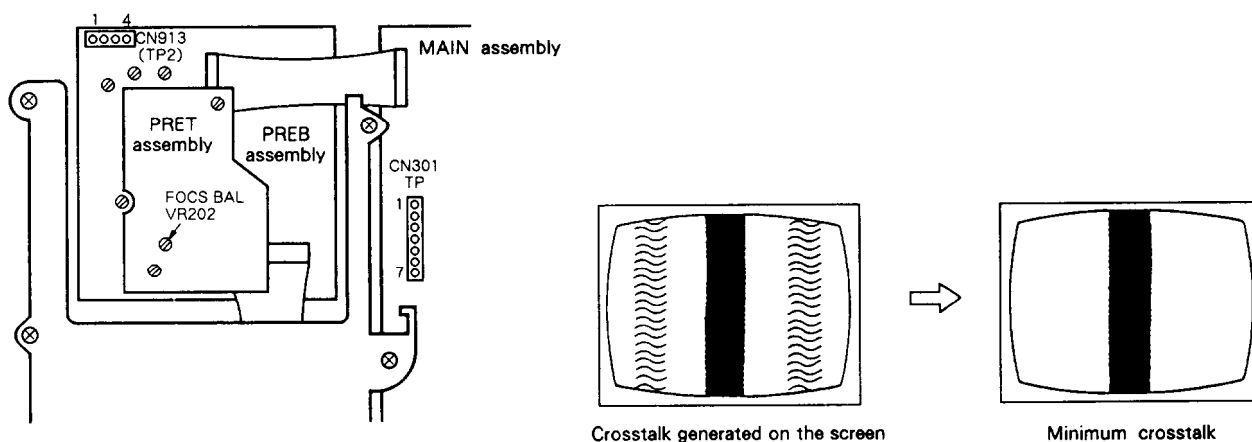
**Connection diagram**

2. Adjust VR202 in the PRET assembly for minimum crosstalk.

2. Adjust so that the crosstalk on the screen is minimum.

**Adjustment Procedure**

1. Play the 8-inch LD test disc and search frame #115.
2. Adjust VR202 in the PRET assembly so that the crosstalk on the left and right sides on the TV screen is minimized.  
If adjustment of VR202 fails to reduce crosstalk to an allowable level, perform "(1) Pickup Tangential Direction Angle Adjustment and Tilt Servo Balance Adjustment".

## 3. Spindle Motor Centering Check

## Mechanical Adjustment

- Purpose : To check that the center of the spindle motor is on the orbit of the laser beam.

- Measuring instruments and jigs :

- Measuring point :
- Test disc and player mode

- Positions to be adjusted

- Oscilloscope

- PREB assembly TP2-2 (TRKG error) and TP2-1 (TRKG sum)
- 8-inch LD test disc GGV1003...#100 and #22,000

- Play mode ● CD test disc (YEDS-18) ● Test Mode (TRKG servo : Open)
- The carriage assembly should be in the forward state.
- Check the Lissajous figure

## Connection diagram

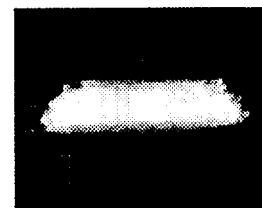
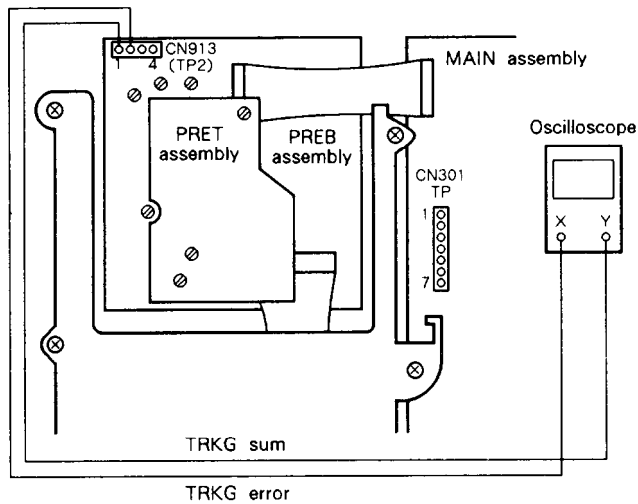

Photo 3

X : 20mV/div, AC input  
Y : 20mV/div (1:1), AC input  
X - Y mode

Lissajous figure of the inner track of the disc (CD)

Check that  $Y = Y'$

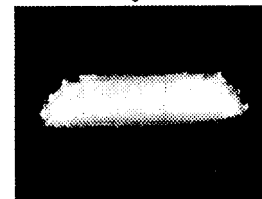

Photo 4

Lissajous figure of the outer track of the disc (CD)

5. The Y-axis of the Lissajous figure should be the same for the inner and the outer tracks.

## Checking Procedure

1. Play the 8-inch LD test disc.
2. Move the pickup to frame #22,000 by scanning or searching, then open the TRKG servo.
3. Connect TP2-2 in the PREB assembly to the X-input (CH-1) of the oscilloscope and TP2-1 to the Y-input (CH-2).

Set the oscilloscope to the X-Y mode and observe the Lissajous figures of the TRKG error signal and the TRKG sum signal.

4. Write down the Y-axis amplitudes of the Lissajous figures. (Photo 3)
5. Close the TRKG servo and search frame #100, then open the TRKG servo again to observe the Lissajous figure.

At this time, check that the Y-axis amplitude of the Lissajous figure is the same as that noted in step 4. (Photo 4)

6. Remove the 8-inch LD test disc from the player, then load the CD test disc and repeat the checking procedures steps 1 to 5. However, it is not necessary to specify the inner or outer track positions of the disc. If the Y-axis amplitude of the Lissajous figure is different for the inner and outer tracks, perform "4. Spindle Motor Centering Adjustment"

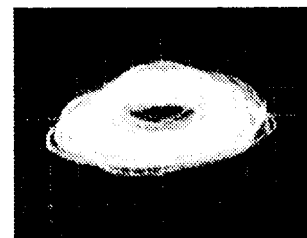

Photo 5 Lissajous figure when not properly adjusted

## 4. Spindle Motor Centering Adjustment

## Mechanical Adjustment

- Purpose : To adjust so that the center of the spindle motor is on the orbit of the laser beam.
- When not properly adjusted : Track skips, or searching takes too long.

● Measuring instruments and jigs :

● Measuring point :

● Test disc and player mode

● Positions to be adjusted

● L-shaped eccentric screwdriver ● Oscilloscope

● PREB assembly TP2-2 (TRKG error) and TP2-1 (TRKG sum)

● 8-inch LD test disc GGV1003...#100 and #22,000 ● Play mode

● Test Mode (TRKG servo : Open/Close) ● CD test disc (YEDS-7)

● The carriage assembly should be in the forward state.

● Spindle motor centering adjustment hole

## Connection diagram

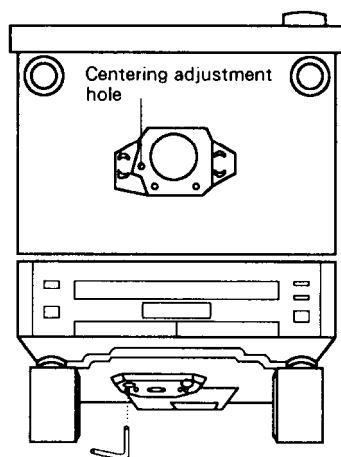

7. Adjust the centering adjustment hole.

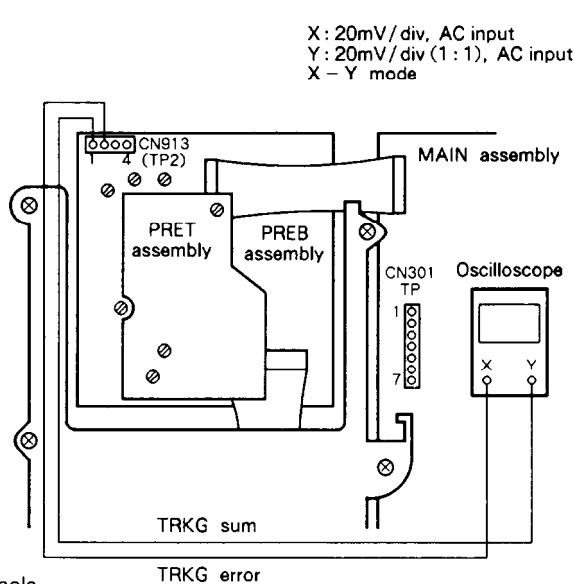

Photo 6



Photo 7

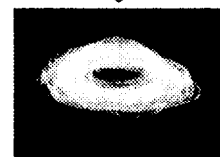

Photo 8

7. Lissajous figure.

## Adjustment Procedure

1. Connect TP2-2 in the PREB assembly to the X-input (CH-1) of the oscilloscope and TP2-1 to the Y-input (CH-2).
2. Play the 8-inch LD test disc and search frame #22,000.
3. Open the TRKG servo and observe the Lissajous figures of the TRKG error signal and the TRKG sum signal.
4. Fine-adjust the grating so that the Y-axis amplitude of the Lissajous figure is minimized. (Photo 7)
5. Close the TRKG servo and search frame #100.
6. Open the TRKG servo again and observe the Lissajous figure and write the values down. (Photo 6)
7. Insert the L-shaped eccentric screwdriver into the adjusting hole from the left bottom of the unit, and turn slowly so that the Y-axis amplitude of the Lissajous figure is reduced. After the Y-axis amplitude of the Lissajous figure is minimized, turn the adjusting screw further until the amplitude becomes the same shape as that observed in procedure 6. (Photos 6 - 8)
8. Close the TRKG servo, and move the pickup assembly to the outer track of the disc (#22,000), then perform the adjustments in steps 4 to 6 again.
9. Re-open the TRKG servo and observe the Lissajous figure to check that the Y-axis amplitude is minimum. (Photo 7) If the Y-axis amplitude of the Lissajous figure is larger than specified, repeat the adjustment procedures from steps 5 to 8.
10. After adjustment is complete, perform the adjustment in "3. Spindle Motor Centering Check" item 6.

**5. Fine Grating Adjustment**

**Mechanical Adjustment**

- Purpose : To fine adjust the grating so that the two tracking beams for the TRKG servo are projected in the optimum positions on the tracks being played. Set the TRKG servo loop offset voltage to 0V.
- When not properly adjusted : During play, tracks may be skipped.

- |  |  |
|--|--|
| <ul style="list-style-type: none"> <li>● Measuring instruments and jigs :</li> <li>● Measuring point :</li> <li>● Test disc and player mode</li> <li>● Positions to be adjusted</li> </ul> | <ul style="list-style-type: none"> <li>● Oscilloscope</li> <li>● Small ⊖ screwdriver</li> <li>● PREB assembly TP2-2 (TRKG error) and TP2-1 (TRKG sum)</li> <li>● 8-inch LD test disc GGV1003... #6,500</li> <li>● Still mode</li> <li>● Test Mode (TRKG servo : Open)</li> <li>● The carriage assembly should be in the forward state.</li> <li>● Grating</li> </ul> |
|--|--|

**Connection diagram**

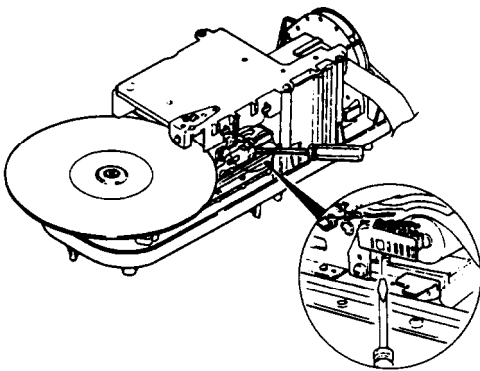

3. Insert the small ⊖ screwdriver into the grating adjustment hole to fine adjust it.

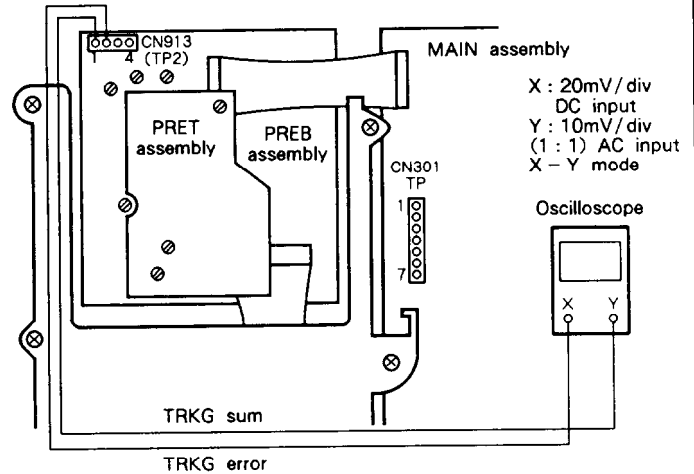

**Adjustment Procedure**

1. Play the LD test disc and search frame #6,500, then open the TRKG servo.
2. Connect TP2-2 in the PREB assembly to the X-input (CH-1) of the oscilloscope and TP2-1 to the Y-input (CH2)  
Set the oscilloscope to the X-Y mode and observe the Lissajous figures of the TRKG error signal and the TRKG sum signal.
3. Insert the small ⊖ screwdriver into the grating adjustment hole, and fine-adjust the grating so that the Y-axis amplitude of the Lissajous figures is minimized. (Photo 9)  
If the grating is turned too much and the optimum position can no longer be found, repeat the "1. Coarse Grating Adjustment".
4. Select the oscilloscope's X-input (CH-1) and check that the positive and negative amplitudes of the TRKG error signal are equal. (Photo 10)  
If they are not, repeat the "1. Tracking Balance Adjustment".

5. Close the TRKG servo and check that the picture (image) on the TV screen is normal.

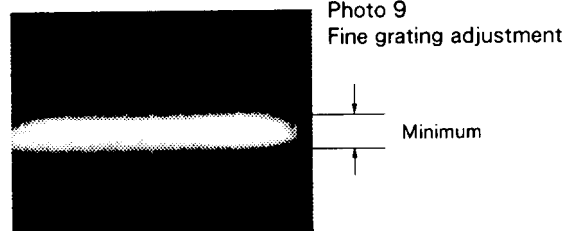

3. Y-axis amplitude of Lissajous figure becomes minimum.

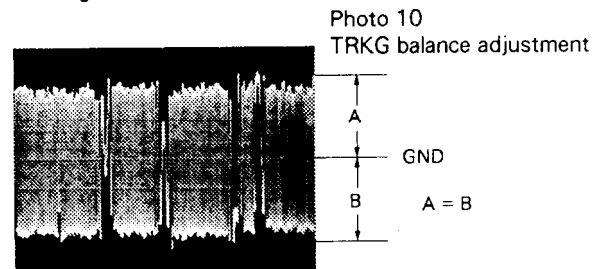

## 6. RF Gain Adjustment

## Mechanical Adjustment

- Purpose : To adjust the RF signal amplitude to the optimum value.
- When not properly adjusted : Dropout occurs frequently.

- |  |  |
|--|--|
| <ul style="list-style-type: none"> <li>● Measuring instruments and jigs :</li> <li>● Measuring point :</li> <li>● Test disc and player mode</li> <li>● Positions to be adjusted</li> </ul> | <ul style="list-style-type: none"> <li>● Oscilloscope</li> <li>● Main assembly TP1 (RF signal)</li> <li>● 8-inch LD test disc GGV1003...#15,000    ● Still mode</li> <li>● Test Mode (TRKG servo : Close)</li> <li>● The carriage assembly should be in the forward state.</li> <li>● PRET assembly VR201 (RF gain)</li> </ul> |
|--|--|

## Connection diagram

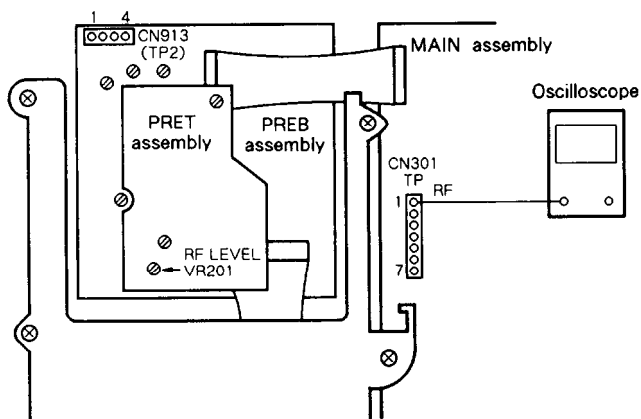

2. Connect MAIN assembly TP1 to an oscilloscope.

## Adjustment Procedure

1. Play the LD test disc and search frame #15,000.
2. Connect an oscilloscope to MAIN assembly TP1 (RF signal) and observe the RF signal.
3. Adjust PRET assembly VR201 so that the amplitude of the RF signal becomes  $300\text{ mV} \pm 50\text{ mV}$ . (Photo 11)

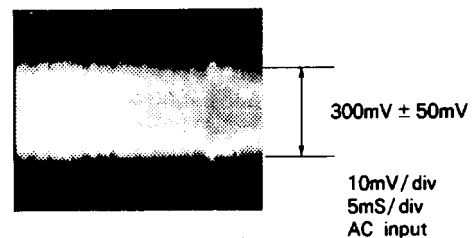

Photo 11 RF signal

## 7. FOCS Servo Loop Gain Adjustment

Mechanical Adjustment

- Purpose : To set the loop gain of the FOCS servo to the optimum value.
- When not properly adjusted : Performance deteriorates.

## ● Measuring instruments and jigs :

## ● Measuring point :

## ● Test disc and player mode

## ● Positions to be adjusted

- Oscilloscope
- AF oscillator
- Resistor (100k ohms)

## ● MAIN assembly TP3 (FOCS error) and TP5 (FOCS gain)

## ● 8-inch LD test disc GGV1003... #15,000

## ● TRKG servo : Close

## ● The FOCS motor protection circuit is disabled.

## ● The carriage assembly should be in the forward state.

## ● PRET assembly VR203

## Connection diagram

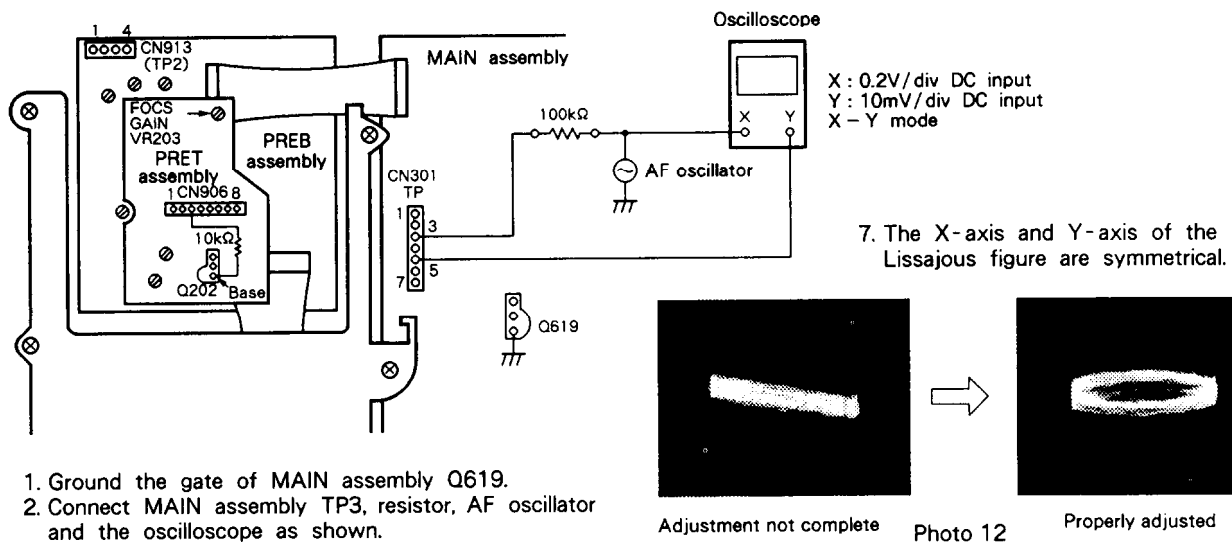

## Adjustment Procedure

1. Connect the base of Q202 in the PRET assembly to GND to inhibit the operation of the CN906 pin 3.
2. Ground the Q619 gate of the MAIN assembly to stop the function of the focus motor protection circuit.
3. Connect MAIN assembly TP3 to the oscilloscope's X-input (CH-1) via the resistor and AF oscillator, and TP5 to the Y-input (CH-2), as shown in the above diagram.
4. Set the AF oscillator output to 1.6 kHz/6 Vp-p.
5. Play the 8-inch LD test disc and search frame #15,000.
6. Set the oscilloscope to the X-Y mode and observe the Lissajous figure.
7. Adjust VR203 in the PRET assembly so that the Lissajous figure is symmetrical on both the X-axis and Y-axis of the oscilloscope. (Photo 12)

8. Release the grounding from Q619 in the MAIN assembly.

Note : If the AF oscillator output does not exceed 6Vp-p, reduce the value of the resistor (100k ohms) in the above diagram, for easier observation of the Lissajous figure. (not below 33k ohms)



## 8. TRKG Servo Loop Gain Adjustment

Mechanical Adjustment

- Purpose : To set the loop gain of the TRKG servo to the optimum value.
- When not properly adjusted : Performance deteriorates

- Measuring instruments and jigs :
- Measuring point :
- Test disc and player mode
- Positions to be adjusted

- Oscilloscope
- Resistor (100k ohms)
- AF oscillator
- MAIN assembly TP4 (TRKG error) and TP7 (TRKG gain)
- 8-inch LD test disc GGV1003...#15,000
- Still mode
- TRKG servo : Close
- The carriage assembly should be in the forward state.
- PREB assembly VR102

## Connection diagram

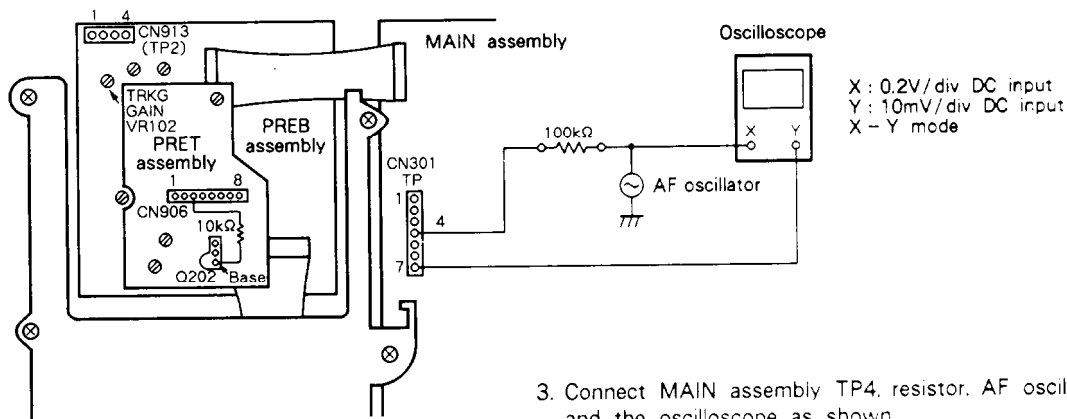

## Adjustment Procedure

1. Connect the base of the PRET assembly Q202 to GND to inhibit the operation of the CN906 pin 3.
  2. Play the LD test disc and search frame #15,000.
  3. Connect MAIN assembly TP4 to the oscilloscope's X-input (CH-1) via the resistor and AF oscillator, and TP7 to the Y-input (CH-2), as shown in the above diagram.
  4. Set the AF oscillator output to 3.4kHz/6Vp-p.
  5. Set the oscilloscope to the X-Y mode and observe the Lissajous figure.
  6. Adjust VR102 in the PREB assembly so that the Lissajous figure is symmetrical on both the X-axis and Y-axis of the oscilloscope. (Photo 13)
- Note: If the AF oscillator output does not exceed 6Vp-p, reduce the value of the resistor (100k ohms) in the above diagram, for easier observation of the Lissajous figure. (not below 33k ohms)



Adjustment not complete

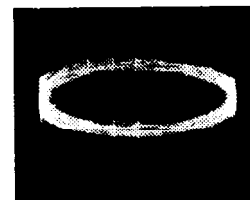

Properly adjusted

Photo 13



## 9. Centering Adjustment for Side B Play

## Mechanical Adjustment

- Purpose : To set the center of the spindle motor on the path of the laser beam when playing the side B of the disc.
- When not properly adjusted : Tracks skipped, longer searching time or searching is impossible when playing side B of the disc.

## ● Measuring instruments and jigs :

## ● Measuring point :

## ● Test disc and player mode

## ● Positions to be adjusted

## ● L-shaped eccentric screwdriver ● Oscilloscope

## ● MAIN assembly TP4 (TRKG error), PREB assembly TP2-1 (TRKG sum)

## ● 8-inch LD test disc GGV1002...#100 ● Play mode

## ● The carriage assembly should be in the reverse state.

## ● Test mode (TRKG servo : Open/Close)

## ● Centering adjustment hole for side B

## Connection diagram

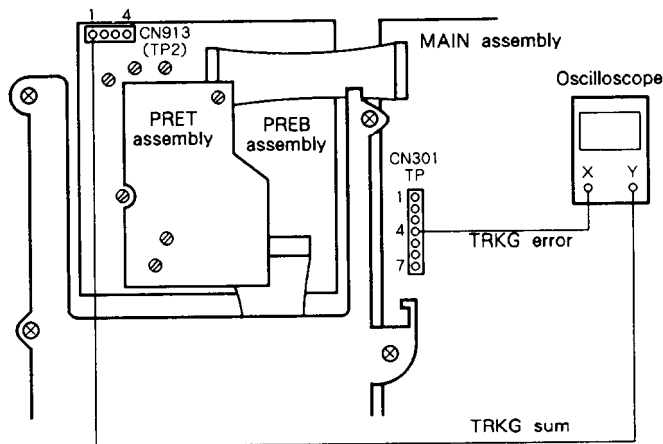

X : 20mV/div DC input  
Y : 10mV/div DC input  
X - Y mode

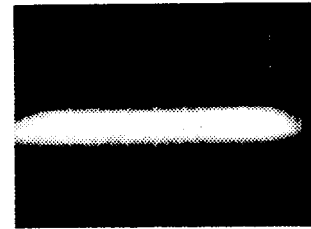

Photo 14

4. Centering adjustment for side B play.

4. Properly adjusted (X : maximum).

## Adjustment Procedure

1. Turn the LD test disc upside-down (change from side A to side B).
2. Set the oscilloscope to the X-Y mode, and connect MAIN assembly TP4 (TRKG error) to the oscilloscope's X-input (CH-1) and PREB assembly TP2-1 (TRKG sum) to the Y-input (CH-2).
3. Play the LD test disc and search frame #100, then open the tracking servo.

Note: If the center is too eccentric on side B of the disc, since searching will be impossible on side B, open the TRKG servo when the carriage assembly moves to the side B play position and searches around frame #100.

4. While observing the Lissajous figure on the oscilloscope, insert the eccentric screwdriver into the centering adjustment hole for side B and adjust it so that the X-axis amplitude of the Lissajous figure is minimized (on-track position). Then turn the eccentric screwdriver clockwise further until the X-axis amplitude of the Lissajous figure becomes maximum. (Photo 14)

Note: When "2 (1) Tangential Direction Angle Adjustment" is performed with the pickup in the forward state, perform "10. Pickup Tangential Direction Angle Adjustment for Side B Play" and "11. Fine Centering Adjustment for Side B play".

**10. Pickup Tangential Direction Angle Adjustment for Side B Play****Mechanical Adjustment**

- Purpose : To adjust the crosstalk to become minimum in the tangential direction angle of the pickup assembly when playing side B of the disc.
- When not properly adjusted : Crosstalk is significant.

- Measuring instruments and jigs :
- Measuring point :
- Test disc and player mode
- Positions to be adjusted

- TV monitor
- Small Philips head screwdriver
- Monitor screen
- 8-inch LD test disc GGV1002...#115
- Still mode
- The carriage assembly should be in the reverse state.
- Pickup tangential direction angle adjustment screw

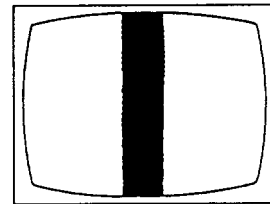
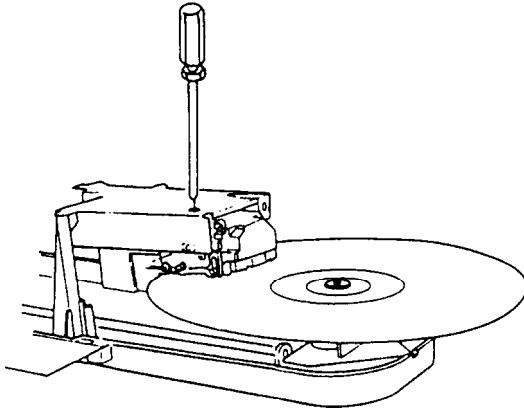
**Connection diagram**

2. Minimum crosstalk

**Adjustment Procedure**

1. Play the LD test disc and search frame #115.
2. Check if crosstalk appears on the screen of the TV monitor, and adjust the pickup tangential direction angle adjustment screw so that the crosstalk is minimized.
3. After steps 1 and 2 have been completed, perform "9. Centering Adjustment for Side B Play" again.

Note : When the pickup tangential direction angle for side B play is varied by this adjustment, the center of the disc for side B may be shifted slightly. As a countermeasure, perform the centering adjustment again.

## 11. Fine Centering Adjustment for Side B Play

Mechanical Adjustment

- Purpose : To set the center of the spindle motor on the track of the laser beam when playing the side B of the disc.
- When not properly adjusted : Tracks skipped when playing side B of the disc.

● Measuring instruments and jigs :

● Measuring point :

● Test disc and player mode

● Positions to be adjusted

● Oscilloscope ● L-Shaped eccentric screwdriver

● MAIN assembly TP4 (TRKG error), PREB assembly TP2-1 (TRKG sum)

● 8-inch LD test disc GGV1002... #100 ● Test mode (TRKG servo:Open)

● Play mode ● The carriage assembly should be in the reverse state.

● Centering adjustment hole for side B

## Connection diagram

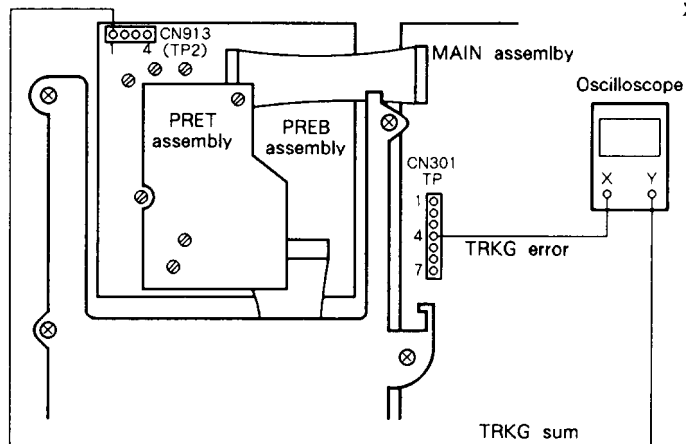

X : 20mV/div DC input  
Y : 10mV/div DC input  
X - Y mode

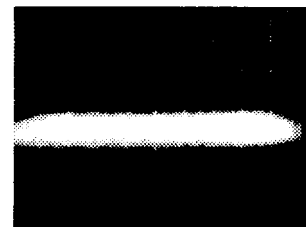

Photo 15

4. Fine centering adjustment for side B play.

4. X-axis of Lissajous figure maximum.

## Adjustment Procedure

1. Set the oscilloscope to the X-Y mode, and connect MAIN assembly TP4 (TRKG error) to the oscilloscope's X-input (CH-1) and PREB assembly TP2-1 (TRKG sum) to the Y-input (CH-2).
2. Play the LD test disc and search frame #100.
3. Open the TRKG servo.
4. While observing the Lissajous figure on the oscilloscope, insert the eccentric screwdriver into the centering adjustment hole for side B and adjust it so that the X-axis amplitude of the Lissajous figure becomes maximum. (Photo 15)

## 9.4 ELECTRICAL ADJUSTMENTS

### 1. 14.31818 MHz

[Electrical Adjustment]

- Purpose : Adjustment of the standard clock frequency.
- Symptom when incorrectly adjusted : Incorrect color tint, no TV color lock, and VCXO cannot be adjusted during LDD playback.

Measurement equipment & jigs	Measurement equipment connecting points	Player condition	Adjusting points
<ul style="list-style-type: none"> <li>● Frequency counter</li> <li>● Oscilloscope 10 : 1 probe</li> </ul>	<ul style="list-style-type: none"> <li>● JP (14.31818)</li> </ul>	<ul style="list-style-type: none"> <li>● Normal mode</li> <li>● STOP mode (Blueback screen)</li> </ul>	<ul style="list-style-type: none"> <li>● VC901 on the MAIN assembly</li> </ul>

#### Adjusting procedure

1. Adjust VC901 on the MAIN assembly so that the frequency becomes 14.31818 MHz in the STOP mode (blueback screen).

*Note : The frequency counter probe should be an oscilloscope 10 : 1 probe.*

#### Adjustment diagram

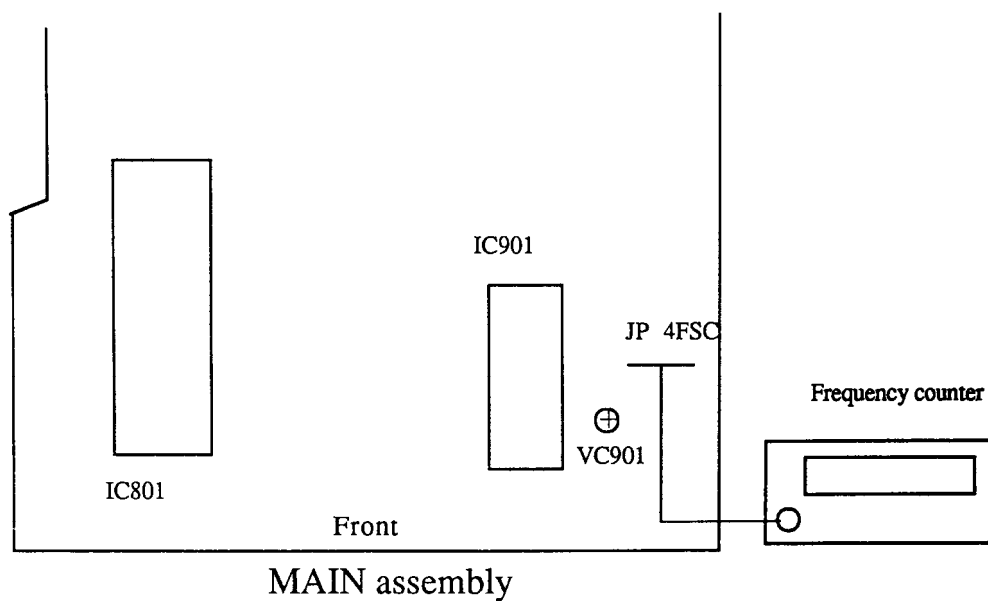

## 2. VCO CENTERING FREQUENCY ADJUSTMENT

[Electrical Adjustment]

- Purpose : Setting the optimum delay time for the time axis error compensation CCD.
- Symptom when incorrectly adjusted : It is difficult to color lock, there is color lock delay after a search, and there is flicker on the white screen.

Measurement equipment & jigs	Measurement equipment connecting points	Player condition	Adjusting points
<ul style="list-style-type: none"> <li>● Oscilloscope</li> <li>● Test disc (GGV1003)</li> </ul>	<ul style="list-style-type: none"> <li>● Oscilloscope</li> <li>CH 1 : C489 lead wire.</li> <li>CH 2 : C519 lead wire. (CCD OUT)</li> </ul>	<ul style="list-style-type: none"> <li>● Normal mode</li> <li>● STILL mode</li> </ul>	<ul style="list-style-type: none"> <li>● VR481</li> </ul>

### Adjusting procedure

1. Connect the C489 lead wire and the C519 lead wire to CH 1 and CH 2 of the oscilloscope respectively.

CH 1 : Video signal *before* time axis error compensation.  
CH 2 : Video signal *after* time axis error compensation.

2. Search for frame #5100 on the test disc. Adjust VR481 so that the center of CH 1's video signal jitter is delayed by  $71\mu\text{s}$  ( $1\text{H} + 7.5\mu\text{s}$ ) with respect to the CH 2's video signal.

*Note : Do not confuse CH 1 and CH 2.*

### Adjustment diagram

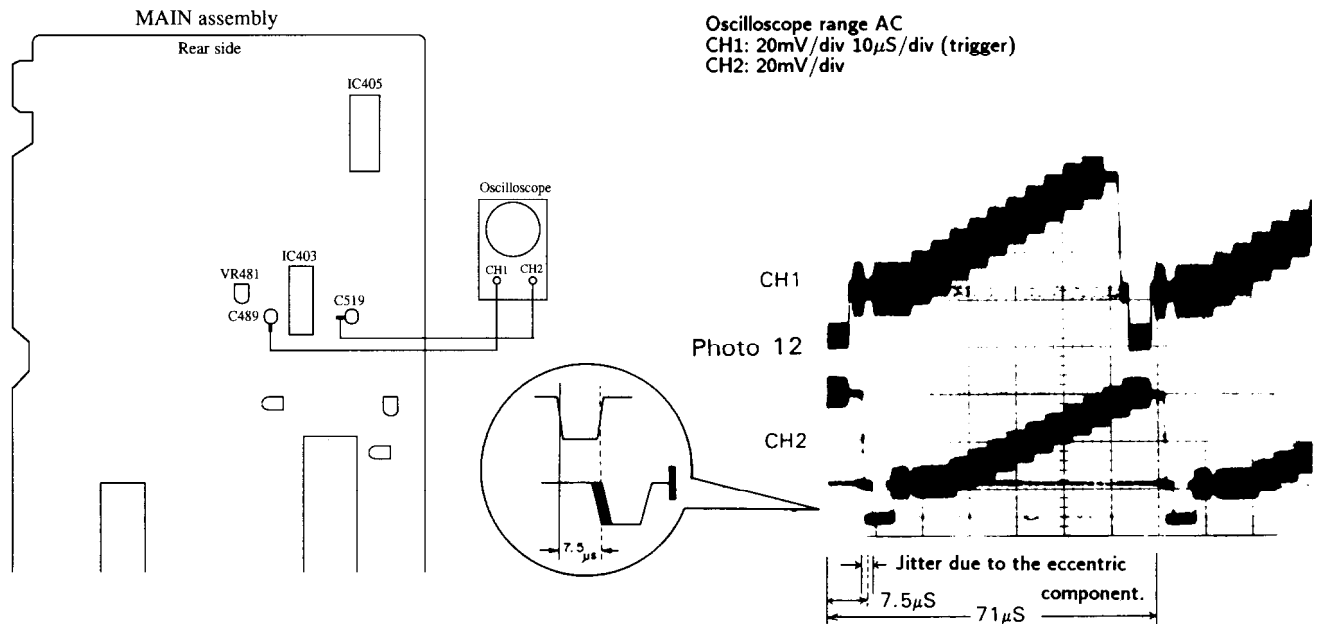

### 3. OUTPUT VIDEO LEVEL ADJUSTMENT

[Electrical Adjustment]

- Purpose : Setting the video signal level to 1Vp-p(75Ω termination).
- Symptom when incorrectly adjusted : The player starts up midway without reading the data. The screen is too bright or too dark.

Measurement equipment & jigs	Measurement equipment connecting points	Player condition	Adjusting points
<ul style="list-style-type: none"> <li>● Oscilloscope</li> <li>● Test disc (GGV1003)</li> </ul>	<ul style="list-style-type: none"> <li>● Oscilloscope</li> <li>● Player video output terminal</li> </ul>	<ul style="list-style-type: none"> <li>● Normal mode</li> <li>● STILL mode</li> <li>● #19900</li> </ul>	<ul style="list-style-type: none"> <li>● VR482</li> </ul>

#### Adjusting procedure

*Note : Since the video output terminal will be connected to a TV monitor, it is to have 75Ω termination. (If it is connected to a TV via VHF OUT, terminate the video output terminal with a resistance of 75Ω.)*

1. Search for frame #19900 on the test disc.
2. Adjust VR482 so that the white level becomes  $1V \pm 5\%$  from the video signal's sync tip level.

#### Adjustment diagram

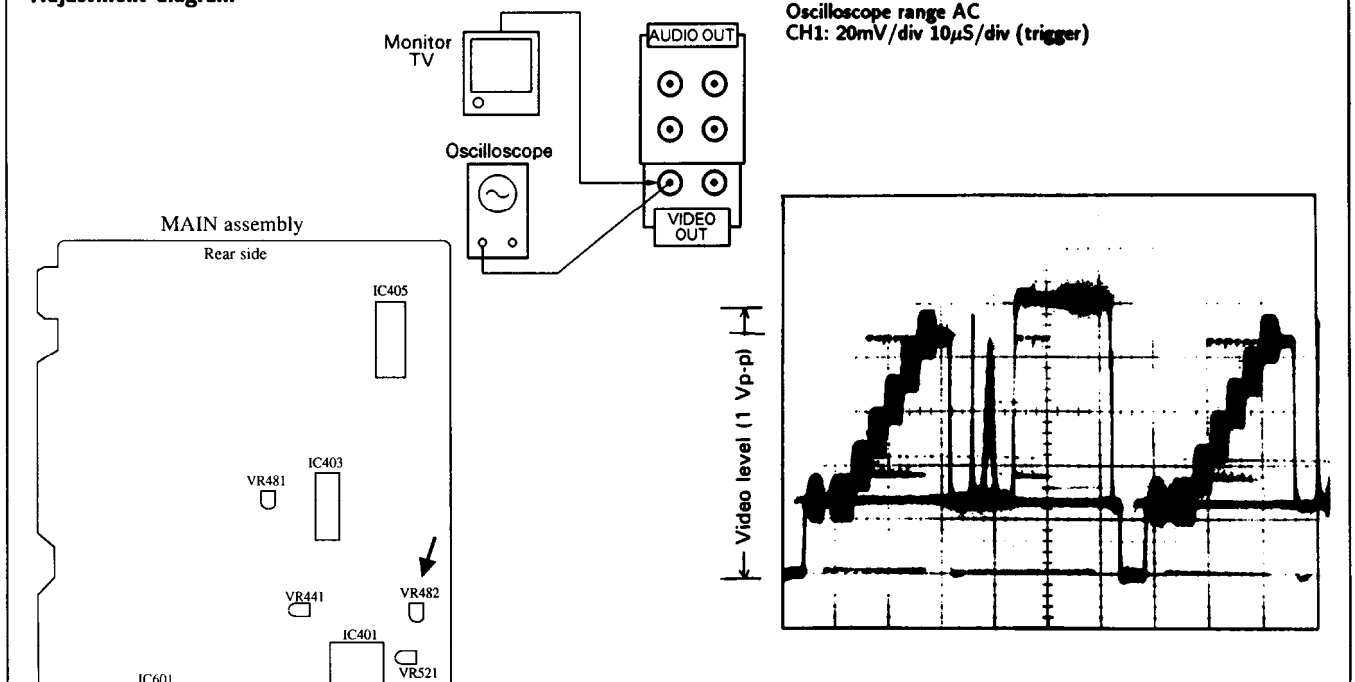

### 4. 1H Delay Video Level Adjustment

[Electrical Adjustment]

- Purpose : Equalization of the video levels of the 1 H delay video signal and the main line video signal.
- Symptom when incorrectly adjusted : If the 1 H delay video signal level is high, white dropout will be noticeable and there will be H shifting. (Horizontal stripes across the screen.)  
If the 1 H delay video signal level is low, black dropout will be noticeable.

Measurement equipment & jgs	Measurement equipment connecting points	Player condition	Adjusting points
<ul style="list-style-type: none"> <li>● Oscilloscope</li> <li>● Test disc (GGV1003)</li> </ul>	<ul style="list-style-type: none"> <li>● Oscilloscope</li> <li>CH 1 : Between IC401's pin 42 and GND.</li> <li>CH 2 : Pin 40 of IC401.</li> </ul>	<ul style="list-style-type: none"> <li>● Normal mode</li> <li>· STILL mode</li> </ul>	<ul style="list-style-type: none"> <li>● VR441</li> </ul>

#### Adjusting procedure

1. Search for frame #3800 on the test disc.
2. Adjust VR441 so that the 1 H delay video level (CH 2) becomes the same as the main line video level (CH 1). (See Photo 14.)

*Note : The video level is the level between the SYNC tip and the white peak.*

#### Adjustment diagram

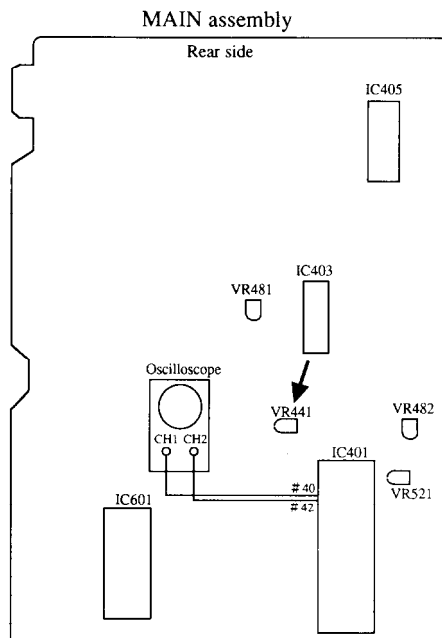

Oscilloscope range. AC  
CH1: 20mV/div 10μS/div  
CH2: 20mV/div

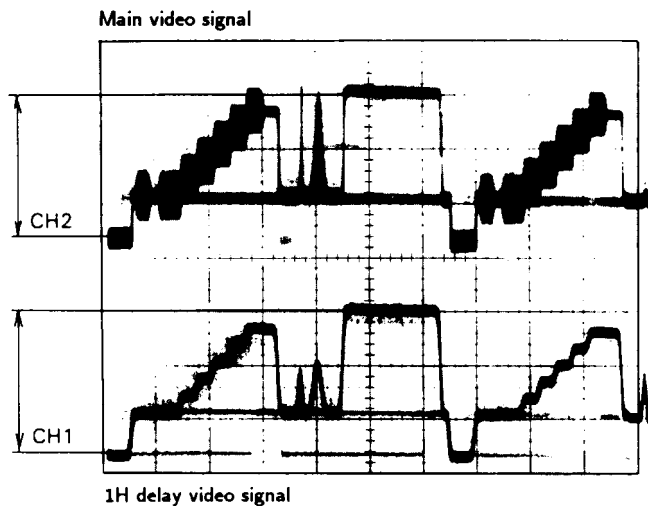

Photo 14

## 5. Color Tint Error Signal Level Adjustment

[Electrical Adjustment]

- Purpose : Optimization of the color tint compensation section's error signal level.
- Symptom when incorrectly adjusted : There is substantial color irregularity. (Especially for CDV.)

Measurement equipment & jigs	Measurement equipment connecting points	Player condition	Adjusting points
<ul style="list-style-type: none"> <li>● TV monitor</li> <li>● Test disc (GGV1003)</li> </ul>	<ul style="list-style-type: none"> <li>● TV monitor</li> </ul>	<ul style="list-style-type: none"> <li>● Normal mode</li> <li>● STILL mode</li> </ul>	<ul style="list-style-type: none"> <li>● VR521</li> </ul>

## Adjusting procedure

1. Search for frame #8000 on the test disc. (Magenta screen)
2. Adjust VR521 until the color irregularity on the magenta screen is minimized.

## Adjustment diagram

