

ONKYO SERVICE MANUAL

STEREO GRAPHIC EQUALIZER

MODEL EQ-08

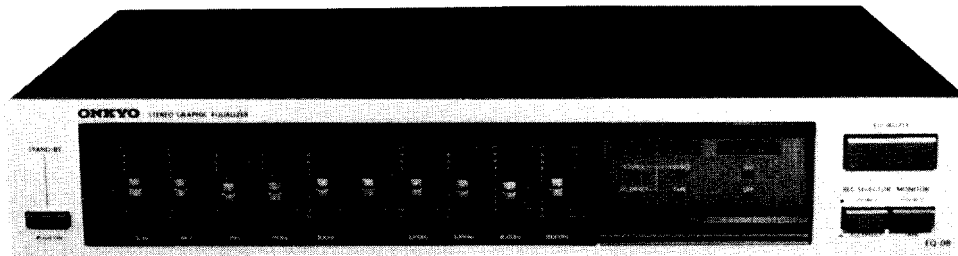

TABLE OF CONTENTS

Item	Page
Specifications	2
Block diagram	2
Precaution	3
Exploded view	4
Component location	5
Using the level controls	6
Printed circuit board view from component side	7
Schematic diagram	9
Printed circuit board-parts list	11
Packing procedures	12

ONKYO
AUDIO COMPONENTS

ONKYO SERVICE MANUAL

STEREO GRAPHIC EQUALIZER MODEL EQ-08(B)

Black model

NOTE.

For model EQ-08 (B), read EQ-08 as EQ-08 (B), But the following parts are not the same on models EQ-08 (B) and EQ-08.

PAGE	REF. NO.	PARTS NO.	DESCRIPTION
4	A12	19338121	Front panel ass'y
4	A17	28184232	Top cover
4	A20	28320895	Knob, Push switch
4	A21	28320929	Knob, Power switch
4	A22	28321529	Knob, Equalizer switch
4	A23	28321530	Knob ass'y, Variable resistor
12	A851	29050942	Master carton box
12		29365006-5	Warranty card (U)
12		29358002A	Service station list (U)

(U): Only U.S.A. model



SPECIFICATIONS

Input:	Input sensitivity (FLAT): 150 mV Input impedance: 50 kohms
Output:	Output voltage (FLAT): 150 mV Output impedance: 3.0 kohms
Max. input:	5 volts, 20 Hz – 20 kHz, 0.05% THD
Frequency response:	+0, –0.5 dB at 10 Hz – 50 kHz
Total harmonic distortion:	Less than 0.01% at 20 Hz – 20 kHz, 1.5 V output (FLAT)
Signal-to-noise ratio:	100 dB, 1.5V output, IHF-A input short
Adjustable range:	±12 dB
Gain:	0 dB
Semiconductors:	11 ICs, 18 diodes
AC outlet:	200 watts (UNSWITCHED) (USA, Canada Model only)
Power supply:	AC 120 V, 60 Hz (USA, Canada) AC 240 V, 50 Hz (Australia, U.K.) AC 120 V/220V, 50/60 Hz (Europe, others)
Dimensions (W x H x D):	418 x 80 x 260 mm
Weight:	3.1 kg, 6.8 lbs.

BLOCK DIAGRAM

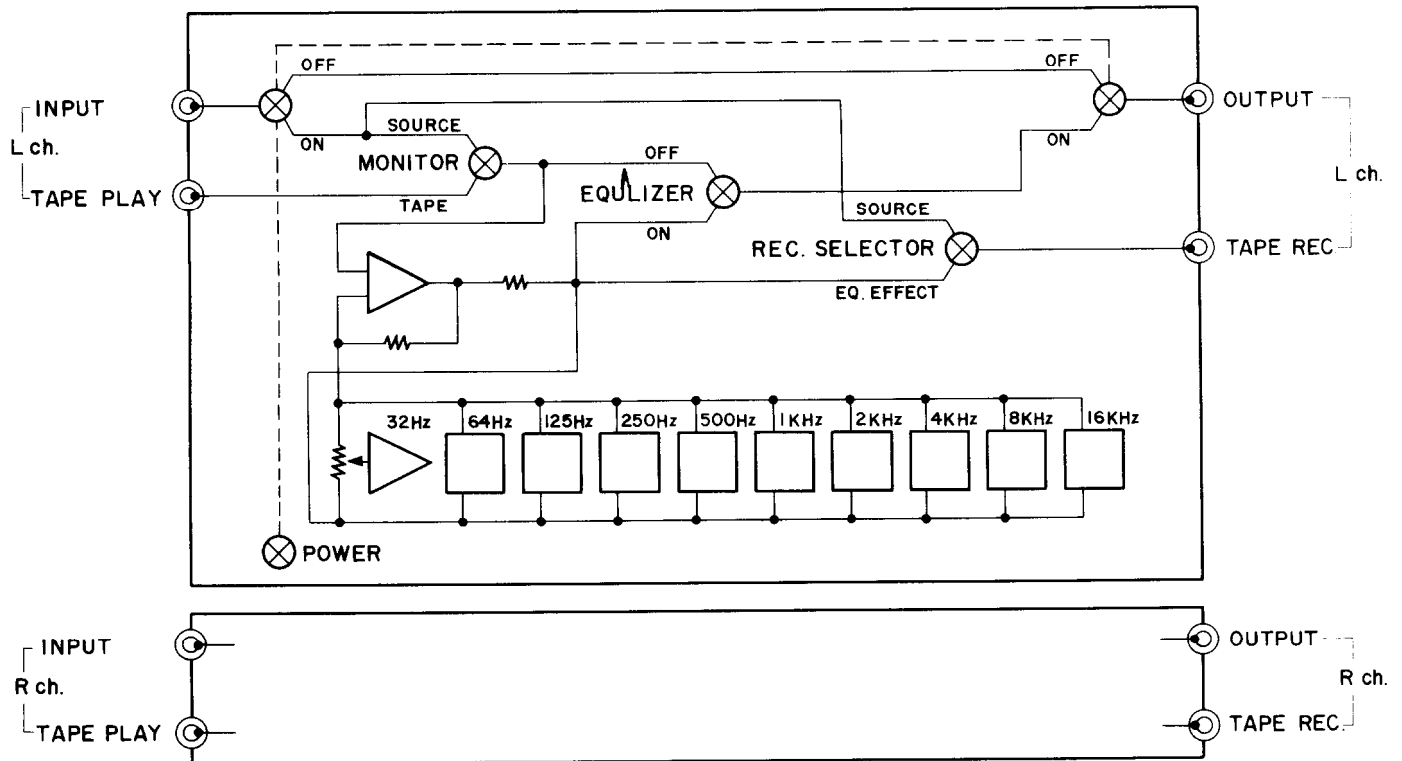

IC BLOCK DIAGRAM

NJM4558, NJM4560

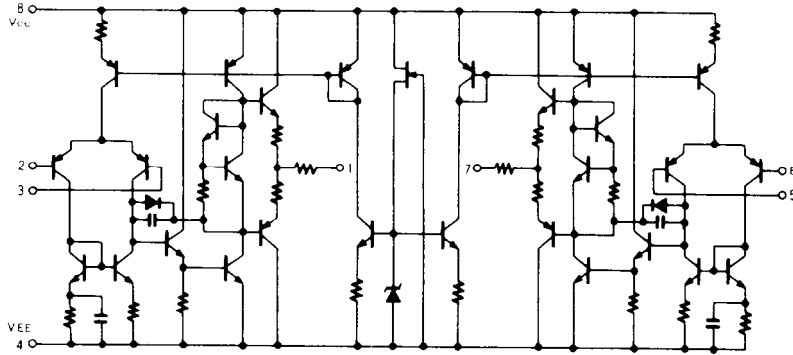

PRECAUTION

1. Voltage Selector (rear panel)

Some models are equipped with a voltage selector to conform with local power supplies. Be sure to set this switch to match the voltage of the power supply in your area before turning the power switch on. Voltage is changed by sliding the groove in the switch with a screwdriver or similar instrument to the right or left position. Confirm that the switch has been moved all the way to the right or left before turning the power switch on. If there is no voltage selector switch on the unit you have purchased, it can only be used in areas where the power supply voltage is the same as that of the unit.

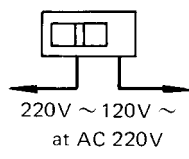
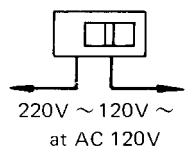

EXPLODED VIEW

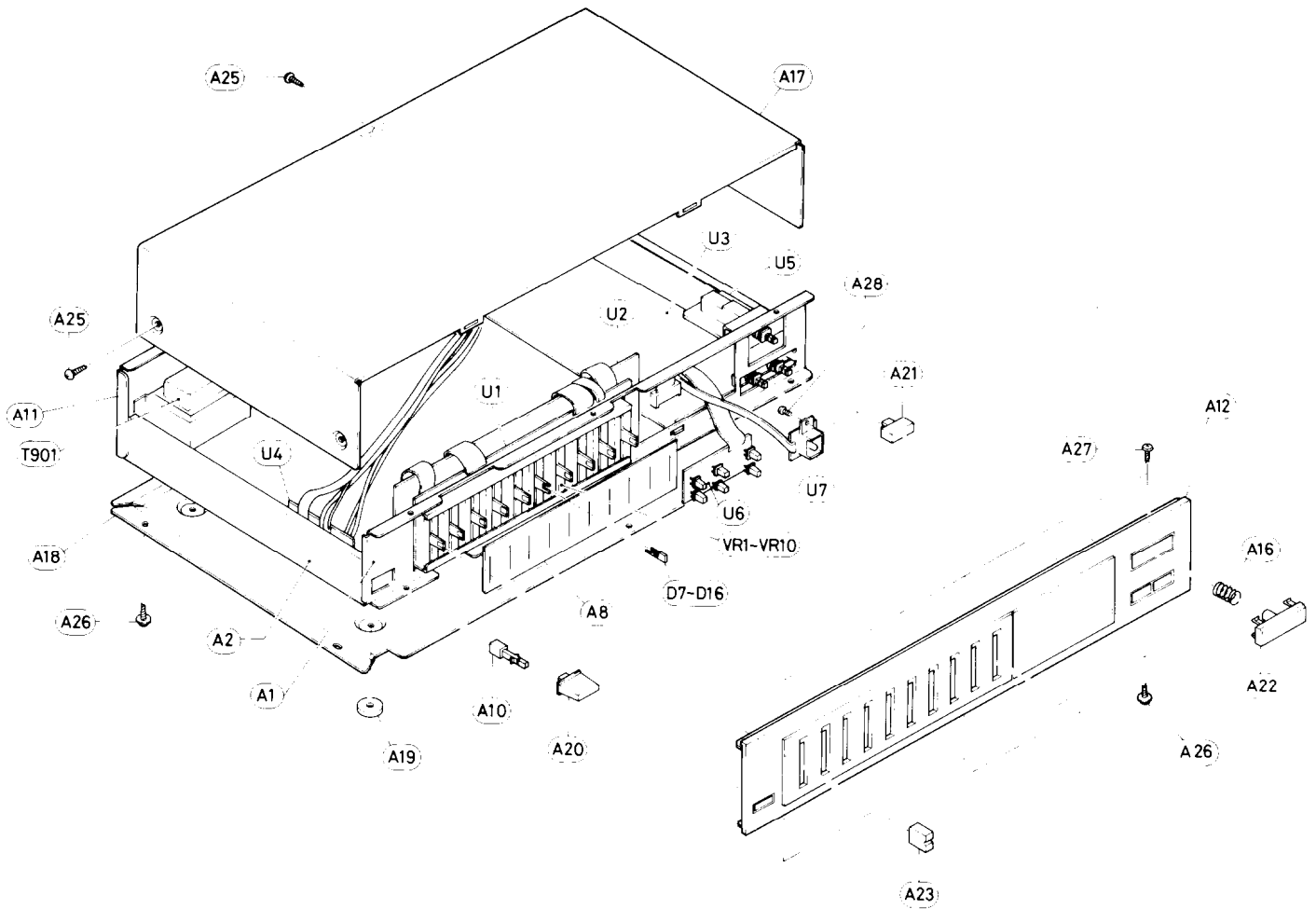

REF.NO.	PARTS NO.	DESCRIPTION	REF.NO.	PARTS NO.	DESCRIPTION
A1	27110174	Front bracket	A25	834430068	3TTS+6B(BC), Tapping screw
A2	27115123	Side bracket	A26	831130088	3TTW+8B, Tapping screw
A8	28140416	Cushion	A27	838230088	3TTB+8B(Ni), Tapping screw
A10	27260062	Shaft	A28	833120052	3STS+5BQ, Tapping screw
A11	27120415	Back panel (D)		28190009	Strainrelief (Q)
A11	27120416	Back panel (W)		28190008	Strainrelief (D) (W)
A11	27120417	Back panel (Q)	T901	230630	NPT-785D, Power transformer (D)
A12	19828121	Front panel ass'y	T901	230629	NPT-785DG, Power transformer (W)
A16	27180137	Spring	T901	230631	NPT-785Q, Power transformer (Q)
A17	28184148	Top cover	C101	335251039	0.01 μ F, 500V, Capacitor
A18	27170093B	Bottom board	J1	253099A	AS-UC-3, Power supply cable (D)
A19	27175011C	Leg		253083	AS-CEE, Power supply cable (W)
A20	28320573	Knob, push switch	J1	253077	3SH1NUQA, Power supply cable (Q)
A21	28320760	Knob, power switch			
A22	28320806	Knob, equalizer switch			
A23	28320807	Knob ass'y, variable resistor			

COMPONENT LOCATION

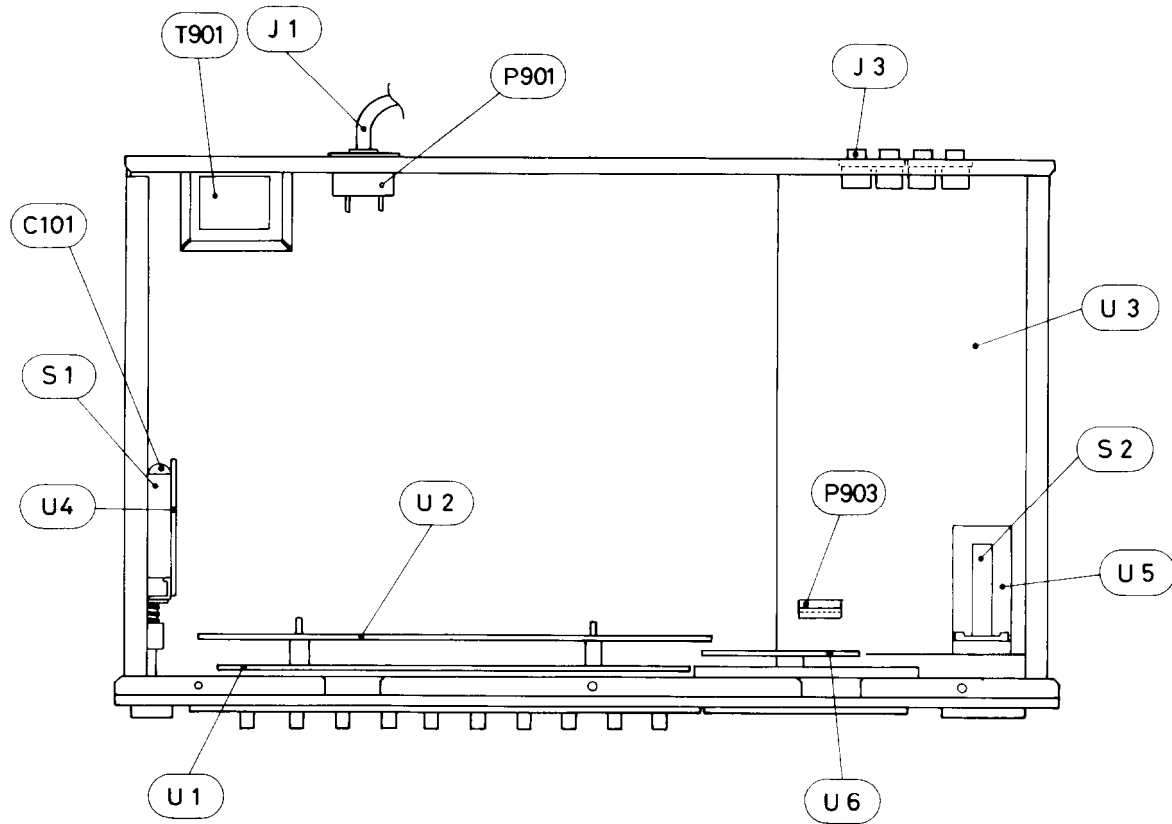

REF.NO.	PARTS NO.	DESCRIPTION	REF.NO.	PARTS NO.	DESCRIPTION
J2	25060055	NTM-2PMN22, Terminal (W)	U4	19828552	NASW-1452, Power switch pc board ass'y
S1	25035317	NPS-162-L281, Power switch	U5	19828553	NASW-1453, Equalizer switch pc board ass'y
S2	25035334	NPS-162-L298, Equalizer switch	U6	19828554	NALED-1454, Selector display LED pc board ass'y
S5	25065195	NSS-1288P, Slide switch (W)	U7	19828555	NAPL-1455, Lamp pc board ass'y
P901	25050124	NSCT-2P27T, AC outlet (D)			
P903	25050135	NSCT-7P37, Socket			
D7-D16	225118	BG4503K-5, LED			
VR1-VR10	6142010	N30LGPC100KWTP15F, Variable resistor			
U1	19828549	NAVR-1449, Level control pc board ass'y			
U2	19828550	NAAF-1450, Main pc board ass'y			
U3	19828551	NAPS-1451, Power supply and input/output terminal pc board ass'y			

NOTE

- (D) Only 120V model
- (W) Only 120V/220V model
- (Q) Only Australia model

USING THE LEVEL CONTROLS

Equalization range

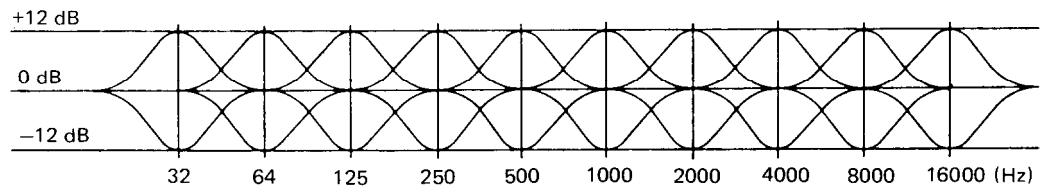

32 Hz

This frequency range is not found in records and pre-recorded tapes. It is felt more as a vibration or wave of pressure than as music. Lowering this level control is often an effective way to cut out motor noise, rumble and other unwanted low-frequency elements from a turntable.

64 Hz

This range includes the low rumbling sort of sounds created by a pipe organ or the lowest range of a piano. Lowering this level control eliminates humming noises from electric musical instruments, ventilation systems and other sources.

125 Hz

Frequencies around 125 Hz are the standard “bass” tones most people are familiar with. The position of this level control is very important since it has a major effect on the amount of “richness” or “body” in the music.

250 Hz – 500 Hz

These two frequency ranges contain most sounds from musical instruments and voices. Consequently, the positions of these two level controls determine the amount of power and warmth in the music.

1000 Hz

Sounds in this range seem to strike the face, giving music a lively feeling that should be emphasized or attenuated according to the music program and listening environment.

2000 Hz

This frequency range contains the sounds that seem to pierce the ears to give trumpet notes their strength. Use this level control to adjust the power of music of this sort.

4000 Hz

Sounds in this range give music its sparkle. It is particularly important in controlling the clarity of high violin notes and other soft, high range tones.

8000 Hz

Adjusting this level control affects the barely audible high range tones that give music a feeling of detail. This is also the range where most tape noise is located so lowering this control is useful in suppressing annoying background hissing when playing back cassettes.

16000 Hz

Frequencies this high are mainly harmonics and overtones of other notes of musical instruments. Adjusting this level control affects the delicacy of the music and the sensation of the music “flowing” or “drifting.”

SCHEMATIC DIAGRAM

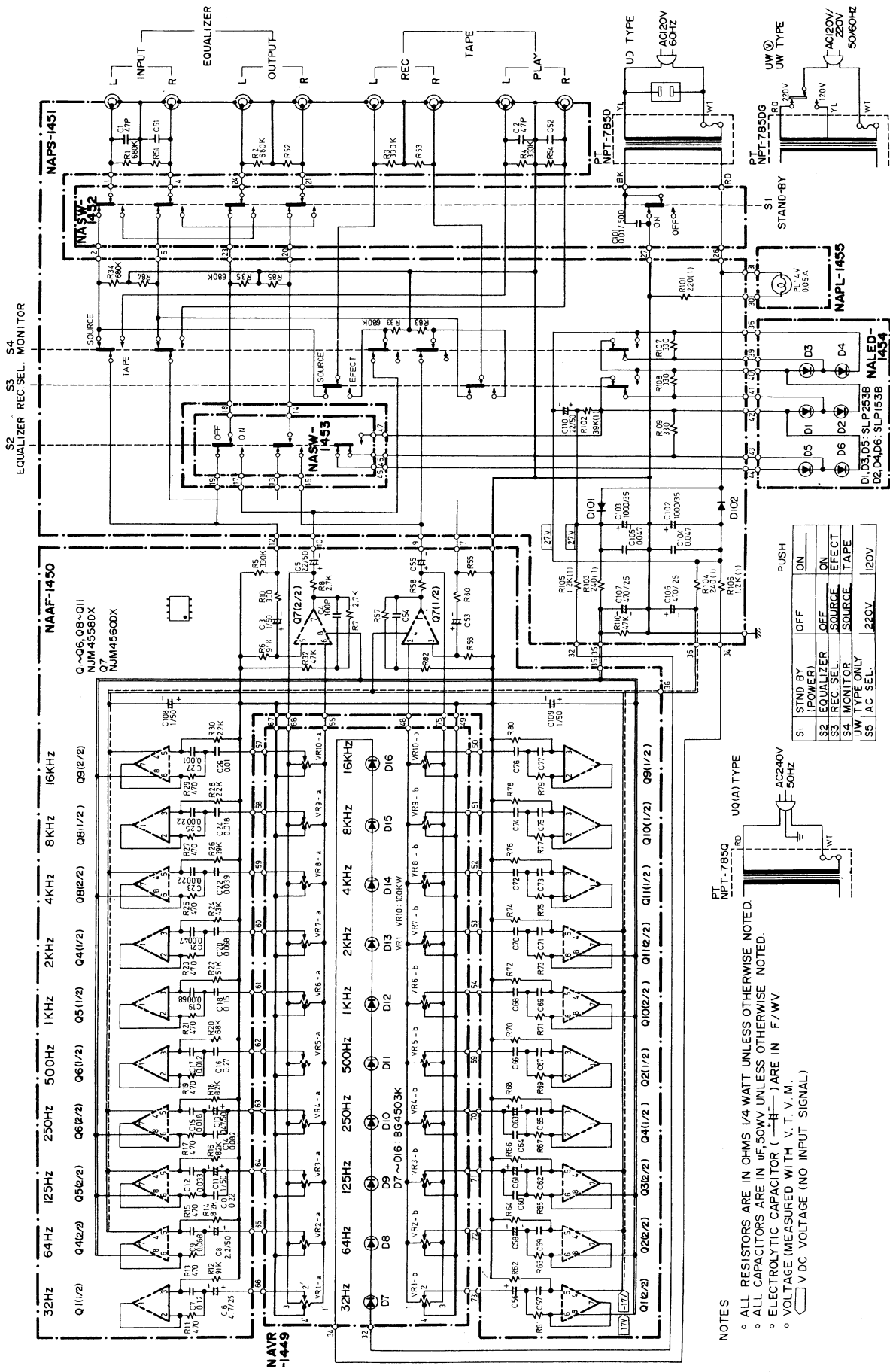

NOTES

- ALL RESISTORS ARE IN OHMS 1/4 WATT UNLESS OTHERWISE NOTED.
- ALL CAPACITORS ARE IN μ F, 50WV UNLESS OTHERWISE NOTED.
- ELECTROLYTIC CAPACITOR (—E—) ARE IN F/WV
- VOLTAGE MEASURED WITH V. T. V. M.
- V DC VOLTAGE (NO INPUT SIGNAL)

S1	STAND BY	OFF	ON
S2	EQUALIZER	OFF	ON
S3	REC. SEL.	OFF	ON
S4	MONITOR	SOURCE	EFFECT
S5	AC SEL.	220V	120V

PRINTED CIRCUIT BOARD-PARTS LIST

FREQUENCY LEVEL CONTROL PC BOARD (NAVR-1449)

CIRCUIT NO.	PARTS NO.	DESCRIPTION
D7-D16	225118	BG-4503K-5, LED
VR1-VR10	6142010	N30LGPC100KWTP15F, Slide variable resistors

MAIN PC BOARD (NAAF-1450)

CIRCUIT NO.	PARTS NO.	DESCRIPTION
ICs		
Q1-Q16	222502	NJM4558DX
Q8-Q11	222570	NJM4560DX
Q7		
Capacitors		
C3, C11	352780109	1 μ F, 50V, Elect.
C53, C61		
C5, C8	352780229	2.2 μ F, 50V, Elect.
C55, C58		
C6, C56	352750479	4.7 μ F, 25V, Elect.
C13, C63	352784799	0.47 μ F, 50V, Elect.

POWER SUPPLY AND INPUT/OUTPUT TERMINAL PC BOARD (NAPS-1451)

CIRCUIT NO.	PARTS NO.	DESCRIPTION
Diodes		
D101, D102	223839 or 223804	IN4002 or SR1K-2
Capacitors		
C102, C103	352761029	1000 μ F, 35V, Elect.
C106, C107	352754719	470 μ F, 25V, Elect.
C110	352742209	22 μ F, 16V, Elect.
Resistors		
R101	441621814KF	180 Ω , 1W, Metal oxide film
R102	441623924KF	3.9K Ω , 1W, Metal oxide film
R103, R104	441622414KF	240 Ω , 1W, Metal oxide film
R105, R106	441621224KF	1.2K Ω , 1W, Metal oxide film
Switches		
S3, S4,	25035335	NPS-142-162-L299

SELECTOR INDICATOR PC BOARD (NALED-1454)

CIRCUIT NO.	PARTS NO.	DESCRIPTION
	225085	SLP-25 3B, LED
	225084	SLP-15 3B, LED

POWER SWITCH PC BOARD (NASW-1452)

CIRCUIT NO.	PARTS NO.	DESCRIPTION
S1	25035317	NPS-162-L28k, Power switch

EQUALIZER SWITCH PC BOARD (NASW-1453)

CIRCUIT NO.	PARTS NO.	DESCRIPTION
S2	25035334	NPS-162-L298' Equalizer switch

POWER LAMP PC BOARD (NAPL-1455)

CIRCUIT NO.	PARTS NO.	DESCRIPTION
	210145	PL14V, 0.05A, Lamp

PACKING PROCEDURES

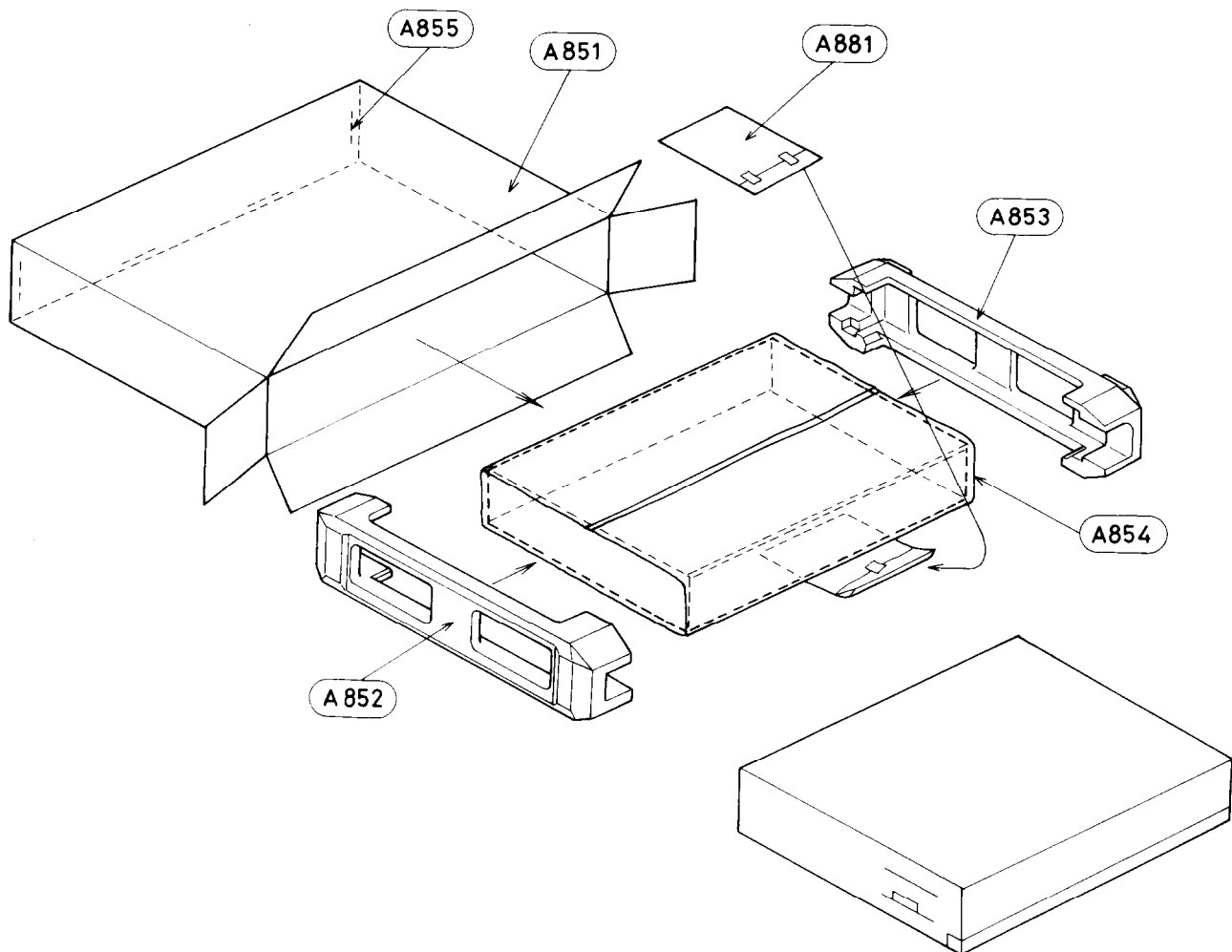

SYMBOL NO.	PARTS NO.	DESCRIPTION	SYMBOL NO.	PARTS NO.	DESCRIPTION
A851	29050564	Master carton box	A881	29340618	Instruction manual
A852	29090540B	Pad, left		2010034	Connection cord
A853	29090704	Pad, right		29365006-4	Warranty card (U)
A854	29100051	420x750mm, Poly bag		29365005-3	Warranty card (V)
	29360567	Label (U)		29358002	Service station list (U)
	29360566	Label C (U)		25055040	Conversion plug (W)
A881		Accessory bag ass'y			

NOTE

- (U) Only U.S.A. model
- (V) Only West Germany model
- (W) Only 120V/220V model

ONKYO CORPORATION

International Division: No. 24 Mori Bldg., 23-5, 3-chome, Nishi-Shinbashi, Minato-ku, Tokyo, Japan
 Telex: 2423551 ONKYO J. Phone: 03-432-6981

ONKYO U.S.A. CORPORATION

Eastern Office: 200 Williams Drive, Ramsey, N.J. 07446 Tel. 201-825-7950
 Midwest Office: 2406 Martin Lane Rolling Meadows, Ill 60008 Tel. 312-577-4300
 Western Office: 8607 Canoga Ave., Canoga Park, CA, 91304 Tel. 213-341-8114

ONKYO DEUTSCHLAND GMBH, ELECTRONICS

8034 München-Germering, Industriestrasse 18, West Germany. Telex: 521726 Telefon: (089)-84-3071