

# ONKYO SERVICE MANUAL

## Stereo Graphic Equalizer

### MODEL EQ-540

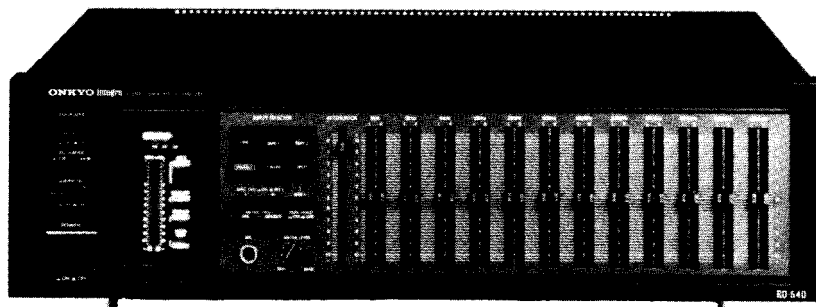

UD	120V AC, 60Hz
UW	120V/220V AC, 50Hz/60Hz
UQ	240V AC, 50Hz

#### SAFETY-RELATED COMPONENT WARNING!!

COMPONENTS IDENTIFIED BY MARK  $\Delta$  ON THE SCHEMATIC DIAGRAM AND IN THE PARTS LIST ARE CRITICAL FOR RISK OF FIRE AND ELECTRIC SHOCK. REPLACE THESE COMPONENTS WITH ONKYO PARTS WHOSE PARTS NUMBERS APPEAR AS SHOWN IN THIS MANUAL.

MAKE LEAKAGE-CURRENT OR RESISTANCE MEASUREMENTS TO DETERMINE THAT EXPOSED PARTS ARE ACCEPTABLY INSULATED FROM THE SUPPLY CIRCUIT BEFORE RETURNING THE APPLIANCE TO THE CUSTOMER.

#### TABLE OF CONTENTS

Specifications .....	2
Precautions .....	2
Adjustment procedures .....	3
Front panel facilities .....	4
IC Block diagram .....	5
Packing procedures .....	8
System connections .....	10
Printed board parts list .....	11
Chassis exploded view .....	14
Printed circuit board view .....	17
Block diagram .....	23
Schematic diagram .....	25

**ONKYO**<sup>®</sup>  
**AUDIO COMPONENTS**

# SPECIFICATIONS

## EQUALIZER SECTION

Input:	Sensitivity (FLAT): 150 mV
	Impedance: 50 kohms
Output:	Voltage (FLAT): 150 mV
	Impedance: 1 kohm
Max. output:	More than 5 V, 20 Hz – 20 kHz, 0,05% THD.
Frequency response:	+0/–0.5 dB, 10 Hz – 35 kHz
Total harmonic distortion:	Less than 0.01%, 20 Hz – 20 kHz, 1.5 V output (FLAT)
Signal to noise ratio:	100 dB, 1.5 V output, IHF-A, input short
Adjustable range:	±6 dB / ±12 dB
Gain:	0 dB to –20 dB

## OSCILLATOR SECTION

Step frequencies:	32 Hz, 64 Hz, 125 Hz, 250 Hz, 500 Hz, 1 kHz, 2 kHz, 4 kHz, 8 kHz, 16 kHz
Frequency response:	±1 dB, 32 Hz – 16 kHz
Output voltage:	150 mV

## MIC. AMP. SECTION

Input:	Sensitivity: 0.2 mV
	Impedance: 50 kohms
Frequency response:	+0/–1 dB, 20 Hz – 30 kHz
Max. input:	100 mV

## OTHERS

AC outlet:	200 watts (UNSWITCHED)
Power supply:	AC 120 V, 60 Hz
Dimensions:	435 (W) x 131 (H) x 362 (D) mm 17-1/8" x 5-3/16" x 14-1/4"
Weight:	5.7 kg, 12.6 lbs.

Specifications and features are subject to change without notice.

# PRECAUTIONS

### 1. Replacing the lamps

This unit uses the lamps listed below.

CIRCUIT NO.	PART NO.	DESCRIPTION
PL101	210195	PL-AS-EQ540

### 2. Insulation resistance measurement

Connect the insulating-resistance tester between the plug of power supply cable and the screw on the bottom board. Specifications; 500V, more than 10 M $\Omega$

### 3. Voltage selector (Rear panel)

Worldwide models are equipped with a voltage selector to conform with local power supplies.

Be sure to set this switch to match the voltage of the power supply in your area before turning the power switch on.

Voltage is changed by sliding the groove in the switch with a screwdriver to the right or left.

Confirm that the switch has been moved all the way to the right or left before turning the power switch on.

Models without a voltage selector can only be used in areas where the power supply is the same as that of the unit.

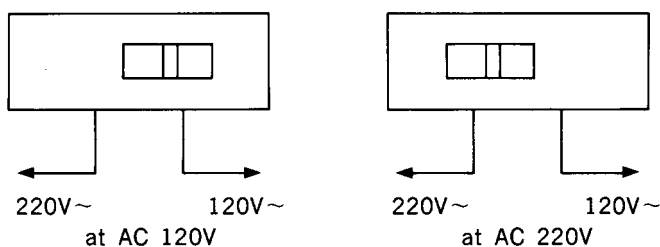

#### 4. Accessory microphone

##### Battery

The microphone is powered by a battery. Before using this microphone for the first time, insert the battery (included) as shown in the diagram. Whenever the microphone is not in use, be sure to set its ON/OFF switch to OFF.

In case the microphone is left ON, the average life of its battery is about 500 hours. The battery lasts from two to three years during ordinary use, but its life may be shorter due to frequent use or environmental conditions (temperature or humidity). If no microphone output can be obtained or noise is produced, please replace the battery with a new one conforming to the table below.

Type	Voltage	Size
Manganes	1.5 Volt	AA R6 UM-3

**Battery Replacement**

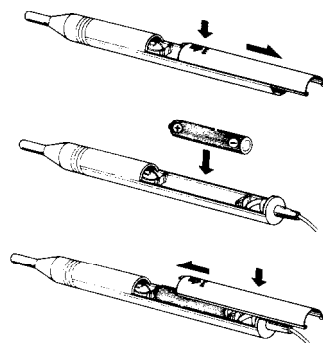

**Assembly of the stand**

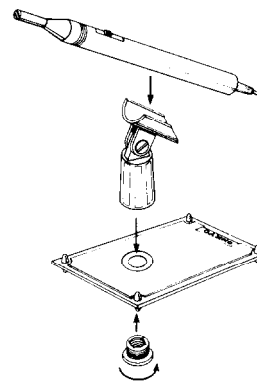

## ADJUSTMENT PROCEDURES

### 1. Preparation

#### Switch position

POWER.....	ON
EQUALIZER.....	OFF
EQ. RANGE.....	±12dB
SLIDER LED L, R.....	ON
INPUT SELECTOR.....	LINE
OSC. CH L, R.....	ON
METER INPUT.....	SOURCE
PEAK HOLD.....	OFF
METER LEVEL.....	MAXIMUM
ATTENUATOR.....	0 (MAXIMUM)
EQ. LEVEL.....	0 (CENTER)

### 2. Adjustment of level meter sensitivity

- Input a 1KHz, 15mV signal to LINE INPUT L.
- With the semi-fixed resistor VR401, align the indicator tube PEAK LEVEL meter to the "0" graduation. (Move up from below and stop at the position where the "0" section lights.)

### 3. Adjustment of the meter L, R deviation

- Input a 1KHz, 15mV signal to both L, R of LINE INPUT.
- With the semi-fixed resistor VR115, adjust the PEAK LEVEL meter indication until they are the same. (Adjust until the METER LEVEL movement up/down for L, R deviation is minimum.)

### 4. Adjustment of distortion of oscillator signal

- Set the INPUT SELECTOR to SPOT.
- Push the SHIFT shift to 1KHz.
- With the semi-fixed resistor VR302, adjust the oscillator output (above 150mV) so that the distortion factor is minimum.

### 5. Adjustment of WARBLE TONE

- After the adjustment of Item 4, turn ON the WARBLE switch.
- Adjust the semi-fixed resistor VR301 so that the center of the 1KHz waveform of the oscillator is the center of the abnormality.

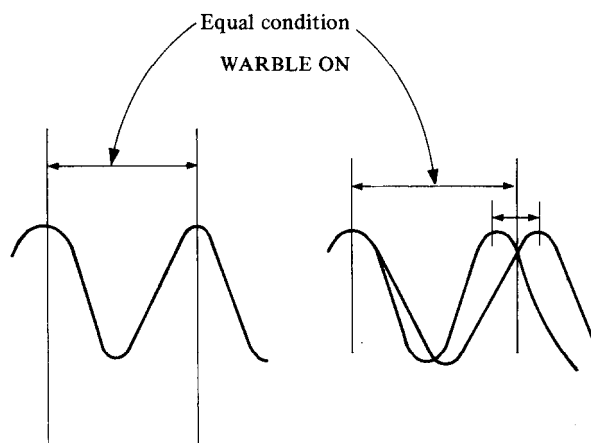

## Adjustment point

NAPS-3408-1

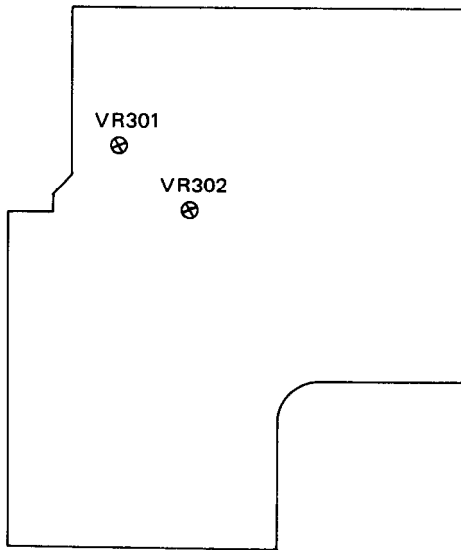

NAAF-3407-1

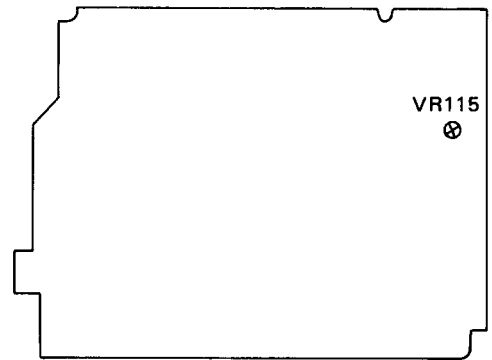

NADG-3411-1

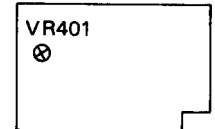

## FRONT PANEL FACILITIES

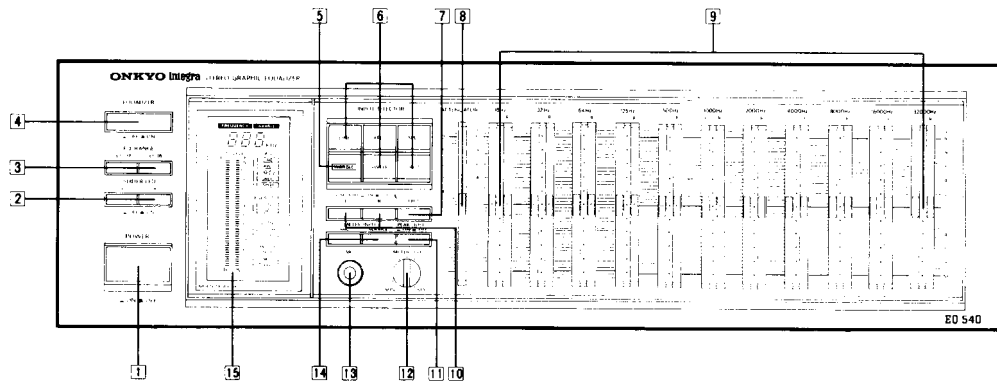

1. Power Switch and Indicator (POWER)
2. Level Controls and Attenuator Indicator Switches (SLIDER LED)
3. Equalizer Range Switch (EQ RANGE)
4. Equalizer Switch (EQUALIZER)
5. Warble Mods Switch (WARBLE)
6. Input Selector Switches (INPUT SELECTOR)  
LINE, TAPE-1, TAPE-2, SWEEP, SPOT
7. Spot Frequency Shift Switch (SHIFT)
8. Attenuator and Indicator (ATTENUATOR)
9. Level Controls and Indicators
10. Oscillator Channel Switches (OSC CH)
11. Peak Hold Switch (PEAK HOLD)
12. Meter Level Control (METER LEVEL)
13. Microphone Jack (MIC)
14. Level Meter Input Selectors (METER INPUT)  
SOURCE, MIC
15. Fluorescent Display (FREQUENCY, PEAK LEVEL, etc.)

# BLOCK DIAGRAM

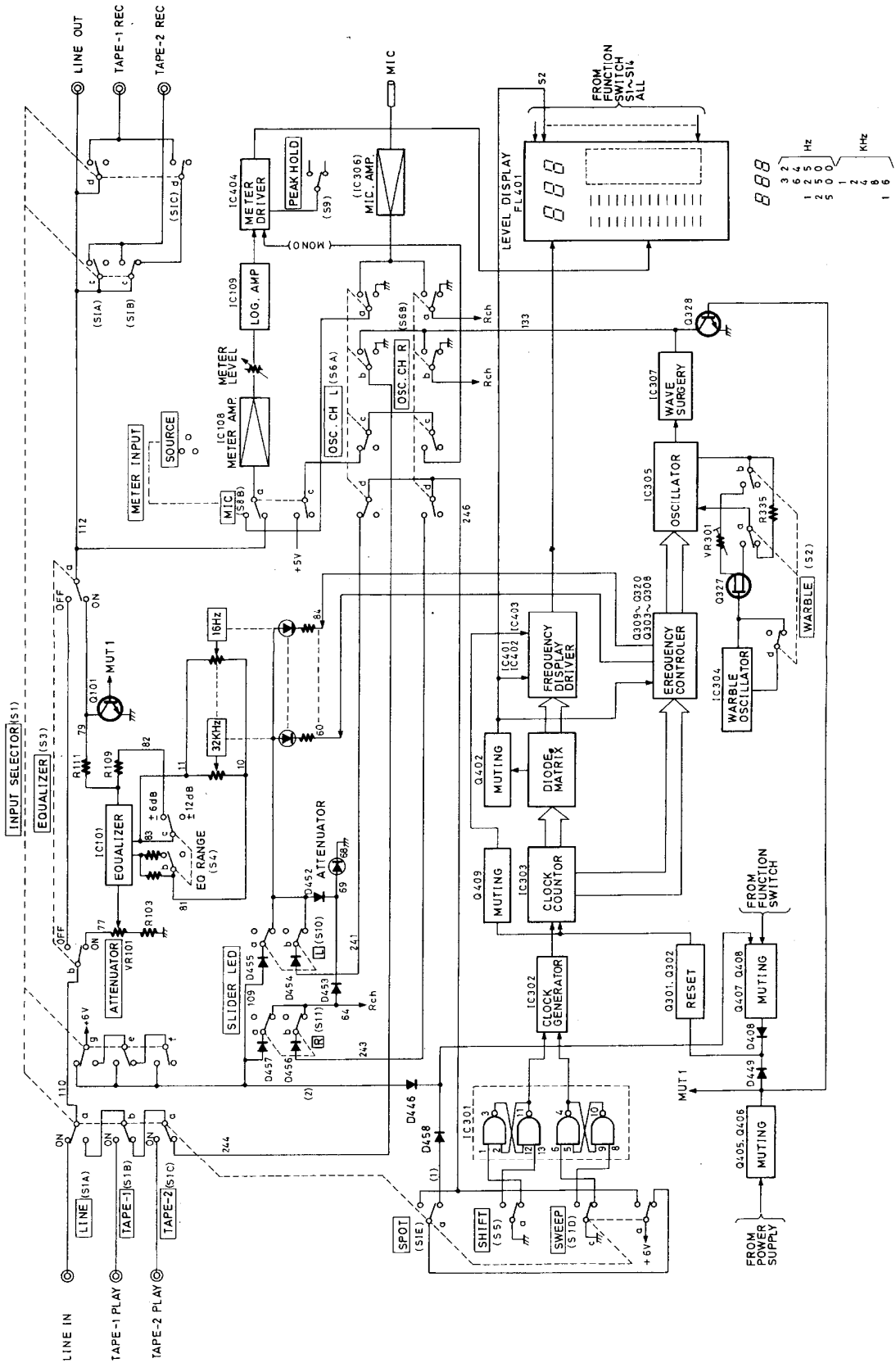

# CHASSIS-EXPLODED VIEW

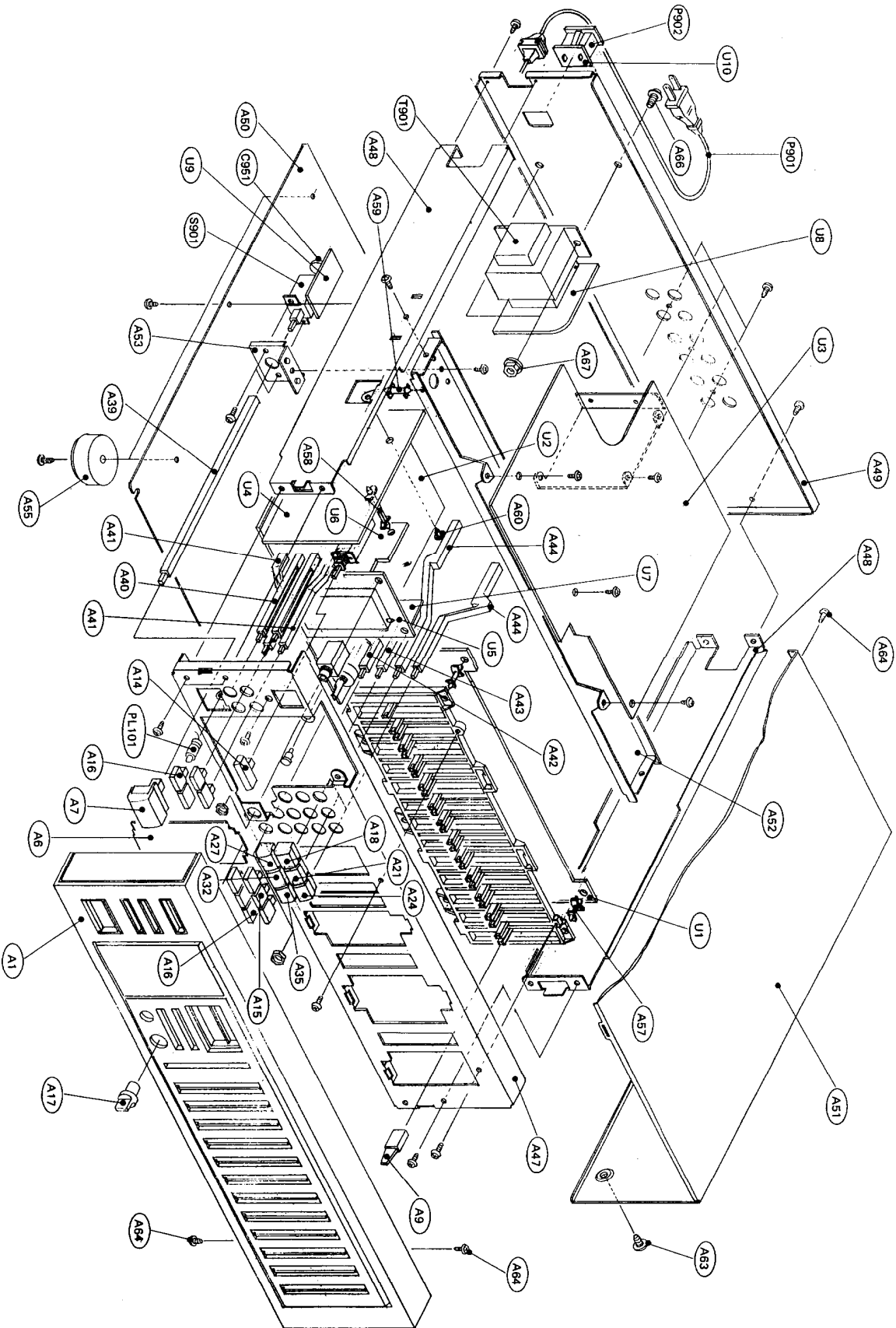

# SCHEMATIC DIAGRAM 2/2

(120V, 240V, 120V/220V Model)

1 2 3 4 5 6 7

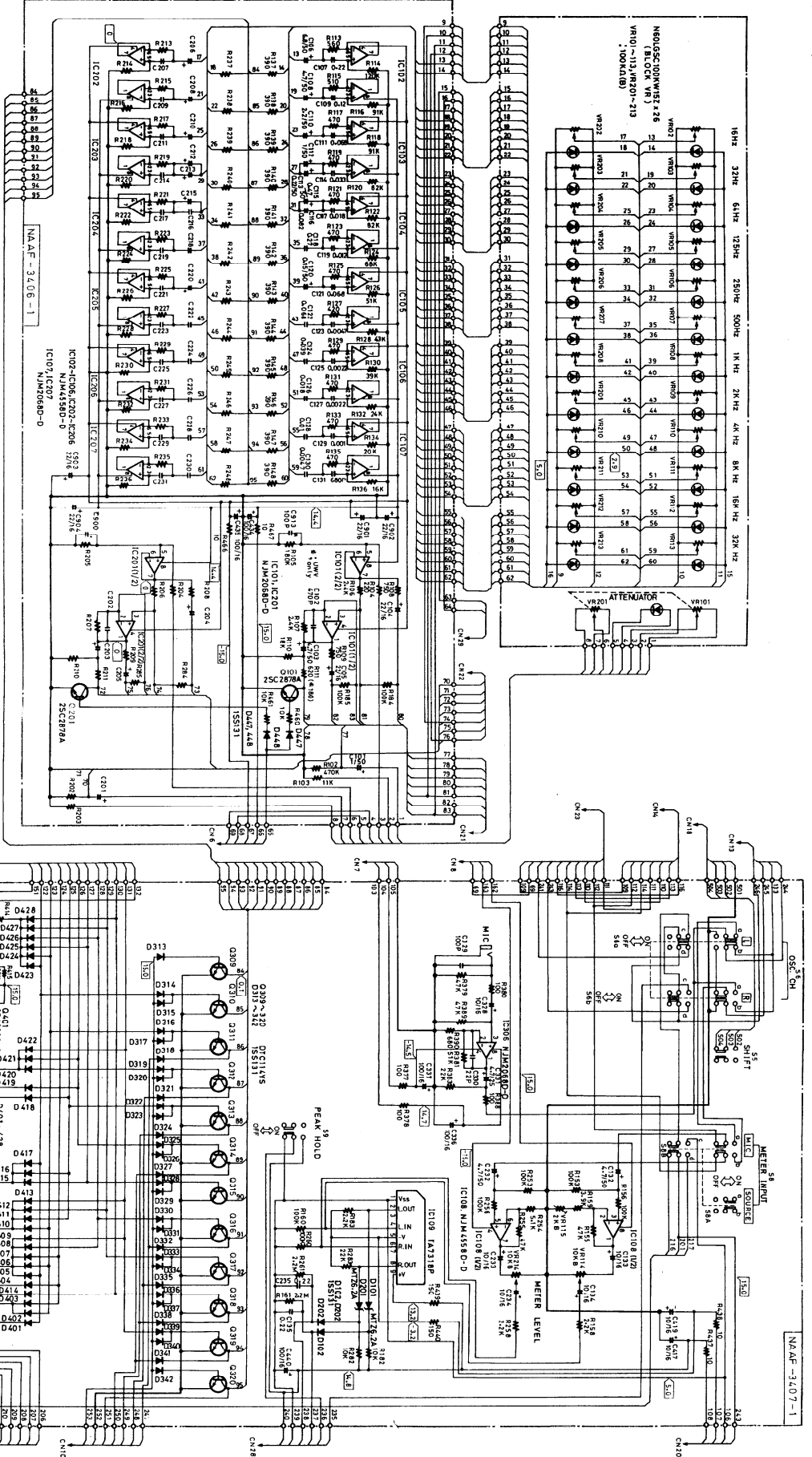

- NOTES**
- THE COMPONENTS IDENTIFIED BY MARK  $\Delta$  ARE CRITICAL FOR SAFETY.
  - REPLACE ONLY WITH PART NUMBER SPECIFIED.
  - VOLTAGE MEASURED WITH V.T.V.M.  $\square$  V IS DC VOLTAGE AND INPUT SIGNAL.
  - RESISTORS ARE IN OHMS UNLESS OTHERWISE NOTED.
  - ALL RESISTORS ARE 1/4 WATT UNLESS OTHERWISE NOTED.
  - CIRCUIT IS SUBJECT TO CHANGE FOR IMPROVEMENT.

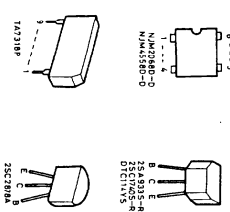

# SCHEMATIC DIAGRAM 1/2

(120V/220V Model)

1 2 3 4 5 6 7

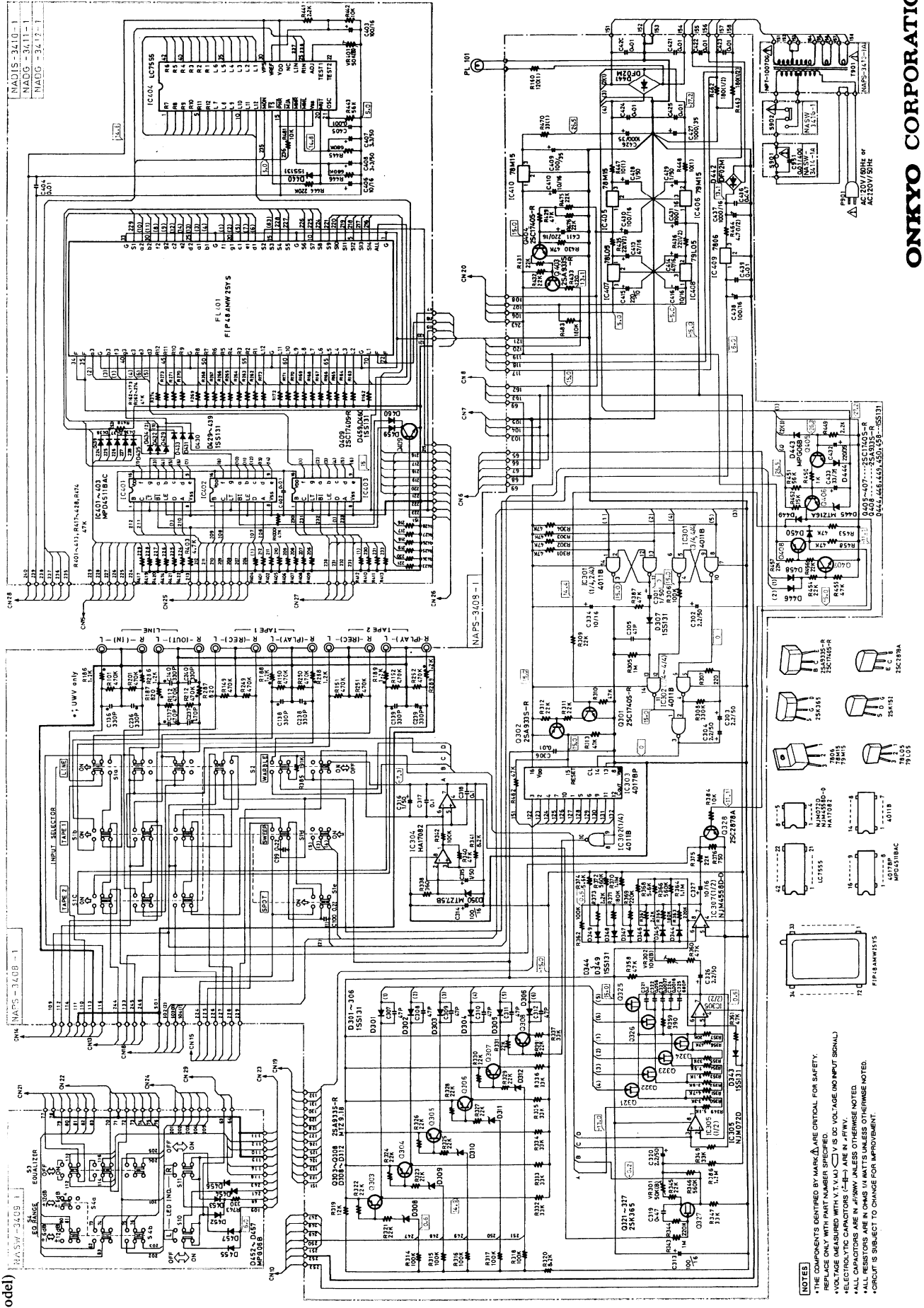

**NOTES**

- \*THE COMPONENTS IDENTIFIED BY MARK Δ ARE CRITICAL FOR SAFETY. REPLACE ONLY WITH PART NUMBER SPECIFIED.
- VOLTAGE MEASURED WITH SWITCH OPEN. VOLTAGE IN NO INPUT SIGNAL.
- RESISTOR VALUES IN Ω, kΩ, MΩ ARE IN P/P/W.
- ALL CAPACITORS ARE IN P/P/W UNLESS OTHERWISE NOTED.
- ALL RESISTORS ARE IN Ω/MΩ UNLESS OTHERWISE NOTED.
- CIRCUIT IS SUBJECT TO CHANGE FOR IMPROVEMENT.



# SCHEMATIC DIAGRAM 1/2

(120V, 240V Model)

1 2 3 4 5 6 7

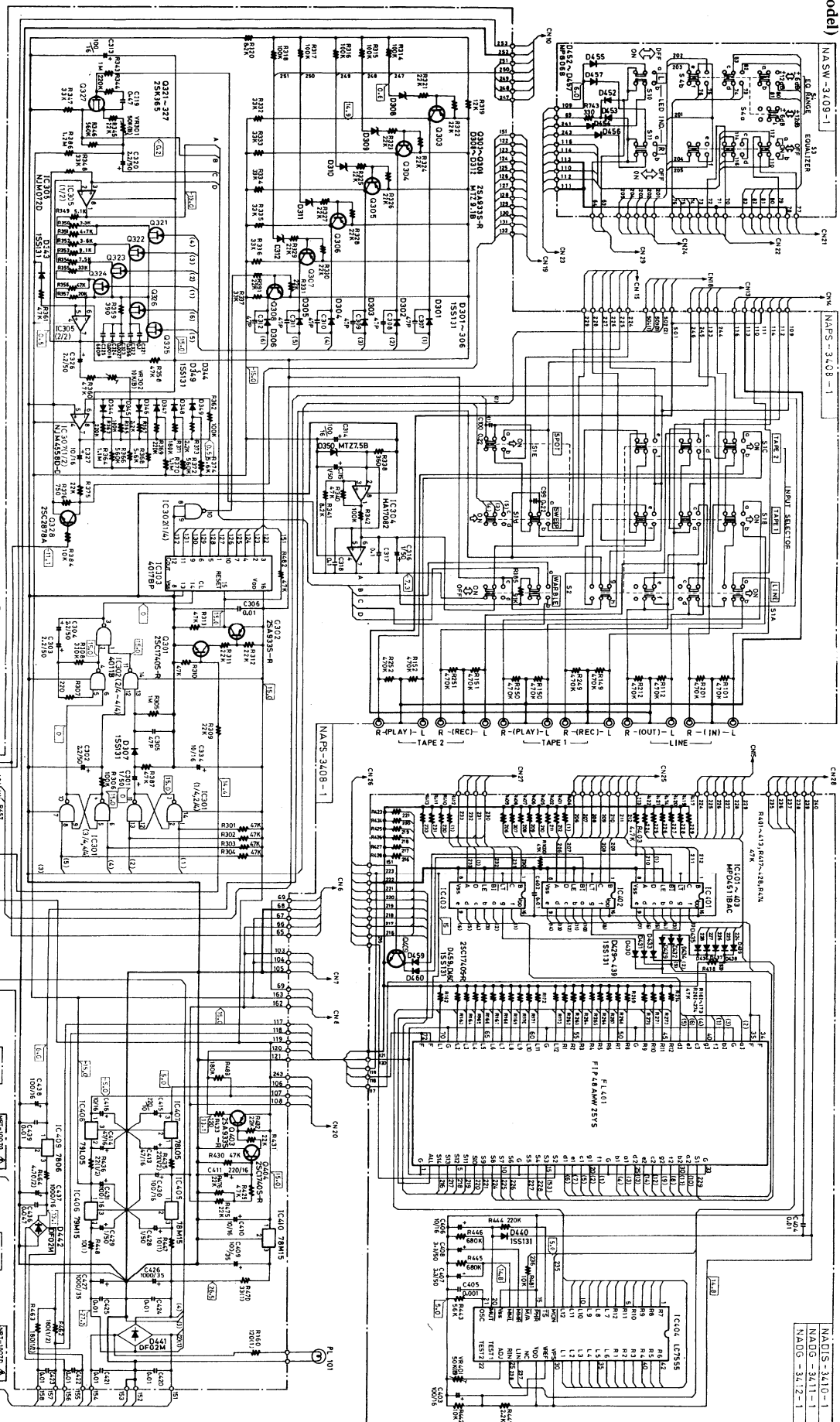

### NOTES

- \* THE COMPONENTS DESIGNATED BY MARK Δ ARE CRITICAL FOR SAFETY.
- † REFERENCE PART NUMBER SPECIFIED.
- ‡ ELECTRICAL CHARACTERISTICS IN PARTS LIST ARE FOR TYPICAL UNLESS OTHERWISE NOTED.
- § ALL CAPACITORS ARE IN pF UNLESS OTHERWISE NOTED.
- ¶ ALL RESISTORS ARE IN OHMS UNLESS OTHERWISE NOTED.
- \*\* SLOTTED IS SUBJECT TO CHANGE FOR IMPROVEMENT.

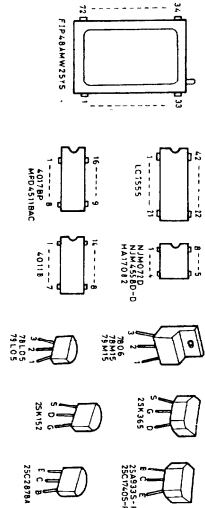

ONKYO CORPORATION

## IC BLOCK DIAGRAM

4011 (2-Input NAND Gate)

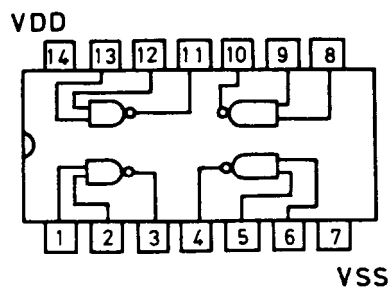

NJM2068DD (Operational Amplifier)  
 NJM4558DD  
 NJM072D  
 HA17082

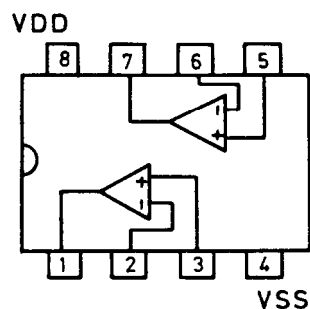

4017  
 (Decade Counter with  
 10 Decoded Output)

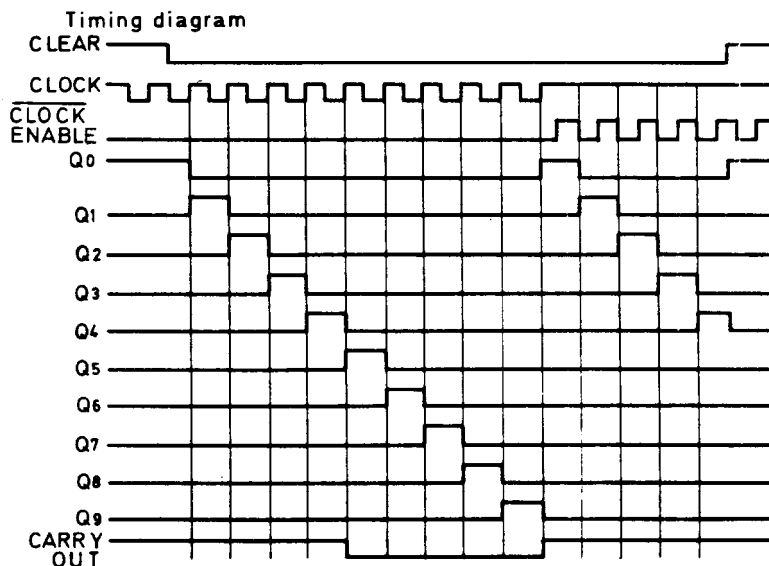
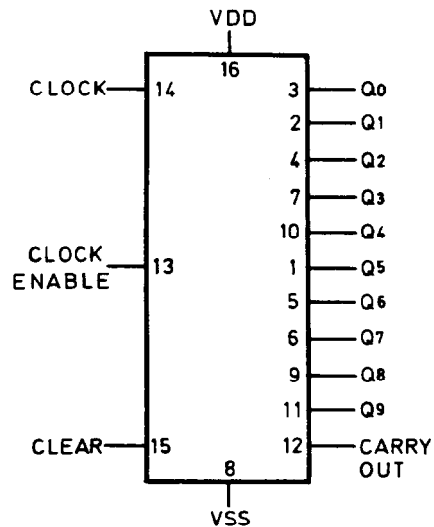

TA7318P (Meter Driver)

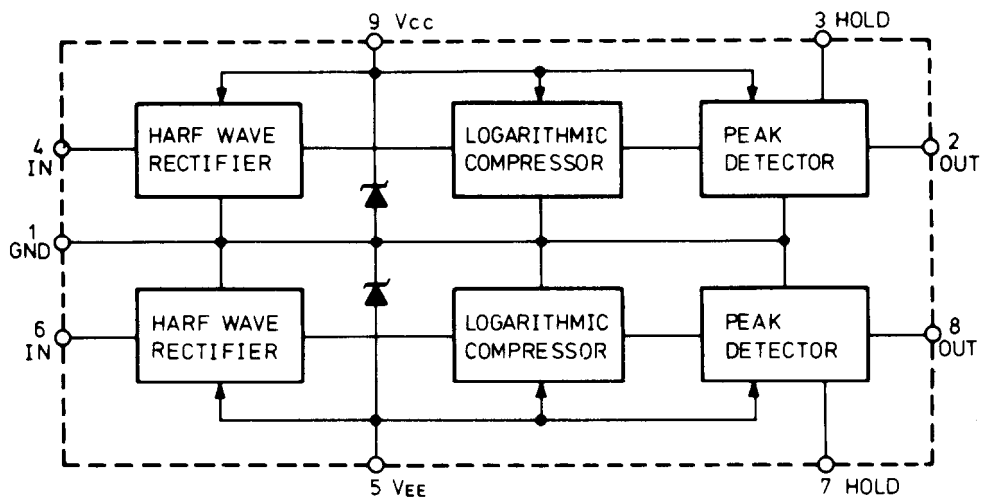

LC7555 (Peak Holding Level Meter)

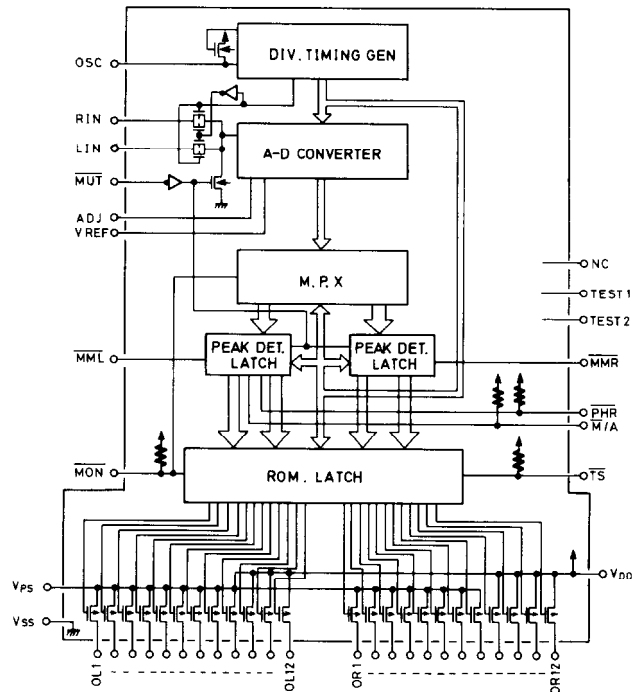
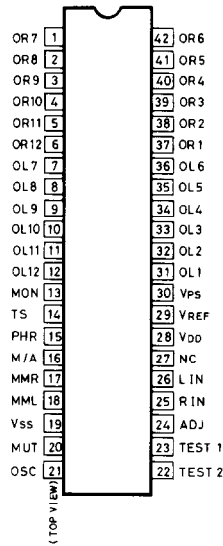

μPD4511BAC (BCD-to Seven Segment Driver)

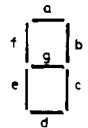
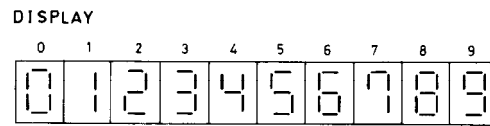
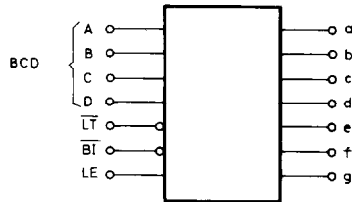
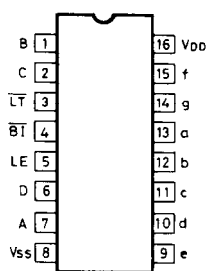

TRUTH TABLE

INPUT							OUTPUT							DISPLAY
LE	BT	LT	D	C	B	A	a	b	c	d	e	f	g	
X	X	L	X	X	X	X	H	H	H	H	H	H	H	8
X	L	H	X	X	X	X	L	L	L	L	L	L	L	BLANK
L	H	H	L	L	L	L	H	H	H	H	H	H	L	0
L	H	H	L	L	L	H	L	H	H	L	H	H	L	1
L	H	H	L	L	H	L	H	H	L	H	H	L	H	2
L	H	H	L	L	H	H	H	H	H	L	L	H	H	3
L	H	H	L	H	L	L	L	H	H	L	L	H	H	4
L	H	H	L	H	L	H	H	L	H	H	L	H	H	5
L	H	H	L	H	H	L	H	L	H	H	H	H	H	6
L	H	H	L	H	H	H	H	H	H	L	L	H	L	7
L	H	H	H	L	L	L	H	H	H	H	H	H	H	8
L	H	H	H	L	L	H	H	H	H	H	L	H	H	9
L	H	H	H	L	H	L	L	L	L	L	L	L	L	BLANK
L	H	H	H	L	H	H	L	L	L	L	L	L	L	BLANK
L	H	H	H	H	L	L	L	L	L	L	L	L	L	BLANK
L	H	H	H	H	L	H	L	L	L	L	L	L	L	BLANK
L	H	H	H	H	H	L	L	L	L	L	L	L	L	BLANK
L	H	H	H	H	H	H	L	L	L	L	L	L	L	BLANK
H	H	H	X	X	X	X								

H: HIGH LEVEL L: LOW LEVEL X: Hor L

FIP48AMW25YS (Fluorescent Tube)

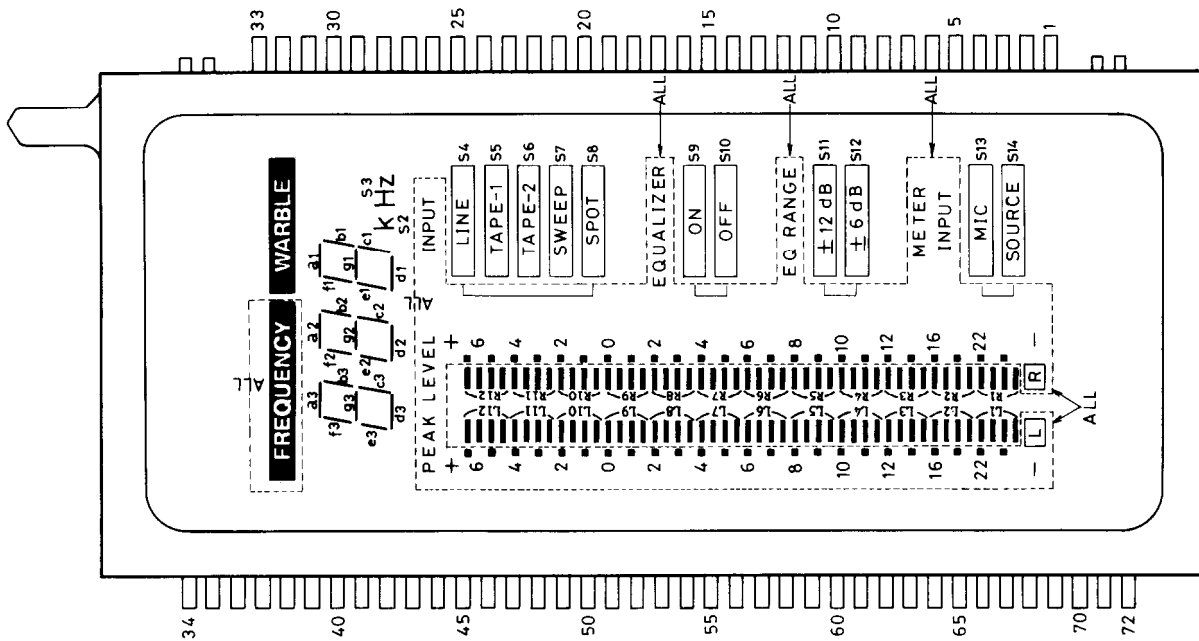

TERMINAL NO.	1	2	3	4	5	6	7	8	9	10
ELECTRODE	G	ALL	P	P	P	P	P	P	P	P
			S14	S13	S12	S11	S10	S9	S8	S7
TERMINAL NO.	11	12	13	14	15	16	17	18	19	20
ELECTRODE	P	G	P	P	P	P	P	P	P	P
	S6		S5	S4	S3	S2	d1	e1	c1	g1
TERMINAL NO.	21	22	23	24	25	26	27	28	29	30
ELECTRODE	P	G	P	P	P	P	P	P	P	P
	f1		b1	a1	d2	e2	c2	g2	f2	b2
TERMINAL NO.	31	32	33	34	35	36	37	38	39	40
ELECTRODE	P	P	G	F	F	F	G	P	P	P
	a2	S1			a3			b3	f3	g3
TERMINAL NO.	41	42	43	44	45	46	47	48	49	50
ELECTRODE	P	P	P	P	P	P	P	G	P	P
	c3	e3	d3	R12	R11	R10	R9		R8	R7
TERMINAL NO.	51	52	53	54	55	56	57	58	59	60
ELECTRODE	P	P	P	P	P	P	P	G	P	P
	R6	R5	R4	R3	R2	R1	L12		L11	L10
TERMINAL NO.	61	62	63	64	65	66	67	68	69	70
ELECTRODE	P	P	P	P	P	P	P	P	G	P
	L9	L8	L7	L6	L5	L4	L3	L2		L1
TERMINAL NO.	71	72								
ELECTRODE	F	F								

# PACKING PROCEDURES

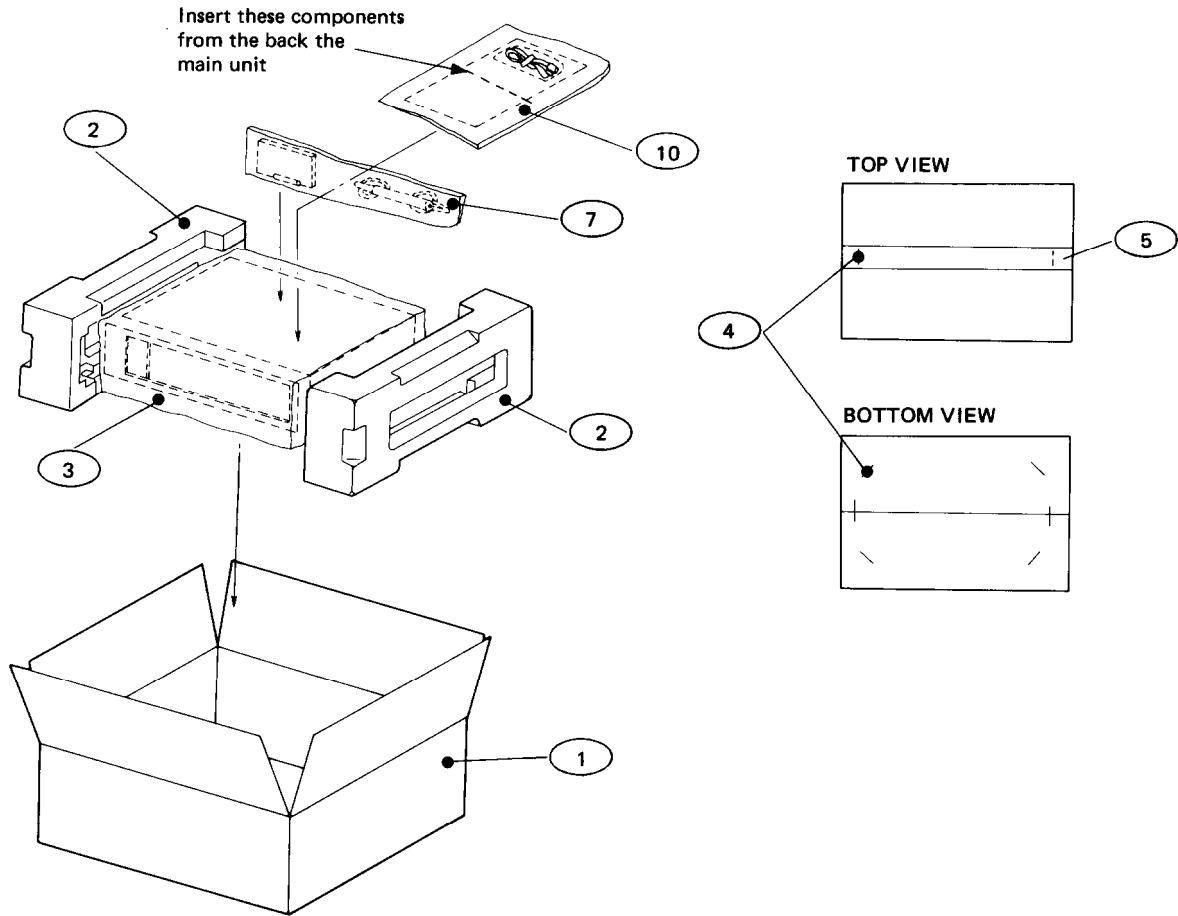

REF. NO.	PART NO.	DESCRIPTION
1	29051731	MASTER CARTON BOX
2	29091283	PAD
3	29100104	POLY-VINYL BAG
4	282301	SEALING HOOK
5	260012	W=50 mm, DAMPLON TAPE
10	ACCESSORY BAG ASS'Y	
	29341287	INSTRUCTION MANUAL [D]
	29341288	INSTRUCTION MANUAL [W][V][Q]
	29341297	INSTRUCTION MANUAL, I [W][V]
	29358002F	SERVICE STATION LIST [N]
	29365019	WARRANTY CARD [N]
	29365020	WARRANTY CARD [V]
	29365022	WARRANTY CARD [Q]
	29100006A	350 x 250, POLY-VINYL BAG
	2010112	CONNECTION CABLE
	25055040	CV-K-2, CONVERSION PLUG [W]
7	24190008	MICROPHONE ASS'Y

## NOTE

- [D]: ONLY 120V MODEL
- [V]: ONLY 220V MODEL
- [W]: ONLY 120V/220V MODEL
- [Q]: ONLY 240V MODEL

## Only military market model

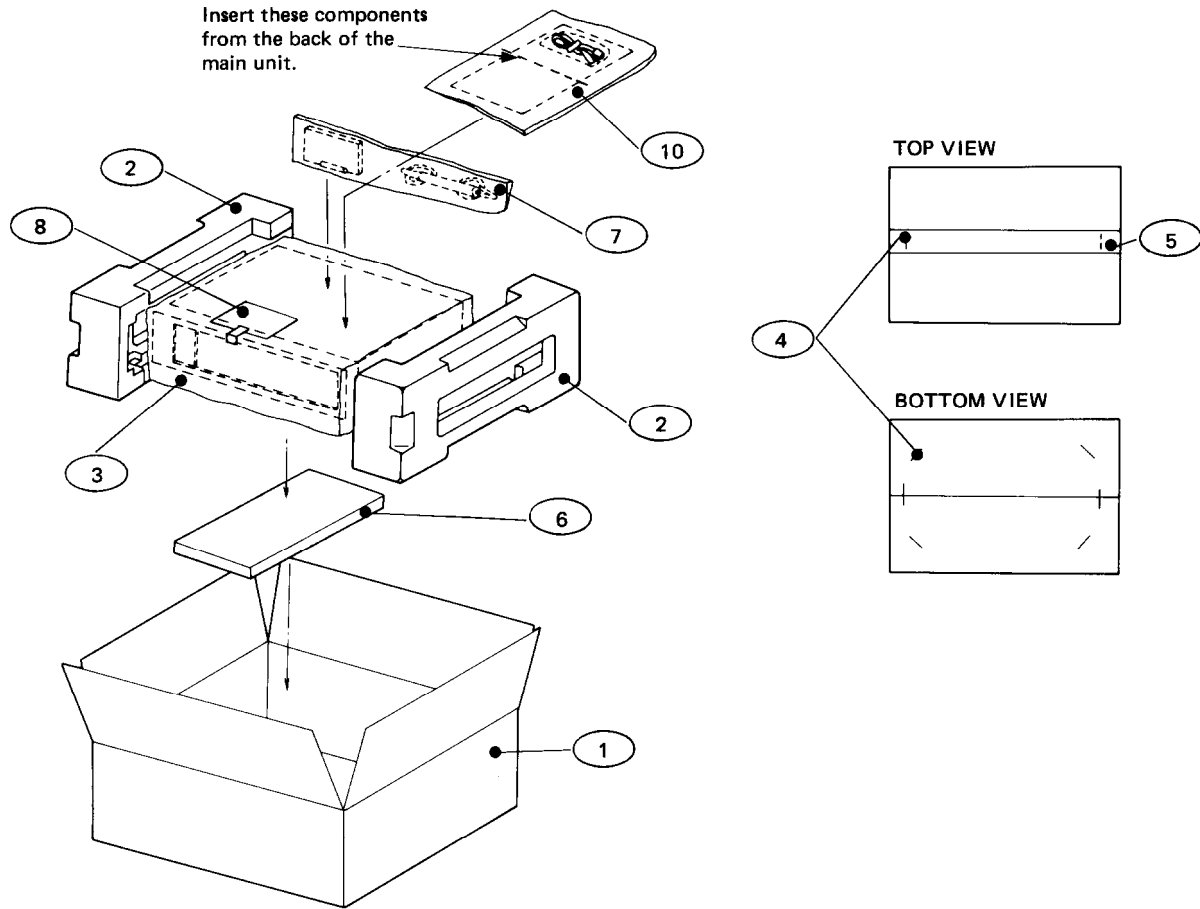

REF. NO.	PART NO.	DESCRIPTION	REF. NO.	PART NO.	DESCRIPTION
1	29051767	MASTER CARTON BOX	8	29380084	CAUTION (120) [XD]
2	29091283	PAD	8	29380085	CAUTION (220) [XG]
3	29100104	POLY-VINYL BAG			
4	282301	SEALING HOOK			
5	260012	W=50 mm, DAMPLON TAPE			
6	—	SIDE BOARD			
(6)	28185344	SIDE BOARD (L)			
(6)	28185345	SIDE BOARD (R)			
(6)	836440303	4STV+30CQBC, SCREW			
(6)	870086	4 × 12BSBC, SPECIAL WASHER			
(6)	29341018-1	INSTRUCTION MANUAL			
(6)	29051732	CARTONBOX			
(6)	29095539	PROTECTION SHEET			
(6)	29095039-1	PROTECTION SHEET			
(6)	29100026	POLY-VINYL BAG			
	29360815	LABEL (120), AC CABLE [XD]			
	29360816	LABEL (220), AC CABLE [XG]			
10	ACCESSORY BAG ASS'Y				
	29341288	INSTRUCTION MANUAL			
	29358002F	SERVICE STATION LIST			
	29365021	WARRANTY CARD			
	29100006A	350 x 250, POLY-VINYL BAG			
	2010112	CONNECTION CABLE			
	2505251	CV-CP, CONVERSION PLUG			
7	24190008	MICROPHONE ASS'Y			

## NOTE

[XD]: ONLY 120V MODEL  
[XG]: ONLY 220V MODEL

Only military market model

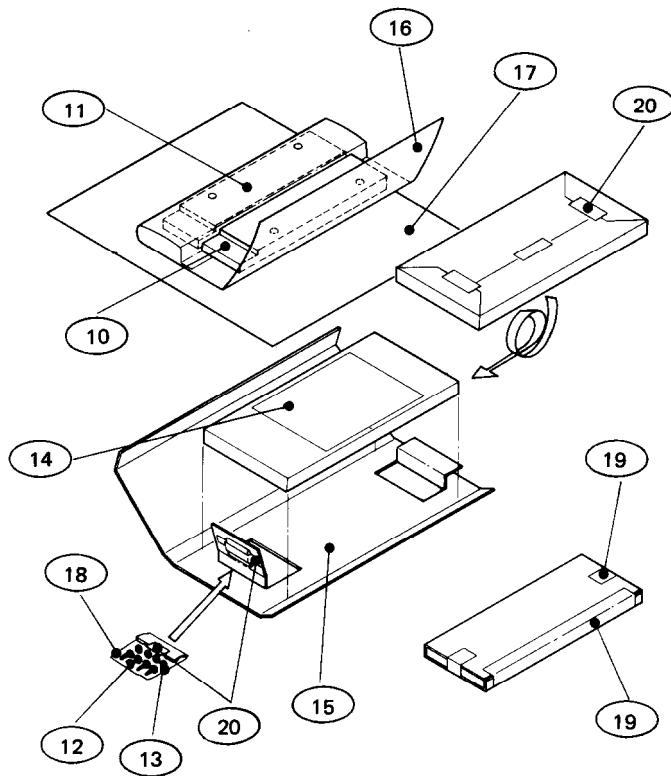

REF. NO.	PART NO.	DESCRIPTION
10	28185344	Side board ass'y, left
11	28185345	Side board ass'y, right
12	836440303	4STV+30CQBC, Screw
13	870086	4 × 12BSBC, Special washer
14	29341018-1	Instruction manual
15	29051732	Carton box
16	29095539	580 × 400mm, Protection sheet
17	29095039-1	600 × 500mm, Protection sheet
18	29100026	Poly-vinyl bag
19	260012	Damplon tape
20	262005	Cellophane tape

## SYSTEM CONNECTIONS

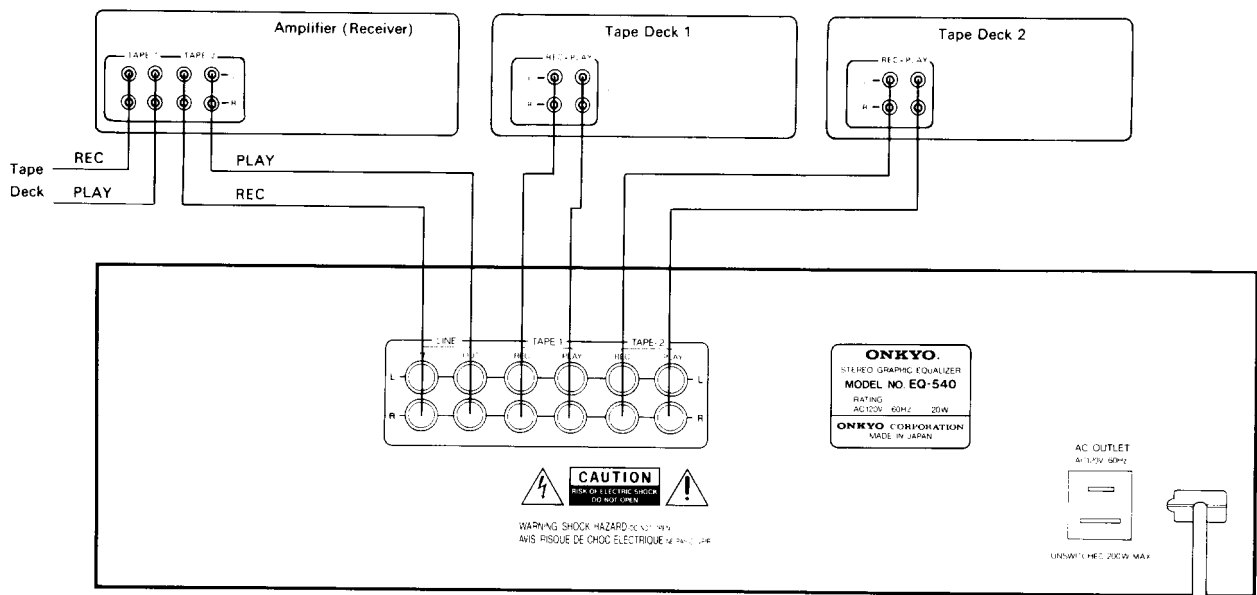

Do not plug in the power cord until all connections have been made.

# PRINTED CIRCUIT BOARD PARTS LIST

## EQUALIZER CIRCUIT PC BOARD (NAAF-3406-1,NAAF-3406-1A) PARTS LIST

CIRCUIT NO.	PART NO.	DESCRIPTION
<b>ICs</b>		
IC101,IC107	222956	NJM2068DD
IC201,IC207		
IC102 ~ IC106	222811	NJM4558DD
IC202 ~ IC206		
<b>Transistors</b>		
Q101,Q201	2212285	2SC2878A
<b>Diodes</b>		
D447,D448	223172	1SS131
<b>Capacitors</b>		
C101,C112	354780109	1 $\mu$ F, 50V, Elect.
C201,C212		
C102,C202	370134714	470 pF, 100V, Film (APS)
C103,C203	354780479	4.7 $\mu$ F, 50V, Elect.
C104,C105	354742209	22 $\mu$ F, 16V, Elect.
C204,C205		
C106,C206	354780689	6.8 $\mu$ F, 50V, Elect.
C107,C207	371122245	0.22 $\mu$ F, 50V, Mylar
C108,C208	354780479	4.7 $\mu$ F, 50V, Elect.
C109,C209	371121245	0.12 $\mu$ F, 50V, Mylar
C110,C210	354780229	2.2 $\mu$ F, 50V, Elect.
C111,C211	371126835	0.68 $\mu$ F, 50V, Mylar
C113,C213	354782299	0.22 $\mu$ F, 50V, Elect.
C114,C214	371123335	0.033 $\mu$ F, 50V, Mylar
C115,C215	354784799	0.47 $\mu$ F, 50V, Elect.
C116,C216	371128235	0.082 $\mu$ F, 50V, Mylar
C117,C217	371121835	0.018 $\mu$ F, 50V, Mylar
C118,C218	371122745	0.27 $\mu$ F, 50V, Mylar
C119,C219	371121235	0.012 $\mu$ F, 50V, Mylar
C120,C220	354781599	0.15 $\mu$ F, 50V, Elect.
C121,C221	371126825	6800 pF, 50V, Mylar
C122,C222	371126835	0.068 $\mu$ F, 50V, Mylar
C123,C223	371124725	4700 pF, 50V, Mylar
C124,C224	371123935	0.039 $\mu$ F, 50V, Mylar
C125,C127	371122225	2200 pF, 50V, Mylar
C225,C227		
C126,C226	371121835	0.018 $\mu$ F, 50V, Mylar
C128,C228	371121035	0.01 $\mu$ F, 50V, Mylar
C129,C229	371121025	1000 pF, 50V, Mylar
C130,C230	371124725	4700 pF, 50V, Mylar
C131,C231	370136814	680 pF, 100V, Film (APS)
C901~C904	354742209	22 $\mu$ F, 16V, Elect.

### Jumper socket

25050140	NJPJ-3P-S
25050142	NJPJ-5P-S
25050144	NJPJ-7P-S
25050149	NJPJ-12P-S

## EQUALIZER SWITCH AND MIC CIRCUIT PC BOARD (NAAF-3407-1) PARTS LIST

CIRCUIT NO.	PART NO.	DESCRIPTION
<b>ICs</b>		
IC108	222811	NJM4558DD
IC109	222509	TA7318P
IC306	222956	NJM2068DD

CIRCUIT NO.	PART NO.	DESCRIPTION
<b>Transistors</b>		
Q309~Q320	221281	DTC114YS
Q401	2213354	2SA933SR
Q402	2213284	2SC1740SR
<b>Diodes</b>		
D101,D201	224450621	MTZ6.2A, Zener
D102,D202	223172	1SS131
D313~D342		
D401~D428		
<b>Capacitors</b>		
C132,C232	354780479	4.7 $\mu$ F, 50V, Elect.
C133,C134	354741009	10 $\mu$ F, 16V, Elect.
C233,C234		
C328,C417		
C419		
C331	354754709	4.7 $\mu$ F, 25V, Elect.
C336,C337	354741019	100 $\mu$ F, 16V, Elect.
C440		
<b>Resistors</b>		
VR114,VR214	5104244	N16RGL10KB202
VR115	5210155	N06HR2KBD, Semi-fixed variable
<b>Switches</b>		
S5,S6	25035593	NPS-162-142-222-L555
S8,S9	25035594	NPS-142-222-L556
<b>MIC Jack</b>		
	25045241	MIC-JACK-EQ540
<b>Plugs</b>		
	25055418	NPLG-5P400
	25055419	NPLG-6P401
	25055420	NPLG-10P402

## MAIN PC BOARD (NAPS-3408-1,NAPS-3408-1A) PARTS LIST

CIRCUIT NO.	PART NO.	DESCRIPTION
<b>ICs</b>		
IC301,IC302	222840111	4011B
IC303	222840171	4017BP
IC304	22240195	HA17082
IC305	222735	NJM072D
IC307	222811	NJM4558DD
IC405,IC410	222780151	78M15
IC406	222790151	79M15
IC407	222780053	78L05
IC408	222790053	79L05
IC409	222780060	7806

### Transistors

Q301	2213284	2SC1740SR
Q404~Q407		
Q302~Q308	2213354	2SA933SR
Q403,Q408		
Q321~Q327	2212445	2SK365GR
Q328	2212285	2SC2878A



CIRCUIT NO.	PART NO.	DESCRIPTION
D301~D307 D343~D349 D444,D446 D449,D450 D458 D308~D312 D350 D441,D442 D443 D445	<b>Diodes</b> 223172  224450912 224450752 223892 22380025 224451601	1SS131  MTZ9.1B, Zener MTZ7.5B, Zener DF02M MPG06B MTZ16A, Zener
C136,C138 C139,C140 C236,C238 C239,C240 C137,C237 C301,C315 C316 C302~C304 C326,C320 C313,C314 C317,C318 C321 C319 C322 C323 C324 C325 C327,C334 C410,C416 C409 C411 C413,C414 C415 C426,C427 C428,C429 C430,C431 C432 C433 C437 C438	<b>Capacitors</b> 370133314  370134714 354780109  354780229  354741019 371121045  371124745 371125635 371122725 371121825 370136814 354741009  354761019 354742219 354744709 354732219 354761029 354780109 354741019 354762219 354763309 354741029 354741019	330 pF, 100V, Film (APS) [V]  470 pF, 100V, Film (APS) [V] 1 $\mu$ F, 50V, Elect.  2.2 $\mu$ F, 50V, Elect.  100 $\mu$ F, 16V, Elect. 0.1 $\mu$ F, 50V, Mylar  0.47 $\mu$ F, 50V, Mylar 0.056 $\mu$ F, 50V, Mylar 2700 pF, 50V, Mylar 1800 pF, 50V, Mylar 680 pF, 100V, Film (APS) 10 $\mu$ F, 16V, Elect.  100 $\mu$ F, 35V, Elect. 220 $\mu$ F, 16V, Elect. 47 $\mu$ F, 16V, Elect. 220 $\mu$ F, 10V, Elect. 1000 $\mu$ F, 35V, Elect. 1 $\mu$ F, 50V, Elect. 100 $\mu$ F, 16V, Elect. 220 $\mu$ F, 35V, Elect. 33 $\mu$ F, 35V, Elect. 1000 $\mu$ F, 16V, Elect. 100 $\mu$ F, 16V, Elect.
VR301 VR302 R160 R435,R436 R447,R448 R462,R463 R464 R470	<b>Resistors</b> 5210153 5210154 441621214 442522204 441621004 442521814 441524704 441623304	N06HR50KBD, Semi-fixed N06HR10KBD, Semi-fixed 120 $\Omega$ , 1W, Metal oxide film 22 $\Omega$ , 1/2W, Metal oxide film 10 $\Omega$ , 1W, Metal oxide film 180 $\Omega$ , 1/2W, Metal oxide film 47 $\Omega$ , 1/2W, Metal oxide film 33 $\Omega$ , 1W, Metal oxide film
S1	<b>Switch</b> 25035595	NPS-182-ETC-L557
	<b>Input terminal</b> 25045242	NPJ-4PDBL-115
	<b>Jumper sockets</b> 25050140 25050141 25050142 25050143 25050144 25050149	NJPJ-3P-S NJPJ-4P-S NJPJ-5P-S NJPJ-6P-S NJPJ-7P-S NJPJ-12P-S

CIRCUIT NO.	PART NO.	DESCRIPTION
	<b>Radiator</b> 27160232	RAD-79

## EQUALIZER SWITCH PC BOARD (NASW-3409-1) PARTS LIST

CIRCUIT NO.	PART NO.	DESCRIPTION
D452~D457	<b>Diodes</b> 22380025	MPG06B
S3 S4	<b>Switches</b> 25035597 25035596	NPS-162-L559 NPS-162-322-L558
	<b>Sockets</b> 25050374 25050376	NSCT-5P201 NSCT-10P203

## FL TUBE PC BOARD (NADIS-3410-1) PARTS LIST

CIRCUIT NO.	PART NO.	DESCRIPTION
FL101	<b>FL Tube</b> 212060	FIP48AMW25YS
IC403	<b>IC</b> 22240186	MPD4511BAC
D429,D430 D432~D439	<b>Diodes</b> 223172	1SS131

## FL DRIVER CIRCUIT PC BOARD (NADG-3411-1) PARTS LIST

CIRCUIT NO.	PART NO.	DESCRIPTION
IC404	<b>IC</b> 22240187	LC7555
D440	<b>Diode</b> 223172	1SS131
C403 C406 C407,C408	<b>Capacitors</b> 354741019 354741009 354780339	100 $\mu$ F, 16V, Elect. 10 $\mu$ F, 16V, Elect. 3.3 $\mu$ F, 50V, Elect.
VR401 RA402,RA403	<b>Resistors</b> 5210152 49123473408	N06HR50KBE, Semi-fixed RM1/8GJ 47K $\times$ 8, Resistor network
	<b>Socket</b> 25050375	NSCT-6P202

## FL DRIVER CIRCUIT PC BOARD (NADG-3412-1) PARTS LIST

CIRCUIT NO.	PART NO.	DESCRIPTION
IC401,IC402	<b>ICs</b> 22240186	MPD4511BAC
Q409	<b>Transistor</b> 2213284	2SC1740SR
D431,D459	<b>Diodes</b> 223172	1SS131

CIRCUIT NO.	PART NO.	DESCRIPTION
	<b>Resistors</b>	
RA401,RA404	49123473408	RM1/8GJ 47K × 8, Resistor network
	<b>Socket</b>	
	25050376	NSCT-10P203

**POWER TRANSFORMER PC BOARD (NAPS-3413-1,NAPS-3413-1A,NAPS-3413-1B) PARTS LIST**

CIRCUIT NO.	PART NO.	DESCRIPTION
	<b>Transformer</b>	
T901	2300354	NPT-1007D [D]
	2300356	NPT-1007DG [V][W][X]
	2300357	NPT-1007Q [Q]
	<b>Capacitor</b>	
C952	3500077	DE7150F472M
	<b>Cover(capacitor)</b>	
	27300601	SB-1925 [V][W][X][Q]
	<b>Jumper socket</b>	
	25050145	NJPJ-8P-S
	<b>Plug</b>	
	25055421	NPLG-2P403

**POWER SWITCH PC BOARD (NASW-3414-1,NASW-3414-1A) PARTS LIST**

CIRCUIT NO.	PART NO.	DESCRIPTION
	<b>Capacitor</b>	
C951	3500065A	DE7150FZ103P
	<b>Cover(capacitor)</b>	
	27300601	SB-1925 [V][W][X][Q]
	<b>Switch</b>	
S901	25035598	NPS-111-L560P

**AC SOCKET PC BOARD (NAETC-3415-1) PARTS LIST**

CIRCUIT NO.	PART NO.	DESCRIPTION
	<b>Socket</b>	
P902	25050316	NSCT-2P143T, AC Outlet

**VOLTAGE SELECTOR (NAETC-3416-1) PARTS LIST**

CIRCUIT NO.	PART NO.	DESCRIPTION
	<b>Switch</b>	
S902	25065228	NSS-2299, Slide

**NOTE**

- [X]: Only Military market model
- [V]: Only West germany model
- [D]: Only 120V Model
- [W]: Only 120V/220V Model
- [Q]: Only 240V Model

## CHASSIS EXPLODED VIEW PART LIST

REF. NO.	PART NO.	DESCRIPTION	REF. NO.	PART NO.	DESCRIPTION
A1	27211005	FRONT PANEL ASS'Y	△P902	25050316	NSCT-2P143T, AC SOCKET
(A2)	27215143	GUIDE PANEL	PL101	210195	PL-AS-EQ540, LAMP
(A3)	28125194-1	END CAP, LEFT	U1	1W025506-1	NAAF-3406-1, EQUALIZER CIRCUIT PC BOARD ASS'Y
(A4)	28125195-1	END CAP, RIGHT		1W025506-1A	NAAF-3406-1A, EQUALIZER CIRCUIT PC BOARD ASS'Y
(A5)	28191481	FRONT FILTER			
(A6)	28133206	COLOR FILTER			
(A8)	28198714	FACET			
A7	28323175	KNOB (POW)	U2	1W025507-1	NAAF-3407-1, EQUALIZER SWITCH AND MIC CIRCUIT PC BOARD ASS'Y
A9	28323451	KNOB ASS'Y (GE)			
A14	28323453	KNOB (EQ)	U3	1W025508-1	NAPS-3408-1, MAIN PC BOARD ASS'Y
A15	28323454	KNOB, (MODE-C)		1W025508-1A	NAPS-3408-1A, MAIN PC BOARD ASS'Y [V]
A16	28323455	KNOB, (MODE-H)	U4	1W025509-1	NASW-3409-1, EQUALIZER SWITCH PC BOARD ASS'Y
A17	28323456	KNOB (LEV)			
A18	28323457	KNOB ASS'Y (LINE)			
A21	28323460	KNOB ASS'Y (TAPE-1)	U5	1W025510-1	NADIS-3410-1, FL TUBE PC BOARD ASS'Y
A24	28323462	KNOB ASS'Y (TAPE-2)	U6	1W025511-1	NADG-3411-1, FL DRIVER CIRCUIT PC BOARD ASS'Y
A27	28323464	KNOB ASS'Y (WARBLE)	U7	1W025512-1	NADG-3412-1, FL DRIVER CIRCUIT PC BOARD ASS'Y
A32	28323466	KNOB ASS'Y (SWEEP)	U8	1W025513-1	NAPS-3413-1, POWER TRANSFORMER PC BOARD ASS'Y [D]
A35	28323468	KNOB ASS'Y (SPOT)		1W025513-1A	NAPS-3413-1A, POWER TRANSFORMER PC BOARD ASS'Y [V][W][X]
A39	27273102	JOINT (A)		1W025513-1B	NAPS-3413-1B, POWER TRANSFORMER PC BOARD ASS'Y [A][B]
A40	27273103	JOINT (B)	U9	1W025514-1	NASW-3414-1, POWER SWITCH PC BOARD ASS'Y
A41	27273104	JOINT (C)		1W025514-1A	NASW-3414-1A, POWER SWITCH PC BOARD ASS'Y [V][W][X][A][B]
A42	27273105	JOINT (D)	U10	1W025515-1	NAETC-3415-1, AC SOCKET PC BOARD ASS'Y [D][V][W][X]
A43	27273106	JOINT (E)	U11	1W025516-1	NASW-3416-1, VOLTAGE SELECTOR SWITCH PC BOARD ASS'Y [W]
A44	27273107	JOINT (F)			
A47	27110442	FRONT BRACKET			
A48	27115238	SIDE BRACKET			
A49	27121156	REAR PANEL [D]			
	27121157	REAR PANEL [W][X]			
	27121158	REAR PANEL [V]			
	27121159	REAR PANEL [A][B]			
A50	27170252	BOTTOM PLATE			
A51	28184397Z	TOP COVER			
A52	27130553	CENTER BRACKET			
A53	27190660	SWITCH HOLDER			
A55	27175153	BOTTOM LEG			
A57	27190688	PC HOLDER			
A58	27190689	PC HOLDER			
A59	27190690	PC HOLDER			
A60	880019	Revet			
A63	8384440087	4TTB + 8SBC, TAP-TIGHT SCREW			
A64	838430088	3TTB + 8BBC, TAP-TIGHT SCREW			
A66	831140087	4TTW+8S, TAP-TIGHT SCREW			
A67	86414010	FWN4×10FN, FLANGE NUT			
VR101 ~ VR113	6170001	N60LGSC100KW15Z × 26, SLIDE VARIABLE RESISTOR			
VR201 ~ VR213					
△P901	253153	AS-EQ540UD, POWER SUPPLY CABLE [D][X]			
	253154	AS-EQ540UW, POWER SUPPLY CABLE [V][W]			
	253155	AS-EQ540UQA, POWER SUPPLY CABLE [A]			
	253156	AS-EQ540UQB, POWER SUPPLY CABLE [B]			
△T901	2300354	NPT-1007D, POWER TRANSFORMER			
	2300356	NPT-1007DG, POWER TRANSFORMER [V][G][W][X]			
	2300357	NPT-1007Q, POWER TRANSFORMER [A][B]			
△S901	25035598	NPS-111-L560P, POWER SWITCH			
△S902	25065228	NSS-2299, SLIDE SWITCH			
△C951	3500065A	0.01μF, CAPACITOR			

## NOTE

- [X]: ONLY MILITARY MARKET MODEL  
[V]: ONLY WEST GERMANY MODEL  
[A]: ONLY AUSTRALIAN MODEL  
[B]: ONLY BRITISH MODEL  
[D]: ONLY 120V MODEL  
[W]: ONLY 120V/220V MODEL

NOTE: THE COMPONENTS IDENTIFIED BY MARK △ ARE CRITICAL FOR RISK OF FIRE AND ELECTRIC SHOCK. REPLACE ONLY WITH PARTS NUMBER SPECIFIED.