

ONKYO SERVICE MANUAL

CD/MD TUNER AMPLIFIER MODEL FR-N3X

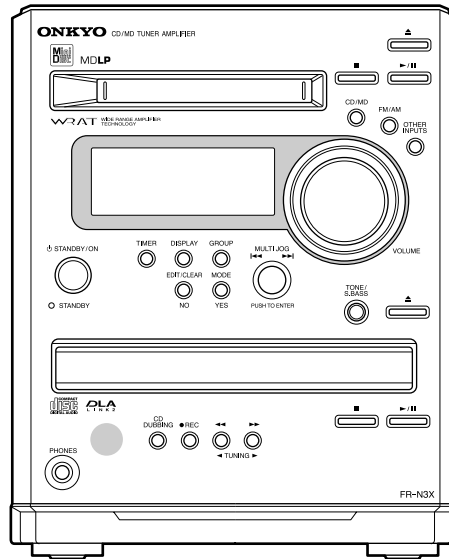

Silver model

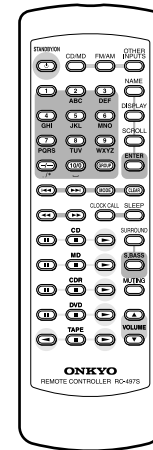

RC-497S

UDT	120V AC, 60Hz
UGQ,UGR,UGT	220-230V AC, 50/60Hz

SAFETY-RELATED COMPONENT WARNING!!

COMPONENTS IDENTIFIED BY MARK \triangle ON THE SCHEMATIC DIAGRAM AND IN THE PARTS LIST ARE CRITICAL FOR RISK OF FIRE AND ELECTRIC SHOCK. REPLACE THESE COMPONENTS WITH ONKYO PARTS WHOSE PART NUMBERS APPEAR AS SHOWN IN THIS MANUAL.

MAKE LEAKAGE-CURRENT OR RESISTANCE MEASUREMENTS TO DETERMINE THAT EXPOSED PARTS ARE ACCEPTABLY INSULATED FROM THE SUPPLY CIRCUIT BEFORE RETURNING THE APPLIANCE TO THE CUSTOMER.

SPECIFICATIONS

General

Power supply	AC 220-230 V, 50/60 Hz AC 120 V, 60 Hz
Power consumption	46 W (220-230 V, 50/60 Hz) 55 W (120 V, 60 Hz)
(Standby)	1.5 W
Clock precision	monthly error: +/- 30 seconds (at 25 degrees Celsius)
Dimensions (W×H×D)	155×190×361 mm
Weight	4.7 kg

Amplifier

Power output	2×18 W at 4 Ω EIAJ 2×15 W at 6 Ω EIAJ Rated Power 2×13W min, RMS at 4 Ω 1 kHz no more than 0.4 % THD
Dynamic power	2×14 W at 4 Ω
Total harmonic distortion	0.4 % at rated power
IM distortion	0.4 % at rated power
Damping factor	25 at 8 Ω
Sensitivity and impedance	
LINE, CDR/TAPE:	300 mV, 50 k
CDR/TAPE:	300 mV, 50 k
Frequency response	10 to 100,000 Hz : +3.5, -3dB
Tone control	
S.BASS	+10 dB at 50 Hz
Bass	120 Hz
	7 positions (-7, -5, -2.5, 0, +2.5, +5, +7 dB)
Trable	10 kHz
	7 positions (-7, -5, -2.5, 0, +2.5, +5, +7 dB)
Signal to noise ratio	LINE, CDR/TAPE: 100dB (IHF-A)
Muting	50 dB

CD player

Signal readout system	Optical non-contact
Frequency response	10 Hz to 20 kHz (± 2 dB)
Wow and flutter	Below threshold of measurability

MD recorder

Signal readout system	Optical non-contact
Frequency response	10 Hz to 20 kHz (± 2 dB)
Wow and flutter	Below threshold of measurability

Tuner

Tuning range	FM: 87.50 to 108.00 MHz (50 kHz steps) AM: 522 to 1611 kHz (9 kHz steps)
Usable sensitivity	FM Mono:11.2 dBf, 1.0 μV (75 Ω IHF) Stereo:17.2 dBf, 2.0 μV (75 Ω IHF) AM: 30 μV
50 dB quieting sensitivity	FM Mono:17.2 dBf, 2.0μV (75 Ω) Stereo:37.2 dBf, 20.0 μV (75 Ω)
Capture ratio	2.0 dB
Image rejection ratio	FM: 85 dB AM: 40 dB
IF rejection ratio	FM: 90 dB AM: 40 dB
Signal to noise ratio	FM Mono : 72 dB IHF Stereo : 67 dB IHF AM: 40 dB
Selectivity	FM: 50 dB (±300 kHz at 40 kHz devi.)
Harmonic distortion	FM: Mono: 1.0 % Stereo: 0.3 % AM: 0.7 %
Frequency response	FM: 30 to 15,000 Hz (±1.5 dB)
Stereo separation	FM: 45 dB at 1,000 Hz FM: 30 dB at 100 to 10,000 Hz

Specifications and features are subject to change without notice.

EXPLODED VIEW

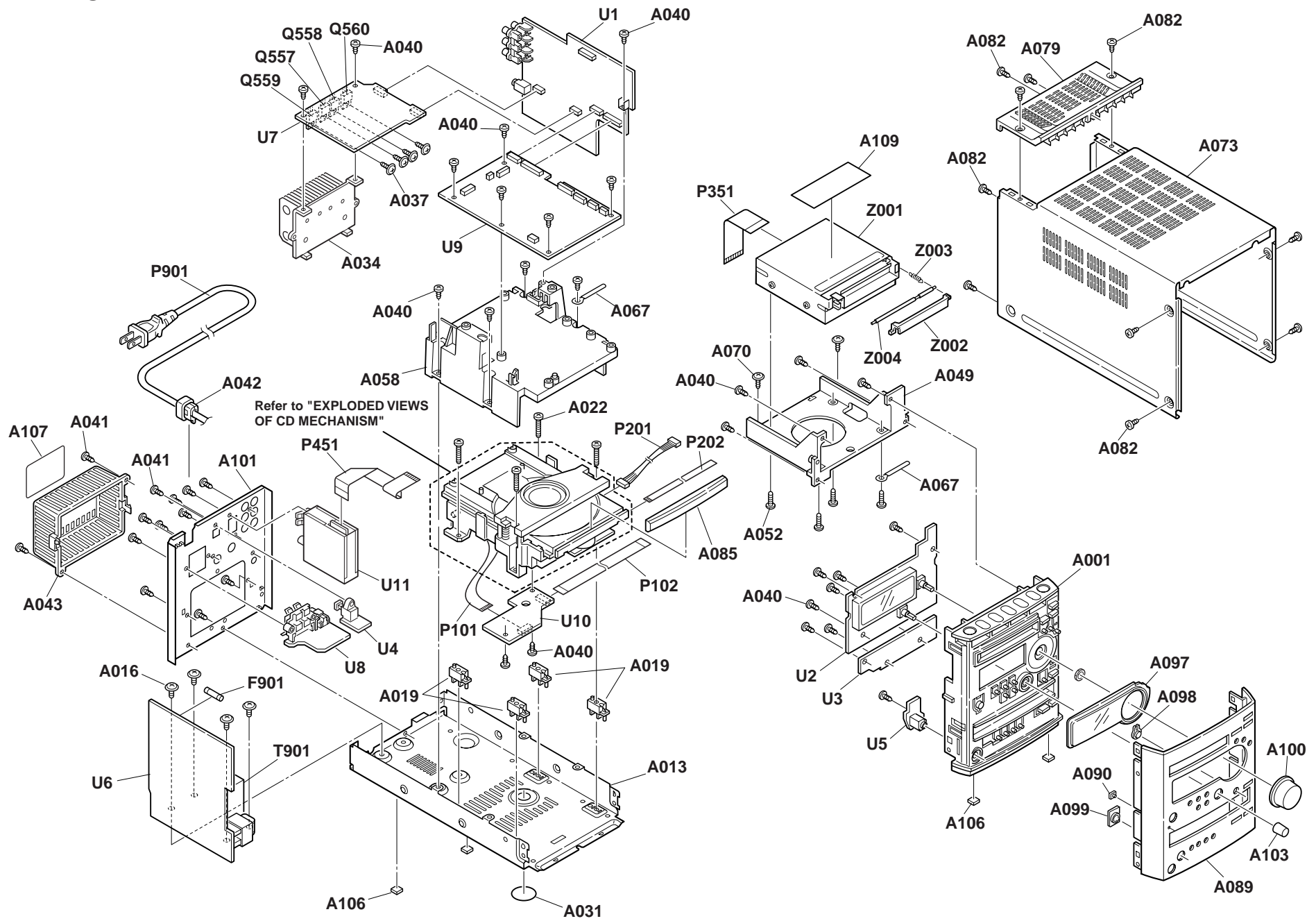

SERVICE PROCEDURES

PROTECTION OF EYES FROM LASER BEAM DURING SERVICING

This set employs a laser. Therefore, be sure to follow carefully the instructions below when servicing.

WARNING!!

SERVICE WARNING : DO NOT APPROACH THE LASER EXIT WITH THE EYE TOO CLOSELY.

IN CASE IT IS NECESSARY TO CONFIRM LASER BEAM EMISSION, BE SURE TO OBSERVE FROM A DISTANCE OF MORE THAN 30cm FROM THE SURFACE OF THE OBJECTIVE LENS ON THE OPTICAL PICK-UP BLOCK.

Laser Diode Properties

Material: GaAS/GaALAs

Wavelength: 780nm

Laser output: max. 0.5mW*

Emission Duration: continuous

*This output is the value measured at a distance about 1.8mm from the objective lens surface on the Optical Pick-up Block.

LASER WARNING LABEL

The label shown below are affixed.

1. Warning label



2. Class 1 label





**LUOKAN 1
LASERLAITE
KLASS 1
LASER APPARAT**

SERVICE PROCEDURE

1. Replacing the fuses

 This symbol located near the fuse indicates that the fuse used is show operating type. For continued protection against fire hazard, replace with same type fuse , For fuse rating, refer to the marking adjust to the symbol.

 Ce symbole indique que le fusible utilise est e lent. Pour une protection permanente, n'utiliser que des fusibles de meme type. Ce demier est indique la qu le present symbol est appose.

REF.NO.	PART NO.	DESCRIPTION
F901A	252158	 1.6A-UL/T-237, Fuse <DT>
	252083	 0.4A-SE-EAK, Fuse <GT,GR,GQ>

NOTE : <DT> : 120 V model only
<GT,GR,GQ> : 220 - 230 V models only

2. How to initialize the unit

- (1) Press and the hold down the **CD STOP** button , then press the **STANDBY/ON** button.
- (2) All segment light up and character scroll, the preset memory and each mode stored in the memory, are initialized and will return to the factory settings.
- (3) Press the **STANDBY/ON** button.
- (4) Disconnect the AC power supply cord from a wall outlet.

3. How to check version of MD mechanism microprocessor?

- (1) Connect the AC power supply cord to a wall outlet.
- (2) Press **STANDBY/ON** to turn on the unit.
- (3) Press **CD/MD** to select the "**MD**" position, and Change into the state of "**No Disc**".
- (4) Press **MODE/YES** as pressing down **DISPLAY**.
Microprocessor version on the FI display
Ex. "**020328 EXX-a**"
- (5) Disconnect the AC power supply cord from a wall outlet.

4. How to check version of Main microprocessor(Q701) and Sub microprocessor(Q801)?

- (1) Connect the AC power supply cord to a wall outlet.
Pushing **STANDBY/ON** is continued at operation of (2) and (3).
- (2) Press **STANDBY/ON** as pressing down **MULTI JOG**.
Main-microprocessor version on the FI display
Ex. "**Main 020327A**"
- (3) Press **STANDBY/ON** as pressing down **MULTI JOG**.
Sub-microprocessor version on the FI display
Ex. "**Sub 020227A**"
- (4) Disconnect the AC power supply cord from a wall outlet.

5. Change the band step

R703	R704	R705	R706	R707	R708	AM Band step
NC	10k	NC	10k	NC	10k	9kHz
10k	NC	NC	10k	NC	10k	10kHz

NC:No connection

EXPLODED VIEW OF MECHANISM (MD) -1

MD MECHANISM : KMK-260EEO

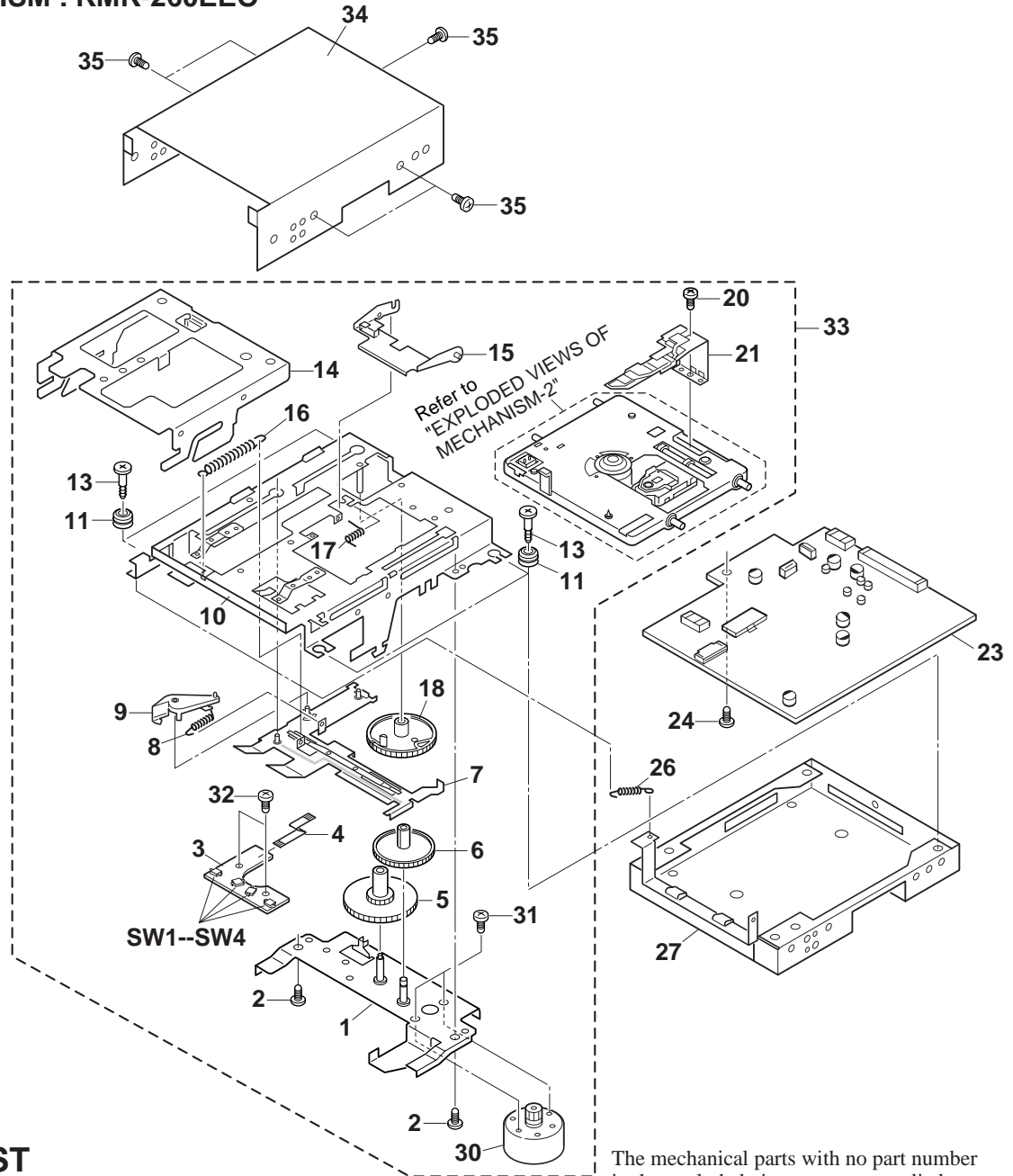

PARTS LIST

REF NO.	PART NO.	DESCRIPTION	REF NO.	PART NO.	DESCRIPTION
1	---	Motor Plate ass'y	17	2646-561-01	Spring, SP Tension
2	7685-791-01	Screw +PTT2.6 x 5 (S)	18	2646-560-02	Cam, Mode
3	---	L-SW Mount 2	20	2627-529-01	Grip (+P1.7 x 2.5 Type2)
4	1792-100-31	Flexible flat cable (5 core)	21	8620-021-71	MD Over write head
5	2646-555-02	Gear (Relay B)	23	---	MD mount PC board
6	2646-554-01	Gear (Relay A)	24	7685-791-09	Screw +PTT2.6 x 5 (S)
7	X2646-726-1	Frame ass'y, slot	26	2646-545-01	Spring (Door arm), Tension coil
8	2646-563-01	Spring (Slot arm), Tension coil	27	---	Case (Lower)
9	2646-556-01	Slot Arm	30	X2626-328-1	Loading motor ass'y
10	---	Frame ass'y, Road	31	7627-852-38	Precision screw (+P1.7 x 1.8 Type 3)
11	2646-548-01	Insulator	32	7685-780-01	Screw +PTT2 x 3 (S)
13	2647-337-01	Screw, Step	33	---	Loading ass'y
14	---	Frame, Slide	34	---	Case (Upper)
15	2646-559-02	Arm, head	35	7621-259-25	Screw (+P2.6 x 4)
16	2646-562-01	Spring, Tension coil			

EXPLODED VIEW OF MECHANISM (MD) -2

MD MECHANISM : KMK-260EEO

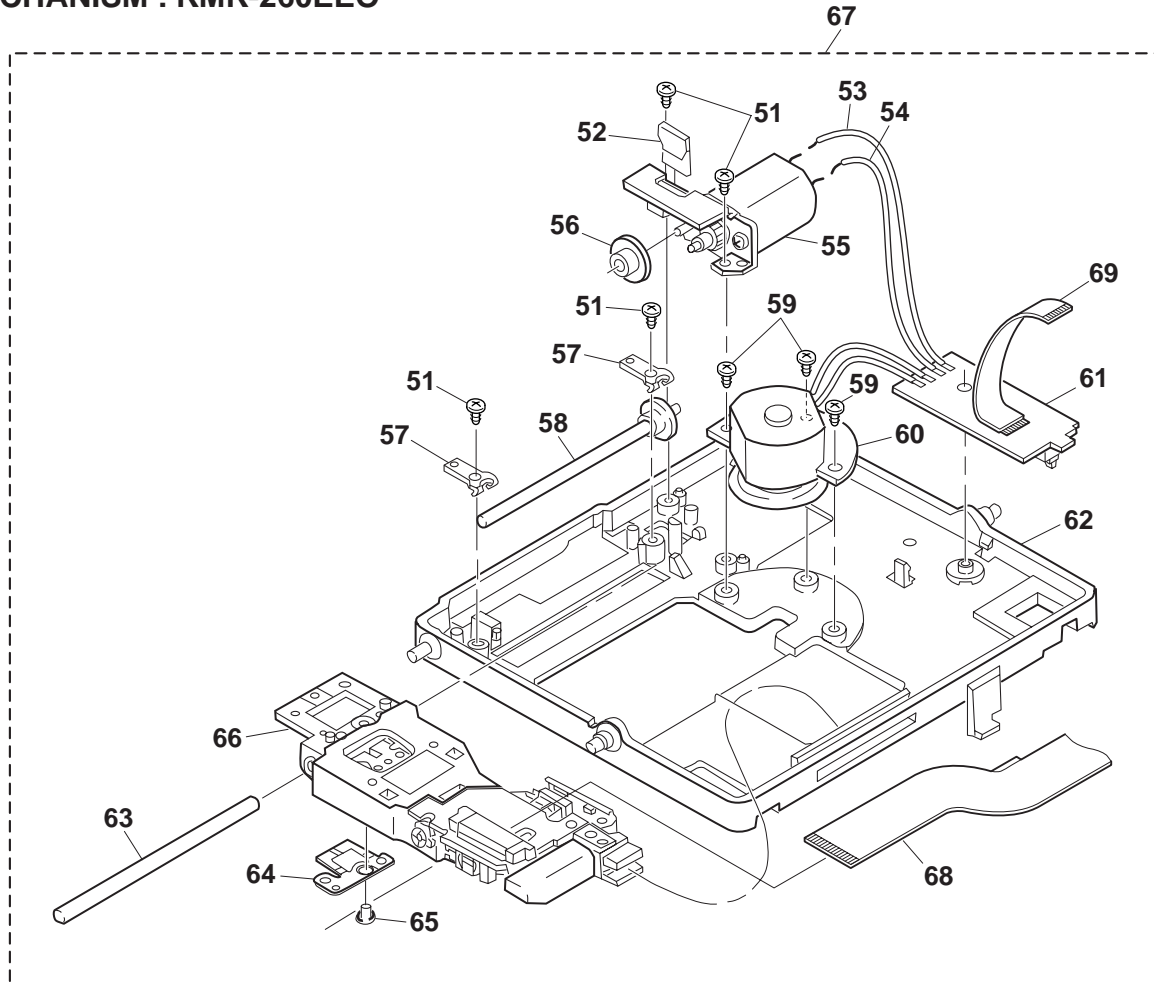

PARTS LIST

The mechanical parts with no part number in the exploded views are not supplied.

REF NO.	PART NO.	DESCRIPTION
51	3348-998-51	Pan tapping screw (M1.4 x 3.5)
52	2167-550-01	Plate (M), Pre-load
53	---	Wire, SL motor lead
54	---	Wire, SL motor lead
55	X2162-145-1	Sled motor ass'y
56	2646-571-01	Gear (MD)
57	2167-551-01	Plate (M), main shaft fixed
58	X2162-144-1	Screw ass'y, lead
59	2646-358-11	Screw (B1.7 x 4)
60	X2162-143-1	Spindle motor ass'y
61	---	D-SW Mount 2
62	---	Chassis (M), mechanical
63	2167-819-01	Shaft (M), guide
64	2647-338-01	Spring, rack
65	2627-529-01	Grip (1.7 x 2.5 type2)
66	8-583-079-06	Optical pickup, KMS-260E
67	---	Deck ass'y, mechanical
68	1669-180-11	OP Flexible flat cable
69	1783-387-11	Flexible flat cable (7core)

EXPLODED VIEW OF MECHANISM (MD) -3

MD MECHANISM : KMK-260EEO

MD mount view

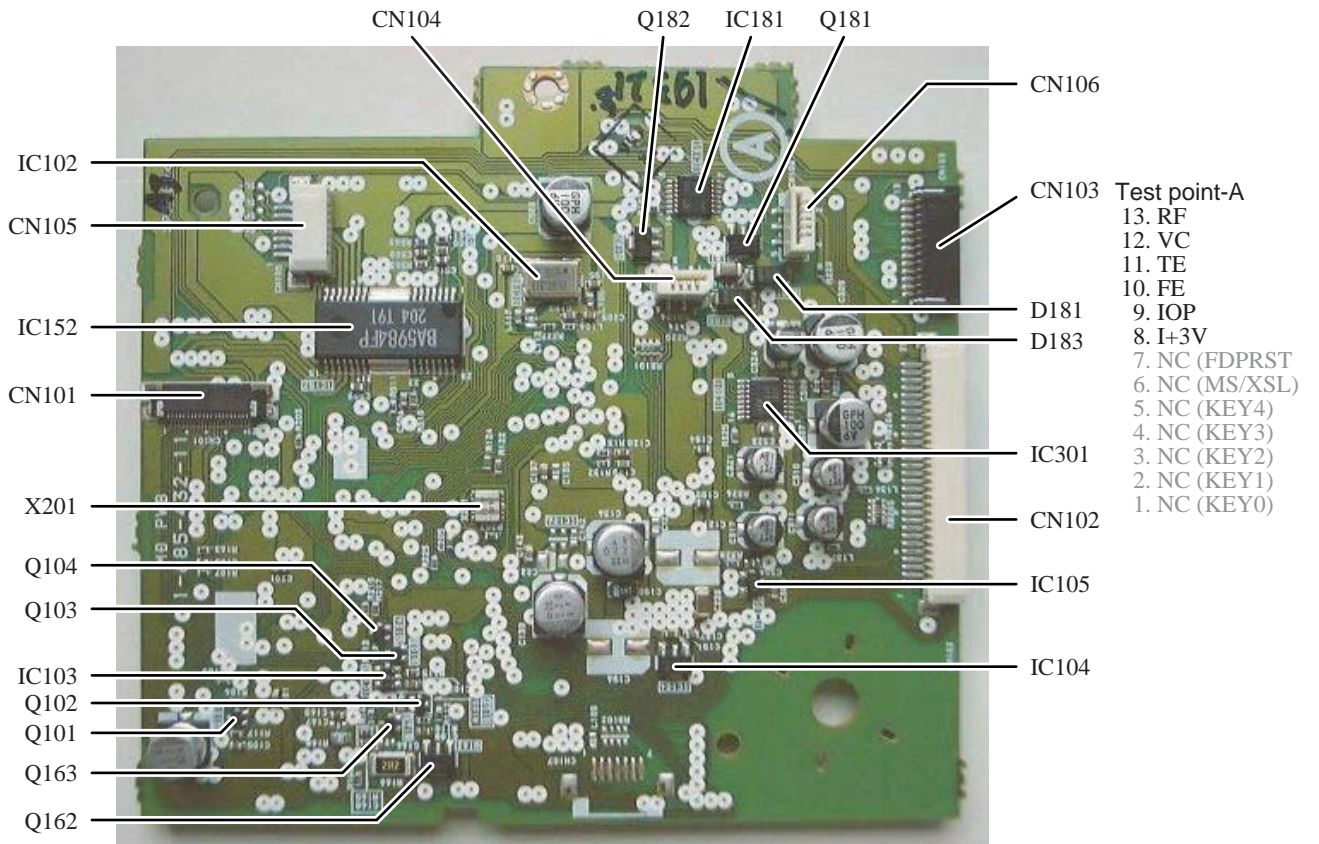

-- Side-A --

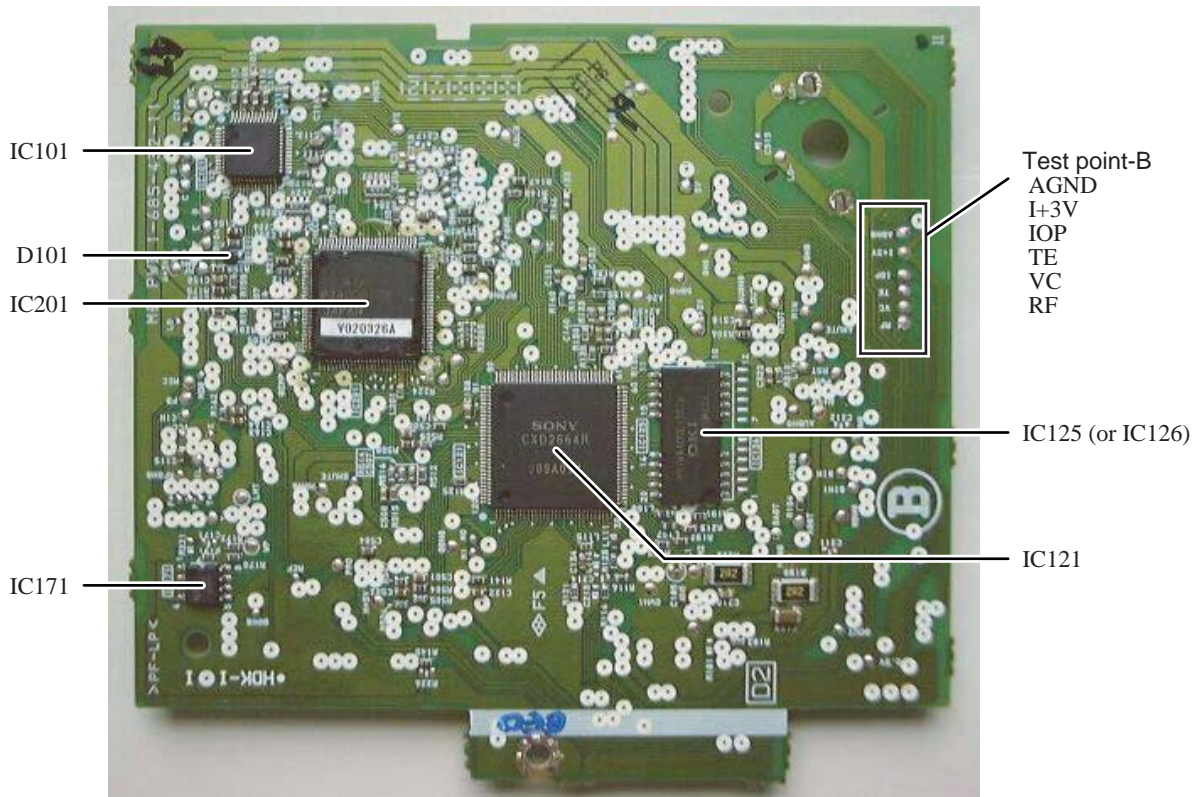

-- Side-B --

EXPLODED VIEW OF MECHANISM (MD) -4

MD MECHANISM : KMK-260EEO

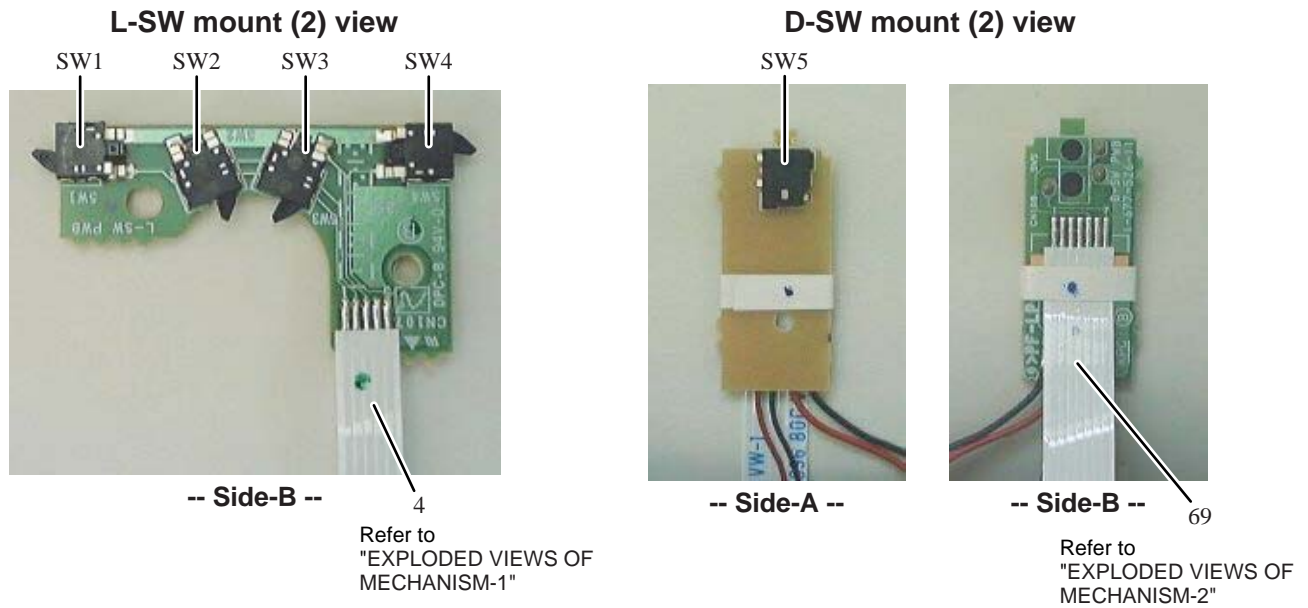

PARTS LIST (MD mount section)

The mechanical parts with no part number
in the exploded views are not supplied.

CIRCUIT NO.	PART NO.	DESCRIPTION
IC101	8752-080-95	CXA2523AR, IC
IC102	1781-569-21	90M, Crystal oscillator
IC103	8729-903-10	FMW1-T-148, Transistor
IC104	6702-431-01	RH5RZ33CA-T1, IC
IC105	8759-832-31	TK71533ASCL, IC
IC121	8752-414-89	CXD2664R, IC
IC125	8759-671-27	MSM51V4400E-70TS-K, IC
IC152	8759-574-24	BA5984FP-E2, IC
IC171	8759-640-39	BR24C02F-WE2, IC
IC181	8759-523-35	TC74ACT02FT (EL), IC
IC201	8752-932-73	CXP740010-063R, IC
IC301	6700-563-01	AK4552VT-E2, IC
Q101	8729-028-91	DTA144EUA-T106, Transistor
Q102	8729-026-52	2SA1576A-T106-QR, Transistor
Q103	8729-028-96	DTC114EUA-T106, Transistor
Q104	8729-028-96	DTC114EUA-T106, Transistor
Q162	8729-101-07	2SB798-T1DK, Transistor
Q163	8729-028-91	DTA144EUA-T106, Transistor
Q181	8729-018-75	2SJ278MYTR, Transistor
Q182	8729-017-66	2SK1764KYTR, Transistor
D101	223269R2	1SS355, Diode
D181	8719-046-87	F1J6TP, Diode
D183	8719-046-87	F1J6TP, Diode
X201	1767-179-31	12M, Ceramic oscillator
CN101	1691-385-21	Connector, FFC/FPC (21P)
CN102	1778-461-11	Connector, FFC/FPC (29P)
CN103	1793-793-21	Connector, FFC/FPC (13P)
CN104	1778-283-11	Connector, FFC/FPC (4P)
CN105	1779-345-11	Connector, FFC/FPC (7P)
CN106	1779-353-21	Connector, FFC/FPC (5P)
SW1--SW4	1771-092-21	Push switch (1key)
SW5	1771-327-11	2pin push switch (2key)
---	---	L-SW mount 2, PC board
---	---	D-SW mount 2, PC board

SCHEMATIC DIAGRAMS-4 MD MECHANISM : KMK-260EEO

1
2
3
4
5

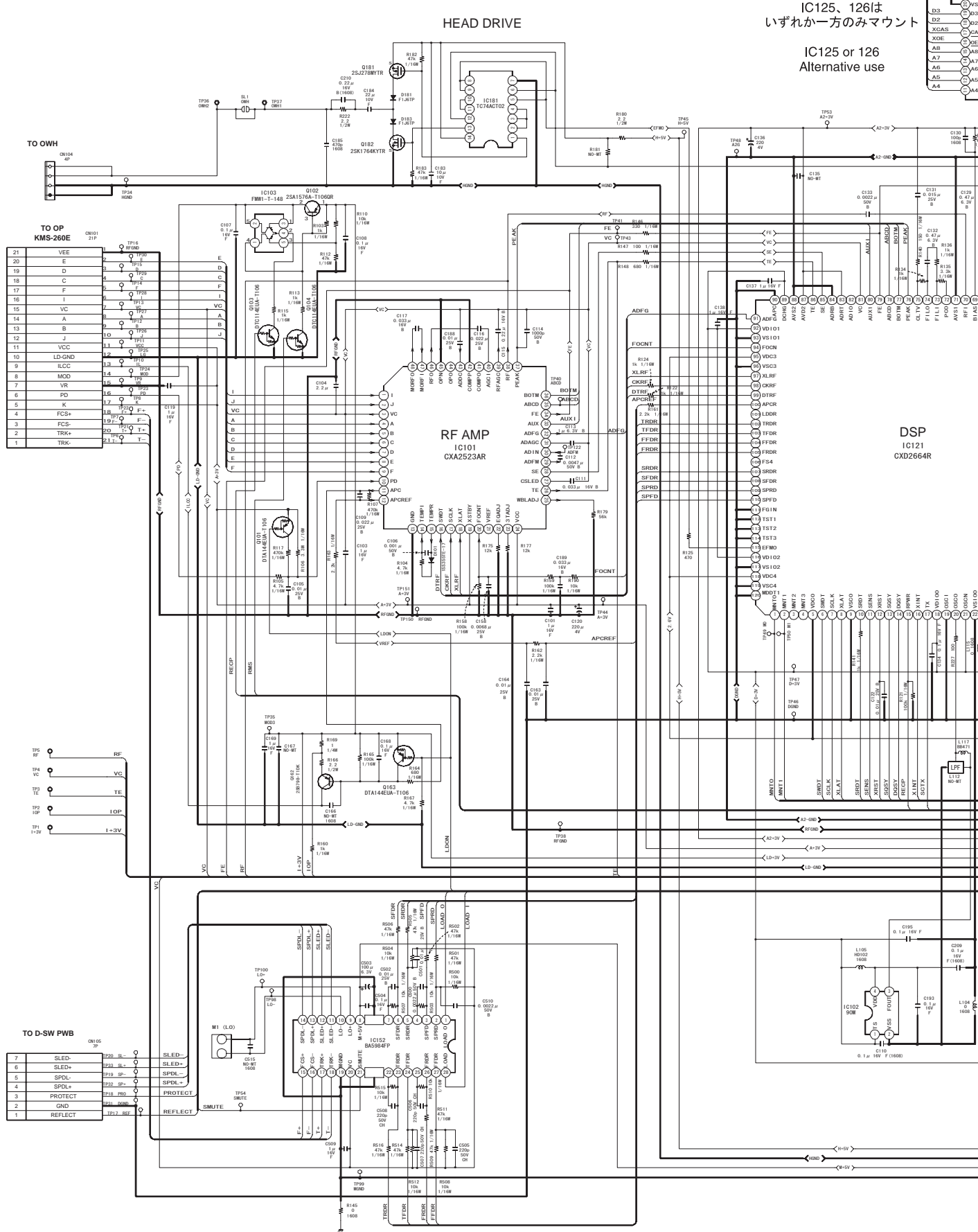

IC125, 126は
いずれか一方のみマウント
IC125 or 126
Alternative use

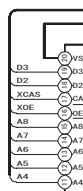

DSP
IC121
CXD2664R

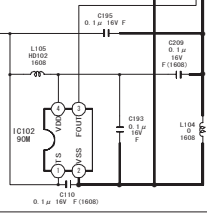

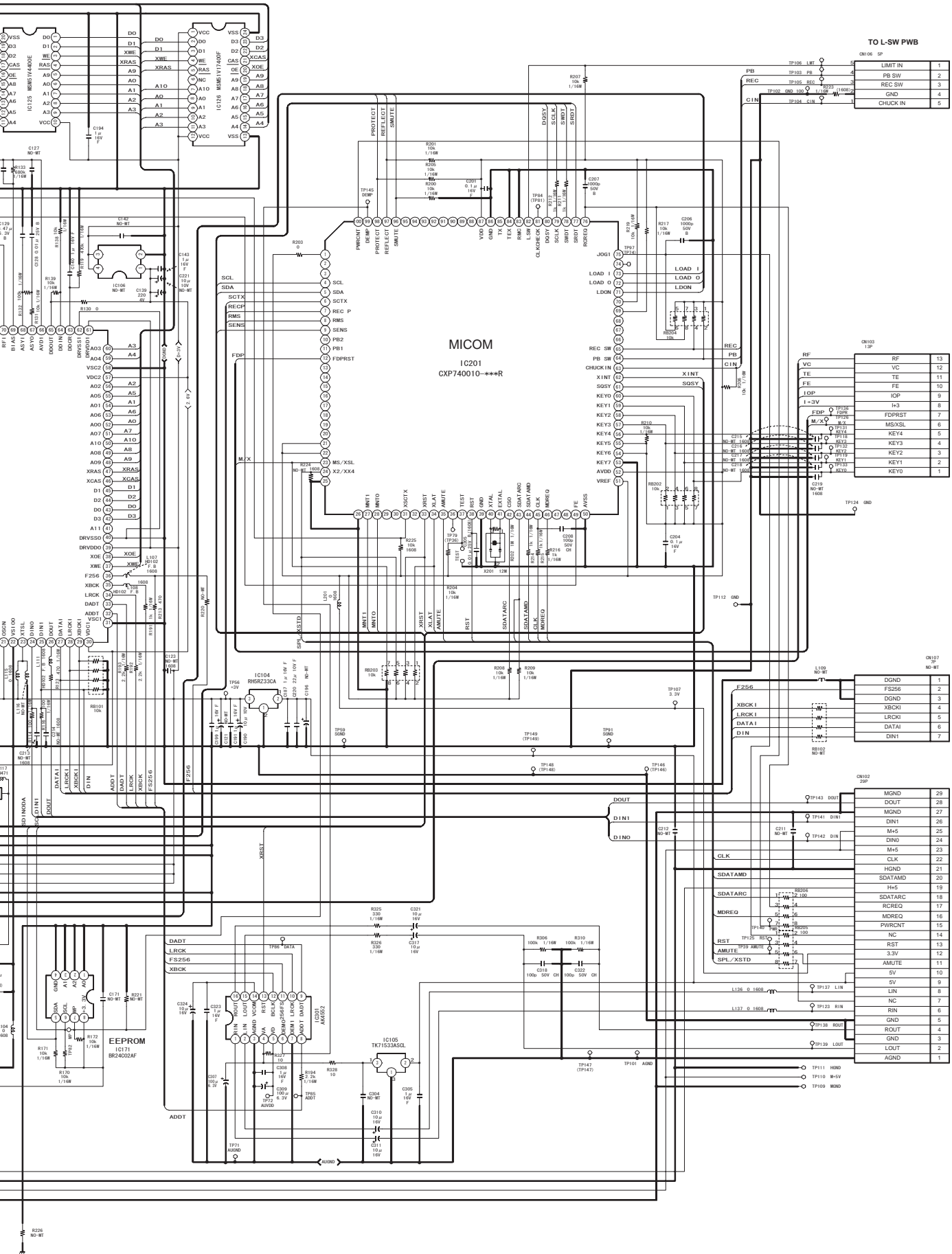

SCHEMATIC DIAGRAMS-3 DISPLAY SECTION

SCHEMATIC DIAGRAMS-2 NADG-7557(P801A)

1

2

3

4

5

NC: No connection

NASW-7587 U3 OPERATION SWITCH PC BOARD

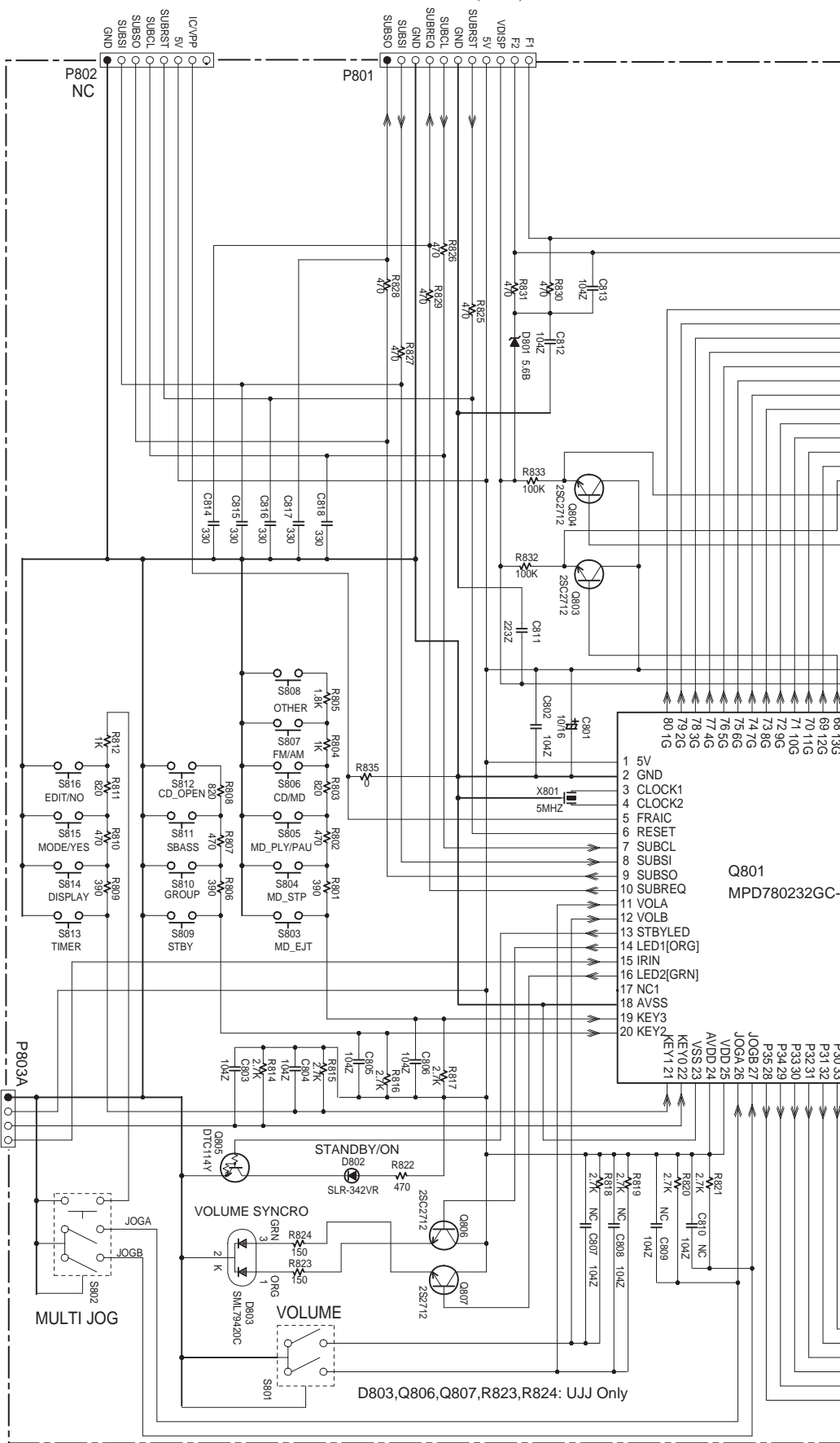
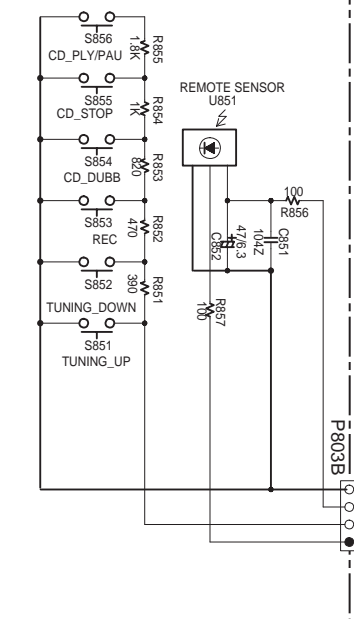

D803,Q806,Q807,R823,R824: UJJ Only

E





F

G

H

NADIS-7586
U2 DISPLAY PC BOARD

NOTE

- THE COMPONENTS IDENTIFIED BY MARK  ARE CRITICAL FOR SAFETY. REPLACE ONLY WITH PART NUMBER SPECIFIED.
- VOLTAGE(MEASURED WITH VOLTMETER)  IS DC VOLTAGE. (NO INPUT SIGNAL)
- ELECTROLYTIC CAPACITORS () ARE IN uF/WV.
- ALL CAPACITORS ARE IN pF/50WV UNLESS OTHERWISE NOTED.
 EX) 030 → 3pF 330 → 33pF 331 → 330pF 333 → 0.033uF
- ALL RESISTORS ARE IN OHMS 1/4WATTS UNLESS OTHERWISE NOTED.
- THE THICK LINES ON PC BOARD ARE THE PRINTING SIDE OF THE PARTS.
 EX)  PRINTING SIDE
- CIRCUIT IS SUBJECT TO CHANGE FOR IMPROVEMENT.

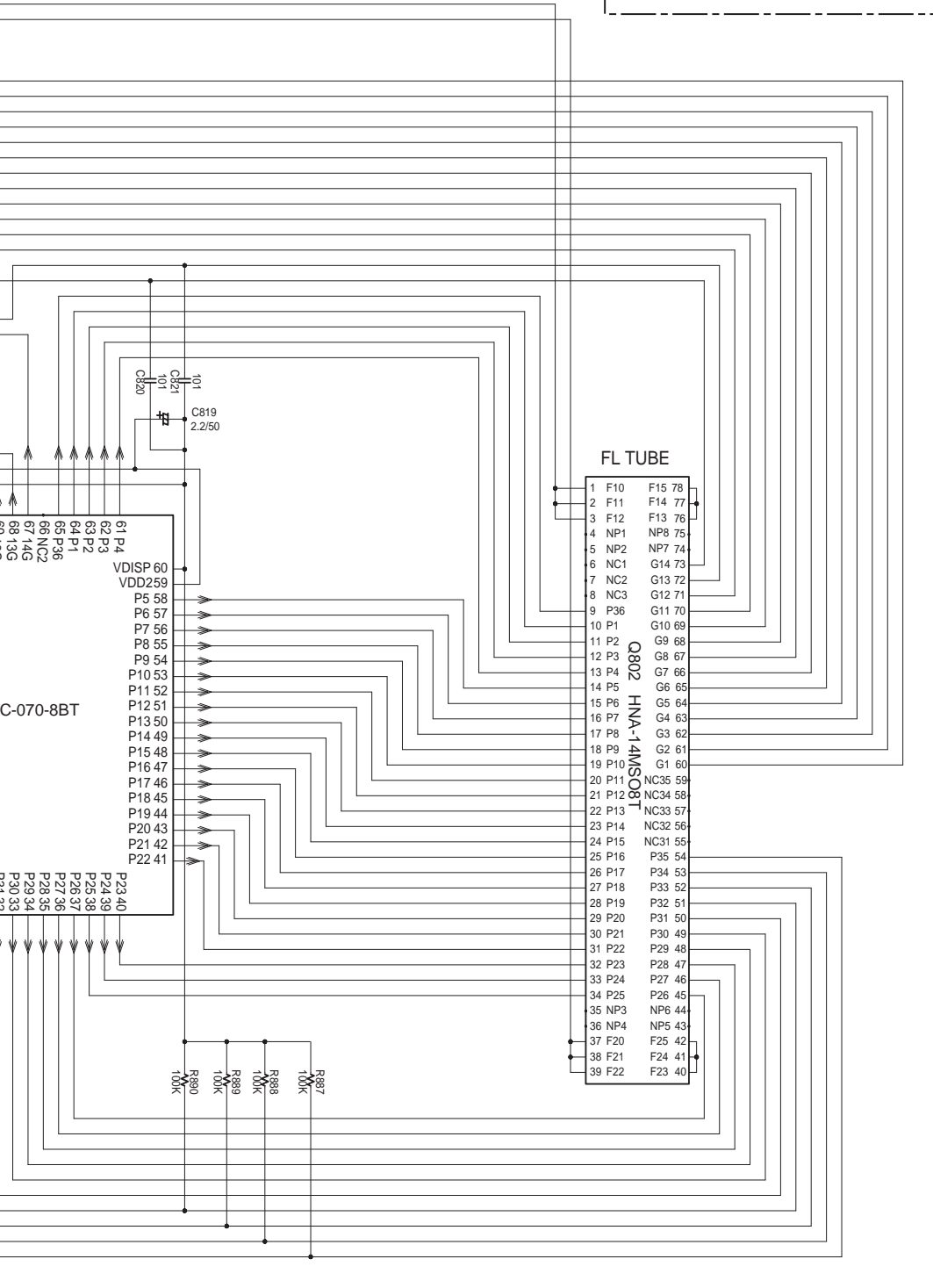

SCHEMATIC DIAGRAMS-2 CD AND MICROPROCESSOR SECTION

NADG-7557 U9 CD and MICROPROCESSOR PC BOARD

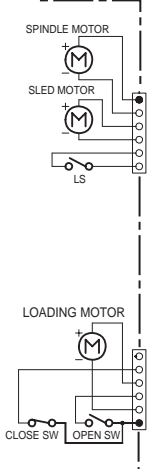
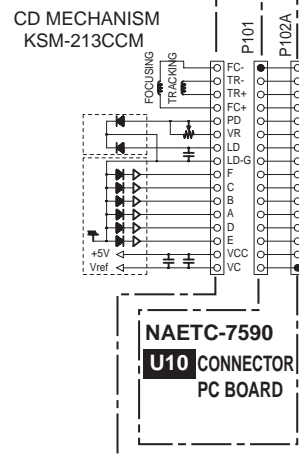

SCHEMATIC DIAGRAMS-1
To NAPS-7553(JL352A)

SCHEMATIC DIAGRAMS-1
To NAPS-7553(JL703A)

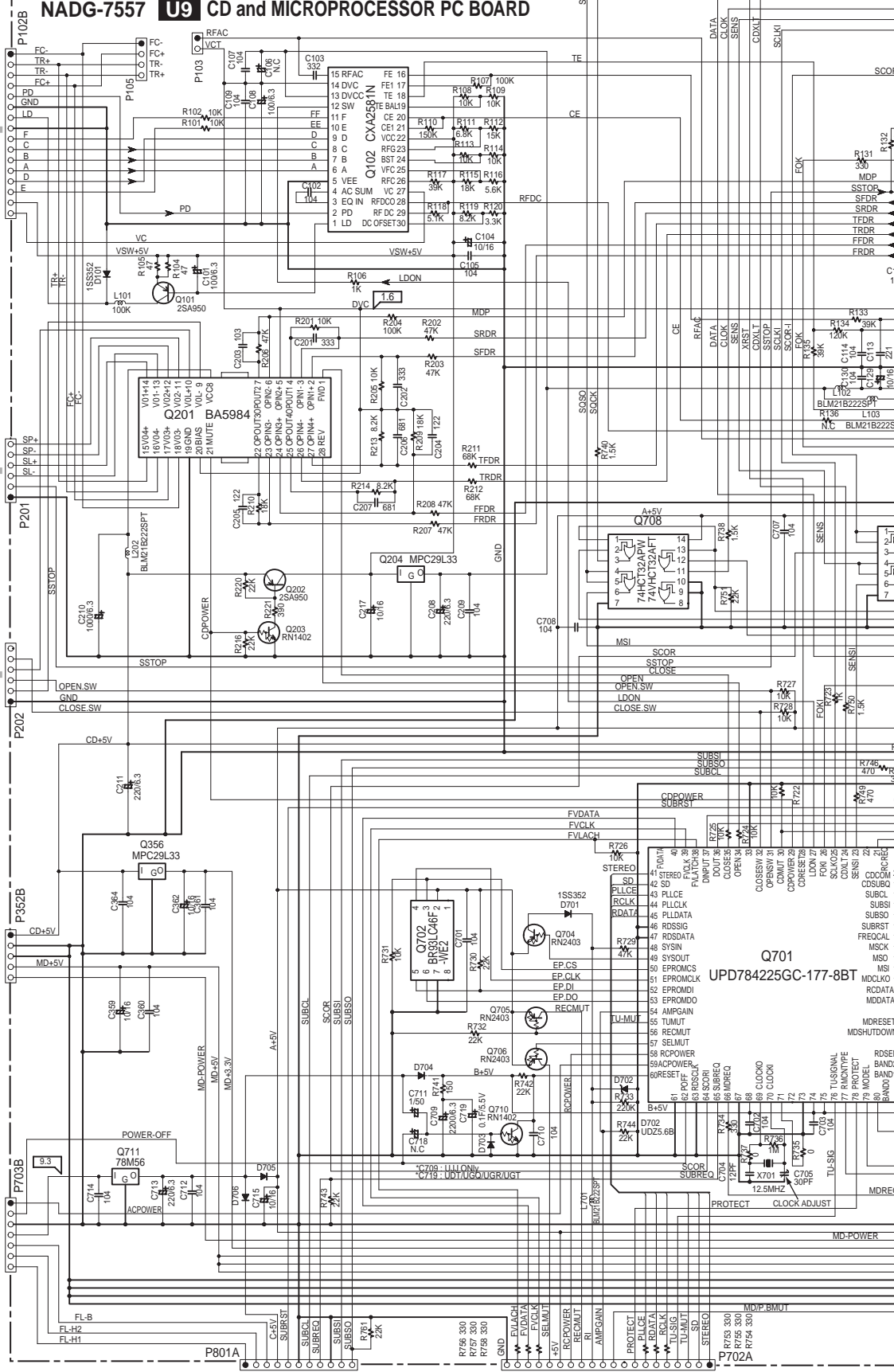

To NADIS-7586(P801)
SCHEMATIC DIAGRAMS-3

To NAAF-7585(P702B)
SCHEMATIC DIAGRAMS-1

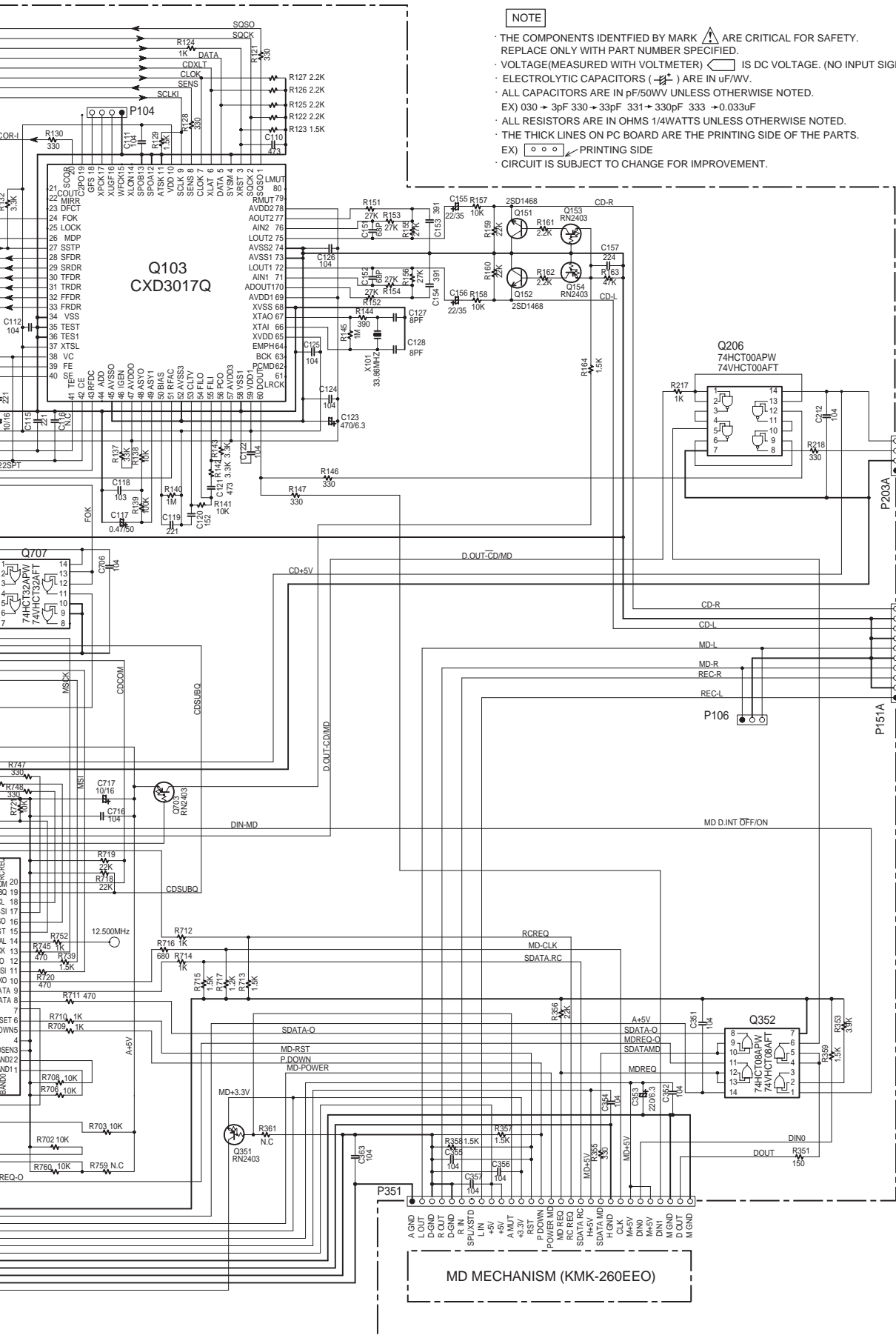

NOTE

- THE COMPONENTS IDENTIFIED BY MARK ARE CRITICAL FOR SAFETY. REPLACE ONLY WITH PART NUMBER SPECIFIED.
- VOLTAGE (MEASURED WITH VOLTMETER) IS DC VOLTAGE. (NO INPUT SIGNAL)
- ELECTROLYTIC CAPACITORS () ARE IN uF/5V.
- ALL CAPACITORS ARE IN pF/50V UNLESS OTHERWISE NOTED.
EX) 030 → 3pF 330 → 33pF 331 → 330pF 333 → 0.033uF
- ALL RESISTORS ARE IN OHMS 1/4WATTS UNLESS OTHERWISE NOTED.
- THE THICK LINES ON PC BOARD ARE THE PRINTING SIDE OF THE PARTS.
EX) PRINTING SIDE
- CIRCUIT IS SUBJECT TO CHANGE FOR IMPROVEMENT.

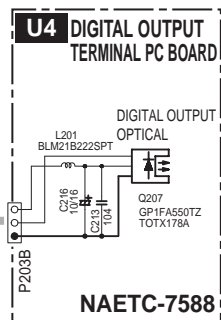

SCHMATIC DIAGRAMS-1
To NAAF-7585(P151B)

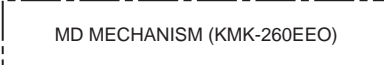

SCHEMATIC DIAGRAMS-1 AMPLIFIER SECTION

U1 PREAMPLIFIER PC BOARD NAAF-7585

R437,R438	NC
UJJ	NEED
UDT	NEED
UGT,UGR,UGQ	NEED

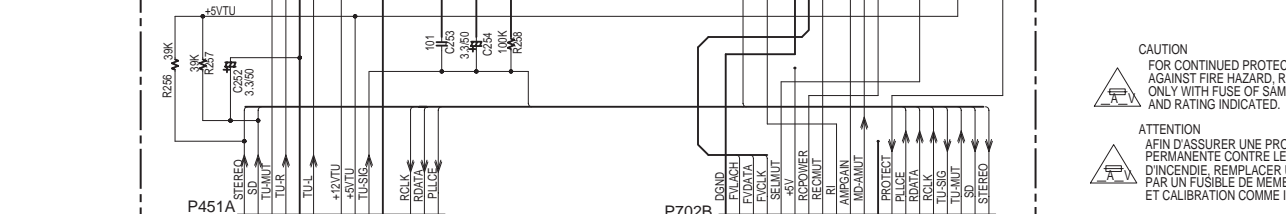
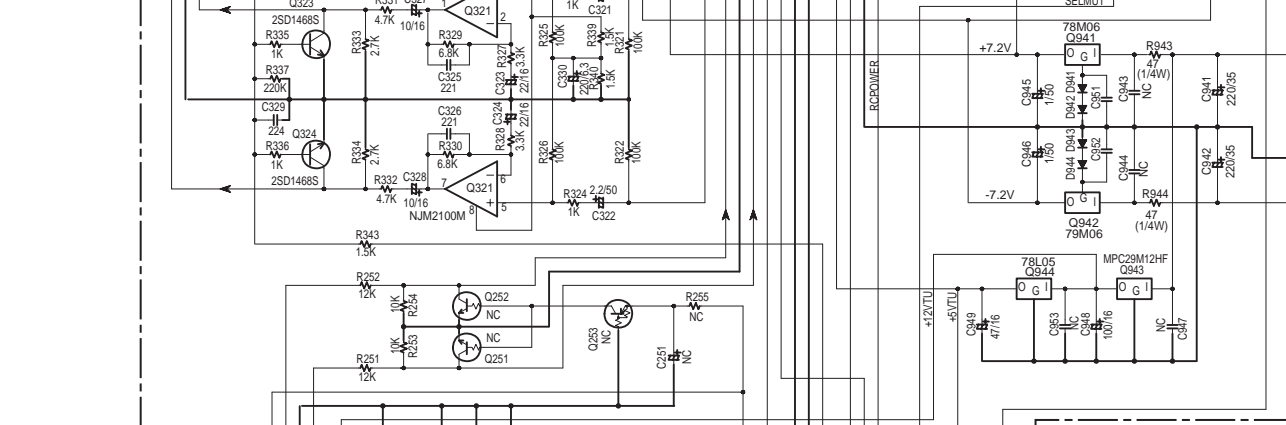
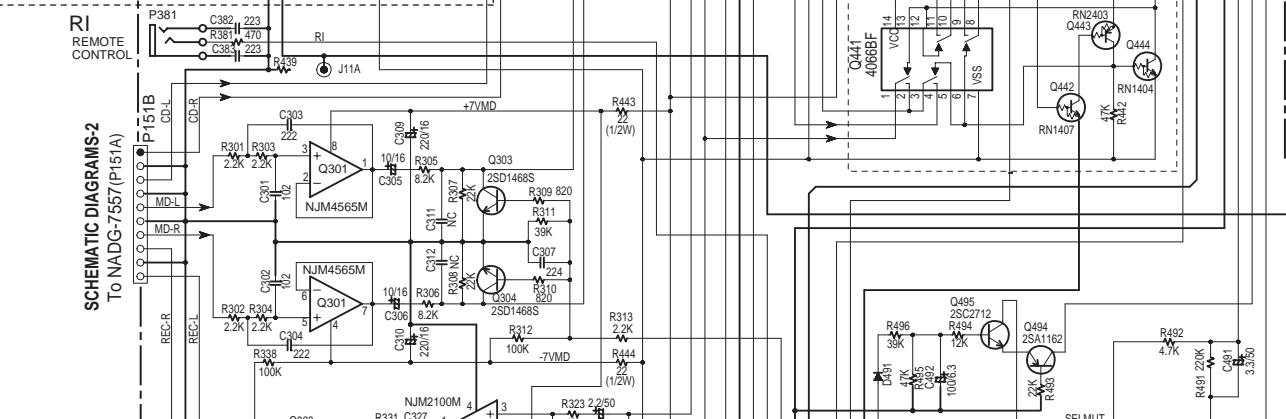
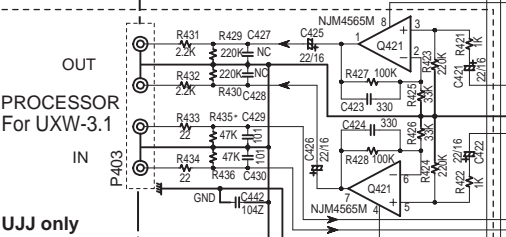
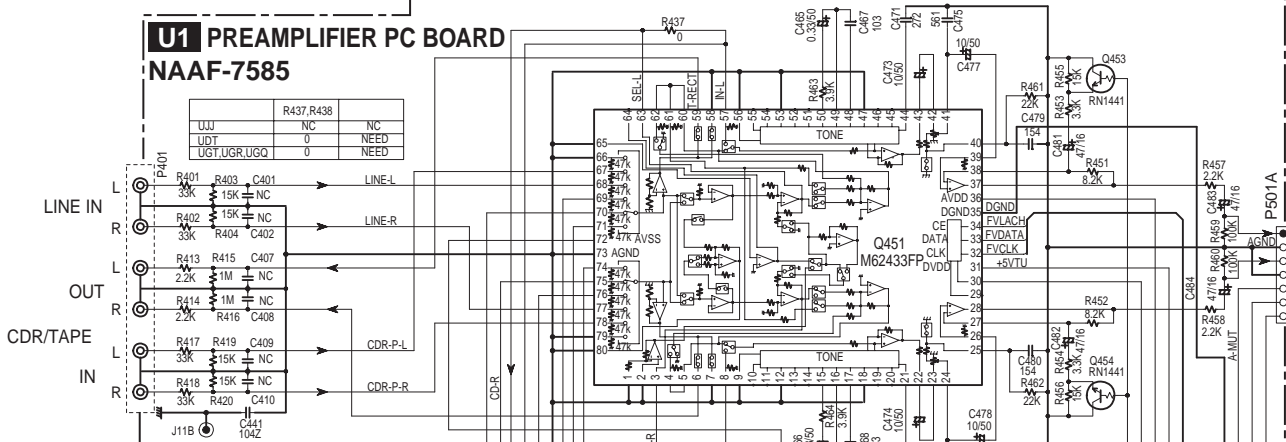

U7 POWER PC BOARD NAAF-7585

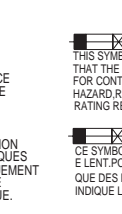
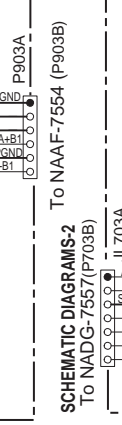
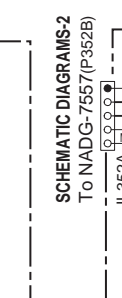
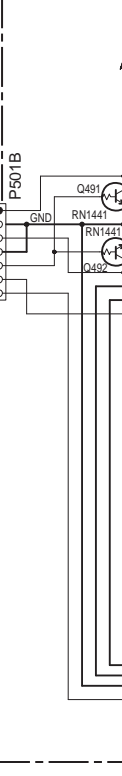

To TUNER UNIT

SCHEMATIC DIAGRAMS-2
To NADG-7557(P702B)

SCHEMATIC DIAGRAMS-2
To NADG-7557(P362B)

SCHEMATIC DIAGRAMS-2
To NADG-7557(P703B)

SCHEMATIC DIAGRAMS-2
To NAAF-7554 (P903B)

CAUTION
FOR CONTINUED PROTECTION
AGAINST FIRE HAZARD, REPLACE
ONLY WITH FUSE OF SAME TYPE
AND RATING INDICATED.

ATTENTION
AFIN D'ASSURER UNE PROTECTION
PERMANENTE CONTRE LES RISQUES
D'INCENDIE, REMPLACER UNIQUEMENT
PAR UN FUSIBLE DE MEME TYPE
ET CALIBRATION COMME INDIQUE.

THIS SYMBOL
THAT THE FL
FOR CONTIN
HAZARD REF
RATING REF

CE SYMBOL
LENT POU
INDIQUE LA

E

F

G

H

AMPLIFIER BOARD 554

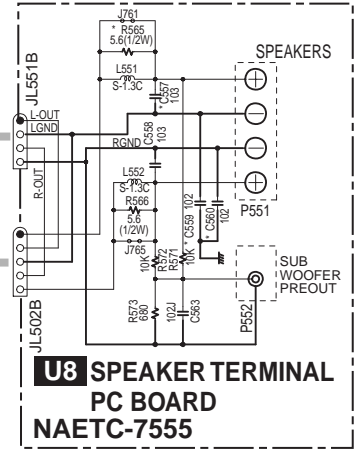
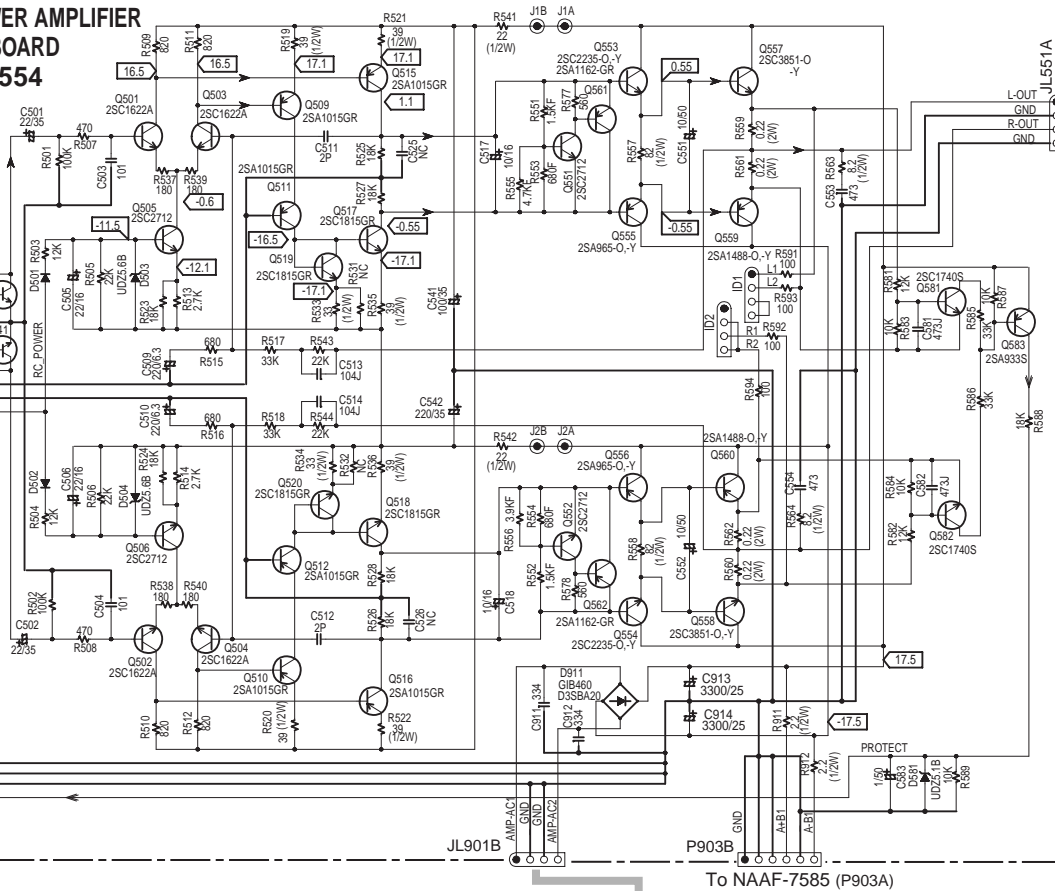

U8 SPEAKER TERMINAL PC BOARD NAETC-7555

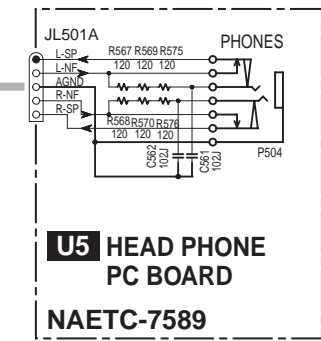

U5 HEAD PHONE PC BOARD NAETC-7589

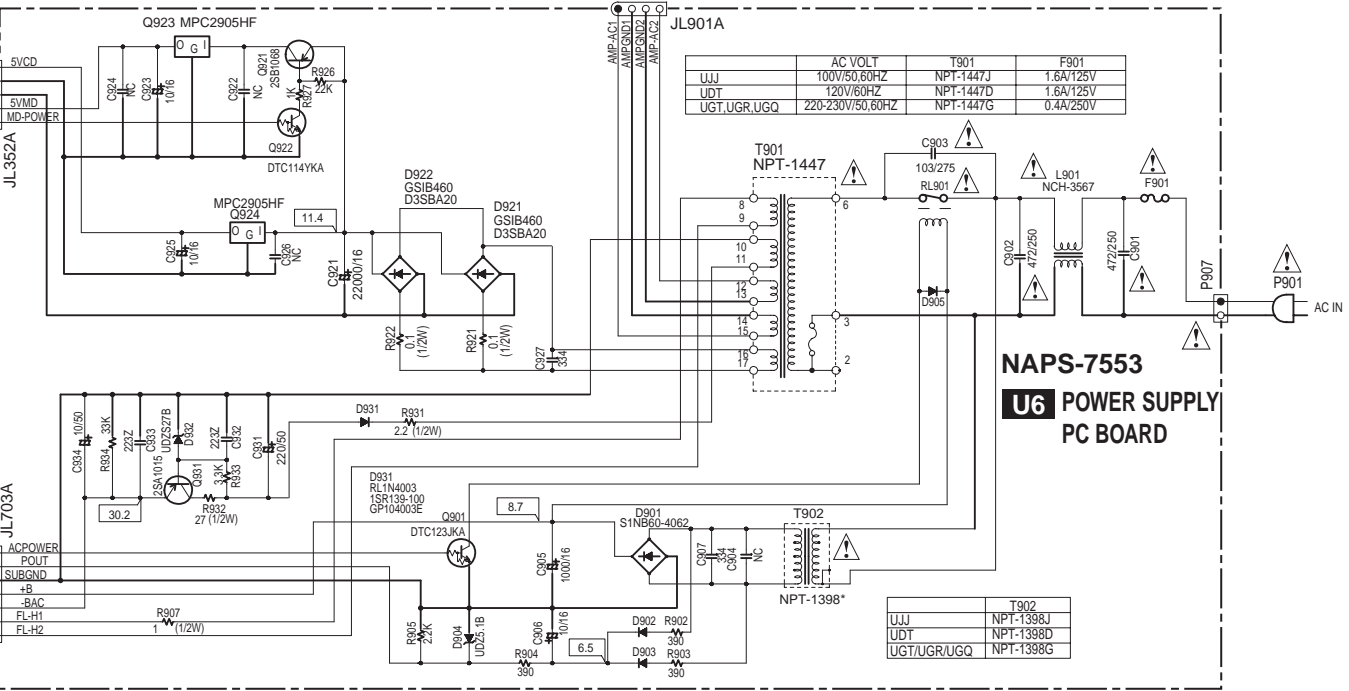

NAPS-7553 U6 POWER SUPPLY PC BOARD

	AC VOLT	T901	F901
UJJ	100V/50.60HZ	NPT-1447J	1.6A/125V
UDT	120V/60HZ	NPT-1447D	1.6A/125V
UGT,UGR,UGQ	220-230V/50.60HZ	NPT-1447G	0.4A/250V

	T902
UJJ	NPT-1398J
UDT	NPT-1398D
UGT/UGR/UGQ	NPT-1398G

NOTE

- THE COMPONENTS IDENTIFIED BY MARK ARE CRITICAL FOR SAFETY. REPLACE ONLY WITH PART NUMBER SPECIFIED.
- VOLTAGE (MEASURED WITH VOLTMETER) IS DC VOLTAGE. (NO INPUT SIGNAL)
- ELECTROLYTIC CAPACITORS () ARE IN uF/WV.
- ALL CAPACITORS ARE IN pF/50VV UNLESS OTHERWISE NOTED.
- EX) 030 → 3pF 330 → 33pF 331 → 330pF 333 → 0.033uF
- ALL RESISTORS ARE IN OHMS 1/4WATTS UNLESS OTHERWISE NOTED.
- THE THICK LINES ON PC BOARD ARE THE PRINTING SIDE OF THE PARTS.
- EX) PRINTING SIDE
- CIRCUIT IS SUBJECT TO CHANGE FOR IMPROVEMENT.

[NOTE]

- UJJ : Japanese model only
- UDT : Taiwanese model only
- UGT : Some Asian model only
- UGR : Chinese model only
- UGQ : Hong kong model only

SYMBOL LOCATED NEAR THE FUSE INDICATES FUSE USED IS SLOW OPERATING TYPE WITHINUED PROTECTION AGAINST FIRE
 REPLACE WITH SAME TYPE FUSE FOR FUSE REFER TO THE MARKING ADJACENT TO THE SYMBOL.
 SOLE INDIQUE QUE LE FUSIBLE UTILISE EST POUR UNE PROTECTION PERMANENTE.N'UTILISER S FUSIBLES DE MEME TYPE. CE DERNIER EST LA QU LE PRESENT SYMBOL EST APPOSE.

PC BOARD CONNECTION DIAGRAM

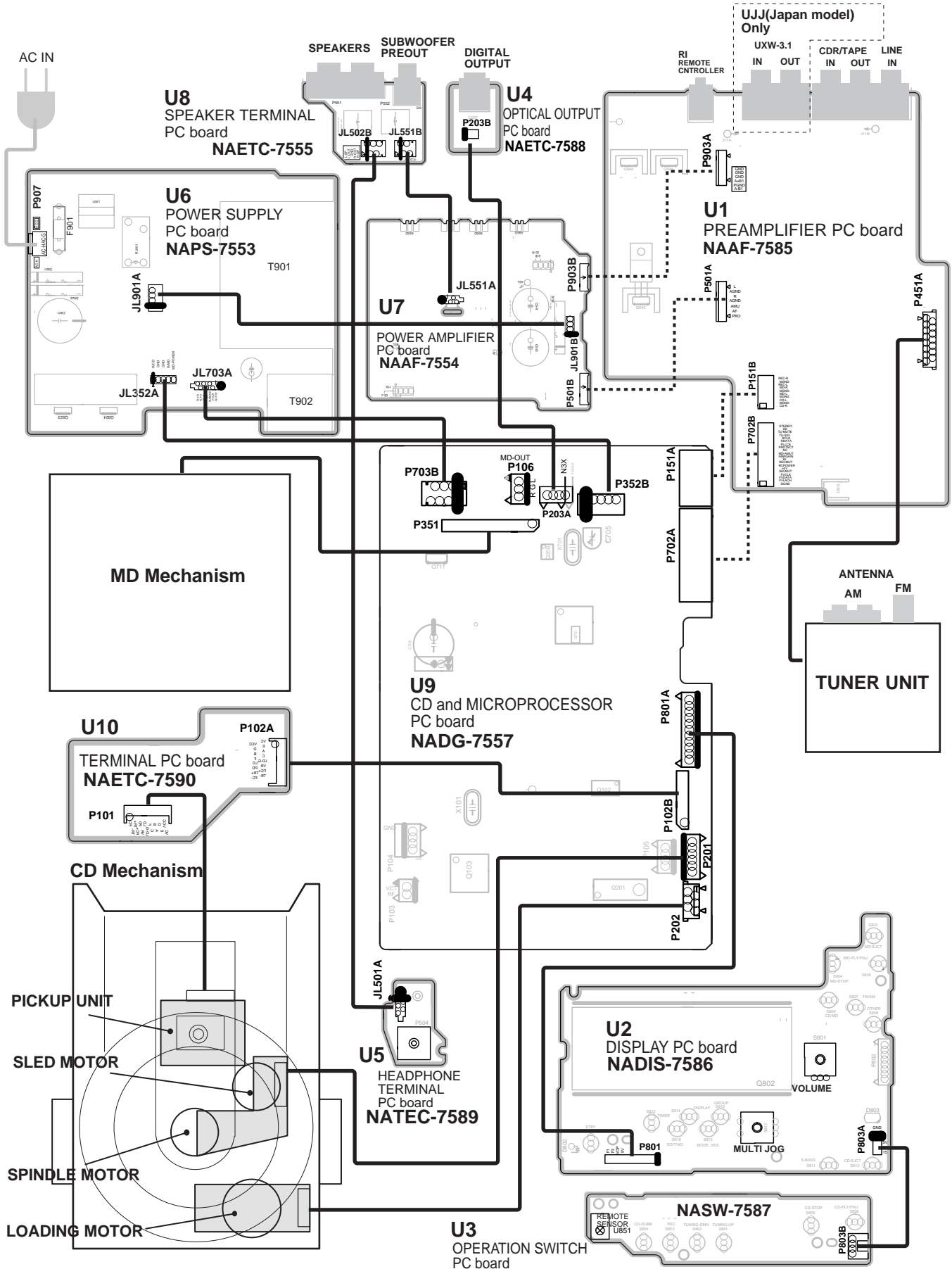

A

B

C

D

PRINTED CIRCUIT BOARD VIEWS-9

U2 DISPLAY PC BOARD (NADIS-7586)

1

2

3

4

5

Component side

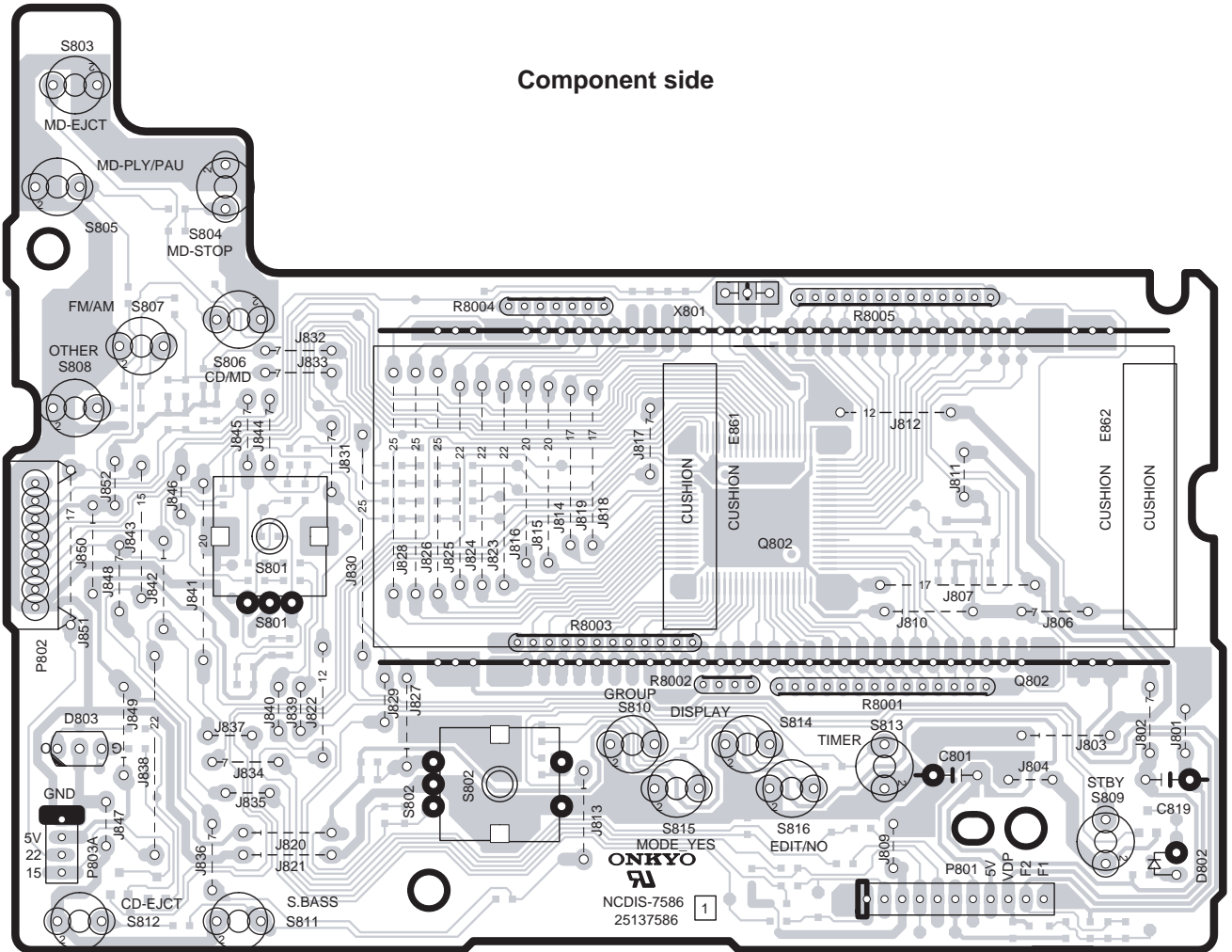

A

B

C

D

PRINTED CIRCUIT BOARD VIEWS-7

U9 CD and MICROPROCESSOR PC BOARD (NADG-7557)

1

Bottom side view

2

3

4

5

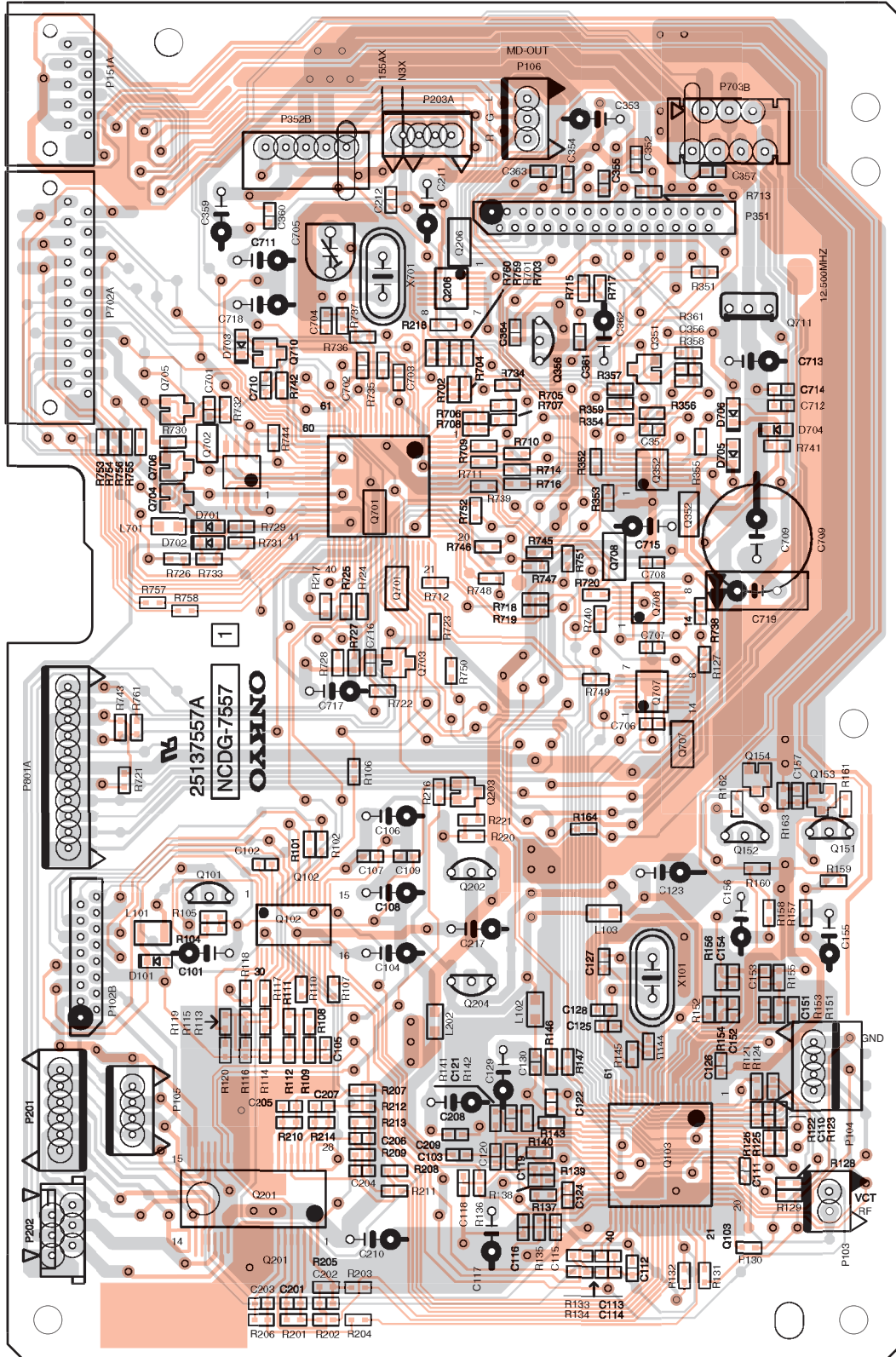

PRINTED CIRCUIT BOARD VIEWS-6

U9 CD and MICROPROCESSOR PC BOARD (NADG-7557)

1

Top side view

2

3

4

5

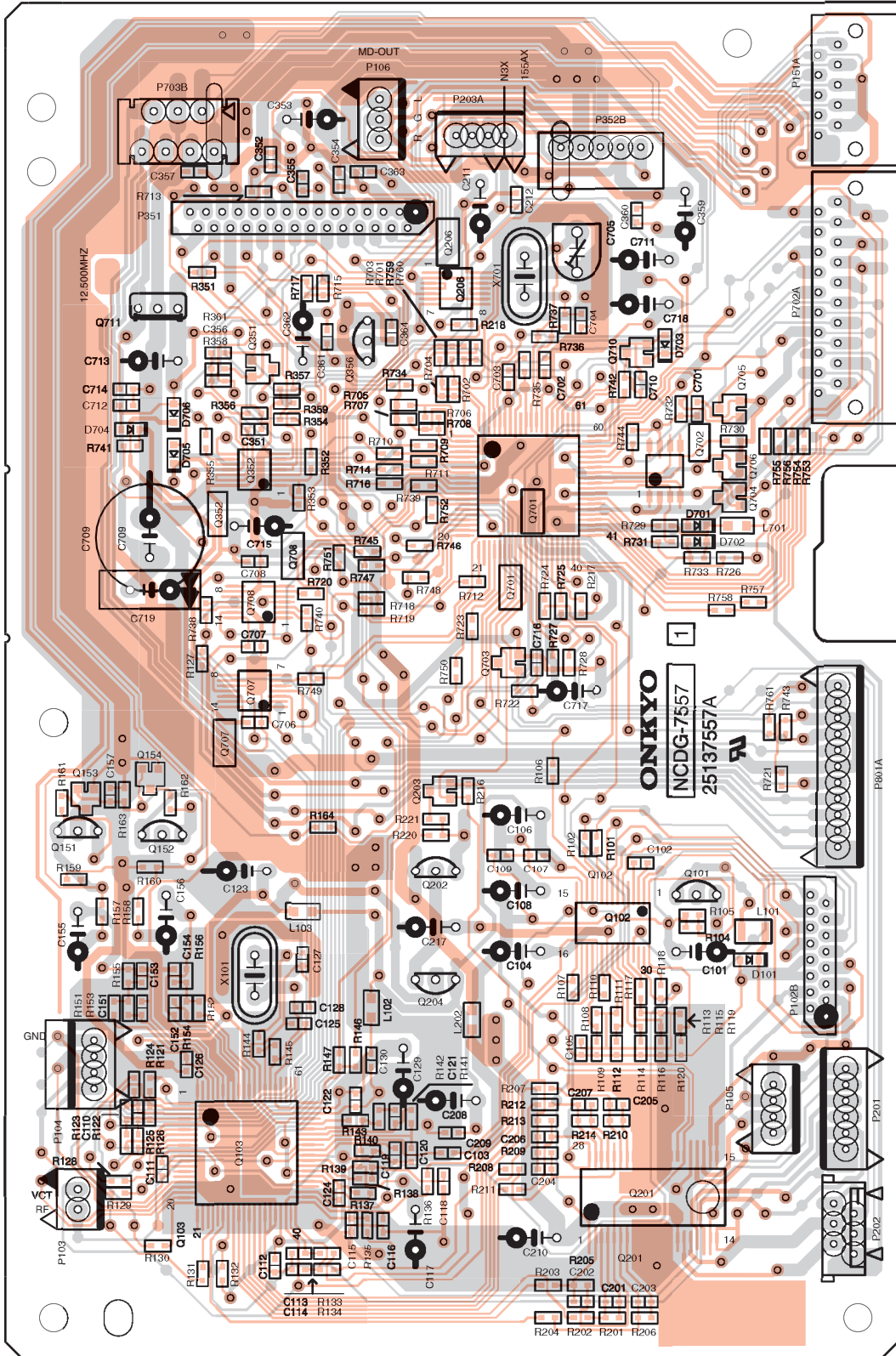

A

B

C

D

PRINTED CIRCUIT BOARD VIEWS-5

1

U5 HEAD PHONE PC BOARD (NAETC-7589)

Component side

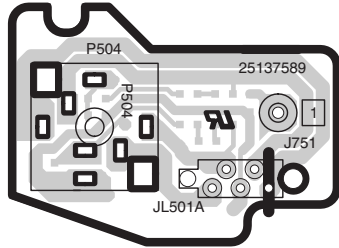

Soldering side

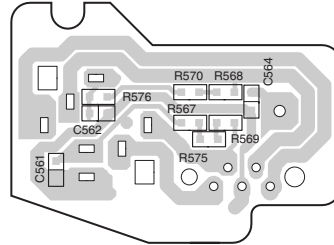

2

3

U8 SPEAKER TERMINAL PC BOARD (NAETC-7555)

Component side

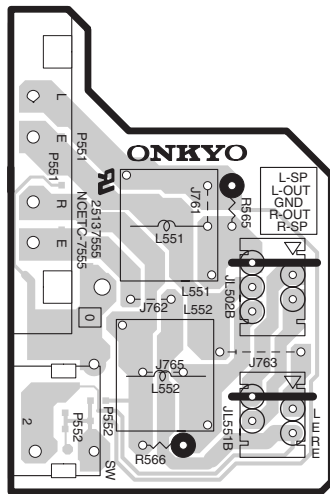

Soldering side

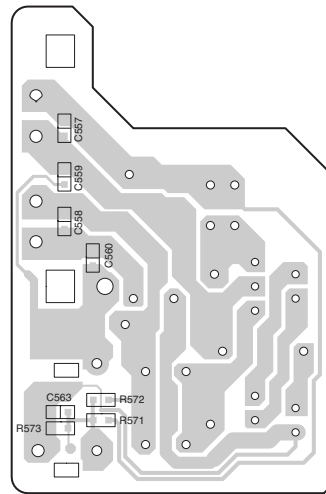

4

5

A

B

C

D

PRINTED CIRCUIT BOARD VIEWS-4

U7 POWER AMPLIFIER PC BOARD (NAAF-7554)

1

Soldering side

2

3

4

5

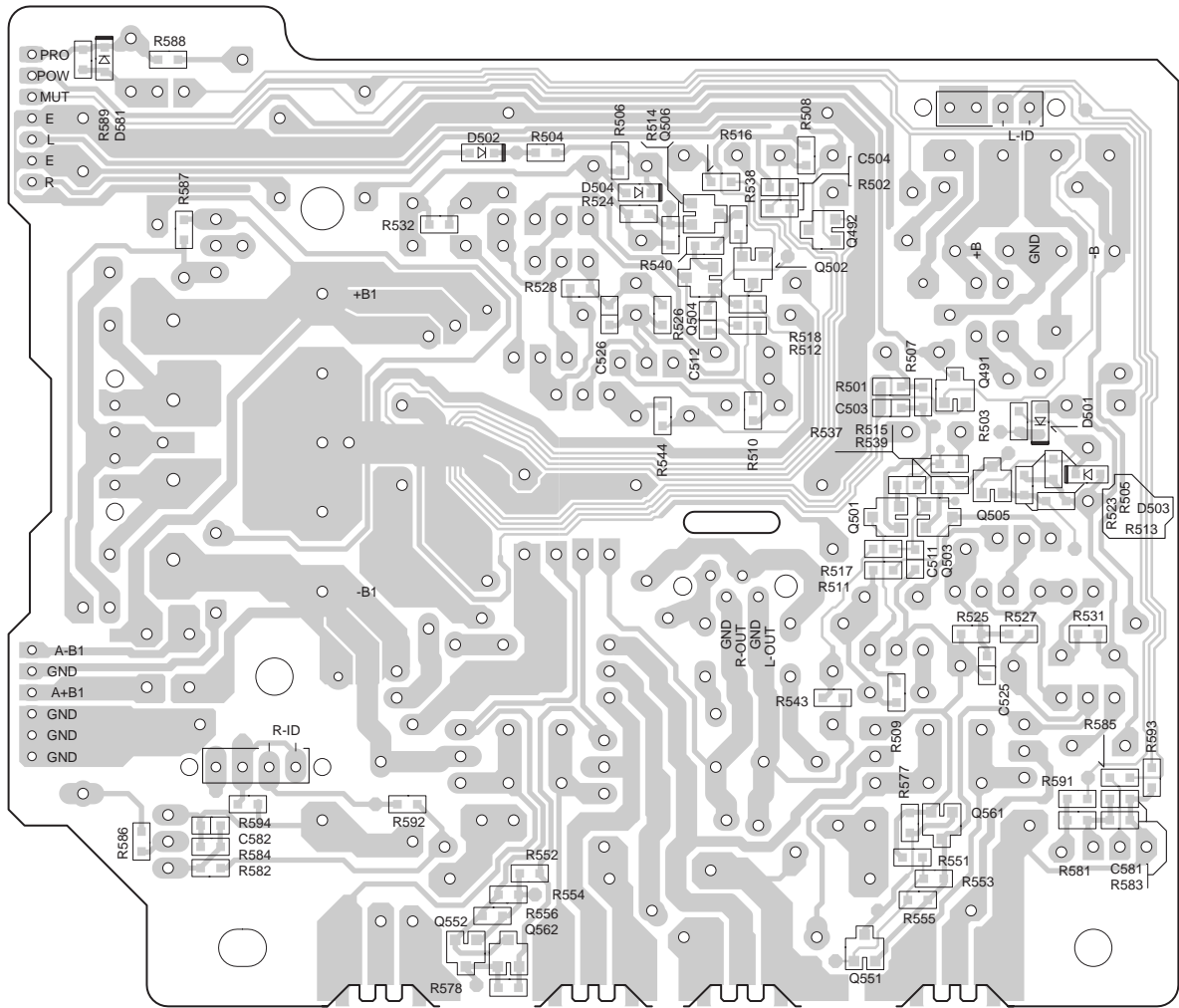

A

B

C

D

PRINTED CIRCUIT BOARD VIEWS-3

U7 POWER AMPLIFIER PC BOARD (NAAF-7554)

Component side

1

2

3

4

5

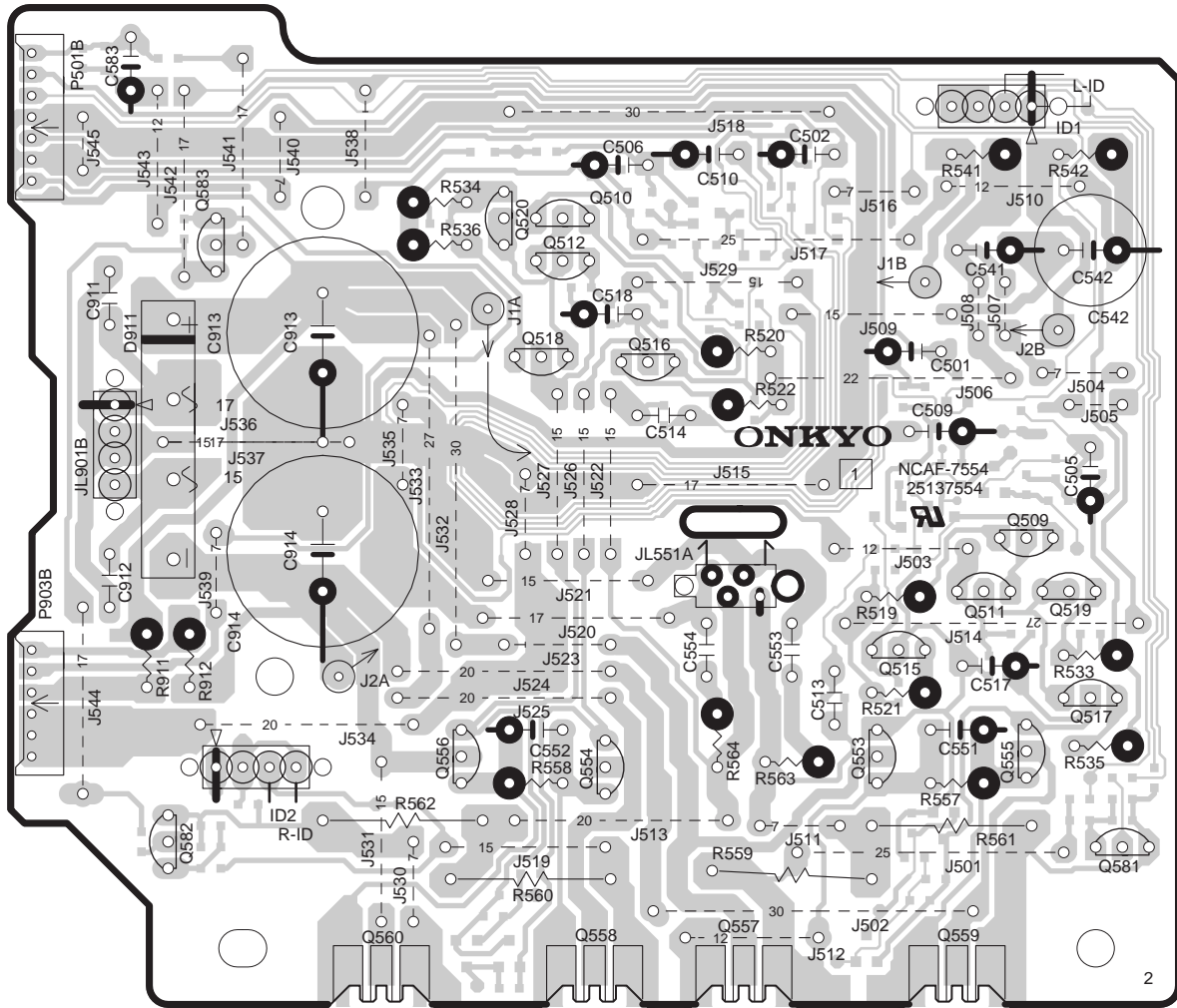

A

B

C

D

PRINTED CIRCUIT BOARD VIEWS-2

U1 PREAMPLIFIER PC BOARD (NAAF-7585)

1

Soldering side

2

3

4

5

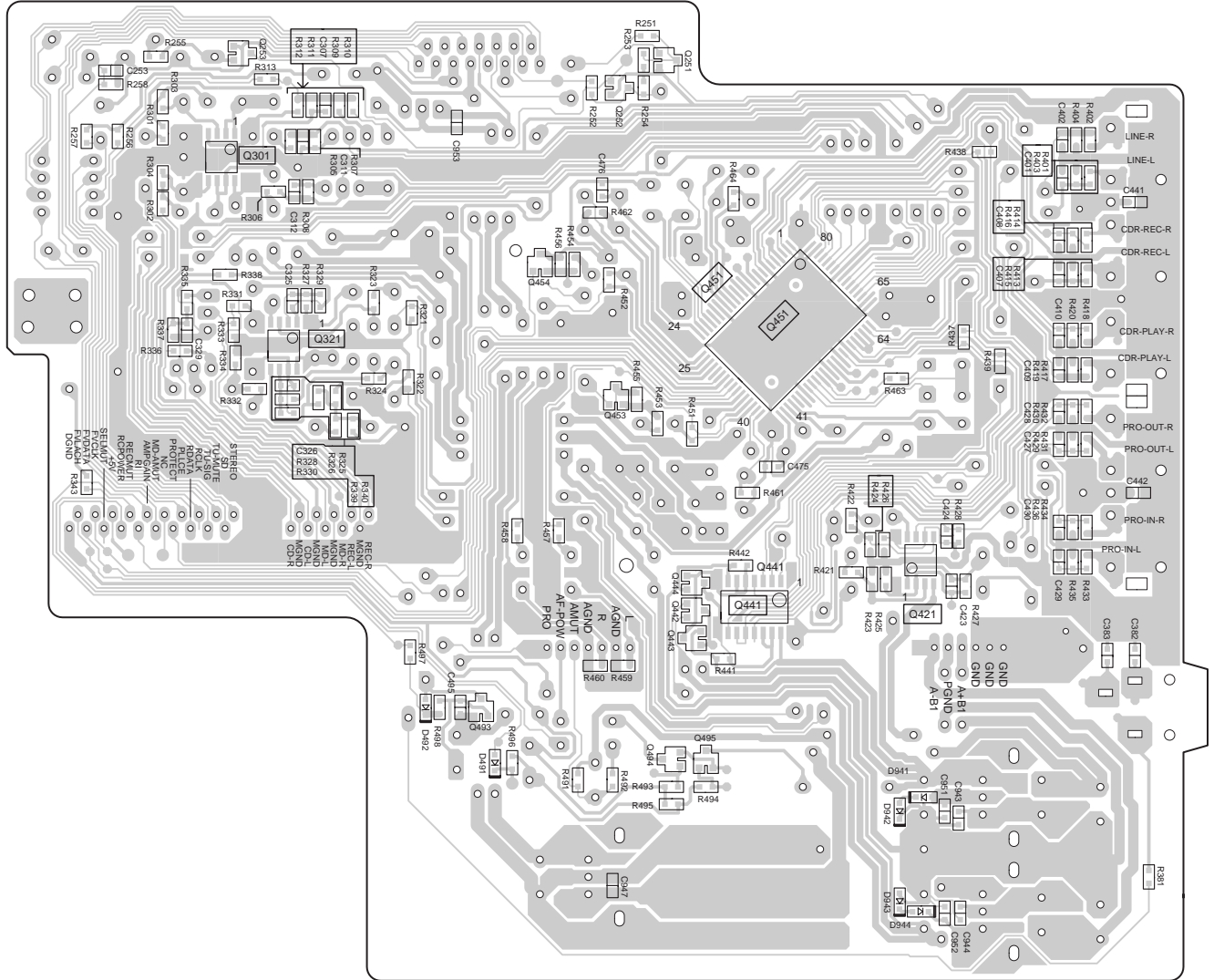

A

B

C

D

PRINTED CIRCUIT BOARD VIEWS-13

U3 OPERATION SWITCH PC BOARD (NASW-7587)

1

Soldering side

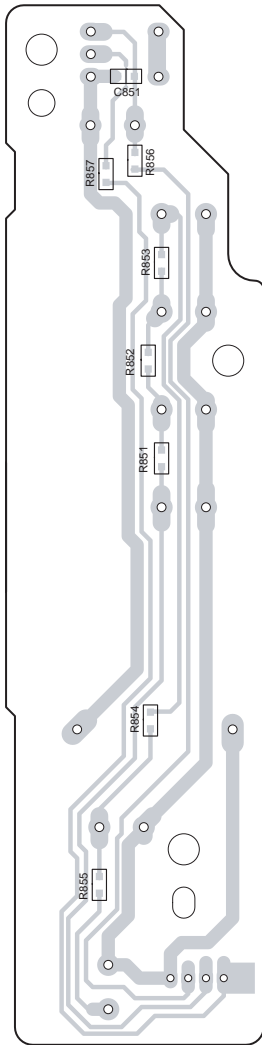

2

Component side

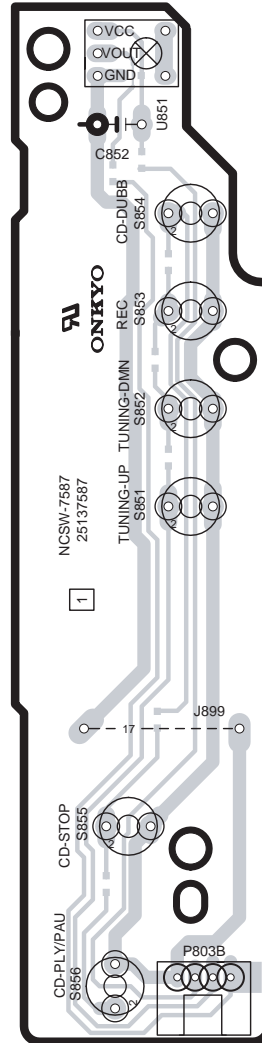

3

4

5

A

B

C

D

PRINTED CIRCUIT BOARD VIEWS-12

U6 POWER SUPPLY PC BOARD (NAPS-7553)

1

Soldering side

2

3

4

5

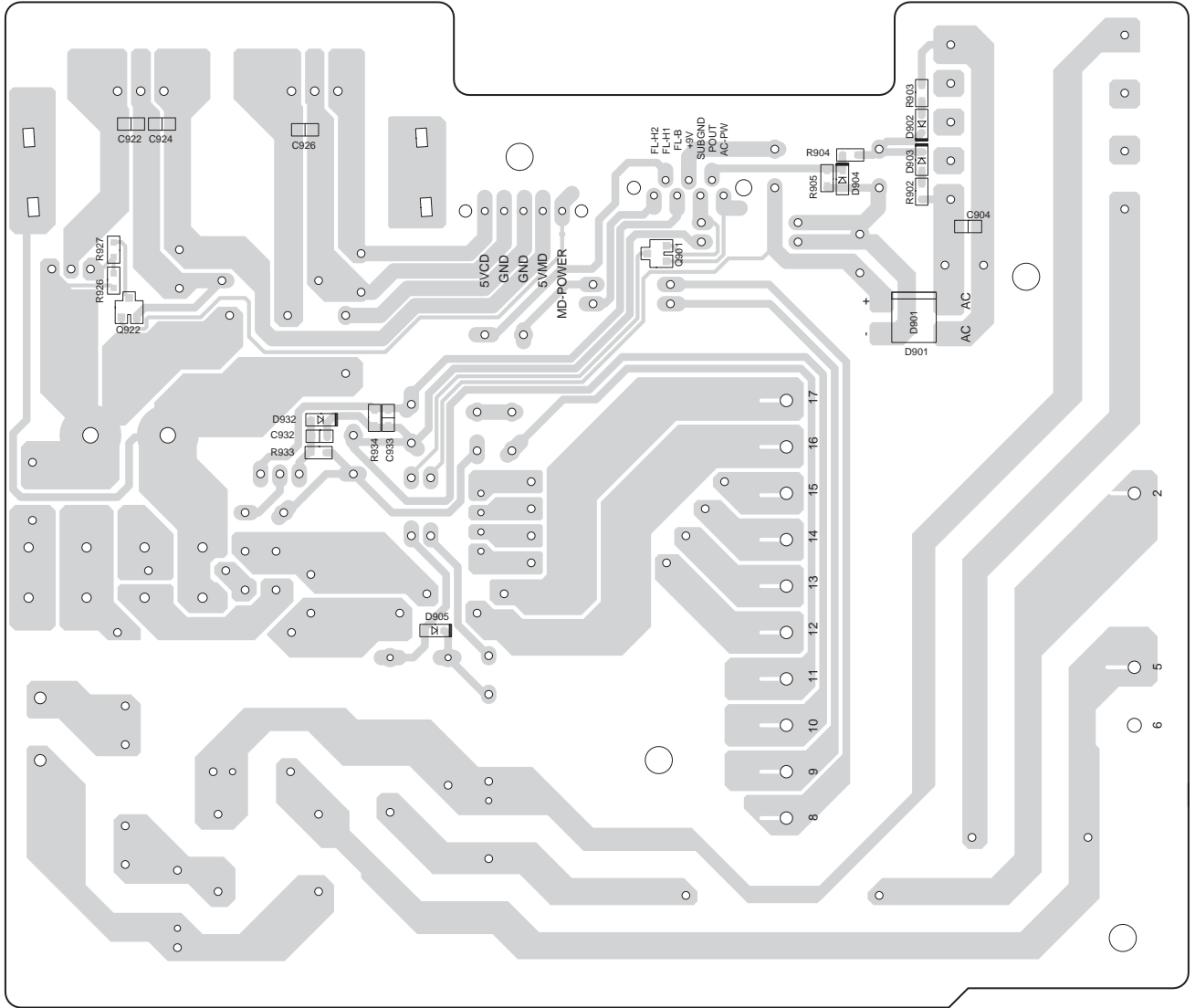

A

B

C

D

PRINTED CIRCUIT BOARD VIEWS-11

U6 POWER SUPPLY PC BOARD (NAPS-7553)

1

Component side

2

3

4

5

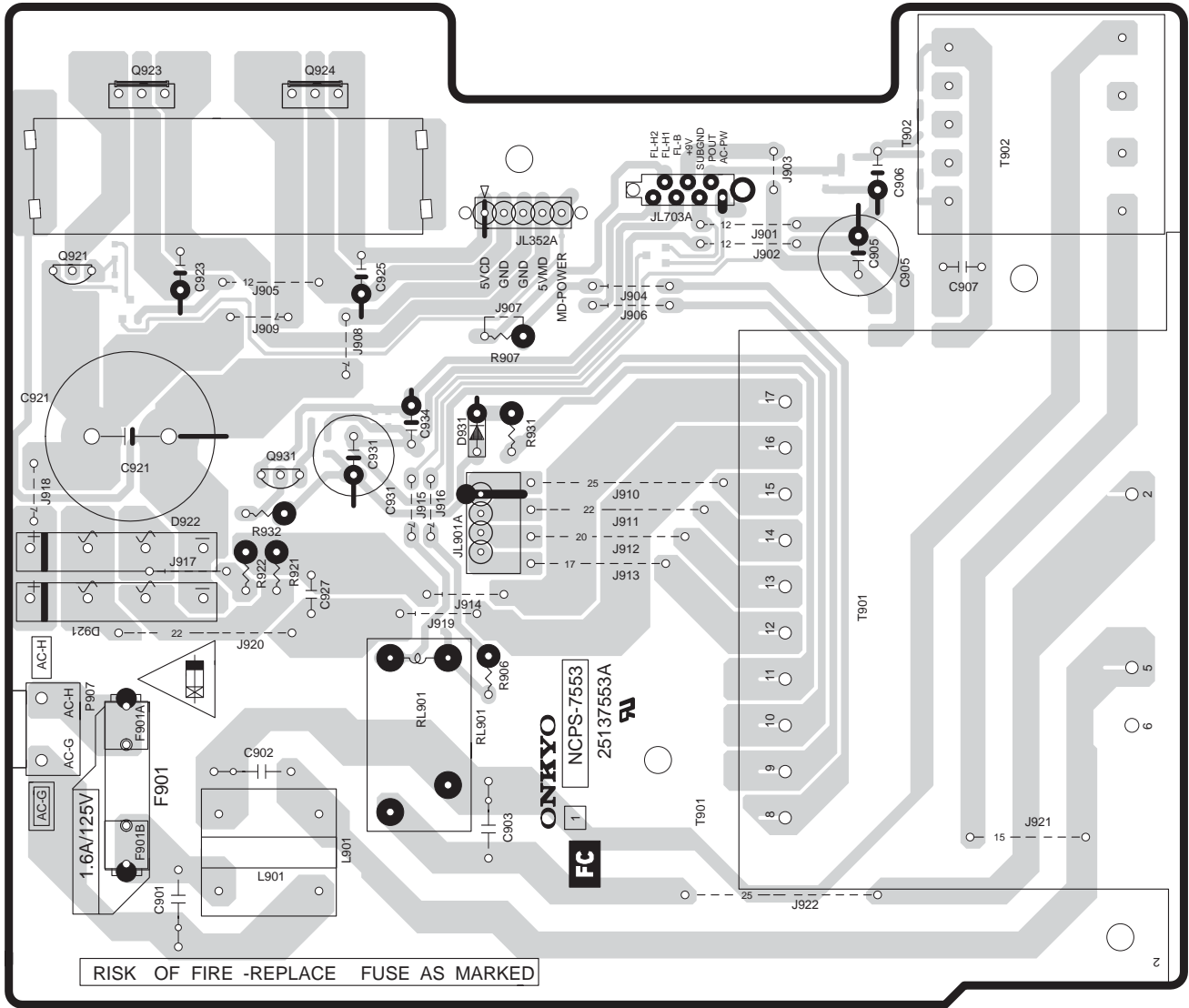

RISK OF FIRE -REPLACE FUSE AS MARKED

A

B

C

D

PRINTED CIRCUIT BOARD VIEWS-10

U2 DISPLAY PC BOARD (NADIS-7586)

1

Soldering side

2

3

4

5

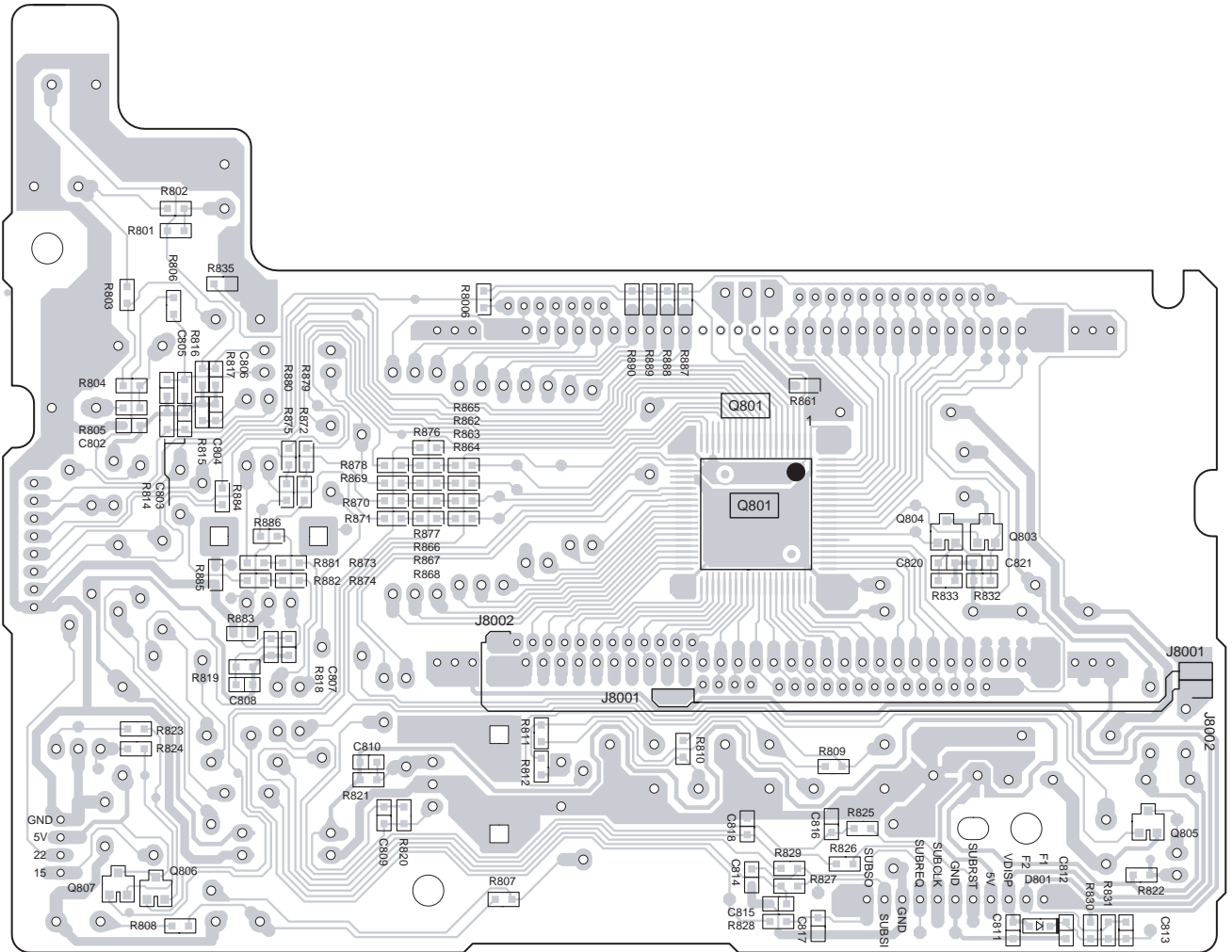

A B C D
PRINTED CIRCUIT BOARD VIEWS-1

1 **U1** PREAMPLIFIER PC BOARD (NAAF-7585)

Component side

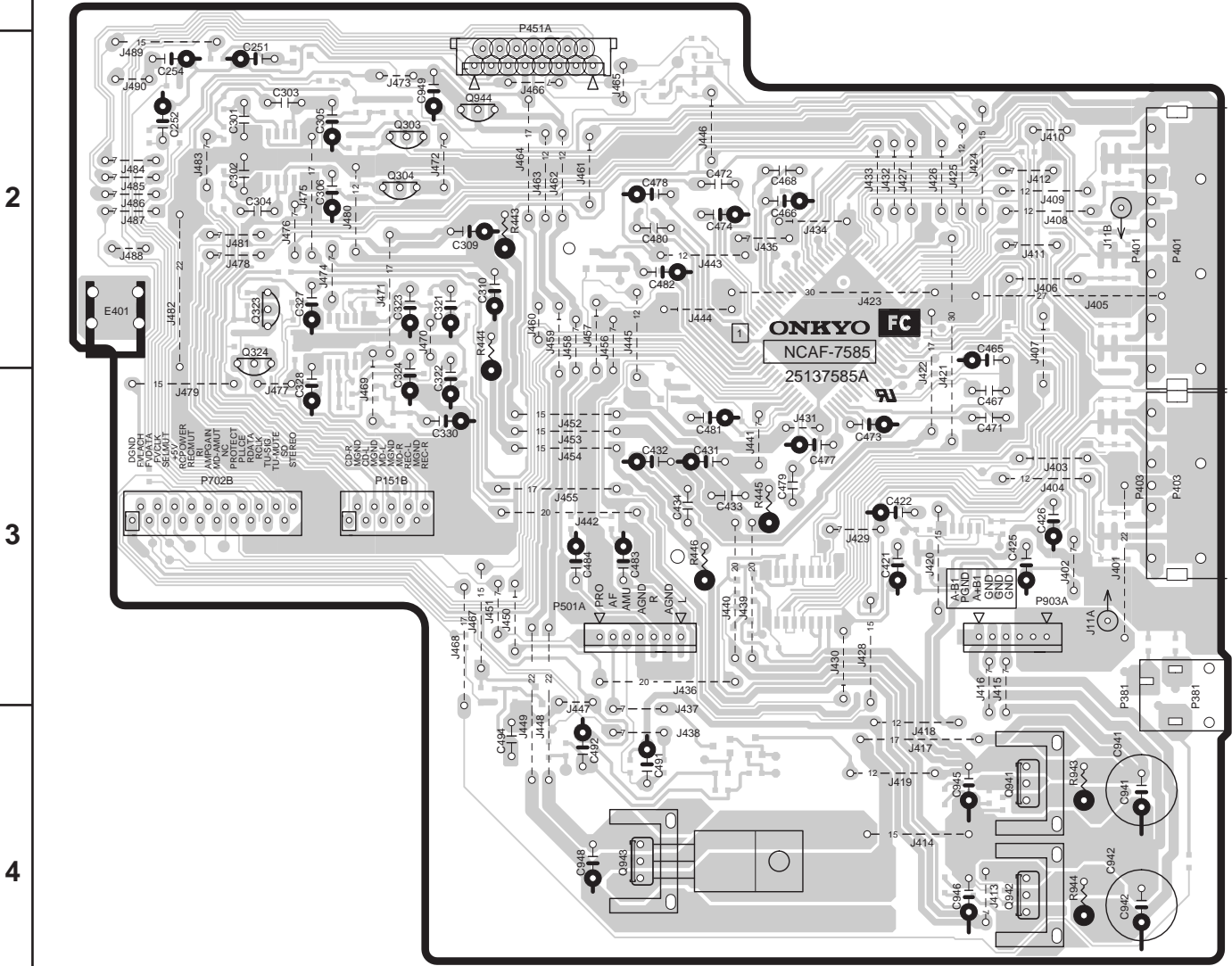

5

MICROPROCESSOR CONNECTION DIAGRAM

Q701: MPD784225GC-177-8BT

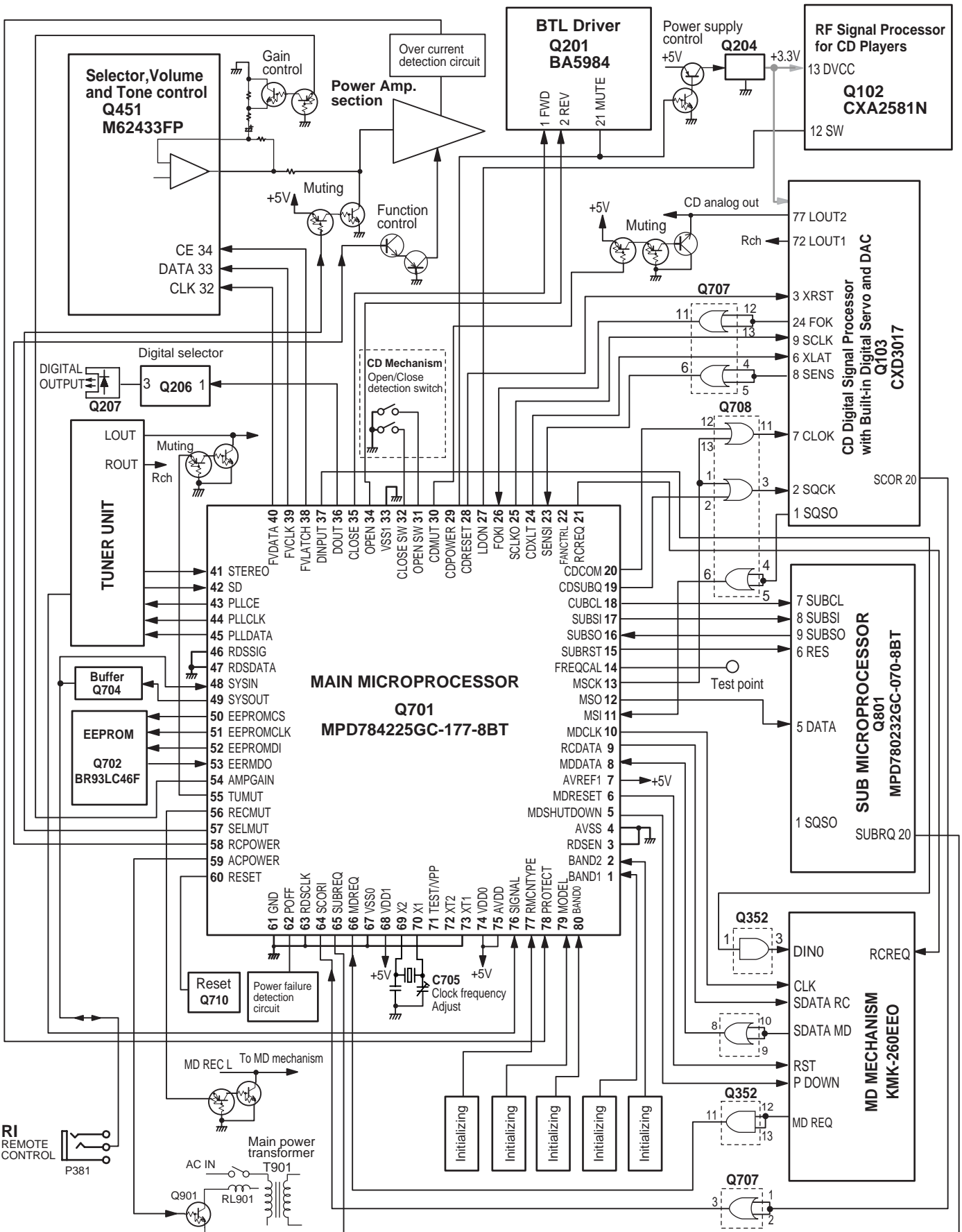

MICROPROCESSOR TERMINAL DESCRIPTIONS-1

Q7001: MPD784225GC-177-8BT

No.	PIN NAME	I/O	ACT.	DESCRIPTION
1	BAND1	I	H/L	Input pin for initializing of FM/AM band width and step.
2	BAND2	I	H/L	Input pin for initializing of FM/AM band width and step.
3	RDSEN	I	H	Input pin for initializing of RDS function. (No use)
4	AVSS	I	L	Ground pin.
5	MD SHUTDOWN	O	L	Output pin of power failure signal for MD microprocessor.
6	MD RESET	O	L	Output pin of reset signal for MD microprocessor.
7	AVREF1	I	H	Power supply for A/D converter.
8	MDDATA	I	H	Serial data input pin of from MD microprocessor.
9	RCDATA	O	H	Serial data output pin to MD microprocessor.
10	MDCLK	O	CLK	Clock data output pin for MD microprocessor.
11	MSI	I	H	Sub code input pin from CD signal processor IC (CXD3017).
12	MSO	O	H	Command data output pin for CD signal processor IC (CXD3017).
13	MSCK	O	CLK	Clock signal output pin for transfer sub code to signal processor IC (CXD3017).
14	FREQ_CAL	O	CLK	Output pin for adjustment of main clock frequency
15	SUBRESET	O	L	Reset signal output pin for sub microprocessor.
16	SUBSO	I	H	Serial data input pin from sub microprocessor
17	SUBSI	O	H	Serial data output pin for sub microprocessor
18	SUBCL	O	CLK	Serial clock output pin for sub microprocessor.
19	CDSUBQ	O	L	Signal output pin for CD subcode select.
20	CDCOM	O	L	Serial data output pin for CD signal processor IC (CXD3017).
21	RCREQ	O	L	Serial data output pin for MD microprocessor.
22	FANCTRL	O	H	No use.
23	SENS	I	H/L	Sens signal input pin from CD signal processor IC (CXD3017).
24	CDXLT	O	L	Command latch output pin for CD signal processor IC (CXD3017).
25	SCLKO	O	CLK	Clock output pin for CD signal processor IC (CXD3017).
26	FOKI	I	H	FOK signal input pin from signal processor IC (CXD3017).
27	LDON	O	H/L	Control signal output pin for laser diode of CD pickup unit.
28	CDRESET	O	L	Reset signal output pin for CD circuit IC.
29	CDPOWER	O	H	Control signal output for power supply of CD circuit.
30	CDMUT	O	H	Muting signal output pin for CD analog output signal.
31	OPENSW	I	L	Detection signal input pin for the opening completion of CD tray.
32	CLOSESW	I	L	Detection signal input pin for the closing completion of CD tray.
33	VSS1	I	L	Ground pin.
34	OPEN	O	L	Control signal output pin for tray open and close motor.
35	CLOSE	O	L	Control signal output pin for tray open and close motor.
36	DOUT	O	H/L	Control signal output pin for DIGITAL OUT select IC.
37	DINPUT	O	H	Output signal pin of recording mode (DIGITAL or ANALOG).
38	FVLATCH	O	H	Latch signal output pin for Audio control IC (M62433FP)
39	FVCLK	O	CLK	Clock output pin for Audio control IC (M62433FP)
40	FVDATA	O	H	Data output pin for Audio control IC (M62433FP)

MICROPROCESSOR TERMINAL DESCRIPTIONS-2

Q7001: MPD784225GC-177-8BT

No.	PIN NAME	I/O	ACT.	DESCRIPTION
41	STEREO	I	L	FM stereo broadcast detection input pin.
42	SD	I	L	Broadcast detection input pin.
43	PLLCE	O	H	Chip enable signal output pin for PLL IC on tuner unit.
44	PLLCLK	O	CLK	Clock data output pin for PLL IC on tuner unit.
45	PLLDATA	O	H	Data data output pin for PLL IC on tuner unit.
46	RDSSIG	I	H	Not used.
47	RDSDATA	I	H	Not used.
48	SYSIN	I	H	System code input pin.
49	SYSOUT	O	L	System code output pin.
50	EEPROMCS	O	H	Chip select signal output pin for EEPROM(BR93LC46F).
51	EEPROMCLK	O	CLK	Serial clock signal output pin for EEPROM(BR93LC46F).
52	EEPROMDI	O	H	Serial data signal output pin for EEPROM(BR93LC46F).
53	EEPROMDO	I	H	Serial data signal input pin from EEPROM(BR93LC46F).
54	AMPGAIN	O	H	Signal output pin for gain control of audio section..
55	TUMUT	O	H	Muting signal output pin for FM output signal.
56	RECMUT	O	L	Muting signal output pin for MD recording signal.
57	SELMUT	O	L	Muting signal output pin for power amplifier input signal.
58	RCPOWER	O	H	Control signal output pin for power amplifier circuit.
59	ACPOWER	O	H	Control signal output pin for main power supply.
60	RESET	I	L	Reset signal input pin for microprocessor.
61	GND	I	L	Ground pin.
62	POFF	I	L	Power failure detect input pin.
63	RDSCLK	I	CLK	Not used
64	SCORI	I	H	Sub code detection signal input pin form CD signal processor IC(CXD3017)
65	SUBREQ	I	H	Communication state signal input pin form sub microprocessor
66	MDREQ	I	L	Signal input pin for communication to MD microprocessor
67	VSS0	I	L	Ground pin.
68	VDD1	I	H	Power supply pin.
69	X2	O	CLK	Output pin for connect to oscillator.
70	X1	I	CLK	Input pin for connect to oscillator.
71	TEST	I	L	Not used.
72	XT2	O	L	Not used.
73	XT1	I	L	Not used.
74	VDD0	I	H	Power supply pin.
75	AVDD	I	H	Power supply for A/D converter.
76	SIGNAL	I	ANLG	Signal level input pin for automatic memory.
77	RMCNTYPE	I	H/L	Input pin for initializing of remote control mode.
78	PROTECT	I	H	Over current detection signal input pin for protection circuit.
79	MODEL	I	H/L	Input pin for initializing model mode. (L=FR-N3X)
80	BAND0	I	H/L	Input pin for initializing of FM/AM band width and step.

DISASSEMBLING PROCEDURES (CD) -1

CD MECHANISM : REPLACEMENT OF OPTICAL PICKUP

The laser diode in the optical pickup block is so sensitive to static electricity, surge current and etc. That the components are liable to be broken down or its reliability remarkably deteriorated. During repair, carefully take the following precautions.

When you remove CD mechanism, please be sure to perform optical pickup short-circuit before removing the connection line between an optical pickup and CD & microcomputer board (NADG-7557).

- 1** In exchanging optical pickups, remove the plate(s) at the bottom of the set first. And jumper wire in CD connector board is short-circuited with solder.

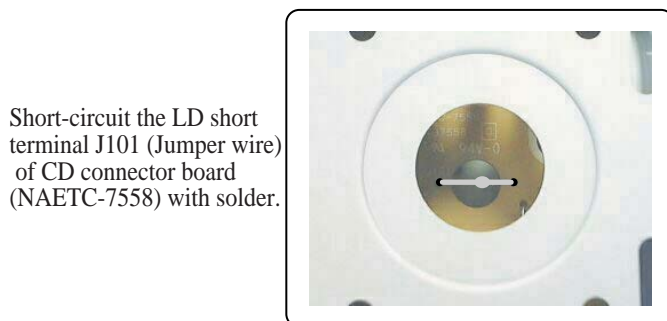
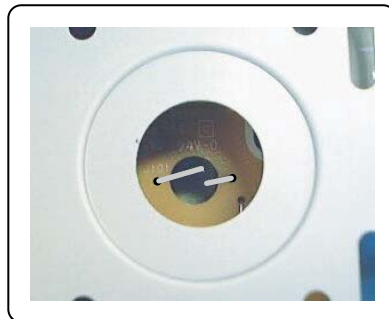
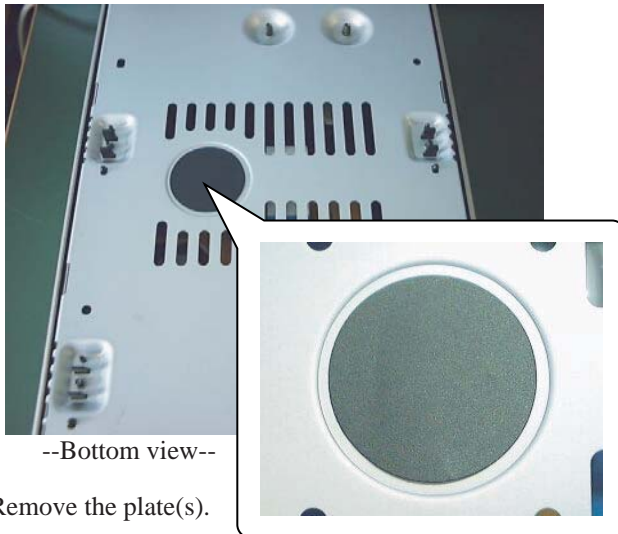

Short-circuit the LD short terminal J101 (Jumper wire) of CD connector board (NAETC-7558) with solder.

- 2** 1. Remove the MD mechanism and front section from main chassis.
2. Remove the bracket (CD).

- 3** Remove the four screws which fix CD mechanism.

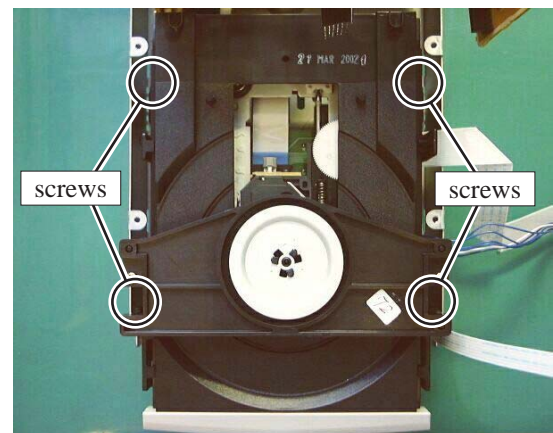

--Top view--

- 4** Remove the CD mechanism form main chassis.

- 5** Remove the two screws which fix CD connector PC board.

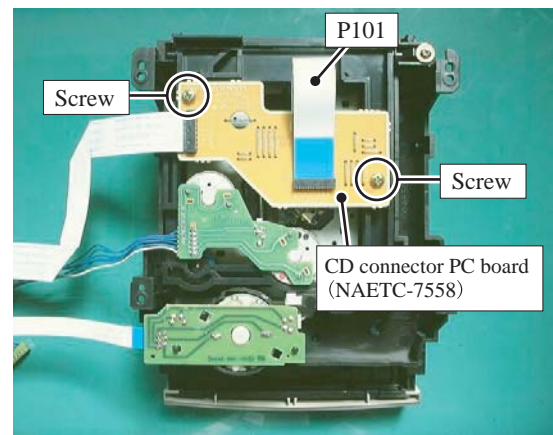

--Bottom view of CD mechanism--

[NONE]

Must not remove the Flat cable P101 yet at this time.

DISASSEMBLING PROCEDURES (CD) -2

CD MECHANISM : REPLACEMENT OF OPTICAL PICKUP

- 6** Short-circuit two LD short terminals on the optical pickup unit with solder.

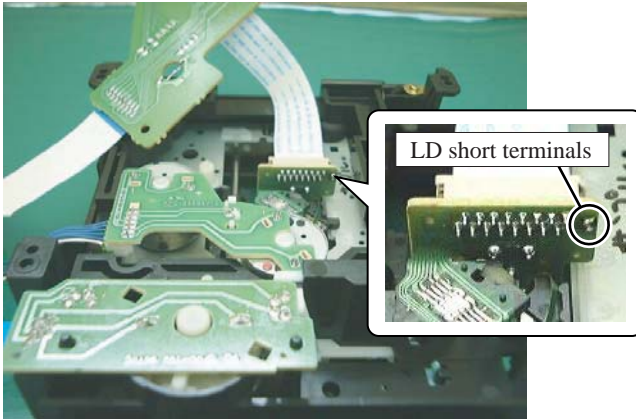

--Bottom view of CD mechanism--

- 8** Move the lever to left side.

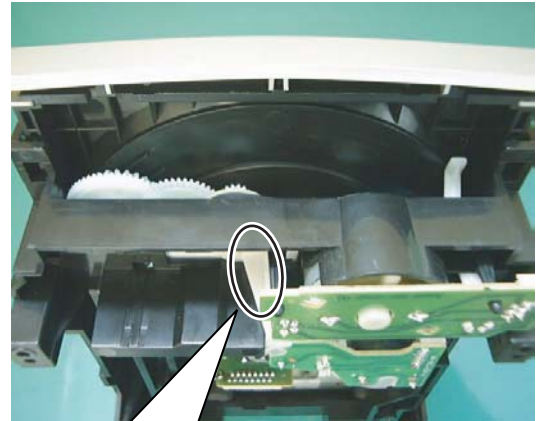

- 7** Disconnect the two flat cables.

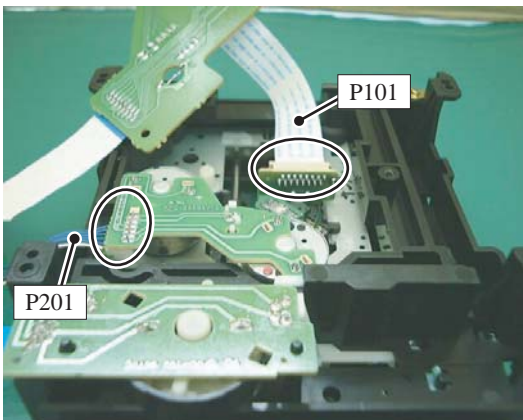

--Bottom view of CD mechanism--

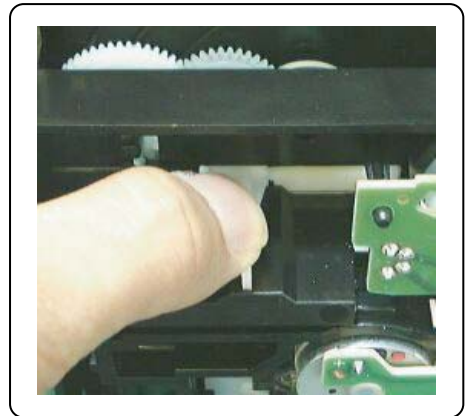
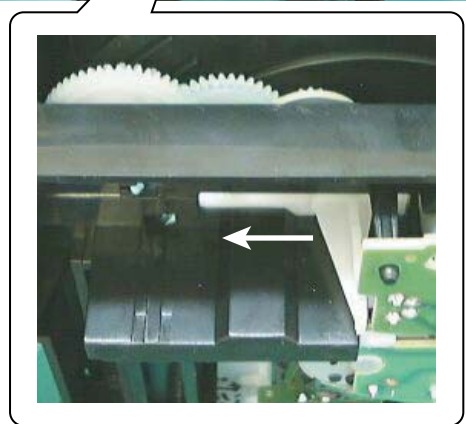

[NOTE]

Do not crease the flat cable.
Because flat cable may be damaged.

DISASSEMBLING PROCEDURES (CD) -3

CD MECHANISM : REPLACEMENT OF OPTICAL PICKUP

- 9** Remove the screw which fixed CD drive unit.

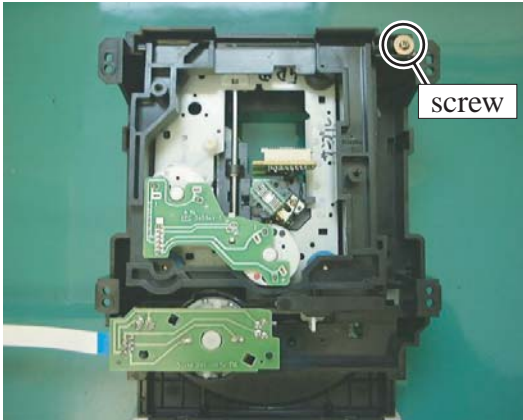

CD drive unit

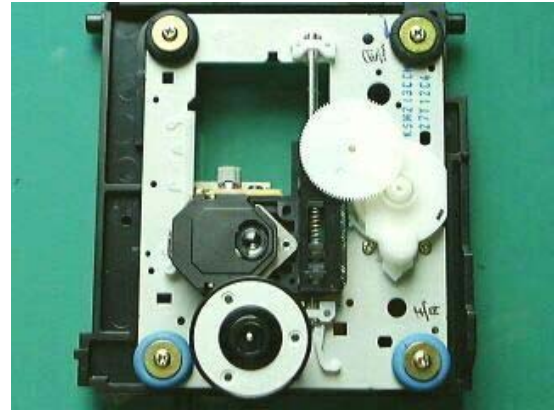

- 10** Remove the drive unit by opening the stopper in the direction of arrow mark.

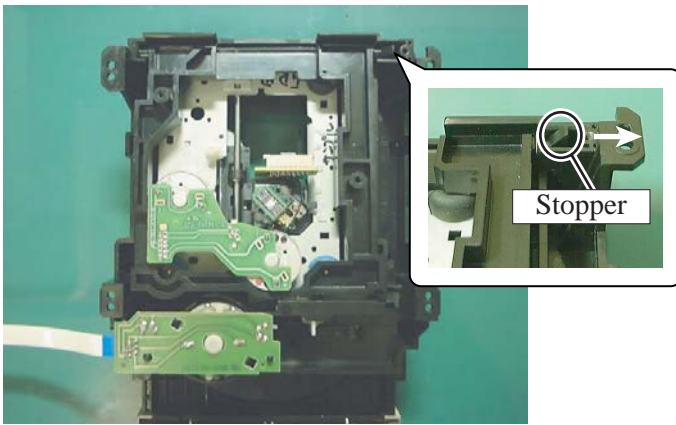

- 11** Push the gear stopper.



--Bottom view of CD mechanism--

Font side →



- 12** Remove the gear.

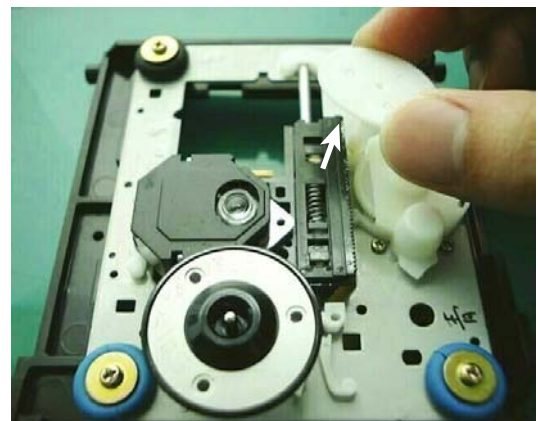
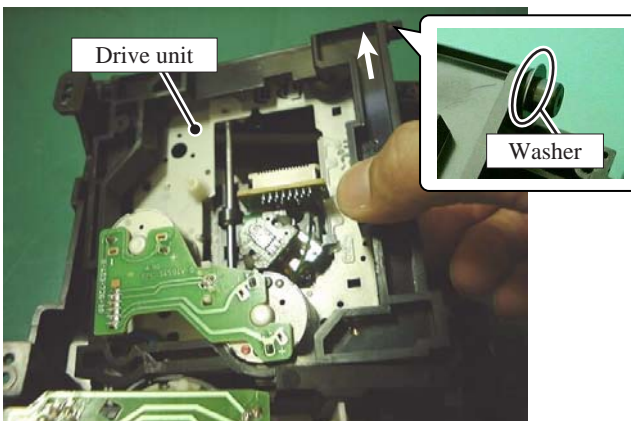

Front side ↓

[NOTE]
When assembling, do not forget to attach the washer.

DISASSEMBLING PROCEDURES (CD) -4

CD MECHANISM : REPLACEMENT OF OPTICAL PICKUP

- 13** Pull out the shaft, opening the shaft stopper in the direction of arrow mark.

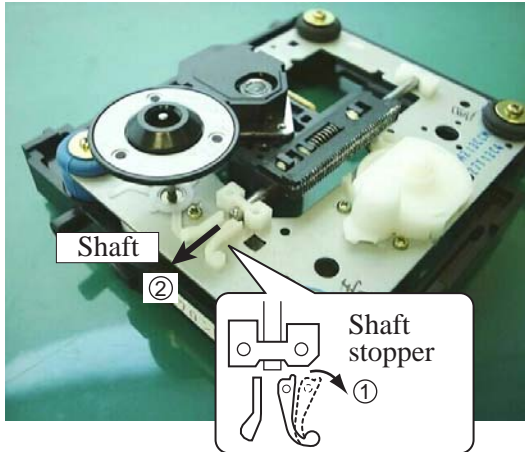

- 2** Do not bend the flat cable.

- 3** Solder the LD short terminals J101 (Jumper wire) of bottom of the unit, after ending all assembly of unit.

- 14** Replacement of optical pickup unit.



[Notes in re-assembling]

- 1** Remove the solder of LD short terminals after connecting the flat cable P101 to the socket.

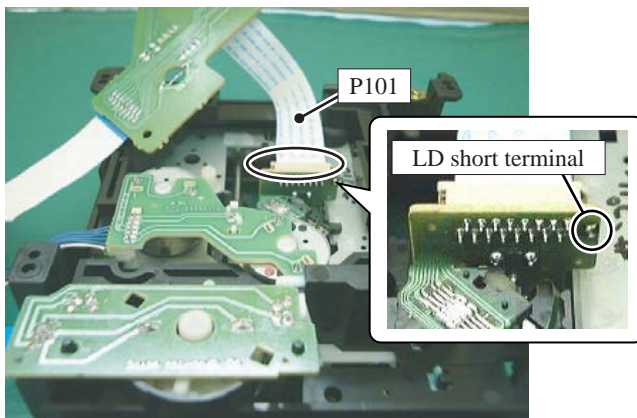

--Bottom view of CD mechanism--

DISASSEMBLING PROCEDURES (CD) -5

CD MECHANISM : REPLACEMENT OF DRIVE BELT

1 Works **1** ~ **4** in the
DISASSEMBLING PROCEDURES (CD) -1.

2 Remove the two screws which fixed Clamper ass'y-C.

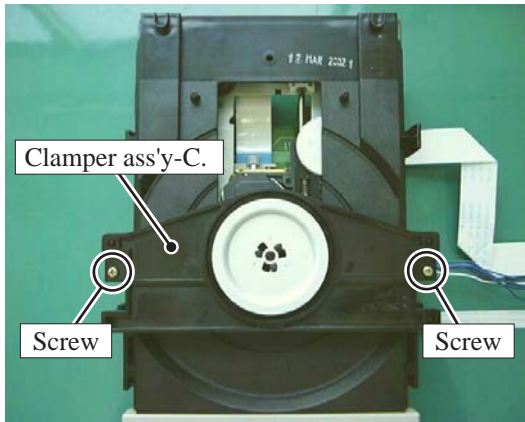

--Top view--

3 Remove the Spring tray, Bias-C.

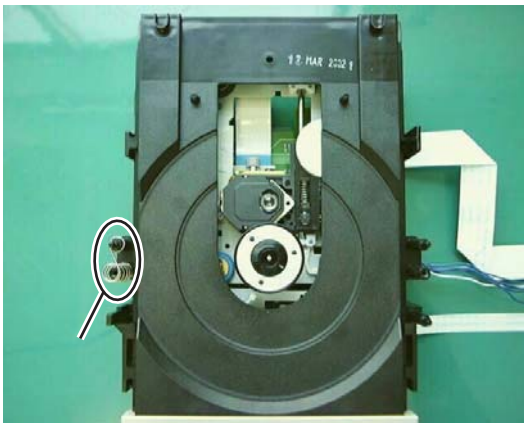

--Top view--

4 Move the lever to left side.

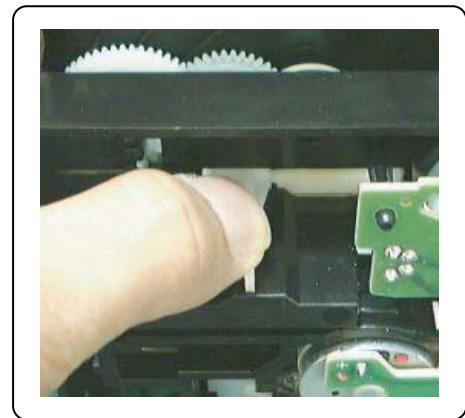
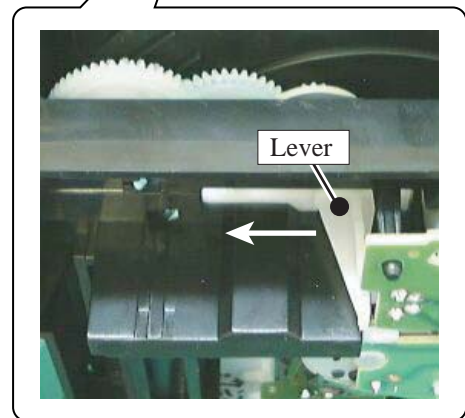
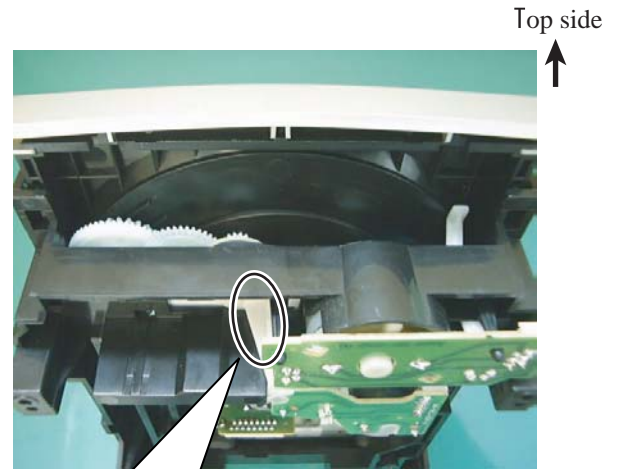

DISASSEMBLING PROCEDURES (CD) -6

CD MECHANISM : REPLACEMENT OF DRIVE BELT

5 Pull out the tray (Table disk-C) to the front side.

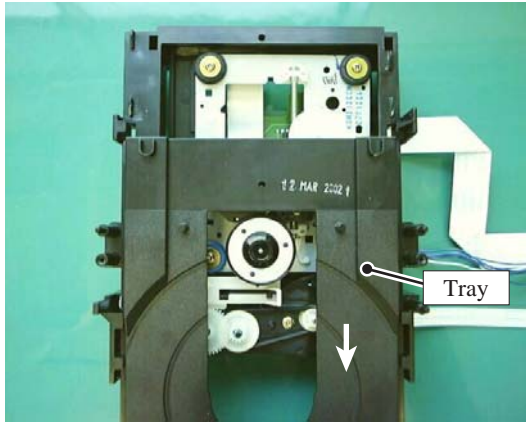

--Top view--

7 Replacement the drive belt.

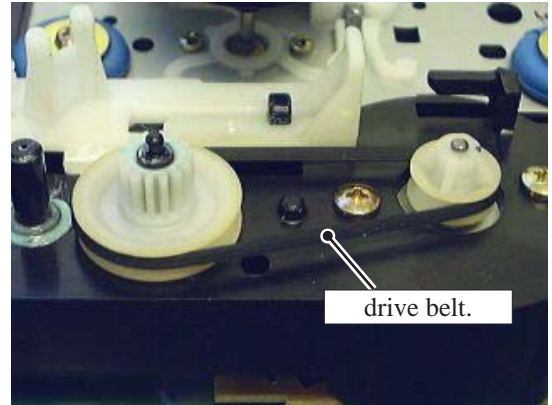

--Top view --

Front side

6 1. Remove the gear (Gear and Loading), pushing the gear stopper in the direction of the arrow.
2. Remove the gear (Gear, Connector).

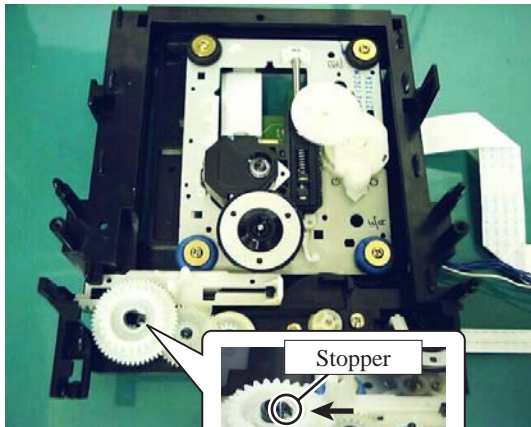

Front side

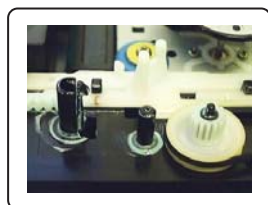
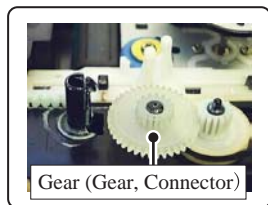
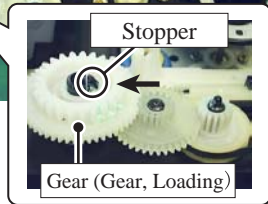

DISASSEMBLING PROCEDURES (CD) -7

CD MECHANISM : REPLACEMENT OF DRIVE BELT

[Notes of re-assembly]

- 1** Check the lever position is at the left end.

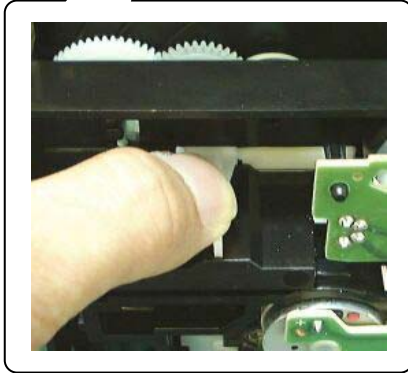
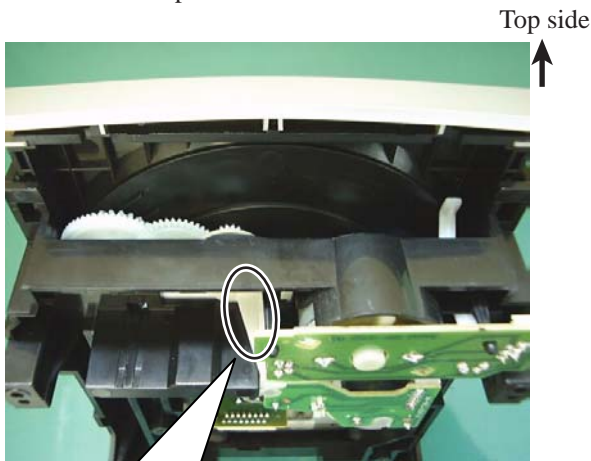

Move to left end.

- 2** Confirm the position of marking, when attaching the gear (Gear and Loading).

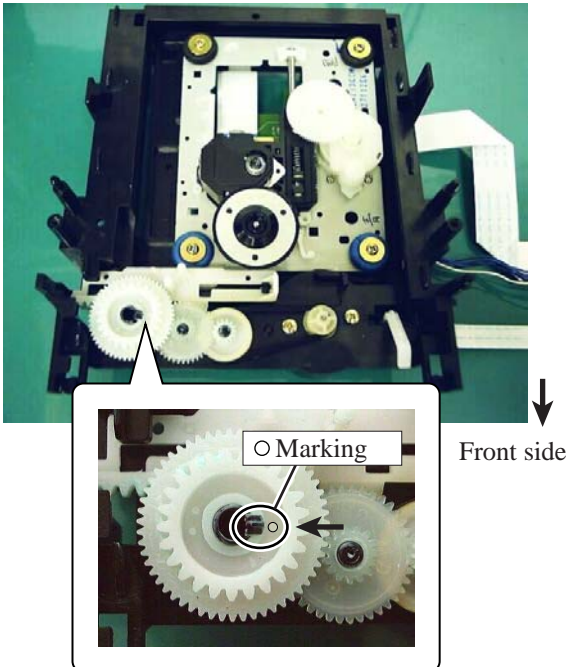

-- Top side view--

- 3** Attach the Tray (Table disk-C).

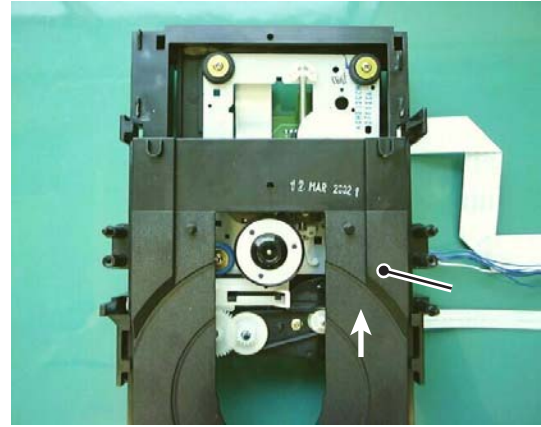

-- Top side view--

[NOTES]

Even if the tray closes completely, the lever does not move to right end.
Therefore, move the lever to right end by hand.

- 4** Check the marking on the opposite side of the gear and the position of \triangle mark are in agreement.

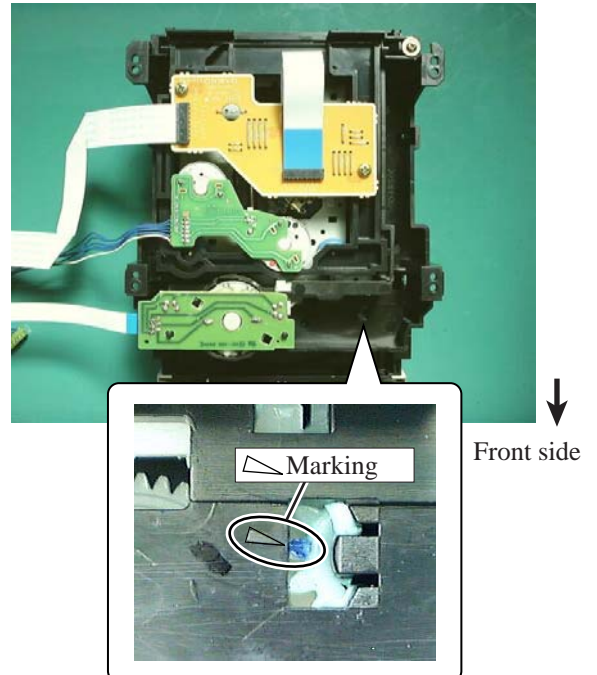

--Bottom side view--

DISASSEMBLING PROCEDURES (CD) -8

CD MECHANISM : REPLACEMENT OF DRIVE BELT

[Notes of re-assembly] (continuation)

- 5** Attach the spring.

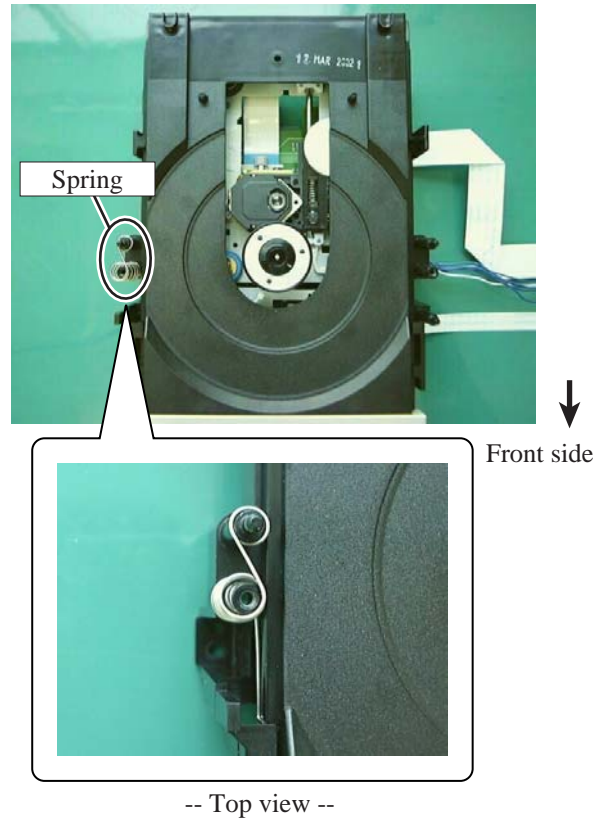

- 6** Attach the Clamper AS (Clamper ass'y-C).

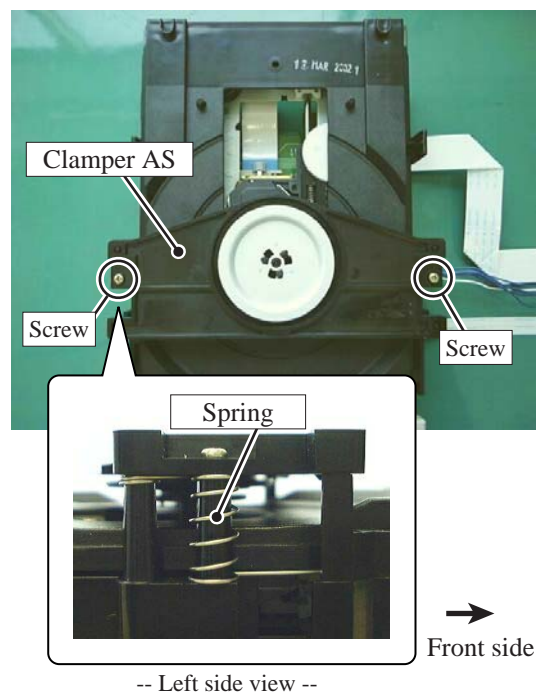

ADJUSTMENT PROCEDURES-1

MD ADJUSTMENT

1. Necessity for adjustment

○ necessary × unnecessary

Adjustment item	Exchanged parts			
	Pickup unit	Parts on MD mount, and Motors	Mechanical parts	
6-1 Adjustment of Temperature Compensation Offset	×	○	○	
6-2 Adjustment of laser power	○	○	○	
6-3 Check of laser power	○	○	○	
6-4 Adjustment of Traverse (EF balance)	○	○	○	
6-6 Check of error rate in high reflectance disk	○	○	○	
6-7 Check of error rate in low reflectance disk	○	○	○	
Adjustment of focus Bias	×	×	×	
Check of focus bias	×	×	×	

2. Notes in adjustment

2-1. Laser of optical pickup

In case adjust, don't look at the laser of the pickup unit.
You have fear of loss of eyesight.

2-2. Perform adjustment using test mode.

2-3. Perform adjustment as the indicated turn.

2-4. After adjustment should cancel test mode.

3. Equipment

3-1. Measuring instruments

Name	Manufactured	Description and remarks
Laser power meter	LEADER	LE8010
Optical sensor	LEADER	LP-8010-02
Oscilloscope	---	Frequency range is 40MHz or more. The calibration of the probe is performed.
Digital volt meter	---	

3-2. Test disks

Name	Manufactured	Description and remarks
MO disk	---	Standard disk for recording/play back
High reflectance disk	A-BEX	TDM-381 Test disc

3-3. JIGs

Name	Part No.	Details		Remarks
Extended JIG	0J12	PC board	Part No. NCJIG-0J12	
		FFC socket	Part No. 25052307	
Flexible flat cable	0F001	1mm pitch, 7 cores	---	
Extended JIG	0J16	PC board	Part No. NCJIG0J16	
		FFC socket, 7 cores	Part No. 25051759A	Black
		FFC socket, 13 cores	Part No. 25052313	Gray
		Flexible flat cable (13cores)	Part No. 2045131012	

ADJUSTMENT PROCEDURES-2

MD ADJUSTMENT

4. Test mode

4-1. How to test mode to enter

- (1) Connect the power supply cord in the wall socket.
- (2) Turn on power by Pressing Press STANDBY/ON.
- (3) Select the MD by pressing the CD/MD.
FL display ---"No Disc"
- (4) While hold down MODE/YES button, press DISPLAY.
FL display --- For example "020328EXX-a"
- (5) Press STANDBY/ON.
When the unit is not a clock display at this time, continue pushing STANDBY/ON again and set the state of a clock display.
FL display --- " -: - : - - "
- (6) While hold down MODE/YES, press the MD EJECT.

FL Display
TEMP ADJUST

4-2. How to cancel test mode

Disconnect the power supply cord from the wall socket.

4-3. Cautions on Test Mode

- (1) Don't use the disk which you must not eliminate in test mode.
- (2) Push the EJECT button after pressing EDIT/CLEAR/NO, when taking out disk in test mode.

4-4. Basic operation in Test Mode

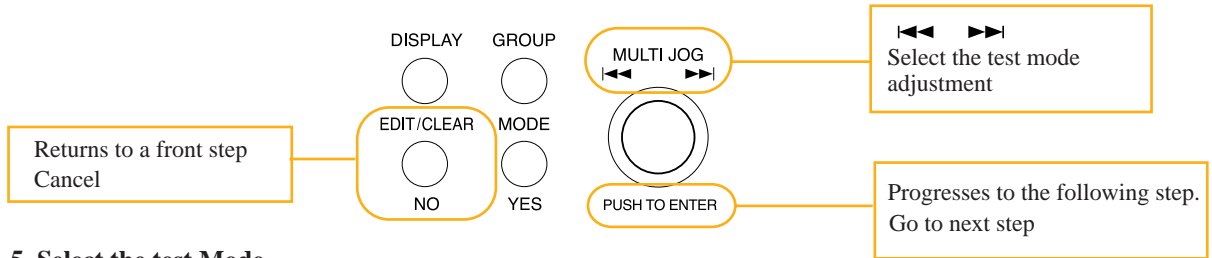

4-5. Select the test Mode

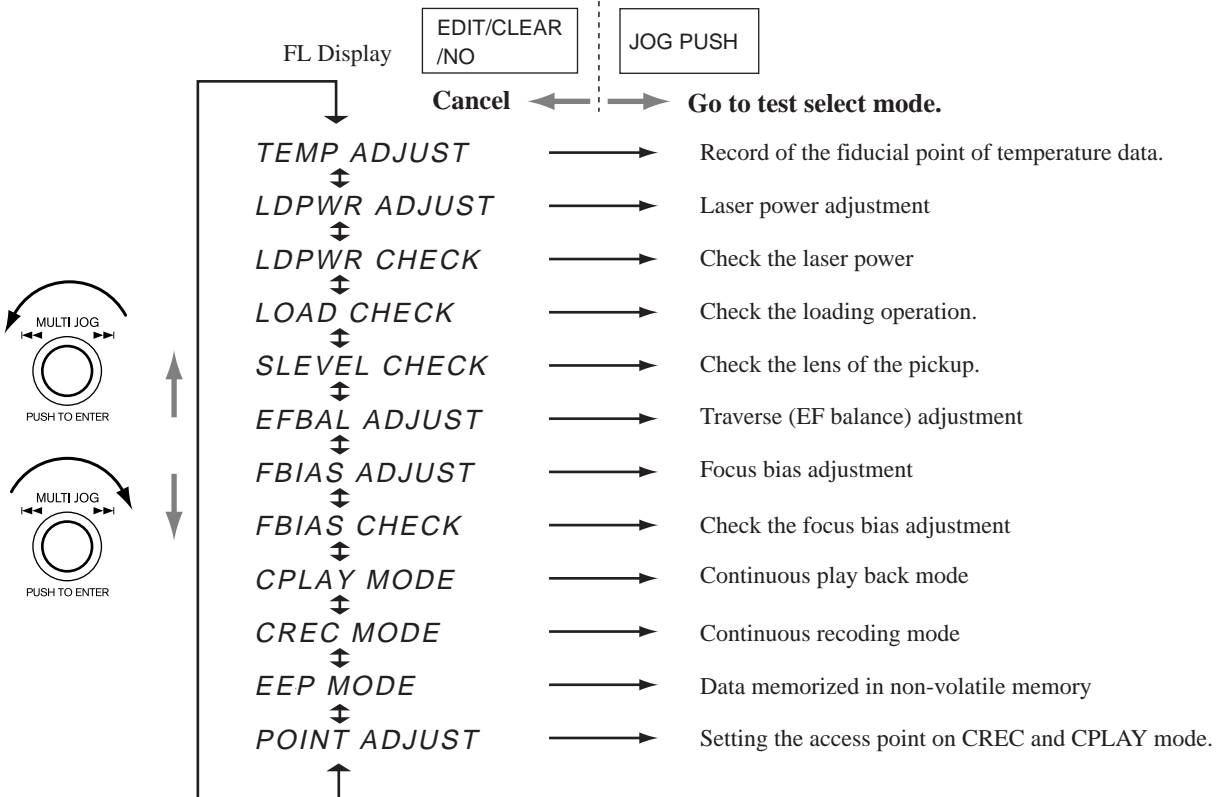

ADJUSTMENT PROCEDURES-3

MD ADJUSTMENT

5. Preparation

5-1. Make the extended JIG and connection.

Connect JIG based on the following figure.

Back side view of MD mechanism

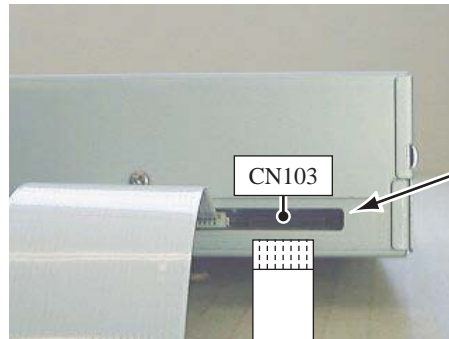

Connect to CN103 (Test point).

Notes

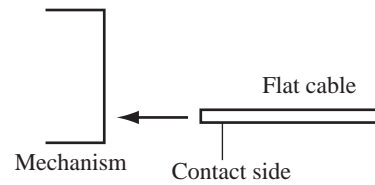

Extended JIG (KIT)
Part No. 0J16

Flexible flat cable
Part No. 2045131012

FFC Socket (Gray)
Part No.25052313

FFC Socket (Black)
Part No.25051759A

PC board
Part No. NCJIG0J16

Flexible flat cable
Part No. 0F001

Extended JIG (KIT)
Part No. 0J12

Flexible flat cable
Part No. 0F001

FFC Socket (Gray)
Part No.25052307

Jumper wires
5mm x 2pcs

PC board
Part No. NCJIG-0J12

Notes

1. Attach the wire to required point so that it may be easy to connect measuring instrument etc.
2. WP and FE terminal : No use

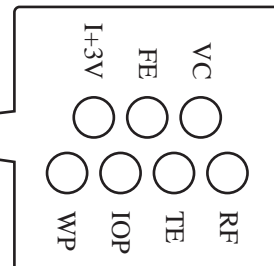

ADJUSTMENT PROCEDURES-4

MD ADJUSTMENT

6. The adjustment method

6-1 Adjustment of temperature compensation value

[NONE]

- (1) Perform circumference temperature in the 22 to 28 degrees state.
- (2) Adjust, after exchanging D101, and the temperature of this part turns into the same temperature as circumference temperature.

[Adjustment]

- (1) Select the *TEMP ADJUST* in the test mode state.

FL display

TEMP ADJUST

- (2) Press MULTI JOG.

TEMP= &&

- (3) Press MULTI JOG.

TEMP= &&SAVE



TEMP ADJUST

ADJUSTMENT PROCEDURES-5

MD ADJUSTMENT

6-2 Adjustment of laser power

[Preparation]

- (1) Connect the digital volt meter to I+3V and IOP on Extended JIG.
- (2) Set the optical sensor to laser power meter.
- (3) Loading of the optical sensor to the unit at test mode state.

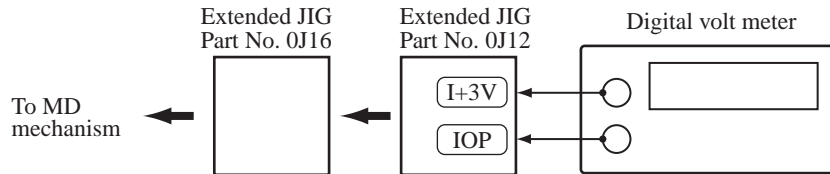

[Adjustment]

- (1) Turns MULTI JOG, and select the *LDPWR ADJUST* mode.
- (2) Press MULTI JOG.
- (3) Turn MULTI JOG, adjust so that reading of the laser power meter becomes 0.92mW.

LDPWR ADJUST

LD 0.9mW \$XX

LD 0.9mW \$XX

[Note]

Do the work to (5)-(7) within 15 seconds.

Since continuation luminescence of the 7mW laser power is carried out, if it is left for a long time, the pickup will deteriorate.

- (4) Press MULTI JOG.

LD SAVE \$XX

LD 7.0mW \$XX

- (5) Turn MULTI JOG, adjust so that reading of the laser power meter becomes 7.2mW.
- (6) Press MULTI JOG.

LD 7.0mW \$XX

LD SAVE \$XX

LD 0.9mW \$XX

- (7) Press EDIT/CLEAR/NO.

LDPWR ADJUST

6-3 Check of laser power

Continue at 6-2(Adjustment of laser power) and do this work.

- (1) Turns MULTI JOG, and select the *LDPWR CHECK* mode.
- (2) Press MULTI JOG.
- (3) Checks that reading of laser power meter is 0.92mW.
- (4) Press MULTI JOG.
- (5) Checks that reading of laser power meter is 7.2 mV.
- (6) Measure a laser current value (V) in digital bolt meter. Calculate laser current value (I) and compare with the display of the label(I_d) on pickup unit. (Fig-1)

$$I \text{ (mA)} = V / 1 \text{ (ohm)}$$

Check that the laser current value(I) is I_d(mA) ±10%.

Notes

The current value may be large if the pickup has deteriorated.

- (7) Press the EDIT/CLEAR/NO button after check.
- (8) Press EJECT and takes out the optical sensor.
- (9) Remove the digital volt meter from JIG.

LDPWR CHECK

LD 0.9mW \$XX

LD 7.0mW \$XX

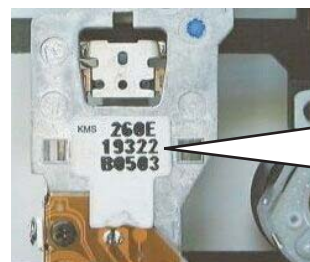

Fig-1

label display of pickup

LDPWR CHECK

ADJUSTMENT PROCEDURES-6

MD ADJUSTMENT

6-4 Adjustment of traverse (EF balance)

[Preparation]

- (1) Connect oscilloscope to TE and VC on Extended JIG.
- (2) Loading the MO disk to the unit.

[NOTE]

Do not connect the VC to the GND of the unit at test mode state.

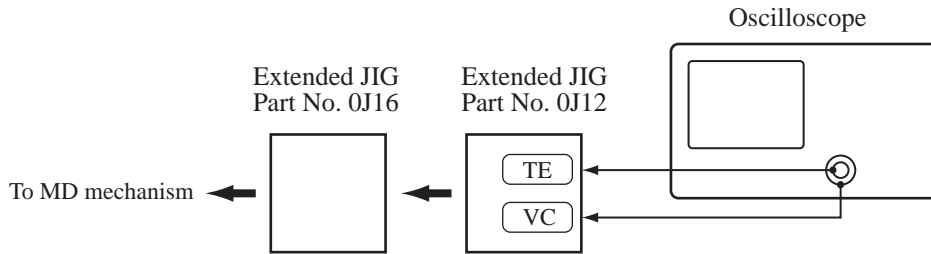

[Adjustment]

- (1) Turns MULTI JOG, and select to *EFBAL ADJUST*.
- (2) Press MULTI JOG.
- (3) Turn MULTI JOG, adjust so that reading of the waveform currently observed with the oscilloscope should be as follows.

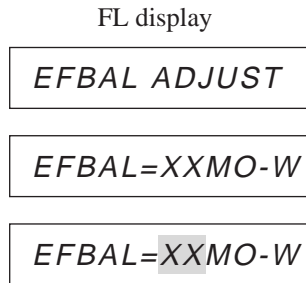

Adjusted so that it may grow into **A=B**.

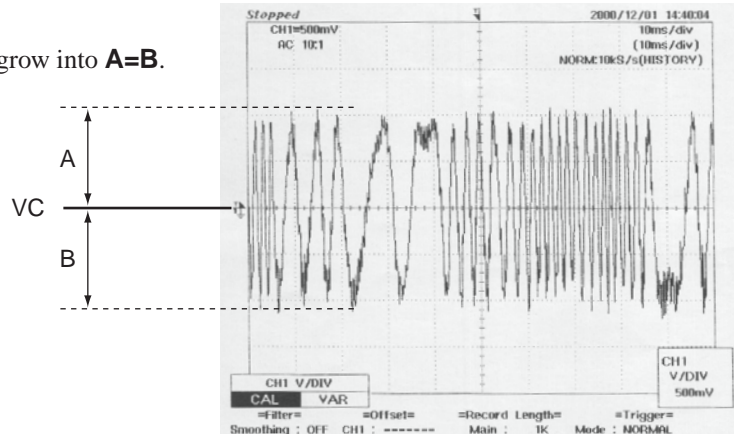

- (4) Press MULTI JOG.

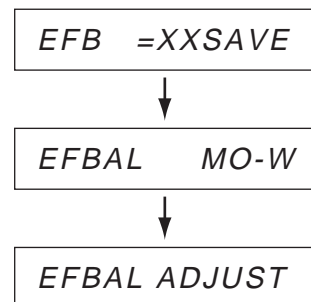

- (5) Remove the oscilloscope and extended JIG from MD mechanism.
- (6) Take out disk from the unit by pressing EJECT.

ADJUSTMENT PROCEDURES-7

MD ADJUSTMENT

6-5 Make the continuation recording disk

For check of the error rate.

[Preparation]

- (1) Loading of the MO disk to the unit at test mode state.

[Procedure]

- (1) Turns MULTI JOG and select the *CREC MODE* at test mode.

CREC MODE

- (2) Press MULTI JOG.
Recording start in outer track of disk.

CREC OUT



CREC (0700)

- (3) Press MULTI JOG after recording outer track for several minutes.
Recording start in inner track of disk.

CREC IN



CREC (0040)

- (4) Press MULTI JOG after recording inner track for several minutes.
Recording start in middle track of disk.

CREC MID



CREC (0300)

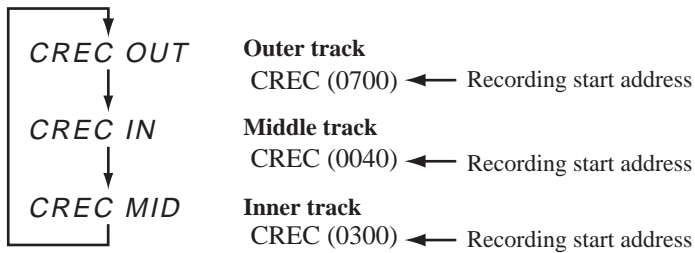

- (5) Press MD STOP after recording completes.

CREC MODE

- (6) Press EDIT/CLEAR/NO and finish
CREC MODE.

ADJUSTMENT PROCEDURES-8

MD ADJUSTMENT

6-6 Check of the error rate by the high reflectance disk

[Preparation]

- (1) Loading of the high reflectance disk (TMD-381/A-BEX) to the unit at test mode state.

[Check]

- (1) Turns MULTI JOG and select *CPLAY MODE* at test mode state.
 (2) Press MULTI JOG.

CPLAY MODE

- (3) Checks that the value of C1 error rate is the value less than 20.

This value is usually less than 10.

- (4) Press MULTI JOG and check the error rate at outer track of disk(CPLAY OUT)

CPLAY MID

C1=XXXXAD=

C1 error rate

- (5) Press MULTI JOG and check the error rate at inner track of disk
 (6) Press the MD STOP.

CPLAY OUT

C1=XXXXAD=

CPLAY IN

C1=XXXXAD=

- (7) Press EDIT/CLEAR/NO.
 (8) Take out disk from the unit by pressing EJECT.

CPLAY MODE

6-7 Check of the error rate by the MO disk

[Preparation]

- (1) Loading of the continuation recording disk to the unit at test mode state.

Refer to **ADJUSTMENT PROCEDURES-7** about how to make continuation recording

[Check]

- (1) Turns MULTI JOG and select *CPLAY MODE* at test mode state.
 (2) Press MULTI JOG.

CPLAY MODE

- (3) Checks that the value of C1 error rate is the value less than 20.

This value is usually less than 10.

- (4) Press MULTI JOG and check the error rate at outer track of disk(CPLAY OUT)

CPLAY MID

C1=XXXXAD=00

C1 error rate

- (5) Press MULTI JOG and check the error rate at inner track of disk
 (6) Press the MD STOP.

CPLAY OUT

C1=XXXXAD=00

CPLAY IN

C1=XXXXAD=00

- (7) Press the EDIT/CLEAR/NO.
 (8) Take out disk from the unit by pressing EJECT.

CPLAY MODE

ADJUSTMENT PROCEDURES-9 CLOCK FREQUENCY ADJUSTMENT

1. Remove the top cover.
2. Connect the frequency counter to the Test point on CD & microprocessor PC board (NADG-7557)
3. While hold down CD STOP key, press STANDBY/ON key to set the test mode.
(All segments on FL tube light on and scroll the character for FL tube test.)
4. Adjust the trimmer capacitor C705 on NADG-7557 so that the reading of frequency counter becomes $12.500\text{MHz} \pm 100 \text{ Hz}$.

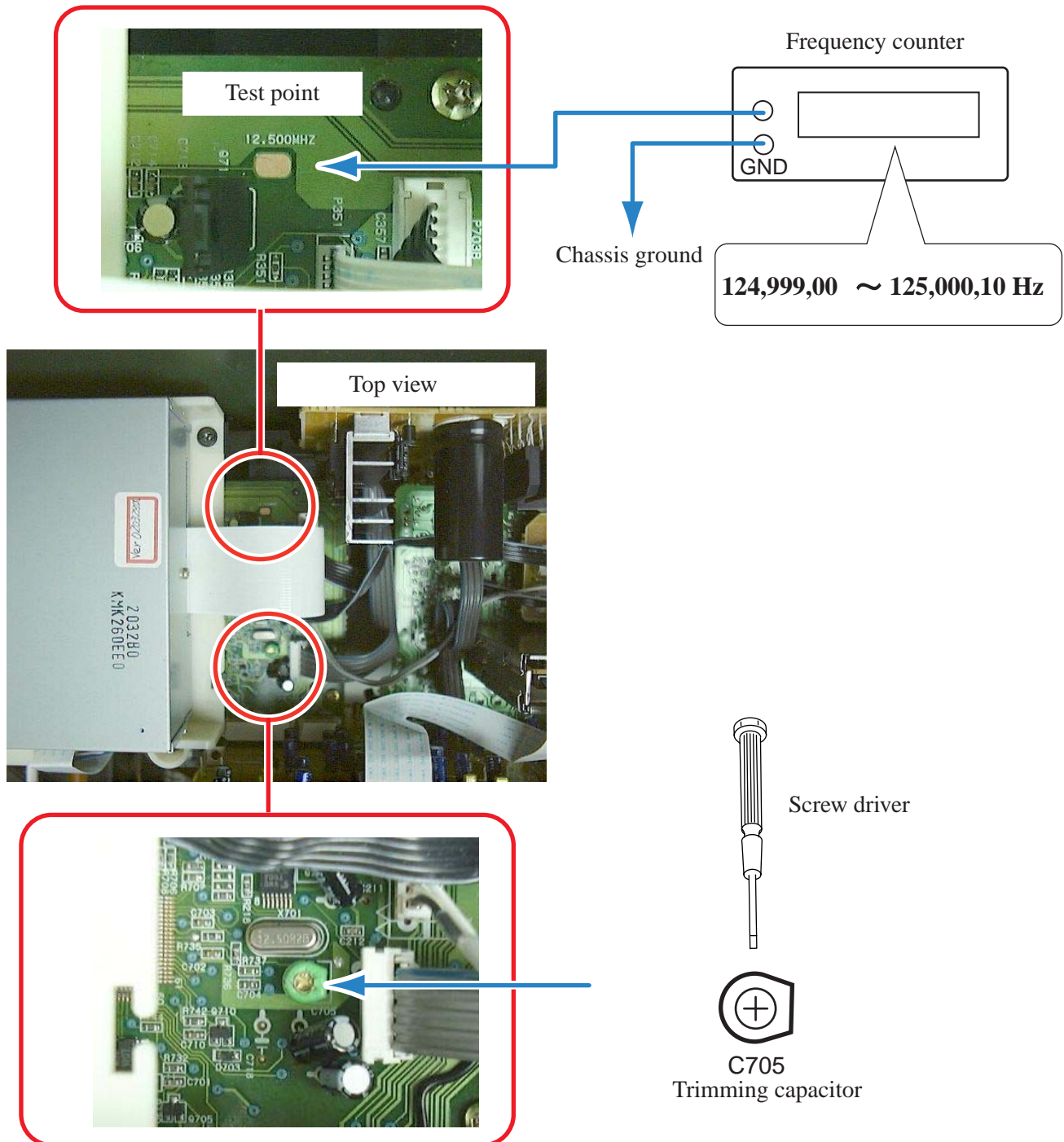

PACKING VIEWS-1

Please refer to **PACKING PROCEDURES-2** about the packing of accessories.

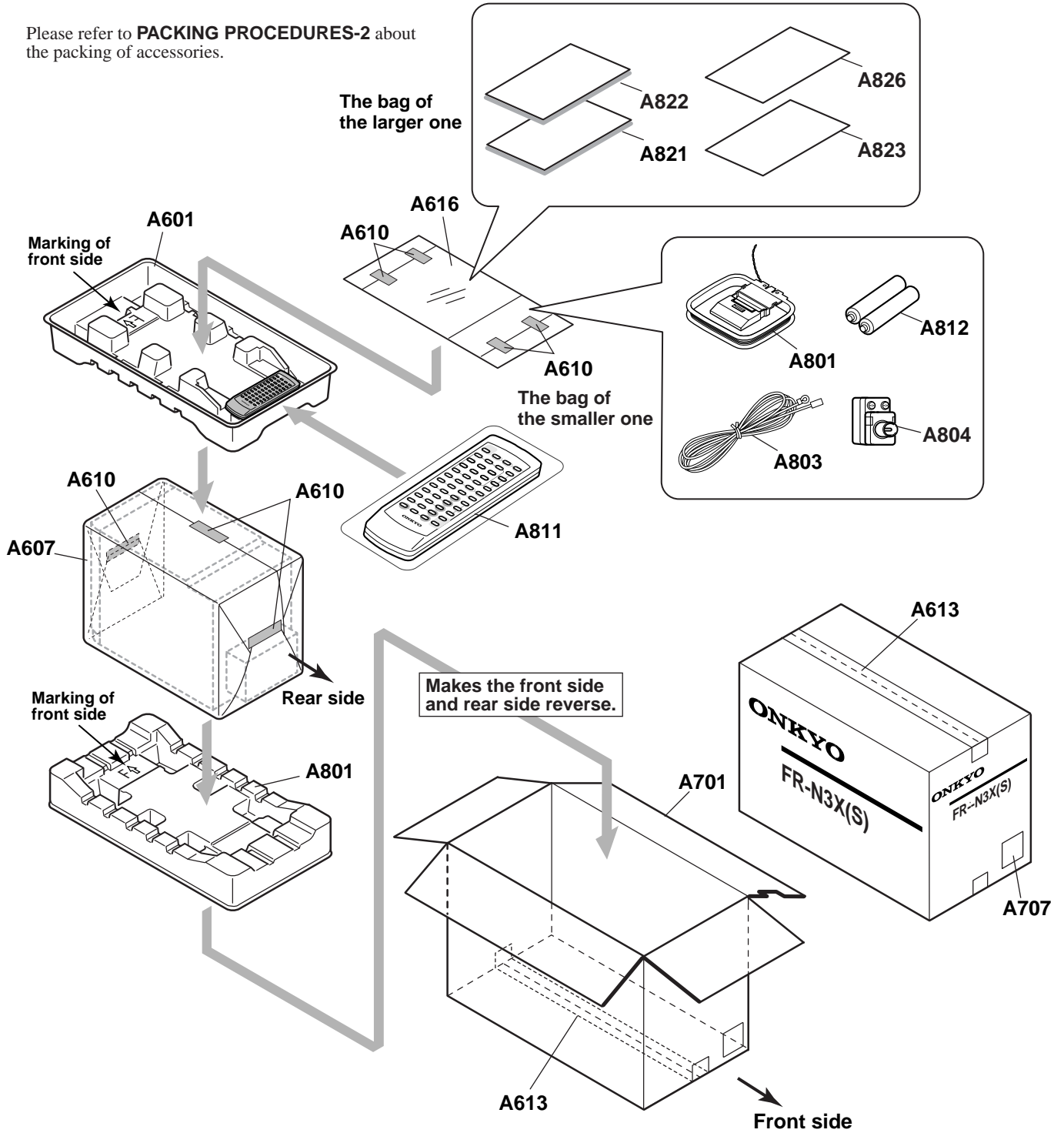

PACKING VIEWS-2

ENCLOSURE METHOD OF ACCESSORIES

The work method is the same although a photograph of other models.

- 1** Put remote controller into the portion of the hollow of the pad.

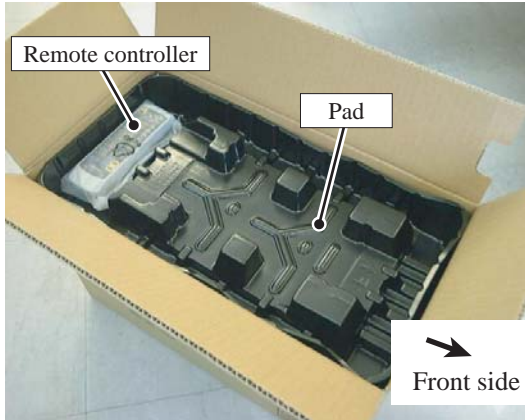

- 3** Turns up the direction containing the instruction manual.

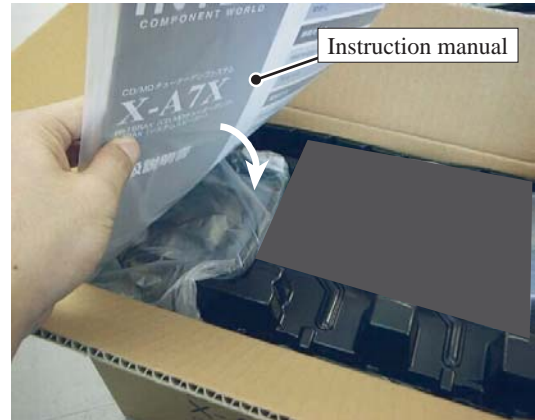

- 2** Puts the direction containing AM antenna into the portion of the hollow of a pad.



- 4** Complete



Front side

Front side

FR-N3X

EXPLODED VIEW PART LIST

[NOTES]

<DT> : Taiwanese model only

<GT> : Aisian model only

<GQ> : Hong kong model only

<GR> : Chinese model only

<p>NOTE : THE COMPONENTS IDENTIFIED BY THE MARK ! ARE CRITICAL FOR RISK OF FIRE AND ELECTRIC SHOCK. REPLACE ONLY WITH PART NUMBER SPECIFIED.</p>

	REF NO.	PART NAME	DESCRIPTION	PART NO.	NOTES
Exploded view	A001	F BRACKET	---	27111285	N
Exploded view	A013	CHASSIS	---	27100423B	
Exploded view	A016	SCREW	4TTC+6C(BC)	830440069	
Exploded view	A019	HOLDER	(CD)	27191171A	
Exploded view	A022	SCREW	3TTB+16S(BC)	838430167	
Exploded view	A031	PLATE	(S)	27262600	
Exploded view	A034	HEAT SINK	173	27160513	
Exploded view	A037	SCREW	3SMS8W.SW+14B(BC)	801433	
Exploded view	A040	SCREW	3TTB+8B	838130088	
Exploded view	A041	SCREW	3TTB+8B(BC)	838430088	
Exploded view	A042	BUSHING	S-RELIEF #2271	27300750	!
Exploded view	A043	COVER	(HT)	28184584	
Exploded view	A049	BRACKET	(MD)	27130885	
Exploded view	A052	SCREW	3TTB+10S(BC)	838430107	
Exploded view	A058	BRACKET	(CD)	27130887	
Exploded view	A067	CLIP	CS-1U	27255004	
Exploded view	A070	SCREW	3TTW+8B(BC)	831430088	
Exploded view	A073	COVER	---	28184842A	
Exploded view	A079	COVER	(TOP)	28184843	
Exploded view	A082	SCREW	3TTB+8B(UN)	838930088	
Exploded view	A085	DOOR	(CD)	28148508	
Exploded view	A089	F PANEL	---	27212427	UDT, UGR, UGT
Exploded view	A090	FACET	(S)	28198939	
Exploded view	A097	CLEAR PLT	---	28191968	
Exploded view	A098	GUIDE	(SB)	27268059	
Exploded view	A099	CLEAR PLT	(RE)	28191941	
Exploded view	A100	KNOB	(VOL)	28326015	
Exploded view	A101	REAR PANEL	---	27123005A	UDT, UGR, UGT
Exploded view	A103	KNOB	(JOG)	28325817A	
Exploded view	A106	CUSHION	---	28141489	
Exploded view	A107	SPEC LABEL	(TEIKAKU)	29363130	UDT
Exploded view	A107	SPEC LABEL	(TEIKAKU)	29363132	UGR
Exploded view	A107	SPEC LABEL	(TEIKAKU)	29363131	UGT
Exploded view	A109	LABEL	RG-309250-1	29362285	UDT, UGR, UGT
Exploded view	F901	FUSE	1.6A-UL/T-237	252158	! UDT
Exploded view	F901	FUSE	0.4A-SE-EAWK FUSE	252083	! UGR,UGT
Exploded view	P101	FFC	NCFC4-160191	2044160191	
Exploded view	P102	FFC	NCFC2-162012	2042162012	
Exploded view	P201	SOCKET AS	NSAS-12P0655	2002391215	
Exploded view	P202	FFC	NCFC7-061522	2047061522	
Exploded view	P351	FFC	NCFC5-291012	2045291012	
Exploded view	P451	FFC	NCFC7-151512	2047151512	
Exploded view	P901	AC CORD	AS-UC-2	253330MIL or	! UDT
Exploded view	P901 or	AC CORD	AS-UC-2	253331HDK	! UDT
Exploded view	P901	AC CORD	AS-CCEE	253337HIT or	! UGR
Exploded view	P901 or	AC CORD	AS-CCEE	253338VOL	! UGR
Exploded view	P901	AC CORD	AS-CEE	253334HRK or	! UGT

Exploded view	P901 or	AC CORD	AS-CEE	253313HRK	! UGT
[NOTES] When replacement of the transistor Q557-Q560, made from the same beta group (HFE) as the original type.					
Exploded view	Q557	TR	2SC3851-O or	2203383 or	
Exploded view	Q557 or	TR	2SC3851-Y	2203384	
Exploded view	Q557 or	TR	2SC3851-G	2203385	
Exploded view	Q558	TR	2SC3851-O or	2203383 or	
Exploded view	Q558 or	TR	2SC3851-Y	2203384	
Exploded view	Q558 or	TR	2SC3851-G	2203385	
Exploded view	Q559	TR	2SA1488-O or	2203393 or	
Exploded view	Q559 or	TR	2SA1488-Y	2203394	
Exploded view	Q559 or	TR	2SA1488-G	2203395	
Exploded view	Q560	TR	2SA1488-O or	2203393 or	
Exploded view	Q560 or	TR	2SA1488-Y	2203394	
Exploded view	Q560 or	TR	2SA1488-G	2203395	
Exploded view	T901	P TRANS	NPT-1447D	2301630	UDT
Exploded view	T901	P TRANS	NPT-1447G	2301631	UGR, UGT
Exploded view	Z001	MD MECHA	KMK-260EEO	24650036	
Exploded view	Z002	DOOR	.	24611666	
Exploded view	Z003	SPRING	(DOOR)RG417686-1	24605828	
Exploded view	Z004	SHAFT	(DOOR)RG417685-1	24604139A	
Exploded view	U1	PREAMPLIFIER PC BOARD	NAAF-7585-1B	1A945585-1B	UDT
Exploded view	U1	PREAMPLIFIER PC BOARD	NAAF-7585-1C	1A945585-1C	UGR, UGT, UGQ
Exploded view	U2	DISPLAY PC BOARD	NADIS-7586-1B	1A945586-1B	UDT
Exploded view	U2	DISPLAY PC BOARD	NADIS-7586-1C	1A945586-1C	UGR, UGT, UGQ
Exploded view	U3	OPERATION SWITCH PC BOARD	NASW-7587-1B	1A945587-1B	UDT
Exploded view	U3	OPERATION SWITCH PC BOARD	NASW-7587-1C	1A945587-1C	UGR, UGT, UGQ
Exploded view	U4	DIGITAL OUTPUT TERMINAL PC BOARD	NAETC-7588-1B	1A945588-1B	UDT
Exploded view	U4	DIGITAL OUTPUT TERMINAL PC BOARD	NAETC-7588-1C	1A945588-1C	UGR, UGT, UGQ
Exploded view	U5	HEAD PHONE PC BOARD	NAETC-7589-1B	1A945589-1B	UDT
Exploded view	U5	HEAD PHONE PC BOARD	NAETC-7589-1C	1A945589-1C	UGR, UGT, UGQ
Exploded view	U6	POWER SUPPLY PC BOARD	NAPS-7553-2B	1A945553-2B	UDT
Exploded view	U6	POWER SUPPLY PC BOARD	NAPS-7553-2C	1A945553-2C	UGR, UGT, UGQ
Exploded view	U7	POWER AMPLIFIER PC BOARD	NAAF-7554-2B	1A945554-2B	UDT
Exploded view	U7	POWER AMPLIFIER PC BOARD	NAAF-7554-2C	1A945554-2C	UGR, UGT, UGQ
Exploded view	U8	SPEAKER TERMINAL PC BOARD	NAETC-7555-2B	1A945555-2B	UDT
Exploded view	U8	SPEAKER TERMINAL PC BOARD	NAETC-7555-2C	1A945555-2C	UGR, UGT, UGQ
Exploded view	U9	CD and MICROPROCESSOR PC BOARD	NADG-7557-2B	1A945557-2B	UDT
Exploded view	U9	CD and MICROPROCESSOR PC BOARD	NADG-7557-2C	1A945557-2C	UGR, UGT, UGQ
Exploded view	U10	CONNECTOR PC BOARD	NAETC-7590-2B	1A945590-2B	UDT
Exploded view	U10	CONNECTOR PC BOARD	NAETC-7590-2C	1A945590-2C	UGR, UGT, UGQ
Exploded view	U11	TUNER UNIT	TFCE1E512A	240135	UDT,UGR, UGT

FR-N3X**EXPLODED VIEWS OF MECHANISM (CD)**

	REF NO.	PART NAME	DESCRIPTION	PART NO.	NOTES
CD	Z06	DT1400, Loading mechanism	---	24800051	
CD	Z07	KSM-213CCM, Drive unit	---	24800017	
CD	Z08	Insulator, (C)	---	24818051	
CD	Z09	Insulator, (D)	---	24818052	
CD	Z10	Screw, (A)	---	801589	
CD	Z11	Screw, (B)	---	801590	
CD	Z12	Washer, (C)	---	24834041	

CD TRAY LOADING MECHANISM : DT1400

	REF NO.	PART NAME	DESCRIPTION	PART NO.	NOTES
CD	B13	Loading motor ass'y	---	70300470B	
CD	B16	Gear pulley	---	70333502B	
CD	B17	Drive belt	---	70342118	
CD	B18	Gear, Connector	---	70333503C	
CD	B19	Gear, Loading	---	70333504E	
CD	B21	Table disk-C	---	70366206	
CD	B22	Clamper ass'y-C	---	70300654	
CD	B24	Spring tray, Bias-C	---	70356536	

CD DRAIVE UNIT : KSM-213CCM

	REF NO.	PART NAME	DESCRIPTION	PART NO.	NOTES
CD	51	Motor chassis ass'y	---	X-2625-877-1	
CD	52	Motor gear ass'y	---	X2625-769-1	
CD	53	Sled shaft	---	2626-908-01	
CD	54	Gear (A) (S)	---	24810023	
CD	55	P2 × 3, Screw	---	7621-255-15	
CD	56	Leaf switch	---	24840008	
CD	57	Motor PC board	---	1639-678-12	
CD	58	Connector 6pin	---	1-564-722-11	
CD	61	KSS-213C, Pickup	---	8848-483-05	

FR-N3X**EXPLODED VIEWS OF MECHANISM (MD)**

The mechanical parts with no part number in the exploded views are not supplied.

MD MECHANISM : KMK-260EEO

	REF NO.	PART NAME	DESCRIPTION	PART NO.	NOTES
MD	1	Motor Plate ass'y	---	---	
MD	2	Screw +PTT2.6 × 5 (S)	---	7685-791-01	
MD	3	L-SW Mount 2	---	---	
MD	4	Flexible flat cable (5 core)	---	1792-100-31	
MD	5	Gear (Relay B)	---	2646-555-02	
MD	6	Gear (Relay A)	---	2646-554-01	
MD	7	Frame ass'y, slot	---	X2646-726-1	
MD	8	Spring(Slot arm), tension coil	---	2646-563-01	
MD	9	Slot Arm	---	2646-556-01	
MD	10	Flame ass'y, Road	---	---	
MD	11	Insulator	---	2646-548-01	
MD	13	Screw, Step	---	2647-337-01	
MD	14	Frame, Slide	---	---	
MD	15	Arm, head	---	2646-559-02	
MD	16	Spring, Tension coil	---	2646-562-01	
MD	17	Spring, SP Tension	---	2646-561-01	
MD	18	Cam, Mode	---	2646-560-02	
MD	20	Grip (+P1.7 × 2.5 Type2)	---	2627-529-01	
MD	21	MD over write head	---	8620-021-71	
MD	23	MD mount PC board	---	---	
MD	24	Screw +PTT2.6 × 5 (S)	---	7685-791-09	
MD	26	Spring (Door arm), tension coil	---	2646-545-01	
MD	27	Case (lower)	---	---	
MD	30	Loading motor ass'y	---	X2626-328-1	
MD	31	Precision screw (+P1.7 × 1.8 Type3)	---	7627-852-38	
MD	32	Screw +PTT2 × 3 (S)	---	7685-780-01	
MD	33	Loading ass'y	---	---	

MD	34	Case (Upper)	---	---
MD	35	Screw +P2.6×4	---	7621-259-25
MD				
MD	51	Pan tapping screw (M1.4 × 3.5)	---	3348-998-51
MD	52	Plate (M), Pre-load	---	2167-550-01
MD	53	Wire, SL motor lead	---	---
MD	54	Wire, SL motor lead	---	---
MD	55	Sled motor ass'y	---	X2162-145-1
MD	56	Gear (MD)	---	2646-571-01
MD	57	Plate (M), main shaft fixed	---	2167-551-01
MD	58	Screw ass'y lead	---	X2162-144-1
MD	59	Screw (B1.7 x 4)	---	2646-358-11
MD	60	Spinlde motor ass'y	---	X2162-143-1 *
MD	61	D-SW mount 2	---	---
MD	62	Chassis (M), mechanical	---	---
MD	63	Shaft (M), guide	---	2167-819-01
MD	64	Spring, rack	---	2647-338-01
MD	65	Grip (1.7 × 2.5 type 2)	---	2627-529-01
MD	66	Optical pickup, KMS-260E	---	8-583-079-06
MD	67	Deck ass'y, mechanical	---	---
MD	68	OP Flexible flat cable	---	1669-180-11
MD	69	Flexible flat cable (7 core)	---	1783-387-11

MD

* [NOTES] When you need exchange of the Spinlde motor ass'y, please exchange Mechanism ASSY and correspond.

MD MOUNT (PCB ASSY)

The mechanical parts with no part number in the exploded views are not supplied.

REF NO.	PART NAME	DESCRIPTION	PART NO.	NOTES
MD	IC101	CXA2523AR	---	8752-080-95
MD	IC102	90M, Crystal oscillator	---	1781-569-21
MD	IC103	FMW1-T-148	---	8729-903-10
MD	IC104	RH5RZ33CA-T1	---	6702-431-01
MD	IC105	TK71533ASCL	---	8759-832-31
MD	IC121	CXD2664R	---	8752-414-89
MD	IC125	MSM51V4400E-70TS-K	---	8759-671-27
MD	IC152	BA5984FP-E2	---	8759-574-24
MD	IC171	BR24C02F-WE2	---	8759-640-39
MD	IC181	TC74ACT02FT(EL)	---	8759-523-35
MD	IC201	CXP740010-063R	---	8752-932-73
MD	IC301	AK4552VT-E2	---	6700-563-01
MD	Q101	DTA144EUA-T106	---	8729-028-91
MD	Q102	2SA1576A-T106-QR	---	8729-026-52
MD	Q103	DTC114EUA-T106	---	8729-028-96
MD	Q104	DTC114EUA-T106	---	8729-028-96
MD	Q162	2SB798-T1DK	---	8729-101-07
MD	Q163	DTA144EUA-T106	---	8729-028-91
MD	Q181	2SJ278MYTR	---	8729-018-75
MD	Q182	2SK1764KYTR	---	8729-017-66
MD	D101	1SS355	---	223269R2
MD	D181	F1J6TP	---	8719-046-87
MD	D183	F1J6TP	---	8719-046-87
MD	X201	12M, Ceramic oscillator	---	1767-179-31
MD	CN101	Connector, FFC/FPC (21P)	---	1691-385-21
MD	CN102	Connector, FFC/FPC (29P)	---	1778-461-11
MD	CN103	Connector, FFC/FPC (13P)	---	1793-793-21

MD	CN104	Connector, FFC/FPC (4P)	---	1778-283-11
MD	CN105	Connector, FFC/FPC ((7P)	---	1779-345-11
MD	CN106	Connector, FFC/FPC (5P)	---	1779-353-21
MD	SW1--SW	Push switch (1key)	---	1771-092-21
MD	SW5	2pin push switch (2key)	---	1771-327-11
MD	---	L-SW mount 2, PC board	---	---
MD	---	D-SW mount 2, pC board	---	---

PRINTED CIRCUIT BOARD PARTS LIST**FR-N3X**

<DT> : Taiwanese model only

<GT> : Aisian model only

<GK> : Korean model only

<GR> : Chinese model only

NOTE : THE COMPONENTS IDENTIFIED BY THE MARK ! ARE
CRITICAL FOR RISK OF FIRE AND ELECTRIC SHOCK.
REPLACE ONLY WITH PART NUMBER SPECIFIED.

U1 PREAMPLIFIER PC BOARD (NAAF-7585-1B/1C)

REF NO.	PART NAME	DESCRIPTION	PART NO.	NOTES
U1	Q301	IC	NJM4565M-D	22241383R2
U1	Q321	IC	NJM2100M	22240608R1
U1	Q451	IC	M62433FP	22241807R3
U1	Q941	IC(REGULATOR)	NJM78M06FA	222780065JRC
U1	Q941A	HEAT SINK	RAD-157	27160491
U1	Q941B	SCREW	3P+10FN(BC)	82143010
U1	Q942	IC(REGULATOR)	NJM79M06FA	222790065JRC
U1	Q942A	HEAT SINK	RAD-157	27160491
U1	Q942B	SCREW	3P+10FN(BC)	82143010
U1	Q943	IC(REGULATOR)	MPC29M12HF	22278012ENE
U1	Q944	IC(REGULATOR)	NJM78L05A	222780053JRC
U1	Q303	TR	2SD1468S-R	2215024 or
U1	Q303 or	TR	2SD1468S-S	2215025
U1	Q304	TR	2SD1468S-R	2215024 or
U1	Q304 or	TR	2SD1468S-S	2215025
U1	Q323	TR	2SD1468S-R	2215024 or
U1	Q323 or	TR	2SD1468S-S	2215025
U1	Q324	TR	2SD1468S-R	2215024 or
U1	Q324 or	TR	2SD1468S-S	2215025
U1	Q453	TR	RN1441	2215410R2
U1	Q454	TR	RN1441	2215410R2
U1	Q493	TR	RN2402	2214530R2
U1	Q494	TR	2SA1162-GR	2214375R2
U1	Q495	TR	2SC2712-GR	2213145R2
U1	D491	C-DIODE	1SS355	223269R2 or
U1	D491 or	C-DIODE	1SS352	223234R2
U1	D492	C-DIODE	1SS355	223269R2 or
U1	D492 or	C-DIODE	1SS352	223234R2
U1	D941	C-DIODE	1SS355	223269R2 or
U1	D941 or	C-DIODE	1SS352	223234R2
U1	D942	C-DIODE	1SS355	223269R2 or
U1	D942 or	C-DIODE	1SS352	223234R2
U1	D943	C-DIODE	1SS355	223269R2 or
U1	D943 or	C-DIODE	1SS352	223234R2
U1	D944	C-DIODE	1SS355	223269R2 or
U1	D944 or	C-DIODE	1SS352	223234R2
U1	C252	VR C	CE04W50V-3.3M(VR)	394680337
U1	C254	VR C	CE04W50V-3.3M(VR)	394680337

U1	C301	MY C	MY92-50V-102J	371121024	
U1	C302	MY C	MY92-50V-102J	371121024	
U1	C303	MY C	MY92-50V-222J	371122224	
U1	C304	MY C	MY92-50V-222J	371122224	
U1	C305	VX C	CE04W16V-10M(VX)	393341007	
U1	C306	VX C	CE04W16V-10M(VX)	393341007	
U1	C309	VR C	CE04W16V-220M(VR)	394642217	
U1	C310	VR C	CE04W16V-220M(VR)	394642217	
U1	C321	VX C	CE04W50V-2.2M(VX)	393380227	
U1	C322	VX C	CE04W50V-2.2M(VX)	393380227	
U1	C323	VX C	CE04W16V-22M(VX)	393342207	
U1	C324	VX C	CE04W16V-22M(VX)	393342207	
U1	C327	VX C	CE04W16V-10M(VX)	393341007	
U1	C328	VX C	CE04W16V-10M(VX)	393341007	
U1	C330	VR C	CE04W6.3V-220M(VR)	394622217	
U1	C431	VR C	CE04W16V-220M(VR)	394642217	
U1	C432	VR C	CE04W16V-220M(VR)	394642217	
U1	C433	TF C	ECQ-V50V-473J	374724734	
U1	C434	TF C	ECQ-V50V-473J	374724734	
U1	C465	VR C	CE04W50V-0.33M(VR)	394683397	
U1	C466	VR C	CE04W50V-0.33M(VR)	394683397	
U1	C467	MY C	MY92-50V-103J	371121034	
U1	C468	MY C	MY92-50V-103J	371121034	
U1	C471	MY C	MY92-50V-272J	371122724	
U1	C472	MY C	MY92-50V-272J	371122724	
U1	C473	VX C	CE04W50V-10M(VX)	393381007	
U1	C474	VX C	CE04W50V-10M(VX)	393381007	
U1	C477	VX C	CE04W50V-10M(VX)	393381007	
U1	C479	MMT C	MMT50V-154J	375521544	
U1	C480	MMT C	MMT50V-154J	375521544	
U1	C481	VX C	CE04W16V-47M(VX)	393344707	
U1	C482	VX C	CE04W16V-47M(VX)	393344707	
U1	C483	VX C	CE04W16V-47M(VX)	393344707	
U1	C484	VX C	CE04W16V-47M(VX)	393344707	
U1	C491	VR C	CE04W50V-3.3M(VR)	394680337	
U1	C492	VR C	CE04W6.3V-100M(VR)	394621017	
U1	C494	MY C	MY92-50V-104J	371121044	
U1	C941	VR C	CE04W35V-220M(VR)	394662217	
U1	C942	VR C	CE04W35V-220M(VR)	394662217	
U1	C945	VR C	CE04W50V-1.0M(VR)	394680107	
U1	C946	VR C	CE04W50V-1.0M(VR)	394680107	
U1	C948	VR C	CE04W16V-100M(VR)	394641017	
U1	C949	VR C	CE04W16V-47M(VR)	394644707	
U1	R443	METAL O R	RS1/2WBJ-22	443522204	
U1	R444	METAL O R	RS1/2WBJ-22	443522204	
U1	R445	METAL O R	RS1/2WBJ-22	443522204	
U1	R446	METAL O R	RS1/2WBJ-22	443522204	
U1	R943	METAL R	RNU1/4WJ-47	4500187	
U1	R944	METAL R	RNU1/4WJ-47	4500187	
U1	P381	JACK	YKB21-5130	25045387	
U1	P401	PIN JACK	NPJ-6PDBL159	25045300 or	RI
U1	P401 or	PIN JACK	NPJ-6PDRW386	25045571	
U1	P501A	PLUG	NPLG-7P659	25055703	
U1	P903A	PLUG	NPLG-6P658	25055702	
U1	P151B	SOCKET	NSCT-10P2580	25052684	

U1	P451A	SOCKET	NSCT-15P2108	25052211
U1	P702B	SOCKET	NSCT-20P2585	25052689
U1	E401	TRM	NTM-1P233(M1969)	25060302
---	E861	CUSHION	.	28141500
---	E862	CUSHION	.	28141500

U2 DISPLAY PC BOARD (NADIS-7586-1A)

REF NO.	PART NAME	DESCRIPTION	PART NO.	NOTES	
U2	Q802	FL TUBE	HNA-14MS08T	212231	
U2	Q801	IC	MPU/80232GC-U/U- 8BT	22241814R3	SUBMICROPROCESSOR
U2	Q803	TR	2SC2712-GR	2213145R2	
U2	Q804	TR	2SC2712-GR	2213145R2	
U2	Q805	TR	DTC114YKA	2216470R2 or	
U2	Q805 or	TR	RN1407	2216260R2	
U2	D801	ZENER D	UDZS5.6B	224550560R2 or	
U2	D801 or	ZENER D	RD5.6SB2	224370562R2	
U2	D802	LED	SLR-342VR T-32	225412 or	STANDBY/ON
U2	D802 or	LED	SLR-343VRT32	225414	
U2	X801	CERA LOCK	CSTS0500MG06	3010343	
U2	C801	ELECT C	CE04W16V-10M	355741009	
U2	C819	ELECT C	CE04W50V-2.2M	355780229	
U2	S801	R ENCODE	EC12E2470802	25065630	VOLUME
U2	S802	R ENCODE	EC12E2424404	25065631	MULTI JOG
U2	S803	PUSH SW	NPS-111-S662	25035699	
U2	S804	PUSH SW	NPS-111-S662	25035699	
U2	S805	PUSH SW	NPS-111-S662	25035699	
U2	S806	PUSH SW	NPS-111-S662	25035699	
U2	S807	PUSH SW	NPS-111-S662	25035699	
U2	S808	PUSH SW	NPS-111-S662	25035699	
U2	S809	PUSH SW	NPS-111-S662	25035699	
U2	S810	PUSH SW	NPS-111-S662	25035699	
U2	S811	PUSH SW	NPS-111-S662	25035699	
U2	S812	PUSH SW	NPS-111-S662	25035699	
U2	S813	PUSH SW	NPS-111-S662	25035699	
U2	S814	PUSH SW	NPS-111-S662	25035699	
U2	S815	PUSH SW	NPS-111-S662	25035699	
U2	S816	PUSH SW	NPS-111-S662	25035699	
U2	P801	SOCKET AS	NSAS-22P1011	2002E392225	
U2	P803A	SOCKET AS	NSAS-8P1012	2009990721	

U3 OPERATION SWITCH PC BOARD (NASW-7587-1B/1C)

REF NO.	PART NAME	DESCRIPTION	PART NO.	NOTES
U3	U851	REMO SENS	SPS-450-1E	241340 or
U3	U851 or	REMO SENS	SPS-450-1-EP1	241344
U3	C852	ELECT C	CE04W6.3V-47M	355724709
U3	S851	PUSH SW	NPS-111-S662	25035699
U3	S852	PUSH SW	NPS-111-S662	25035699
U3	S853	PUSH SW	NPS-111-S662	25035699
U3	S854	PUSH SW	NPS-111-S662	25035699
U3	S855	PUSH SW	NPS-111-S662	25035699
U3	S856	PUSH SW	NPS-111-S662	25035699
U3	P803B	PLUG	NPLG-4P351	25055368

U4 DIGITAL OUTPUT TERMINAL PC BOARD (NAETC-7588-1B/1C)

	REF NO.	PART NAME	DESCRIPTION	PART NO.	NOTES
U4	Q207	PHT CP	GP1FA550TZ	24120082 or	OPTICAL OUTPUT
U4	Q207 or	PHT PARTS	TOTX178A	24120031	
U4	L201	CHOKE COIL	BLM21B222SPT	230921R2	
U4	C216	VR C	CE04W16V-10M(VR)	394641007	
U4	C478	VX C	CE04W50V-10M(VX)	393381007	
U4	P203B	SOCKET AS	NSAS-6P1015	2009990724	

U5 HEADPHONE PC BOARD (NAETC-7589-1B/1C)

	REF NO.	PART NAME	DESCRIPTION	PART NO.	NOTES
U6	D902	C-DIODE	1SS355	223269R2	
U5	JL501A	WIRE HOL	NSCT-5P876	25051089	
U5	P504	JACK	LGT1516-0101	25045396	PHONES

U6 POWER SUPPLY PC BOARD (NAPS-7553-2B/2C)

	REF NO.	PART NAME	DESCRIPTION	PART NO.	NOTES
U6	Q923	IC(REGULATOR)	MPC2905HF	22278005DNE	
U6	Q923A	HEAT SINK	RAD-172	27160512	
U6	Q923B	SCREW	3P+10FN(BC)	82143010	
U6	Q924	IC(REGULATOR)	MPC2905HF	22278005DNE	
U6	Q924B	SCREW	3P+10FN(BC)	82143010	
U6	Q901	TR	DTC123JKA	2216690R2	
U6	Q921	TR	2SB1068-K	2212853	
U6	Q922	TR	DTC114YKA	2216470R2 or	
U6	Q922 or	TR	RN1407	2216260R2	
U6	Q931	TR	2SA1015-GR	2211455	
U6	D503	ZENER D	UDZS5.6B	224550560R2 or	
U6	D503 or	ZENER D	RD5.6SB2	224370562R2	
U6	D504	ZENER D	UDZS5.6B	224550560R2 or	
U6	D504 or	ZENER D	RD5.6SB2	224370562R2	
U6	D901	DIODE	S1NB60-4062	22380318R2 or	
U6	D902 or	C-DIODE	1SS352	223234R2	
U6	D903	C-DIODE	1SS355	223269R2 or	
U6	D903 or	C-DIODE	1SS352	223234R2	
U6	D904	ZENER D	UDZS5.1B	224550510R2 or	
U6	D904 or	ZENER D	RD5.1SB2	224370512R2	
U6	D905	C-DIODE	1SS355	223269R2 or	
U6	D905 or	C-DIODE	1SS352	223234R2	
U6	D921	DIODE	GSIB460	22380316F or	
U6	D921 or	DIODE	D3SBA20	22380271F	
U6	D922	DIODE	GSIB460	22380316F or	
U6	D922 or	DIODE	D3SBA20	22380271F	
U6	D931	DIODE	RL1N4003	22380260 or	
U6	D931 or	DIODE	1SR139-100	22380032 or	
U6	D931 or	DIODE	GP104003E	22380035	
U6	D932	ZENER D	RD27SB	224372700R2 or	
U6	D932 or	ZENER D	UDZS27B	224552700R2	
U6	L901	CHOKE COIL	NCH-3581	231301	!
U6	T902	P TRANS	NPT-1398D	2301464	! DT
U6	T902	P TRANS	NPT-1398G	2301465	! GT,GR,GQ
U6	C901	IS C	DE1307E472M-KH	3300030	!
U6	C902	IS C	DE1307E472M-KH	3300030	!
U6	C903	IS C	RE275V-103M	3500196S or	
U6	C903 or	IS C	MKP R46 103M	3500202S	
U6	C905	VR C	CE04W16V-1000M(VR)	394641027	

U6	C906	VR C	CE04W16V-10M(VR)	394641007	
U6	C907	MMT C	MMT50V-334J	375523344	
U6	C921	ELECT C	CE04W10V-220M(VR)	3504348	
U6	C923	VR C	CE04W16V-10M(VR)	394641007	
U6	C925	VR C	CE04W16V-10M(VR)	394641007	
U6	C927	TF C	ECQ-V50V-334J	374723344	
U6	C931	VR C	CE04W50V-220M(VR)	394682217	
U6	C934	VR C	CE04W50V-10M(VR)	394681007	
U6	R907	METAL R	RNU1/2WCJ-1	453530104	
U6	R921	METAL R	RNU1/2WCJ-0.1	453531094	
U6	R922	METAL R	RNU1/2WCJ-0.1	453531094	
U6	R931	METAL R	RNU1/2WCJ-2.2	453530224	
U6	R932	METAL O R	RS1/2WBJ-27	443522704	
U6	JL352A	WIRE HOL	NSCT-5P896	25051109	
U6	JL703A	WIRE HOL	NSCT-7P878	25051091	
U6	JL901A	SOCKET	NSCT-4P96	25050268	
U6	P907	PLUG	NPLG-2P631	25055675	!
U6	F901A	FUSE HOL	NSCT-1P2031	25052133	
U6	F901B	FUSE HOL	NSCT-1P2031	25052133	
U6	F901C	LABEL	T400MAL250V	29361919	GT,GR,GQ

U7 POWER AMPLIFIER PC BOARD (NAPS-7554-2B/2C)

REF NO.	PART NAME	DESCRIPTION	PART NO.	NOTES
U7	Q491	TR	RN1441	2215410R2
U7	Q492	TR	RN1441	2215410R2
U7	Q501	TR	2SC1622A(D17)	2216153R2 or
U7	Q501 or	TR	2SC1622A(D18)	2216154R2
U7	Q502	TR	2SC1622A(D17)	2216153R2 or
U7	Q502 or	TR	2SC1622A(D18)	2216154R2
U7	Q503	TR	2SC1622A(D17)	2216153R2 or
U7	Q503 or	TR	2SC1622A(D18)	2216154R2
U7	Q504	TR	2SC1622A(D17)	2216153R2 or
U7	Q504 or	TR	2SC1622A(D18)	2216154R2
U7	Q505	TR	2SC2712-GR	2213145R2
U7	Q506	TR	2SC2712-GR	2213145R2
U7	Q509	TR	2SA1015-GR	2211455
U7	Q510	TR	2SA1015-GR	2211455
U7	Q511	TR	2SA1015-GR	2211455
U7	Q511	TR	2SA1015-GR	2211455
U7	Q515	TR	2SA1015-GR	2211455
U7	Q516	TR	2SA1015-GR	2211455
U7	Q517	TR	2SC1815-GR	2211255
U7	Q518	TR	2SC1815-GR	2211255
U7	Q519	TR	2SC1815-GR	2211255
U7	Q520	TR	2SC1815-GR	2211255
U7	Q551	TR	2SC2712-GR	2213145R2
U7	Q552	TR	2SC2712-GR	2213145R2
U7	Q553	TR	2SC2235-O	2211653 or
U7	Q553 or	TR	2SC2235-Y	2211654
U7	Q554	TR	2SC2235-O	2211653 or
U7	Q554 or	TR	2SC2235-Y	2211654
U7	Q555	TR	2SA965-O	2211643 or
U7	Q555 or	TR	2SA965-Y	2211644
U7	Q556	TR	2SA965-O	2211643 or
U7	Q556 or	TR	2SA965-Y	2211644

U7	Q561	TR	2SA1162-GR	2214375R2	
U7	Q562	TR	2SA1162-GR	2214375R2	
U7	Q581	TR	2SC1740S-R	2213284	
U7	Q582	TR	2SC1740S-R	2213284	
U7	Q583	TR	2SA933S-R	2213354	
U7	D501	C-DIODE	1SS355	223269R2 or	
U7	D501 or	C-DIODE	1SS352	223234R2	
U7	D502	C-DIODE	1SS355	223269R2 or	
U7	D502 or	C-DIODE	1SS352	223234R2	
U7	D581	ZENER D	UDZS5.1B	224550510R2 or	
U7	D581 or	ZENER D	RD5.1SB2	224370512R2	
U7	D911	DIODE	GSIB460	22380316F or	
U7	D911 or	DIODE	D3SBA20	22380271F	
U7	C501	VX C	CE04W35V-22M(VX)	393362207	
U7	C502	VX C	CE04W35V-22M(VX)	393362207	
U7	C505	VR C	CE04W16V-22M(VR)	394642207	
U7	C506	VR C	CE04W16V-22M(VR)	394642207	
U7	C509	VX C	CE04W6.3V-220M(VX)	393322217	
U7	C510	VX C	CE04W6.3V-220M(VX)	393322217	
U7	C513	MMT C	MMT50V-104J	375521044	
U7	C514	MMT C	MMT50V-104J	375521044	
U7	C517	VX C	CE04W16V-10M(VX)	393341007	
U7	C518	VX C	CE04W16V-10M(VX)	393341007	
U7	C541	VR C	CE04W35V-100M(VR)	394661017	
U7	C542	VR C	CE04W35V-220M(VR)	394662217	
U7	C551	VX C	CE04W50V-10M(VX)	393381007	
U7	C552	VX C	CE04W50V-10M(VX)	393381007	
U7	C553	MY C	MY92-50V-473J	371124734	
U7	C554	MY C	MY92-50V-473J	371124734	
U7	C583	VR C	CE04W50V-1.0M(VR)	394680107	
U7	C911	TF C	ECQ-V50V-334J	374723344	
U7	C912	TF C	ECQ-V50V-334J	374723344	
U7	C913	VX C	CE04W25V-3300M(VX)	393353327S	
U7	C914	VX C	CE04W25V-3300M(VX)	393353327S	
U7	R519	METAL O R	RS1/2WBJ-39	443523904	
U7	R520	METAL O R	RS1/2WBJ-39	443523904	
U7	R521	METAL O R	RS1/2WBJ-39	443523904	
U7	R522	METAL O R	RS1/2WBJ-39	443523904	
U7	R533	METAL O R	RS1/2WBJ-33	443523304	
U7	R534	METAL O R	RS1/2WBJ-33	443523304	
U7	R535	METAL O R	RS1/2WBJ-39	443523904	
U7	R536	METAL O R	RS1/2WBJ-39	443523904	
U7	R541	METAL O R	RS1/2WBJ-22	443522204	
U7	R542	METAL O R	RS1/2WBJ-22	443522204	
U7	R551	C-CARBON R	RN72K1J-152FE	435031522R1	Tlerance +/-1% class
U7	R552	C-CARBON R	RN72K1J-152FE	435031522R1	Tlerance +/-1% class
U7	R553	C-CARBON R	RN72K1J-681FE	435036812R1	Tlerance +/-1% class
U7	R554	C-CARBON R	RN72K1J-681FE	435036812R1	Tlerance +/-1% class
U7	R555	C-CARBON R	RN72K1J-472FE	435034722R1	Tlerance +/-1% class
U7	R556	C-CARBON R	RN72K1J-392FE	435033922R1	Tlerance +/-1% class
U7	R557	METAL O R	RS1/2WBJ-82	443528204	
U7	R558	METAL O R	RS1/2WBJ-82	443528204	
U7	R559	METAL R	RNU2WCJ-0.22	452732294F	
U7	R560	METAL R	RNU2WCJ-0.22	452732294F	
U7	R561	METAL R	RNU2WCJ-0.22	452732294F	

U7	R562	METAL R	RNU2WCJ-0.22	452732294F	
U7	R563	METAL R	RNU1/2WCJ-8.2	453530824	
U7	R564	METAL R	RNU1/2WCJ-8.2	453530824	
U7	R911	METAL R	RNU1/2WCJ-2.2	453530224	
U7	R912	METAL R	RNU1/2WCJ-2.2	453530224	
U7	RL901	RELAY	NRL-1P5A-DC9-162	25065634	!
U7	RL901 or	RELAY	NRL-1P5A-DC9-150	25065601	!
U7	RL901 or	RELAY	NRL-1P5A-DC9-152	25065603	!
U7	JL551A	WIRE HOL	NSCT-4P875	25051088	
U7	JL901B	WIRE HOL	NSCT-4P895	25051108	
U7	P501B	SOCKET	NSCT-7P1022	25051232	
U7	P903B	SOCKET	NSCT-6P1021	25051231	

*[NOTES] R551-R556 : Tolerance +/-1% class.

When you exchange, surely use the appointed parts.

U8 SPEAKER TERMINAL PC BOARD (NAETC-7555-2B/2C)

REF NO.	PART NAME	DESCRIPTION	PART NO.	NOTES	
U8	L551	S COIL	S-1.3C	231176S	DT
U8	L551	S COIL	S-1.3C	231176S	GT,GR,GQ
U8	L552	S COIL	S-1.3C	231176S	DT
U8	L552	S COIL	S-1.3C	231176S	GT,GR,GQ
U8	P551	TRM	NTM-4PDML237	25060306	SPEAKERS
U8	P552	PIN JACK	NPJ-1PDBL382	25045567	SUBWOOFER
U8	R565	METAL O R	RS1/2WBJ-5.6	443520564	DT
U8	R565	METAL O R	RS1/2WBJ-5.6	443520564	GT,GR,GQ
U8	R566	METAL O R	RS1/2WBJ-5.6	443520564	DT
U8	R566	METAL O R	RS1/2WBJ-5.6	443520564	GT,GR,GQ
U8	JL502B	WIRE TRAP	NPLG-5P588	25055626	
U8	JL551B	WIRE TRAP	NPLG-4P587	25055625	

U9 CD & MICROPROCESSOR PC BOARD (NADG-7557-2B/2C)

REF NO.	PART NAME	DESCRIPTION	PART NO.	NOTES	
U9	Q102	IC	CXA2581N	22241585R2	
U9	Q103	IC	CXD3017Q	22241808R3	
U9	Q201	IC	BA5984FP	22241696R2	
U9	Q206	IC	TC74VHCT00AFT	22274000GR2	or
U9	Q206 or	IC	TC74VHCT00AFT	22274000GR2TO	or
U9	Q206 or	IC	SN74HCT00APW	22274000KR2TI	
U9	Q352	IC	TC74VHCT08AFT	22274008GR2TO	or
U9	Q352 or	IC	SN74HCT08APW	22274008KR2TI	
U9	Q701	IC	MPLD184225GC-111-8RT	22241804R3	MAIN MICROPROCESSOR
U9	Q702	IC	BR93LC46F-WE2	22241609R2	
U9	Q707	IC	TC74VHCT32AFT	22274032GR2TO	or
U9	Q707 or	IC	SN74HCT32APW	22274032KR2TI	
U9	Q708	IC	TC74VHCT32AFT	22274032GR2TO	or
U9	Q708 or	IC	SN74HCT32APW	22274032KR2TI	
U9	Q204	IC(REGULATOR)	MPC29L33J	22278033F	
U9	Q356	IC(REGULATOR)	MPC29L33J	22278033F	
U9	Q711	IC(REGULATOR)	78M56(NJM78M56FA)	222780565JRC	
U9	Q101	TR	2SA950-O	2211503	or
U9	Q101 or	TR	2SA950-Y	2211504	
U9	Q151	TR	2SD1468S-R	2215024	or
U9	Q151 or	TR	2SD1468S-S	2215025	
U9	Q152	TR	2SD1468S-R	2215024	or

U9	Q152 or	TR	2SD1468S-S	2215025
U9	Q153	TR	DTA124EKA	2216240R2 or
U9	Q153 or	TR	RN2403	2214540R2
U9	Q154	TR	DTA124EKA	2216240R2 or
U9	Q154 or	TR	RN2403	2214540R2
U9	Q202	TR	2SA950-O	2211503 or
U9	Q202 or	TR	2SA950-Y	2211504
U9	Q203	TR	DTC114EKA	2216250R2 or
U9	Q203 or	TR	RN1402	2214470R2
U9	Q351	TR	DTA124EKA	2216240R2 or
U9	Q351 or	TR	RN2403	2214540R2
U9	Q703	TR	DTA124EKA	2216240R2 or
U9	Q703 or	TR	RN2403	2214540R2
U9	Q704	TR	DTA124EKA	2216240R2 or
U9	Q704 or	TR	RN2403	2214540R2
U9	Q705	TR	DTA124EKA	2216240R2 or
U9	Q705 or	TR	RN2403	2214540R2
U9	Q706	TR	DTA124EKA	2216240R2 or
U9	Q706 or	TR	RN2403	2214540R2
U9	Q710	TR	DTC114EKA	2216250R2 or
U9	Q710 or	TR	RN1402	2214470R2
U9	D101	C-DIODE	1SS352	223234R2 or
U9	D101 or	C-DIODE	1SS355	223269R2
U9	D701	C-DIODE	1SS352	223234R2 or
U9	D701 or	C-DIODE	1SS355	223269R2
U9	D702	ZENER D	UDZS5.6B	224550560R2 or
U9	D702 or	ZENER D	RD5.6SB2	224370562R2
U9	D703	C-DIODE	1SS355	223269R2 or
U9	D703 or	C-DIODE	1SS352	223234R2
U9	D704	C-DIODE	1SS355	223269R2 or
U9	D704 or	C-DIODE	1SS352	223234R2
U9	D705	C-DIODE	1SS355	223269R2 or
U9	D705 or	C-DIODE	1SS352	223234R2
U9	D706	C-DIODE	1SS355	223269R2 or
U9	D706 or	C-DIODE	1SS352	223234R2
U9	X101	CRYSTAL	HC-49U/03 33.8688MHz	3010325
U9	X701	CRYSTAL	HC-49/U03C12.500MHz	3010362
U9	L101	CHOKE COIL	NCH-1475	231237K100R2
U9	L102	CHOKE COIL	BLM21B222SPT	230921R2
U9	L103	CHOKE COIL	BLM21B222SPT	230921R2
U9	L202	CHOKE COIL	BLM21B222SPT	230921R2
U9	L701	CHOKE COIL	BLM21B222SPT	230921R2
U9	C101	VR C	CE04W6.3V-100M(VR)	394621017
U9	C104	VR C	CE04W16V-10M(VR)	394641007
U9	C108	VR C	CE04W6.3V-100M(VR)	394621017
U9	C117	VR C	CE04W50V-0.47M(VR)	394684797
U9	C123	VX C	CE04W6.3V-470M(VX)	393324717
U9	C129	VR C	CE04W16V-10M(VR)	394641007
U9	C155	VX C	CE04W35V-22M(VX)	393362207
U9	C156	VX C	CE04W35V-22M(VX)	393362207
U9	C208	VR C	CE04W6.3V-220M(VR)	394622217
U9	C210	VR C	CE04W6.3V-1000M(VR)	394621027
U9	C211	VR C	CE04W6.3V-220M(VR)	394622217
U9	C217	VR C	CE04W16V-10M(VR)	394641007
U9	C353	VR C	CE04W6.3V-220M(VR)	394622217

U9	C359	VR C	CE04W16V-10M(VR)	394641007	
U9	C362	VR C	CE04W16V-10M(VR)	394641007	
U9	C705	TRIMMER	NTC-30P14	3060016	CLOCK ADJUST
U9	C711	VR C	CE04W50V-1.0M(VR)	394680107	
U9	C713	VR C	CE04W6.3V-220M(VR)	394622217	
U9	C715	VR C	CE04W16V-10M(VR)	394641007	
U9	C717	VR C	CE04W16V-10M(VR)	394641007	
U9	C719	EDL C	DX-5R5L104	3000078	DT
U9	C719	EDL C	DX-5R5L104	3000078 or	GT,GR,GQ
U9	C719 or	EDL C	EECS5R5T104S	3000118 or	DT
U9	C719 or	EDL C	EECS5R5T104S	3000118	GT,GR,GQ
U9	P151A	P PLUG	NPLG-10P1092	25056153	
U9	P702A	P PLUG	NPLG-20P1097	25056158	
U9	P103	PLUG	NPLG-2P29	25055038	
U9	P104	PLUG	NPLG-4P351	25055368	
U9	P106	PLUG	NPLG-3P32	25055042	
U9	P201	PLUG	NPLG-6P134	25055150	
U9	P203A	PLUG	NPLG-3P131	25055147	DT
U9	P203A	PLUG	NPLG-3P131	25055147	GT,GR,GQ
U9	P801A	PLUG	NPLG-11P139	25055155	
U9	P102B	SOCKET	NSCT-16P2407	25052510 or	
U9	P102Bor	SOCKET	NSCT-16P2213	25052316	
U9	P202	SOCKET	NSCT-6P2099	25052202	
U9	P351	SOCKET	NSCT-29P2226	25052329 or	
U9	P351 or	SOCKET	NSCT-29P2420	25052523	
U9	P352B	SOCKET	NSCT-5P97	25050269	
U9	P703B	WIRE TRAP	NPLG-7P590	25055628	

U10 CONNECTOR PC BOARD(NAETC-7590-2B/2C)

REF NO.	PART NAME	DESCRIPTION	PART NO.	NOTES
U10	P101	SOCKET	NSCT-16P2380	25052483
U10	P102A	SOCKET	NSCT-16P2380	25052483

PACKING VIEW PARTS LIST**FR-N3X**

<GR> : Chinese model only

	REF NO,NAME	DESCRIPTION	PART NO.	NOTES
Packing view	A601	PAD (UP)	29092061	
Packing view	A607	SHEET 800 x 600	29095864	
Packing view	A610	TAPE (SEKOHAN)JN111U	29110149	
Packing view	A613	PP TAPE W48 OPP TAPE	29110148	
Packing view	A616	POLY BAG 350 x 200 x W250	29100201	
Packing view	A701	CARTON ---	29053917	
Packing view	A707	EAN LABEL	29363158	
Packing view	A801	ANT COIL NMA-3057	232140	
Packing view	A803	FM-ANT-AS P	292116	
Packing view	A804	FM ADPTER YAE21-0237	25065462	
Packing view	A811	REMO CON RC-497S	24140497	
Packing view	A812	BATTERY UM-3	3010054	
Packing view	A821	INS MANUAL E(FR-N3X)	29343349	
Packing view	A822	INS MANUAL CT(FR-N3X)	29343350	
Packing view	A823	INS MANUAL CS(FR-N3X)	29343351	UGR
Packing view	A826	INST SHEET E.T(FR-155/FR-V77)	29355340	

ONKYO CORPORATION

Sales & Product Planning Div. : 2-1, Nisshin-cho, Neyagawa-shi, OSAKA 572-8540, JAPAN
Tel: 072-831-8111 Fax: 072-833-5222

ONKYO U.S.A. CORPORATION

18 Park Way, Upper Saddle River, N.J. 07458, U.S.A.
Tel: 201-785-2600 Fax: 201-785-2650 E-mail: onkyo@onkyousa.com

ONKYO EUROPE ELECTRONICS GmbH

Industriestrasse 20, 82110 Germering, GERMANY
Tel: 089-849-320 Fax: 089-849-3265 E-mail: info@onkyo.de

ONKYO CHINA LIMITED

Units 2102-2107, Metroplaza Tower I, 223 Hing Fong Road, Kwai Chung,
N.T., HONG KONG Tel: 852-2429-3118 Fax: 852-2428-9039