

ONKYO SERVICE MANUAL

7.1-CH HOME THEATER SPEAKER PACKAGE MODEL HTP-530(B)/(S)

-- Powered Subwoofer --
"SKW-530"



-- Surround Back Speaker (L/R) --
"SKB-530"



-- Front Speakers (L/R) --
"SKF-530F"



-- Center Speaker --
"SKC-530C"



-- Surround Speakers (L/R) --
"SKM-530S"



Black and Silver models

BMDD	120V AC, 60Hz	---	---
BMDC	120V AC, 60Hz	SMDC	120V AC, 60Hz
BMPA	230-240V AC, 50Hz	SMPA	230-240V AC, 50Hz

SAFETY-RELATED COMPONENT WARNING!!

COMPONENTS IDENTIFIED BY MARK \triangle ON THE SCHEMATIC DIAGRAM AND IN THE PARTS LIST ARE CRITICAL FOR RISK OF FIRE AND ELECTRIC SHOCK. REPLACE THESE COMPONENTS WITH ONKYO PARTS WHOSE PART NUMBERS APPEAR AS SHOWN IN THIS MANUAL.

MAKE LEAKAGE-CURRENT OR RESISTANCE MEASUREMENTS TO DETERMINE THAT EXPOSED PARTS ARE ACCEPTABLY INSULATED FROM THE SUPPLY CIRCUIT BEFORE RETURNING THE APPLIANCE TO THE CUSTOMER.

SPECIFICATIONS

Powered Subwoofer (SKW-530)

Type :	Bass-reflex
Input sensitivity/impedance :	330 mV / 100 kohm
Maximum output power :	230 W (Dynamic Power)
Frequency response :	25 Hz - 150 Hz
Cabinet capacity :	1.36 cubic feet (38.5 L)
Dimensions (W x H x D) :	10-13/16" x 20-3/8" x 16-3/16" (275 x 518 x 411 mm)
Weight :	30 lbs. (13.6 kg)
Driver unit :	10 inch Cone Woofer
Power supply :	North American : AC 120 V, 60 Hz Australian : AC 230-240 V, 50 Hz
Power consumption :	North American : 150 W Australian : 134 W
Other :	Auto Standby function

Center Speaker (SKC-530C)

Type :	2 Way Bass-reflex
Impedance :	8 ohm
Maximum input power :	110 W
Output sound pressure level :	86 dB/W/m
Frequency response :	55 Hz - 50 kHz
Crossover frequency :	4.5 kHz
Cabinet capacity :	0.31 cubic feet (8.7 L)
Dimensions (W x H x D) :	17-1/16" x 6-3/16" x 7-7/8" (434 x 157 x 200 mm)
Weight :	8.6 lbs. (3.9 kg)
Drivers unit :	5 inch (12 cm) OMF Cone Woofer x 2 1 inch (2.5 cm) Balanced Dome Tweeter
Terminal :	Color-coded push type
Other :	Magnetic shielding

Front Speaker (SKF-530F)

Type :	2 Way Bass-reflex
Impedance :	8 ohm
Maximum input power :	110 W
Output sound pressure level :	86 dB/W/m
Frequency response :	55 Hz - 50 kHz
Crossover frequency :	4.5 kHz
Cabinet capacity :	0.31 cubic feet (8.7 L)
Dimensions (W x H x D) :	6-3/16" x 17-1/16" x 7-7/8" (157 x 434 x 200 mm)
Weight :	8.6 lbs. (3.9 kg)
Drivers unit :	5 inch (12 cm) OMF Cone Woofer x 2 1 inch (2.5 cm) Balanced Dome Tweeter
Terminal :	Color-coded push type
Other :	Magnetic shielding

Surround Speaker (SKM-530S/SKB-530)

Type :	2 Way Bass-reflex
Impedance :	8 ohm
Maximum input power :	110 W
Output sound pressure level :	82 dB/W/m
Frequency response :	60 Hz - 20 kHz
Crossover frequency :	10 kHz
Cabinet capacity :	0.07 cubic feet (2.1 L)
Dimensions (W x H x D) :	6-7/8" x 10-7/16" x 4" (175 x 265 x 102 mm)
Weight :	3.1 lbs. (1.4 kg)
Drivers unit :	3-1/8 inch (8 cm) Cone Woofer 3/4 inch (2 cm) Ceramic Tweeter
Terminal :	Color-coded push type
Other :	Magnetic shielding

Specifications and appearance are subject to change without prior notice.

EXPLODED VIEWS-1

SKW-530 : POWERED SUBWOOFER

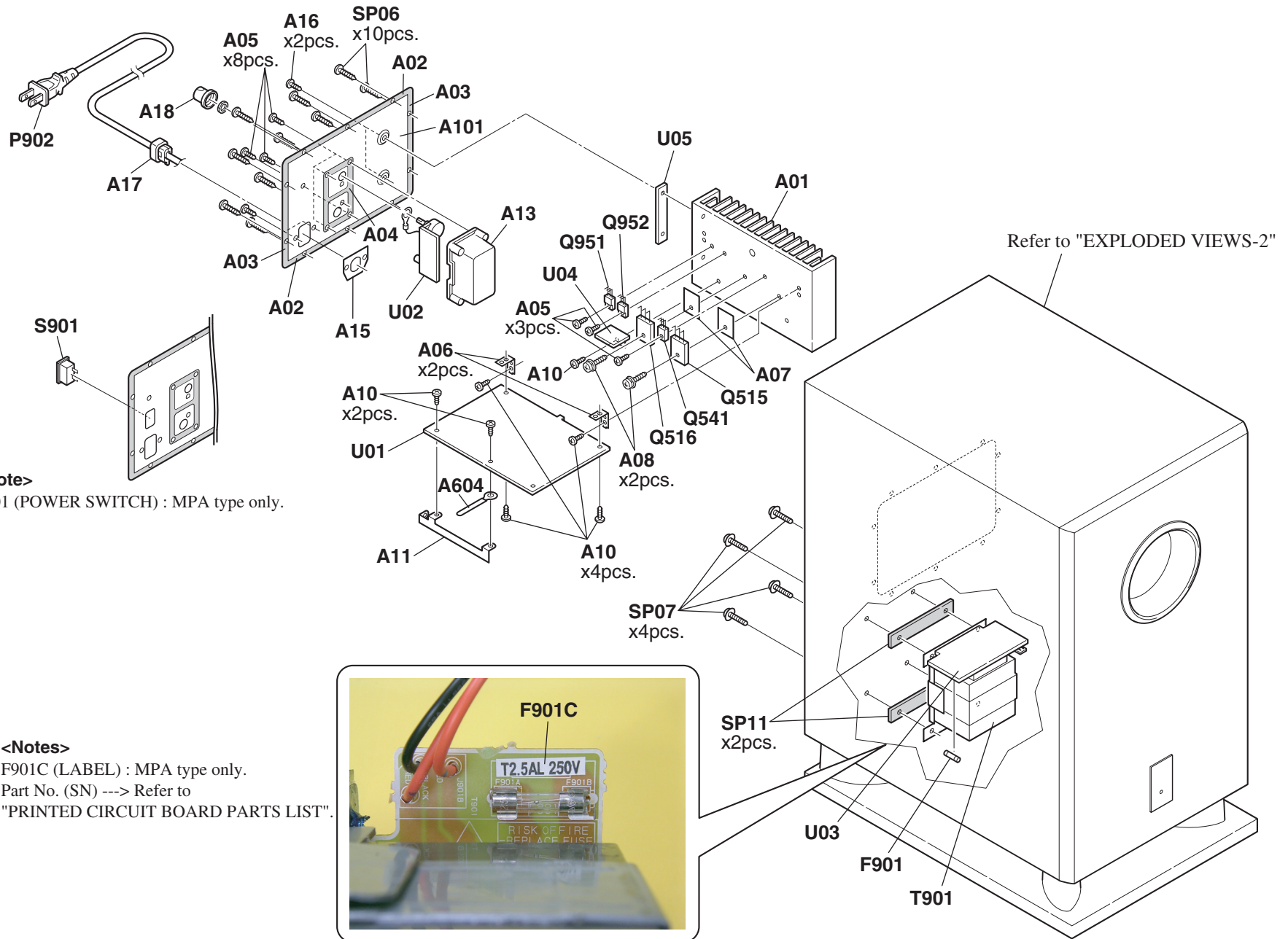

<Note>
S901 (POWER SWITCH) : MPA type only.

<Notes>
F901C (LABEL) : MPA type only.
Part No. (SN) ----> Refer to
"PRINTED CIRCUIT BOARD PARTS LIST".

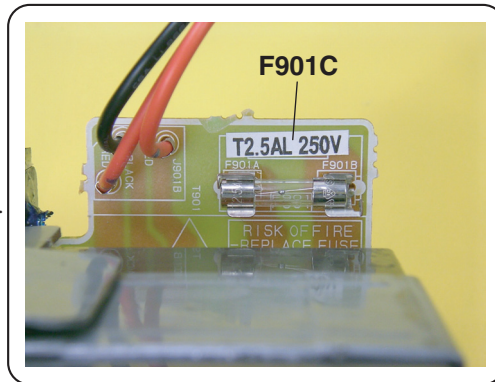

EXPLODED VIEWS-2
SKW-530 : POWERED SUBWOOFER

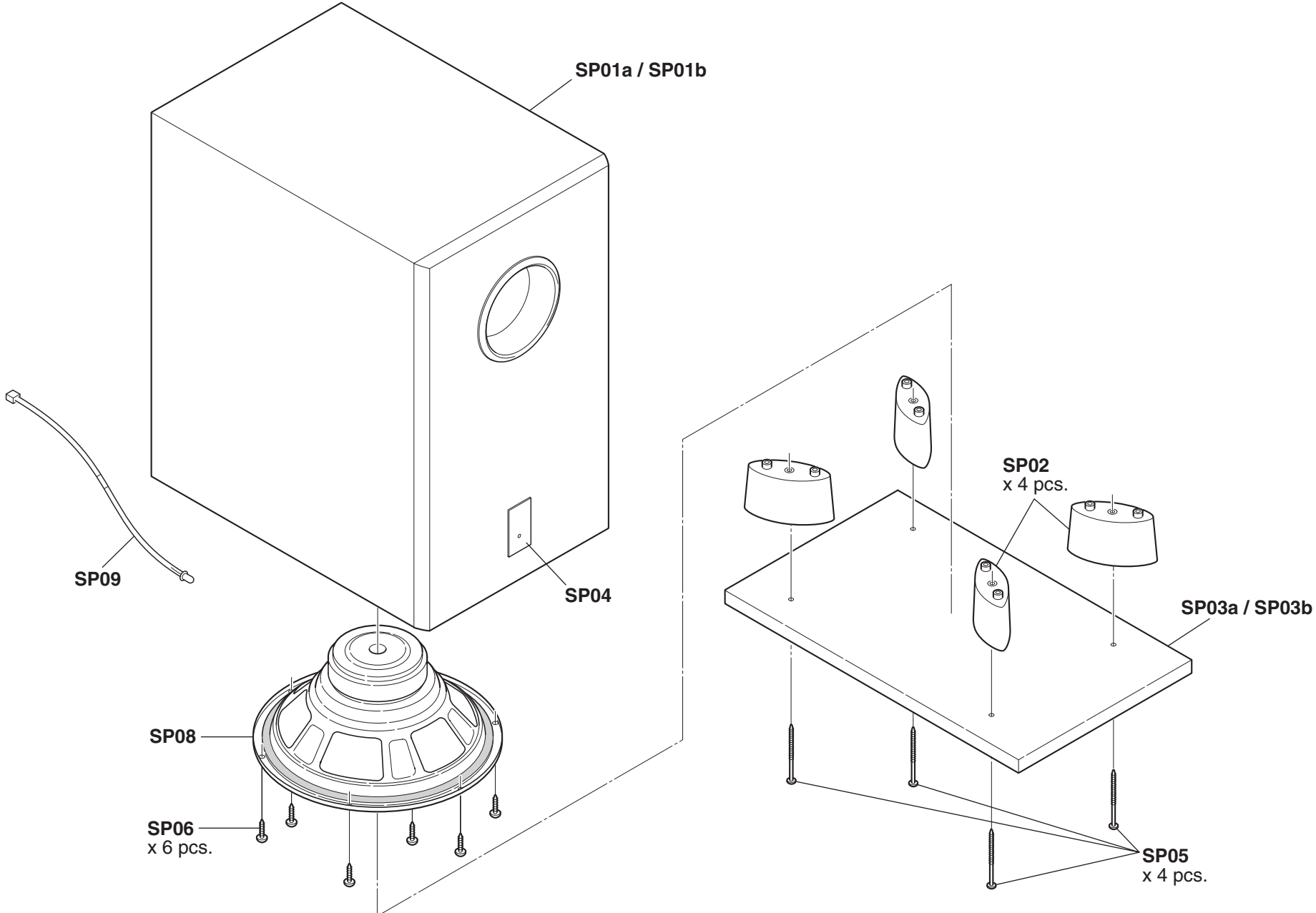

EXPLODED VIEWS-3

SKF-530F <L> / SKF-530F <R>

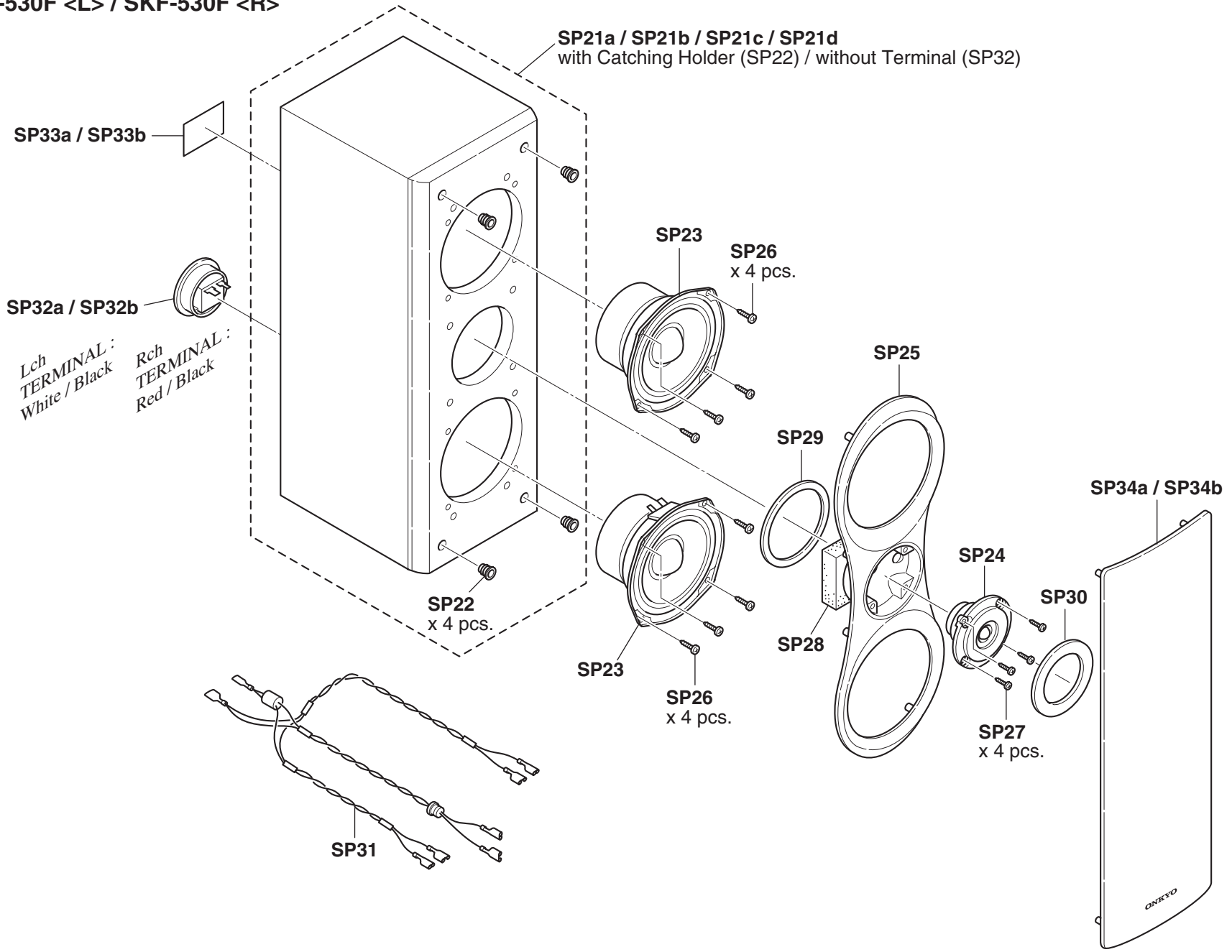

EXPLODED VIEWS-4
SKC-530C

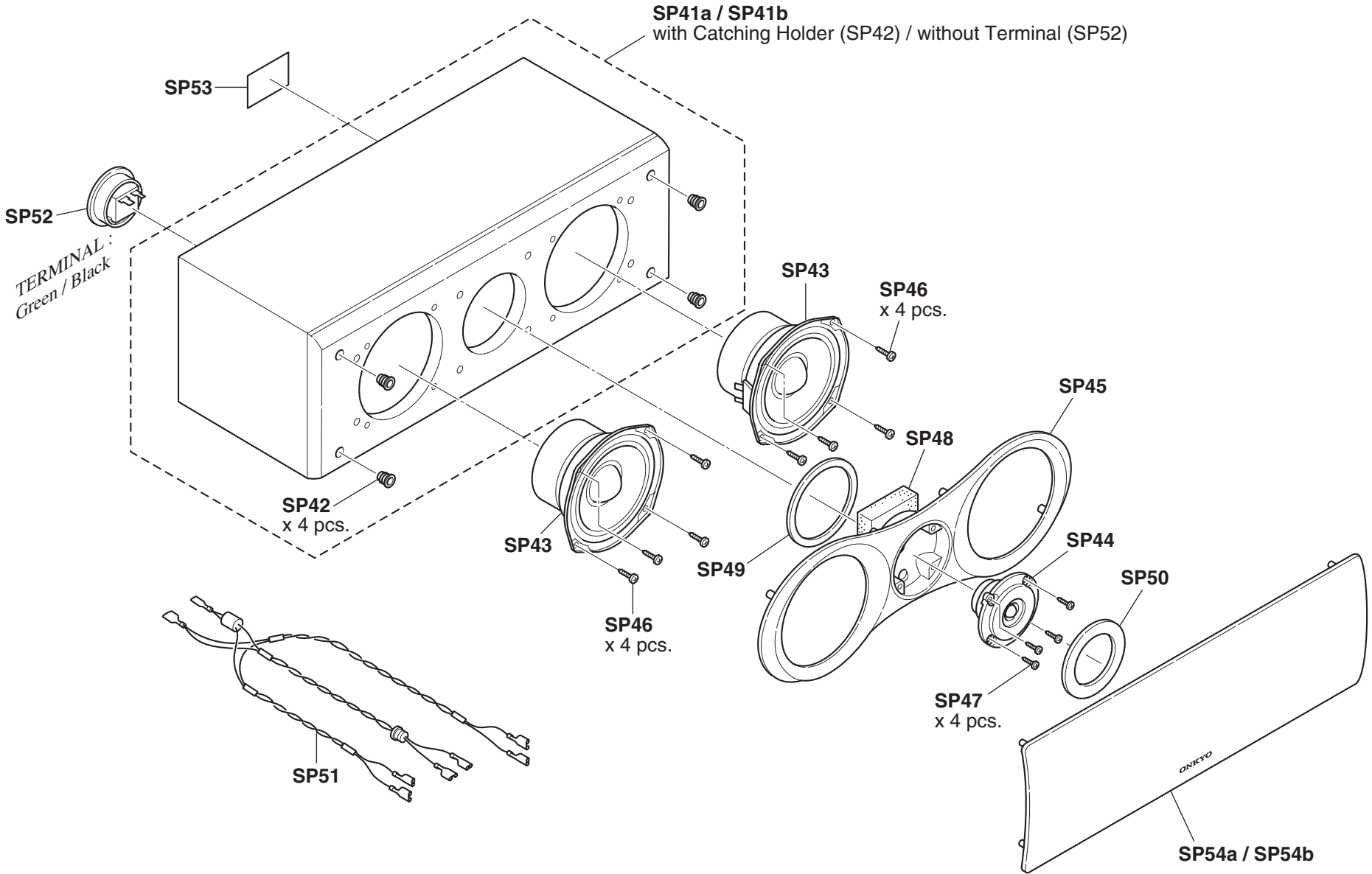

EXPLODED VIEWS-5

SKM-530S <L> / SKM-530S <R> / SKB-530 <L> / SKB-530 <R>

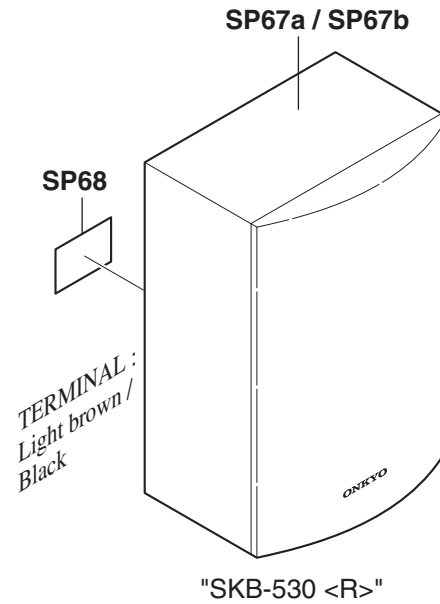
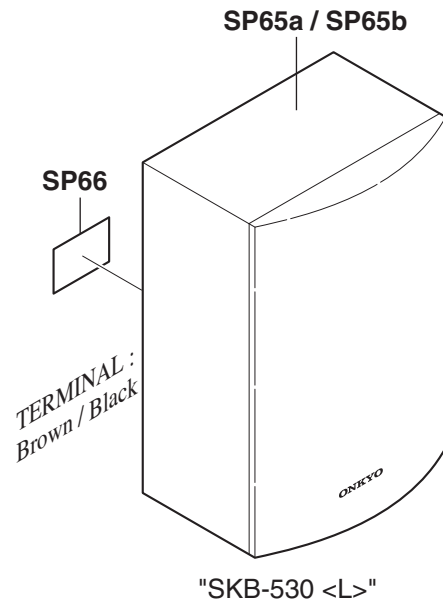
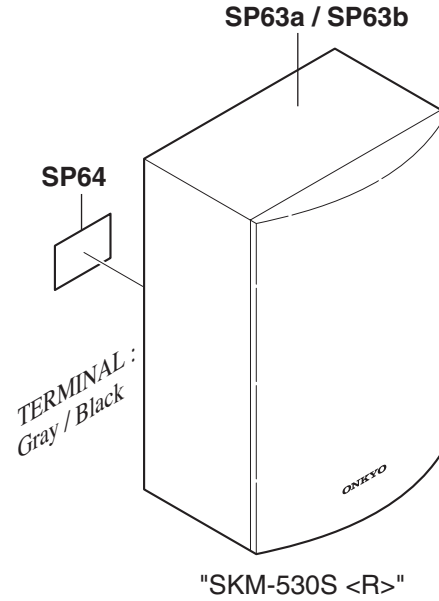
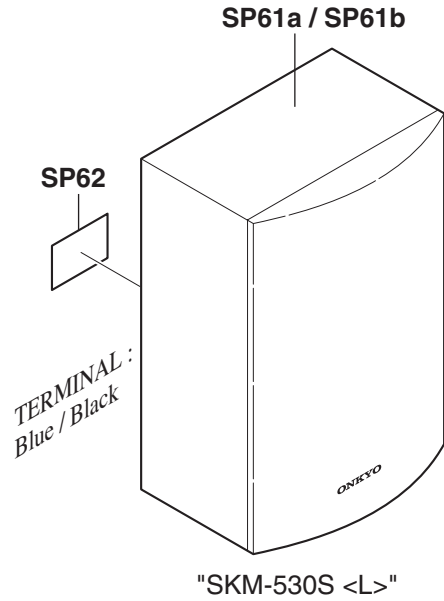

A

B

C

D

SCHEMATIC DIAGRAM

SKW-530 :
POWERED
SUBWOOFER

U02
INPUT TERMINAL
PC BOARD

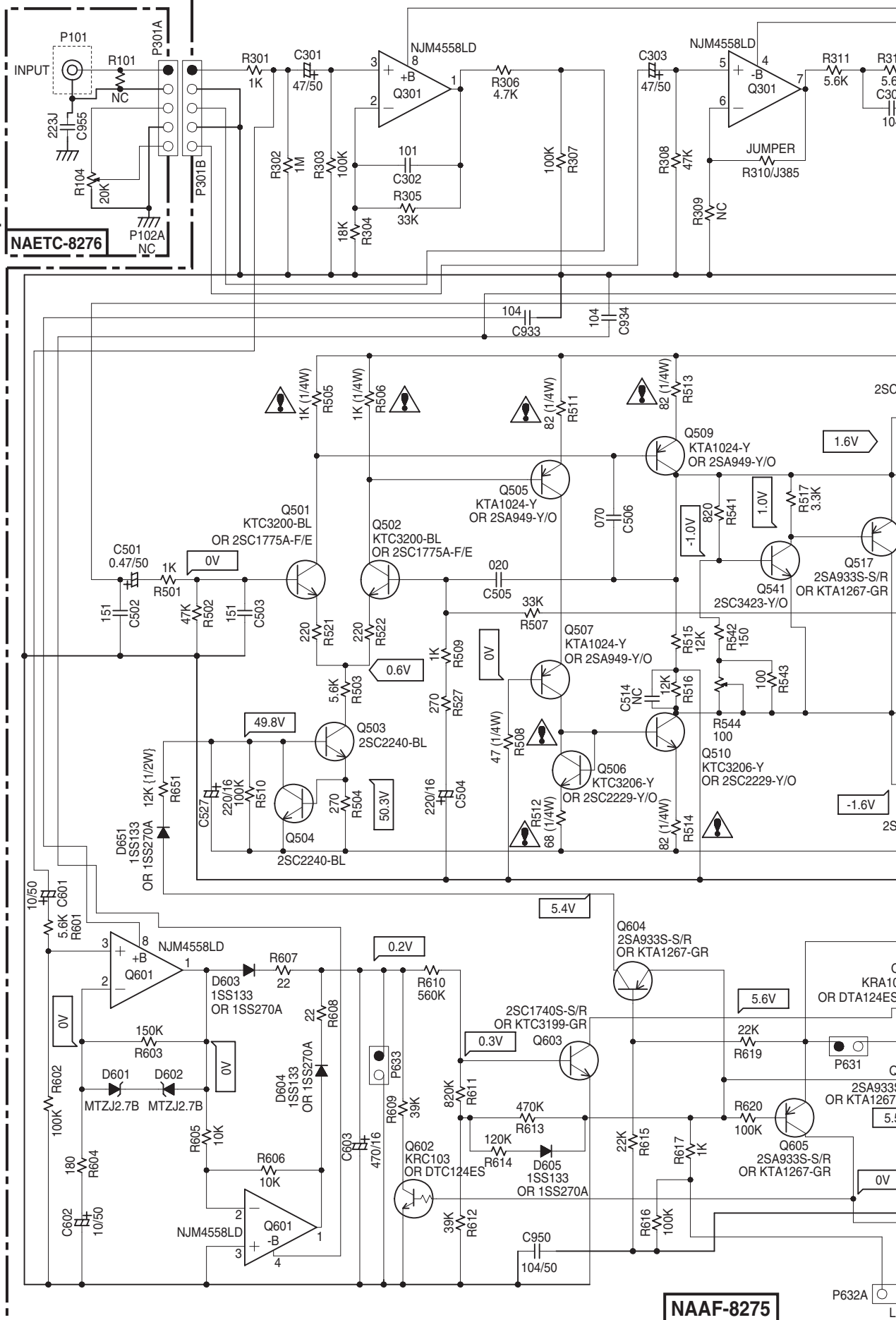

1

2

3

4

5

NAAF-8275

U01 AMPLIFIER PC BOARD

E

F

G

H

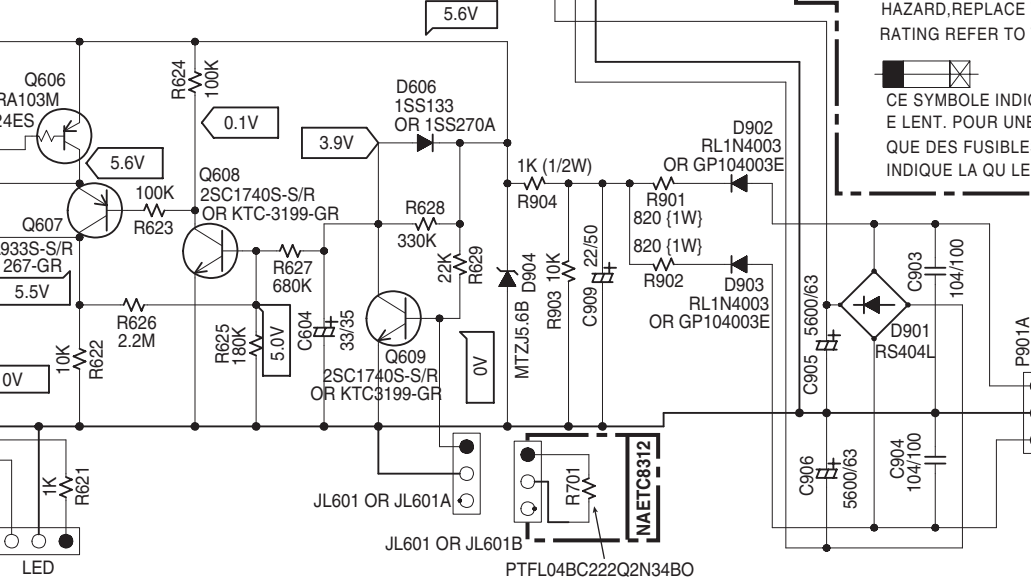
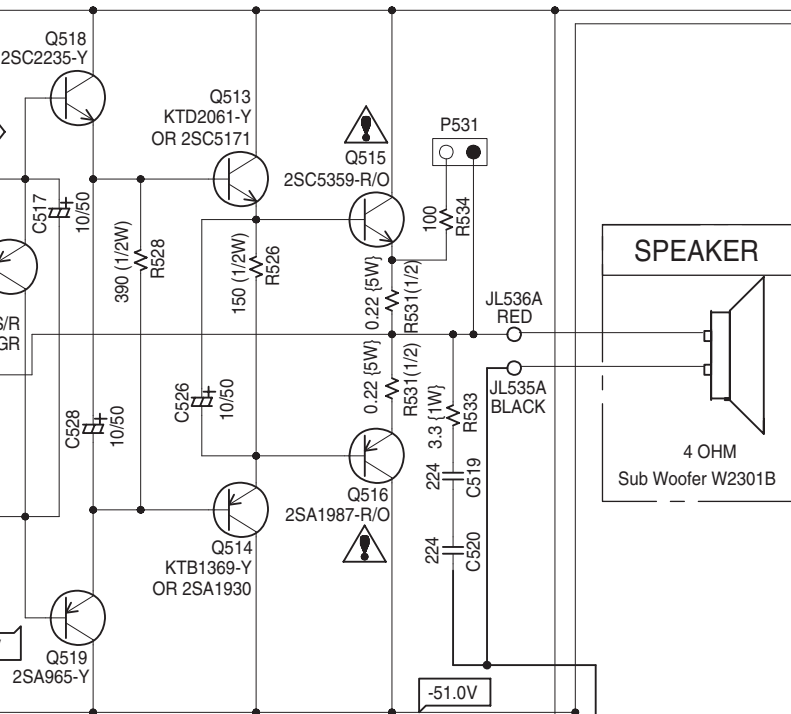
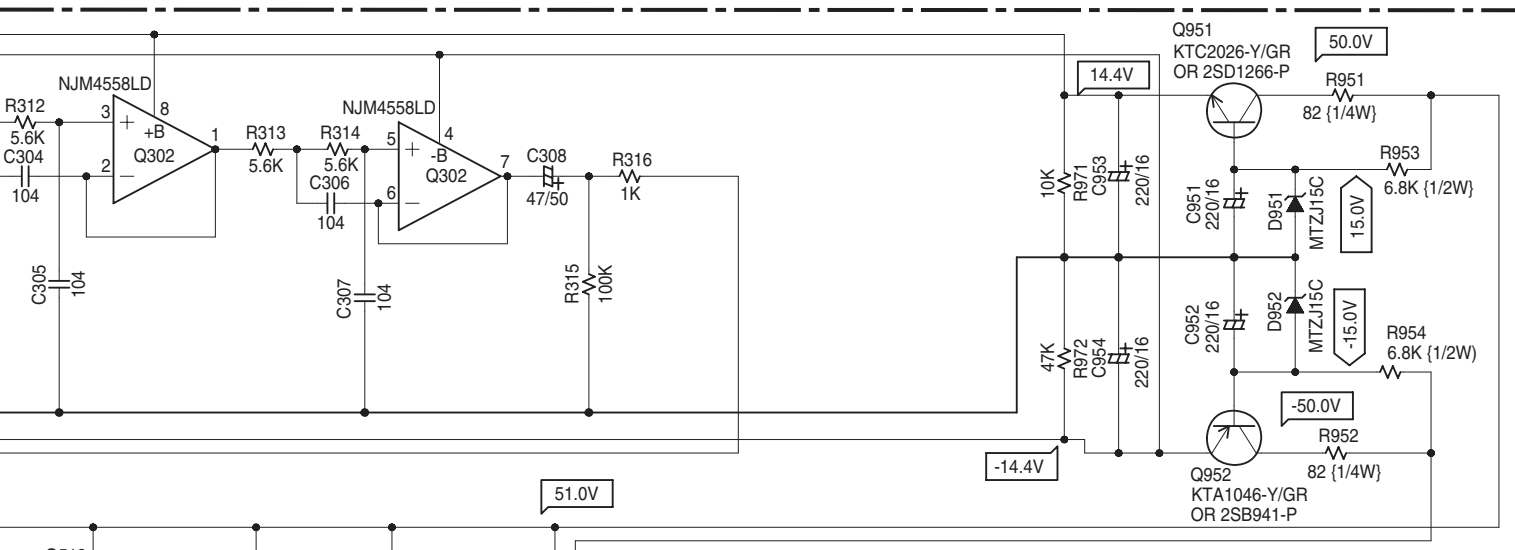

U04 THERMAL SENSOR PC BOARD

U03 POWER TRANSFORMER PC BOARD

NOTE

- THE COMPONENTS IDENTIFIED BY MARK ARE CRITICAL FOR SAFETY. REPLACE ONLY WITH PART NUMBER SPECIFIED.
- VOLTAGE (MEASURED WITH VOLTMETER) IS DC VOLTAGE.(NO INPUT SIGNAL).
- ALL PNP TRANSISTORS ARE EQUIVALENT TO 2SA1015-GR UNLESS OTHERWISE NOTED.
- ALL NPN TRANSISTORS ARE EQUIVALENT TO 2SC1815-GR UNLESS OTHERWISE NOTED.
- ALL DIODES ARE EQUIVALENT TO 1SS133 UNLESS OTHERWISE NOTED.
- ELECTROLYTIC CAPACITORS () ARE IN uF/WV.
- ALL CAPACITORS ARE IN pF/50V UNLESS OTHERWISE NOTED.
EX) 030- 3pF 330- 33pF 331- 330pF 333- 0.033uF
- ALL RESISTORS ARE IN OHMS 1/4WATTS UNLESS OTHERWISE NOTED.
- THE THICK LINES ON PC BOARD ARE THE PRINTING SIDE OF THE PARTS.
EX) PRINTING SIDE
- CIRCUIT IS SUBJECT TO CHANGE FOR IMPROVEMENT.

CAUTION



FOR CONTINUED PROTECTION AGAINST FIRE HAZARD, REPLACE ONLY WITH FUSE OF SAME TYPE AND RATING INDICATED.

ATTENTION



AFIN D'ASSURER UNE PROTECTION PERMANENTE CONTRE LES RISQUES D'INCENDIE, REMPLACER UNIQUEMENT PAR UN FUSIBLE DE MEME TYPE ET CALIBRATION COMME INDIQUE.

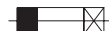

THIS SYMBOL LOCATED NEAR THE FUSE INDICATES THAT THE FUSE USED IS SLOW OPERATING TYPE FOR CONTINUED PROTECTION AGAINST FIRE HAZARD,REPLACE WITH SAME TYPE FUSE. FOR FUSE RATING REFER TO THE MARKING ADJACENT TO THE SYMBOL

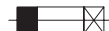

CE SYMBOLE INDIQUE QUE LE FUSIBLE UTILISE EST E LENT. POUR UNE PROTECTION PERMANENTE,N'UTILISER QUE DES FUSIBLES DE MEME TYPE. CE DARNIER EST INDIQUE LA QU LE PRESENT SYMBOLE EST APPOSE.

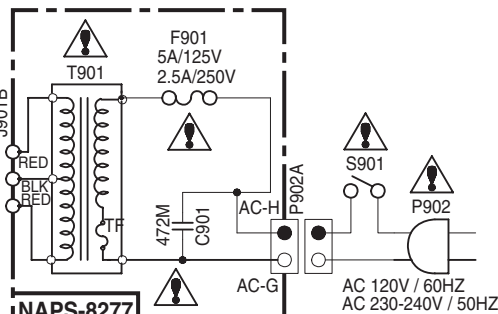

NAPS-8277

AC 120V / 60HZ
AC 230-240V / 50HZ

SCHEMATIC DIAGRAM

SKW-530 :
POWERED
SUBWOOFER

U02
INPUT TERMINAL
PC BOARD

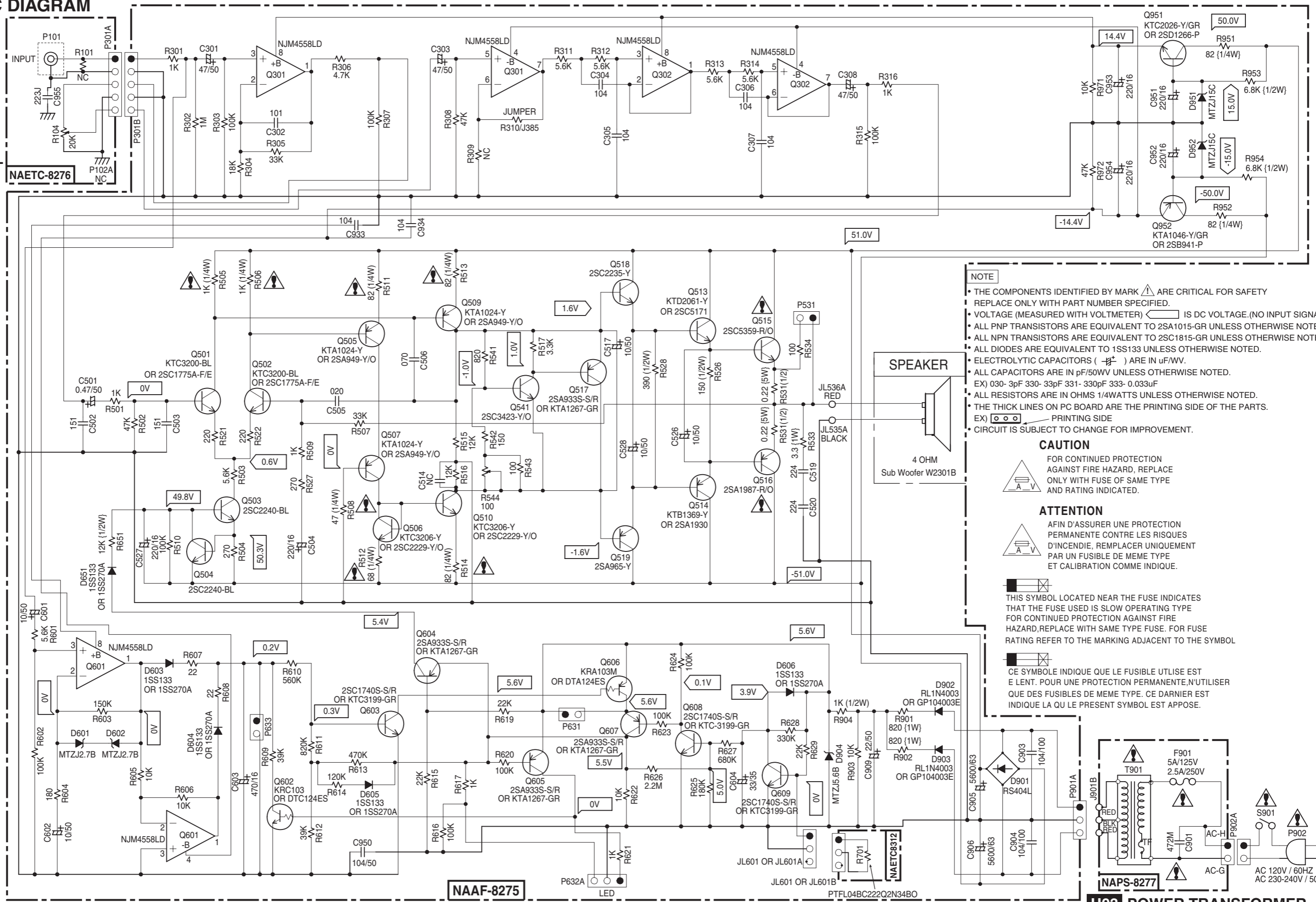

- NOTE**
- THE COMPONENTS IDENTIFIED BY MARK ARE CRITICAL FOR SAFETY. REPLACE ONLY WITH PART NUMBER SPECIFIED.
 - VOLTAGE (MEASURED WITH VOLTMETER) IS DC VOLTAGE. (NO INPUT SIGNAL).
 - ALL PNP TRANSISTORS ARE EQUIVALENT TO 2SA1015-GR UNLESS OTHERWISE NOTED.
 - ALL NPN TRANSISTORS ARE EQUIVALENT TO 2SC1815-GR UNLESS OTHERWISE NOTED.
 - ALL DIODES ARE EQUIVALENT TO 1SS133 UNLESS OTHERWISE NOTED.
 - ELECTROLYTIC CAPACITORS () ARE IN uF/WV.
 - ALL CAPACITORS ARE IN pF/50V UNLESS OTHERWISE NOTED. EX) 030- 3pF 330- 33pF 331- 330pF 333- 0.03uF
 - ALL RESISTORS ARE IN OHMS 1/4WATTS UNLESS OTHERWISE NOTED.
 - THE THICK LINES ON PC BOARD ARE THE PRINTING SIDE OF THE PARTS. EX) PRINTING SIDE
 - CIRCUIT IS SUBJECT TO CHANGE FOR IMPROVEMENT.

CAUTION

FOR CONTINUED PROTECTION AGAINST FIRE HAZARD, REPLACE ONLY WITH FUSE OF SAME TYPE AND RATING INDICATED.

ATTENTION

AFIN D'ASSURER UNE PROTECTION PERMANENTE CONTRE LES RISQUES D'INCENDIE, REMPLACER UNIQUEMENT PAR UN FUSIBLE DE MEME TYPE ET CALIBRATION COMME INDIQUE.

THIS SYMBOL LOCATED NEAR THE FUSE INDICATES THAT THE FUSE USED IS SLOW OPERATING TYPE FOR CONTINUED PROTECTION AGAINST FIRE HAZARD, REPLACE WITH SAME TYPE FUSE. FOR FUSE RATING REFER TO THE MARKING ADJACENT TO THE SYMBOL

CE SYMBOLE INDIQUE QUE LE FUSIBLE UTILISE EST LENT. POUR UNE PROTECTION PERMANENTE, UTILISER QUE DES FUSIBLES DE MEME TYPE. CE DERNIER EST INDIQUE LA QU LE PRESENT SYMBOLE EST APPOSE.

1

2

3

4

5

NAETC-8276

NAAF-8275

PTFL04BC222Q2N34B0

NAPS-8277

U01 AMPLIFIER PC BOARD

U04 THERMAL SENSOR PC BOARD

U03 POWER TRANSFORMER PC BOARD

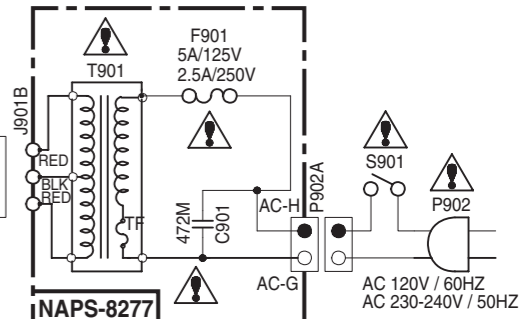
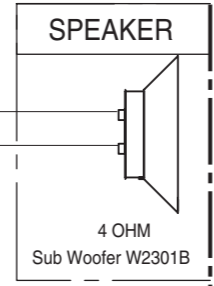

A

B

C

D

PRINTED CIRCUIT BOARD VIEWS-2

SKW-530 : POWERED SUBWOOFER

1

U02 INPUT TERMINAL PC BOARD (NAETC-8276)

Soldering side

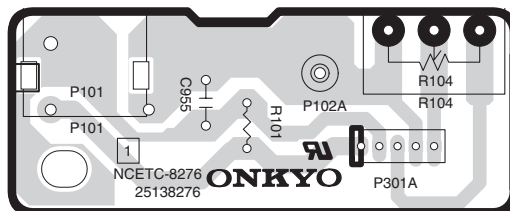

2

U03 POWER TRANSFORMER PC BOARD (NAPS-8277)

Soldering side

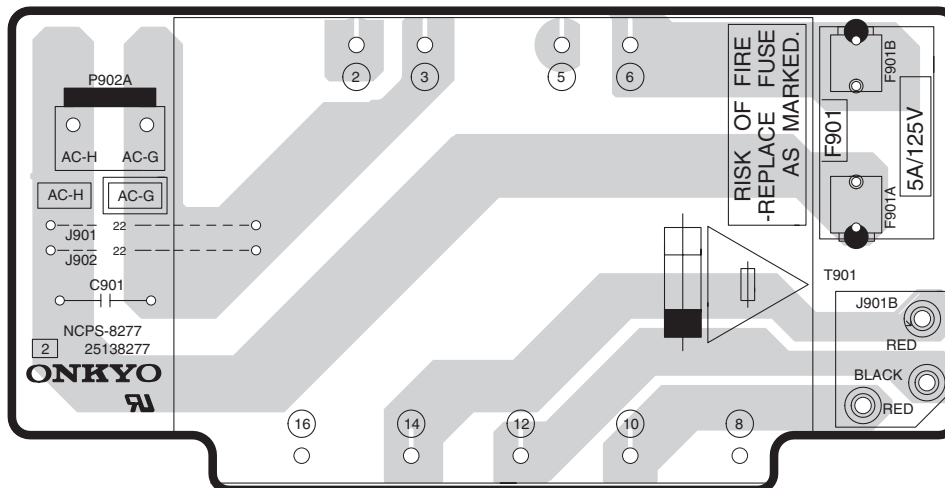

3

4

U04 THERMAL SENSOR PC BOARD (NAETC-8312)

Soldering side

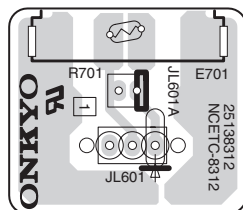

5

U05 HOLDER PC BOARD (NAETC-8317)

No PC board view

ADJUSTMENT PROCEDURE

SKW-530 : POWERED SUBWOOFER /

ADJUSTMENT OF IDLING CURRENT

1. Before adjustment of idling current, turn the trimming resistor R544 to counter clockwise.
2. Short test point P631 for Amplifier is under active mode.
3. Connect the DC voltmeter to test point P531.
4. After turn POWER to ON, adjust the trimming resistor R544 so that the reading of voltmeter becomes 0.25 mV.

<Note> No speaker load and No input signal.

5. Confirm the voltage of above point after five minutes.
6. When less than 4.40 mV : Readjust the trimming resistor above so that the voltage becomes 4.5 mV to 5.0 mV.
When 4.41 mV to 5.50 mV : Not necessary to adjust.
When more than 5.51 mV : Readjust the trimming resistor above so that the voltage becomes 5.0 mV to 5.5 mV.

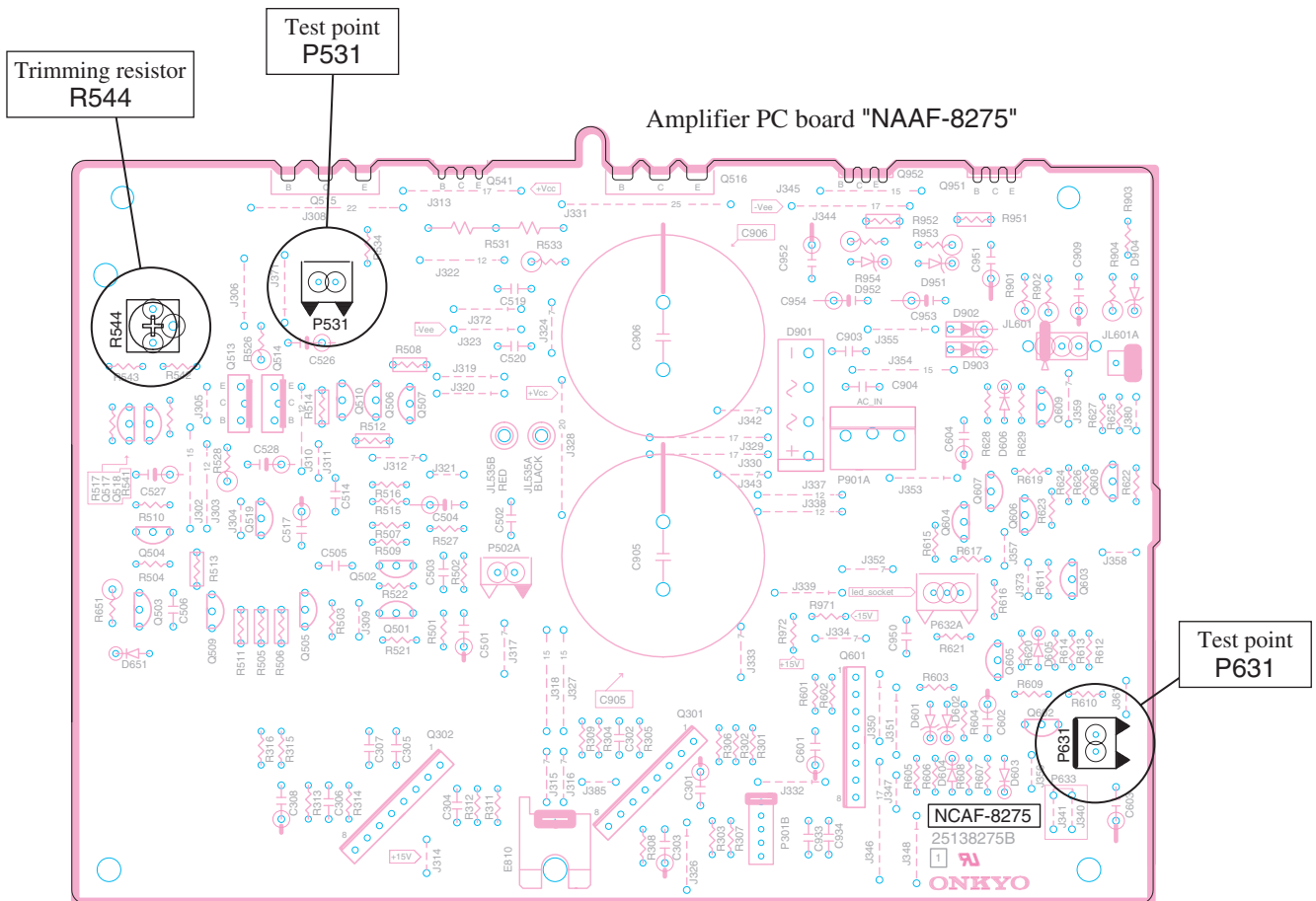

HTP-530

EXPLODED VIEWS PARTS LIST

NOTE : THE COMPONENTS IDENTIFIED BY THE MARK
! ARE CRITICAL FOR RISK OF FIRE AND
ELECTRIC SHOCK. REPLACE ONLY WITH PART
NUMBER SPECIFIED.

<Notes>

(B) : Black model

(S) : Silver model

<L> : Lch

<R> : Rch

<MDD> : MDD, MDC only

<MPA> : MPA only

REF. NO.	PART NAME	DESCRIPTION	Q'TY	PART NO. (SN)	REMARKS
EXPLODED:	SKW-530 (B) : POWERED SUBWOOFER				
EXPLODED:	SKW-530 (S) : POWERED SUBWOOFER				
EXPLODED:	AMPLIFIER SECTION (SKW-530)				
EXPLODED:	Q515	TR	1	2203082	!
EXPLODED:	Q515 or	TR	(1)	2203083	!
EXPLODED:	Q516	TR	1	2203072	!
EXPLODED:	Q516 or	TR	(1)	2203073	!
EXPLODED:	Q541	TR	1	2202104	
EXPLODED:	Q541 or	TR	(1)	2202103	
EXPLODED:	Q951	TR	1	2203594	
EXPLODED:	Q951 or	TR	(1)	2203595	
EXPLODED:	Q951 or	TR	(1)	2202754	
EXPLODED:	Q952	TR	1	2203614	
EXPLODED:	Q952 or	TR	(1)	2203615	
EXPLODED:	Q952 or	TR	(1)	2202764	
EXPLODED:	<Note>				
EXPLODED:	When replacement the following the transistor, made from the same HFE rank as the original type.				
EXPLODED:	Q515, Q516, Q541, Q951, Q952				
EXPLODED:	A01	HEAT SINK	1	27160547	
EXPLODED:	A02	CUSHION	2	28141572A	
EXPLODED:	A03	CUSHION	2	28141573A	
EXPLODED:	A04	CUSHION	1	28141574	
EXPLODED:	A05	SCREW	8	838430088	
EXPLODED:	A05	SCREW	3	838430088	
EXPLODED:	A06	BRACKET	2	27130745	
EXPLODED:	A07	ISO SHEET	2	223025	
EXPLODED:	A08	SCREW	2	801433	
EXPLODED:	A10	SCREW	1	838130088	
EXPLODED:	A10	SCREW	4	838130088	
EXPLODED:	A10	SCREW	2	838130088	
EXPLODED:	A11	RETAINER	1	27141912	
EXPLODED:	A13	COVER	1	28184894	
EXPLODED:	A15	RETAINER	1	27141913	
EXPLODED:	A16	SCREW	2	838430128	
EXPLODED:	A17	BUSHING	1	27300750	!
EXPLODED:	A18	KNOB	1	28326201	
EXPLODED:	A101	REAR PANEL	1	27123442	<MDD>
EXPLODED:	A101	REAR PANEL	1	27123443A	<MPA>
EXPLODED:	A604	CLIP	1	27255004	

EXPLODED	F901	FUSE	5A-UL/T-237	1	252164	! <MDD>	
EXPLODED	F901	FUSE	2.5A-SE-EAK FUSE	1	252075	! <MPA>	
EXPLODED	F901 or	FUSE	2.5A-SE-TL250V	(1)	252275	! <MPA>	
EXPLODED	F901 or	FUSE	2.5A-SE-TL250V	(1)	252241	! <MPA>	
EXPLODED	P902	AC CORD	AS-UC-2	1	253333VOL	! <MDD>	
EXPLODED	P902 or	AC CORD	AS-UC-2	(1)	253368LTK	! <MDD>	
EXPLODED	P902	AC CORD	AC CORD	1	253385LTK	! <MPA>	
EXPLODED	T901	P TRANS	NPT-1495D	1	2301745	! <MDD>	
EXPLODED	T901	P TRANS	NPT-1495P	1	2301779	! <MPA>	
EXPLODED	S901	RC SW	NRC-11003P	1	25065573	! <MPA>	
EXPLODED	U01	AMPLIFIER PC BOARD	NAAF-8275-1A	1	1B032575-1A	! <MDD>	
EXPLODED	U01	AMPLIFIER PC BOARD	NAAF-8275-1D	1	1B032575-1D	! <MPA>	
EXPLODED	U02	INPUT TERMINAL PC BOARD	NAETC-8276-1A	1	1B032576-1A	! <MDD>	
EXPLODED	U02	INPUT TERMINAL PC BOARD	NAETC-8276-1D	1	1B032576-1D	! <MPA>	
EXPLODED	U03	POWER TRANSFORMER PC BOARD	NAAPS-8277-1A	1	1B032577-1A	! <MDD>	
EXPLODED	U03	POWER TRANSFORMER PC BOARD	NAAPS-8277-1D	1	1B032577-1D	! <MPA>	
EXPLODED	U04	THERMAL SENSOR PC BOARD	NAETC-8312-1A	1	1B032512-1A	! <MDD>	
EXPLODED	U04	THERMAL SENSOR PC BOARD	NAETC-8312-1D	1	1B032512-1D	! <MPA>	
EXPLODED	U05	HOLDER PC BOARD	NAETC-8317-1A (-1A = -1D)	1	1B032517-1A	<MDD>	
EXPLODED	U05	HOLDER PC BOARD	NAETC-8317-1D (-1D = -1A)	1	1B032517-1D	<MPA>	
EXPLODED	SPEAKER SECTION (SKW-530)						
EXPLODED	SP01a	CABINET ASS'Y	SKW-530 (B)	1	000-SKW530BSER	(B)	
EXPLODED	SP01b	CABINET ASS'Y	SKW-530 (S)	1	000-SKW530SSER	(S)	
EXPLODED	SP02	PLASTIC FOOT	---	4	D249-W53001B-00		
EXPLODED	SP03a	BOTTOM BOARD	(B)	1	105-02530B-00	(B)	
EXPLODED	SP03b	BOTTOM BOARD	(S)	1	105-02530S-00	(S)	
EXPLODED	SP04	NAME PLATE	(SKW-530 / ONKYO)	1	231-W53001B-20		
EXPLODED	SP05	WOOD SCREW	Bind 4 x L75 (FOR FOOT)	4	411-BY4075AB1		
EXPLODED	SP06	WOOD SCREW	4STT + 20A (FOR AMP / SP)	16	837440204		
EXPLODED	SP07	SCREW	4 x 25 (FOR POWER TRANSFORMER)	4	412-D840250B1		
EXPLODED	SP08	WOOFER	10" 4 ohm 80W (ONKYO)	1	W2301B		
EXPLODED	SP09	LED HARNESS ASS'Y	---	1	335-SKW520-00		
EXPLODED	SP11	CUSHION RUBBER PAD	14 x 89 T2 RUBBER (FOR P-TRANS)	2	442-902123-00		
EXPLODED	SKF-530F (B) <L> / <R> : FRONT SPEAKERS						
EXPLODED	SKF-530F (S) <L> / <R> : FRONT SPEAKERS						
EXPLODED	SP21a	CABINET ASS'Y	SKF-530F (B) <L>	1	000-SKF530FBLSER	(B), <L>	
EXPLODED	SP21b	CABINET ASS'Y	SKF-530F (B) <R>	1	000-SKF530FBRSER	(B), <R>	
EXPLODED	SP21c	CABINET ASS'Y	SKF-530F (S) <L>	1	000-SKF530FSLSER	(S), <L>	
EXPLODED	SP21d	CABINET ASS'Y	SKF-530F (S) <R>	1	000-SKF530FSRSER	(S), <R>	
EXPLODED	SP22	CATCHING HOLDER	---	4	D230-DN3X01B-01		
EXPLODED	SP23	WOOFER	W1278A (ONKYO)	2	W1278A		
EXPLODED	SP24	TWEETER	---	1	302-D1F5300200		
EXPLODED	SP25	PANEL	---	1	D200-F53001S-10		
EXPLODED	SP26	SCREW	4/16 BIND 8.3ED	8	411-P84016AB2		
EXPLODED	SP27	SCREW	3.5/14 PAN, P, ED	4	411-P835140P2		
EXPLODED	SP28	S. ABSORBER	25T x 60 x 60	1	443-925402-00		
EXPLODED	SP29	CUSHION PANEL	1.5T x 73Dia. x 82Dia.	1	442-215102-00		
EXPLODED	SP30	CUSHION TW	4T x 50Dia x 74Dia.	1	442-904101-00		
EXPLODED	SP31	NETWORK ASS'Y	---	1	310-SKF530-01		
EXPLODED	SP32a	TERMINAL	WHITE / BLACK	1	332-LY104B-40	<L>	
EXPLODED	SP32b	TERMINAL	RED / BLACK	1	332-LY104B-00	<R>	

EXPLODED	SP33a	SPEC LABEL (L)	---	1	600-KF530L-01	<L>
EXPLODED	SP33b	SPEC LABEL (R)	---	1	600-KF530R-00	<R>
EXPLODED	SP34a	GRILLE ASS'Y	(WITH GRILLE CLOTH and LOGO)	1	D201-F53001B-90	(B)
EXPLODED	SP34b	GRILLE ASS'Y	(WITH GRILLE CLOTH and LOGO)	1	D201-F53001S-90	(S)
EXPLODED	SKC-530C (B) : CENTER SPEAKER					
EXPLODED	SKC-530C (S) : CENTER SPEAKER					
EXPLODED	SP41a	CABINET ASS'Y	SKC-530C (B)	1	000-SKC530CBSER	(B)
EXPLODED	SP41b	CABINET ASS'Y	SKC-530C (S)	1	000-SKC530SSER	(S)
EXPLODED	SP42	CATCHING HOLDER	---	4	D230-DN3X01B-01	
EXPLODED	SP43	WOOFER	W1278A (ONKYO)	2	W1278A	
EXPLODED	SP44	TWEETER	---	1	302-D1F5300200	
EXPLODED	SP45	PANEL	---	1	D200-F53001S-10	
EXPLODED	SP46	SCREW	4/16 BIND 8.3ED	8	411-P84016AB2	
EXPLODED	SP47	SCREW	3.5/14 PAN, P, ED	4	411-P835140P2	
EXPLODED	SP48	S. ABSORBER	25T x 60 x 60	1	443-925402-00	
EXPLODED	SP49	CUSHION PANEL	1.5T x 73Dia. x 82Dia.	1	442-215102-00	
EXPLODED	SP50	CUSHION TW	4T x 50Dia x 74Dia.	1	442-904101-00	
EXPLODED	SP51	NETWORK ASS'Y	---	1	310-SKF530-01	
EXPLODED	SP52	TERMINAL	GREEN / BLACK	1	332-LY104B-30	
EXPLODED	SP53	SPEC LABEL	---	1	600-SKC530-00	
EXPLODED	SP54a	GRILLE ASS'Y	(WITH GRILLE CLOTH and LOGO)	1	D201-C53001B-90	(B)
EXPLODED	SP54b	GRILLE ASS'Y	(WITH GRILLE CLOTH and LOGO)	1	D201-C53001S-90	(S)
EXPLODED	SKM-530S (B) <L> / <R> : SURROUND SPEAKERS					
EXPLODED	SKM-530S (S) <L> / <R> : SURROUND SPEAKERS					
EXPLODED	SP61a	COMPLETE UNIT	"SKM-530S (B) <L>"	1	000-SKM530SLB	(B), <L>
EXPLODED	SP61b	COMPLETE UNIT	"SKM-530S (S) <L>"	1	000-SKM520SSL	(S), <L>
EXPLODED	SP62	SPEC LABEL (L)	---	1	600-KM530L-00	<L>
EXPLODED	SP63a	COMPLETE UNIT	"SKM-530S (B) <R>"	1	000-SKM530SRB	(B), <R>
EXPLODED	SP63b	COMPLETE UNIT	"SKM-530S (S) <R>"	1	000-SKM520SSR	(S), <R>
EXPLODED	SP64	SPEC LABEL (R)	---	1	600-KM530R-00	<R>
EXPLODED	SKB-530 (B) <L> / <R> : SURROUND BACK SPEAKERS					
EXPLODED	SKB-530 (S) <L> / <R> : SURROUND BACK SPEAKERS					
EXPLODED	SP65a	COMPLETE UNIT	"SKB-530 (B) <L>"	1	000-SKB530BLB	(B), <L>
EXPLODED	SP65b	COMPLETE UNIT	"SKB-530 (S) <L>"	1	000-SKB530BLS	(S), <L>
EXPLODED	SP66	SPEC LABEL (L)	---	1	600-KB530L-00	<L>
EXPLODED	SP67a	COMPLETE UNIT	"SKB-530 (B) <R>"	1	000-SKB530BRB	(B), <R>
EXPLODED	SP67b	COMPLETE UNIT	"SKB-530 (S) <R>"	1	000-SKB530BRS	(S), <R>
EXPLODED	SP68	SPEC LABEL (R)	---	1	600-KB530R-00	<R>

HTP-530**PRINTED CIRCUIT BOARD PARTS LIST**

NOTE : THE COMPONENTS IDENTIFIED BY THE MARK
! ARE CRITICAL FOR RISK OF FIRE AND
ELECTRIC SHOCK. REPLACE ONLY WITH PART
NUMBER SPECIFIED.

<Notes>

<MDD> : MDD, MDC only

<MPA> : MPA only

SKW-530

U01	AMPLIFIER PC BOARD (NAAF-8275-1A / -1D)
U02	INPUT TERMINAL PC BOARD (NAETC-8276-1A / -1D)
U03	POWER TRANSFORMER PC BOARD (NAPS-8277-1A / -1D)

U04		THERMAL SENSOR PC BOARD (NAETC-8312-1A / -1D)				
U05		HOLDER PC BOARD (NAETC-8317-1A / -1D)				
CIRCUIT NO.	PART NAME	DESCRIPTION	Q'TY	PART NO. (SN)	REMARKS	
PWB	<Note>					
PWB	When replacement the following the transistor, made from the same HFE rank as the original type.					
PWB	Q301	IC		NJM4558L-D	1 22240293	
PWB	Q302	IC		NJM4558L-D	1 22240293	
PWB	Q601	IC		NJM4558L-D	1 22240293	
PWB	Q501	TR		KTC3200-BL	1 2215896	
PWB	Q501 or	TR		2SC1775A-E	(1) 2210755	
PWB	Q501 or	TR		2SC1775A-F	(1) 2210756	
PWB	Q502	TR		KTC3200-BL	1 2215896	
PWB	Q502 or	TR		2SC1775A-E	(1) 2210755	
PWB	Q502 or	TR		2SC1775A-F	(1) 2210756	
PWB	Q503	TR		2SC2240-BL	1 2211406	
PWB	Q504	TR		2SC2240-BL	1 2211406	
PWB	Q505	TR		KTA1024-Y	1 2215844	
PWB	Q505 or	TR		KTA1024-O	(1) 2215843	
PWB	Q505 or	TR		2SA949-Y	(1) 2211354	
PWB	Q505 or	TR		2SA949-O	(1) 2211353	
PWB	Q506	TR		KTC3206-Y	1 2215854	
PWB	Q506 or	TR		KTC3206-O	(1) 2215853	
PWB	Q506 or	TR		2SC2229-Y	(1) 2211634	
PWB	Q506 or	TR		2SC2229-O	(1) 2211633	
PWB	Q507	TR		KTA1024-Y	1 2215844	
PWB	Q507 or	TR		KTA1024-O	(1) 2215843	
PWB	Q507 or	TR		2SA949-Y	(1) 2211354	
PWB	Q507 or	TR		2SA949-O	(1) 2211353	
PWB	Q509	TR		KTA1024-Y	1 2215844	
PWB	Q509 or	TR		KTA1024-O	(1) 2215843	
PWB	Q509 or	TR		2SA949-Y	(1) 2211354	
PWB	Q509 or	TR		2SA949-O	(1) 2211353	
PWB	Q510	TR		KTC3206-Y	1 2215854	
PWB	Q510 or	TR		KTC3206-O	(1) 2215853	
PWB	Q510 or	TR		2SC2229-Y	(1) 2211634	
PWB	Q510 or	TR		2SC2229-O	(1) 2211633	
PWB	Q513	TR		KTD2061-Y	1 2203434	
PWB	Q513 or	TR		2SD1763-E	(1) 2201945	
PWB	Q513 or	TR		2SD1763A-D	(1) 2202034	
PWB	Q513 or	TR		2SC5171	(1) 2203010	
PWB	Q514	TR		KTB1369-Y	1 2203424	
PWB	Q514 or	TR		2SB1186-E	(1) 2201935	
PWB	Q514 or	TR		2SB1186A-D	(1) 2202024	
PWB	Q514 or	TR		2SA1930	(1) 2203000	
PWB	Q517	TR		2SA933S-S	1 2213355	
PWB	Q517 or	TR		2SA933S-R	(1) 2213354	
PWB	Q517 or	TR		KTA1267-GR	(1) 2215995	
PWB	Q518	TR		2SC2235-Y	1 2211654	
PWB	Q519	TR		2SA965-Y	1 2211644	
PWB	Q602	TR		KRC103M	1 2215810	
PWB	Q602 or	TR		DTC124ES	(1) 2213160	

PWB	Q603	TR	2SC1740S-S	1	2213285
PWB	Q603 or	TR	2SC1740S-R	(1)	2213284
PWB	Q603 or	TR	KTC3199-GR	(1)	2215864
PWB	Q604	TR	2SA933S-S	1	2213355
PWB	Q604 or	TR	2SA933S-R	(1)	2213354
PWB	Q604 or	TR	KTA1267-GR	(1)	2215995
PWB	Q605	TR	2SA933S-S	1	2213355
PWB	Q605 or	TR	2SA933S-R	(1)	2213354
PWB	Q605 or	TR	KTA1267-GR	(1)	2215995
PWB	Q606	TR	KRA103M	1	2215780
PWB	Q606 or	TR	DTA124ES	(1)	2212600
PWB	Q606 or	TR	RN2203	(1)	2213580
PWB	Q607	TR	2SA933S-S	1	2213355
PWB	Q607 or	TR	2SA933S-R	(1)	2213354
PWB	Q607 or	TR	KTA1267-GR	(1)	2215995
PWB	Q608	TR	2SC1740S-S	1	2213285
PWB	Q608 or	TR	2SC1740S-R	(1)	2213284
PWB	Q608 or	TR	KTC3199-GR	(1)	2215864
PWB	Q609	TR	2SC1740S-S	1	2213285
PWB	Q609 or	TR	2SC1740S-R	(1)	2213284
PWB	Q609 or	TR	KTC3199-GR	(1)	2215864
PWB	D601	ZENER D	MTZJ2.7B	1	224470272
PWB	D601 or	ZENER D	DZ-2.7BSB	(1)	224850272
PWB	D602	ZENER D	MTZJ2.7B	1	224470272
PWB	D602 or	ZENER D	DZ-2.7BSB	(1)	224850272
PWB	D603	DIODE	1SS133	1	223163
PWB	D603 or	DIODE	1SS270A	(1)	223205
PWB	D603 or	DIODE	1SS133(DS)	(1)	223280
PWB	D604	DIODE	1SS133	1	223163
PWB	D604 or	DIODE	1SS270A	(1)	223205
PWB	D604 or	DIODE	1SS133(DS)	(1)	223280
PWB	D605	DIODE	1SS133	1	223163
PWB	D605 or	DIODE	1SS270A	(1)	223205
PWB	D605 or	DIODE	1SS133(DS)	(1)	223280
PWB	D606	DIODE	1SS133	1	223163
PWB	D606 or	DIODE	1SS270A	(1)	223205
PWB	D606 or	DIODE	1SS133(DS)	(1)	223280
PWB	D651	DIODE	1SS133	1	223163
PWB	D651 or	DIODE	1SS270A	(1)	223205
PWB	D651 or	DIODE	1SS133(DS)	(1)	223280
PWB	D901	DIODE	RS404L	1	22380277
PWB	D902	DIODE	RL1N4003	1	22380260
PWB	D902 or	DIODE	GP104003E	(1)	22380035
PWB	D903	DIODE	RL1N4003	1	22380260
PWB	D903 or	DIODE	GP104003E	(1)	22380035
PWB	D904	ZENER D	MTZJ5.6B	1	224470562
PWB	D904 or	ZENER D	DZ-5.6BSB	(1)	224850562
PWB	D951	ZENER D	MTZJ15C	1	224471503
PWB	D951 or	ZENER D	DZ-15BSC	(1)	224851503
PWB	D952	ZENER D	MTZJ15C	1	224471503
PWB	D952 or	ZENER D	DZ-15BSC	(1)	224851503

PWB	C301	VX C	CE04W50V-47M(VX)	1	393384707	
PWB	C302	TF C	ECQ-B50V-101K	1	374721015	
PWB	C303	VX C	CE04W50V-47M(VX)	1	393384707	
PWB	C304	TF C	ECQ-V50V-104J	1	374721044	
PWB	C305	TF C	ECQ-V50V-104J	1	374721044	
PWB	C306	TF C	ECQ-V50V-104J	1	374721044	
PWB	C307	TF C	ECQ-V50V-104J	1	374721044	
PWB	C308	VX C	CE04W50V-47M(VX)	1	393384707	
PWB	C501	VX C	CE04W50V-0.47M(VX)	1	393384797	
PWB	C502	TF C	ECQ-B50V-151K	1	374721515	
PWB	C503	TF C	ECQ-B50V-151K	1	374721515	
PWB	C504	VX C	CE04W16V-220M(VX)	1	393342217	
PWB	C505	CERA C	CC45CH50V-020C	1	345340201	
PWB	C506	CERA C	CC45CH50V-070D	1	345340702	
PWB	C517	VX C	CE04W50V-10M(VX)	1	393381007	
PWB	C519	TF C	ECQ-V50V-224J	1	374722244	
PWB	C520	TF C	ECQ-V50V-224J	1	374722244	
PWB	C526	VX C	CE04W50V-10M(VX)	1	393381007	
PWB	C527	VX C	CE04W16V-220M(VX)	1	393342217	
PWB	C528	VX C	CE04W50V-10M(VX)	1	393381007	
PWB	C601	VR C	CE04W50V-10M(VR)	1	394681007	
PWB	C602	VR C	CE04W50V-10M(VR)	1	394681007	
PWB	C603	VR C	CE04W10V-470M(VR)	1	394634717	
PWB	C603 or	VX C	CE04W16V-470M(VX)	(1)	393344717	
PWB	C604	VR C	CE04W35V-33M(VR)	1	394663307	
PWB	C604 or	ELECT C	CE04W35V-33M	(1)	354763309	
PWB	C901	IS C	DE1310E472M-KH	1	3300054	!
PWB	C901A	C COVER	SB1925A	1	27301216	!
PWB	C903	TF C	ECQ-V100-104J	1	374731044	
PWB	C904	TF C	ECQ-V100-104J	1	374731044	
PWB	C905	ELECT C	CE62W63V-5600M	1	3504399	
PWB	C905 or	ELECT C	CE62W63V-5600M	(1)	3504411	
PWB	C906	ELECT C	CE62W63V-5600M	1	3504399	
PWB	C906 or	ELECT C	CE62W63V-5600M	(1)	3504411	
PWB	C909	VR C	CE04W50V-22M(VR)	1	394682207	
PWB	C933	TF C	ECQ-V50V-104J	1	374721044	
PWB	C934	TF C	ECQ-V50V-104J	1	374721044	
PWB	C950	TF C	ECQ-V50V-104J	1	374721044	
PWB	C951	VR C	CE04W16V-220M(VR)	1	394642217	
PWB	C952	VR C	CE04W16V-220M(VR)	1	394642217	
PWB	C953	VR C	CE04W16V-220M(VR)	1	394642217	
PWB	C954	VR C	CE04W16V-220M(VR)	1	394642217	
PWB	C955	TF C	ECQ-B50V-223J	1	374722234	
PWB	R104	VARI R	N17RGL20KB15M	1	5151508	
PWB	R301	CARBON R	R16J-1K	1	417341024	
PWB	R302	CARBON R	R16J-1M	1	417341054	
PWB	R303	CARBON R	R16J-100K	1	417341044	
PWB	R304	CARBON R	R16J-18K	1	417341834	
PWB	R305	CARBON R	R16J-33K	1	417343334	
PWB	R306	CARBON R	R16J-4.7K	1	417344724	
PWB	R307	CARBON R	R16J-100K	1	417341044	

PWB	R308	CARBON R	R16J-47K	1	417344734	
PWB	R311	CARBON R	R16J-5.6K	1	417345624	
PWB	R312	CARBON R	R16J-5.6K	1	417345624	
PWB	R313	CARBON R	R16J-5.6K	1	417345624	
PWB	R314	CARBON R	R16J-5.6K	1	417345624	
PWB	R315	CARBON R	R16J-100K	1	417341044	
PWB	R316	CARBON R	R16J-1K	1	417341024	
PWB	R501	CARBON R	R16J-1K	1	417341024	
PWB	R502	CARBON R	R16J-47K	1	417344734	
PWB	R503	CARBON R	R16J-5.6K	1	417345624	
PWB	R504	CARBON R	R16J-270	1	417342714	
PWB	R505	NF CARBON R	R25J-1.0K	1	415471024	!
PWB	R506	NF CARBON R	R25J-1.0K	1	415471024	!
PWB	R507	CARBON R	R16J-33K	1	417343334	
PWB	R508	NF CARBON R	R25J-47	1	415474704	!
PWB	R509	CARBON R	R16J-1K	1	417341024	
PWB	R510	CARBON R	R16J-100K	1	417341044	
PWB	R511	NF CARBON R	R25J-82	1	415478204	!
PWB	R512	NF CARBON R	R25J-68	1	415476804	!
PWB	R513	NF CARBON R	R25J-82	1	415478204	!
PWB	R514	NF CARBON R	R25J-82	1	415478204	!
PWB	R515	CARBON R	R16J-12K	1	417341234	
PWB	R516	CARBON R	R16J-12K	1	417341234	
PWB	R517	CARBON R	R16J-3.3K	1	417343324	
PWB	R521	CARBON R	R16J-220	1	417342214	
PWB	R522	CARBON R	R16J-220	1	417342214	
PWB	R526	METAL O R	RS1/2WBJ-150	1	443521514	
PWB	R527	CARBON R	R16J-270	1	417342714	
PWB	R528	METAL O R	RS1/2WBJ-390	1	443523914	
PWB	R531	METAL PR	RF-5EGKR22	1	4000201	
PWB	R531 or	METAL P R	RGC55C 0.22 K	(1)	4000157	
PWB	R533	METAL R	RNU1WCJ-3.3	1	453630334	
PWB	R534	CARBON R	R16J-100	1	417341014	
PWB	R541	CARBON R	R16J-820	1	417348214	
PWB	R542	CARBON R	R16J-150	1	417341514	
PWB	R543	CARBON R	R16J-100	1	417341014	
PWB	R544	TRIM R	N06HR100BC	1	5210359	
PWB	R601	CARBON R	R16J-5.6K	1	417345624	
PWB	R602	CARBON R	R16J-100K	1	417341044	
PWB	R603	CARBON R	R16J-150K	1	417341544	
PWB	R604	CARBON R	R16J-180	1	417341814	
PWB	R605	CARBON R	R16J-10K	1	417341034	
PWB	R606	CARBON R	R16J-10K	1	417341034	
PWB	R607	CARBON R	R16J-22	1	417342204	
PWB	R608	CARBON R	R16J-22	1	417342204	
PWB	R609	CARBON R	R16J-39K	1	417343934	
PWB	R610	CARBON R	R16J-560K	1	417345644	
PWB	R611	CARBON R	R16J-820K	1	417348244	
PWB	R612	CARBON R	R16J-39K	1	417343934	
PWB	R613	CARBON R	R16J-470K	1	417344744	
PWB	R614	CARBON R	R16J-120K	1	417341244	

PWB	R615	CARBON R	R16J-22K	1	417342234	
PWB	R616	CARBON R	R16J-100K	1	417341044	
PWB	R617	CARBON R	R16J-1K	1	417341024	
PWB	R619	CARBON R	R16J-22K	1	417342234	
PWB	R620	CARBON R	R16J-100K	1	417341044	
PWB	R621	CARBON R	R16J-1K	1	417341024	
PWB	R622	CARBON R	R16J-10K	1	417341034	
PWB	R623	CARBON R	R16J-100K	1	417341044	
PWB	R624	CARBON R	R16J-100K	1	417341044	
PWB	R625	CARBON R	R16J-180K	1	417341844	
PWB	R626	CARBON R	R16J-2.2M	1	417342254	
PWB	R627	CARBON R	R16J-680K	1	417346844	
PWB	R628	CARBON R	R16J-330K	1	417343344	
PWB	R629	CARBON R	R16J-22K	1	417342234	
PWB	R651	METAL O R	RS1/2WBJ-12K	1	443521234	
PWB	R701	RESISTOR	PTFL04BC222(100)	1	4000230	
PWB	R901	METAL O R	RS1WBJ-820	1	443628214	
PWB	R902	METAL O R	RS1WBJ-820	1	443628214	
PWB	R903	CARBON R	R16J-10K	1	417341034	
PWB	R904	METAL O R	RS1/2WBJ-1K	1	443521024	
PWB	R951	NF CARBON R	R25J-82	1	415478204	
PWB	R952	NF CARBON R	R25J-82	1	415478204	
PWB	R953	METAL O R	RS1/2WBJ-6.8K	1	443526824	
PWB	R954	METAL O R	RS1/2WBJ-6.8K	1	443526824	
PWB	R971	CARBON R	R16J-10K	1	417341034	
PWB	R972	CARBON R	R16J-47K	1	417344734	
PWB	F901A	FUSE HOL	NSCT-1P2506	1	25052609	!
PWB	F901A or	FUSE HOL	NSCT-1P2031	(1)	25052133	!
PWB	F901B	FUSE HOL	NSCT-1P2506	1	25052609	!
PWB	F901B or	FUSE HOL	NSCT-1P2031	(1)	25052133	!
PWB	F901C	LABEL	T2.5AL250V	1	29361747	<MPA>
PWB	JL535A	SOCKET AS	NSAS-2P1335	1	2009990876UL	
PWB	JL601	JUMPER LEAD	JL3 120 H	1	---	
PWB	JL601A	WIRE HOL	NSCT-3P894	1	25051107	
PWB	JL601B	WIRE HOL	NSCT-3P894	1	25051107	
PWB	P101	PIN JACK	NPJ-1PDB581	1	25045801	
PWB	P301B	PLUG	NPLG-5P133	1	25055149	
PWB	P302A	SOCKET AS	NSAS-10P0798	1	2009990587UL	
PWB	P531	PLUG	NPLG-2P29	1	25055038	
PWB	P631	PLUG	NPLG-2P29	1	25055038	
PWB	P632A	PLUG	NPLG-3P131	1	25055147	
PWB	P901A	PLUG	NPLG-3P150	1	25055166	
PWB	P901B	SOCKET AS	NSAS-6P1536	1	2009990969UL	<MDD>
PWB	P901B	SOCKET AS	NSAS-6P1333	1	2009990874UL	<MPA>
PWB	P902A	PLUG	NPLG-2P632	1	25055676	!
PWB	E701	SHLD CASE	(THERMISTOR)	1	27225154A	
PWB	E810	RETAINER	KANAGU (EARTH)	1	27141059	

ONKYO CORPORATION

Sales & Product Planning Div. : 2-1, Nisshin-cho, Neyagawa-shi, OSAKA 572-8540, JAPAN
Tel: 072-831-8023 Fax: 072-831-8124

ONKYO U.S.A. CORPORATION

18 Park Way, Upper Saddle River, N.J. 07458, U.S.A.
Tel: 201-785-2600 Fax: 201-785-2650 <http://www.us.onkyo.com/>

ONKYO EUROPE ELECTRONICS GmbH

Liegnitzerstrasse 6, 82194 Groebenzell, GERMANY
Tel: +49-8142-4401-0 Fax: +49-8142-4401-555 <http://www.eu.onkyo.com/>

ONKYO EUROPE UK Office

Suite 1, Gregories Court, Gregories Road, Beaconsfield, Buckinghamshire, HP9 1HQ
UNITED KINGDOM Tel: +44-(0)1494-681515 Fax: +44(0)-1494-680452

ONKYO CHINA LIMITED

Units 2102-2107, Metroplaza Tower I, 223 Hing Fong Road, Kwai Chung,
N.T., HONG KONG Tel: 852-2429-3118 Fax: 852-2428-9039
<http://www.ch.onkyo.com/>

