

ONKYO SERVICE MANUAL

7.1-CH HOME THEATER SPEAKER PACKAGE MODEL HTP-740(B)

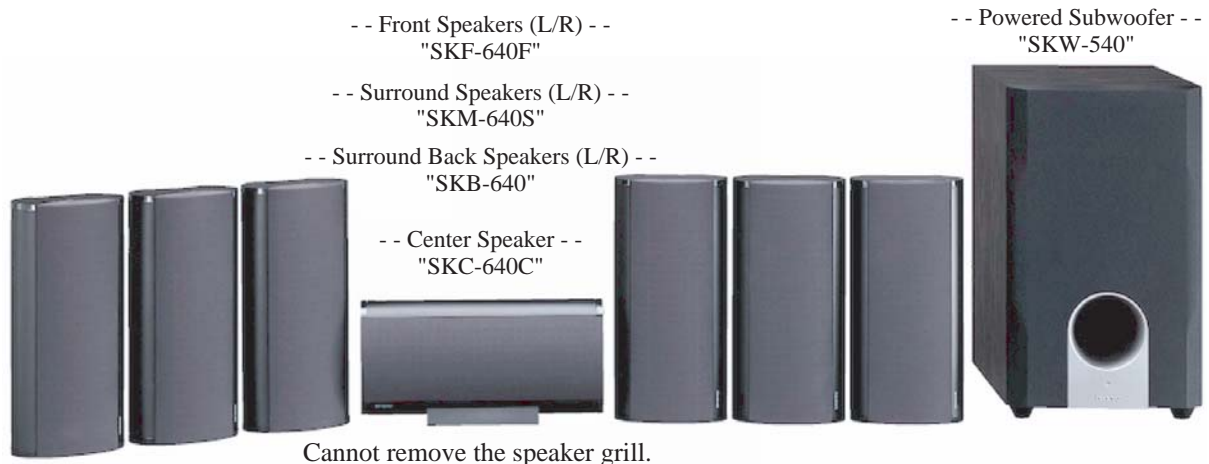

Black model

B MDD	120V AC, 60Hz
-------	---------------

SAFETY-RELATED COMPONENT WARNING!!

COMPONENTS IDENTIFIED BY MARK \triangle ON THE SCHEMATIC DIAGRAM AND IN THE PARTS LIST ARE CRITICAL FOR RISK OF FIRE AND ELECTRIC SHOCK. REPLACE THESE COMPONENTS WITH ONKYO PARTS WHOSE PART NUMBERS APPEAR AS SHOWN IN THIS MANUAL.

MAKE LEAKAGE-CURRENT OR RESISTANCE MEASUREMENTS TO DETERMINE THAT EXPOSED PARTS ARE ACCEPTABLY INSULATED FROM THE SUPPLY CIRCUIT BEFORE RETURNING THE APPLIANCE TO THE CUSTOMER.

EXPLODED VIEW

SKF-640F / SKC-640C / SKM-640S / SKB-640

<Note>

SKW-540 ----> Refer to service manual of "SKS-HT540" (Ref. No. 3942-R1)

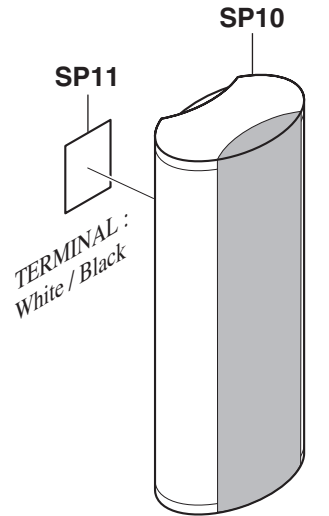

"SKF-640F <L>"

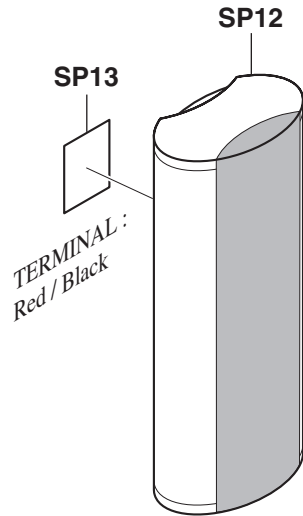

"SKF-640F <R>"

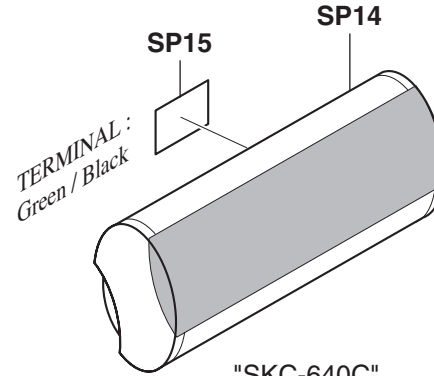

"SKC-640C"

<Note>

Cannot remove the speaker grill.

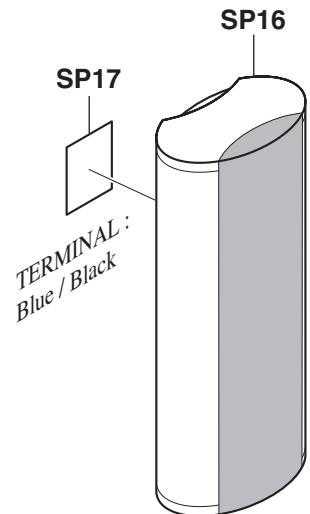

"SKM-640S <L>"

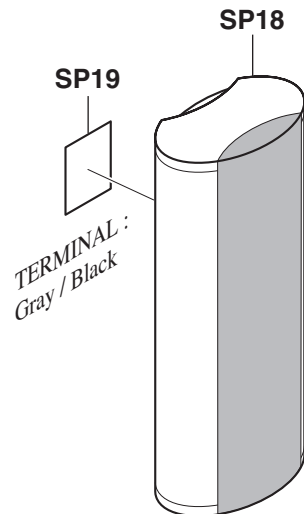

"SKM-640S <R>"

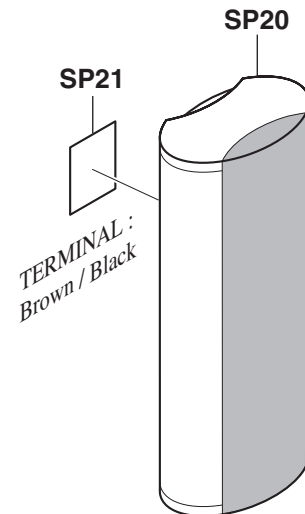

"SKB-640 <L>"

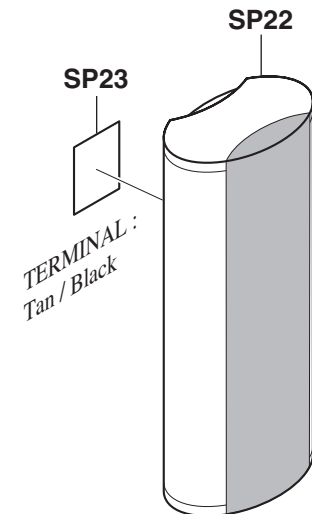

"SKB-640 <R>"

HTP-740

EXPLODED VIEW PARTS LIST

	REF. NO.	PART NAME	DESCRIPTION	Q'TY	PART NO. (SN)	REMARKS
EXPLODED	SKF-640F (B) <L> / <R> : FRONT SPEAKERS					
EXPLODED	SP10	COMPLETE UNIT	"SKF-640F (B) <L>"	1	000-SKF640FLBSER	
EXPLODED	SP11	SPEC LABEL (L)	---	1	600-P640FL-00	
EXPLODED	SP12	COMPLETE UNIT	"SKF-640F (B) <R>"	1	000-SKF640FRBSER	
EXPLODED	SP13	SPEC LABEL (R)	---	1	600-P640FR-00	
EXPLODED	SKC-640C (B) : CENTER SPEAKER					
EXPLODED	SP14	COMPLETE UNIT	"SKC-640C (B)"	1	000-SKC640CBSER	
EXPLODED	SP15	SPEC LABEL	---	1	600-P6400C-00	
EXPLODED	SKM-640S (B) <L> / <R> : SURROUND SPEAKERS					
EXPLODED	SP16	COMPLETE UNIT	"SKM-640S (B) <L>"	1	000-SKM640SLBSER	
EXPLODED	SP17	SPEC LABEL (L)	---	1	600-P640SL-00	
EXPLODED	SP18	COMPLETE UNIT	"SKM-640S (B) <R>"	1	000-SKM640SRBSER	
EXPLODED	SP19	SPEC LABEL (R)	---	1	600-P640SR-00	
EXPLODED	SKB-640 (B) <L> / <R> : SURROUND BACK SPEAKERS					
EXPLODED	SP20	COMPLETE UNIT	"SKB-640 (B) <L>"	1	000-SKB640SBLBSER	
EXPLODED	SP21	SPEC LABEL (L)	---	1	600-P640BL-00	
EXPLODED	SP22	COMPLETE UNIT	"SKB-640 (B) <R>"	1	000-SKB640SBRBSER	
EXPLODED	SP23	SPEC LABEL (R)	---	1	600-P640BR-00	
EXPLODED	<Note>					
EXPLODED	SKW-540 ---> Refer to service manual of "SKS-HT540" (Ref. No. 3942-R1).					

ONKYO CORPORATION

Sales & Product Planning Div. : 2-1, Nisshin-cho, Neyagawa-shi, OSAKA 572-8540, JAPAN
Tel: 072-831-8023 Fax: 072-831-8124

ONKYO U.S.A. CORPORATION

18 Park Way, Upper Saddle River, N.J. 07458, U.S.A.
Tel: 201-785-2600 Fax: 201-785-2650 <http://www.us.onkyo.com/>

ONKYO EUROPE ELECTRONICS GmbH

Liegnitzerstrasse 6, 82194 Groebenzell, GERMANY
Tel: +49-8142-4401-0 Fax: +49-8142-4401-555 <http://www.eu.onkyo.com/>

ONKYO EUROPE UK Office

Suite 1, Gregories Court, Gregories Road, Beaconsfield, Buckinghamshire, HP9 1HQ
UNITED KINGDOM Tel: +44-(0)1494-681515 Fax: +44(0)-1494-680452

ONKYO CHINA LIMITED

Units 2102-2107, Metroplaza Tower I, 223 Hing Fong Road, Kwai Chung,
N.T., HONG KONG Tel: 852-2429-3118 Fax: 852-2428-9039
<http://www.ch.onkyo.com/>

