

# ONKYO SERVICE MANUAL

## 6.1-CH HOME THEATER SPEAKER PACKAGE MODEL HTP-820(S)

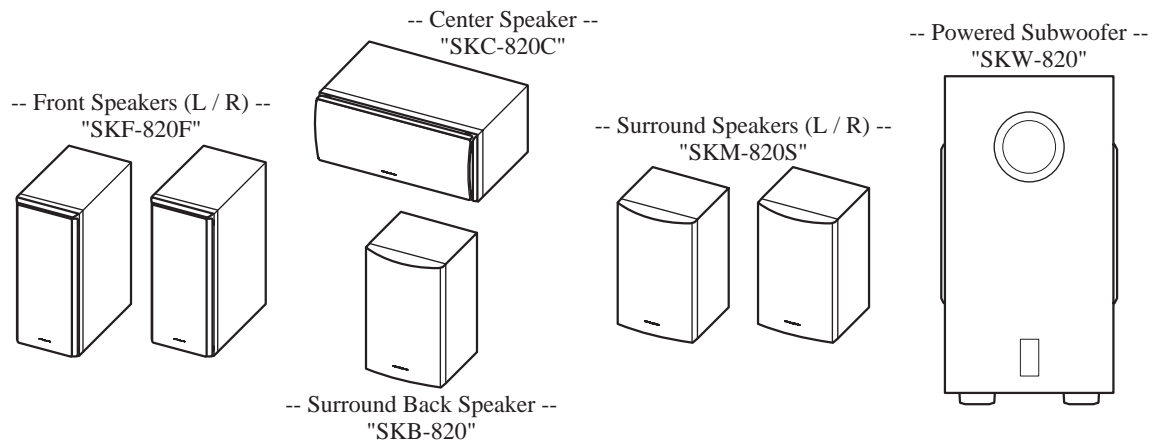

### Silver model

SMDC	120V AC, 60Hz
------	---------------

### SAFETY-RELATED COMPONENT WARNING!!

COMPONENTS IDENTIFIED BY MARK  ON THE SCHEMATIC DIAGRAM AND IN THE PARTS LIST ARE CRITICAL FOR RISK OF FIRE AND ELECTRIC SHOCK. REPLACE THESE COMPONENTS WITH ONKYO PARTS WHOSE PART NUMBERS APPEAR AS SHOWN IN THIS MANUAL.

MAKE LEAKAGE-CURRENT OR RESISTANCE MEASUREMENTS TO DETERMINE THAT EXPOSED PARTS ARE ACCEPTABLY INSULATED FROM THE SUPPLY CIRCUIT BEFORE RETURNING THE APPLIANCE TO THE CUSTOMER.

## SPECIFICATIONS

### ■ Powered Subwoofer (SKW-820)

Type :	Bass-reflex
Input sensitivity/impedance :	300 mV / 100 kohm
Maximum output power :	220 W (Dynamic Power)
Frequency response :	23 Hz - 150 Hz
Cabinet capacity :	1.59 cubic feet (44.9 L)
Dimensions (W x H x D) :	11-5/16" x 21-1/8" x 16-3/16" (287 x 536 x 411 mm)
Weight :	43.3 lbs. (19.7 kg)
Drivers unit :	8 inch (20 cm) Cone Woofer x 2
Power supply :	AC 120 V, 60 Hz
Power consumption :	170 W
Other :	Auto Standby function

### ■ Center Speaker (SKC-820C)

Type :	2 Way Bass-reflex
Impedance :	8 ohm
Maximum input power :	130 W
Output sound pressure level :	85 dB/W/m
Frequency response :	60 Hz - 45 kHz
Crossover frequency :	5 kHz
Cabinet capacity :	0.27 cubic feet (7.7 L)
Dimensions (W x H x D) :	15-1/4" x 6-3/16" x 7-15/16" (387 x 157 x 202 mm)
Weight :	9.5 lbs. (4.3 kg)
Drivers unit :	4 inch (10 cm) A-OMF Cone Woofer x 2 1 inch (2.5 cm) Soft Dome tweeter
Terminal :	Color-coded binding post
Other :	Magnetic shielding

### ■ Front Speaker (SKF-820F)

Type :	2 Way Bass-reflex
Impedance :	8 ohm
Maximum input power :	130 W
Output sound pressure level :	86 dB/W/m
Frequency response :	50 Hz - 45 kHz
Crossover frequency :	5 kHz
Cabinet capacity :	0.38 cubic feet (10.8 L)
Dimensions (W x H x D) :	7-7/16" x 16-1/2" x 9-5/16" (189 x 419 x 236 mm)
Weight :	13.7 lbs. (6.2 kg)
Drivers unit :	5-1/4 inch (13 cm) A-OMF Cone Woofer x 2 1 inch (2.5 cm) Soft Dome tweeter
Terminal :	Color-coded binding post
Other :	Magnetic shielding

### ■ Surround Speaker (SKM-820S/SKB-820)

Type :	2 Way Bass-reflex
Impedance :	8 ohm
Maximum input power :	130 W
Output sound pressure level :	82 dB/W/m
Frequency response :	60 Hz - 50 kHz
Crossover frequency :	5 kHz
Cabinet capacity :	0.09 cubic feet (2.7 L)
Dimensions (W x H x D) :	6-7/8" x 10-7/16" x 4-15/16" (175 x 265 x 125 mm)
Weight :	3.7 lbs. (1.7 kg)
Drivers unit :	4 inch (10 cm) Cone Woofer 1 inch (2.5 cm) Balanced Dome tweeter
Terminal :	Color-coded binding post

Specifications and appearance are subject to change without prior notice.

**EXPLODED VIEWS-1**  
**SKW-820 : POWERED SUBWOOFER**

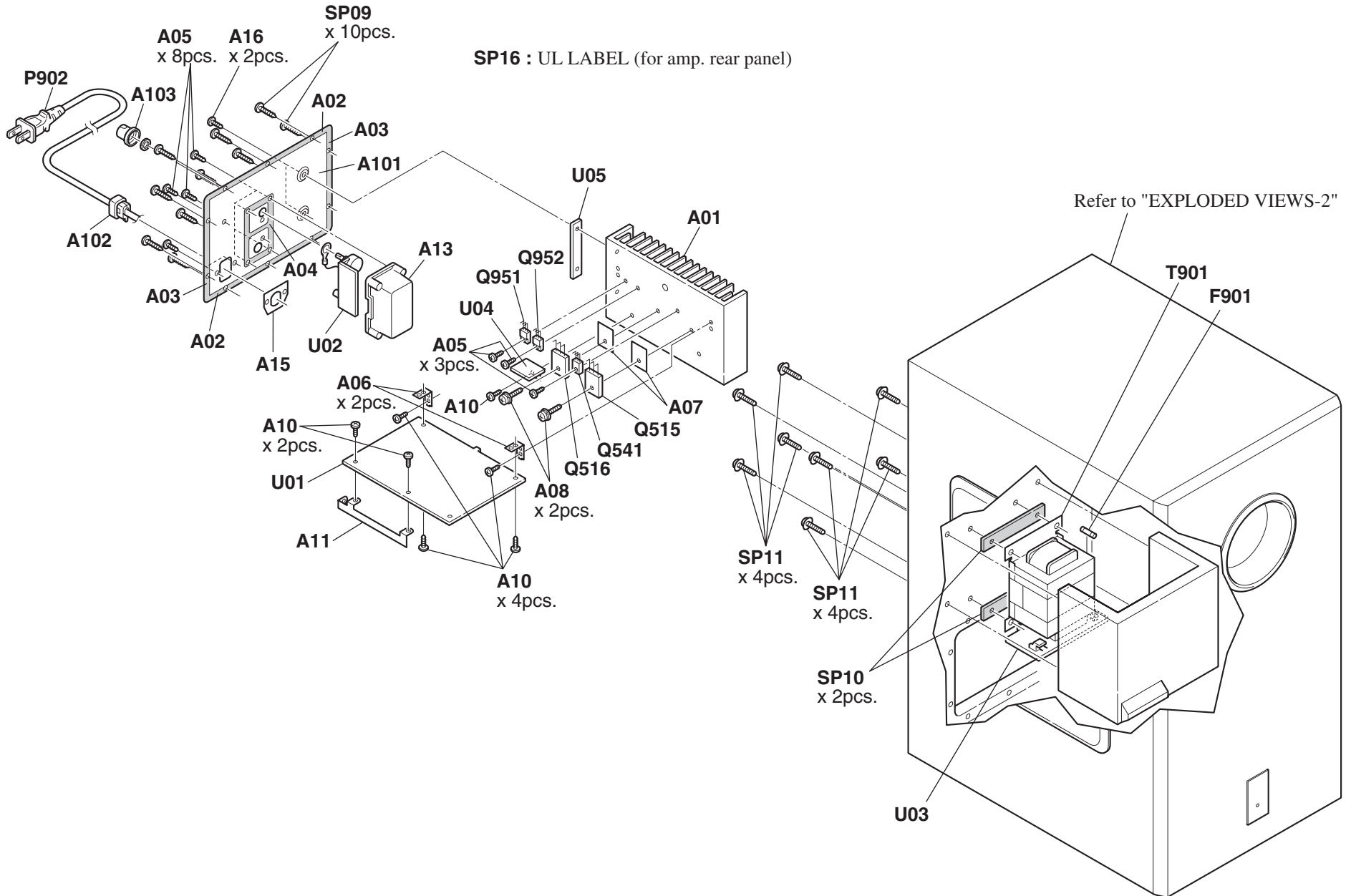

# EXPLODED VIEWS-2

## SKW-820 : POWERED SUBWOOFER

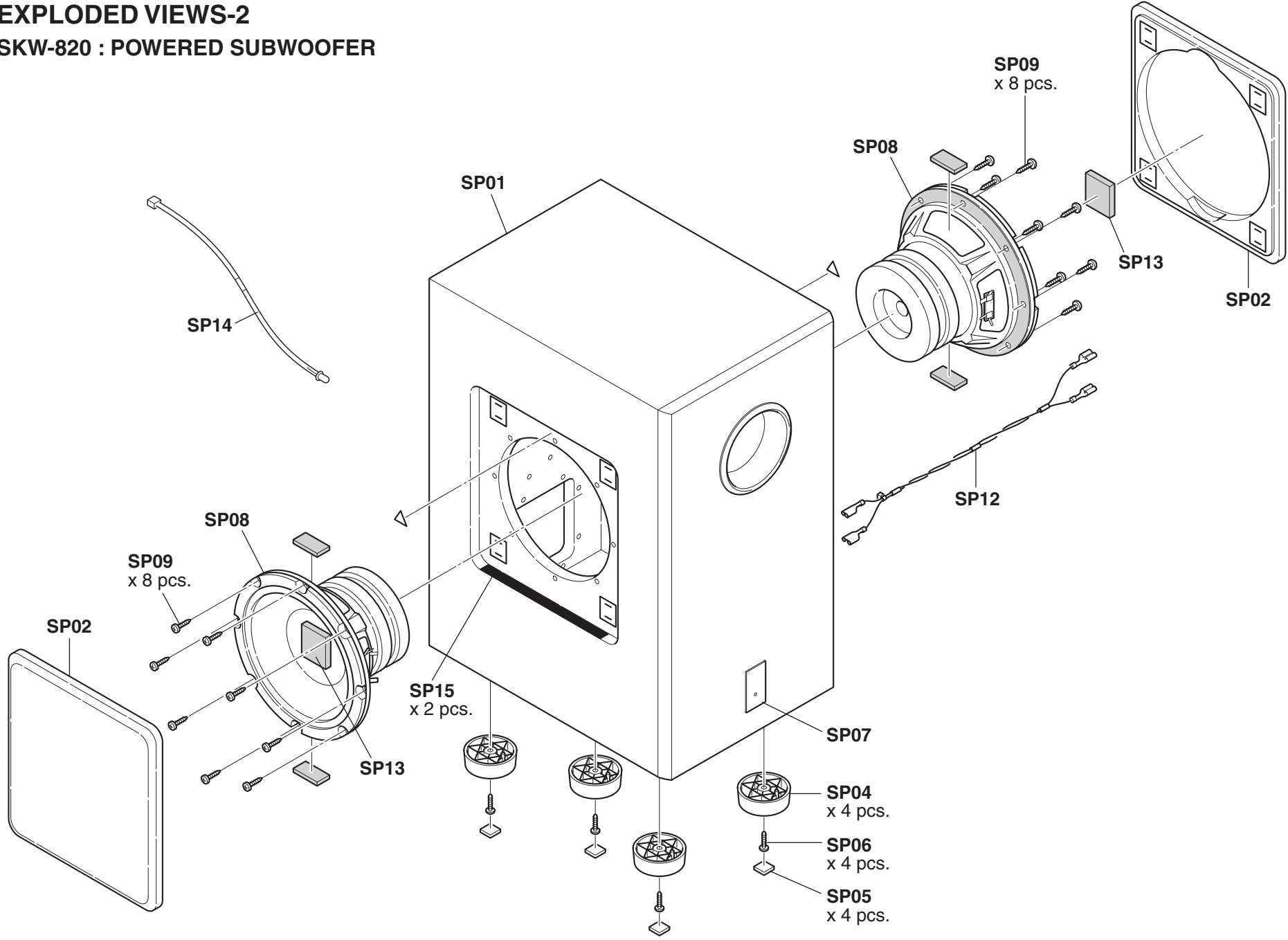

**EXPLODED VIEWS-3**

**SKF-820F <L> / SKF-820F <R>**

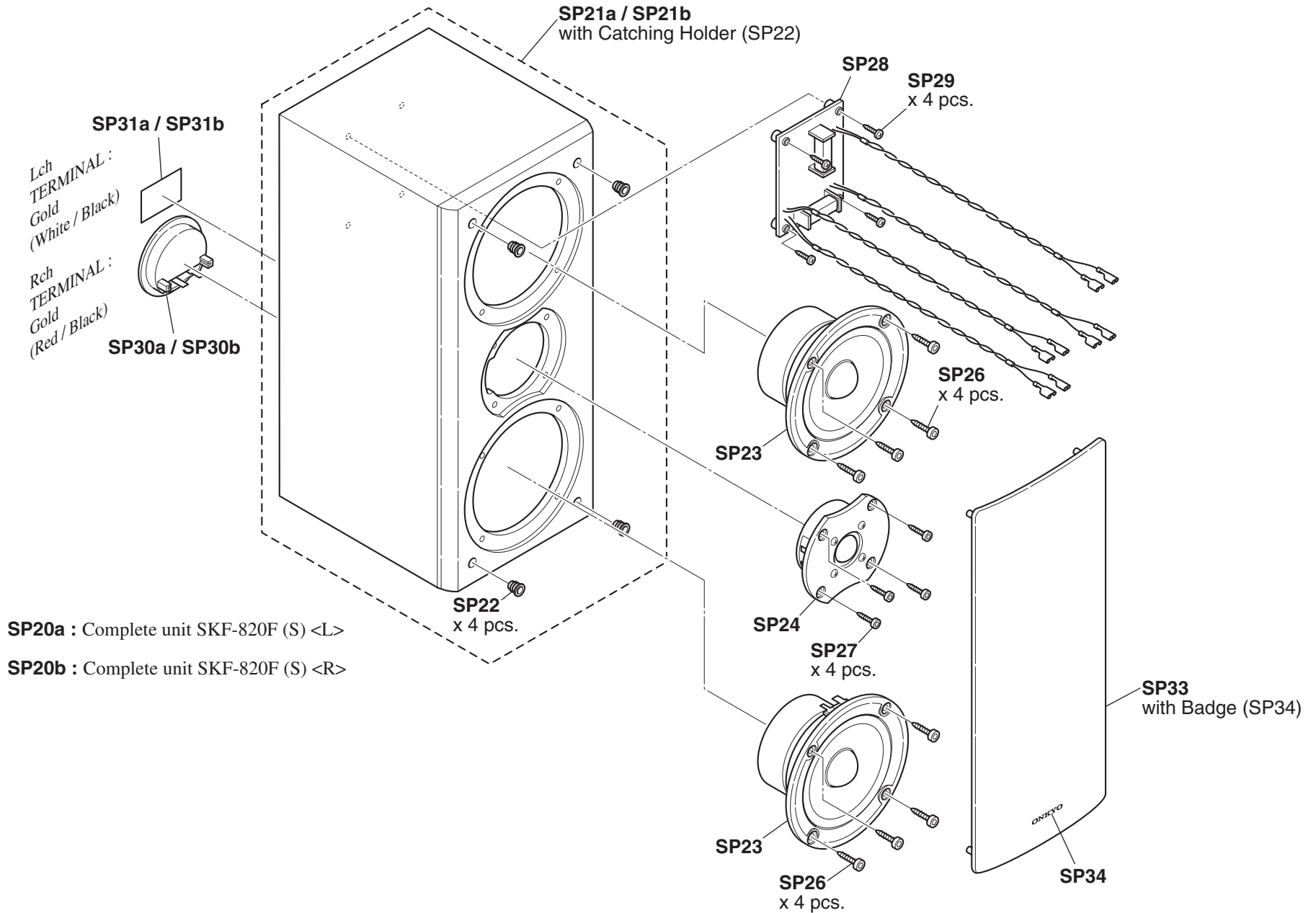

**SP20a** : Complete unit SKF-820F (S) <L>

**SP20b** : Complete unit SKF-820F (S) <R>

# EXPLODED VIEWS-4

## SKC-820C

SP40 : Complete unit SKC-820C (S)

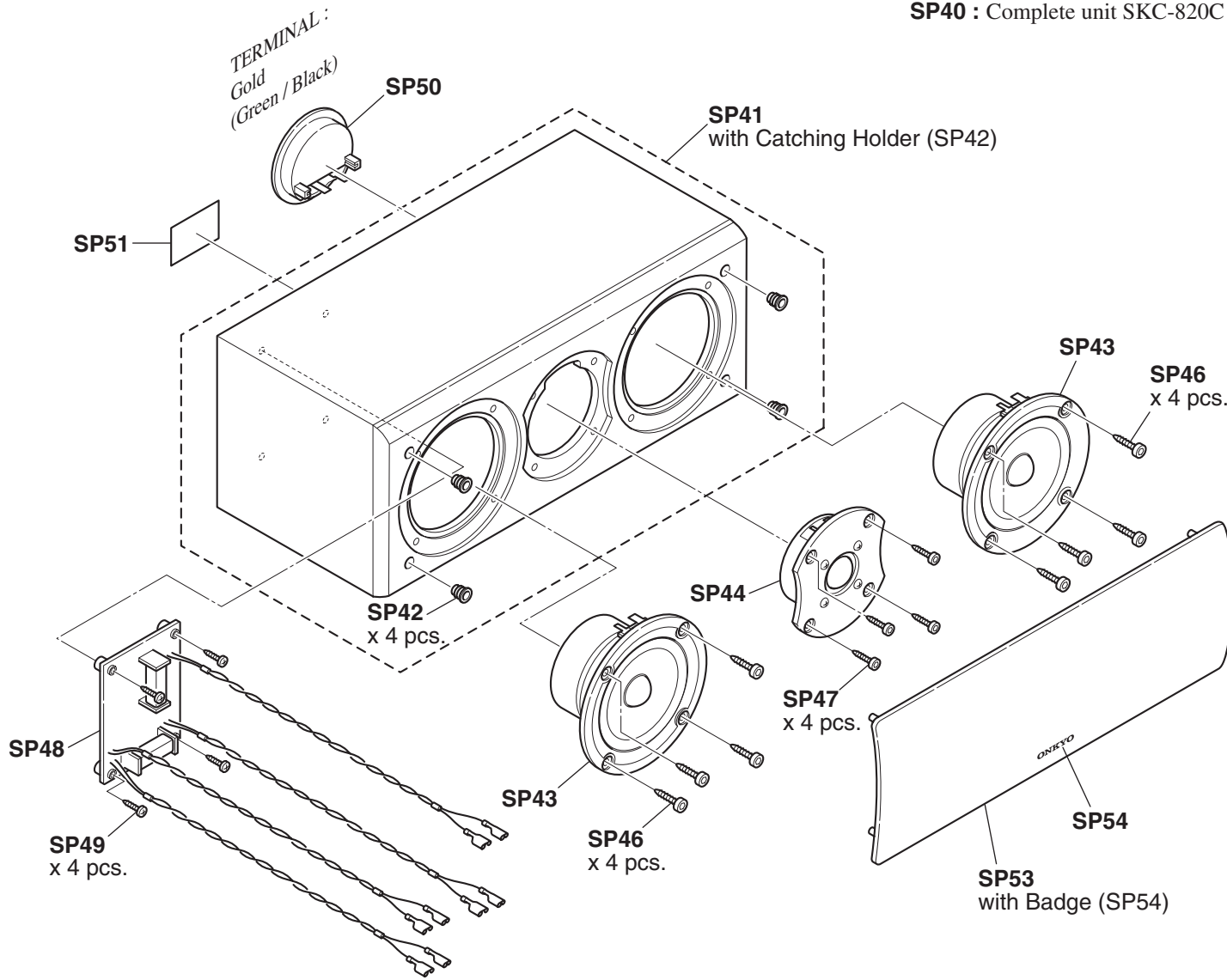

### EXPLODED VIEWS-5

SKM-820S <L> / SKM-820S <R> / SKB-820

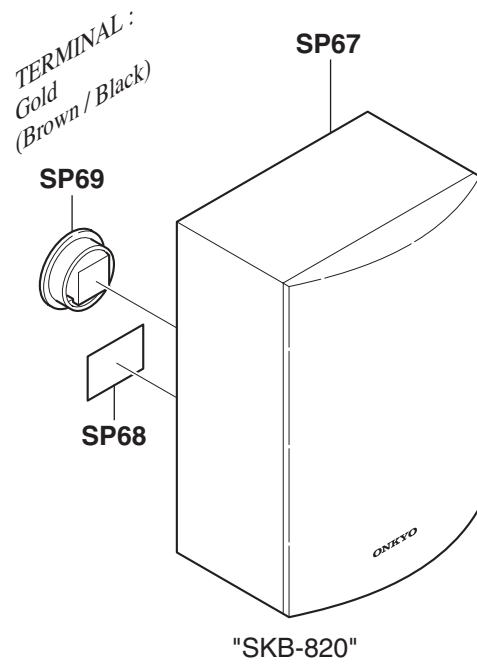
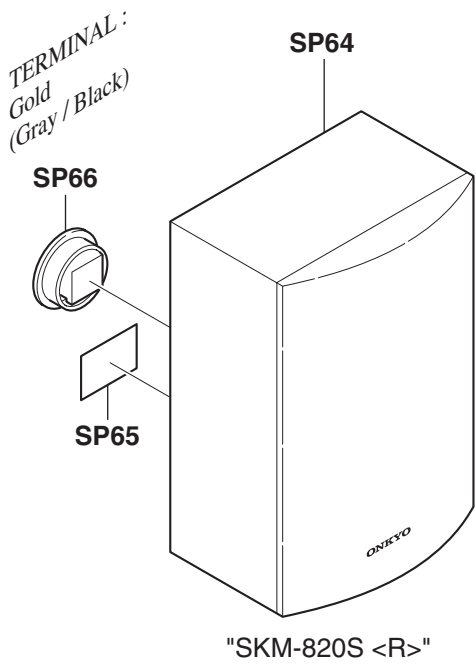
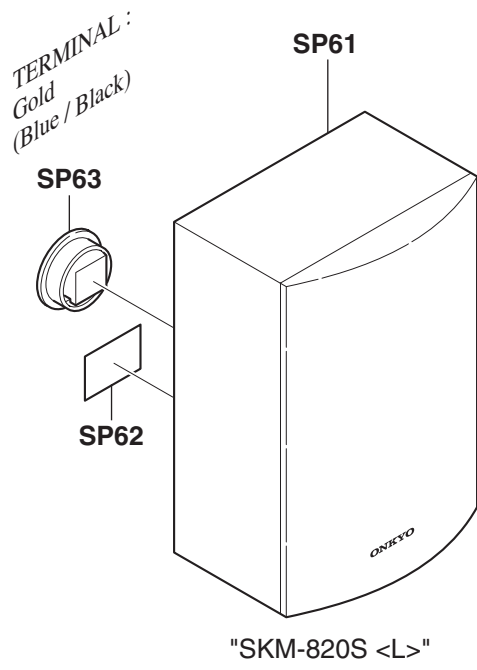

A

B

C

D

# SCHEMATIC DIAGRAM

## SKW-820 : POWERED SUBWOOFER

### U02 INPUT TERMINAL PC BOARD

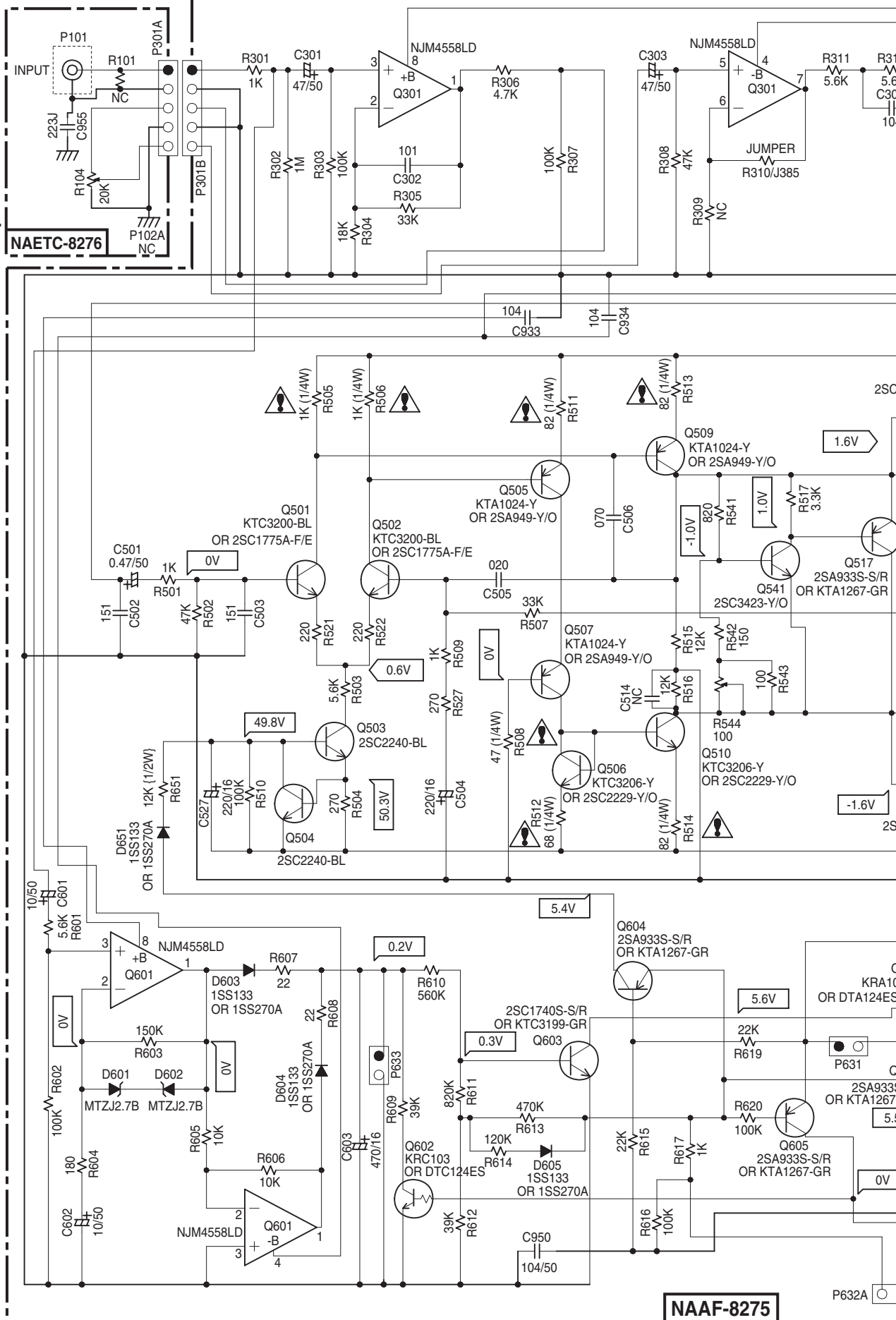

### NAAF-8275

### U01 AMPLIFIER PC BOARD



E

F

G

H

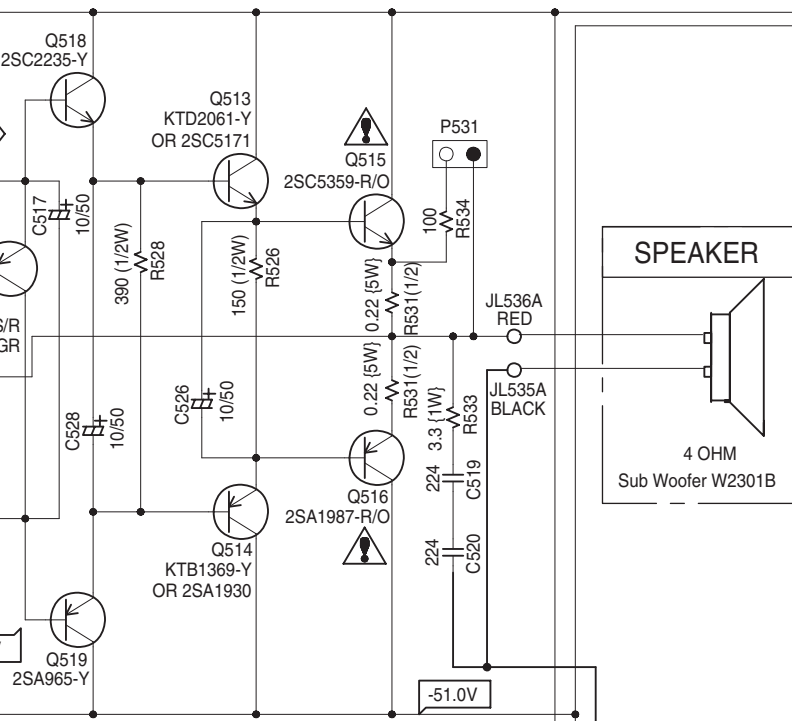
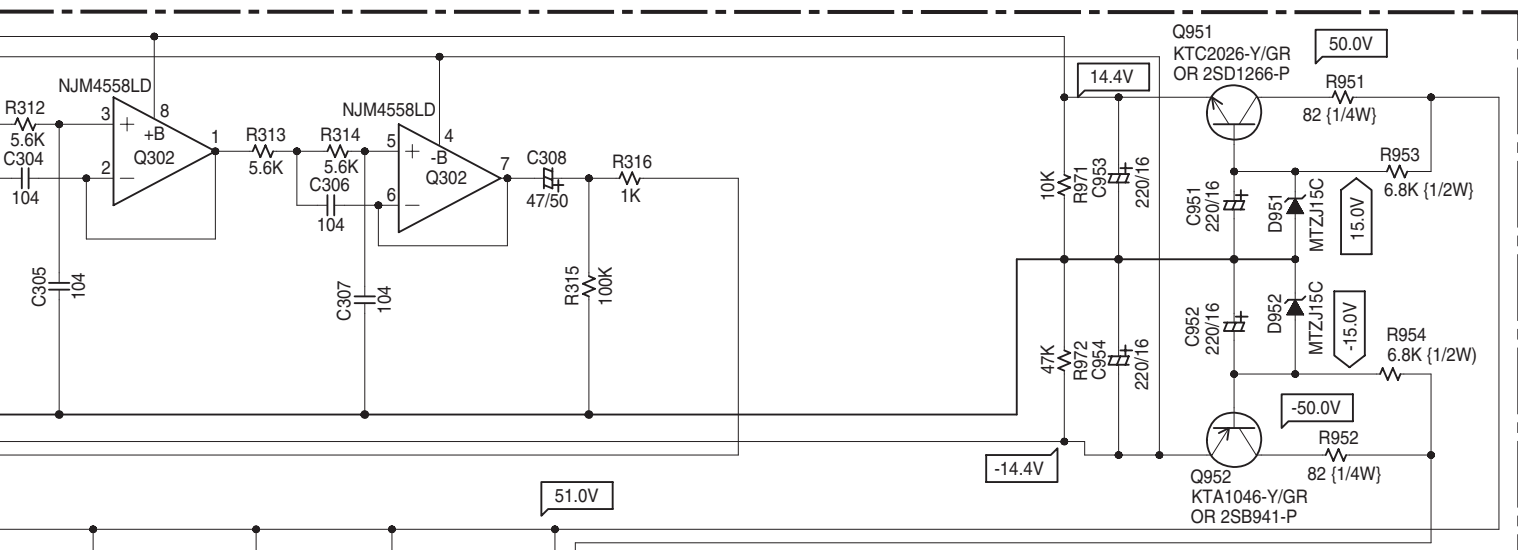

**NOTE**

- THE COMPONENTS IDENTIFIED BY MARK ARE CRITICAL FOR SAFETY. REPLACE ONLY WITH PART NUMBER SPECIFIED.
- VOLTAGE (MEASURED WITH VOLTMETER) IS DC VOLTAGE.(NO INPUT SIGNAL).
- ALL PNP TRANSISTORS ARE EQUIVALENT TO 2SA1015-GR UNLESS OTHERWISE NOTED.
- ALL NPN TRANSISTORS ARE EQUIVALENT TO 2SC1815-GR UNLESS OTHERWISE NOTED.
- ALL DIODES ARE EQUIVALENT TO 1SS133 UNLESS OTHERWISE NOTED.
- ELECTROLYTIC CAPACITORS ( ) ARE IN uF/WV.
- ALL CAPACITORS ARE IN pF/50WV UNLESS OTHERWISE NOTED.  
EX) 030- 3pF 330- 33pF 331- 330pF 333- 0.033uF
- ALL RESISTORS ARE IN OHMS 1/4WATTS UNLESS OTHERWISE NOTED.
- THE THICK LINES ON PC BOARD ARE THE PRINTING SIDE OF THE PARTS.  
EX) PRINTING SIDE
- CIRCUIT IS SUBJECT TO CHANGE FOR IMPROVEMENT.

**CAUTION**

FOR CONTINUED PROTECTION AGAINST FIRE HAZARD, REPLACE ONLY WITH FUSE OF SAME TYPE AND RATING INDICATED.

**ATTENTION**

AFIN D'ASSURER UNE PROTECTION PERMANENTE CONTRE LES RISQUES D'INCENDIE, REMPLACER UNIQUEMENT PAR UN FUSIBLE DE MEME TYPE ET CALIBRATION COMME INDIQUE.

THIS SYMBOL LOCATED NEAR THE FUSE INDICATES THAT THE FUSE USED IS SLOW OPERATING TYPE FOR CONTINUED PROTECTION AGAINST FIRE HAZARD,REPLACE WITH SAME TYPE FUSE. FOR FUSE RATING REFER TO THE MARKING ADJACENT TO THE SYMBOL

CE SYMBOLE INDIQUE QUE LE FUSIBLE UTILISE EST E LENT. POUR UNE PROTECTION PERMANENTE,N'UTILISER QUE DES FUSIBLES DE MEME TYPE. CE DARNIER EST INDIQUE LA QU LE PRESENT SYMBOLE EST APPOSE.

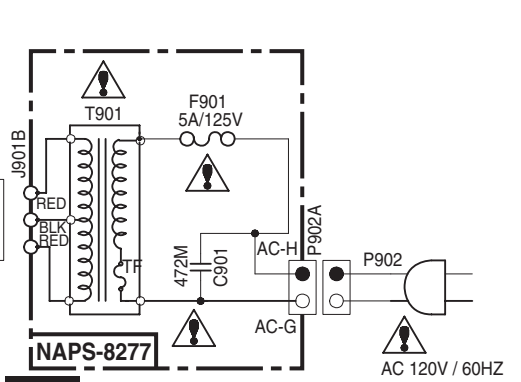
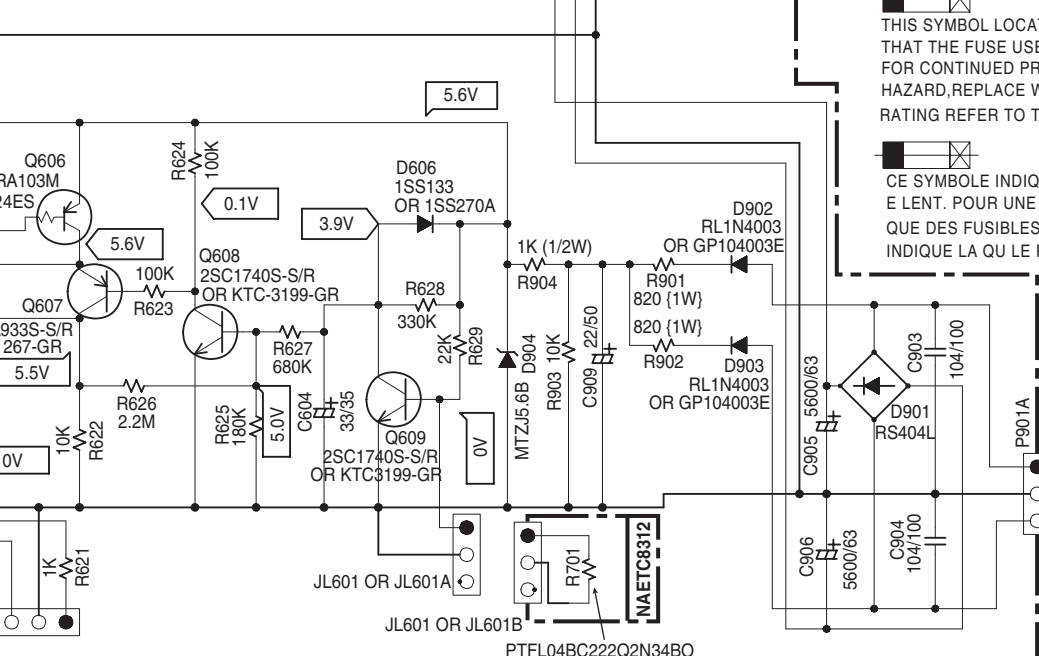

**U04 THERMAL SENSOR PC BOARD**

**U03 POWER TRANSFORMER PC BOARD**

AC 120V / 60HZ

SCHEMATIC DIAGRAM

SKW-820 :  
POWERED  
SUBWOOFER

U02  
INPUT TERMINAL  
PC BOARD

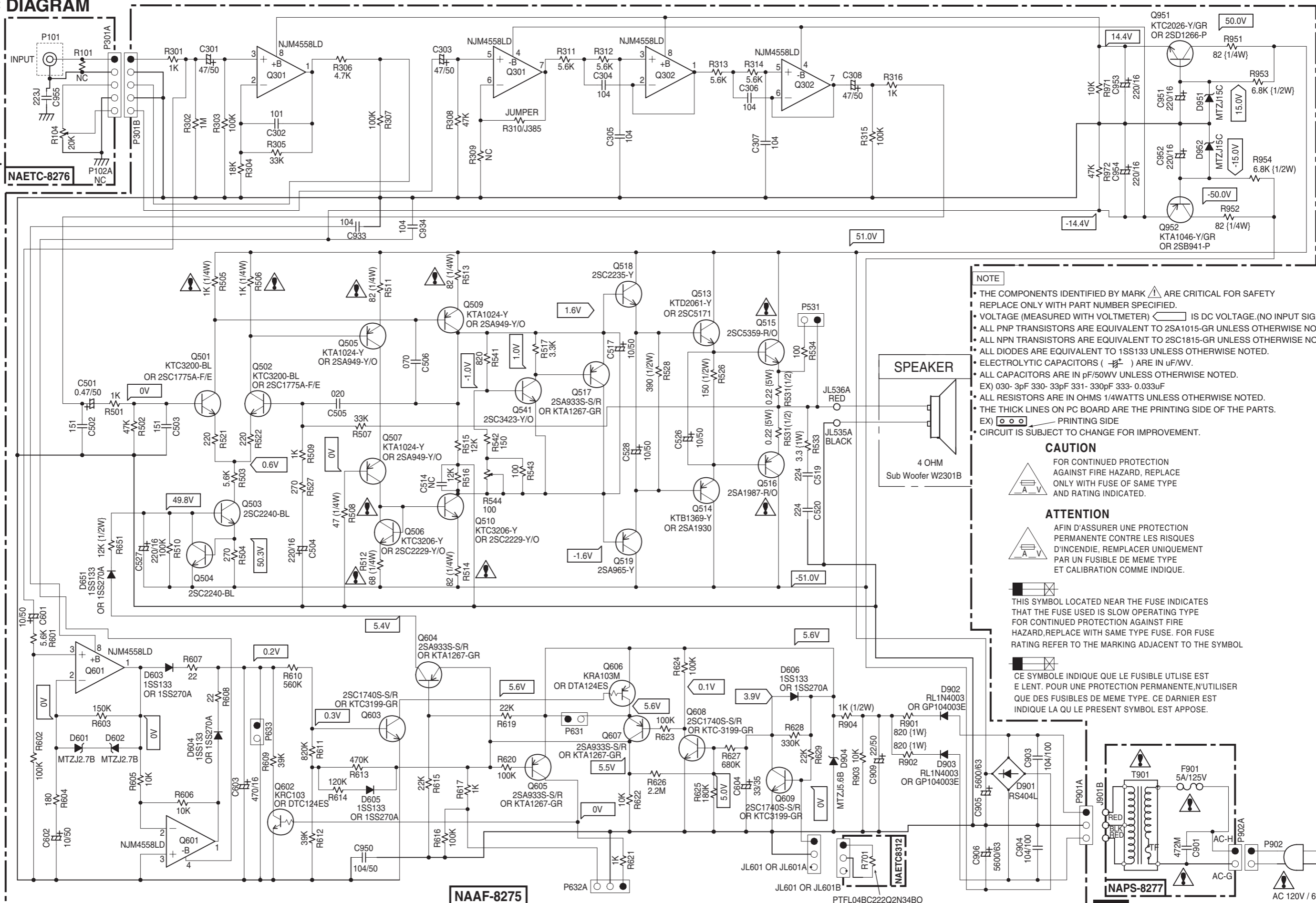

- NOTE**
- THE COMPONENTS IDENTIFIED BY MARK ARE CRITICAL FOR SAFETY. REPLACE ONLY WITH PART NUMBER SPECIFIED.
  - VOLTAGE (MEASURED WITH VOLTMETER) IS DC VOLTAGE. (NO INPUT SIGNAL).
  - ALL PNP TRANSISTORS ARE EQUIVALENT TO 2SA1015-GR UNLESS OTHERWISE NOTED.
  - ALL NPN TRANSISTORS ARE EQUIVALENT TO 2SC1815-GR UNLESS OTHERWISE NOTED.
  - ALL DIODES ARE EQUIVALENT TO 1SS133 UNLESS OTHERWISE NOTED.
  - ELECTROLYTIC CAPACITORS ( ) ARE IN uF/WV.
  - ALL CAPACITORS ARE IN pF/50V UNLESS OTHERWISE NOTED. EX) 030- 3pF 330- 33pF 331- 330pF 333- 0.03uF
  - ALL RESISTORS ARE IN OHMS 1/4WATTS UNLESS OTHERWISE NOTED.
  - THE THICK LINES ON PC BOARD ARE THE PRINTING SIDE OF THE PARTS. EX) PRINTING SIDE
  - CIRCUIT IS SUBJECT TO CHANGE FOR IMPROVEMENT.

**CAUTION**

FOR CONTINUED PROTECTION AGAINST FIRE HAZARD, REPLACE ONLY WITH FUSE OF SAME TYPE AND RATING INDICATED.

**ATTENTION**

AFIN D'ASSURER UNE PROTECTION PERMANENTE CONTRE LES RISQUES D'INCENDIE, REMPLACER UNIQUEMENT PAR UN FUSIBLE DE MEME TYPE ET CALIBRATION COMME INDIQUE.

THIS SYMBOL LOCATED NEAR THE FUSE INDICATES THAT THE FUSE USED IS SLOW OPERATING TYPE FOR CONTINUED PROTECTION AGAINST FIRE HAZARD, REPLACE WITH SAME TYPE FUSE. FOR FUSE RATING REFER TO THE MARKING ADJACENT TO THE SYMBOL

CE SYMBOLE INDIQUE QUE LE FUSIBLE UTILISE EST LENT. POUR UNE PROTECTION PERMANENTE, UTILISER QUE DES FUSIBLES DE MEME TYPE. CE DERNIER EST INDIQUE LA QU LE PRESENT SYMBOLE EST APPOSE.

1

2

3

4

5

NAETC-8276

NAAF-8275

PTFL04BC222Q2N34B0

NAPS-8277

U01 AMPLIFIER PC BOARD

U04 THERMAL SENSOR PC BOARD

U03 POWER TRANSFORMER PC BOARD

AC 120V / 60HZ



A

B

C

D

# PRINTED CIRCUIT BOARD VIEWS-2

## SKW-820 : POWERED SUBWOOFER

1

### U02 INPUT TERMINAL PC BOARD (NAETC-8276)

Soldering side

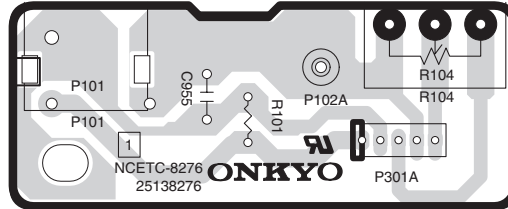

2

### U03 POWER TRANSFORMER PC BOARD (NAPS-8277)

Soldering side

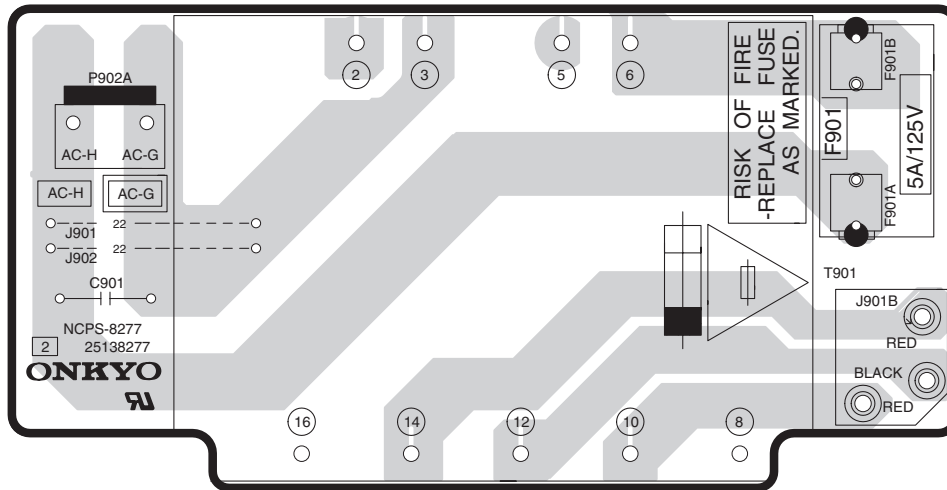

3

4

### U04 THERMAL SENSOR PC BOARD (NAETC-8312)

Soldering side

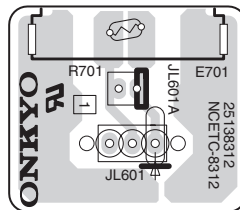

5

### U05 HOLDER PC BOARD (NAETC-8317)

No PC board view

# ADJUSTMENT PROCEDURE

## SKW-820 : POWERED SUBWOOFER /

### ADJUSTMENT OF IDLING CURRENT

1. Before adjustment of idling current, turn the trimming resistor R544 to counter clockwise.
2. Short test point P631 for Amplifier is under active mode.
3. Connect the DC voltmeter to test point P531.
4. After turn POWER to ON, adjust the trimming resistor R544 so that the reading of voltmeter becomes 0.25 mV.

**<Note> No speaker load and No input signal.**

5. Confirm the voltage of above point after five minutes.
6. When less than 4.40 mV : Readjust the trimming resistor above so that the voltage becomes 4.5 mV to 5.0 mV.  
When 4.41 mV to 5.50 mV : Not necessary to adjust.  
When more than 5.51 mV : Readjust the trimming resistor above so that the voltage becomes 5.0 mV to 5.5 mV.

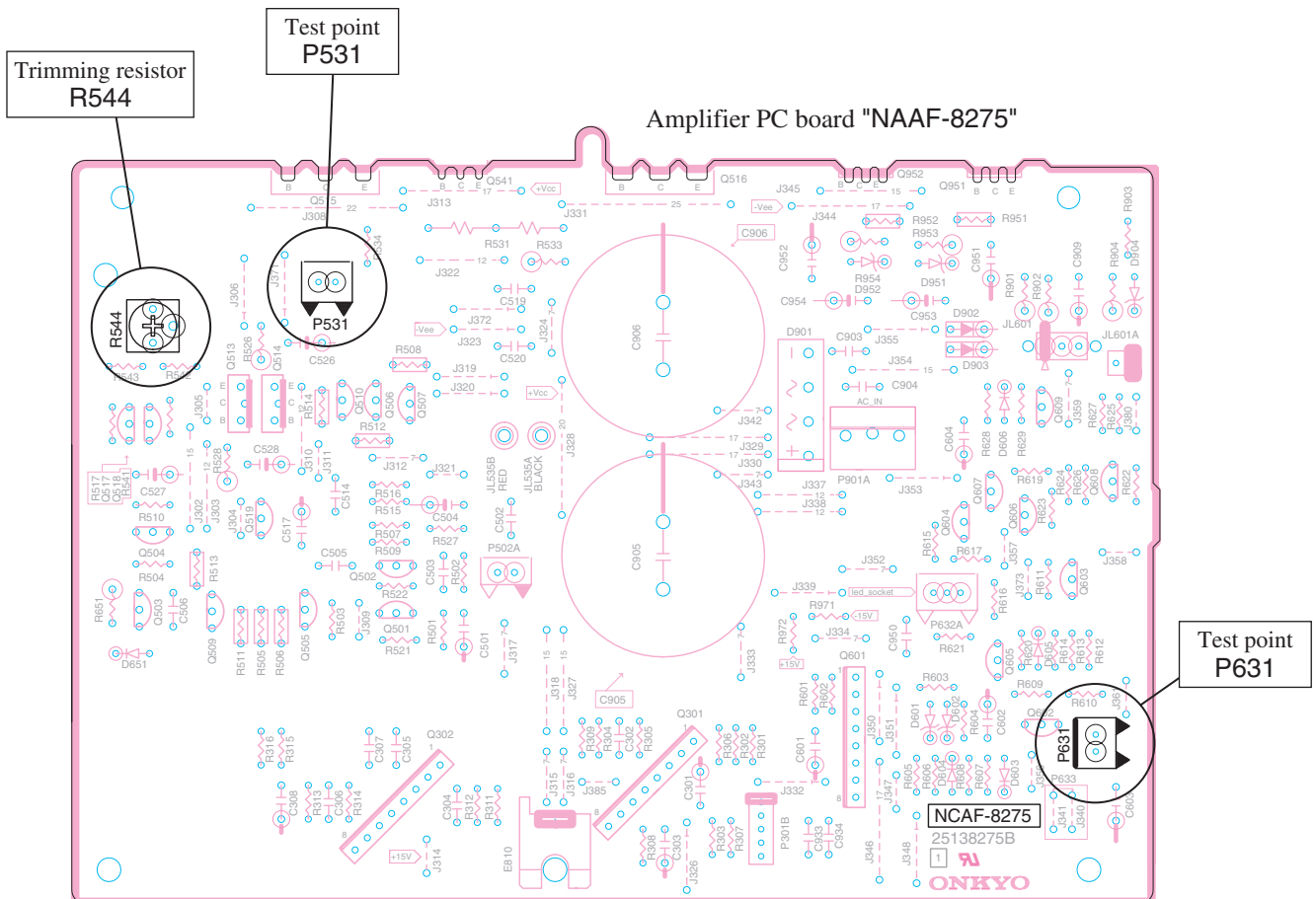

HTP-820

## EXPLODED VIEWS PARTS LIST

NOTE : THE COMPONENTS IDENTIFIED BY THE MARK  
! ARE CRITICAL FOR RISK OF FIRE AND  
ELECTRIC SHOCK. REPLACE ONLY WITH PART  
NUMBER SPECIFIED.

&lt;Notes&gt;

&lt;L&gt; : Lch

&lt;R&gt; : Rch

REF. NO.	PART NAME	DESCRIPTION	Q'TY	PART NO. (SN)	MARK
EXPLODED:	<b>SKW-820 (S) : POWERED SUBWOOFER</b>				
EXPLODED:	<b>AMPLIFIER SECTION (SKW-820)</b>				
EXPLODED:	Q515	TR	1	2203082	!
EXPLODED:	Q515 or	TR	(1)	2203083	!
EXPLODED:	Q516	TR	1	2203072	!
EXPLODED:	Q516 or	TR	(1)	2203073	!
EXPLODED:	Q541	TR	1	2202104	
EXPLODED:	Q541 or	TR	(1)	2202103	
EXPLODED:	Q951	TR	1	2203594	
EXPLODED:	Q951 or	TR	(1)	2203595	
EXPLODED:	Q951 or	TR	(1)	2202754	
EXPLODED:	Q952	TR	1	2203614	
EXPLODED:	Q952 or	TR	(1)	2203615	
EXPLODED:	Q952 or	TR	(1)	2202764	
EXPLODED:	<Note>				
EXPLODED:	When replacement the following the transistor, made from the same HFE rank as the original type.				
EXPLODED:	Q515, Q516, Q541, Q951, Q952				
EXPLODED:	A01	HEAT SINK	1	27160547	
EXPLODED:	A02	CUSHION	2	28141572A	
EXPLODED:	A03	CUSHION	2	28141573A	
EXPLODED:	A04	CUSHION	1	28141574	
EXPLODED:	A05	SCREW	8	838430088	
EXPLODED:	A05	SCREW	3	838430088	
EXPLODED:	A06	BRACKET	2	27130745	
EXPLODED:	A07	ISO SHEET	2	223025	
EXPLODED:	A08	SCREW	2	801433	
EXPLODED:	A10	SCREW	1	838130088	
EXPLODED:	A10	SCREW	4	838130088	
EXPLODED:	A10	SCREW	2	838130088	
EXPLODED:	A11	RETAINER	1	27141912	
EXPLODED:	A13	COVER	1	28184894	
EXPLODED:	A15	RETAINER	1	27141913	
EXPLODED:	A16	SCREW	2	838430128	
EXPLODED:	A101	REAR PANEL	1	27123338A	
EXPLODED:	A102	BUSHING	1	27300750	!
EXPLODED:	A103	KNOB	1	28326201	
EXPLODED:	F901	FUSE	1	252164	!
EXPLODED:	P902	AC CORD	1	253333VOL	!
EXPLODED:	P902 or	AC CORD	(1)	253368LTK	!
EXPLODED:	T901	P TRANS	1	2301745	!
EXPLODED:	U01	AMPLIFIER PC BOARD	1	1B032575-1B	
EXPLODED:	U02	INPUT TERMINAL PC BOARD	1	1B032576-1B	

EXPLODED:	U03	POWER TRANSFORMER PC BOARD	NAPS-8277-1B	1	1B032577-1B	
EXPLODED:	U04	THERMAL SENSOR PC BOARD	NAETC-8312-1B	1	1B032512-1B	
EXPLODED:	U05	HOLDER PC BOARD	NAETC-8317-1B	1	1B032517-1B	
EXPLODED:	<b>SKW-820 (S) : POWERED SUBWOOFER</b>					
EXPLODED:	<b>SPEAKER SECTION (SKW-820)</b>					
EXPLODED:	SP01	CABINET ASS'Y	SKW-820 (S)	1	000-SKW820GYSER	
EXPLODED:	SP02	CLOTH FRAME ASS'Y	SKW-820	2	113-03W820-00	
EXPLODED:	SP04	PLASTIC FOOT	---	4	249-W82001B-10	
EXPLODED:	SP05	CUSHION	1.5T x 19 x 19 (For FOOT)	4	442-915103-00	
EXPLODED:	SP06	WOOD SCREW	3 x 20 BIND (For FOOT)	4	411-B83020AB1	
EXPLODED:	SP07	NAME PLATE	(SKW-820 / ONKYO)	1	D231-W82001B-20	
EXPLODED:	SP08	WOOFER	8" (20cm) / 6 ohm 60 W (ONKYO)	2	W20176D	
EXPLODED:	SP09	WOOD SCREW	4STT + 20A (FOR AMP x 10 / SP x 16)	26	837440204	
EXPLODED:	SP10	CUSHION	CUSHION PCB (For P-TRANSFORMER)	2	443-SKW-820-00	
EXPLODED:	SP11	SCREW	4 x 25 (For POWER TRANSFORMER)	8	412-D840250B1	
EXPLODED:	SP12	SPEAKER CORD	---	1	312-SKW820-00	
EXPLODED:	SP13	BUTYL	MS665 18 x 18 x 6T	2	560-6MS665-00	
EXPLODED:	SP14	LED HARNESS ASS'Y	---	1	335-SKW520-00	
EXPLODED:	SP15	CUSHION	PEF 5 x 220 x 1T (For CLOTH FRAME)	2	442-101205-00	
EXPLODED:	SP16	UL LABEL	(For AMP, REAR PANEL)	1	660-HTS870-00	
EXPLODED:	<b>SKF-820F (S) &lt;L&gt; / &lt;R&gt; : FRONT SPEAKERS</b>					
EXPLODED:	SP20a	COMPLETE UNIT	"SKF-820F (S) <L>"	1	000-SKF820FLGY	<L>
EXPLODED:	SP20b	COMPLETE UNIT	"SKF-820F (S) <R>"	1	000-SKF820FRGY	<R>
EXPLODED:	SP21a	CABINET ASS'Y	SKF-820F (S) <L> (Without TERMINAL)	1	000-SKF820LGYSER	<L>
EXPLODED:	SP21b	CABINET ASS'Y	SKF-820F (S) <R> (Without TERMINAL)	1	000-SKF820RGYSER	<R>
EXPLODED:	SP22	CATCHING HOLDER	---	4	D230-DN3X01B-01	
EXPLODED:	SP23	WOOFER	W1367A (ONKYO)	2	W1367A	
EXPLODED:	SP24	TWEETER	TW3208A (ONKYO)	1	TW3208A	
EXPLODED:	SP26	SCREW	4 x 16 HEX 8.3ED (For WOOFER)	8	411-H84016AB2	
EXPLODED:	SP27	SCREW	3.5 x 16 HEX 7.0ED (For TWEETER)	4	411-H83516AB1	
EXPLODED:	SP28	NETWORK ASS'Y	---	1	311-870THX-00	
EXPLODED:	SP29	SCREW	3.5 x 20 BIND (For N / W)	4	411-B83520AB1	
EXPLODED:	SP30a	TERMINAL	WHITE / BLACK	1	332-H8180G-20	<L>
EXPLODED:	SP30b	TERMINAL	RED / BLACK	1	332-H8180G-00	<R>
EXPLODED:	SP31a	SPEC LABEL (L)	---	1	600-KF820L-00	<L>
EXPLODED:	SP31b	SPEC LABEL (R)	---	1	600-KF820R-00	<R>
EXPLODED:	SP33	GRILLE ASS'Y	(WITH GRILLE CLOTH and BADGE)	1	D201-F82001S-90	
EXPLODED:	SP34	BADGE	ONKYO	1	D213-M52001B-20	
EXPLODED:	<b>SKC-820C (S) : CENTER SPEAKER</b>					
EXPLODED:	SP40	COMPLETE UNIT	"SKC-820C (S)"	1	000-SKC820CGY	
EXPLODED:	SP41	CABINET ASS'Y	SKC-820C (S) (Without TERMINAL)	1	000-SKC820GYSER	
EXPLODED:	SP42	CATCHING HOLDER	---	4	D230-DN3X01B-01	
EXPLODED:	SP43	WOOFER	W1069A (ONKYO)	2	W1069A	
EXPLODED:	SP44	TWEETER	TW3208A (ONKYO)	1	TW3208A	
EXPLODED:	SP46	SCREW	4 x 16 HEX 8.3ED (For WOOFER)	8	411-H84016AB2	
EXPLODED:	SP47	SCREW	3.5 x 16 HEX 7.0ED (For TWEETER)	4	411-H83516AB1	
EXPLODED:	SP48	NETWORK ASS'Y	---	1	311-870THX-00	
EXPLODED:	SP49	SCREW	3.5 x 20 BIND (For N / W)	4	411-B83520AB1	
EXPLODED:	SP50	TERMINAL	GREEN / BLACK	1	332-H8180G-30	
EXPLODED:	SP51	SPEC LABEL	---	1	600-SKC820-00	
EXPLODED:	SP53	GRILLE ASS'Y	(WITH GRILLE CLOTH and BADGE)	1	D201-C82001S-90	

EXPLODED:	SP54	BADGE	ONKYO	1	D213-M52001B-20	
EXPLODED:	<b>SKM-820S (S) &lt;L&gt; / &lt;R&gt; : SURROUND SPEAKERS</b>					
EXPLODED:	SP61	COMPLETE UNIT	"SKM-820S (S) <L>"	1	000-SKM820SLGY	<L>
EXPLODED:	SP62	SPEC LABEL (L)	---	1	600-KM820L-00	<L>
EXPLODED:	SP63	TERMINAL	BLUE / BLACK	1	332-H8108G-50	<L>
EXPLODED:	SP64	COMPLETE UNIT	"SKM-820S (S) <R>"	1	000-SKM820SRGY	<R>
EXPLODED:	SP65	SPEC LABEL (R)	---	1	600-KM820R-00	<R>
EXPLODED:	SP66	TERMINAL	GRAY / BLACK	1	332-H8108G-40	<R>
EXPLODED:	<b>SKB-820 (S) : SURROUND BACK SPEAKER</b>					
EXPLODED:	SP67	COMPLETE UNIT	"SKB-820 (S)"	1	000-SKB820GY	
EXPLODED:	SP68	SPEC LABEL	---	1	600-SKB820-00	
EXPLODED:	SP69	TERMINAL	BROWN / BLACK	1	332-H8108G-10	

**HTP-820****PRINTED CIRCUIT BOARD PARTS LIST**

**NOTE : THE COMPONENTS IDENTIFIED BY THE MARK  
! ARE CRITICAL FOR RISK OF FIRE AND  
ELECTRIC SHOCK. REPLACE ONLY WITH PART  
NUMBER SPECIFIED.**

**SKW-820**

<b>U01</b>	AMPLIFIER PC BOARD (NAAF-8275-1B)
<b>U02</b>	INPUT TERMINAL PC BOARD (NAETC-8276-1B)
<b>U03</b>	POWER TRANSFORMER PC BOARD (NAPS-8277-1B)
<b>U04</b>	THERMAL SENSOR PC BOARD (NAETC-8312-1B)
<b>U05</b>	HOLDER PC BOARD (NAETC-8317-1B)

	CIRCUIT NO.	PART NAME	DESCRIPTION	Q'TY	PART NO. (SN)	MARK
PWB	Q301	IC	NJM4558L-D	1	22240293	
PWB	Q302	IC	NJM4558L-D	1	22240293	
PWB	Q601	IC	NJM4558L-D	1	22240293	
PWB	Q501	TR	KTC3200-BL	1	2215896	
PWB	Q501 or	TR	2SC1775A-E	(1)	2210755	
PWB	Q501 or	TR	2SC1775A-F	(1)	2210756	
PWB	Q502	TR	KTC3200-BL	1	2215896	
PWB	Q502 or	TR	2SC1775A-E	(1)	2210755	
PWB	Q502 or	TR	2SC1775A-F	(1)	2210756	
PWB	Q503	TR	2SC2240-BL	1	2211406	
PWB	Q504	TR	2SC2240-BL	1	2211406	
PWB	Q505	TR	KTA1024-Y	1	2215844	
PWB	Q505 or	TR	KTA1024-O	(1)	2215843	
PWB	Q505 or	TR	2SA949-Y	(1)	2211354	
PWB	Q505 or	TR	2SA949-O	(1)	2211353	
PWB	Q506	TR	KTC3206-Y	1	2215854	
PWB	Q506 or	TR	KTC3206-O	(1)	2215853	
PWB	Q506 or	TR	2SC2229-Y	(1)	2211634	
PWB	Q506 or	TR	2SC2229-O	(1)	2211633	
PWB	Q507	TR	KTA1024-Y	1	2215844	
PWB	Q507 or	TR	KTA1024-O	(1)	2215843	
PWB	Q507 or	TR	2SA949-Y	(1)	2211354	
PWB	Q507 or	TR	2SA949-O	(1)	2211353	



PWB	Q509	TR	KTA1024-Y	1	2215844
PWB	Q509 or	TR	KTA1024-O	(1)	2215843
PWB	Q509 or	TR	2SA949-Y	(1)	2211354
PWB	Q509 or	TR	2SA949-O	(1)	2211353
PWB	Q510	TR	KTC3206-Y	1	2215854
PWB	Q510 or	TR	KTC3206-O	(1)	2215853
PWB	Q510 or	TR	2SC2229-Y	(1)	2211634
PWB	Q510 or	TR	2SC2229-O	(1)	2211633
PWB	Q513	TR	KTD2061-Y	1	2203434
PWB	Q513 or	TR	2SD1763-E	(1)	2201945
PWB	Q513 or	TR	2SD1763A-D	(1)	2202034
PWB	Q513 or	TR	2SC5171	(1)	2203010
PWB	Q514	TR	KTB1369-Y	1	2203424
PWB	Q514 or	TR	2SB1186-E	(1)	2201935
PWB	Q514 or	TR	2SB1186A-D	(1)	2202024
PWB	Q514 or	TR	2SA1930	(1)	2203000
PWB	Q517	TR	2SA933S-S	1	2213355
PWB	Q517 or	TR	2SA933S-R	(1)	2213354
PWB	Q517 or	TR	KTA1267-GR	(1)	2215995
PWB	Q518	TR	2SC2235-Y	1	2211654
PWB	Q519	TR	2SA965-Y	1	2211644
PWB	Q602	TR	KRC103M	1	2215810
PWB	Q602 or	TR	DTC124ES	(1)	2213160
PWB	Q603	TR	2SC1740S-S	1	2213285
PWB	Q603 or	TR	2SC1740S-R	(1)	2213284
PWB	Q603 or	TR	KTC3199-GR	(1)	2215864
PWB	Q604	TR	2SA933S-S	1	2213355
PWB	Q604 or	TR	2SA933S-R	(1)	2213354
PWB	Q604 or	TR	KTA1267-GR	(1)	2215995
PWB	Q605	TR	2SA933S-S	1	2213355
PWB	Q605 or	TR	2SA933S-R	(1)	2213354
PWB	Q605 or	TR	KTA1267-GR	(1)	2215995
PWB	Q606	TR	KRA103M	1	2215780
PWB	Q606 or	TR	DTA124ES	(1)	2212600
PWB	Q606 or	TR	RN2203	(1)	2213580
PWB	Q607	TR	2SA933S-S	1	2213355
PWB	Q607 or	TR	2SA933S-R	(1)	2213354
PWB	Q607 or	TR	KTA1267-GR	(1)	2215995
PWB	Q608	TR	2SC1740S-S	1	2213285
PWB	Q608 or	TR	2SC1740S-R	(1)	2213284
PWB	Q608 or	TR	KTC3199-GR	(1)	2215864
PWB	Q609	TR	2SC1740S-S	1	2213285
PWB	Q609 or	TR	2SC1740S-R	(1)	2213284
PWB	Q609 or	TR	KTC3199-GR	(1)	2215864
PWB	<Note>				
PWB	When replacement the following the transistor, made from the same HFE rank as the original type.				
PWB	D601	ZENER D	MTZJ2.7B	1	224470272
PWB	D602	ZENER D	MTZJ2.7B	1	224470272
PWB	D603	DIODE	1SS133	1	223163
PWB	D603 or	DIODE	1SS270A	(1)	223205
PWB	D604	DIODE	1SS133	1	223163

PWB	D604 or	DIODE	ISS270A	(1)	223205	
PWB	D605	DIODE	ISS133	1	223163	
PWB	D605 or	DIODE	ISS270A	(1)	223205	
PWB	D606	DIODE	ISS133	1	223163	
PWB	D606 or	DIODE	ISS270A	(1)	223205	
PWB	D651	DIODE	ISS133	1	223163	
PWB	D651 or	DIODE	ISS270A	(1)	223205	
PWB	D901	DIODE	RS404L	1	22380277	
PWB	D902	DIODE	RL1N4003	1	22380260	
PWB	D902 or	DIODE	GP104003E	(1)	22380035	
PWB	D903	DIODE	RL1N4003	1	22380260	
PWB	D903 or	DIODE	GP104003E	(1)	22380035	
PWB	D904	ZENER D	MTZJ5.6B	1	224470562	
PWB	D951	ZENER D	MTZJ15C	1	224471503	
PWB	D952	ZENER D	MTZJ15C	1	224471503	
PWB	C301	VX C	CE04W50V-47M (VX)	1	393384707	
PWB	C302	TF C	ECQ-B50V-101K	1	374721015	
PWB	C303	VX C	CE04W50V-47M (VX)	1	393384707	
PWB	C304	TF C	ECQ-V50V-104J	1	374721044	
PWB	C305	TF C	ECQ-V50V-104J	1	374721044	
PWB	C306	TF C	ECQ-V50V-104J	1	374721044	
PWB	C307	TF C	ECQ-V50V-104J	1	374721044	
PWB	C308	VX C	CE04W50V-47M (VX)	1	393384707	
PWB	C501	VX C	CE04W50V-0.47M (VX)	1	393384797	
PWB	C502	TF C	ECQ-B50V-151K	1	374721515	
PWB	C503	TF C	ECQ-B50V-151K	1	374721515	
PWB	C504	VX C	CE04W16V-220M (VX)	1	393342217	
PWB	C505	CERA C	CC45CH50V-020C	1	345340201	
PWB	C506	CERA C	CC45CH50V-070D	1	345340702	
PWB	C517	VX C	CE04W50V-10M (VX)	1	393381007	
PWB	C519	TF C	ECQ-V50V-224J	1	374722244	
PWB	C520	TF C	ECQ-V50V-224J	1	374722244	
PWB	C526	VX C	CE04W50V-10M (VX)	1	393381007	
PWB	C527	VX C	CE04W16V-220M (VX)	1	393342217	
PWB	C528	VX C	CE04W50V-10M (VX)	1	393381007	
PWB	C601	VR C	CE04W50V-10M (VR)	1	394681007	
PWB	C602	VR C	CE04W50V-10M (VR)	1	394681007	
PWB	C603	VR C	CE04W10V-470M (VR)	1	394634717	
PWB	C603 or	VX C	CE04W16V-470M (VX)	(1)	393344717	
PWB	C604	VR C	CE04W35V-33M (VR)	1	394663307	
PWB	C604 or	ELECT C	CE04W35V-33M	(1)	354763309	
PWB	C901	IS C	DE1310E472M-KH	1	3300054	!
PWB	C901A	C COVER	SB1925A	1	27301216	!
PWB	C903	TF C	ECQ-V100-104J	1	374731044	
PWB	C904	TF C	ECQ-V100-104J	1	374731044	
PWB	C905	ELECT C	CE62W63V-5600M	1	3504414	
PWB	C906	ELECT C	CE62W63V-5600M	1	3504414	
PWB	C909	VR C	CE04W50V-22M (VR)	1	394682207	
PWB	C933	TF C	ECQ-V50V-104J	1	374721044	
PWB	C934	TF C	ECQ-V50V-104J	1	374721044	
PWB	C950	TF C	ECQ-V50V-104J	1	374721044	

PWB	C951	VR C	CE04W16V-220M (VR)	1	394642217	
PWB	C952	VR C	CE04W16V-220M (VR)	1	394642217	
PWB	C953	VR C	CE04W16V-220M (VR)	1	394642217	
PWB	C954	VR C	CE04W16V-220M (VR)	1	394642217	
PWB	C955	TF C	ECQ-B50V-223J	1	374722234	
PWB	R104	VARI R	N17RGL20KB15M	1	5151508	
PWB	R301	CARBON R	R16J-1K	1	417341024	
PWB	R302	CARBON R	R16J-1M	1	417341054	
PWB	R303	CARBON R	R16J-100K	1	417341044	
PWB	R304	CARBON R	R16J-18K	1	417341834	
PWB	R305	CARBON R	R16J-33K	1	417343334	
PWB	R306	CARBON R	R16J-4.7K	1	417344724	
PWB	R307	CARBON R	R16J-100K	1	417341044	
PWB	R308	CARBON R	R16J-47K	1	417344734	
PWB	R311	CARBON R	R16J-5.6K	1	417345624	
PWB	R312	CARBON R	R16J-5.6K	1	417345624	
PWB	R313	CARBON R	R16J-5.6K	1	417345624	
PWB	R314	CARBON R	R16J-5.6K	1	417345624	
PWB	R315	CARBON R	R16J-100K	1	417341044	
PWB	R316	CARBON R	R16J-1K	1	417341024	
PWB	R501	CARBON R	R16J-1K	1	417341024	
PWB	R502	CARBON R	R16J-47K	1	417344734	
PWB	R503	CARBON R	R16J-5.6K	1	417345624	
PWB	R504	CARBON R	R16J-270	1	417342714	
PWB	R505	NF CARBON R	R25J-1.0K	1	415471024	!
PWB	R506	NF CARBON R	R25J-1.0K	1	415471024	!
PWB	R507	CARBON R	R16J-33K	1	417343334	
PWB	R508	NF CARBON R	R25J-47	1	415474704	!
PWB	R509	CARBON R	R16J-1K	1	417341024	
PWB	R510	CARBON R	R16J-100K	1	417341044	
PWB	R511	NF CARBON R	R25J-82	1	415478204	!
PWB	R512	NF CARBON R	R25J-68	1	415476804	!
PWB	R513	NF CARBON R	R25J-82	1	415478204	!
PWB	R514	NF CARBON R	R25J-82	1	415478204	!
PWB	R515	CARBON R	R16J-12K	1	417341234	
PWB	R516	CARBON R	R16J-12K	1	417341234	
PWB	R517	CARBON R	R16J-3.3K	1	417343324	
PWB	R521	CARBON R	R16J-220	1	417342214	
PWB	R522	CARBON R	R16J-220	1	417342214	
PWB	R526	METAL O R	RS1/2WBJ-150	1	443521514	
PWB	R527	CARBON R	R16J-270	1	417342714	
PWB	R528	METAL O R	RS1/2WBJ-390	1	443523914	
PWB	R531	METAL PR	RF-5EGKR22	1	4000201	
PWB	R531 or	METAL P R	RGC55C 0.22 K	(1)	4000157	
PWB	R533	METAL R	RNU1WCJ-3.3	1	453630334	
PWB	R534	CARBON R	R16J-100	1	417341014	
PWB	R541	CARBON R	R16J-820	1	417348214	
PWB	R542	CARBON R	R16J-150	1	417341514	
PWB	R543	CARBON R	R16J-100	1	417341014	
PWB	R544	TRIM R	N06HR100BC	1	5210359	
PWB	R601	CARBON R	R16J-5.6K	1	417345624	

PWB	R602	CARBON R	R16J-100K	1	417341044	
PWB	R603	CARBON R	R16J-150K	1	417341544	
PWB	R604	CARBON R	R16J-180	1	417341814	
PWB	R605	CARBON R	R16J-10K	1	417341034	
PWB	R606	CARBON R	R16J-10K	1	417341034	
PWB	R607	CARBON R	R16J-22	1	417342204	
PWB	R608	CARBON R	R16J-22	1	417342204	
PWB	R609	CARBON R	R16J-39K	1	417343934	
PWB	R610	CARBON R	R16J-560K	1	417345644	
PWB	R611	CARBON R	R16J-820K	1	417348244	
PWB	R612	CARBON R	R16J-39K	1	417343934	
PWB	R613	CARBON R	R16J-470K	1	417344744	
PWB	R614	CARBON R	R16J-120K	1	417341244	
PWB	R615	CARBON R	R16J-22K	1	417342234	
PWB	R616	CARBON R	R16J-100K	1	417341044	
PWB	R617	CARBON R	R16J-1K	1	417341024	
PWB	R619	CARBON R	R16J-22K	1	417342234	
PWB	R620	CARBON R	R16J-100K	1	417341044	
PWB	R621	CARBON R	R16J-1K	1	417341024	
PWB	R622	CARBON R	R16J-10K	1	417341034	
PWB	R623	CARBON R	R16J-100K	1	417341044	
PWB	R624	CARBON R	R16J-100K	1	417341044	
PWB	R625	CARBON R	R16J-180K	1	417341844	
PWB	R626	CARBON R	R16J-2.2M	1	417342254	
PWB	R627	CARBON R	R16J-680K	1	417346844	
PWB	R628	CARBON R	R16J-330K	1	417343344	
PWB	R629	CARBON R	R16J-22K	1	417342234	
PWB	R651	METAL O R	RS1/2WBJ-12K	1	443521234	
PWB	R701	RESISTOR	PTFL04BC222 (100)	1	4000230	
PWB	R901	METAL O R	RS1WBJ-820	1	443628214	
PWB	R902	METAL O R	RS1WBJ-820	1	443628214	
PWB	R903	CARBON R	R16J-10K	1	417341034	
PWB	R904	METAL O R	RS1/2WBJ-1K	1	443521024	
PWB	R951	NF CARBON R	R25J-82	1	415478204	
PWB	R952	NF CARBON R	R25J-82	1	415478204	
PWB	R953	METAL O R	RS1/2WBJ-6.8K	1	443526824	
PWB	R954	METAL O R	RS1/2WBJ-6.8K	1	443526824	
PWB	R971	CARBON R	R16J-10K	1	417341034	
PWB	R972	CARBON R	R16J-47K	1	417344734	
PWB	F901A	FUSE HOL	NSCT-1P2506	1	25052609	!
PWB	F901A or	FUSE HOL	NSCT-1P2031	(1)	25052133	!
PWB	F901B	FUSE HOL	NSCT-1P2506	1	25052609	!
PWB	F901B or	FUSE HOL	NSCT-1P2031	(1)	25052133	!
PWB	JL535A	SOCKET AS	NSAS-2P1335	1	2009990876UL	
PWB	JL601	JUMPER LEAD	JL3 120 H	1	---	
PWB	JL601A	WIRE HOL	NSCT-3P894	1	25051107	
PWB	JL601B	WIRE HOL	NSCT-3P894	1	25051107	
PWB	P101	PIN JACK	NPJ-1PDB581	1	25045801	
PWB	P301B	PLUG	NPLG-5P133	1	25055149	
PWB	P302A	SOCKET AS	NSAS-10P0798	1	2009990587UL	
PWB	P531	PLUG	NPLG-2P29	1	25055038	

PWB	P631	PLUG	NPLG-2P29	1	25055038	
PWB	P632A	PLUG	NPLG-3P131	1	25055147	
PWB	P901A	PLUG	NPLG-3P150	1	25055166	
PWB	P901B	SOCKET AS	NSAS-6P1333	1	2009990874UL	
PWB	P902A	PLUG	NPLG-2P632	1	25055676	!
PWB	E701	SHLD CASE	(THERMISTOR)	1	27225154A	
PWB	E810	RETAINER	KANAGU (EARTH)	1	27141059	

---

**ONKYO CORPORATION**

Sales & Product Planning Div. : 2-1, Nisshin-cho, Neyagawa-shi, OSAKA 572-8540, JAPAN  
Tel: 072-831-8023 Fax: 072-831-8124

**ONKYO U.S.A. CORPORATION**

18 Park Way, Upper Saddle River, N.J. 07458, U.S.A.  
Tel: 201-785-2600 Fax: 201-785-2650 <http://www.onkyousa.com>

**ONKYO EUROPE ELECTRONICS GmbH**

Liegnitzerstrasse 6, 82194 Groebenzell, GERMANY  
Tel: +49-8142-4401-0 Fax: +49-8142-4401-555 <http://www.onkyo.net>

**ONKYO EUROPE UK Office**

Suite 1, Gregories Court, Gregories Road, Beaconsfield, Buckinghamshire, HP9 1HQ  
UNITED KINGDOM Tel: +44-(0)1494-681515 Fax: +44(0)-1494-680452

**ONKYO CHINA LIMITED**

Units 2102-2107, Metroplaza Tower I, 223 Hing Fong Road, Kwai Chung,  
N.T., HONG KONG Tel: 852-2429-3118 Fax: 852-2428-9039