

# ONKYO SERVICE MANUAL

## AV RECEIVER MODEL HT-R280(B)

Black model

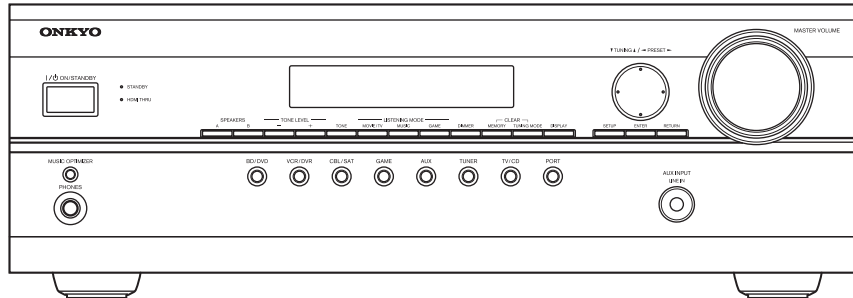

HT-R280(B) in HTiB "AVX-280(B)"  
<MDC> : 120V, 60Hz, Canadian model

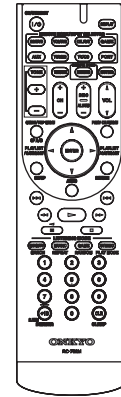

RC-762M

### SAFETY-RELATED COMPONENT WARNING!!

COMPONENTS IDENTIFIED BY MARK  ON THE SCHEMATIC DIAGRAM AND IN THE PARTS LIST ARE CRITICAL FOR RISK OF FIRE AND ELECTRIC SHOCK. REPLACE THESE COMPONENTS WITH ONKYO PARTS WHOSE PART NUMBERS APPEAR AS SHOWN IN THIS MANUAL.

MAKE LEAKAGE-CURRENT OR RESISTANCE MEASUREMENTS TO DETERMINE THAT EXPOSED PARTS ARE ACCEPTABLY INSULATED FROM THE SUPPLY CIRCUIT BEFORE RETURNING THE APPLIANCE TO THE CUSTOMER.

## TROUBLE SHOOT-1 No Power

This is just for general reference and does not including every single case.

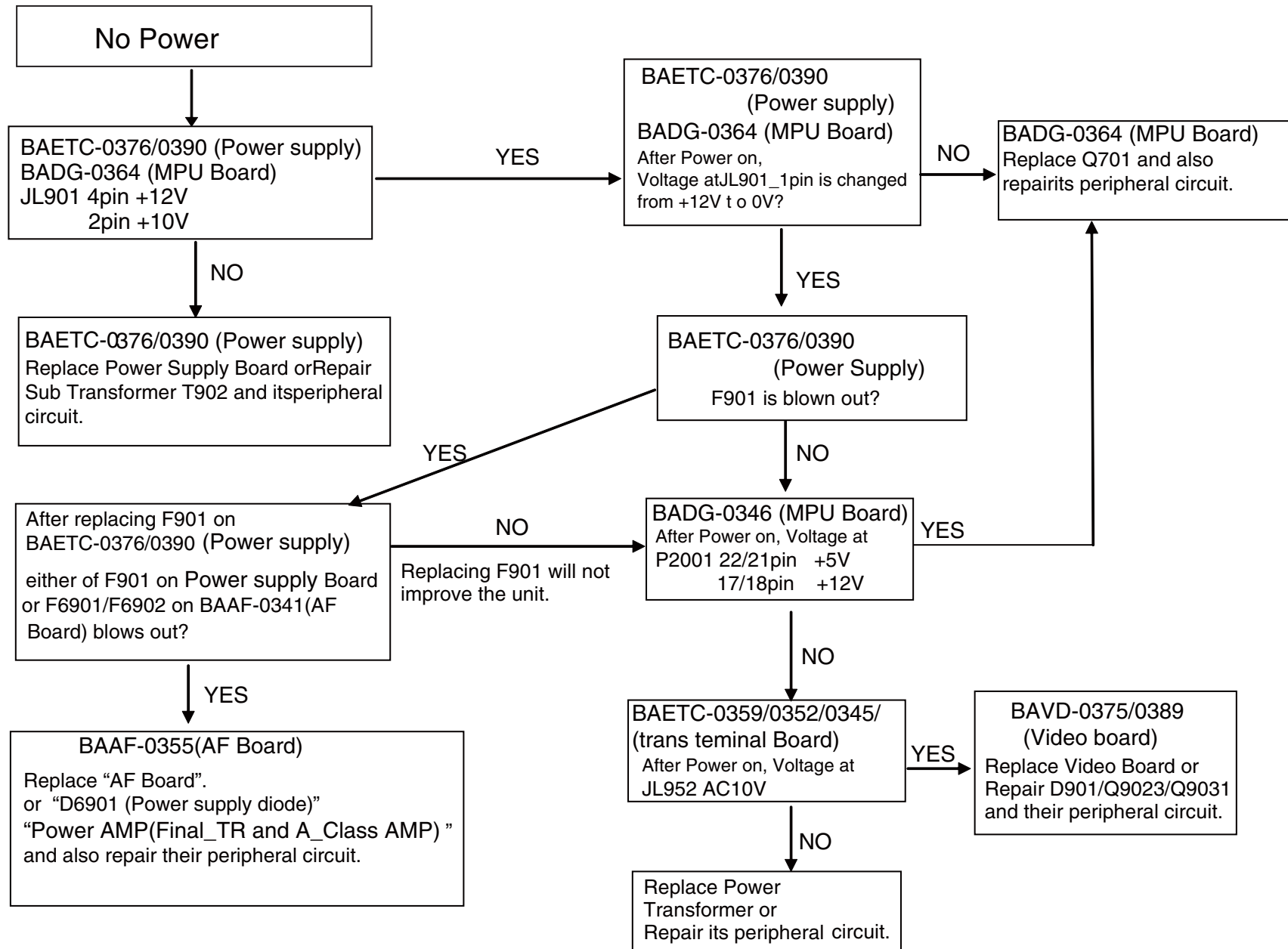

**TROUBLE SHOOT- 2**  
**No Display**

This is just for general reference and does not include every single case.  
The above waveforms are got by Oscilloscope of Maximum Horizontal Sensitivity: 100MHz.  
The results depend on the oscilloscope.

1  
2  
3  
4  
5

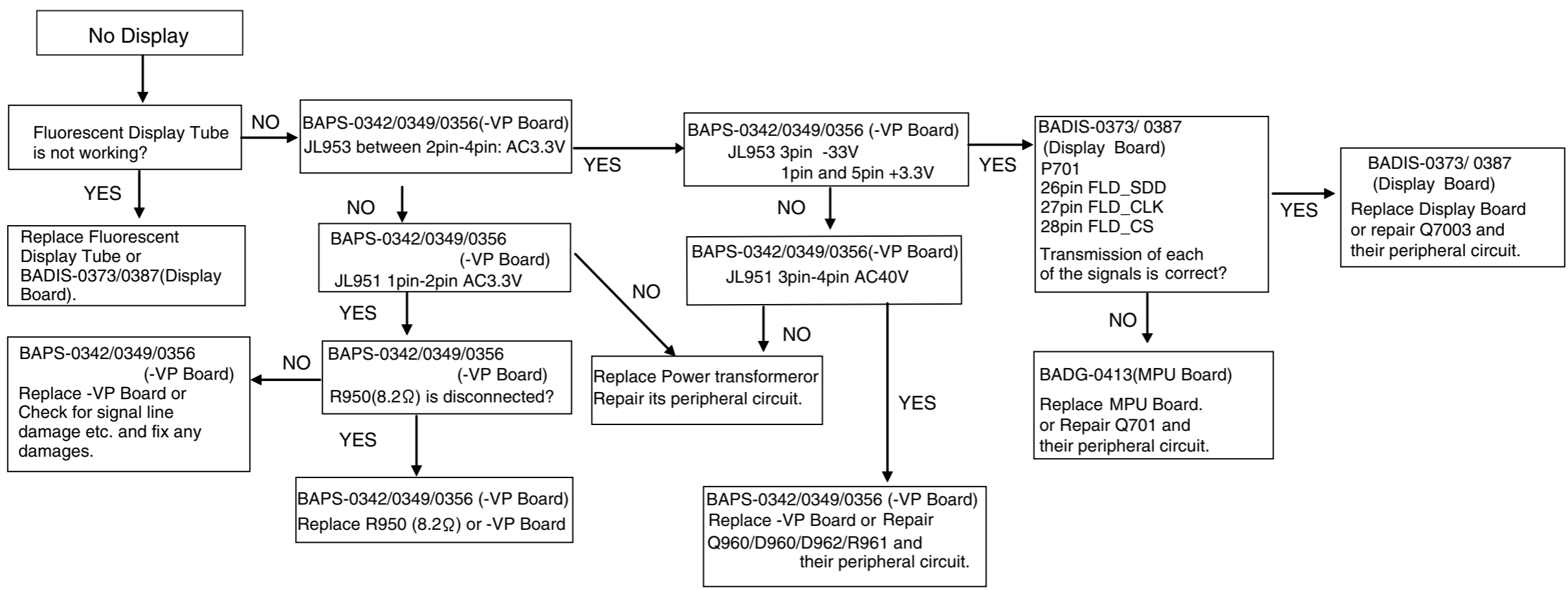

Timing of Serial Communication

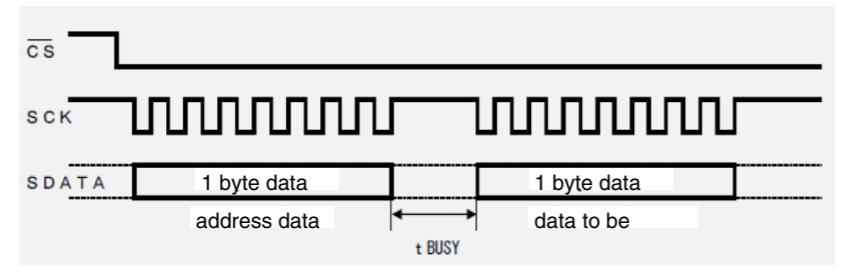

	FLD_CLK	FLD_SDD(DATA)	FLD_CS
V:1V/cm H:02Msec/cm			
V:1V/cm H:10µsec/cm			
V:1V/cm H:1µsec/cm			

**TROUBLE SHOOT-3**  
**No Sound**

Note:  
This is just for general reference and does not include every single case.  
The above waveforms are got by Oscilloscope of Maximum Horizontal Sensitivity: 100MHz.  
The results depend on the oscilloscope.

central lead wire of the resistance

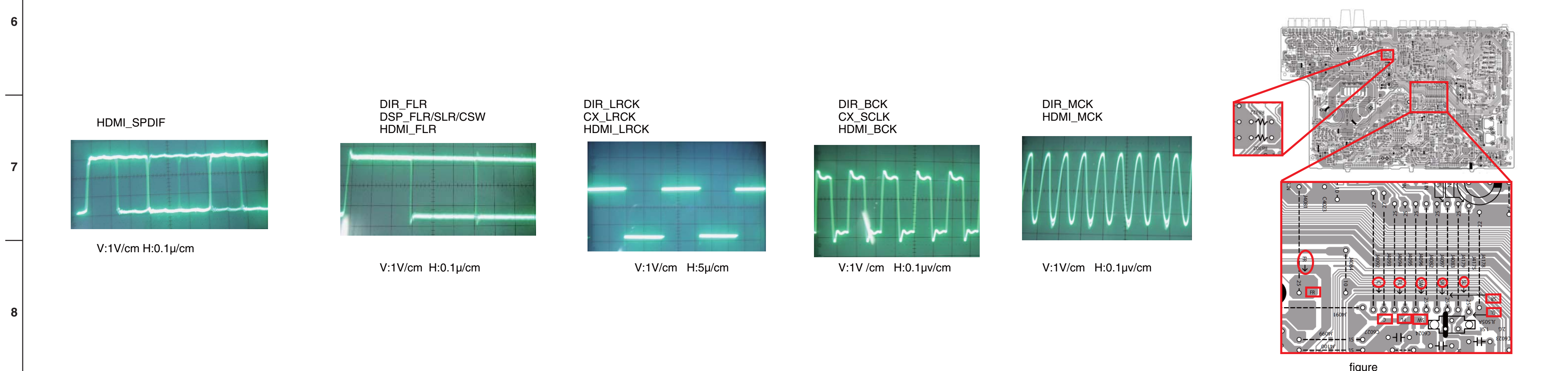
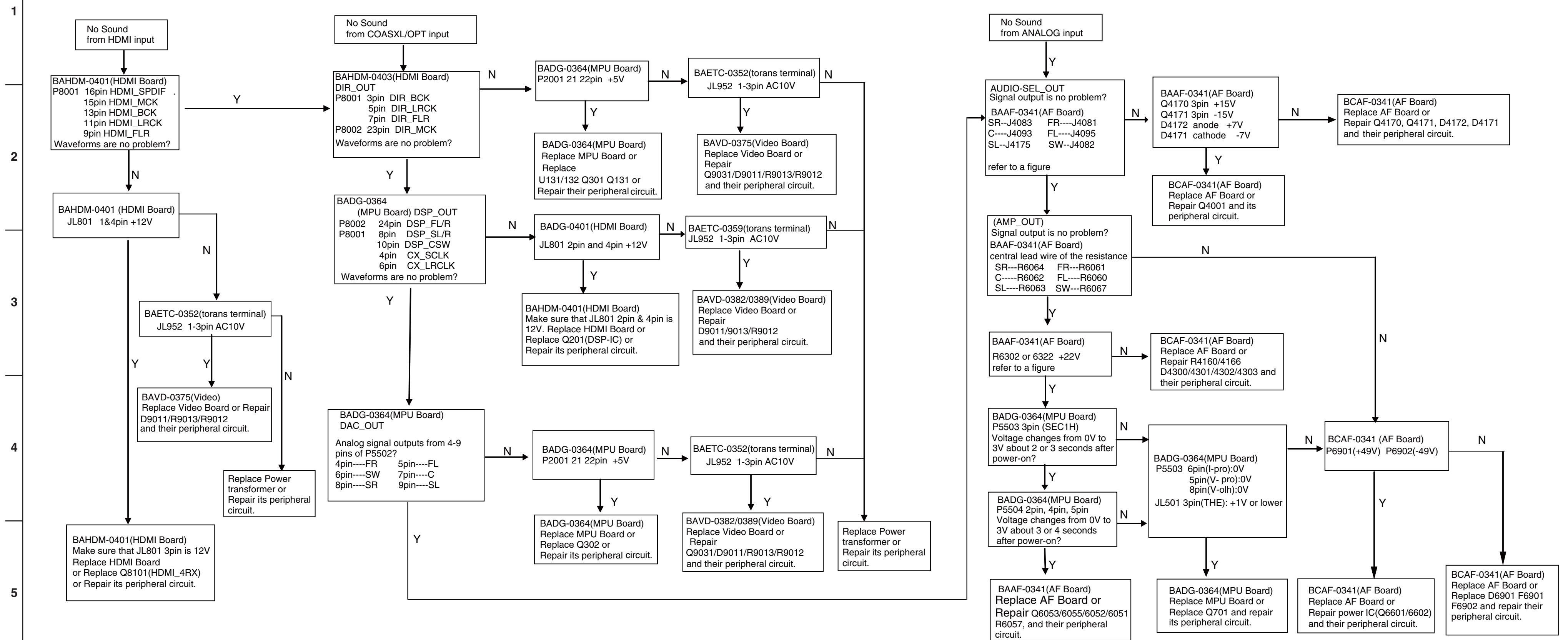

## TROUBLE SHOOT-4

### No Pictuer

Note:

This is just for general reference and does not include every single case.

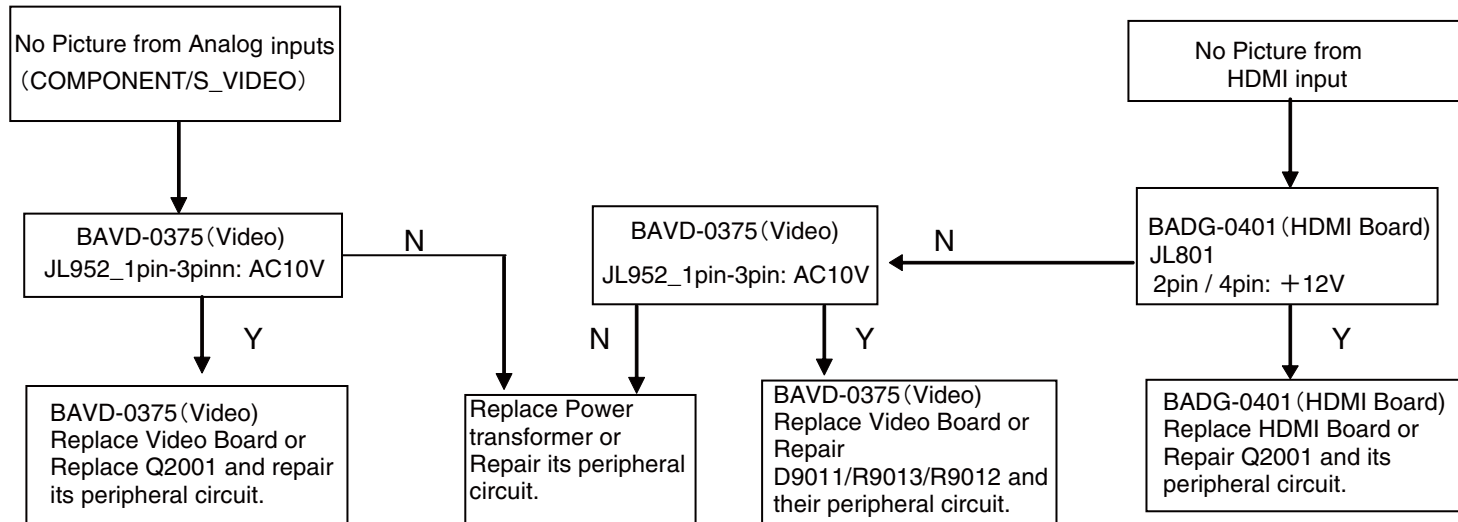

Reference materials

BLOCK DIAGRAMS (HDMI Video & Digital Audio Section)

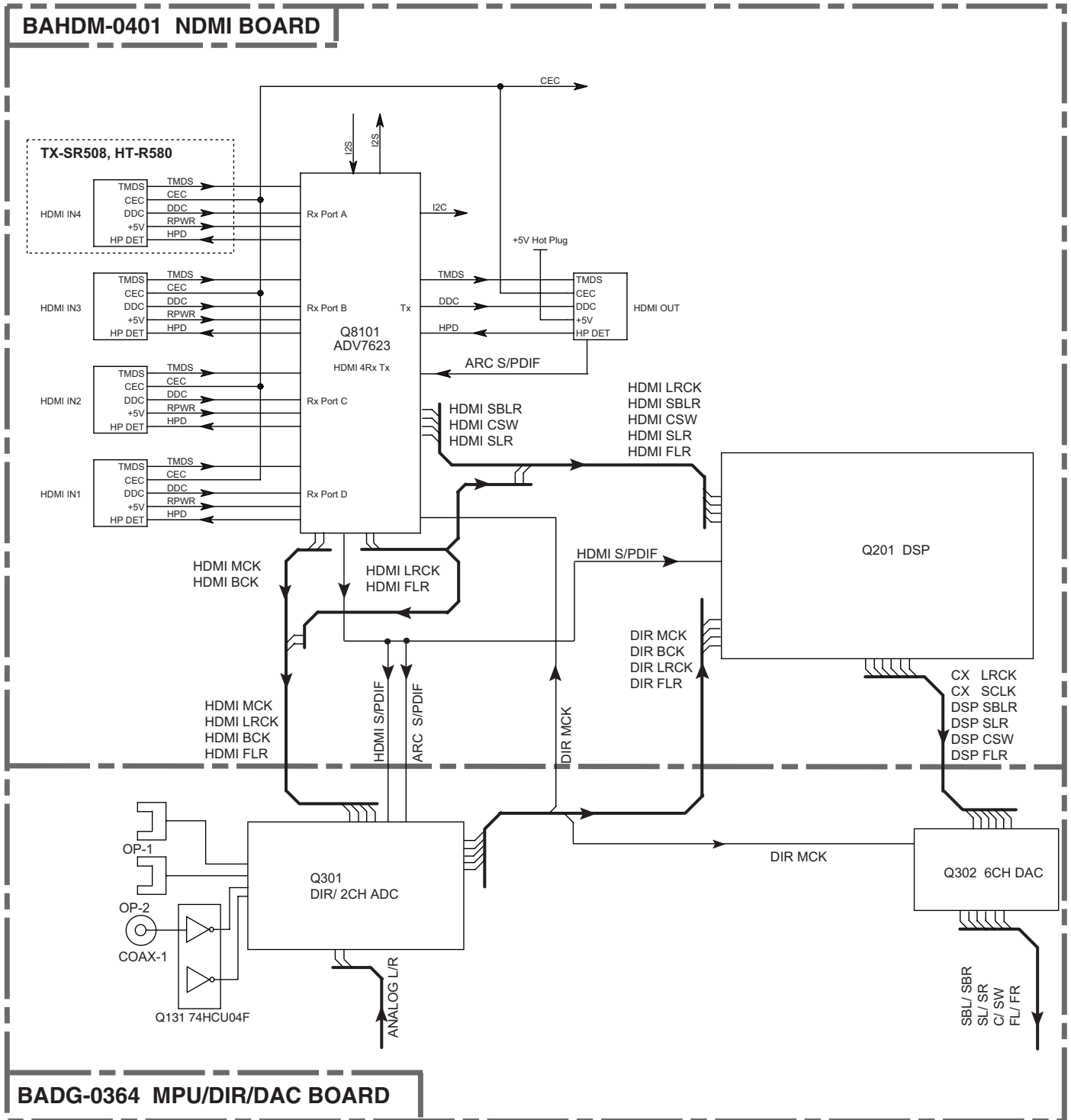

Reference materials, (protect detection)

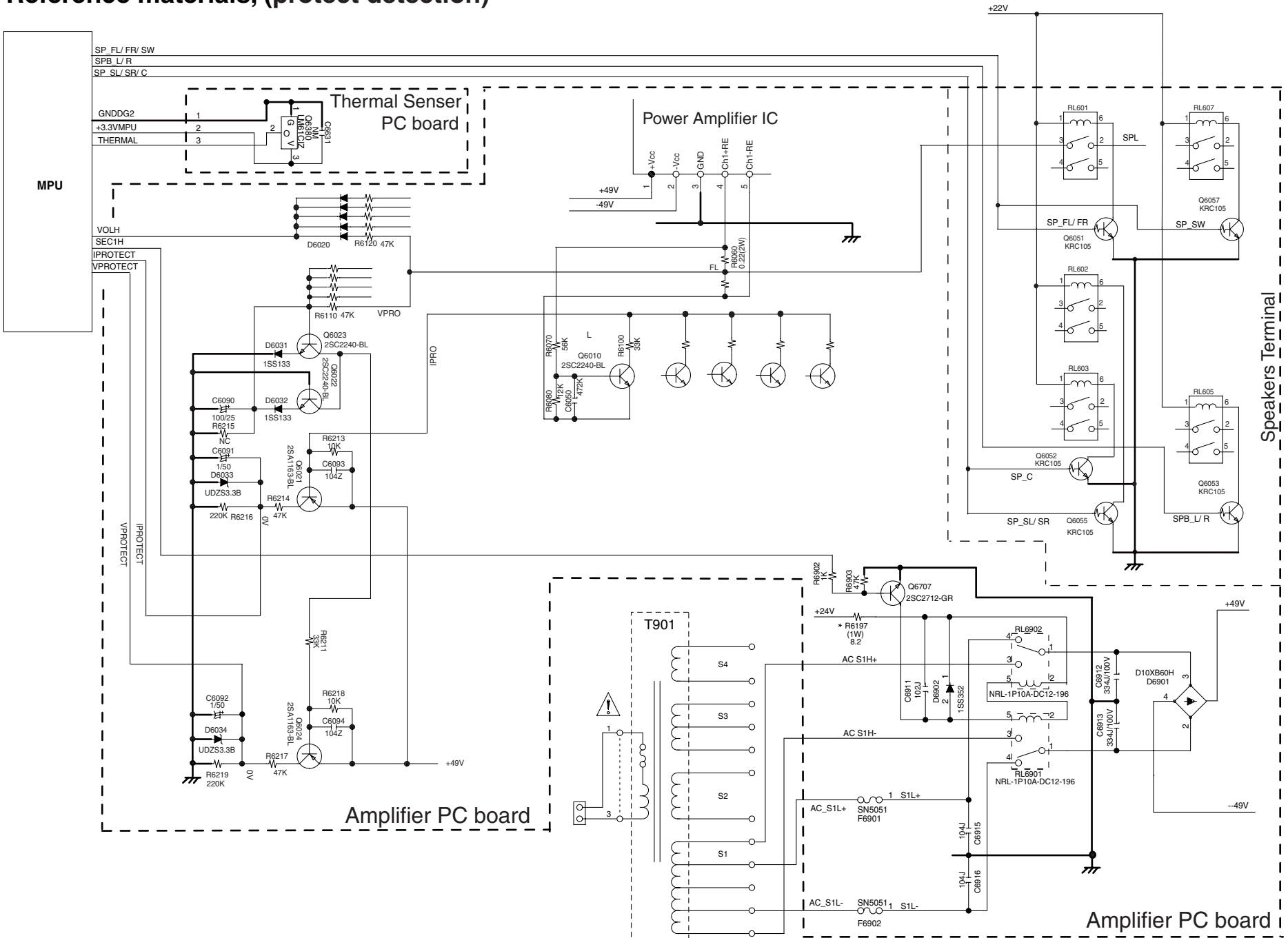

## MAIN/DSP Update Procedure-1 (How to check FW Version)

### [NOTE] FW version combination

- \* OSD FW cannot be updated.
- \* Combination of "OSD\_FW and Main\_FW" has limitation .
- \* **Do not use combination except the list.**

FW Version Combination "As of September, 2010"

	Main	DSP	OSD	marking
1st Lot	1.04	1.00	1.00	NO
Later Lots	1.05	1.01	1.01	A
	1.06			B
	1.07			C
	1.08	1.02		D
	1.09			E

OSD menu will not appear. Before FW UPdate. check the versions of FWs.

marking is the S/N end

- \* To upgrade OSD FW version,  
Replace Q8105 SPI\_MEMORY "EN25Q32A-100HIP" or HDMI Board.

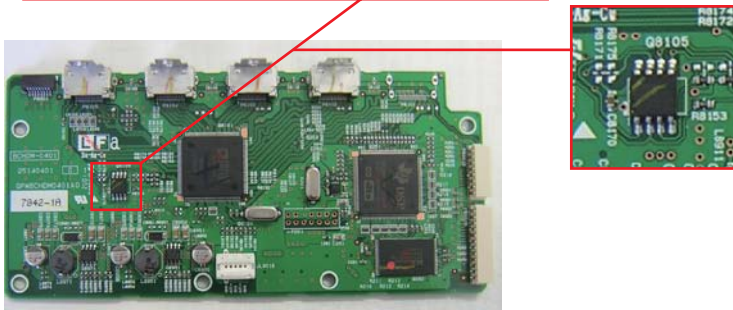

### To check FW Versions on the monitor,

While the unit is on, hold down [DISPLAY] and the press [ON/STANDBY].  
FW Versions of Main/DSP/OSD will be shown on the monitor like below.

Version Information	
Main:	1.07/10413AL
DSP:	1.02/10419a38
OSD:	1.01/10204A0
CHECKSUM:	27D3879D

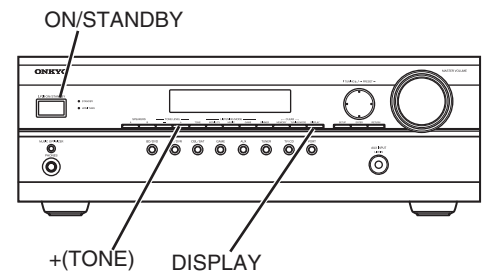

### To check FW versions on Front Display,

1. While the unit is on, hold down [DISPLAY] and the press [ON/STANDBY].  
Main FW Version will be shown on Front Display.  
e.g. M:1.07/10413AL — \* It depends on the version.
2. While Main FW Version is shown, press [+ (TONE)].  
DSP FW Version will be shown on Front Display.  
e.g. D:1.02/10416a38 — \* It depends on the version.

OSD FW Version will not be shown on Front Display.



## MAIN/DSP Update Procedure-2

### [NOTE: See MAIN/DSP Update Procedure-1]

\*Combination of "MAIN\_FW and OSD\_FW" has limitation.

\*OSD FW cannot be updated.

### Preparation for Update

1. PC (Personal Computer) which can play back wav files and output digital audio signal under Windows XP.
2. Software: Given wav-formatted FW Store it in the PC in advance (PC Update) or burn a CD-R with it as a music disc (CD Update).
3. Connection: DIGITAL (OPTICAL/COAXIAL) ourput of PC/CD Player --> DIGITAL (OPTICAL-1/COAXIAL-1) INPUT of TX-SR608 etc.

\* PC needs to be able to handle wav files and output digital audio signal.

\* For wav-compatible PCs which do not output audio signal at the above specification, use a commercially-available USB-AUDIO interface unit. e.g. Onkyo-made ND-S1

\* PC needs to run Windows XP. Windows Vista and Windows 7 do not work.

\* Set wave Volume to Maximum including Volume Control in Control Panel.  
For further information, please see Owner's manual of your PC.

Control Panel  
--> Sounds and Audio Devices  
--> Volume tab  
--> Advanced  
--> Turn all the levels to Max.

\* Instead of PC, CD players with DIGITAL output terminal can be used.

Note: CD players need to output digital audio signal .

Some CD players and DVD players are not suitable for update because they process audio signal to output.

Burn a CD-R as music disc.

### Connection Example

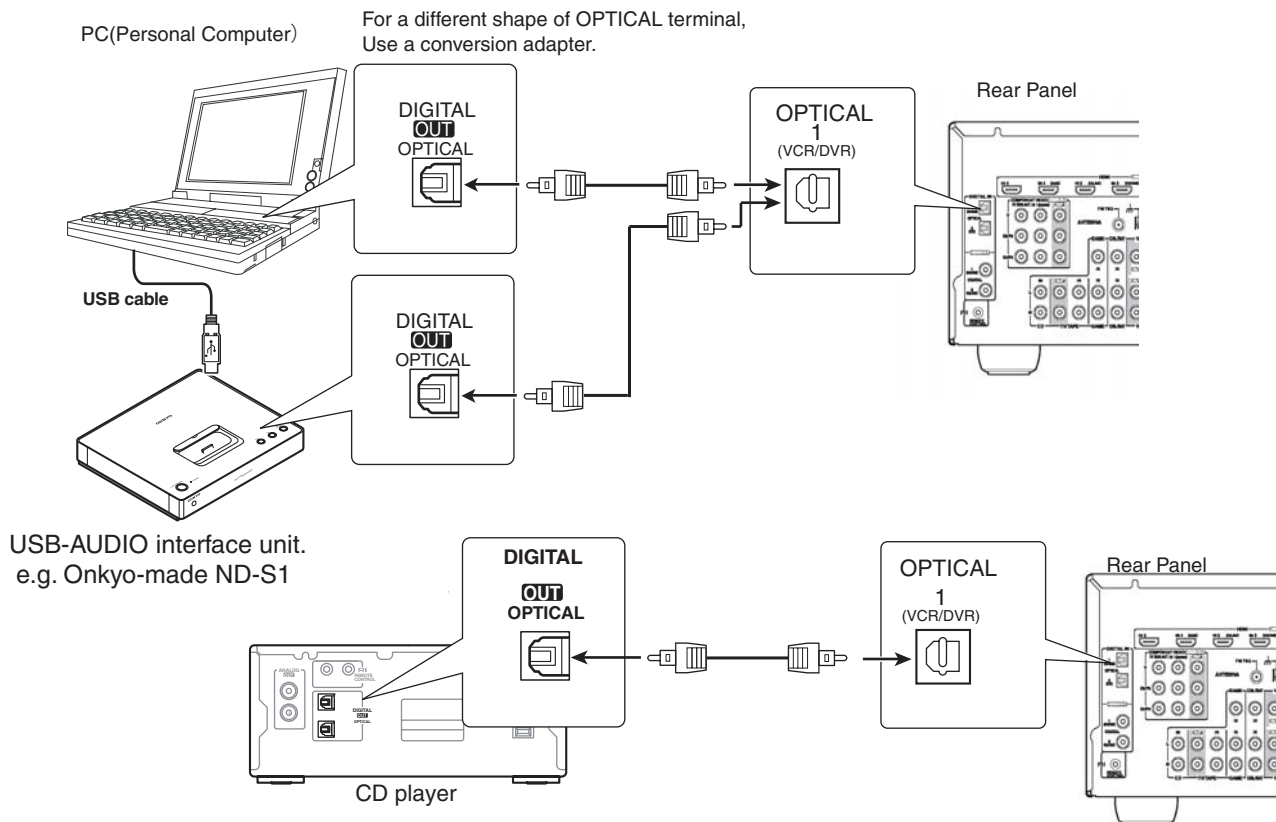

#### <NOTE 1>

"Writing" will not be shown even more than about 15 seconds passed after starting playback, audio signal does not output at Sampling frequency:44.1kHz. Check the connection and settings and try again. When another try results in failure again, use the other update method.

#### <NOTE 2>

DURING FW UPGRADE, DO NOT TURN OFF THE UNIT. DO NOT REMOVE ANY CONNECTIONS. These operation will not allow FW Upgrade any more, and the whole board or IC will need replacing.

## MAIN/DSP Update Procedure-3

### Update Procedure

1. While the unit is on, hold down [DISPLAY] and then press [ON/STANDBY].  
Main FW Version will be shown on Front Display.

e.g. M:1.07/10413AL — \* It depends on the version.

2. While Main FW Version is shown, press [+(TONE)].  
DSP FW Version will be shown on Front Display.

e.g. D:1.02/10416a38 — \* It depends on the version.

3. While DSP FW Version is shown, press [RETURN].

TOTAL / AUTO

- \* ◀TUNING▶ key changes "AUTO" ▶ "COAX1" ▶ "OPT1."  
( "AUTO" means "COAX1" or "OPT1" will be automatically detected.)
- \* ▲TUNING▼ key changes "TOTAL"▼"MAIN"▼"DSP"  
( TOTAL = MAIN+ DSP )

4. When MAIN and DSP FWs are upgraded at the same time, select "TOTAL / AUTO" and press "ENTER."  
For separate upgrade, select "MAIN" or "DSP" and press "ENTER."

S/PDIF Update..

5. PC upgrade: Play back the stored wav file in your PC.  
CD upgrade: Play back the FW CD-R with the connected CD player. It takes about 15 minutes.

**[NOTE]** Make sure that "PCM" is shown before starting playback.  
About 15 seconds later, the message will change from **S/PDIF Update...** to **Writing...**  
When "Writing..." will not be shown, the output music data is not correct.  
Check the connection and settings.

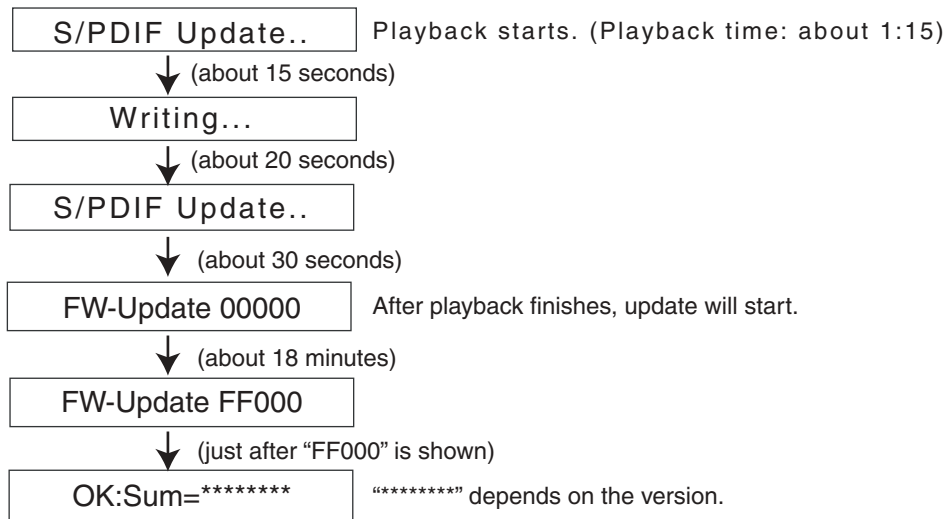

6. Unplug AC cord and plug it again. Press [ON/STANDBY].

Clear

7. Make sure that "Clear" is shown and the unit is turned into the Standby mode.
8. Make sure that the FW versions are the latest.

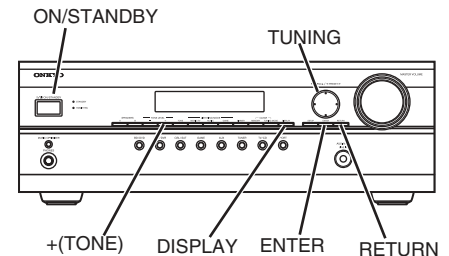

EXPLODED VIEW

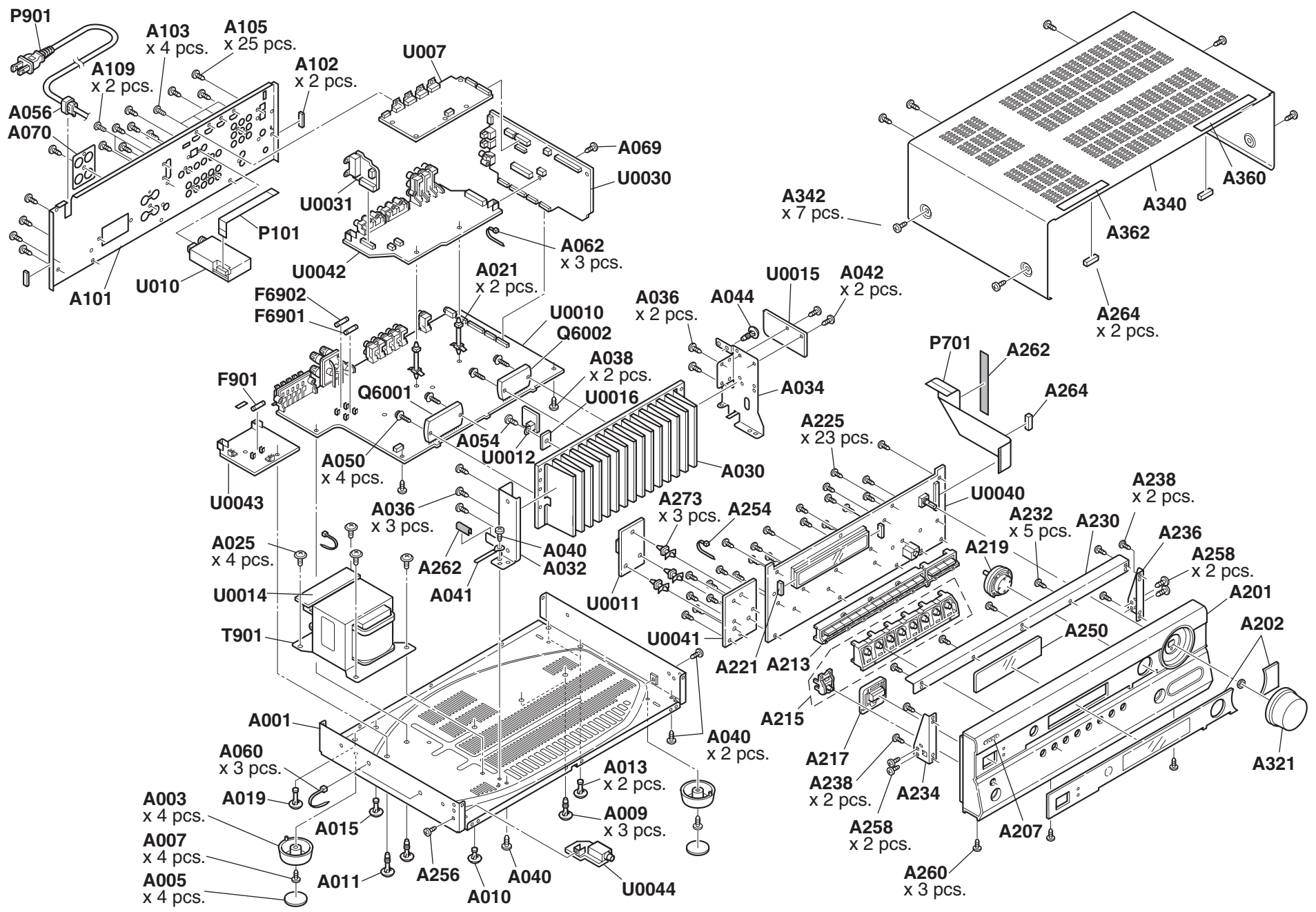

WIRING DIAGRAM

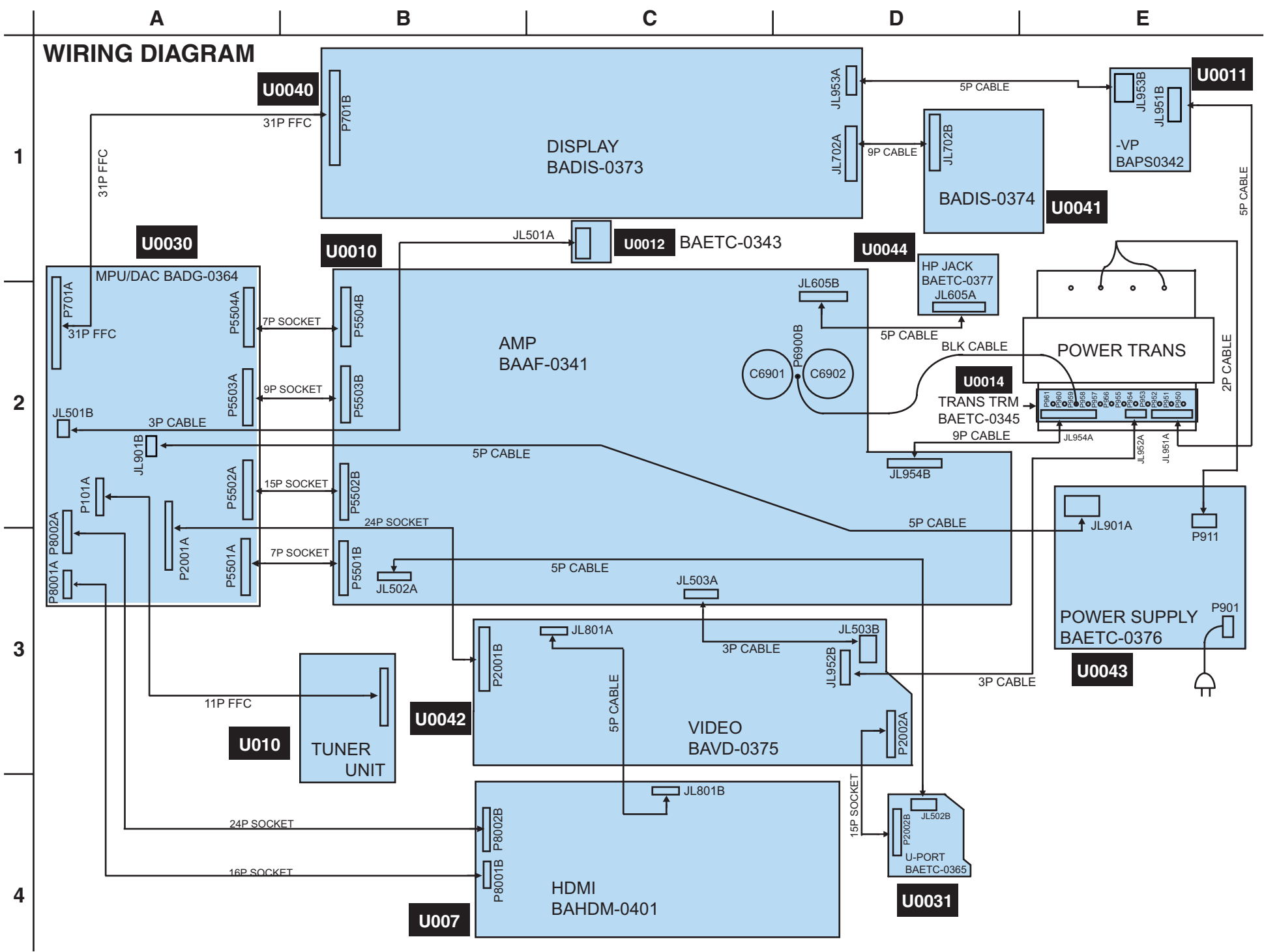

SCHEMATIC DIAGRAMS-1a  
BLOCK DIAGRAM , AUDIO SECTION

AUDIO ANALOG SIGNAL(TV/CD)      DIGITAL AUDIO SIGNAL(OPT-1)  
FRONT L      FRONT R

1  
2  
3  
4  
5  
6  
7  
8

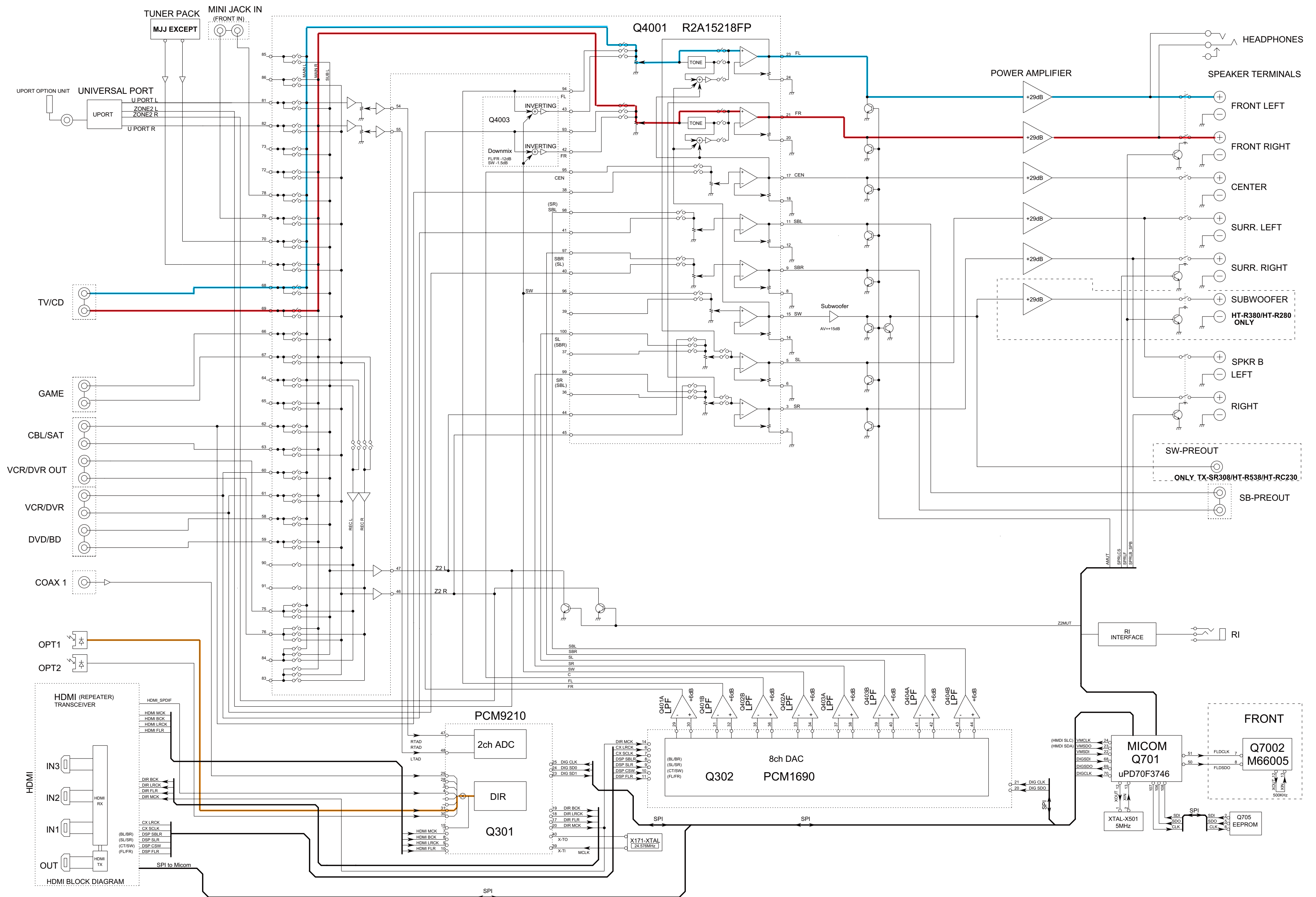

**SCHEMATIC DIAGRAMS-2**

**Video BLK Section**

1  
2  
3  
4  
5  
6  
7  
8

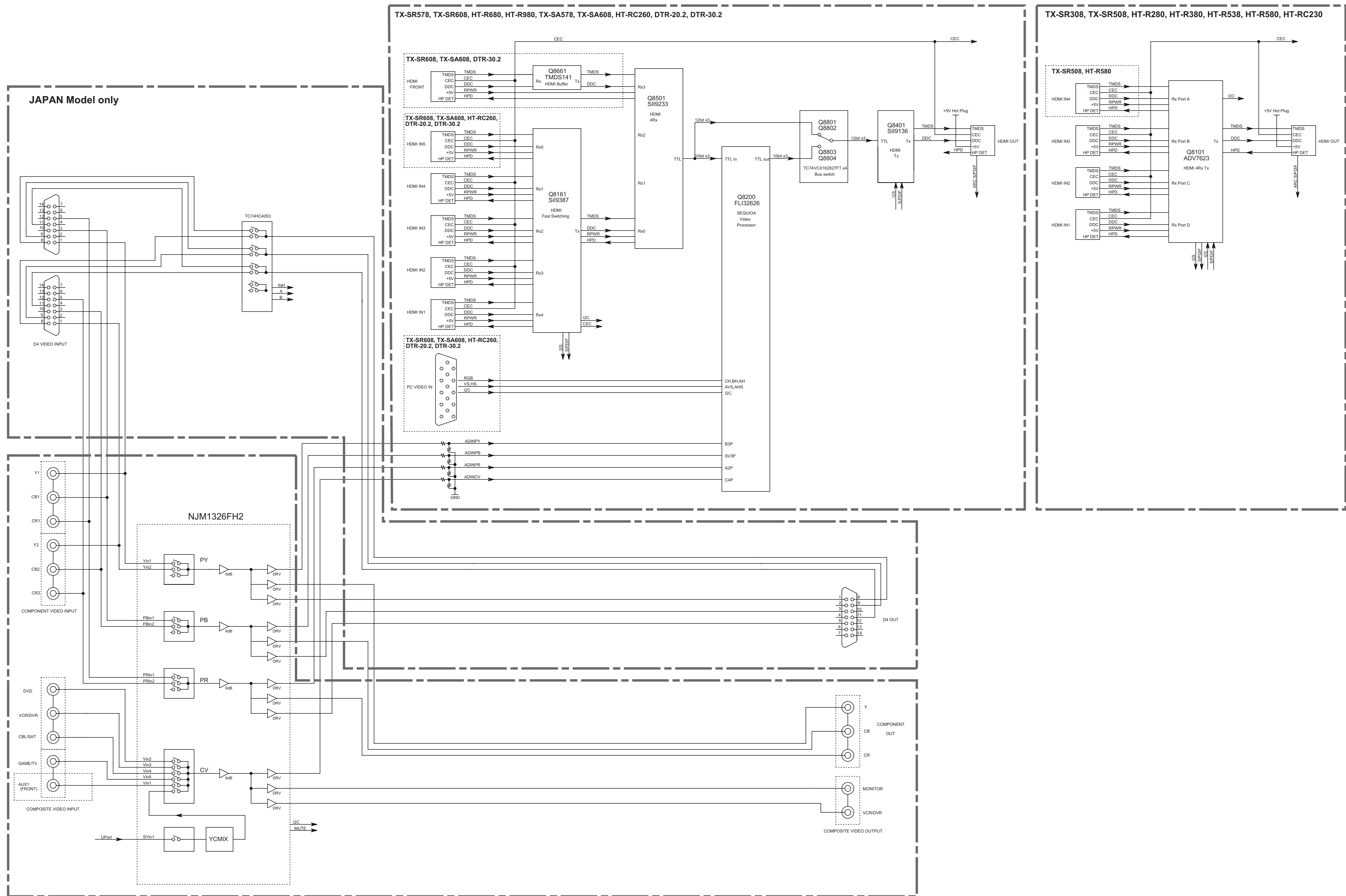

SCHEMATIC DIAGRAMS-3a

Audio INput Section

AUDIO ANALOG SIGNAL(TV/CD)

FRONT L

FRONT R

U0010 AMP (IC), ASP PC BOARD BAAF-0341

FROM SD-6 K-8 BADG-0364 (MPU SECTION) TO SD-9 A-3 BAETC-0365 (U-PORT SECTION) FROM SD-6 K-7 BADG-0364 (MPU SECTION) FROM SD-6 K-6 BADG-0364 TO SD-4a K-5 BAAF-0341 (MAIN AMP) TO SD-7 K-6 BAVD-0375 (VDEO SECCION)

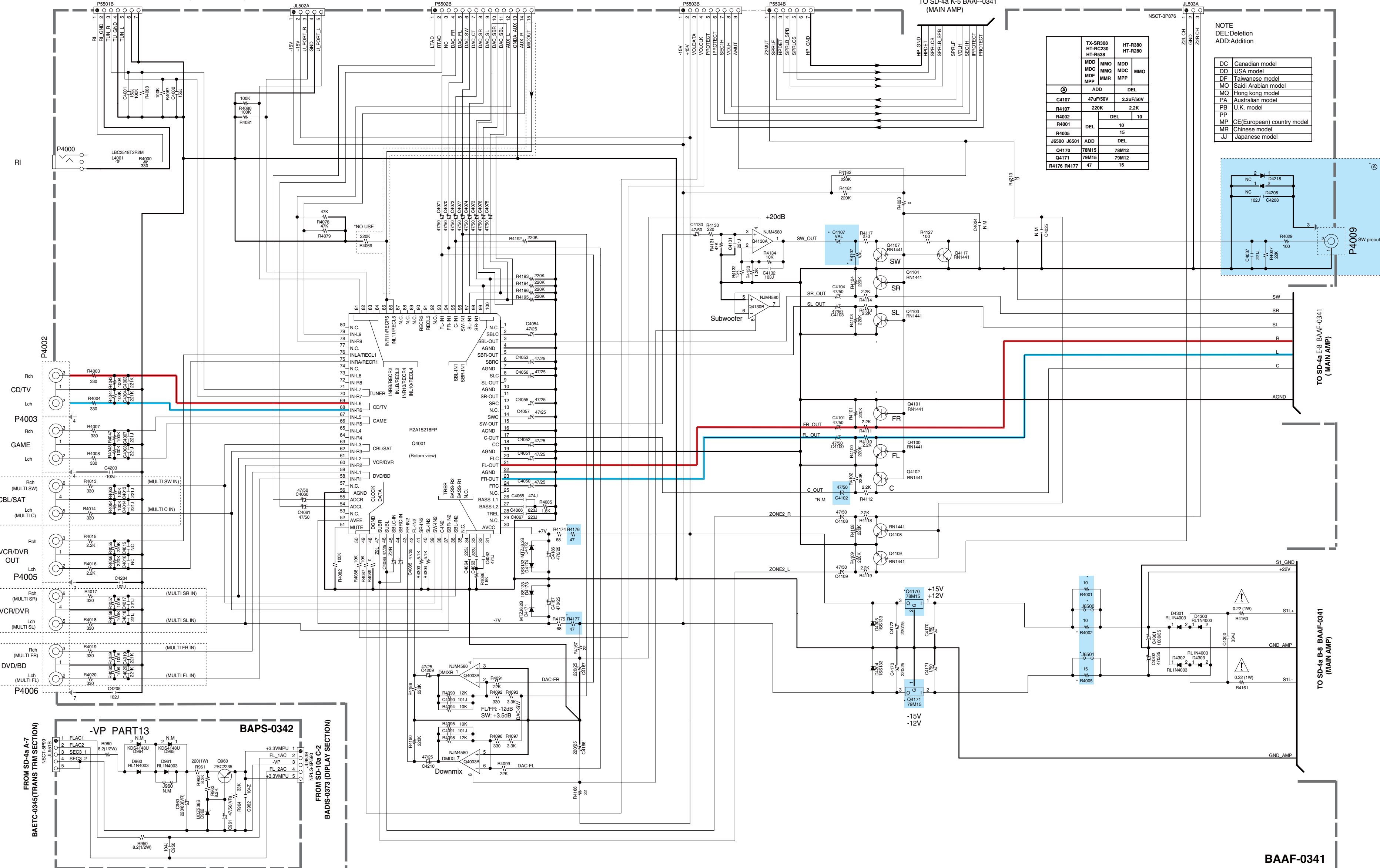

TX-SR308 HT-R280/ HT-R380 HT-R538		
MDD	MMG	
MDC	MDC	
MDF	MMR	
MPP	MPP	
ADD	DEL	
C4107	47uF50V	2.2uF50V
R4107	220K	2.2K
R4002		10
R4001	DEL	10
R4005	ADD	15
J6500 J6501	ADD	DEL
Q4170	78M15	78M12
Q4171	79M15	79M12
R4176 R4177	47	15

NOTE  
DEL:Deletion  
ADD:Addition

DC	Canadian model
DD	USA model
DF	Taiwanese model
MO	Hong kong model
PA	Australian model
PB	U.K. model
PP	CE(European) country model
MFI	Chinese model
JJ	Japanese model

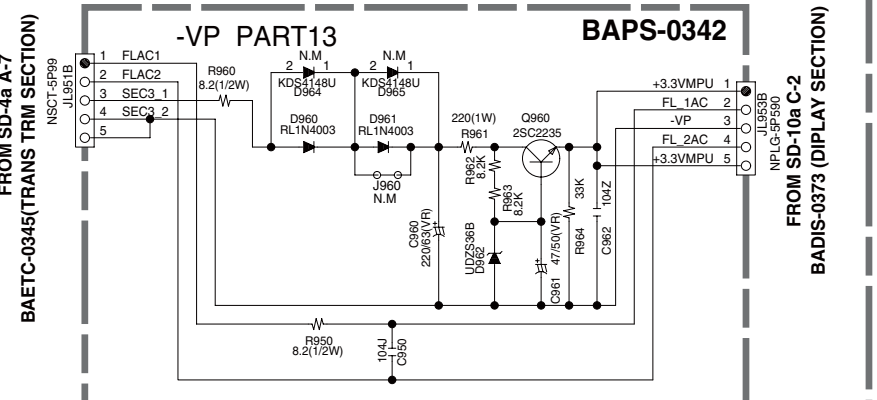
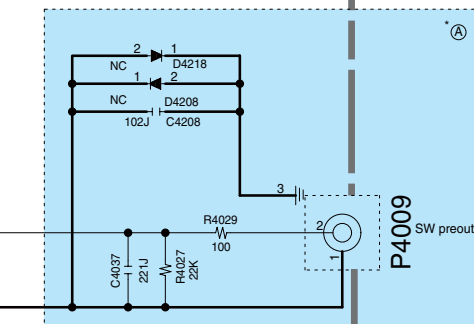

U0011 -VP PC BOARD BAPS-0342

BAAF-0341

SCHEMATIC DIAGRAMS-4a

AMP(Power) Section

AUDIO ANALOG SIGNAL  
FRONT L  
FRONT R

BAAF-0341

U0010 AMP (IC), ASP PC BOARD BAAF-0341

THE COMPONENTS IDENTIFIED BY MARK ARE CRITICAL FOR SAFETY. REPLACE ONLY WITH PART NUMBER SPECIFIED. VOLTAGE(MEASURED WITH VOLTMETER) IS DC VOLTAGE (NO INPUT SIGNAL IN HT-R340MPP). ELECTROLYTIC CAPACITORS ARE IN uF/WV. EX: 1000µF 300V3P 331 330µF 333 0.033µF. CIRCUIT IS SUBJECT TO CHANGE FOR IMPROVEMENT. ALL CAPACITORS ARE IN nF/50WV UNLESS OTHERWISE NOTED.

CAUTION FOR CONTINUED PROTECTION AGAINST FIRE HAZARD, REPLACE ONLY WITH SAME TYPE AND RATING INDICATED. ATTENTION FOR CONTINUED PROTECTION AGAINST FIRE HAZARD, REPLACE ONLY WITH SAME TYPE AND RATING INDICATED. THE SYMBOL LOCATED NEAR THE FUSE INDICATOR THAT THE FUSE USED IS IN OPERATION. THE FUSE RATED CURRENT MUST BE AT LEAST AS HIGH AS THE RATED CURRENT OF THE FUSE INDICATED. THE FUSE RATED CURRENT MUST BE AT LEAST AS HIGH AS THE RATED CURRENT OF THE FUSE INDICATED. THE FUSE RATED CURRENT MUST BE AT LEAST AS HIGH AS THE RATED CURRENT OF THE FUSE INDICATED.

NOTE DEL:Deletion ADD:Addition

DC	Canadian model
DD	USA model
DF	Taiwanese model
MO	Saudi Arabian model
MQ	Hong kong model
PA	Australian model
PP	UK model
MP	CE(European) country model
MR	Chinese model
JJ	Japanese model

	TX-SR308 / HT-R538	HT-R380/ HT-R280
	HT-RC230	
	MDD MPP	MDD MPP
	MDC MDC	MDC MDC
	MDF MMR	
(A)		
(B)		
(C)		
(D)		
(E)		
Q6002	STK-442-530-E	STK-443-530-E
J6477	ADD	DEL
P6001	NTM-10PDM	NTM-12PDM
C6901	8200u 56V	8200u 63V
C6902	8200u 63V	8200u 63V
F6901	8A	
F6902	125V	
C6800		
C6801	102J 472J	102J 472J
C6802		
C6803		
C6804		
C6807	DEL	
C6808	102J 472J	
C6809		
R6316	DEL	ADD
J6455	ADD	DEL
Q6057	DEL	ADD
R6322	47(1W)	22(1W)

\*Q6001/Q6002 Terminal Voltage

PIN NO.	Q6001/Q6002
1	+49V
2	-49V
4,5,6,7	0V
17,18	0V
8	-46V
9	-49V
12	-45V
10,11,13,14	-0.16V
15,16	-0.16V

(1/16A for TX-SR308 (Q6002))

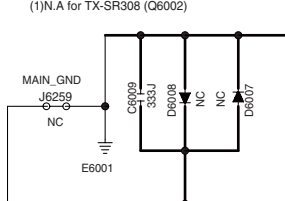

STK-443-530-E: TX-SR308,HT-R380,HT-R538

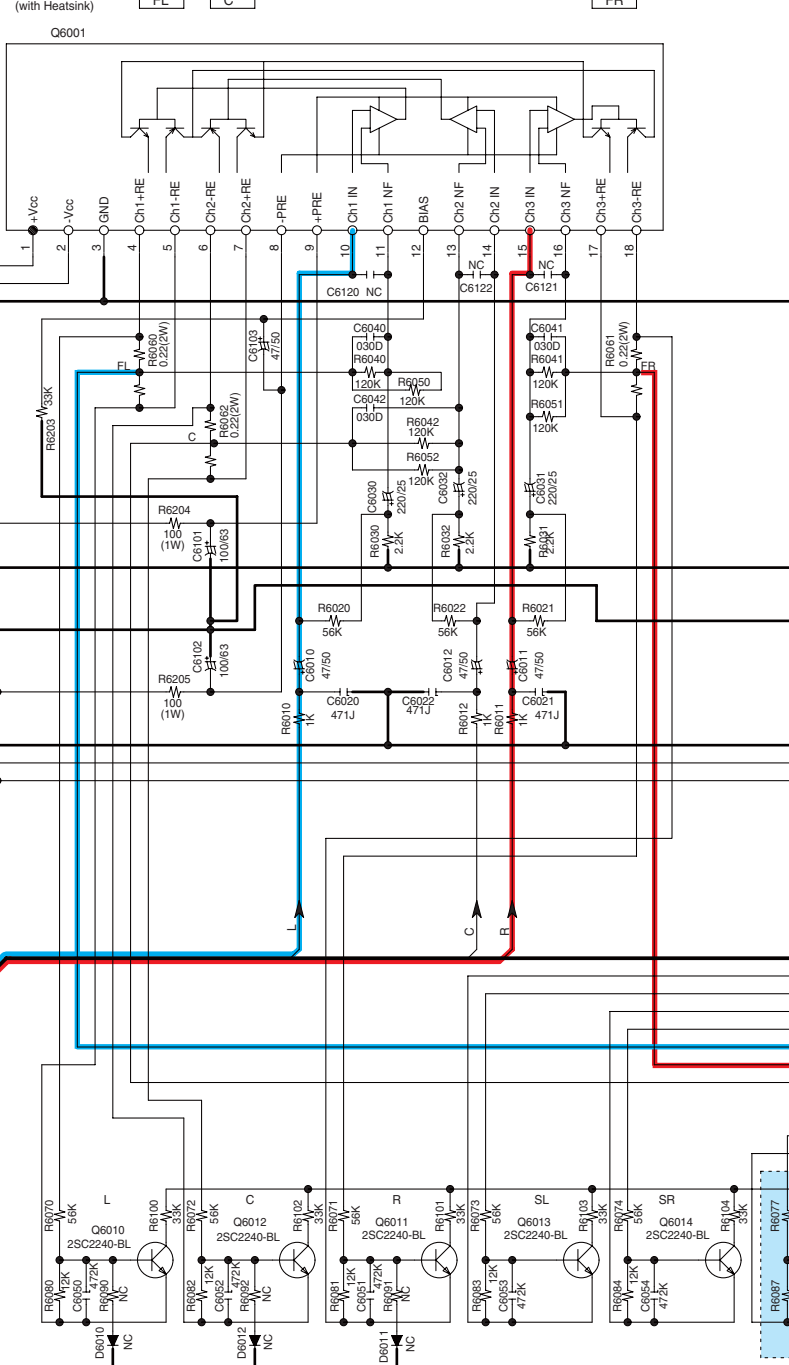

STK-443-530-E: HT-R380  
STK-442-530-E: TX-SR308/HT-R538

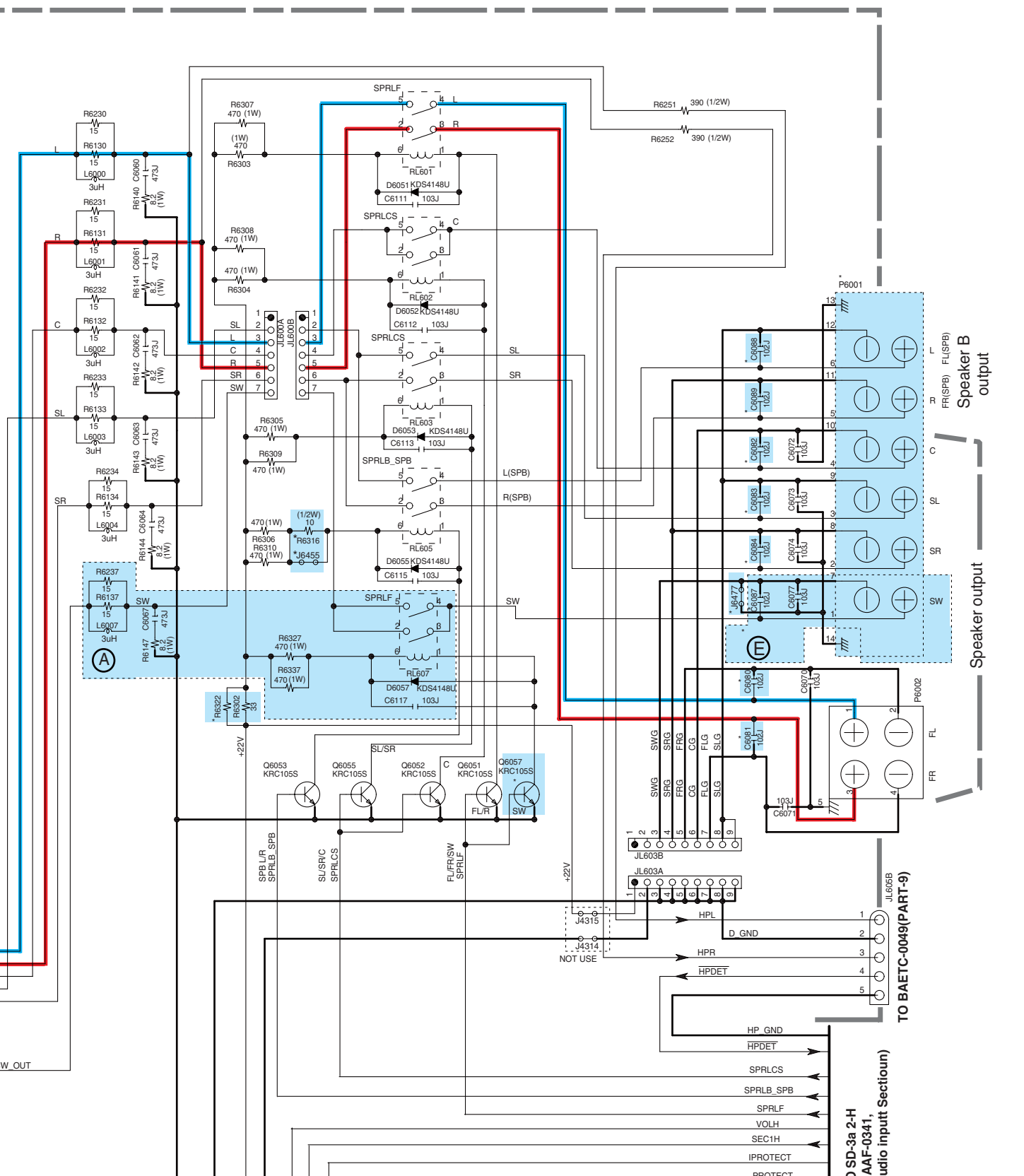
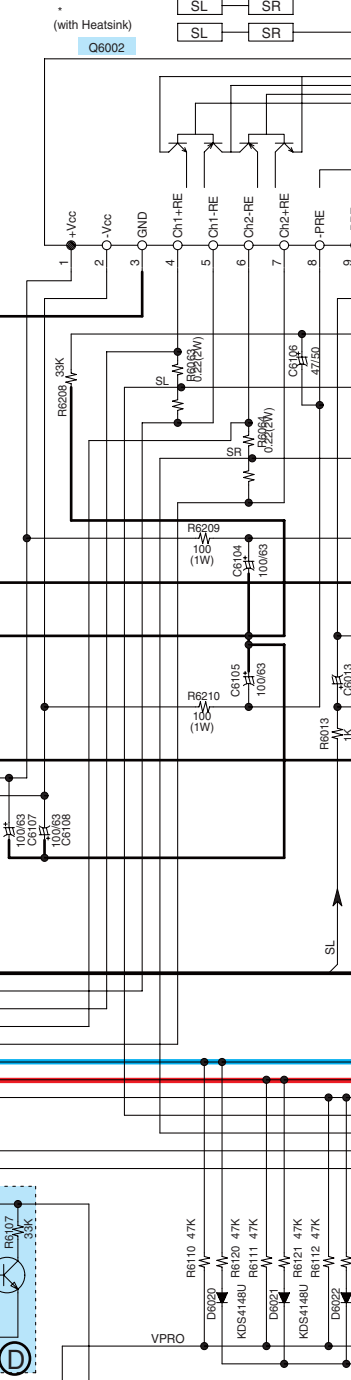

U0010 THERMAL SENSER PC BOARD BAETC-0343

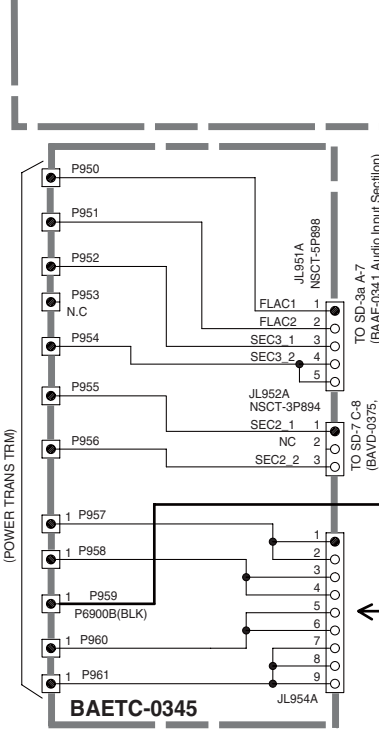
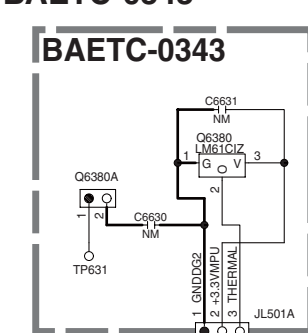

U0010 TRANS TRM PC BOARD BAETC-0345

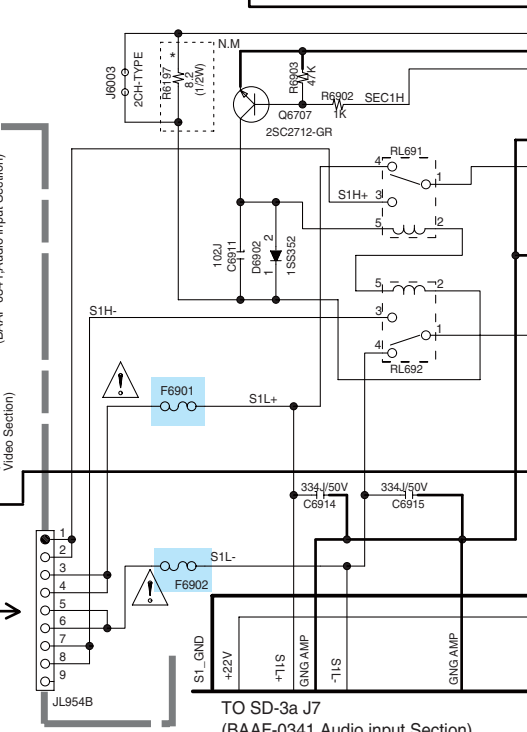

TO SD-3a J4 (BAAF-0341, Audio input Section)

TO SD-3a 2-H (BAAF-0341, Audio input Section)

TO SD-9 K4 (BADG-0364 MPU Section)



SCHEMATIC DIAGRAMS-6

MPU/ DIR/ DAC Section

U0030

MPU, DIR, DAC PC BOARD  
BADG-0364

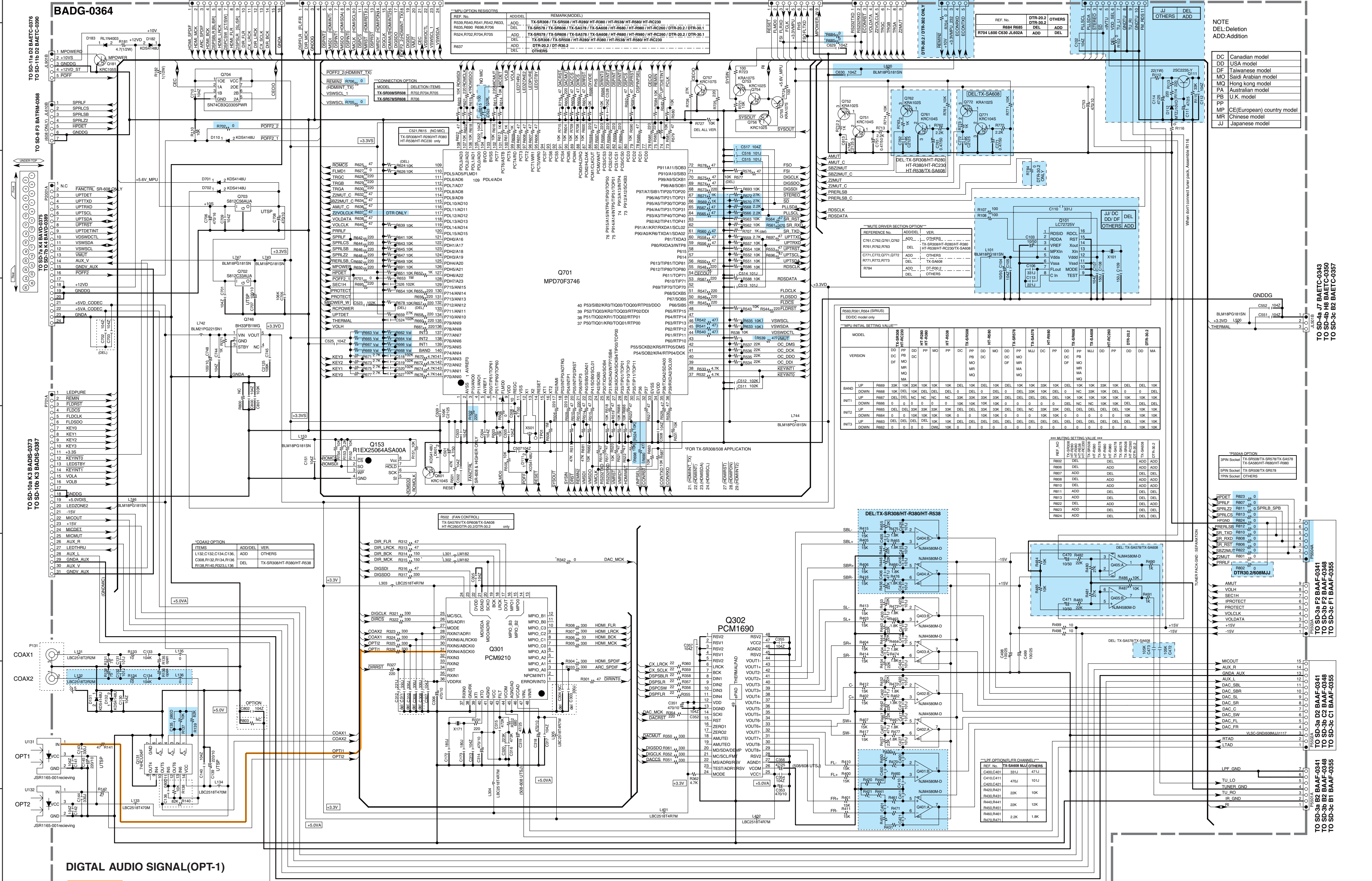

SCHEMATIC DIAGRAMS-7

Video Section

**U0042** VIDEO PC BOARD BAVD-0375  
**U0042** VIDEO PC BOARD BAVD-0389 (DTR-20.2/ 30.2 Only)

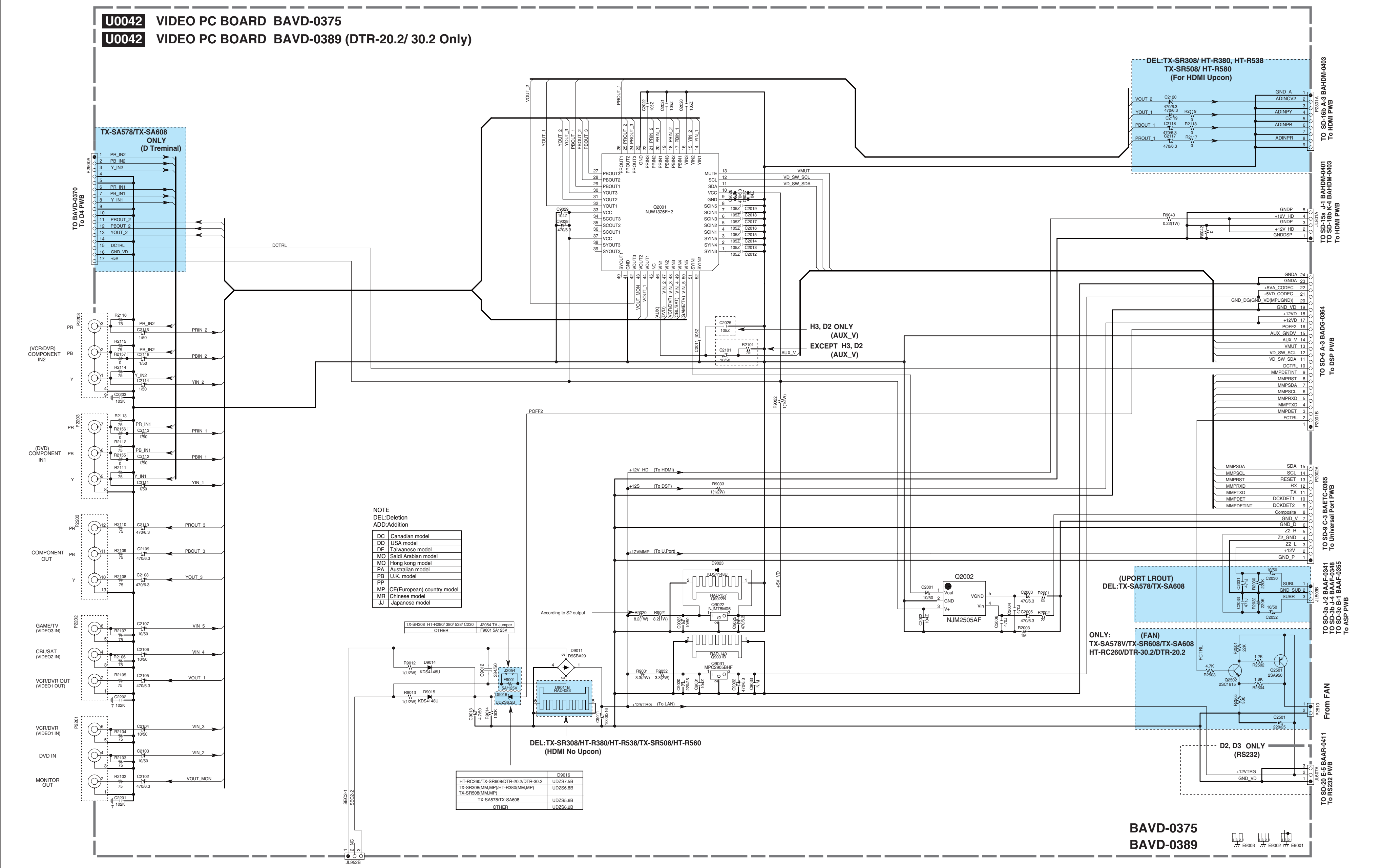

NOTE  
 DEL: Deletion  
 ADD: Addition

DC	Canadian model
DD	USA model
DF	Taiwanese model
MO	Saudi Arabian model
MO	Hong kong model
PA	Australian model
PB	U.K. model
PP	
MP	CE (European) country model
MR	Chinese model
JJ	Japanese model

TX-SR308/HT-R280/380/C230	J0054 TA Jumper
OTHER	F9001 SA125V

HT-RC260/TX-SR608/DTR-20.2/DTR-30.2	D9016
TX-SR308/MM-MP/HT-R380/MM-MP	UDZ56.BB
TX-SR508/MM-MP	UDZ56.BB
TX-SA578/TX-SA608	UDZ56.BB
OTHER	UDZ56.2B

BAVD-0375  
 BAVD-0389

TO SD-4a B-8 BAPS-0342  
 TO SD-3b J-7 BAPS-0349  
 TO SD-4c B-3 BAPS-0356  
 TO PTRANS FIX PWB

TO SD-16A-A-3 BAHDM-0403  
 To HDMI PWB  
 TO SD-15a J-1 BAHDM-0401  
 TO SD-16b K-4 BAHDM-0403  
 To HDMI PWB  
 TO SD-4-A-3 BADG-0364  
 To DSP PWB  
 TO SD-9-C-3 BAETC-0365  
 To Universal Port PWB  
 TO SD-3b J-4 BAAF-0348  
 TO SD-3c E-1 BAAF-0355  
 To ASP PWB  
 TO SD-3b J-2 BAAF-0341  
 TO SD-3b J-4 BAAF-0348  
 TO SD-3c E-1 BAAF-0355  
 To ASP PWB  
 FROM FAN  
 TO RS232 PWB

A

B

C

D

E

SCHEMATIC DIAGRAMS-9

U. Port Unit Section

1

**U0031 U. PORT PC BOARD BAETC-0365**

2

3

4

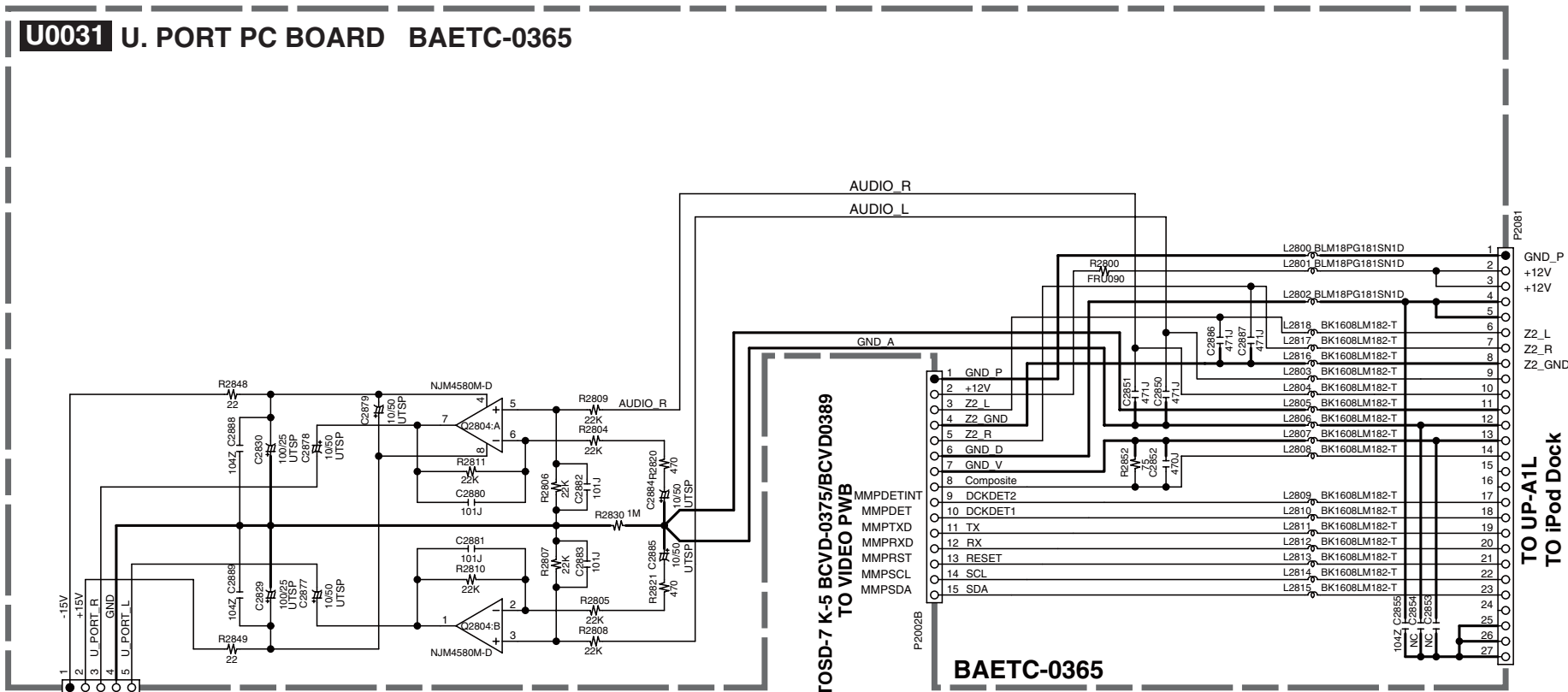

- TO SD-3a C-2 BAAF-0341
- TO SD-3b C-2 BCAF-0348
- TO SD-3c C-2 BCAF-0355
- TO Audio Input PWB

**BAETC-0365**

SCHEMATIC DIAGRAMS-10a

Display Section

1

U0044 HP PC BOARD BAETC-0377

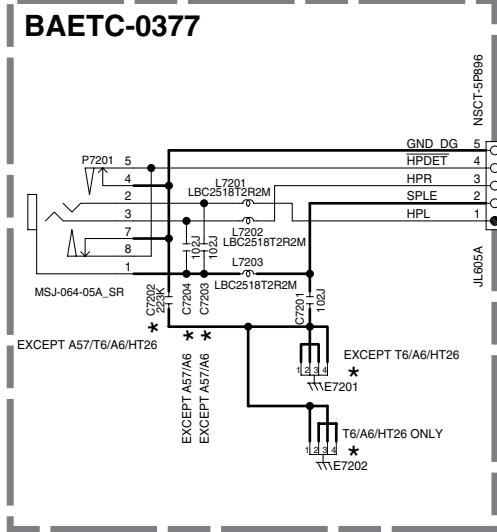

TO SD-8 B-1 BAFTRM-0368  
FROM SP-OUT PWB  
TO SD-4a K-4 BAAF-0341  
FROM AMP PWB

TO -VP PWB  
TO SD-3a C-7 BAPS-0342  
TO SD-3b C-7 BAPS-0349  
TO SD-3c C-7 BAPS-0356

NOTE  
DEL: Deletion  
ADD: Addition

DC	Canadian model
DD	USA model
DF	Taiwanese model
MO	Saudi Arabian model
MQ	Hong kong model
PA	Australian model
PB	U.K. model
PP	U.K. model
MP	CE(European) country model
MR	Chinese model
JJ	Japanese model

U0040 DISPLAY PC BOARD BADIS-0373

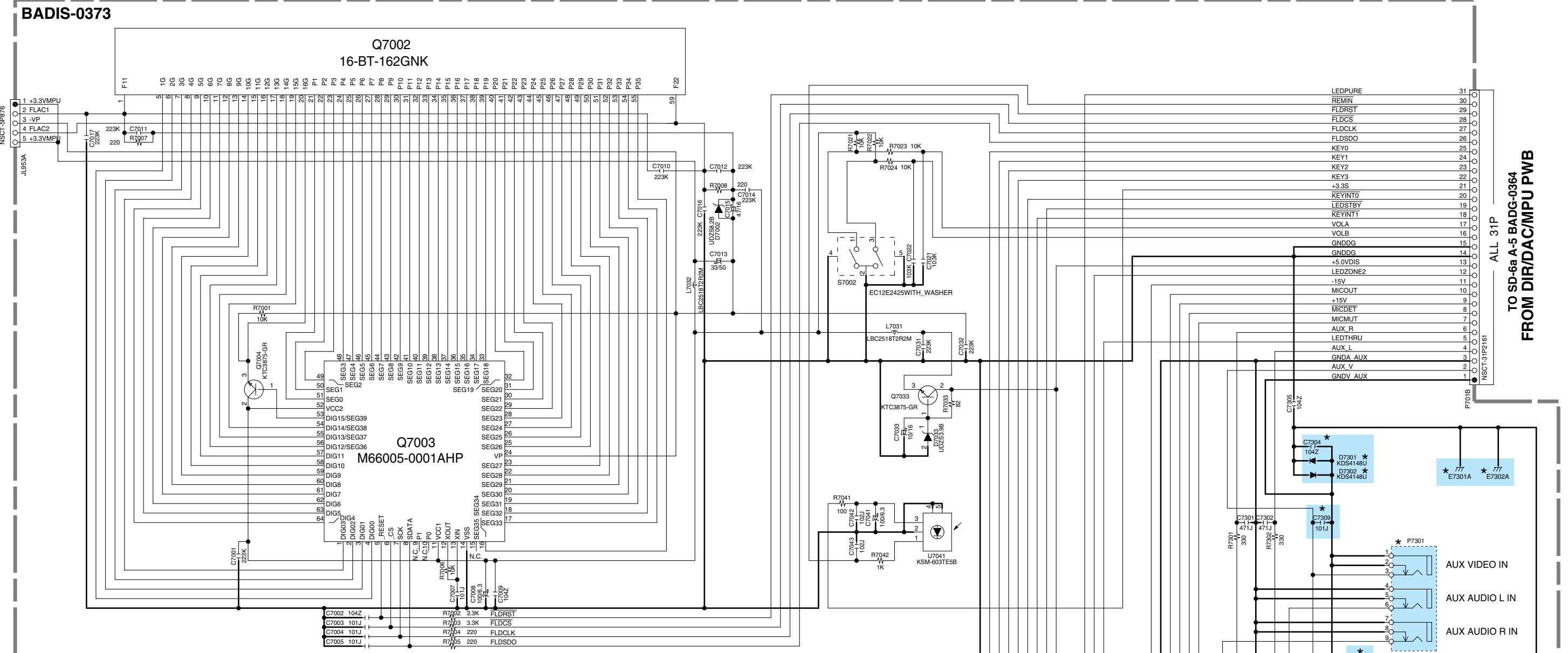

TO SD-6a A-5 BADG-0364  
FROM DIR/DAC/MFU PWB

U0041 KEY SWITCH PC BOARD BADIS-0374

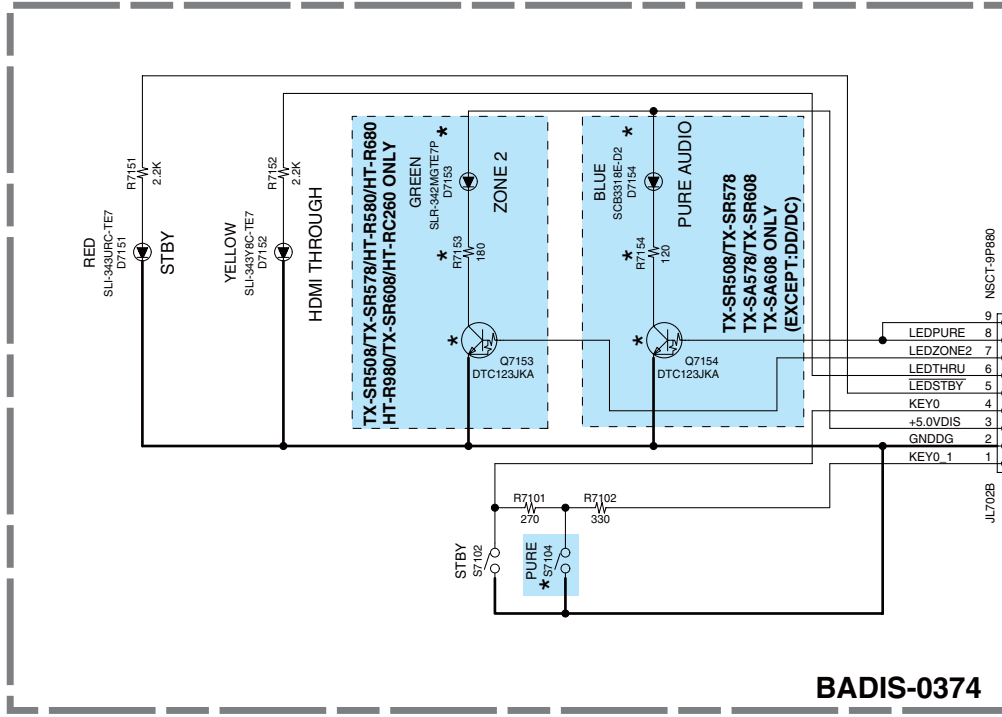

BADIS-0374

	TX-SR608 TX-SA608 HT-RC260	TX-SR308 HT-R380 HT-R538	OTHERS
C7304 C7306 C7309	ADD	DEL	ADD
D7301 D7302	ADD	DEL	ADD
E7301A	DEL	ADD	DEL
E7301	ADD	DEL	DEL
P7312 R7305	ADD	DEL	DEL
P7311 R7304	DEL	ADD	ADD
P7302	ADD	DEL	DEL
P7301	DEL	DEL	ADD

	S7106	S7108
TX-SR308	SP-A	SP-B
HT-R280/380/538/C230	ZONE-2	ZONE-2
TX-SR508/578/608	RIHD	MUSIC OPTIMIZER
HT-R580/680/980/C260		
TX-SA578/578V/608		

DEL: TX-SR608/TX-SA608/HT-RC260

ONLY: TX-SR608/TX-SA608/HT-RC260

	S7134	S7132
TX-SA578/578V	CINEMA FILTER	LATE NIGHT
TX-SA608	Re-EO	LATE NIGHT
Others	MEMORY	TUNING

CODE	R7106	R7107	R7108	R7109	R7110	R7130
DEL-HT-RC260	270	330	470	560	820	0
ADD-HT-RC260	0	270	330	470	560	820

CODE	S7114	S7116	S7118	S7130	S7122
TX-SR608/TX-SA608	U.PORT	TV/CD	TUNER	AUX	RC
HT-RC260	DEL	U.PORT	TV/CD	TUNER	AUX

	S7136
DC,DD,DF,JJ	DIMMER
Others	RT/TPT/TP

8

	TX-SR608 TX-SA608 HT-RC260	TX-SR308 HT-R380 HT-R538 HT-RC230	OTHERS
P7401 R7415	DEL	DEL	ADD
P7402 R7416	ADD	DEL	DEL

# SCHEMATIC DIAGRAMS-11



## Power Supply Sectio

### U0043 POWER SUPPLY PC BOARD BAETC-0376/ BAETC-0390

<NOTE>

DC	Canadian model
DD	USA model
DF	Taiwanese model
MO	Saudi Arabian model
MQ	Hong kong model
PA	Australian model
PB	
MB	U.K. model
PP	
MP	CE(European) country model
MR	Chinese model
JJ	Japanese model

- 印は火災、感電の危険に関与する部品の為、必ず指定部品を使用の事。
- 電圧表示は無信号時に測定した直流電圧を示す。  
(単位V、入力抵抗100KΩ/V以上の電圧計)
- 記入なきコンデンサの単位はμF/VVである。  
例 030→3pF 330→33pF 331→330pF 333→0.033μF
- 本配線図は基本配線図につき性能改善等により予告なく変更する事がある。

- \* THE COMPONENTS IDENTIFIED BY MARK  ARE CRITICAL FOR SAFETY. REPLACE ONLY WITH PART NUMBER SPECIFIED.
- \* VOLTAGE (MEASURED WITH VOLT METER) IS DC VOLTAGE. (NO INPUT SIGNAL)
- \* ELECTROLYTIC CAPACITORS (  ) ARE IN μF/VV.
- \* ALL CAPACITORS ARE IN pF/50V UNLESS OTHERWISE NOTED.
- E X ) 030→3pF 330→33pF 331→330pF 333→0.033μF
- \* CIRCUIT IS SUBJECT TO CHANGE FOR IMPROVEMENT.

#### CAUTION



FOR CONTINUED PROTECTION AGAINST FIRE HAZARD, REPLACE ONLY WITH FUSE OF SAME TYPE AND RATING INDICATED.

#### ATTENTION



AFIN D'ASSURER UNE PROTECTION PERMANENTE CONTRE LES RISQUES D'INCENDIE, REMPLACER UNIQUEMENT PAR UN FUSIBLE DE MEME TYPE ET CALIBRATION COMME INDIQUE.



THIS SYMBOL LOCATED NEAR THE FUSE INDICATES THAT THE FUSE USED IS SLOW OPERATING TYPE FOR CONTINUED PROTECTION AGAINST FIRE HAZARD. REPLACE WITH SAME TYPE FUSE. FOR FUSE RATING REFER TO THE MAKING ADJACENT TO THE SYMBOL.



CE SYMBOLE INDIQUE QUE LE FUSIBLE UTILISE EST A LENT, E POUR UNE PROTECTION PERMANENTE. N'UTILISER QUE DES FUSIBLES DE MEME TYPE. CE DERNIER EST INDIQUE LA QU LE PRESENT SYMBOLE EST APPOSE.

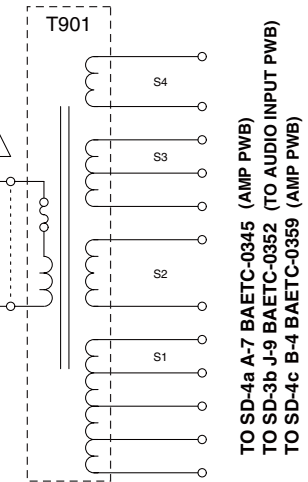
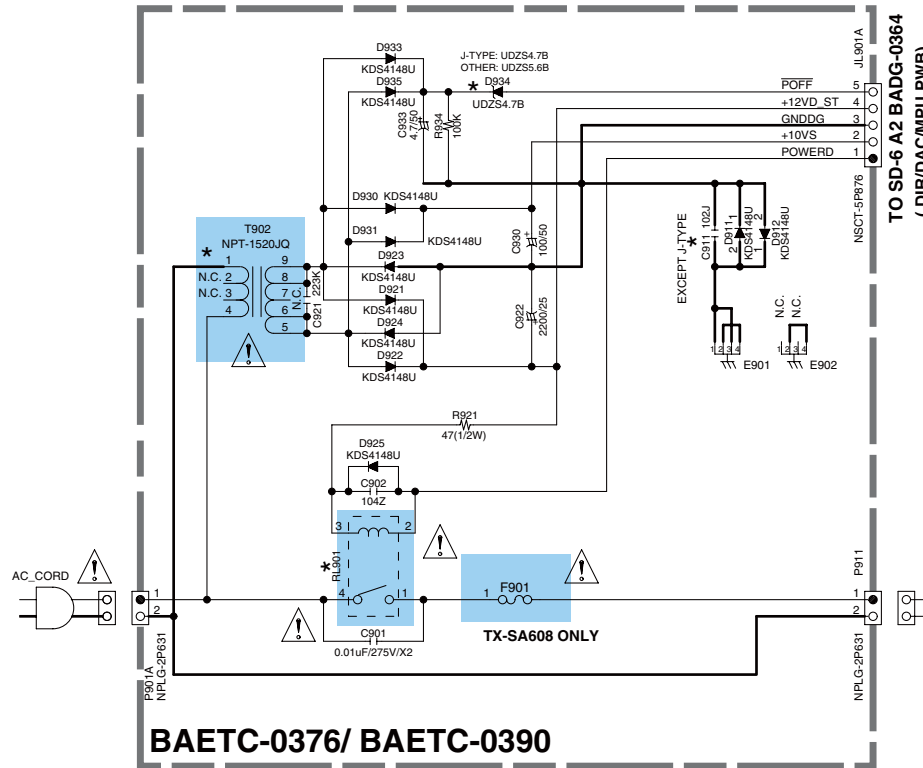

<T902>

TYPE	TX-SR308/HT-R380 TX-SR508/HT-R580 TX-SR578/TX-SR608 DTR-30.2	HT-R280/HT-R680 HT-R980/HT-RC230 HT-RC260/DTR20.2	HT-R538	TXSA578 TX-SA608
DC/ DD/ DF	NPT-1520JQ	NPT-1520JQ	---	---
MO/ MQ/ MR/ PA/ PP/ PB	NPT-1520GQ	---	NPT-1520GQ	---
JJ	---	---	---	NPT-1520JQ

<F901>

DC/ DD/ DF	8A 125V	8A 125V	---	---
MO/ MQ/ MR/ PA/ PP/ PB	T4A L250V	---	T4A L250V	---
JJ	---	---	---	10A 125V

<RL901>

DC/ DD/ DF	NRL-1P5A	NRL-1P5A	---	---
MO/ MQ/ MR/ PA/ PP/ PB	NRL-1P5A	---	NRL-1P5A	---
JJ	---	---	---	NRL-1P10A

<T901>

TYPE	DD/ DC/ DF	PA/ PP/ PB	MO/ MQ/ MR	JJ
TX-SR308 HT-R280 HT-R380 HT-R538 HT-RC230	NPT-1589D	NPT-1589P	NPT-1589M	---
TX-SR508 TX-SR578 TX-SA578 HT-R580 HT-R680 HT-R980	NPT-1594D	NPT-1594P	NPT-1594M	NPT-1594J
TX-SR608 HT-RC260 DTR-20.2 DTR-30.2	NPT-1592D	NPT-1592M	NPT-1592M	NPT-1592J

1

2

3

4

SCHEMATIC DIAGRAMS-15a

HDMI Section

1  
2  
3  
4  
5  
6  
7  
8

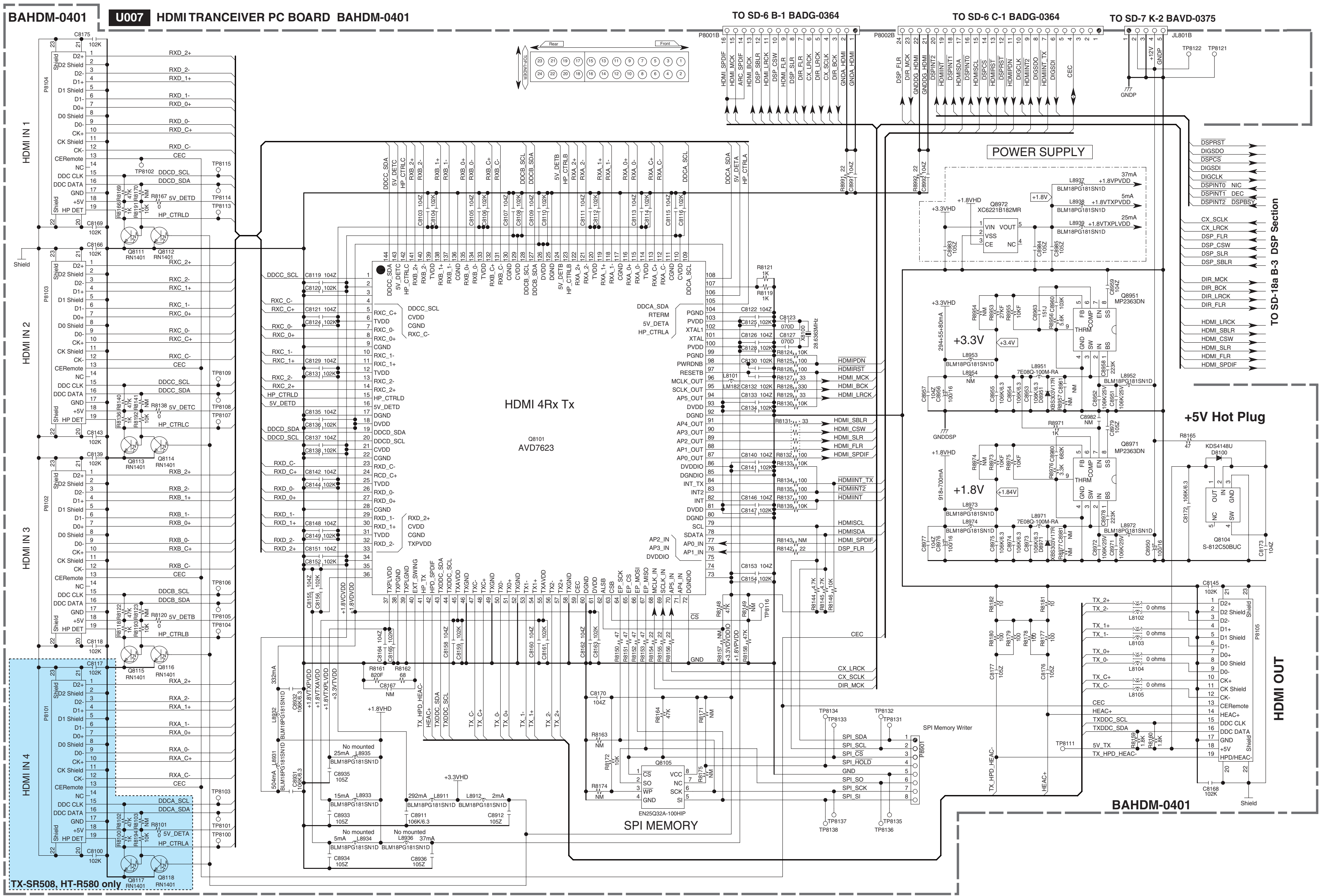

SCHEMATIC DIAGRAMS-18a

DSP Section

U007 HDMI DSP (DA788) PC BOARD BAHDM-0401

BAHDM-0401

TO SD-14 J-3 BAHDM-0401 (HDMI Section)

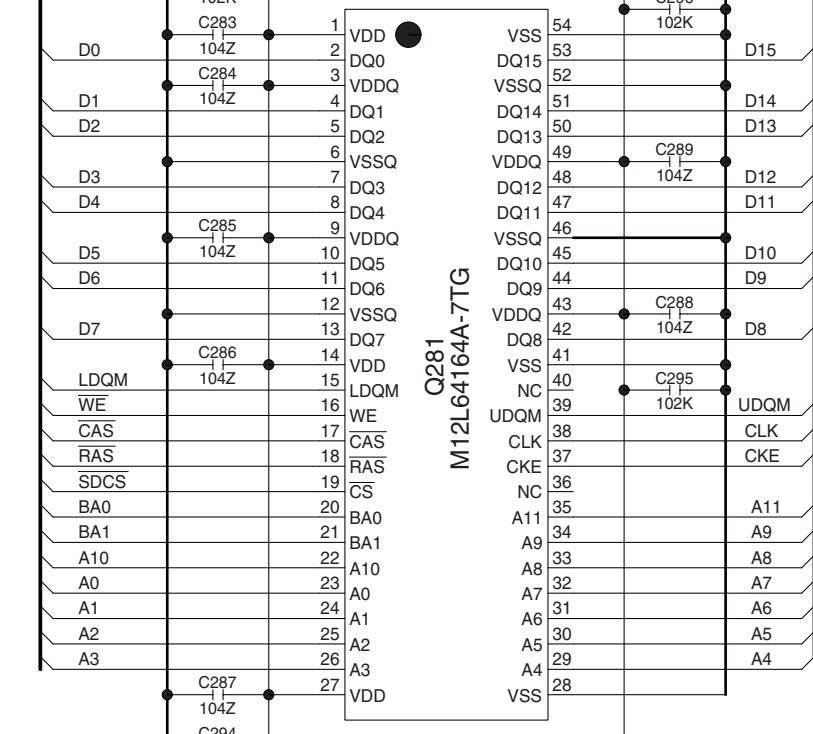
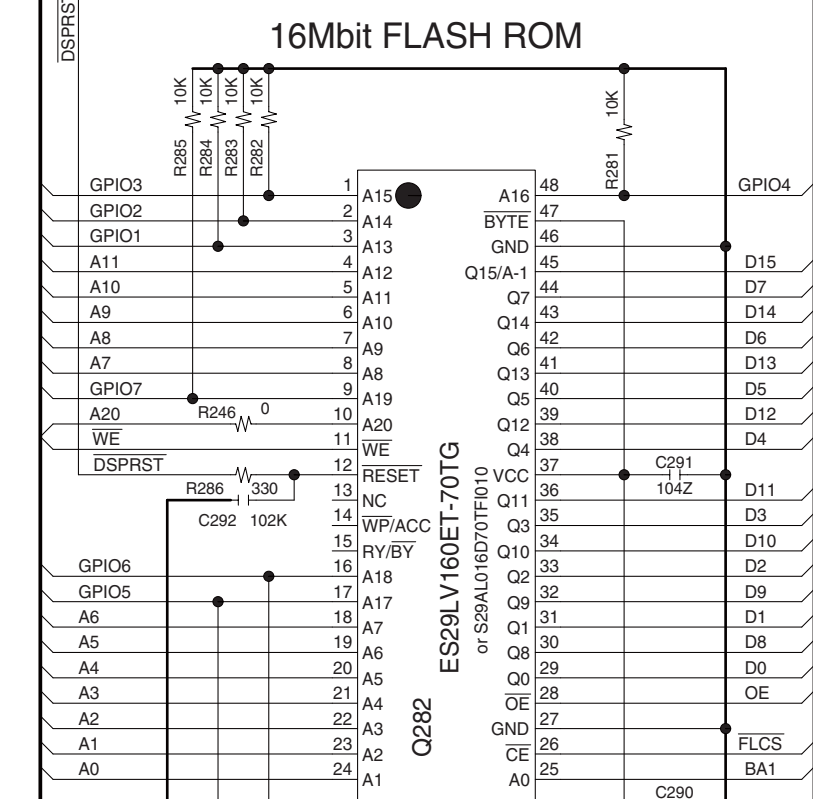
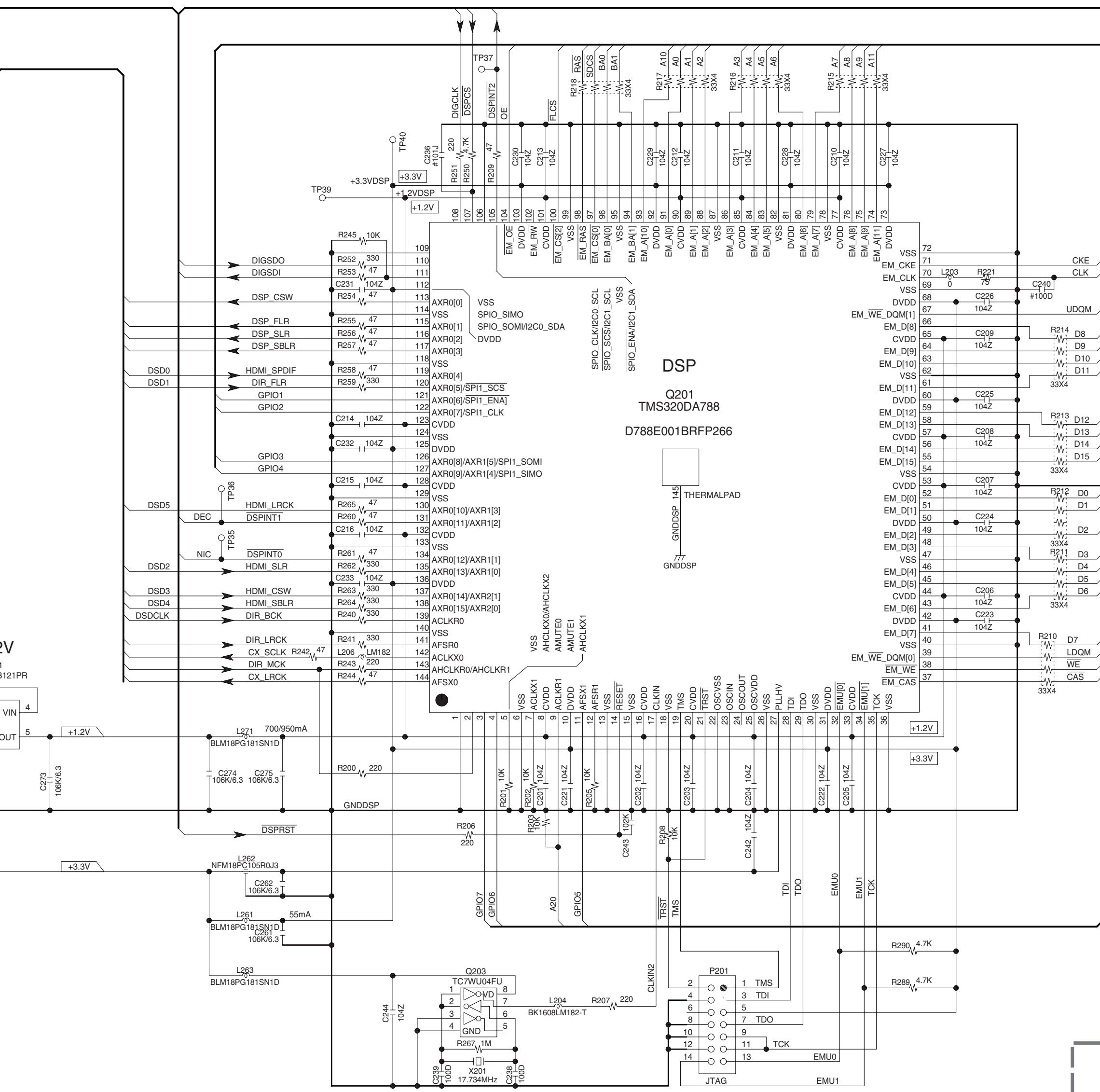
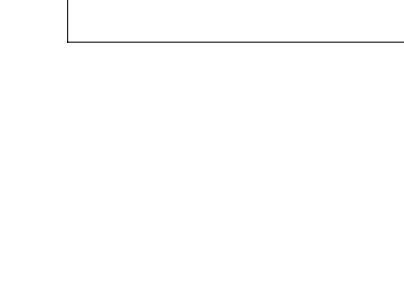
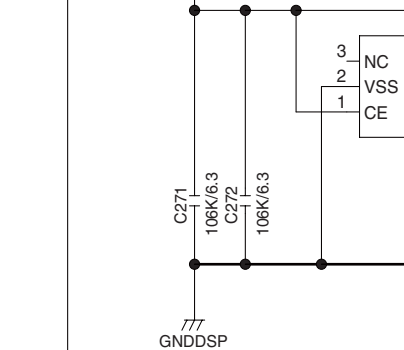
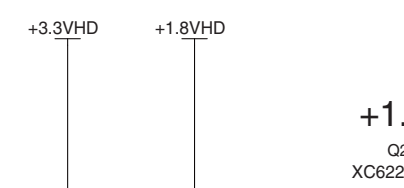
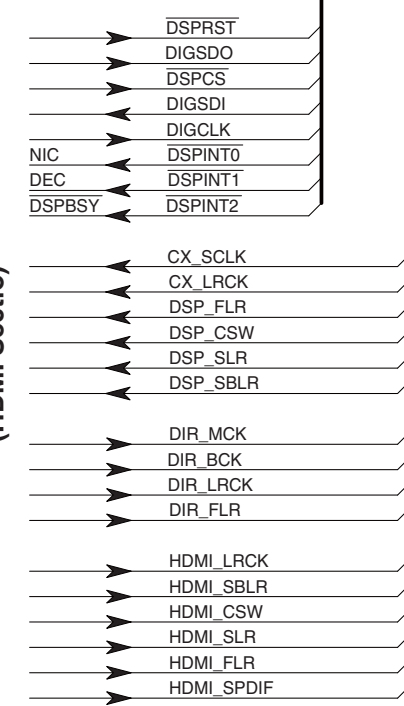

BAHDM-0401

PRINTED CIRCUIT BOARD VIEWS-1\_1  
AMPLIFIER SECTION

1  
2  
3  
4  
5

**U0010**

BAAF-0341 (AMPLIFIER PC BOARD)  
A-side(Component side)

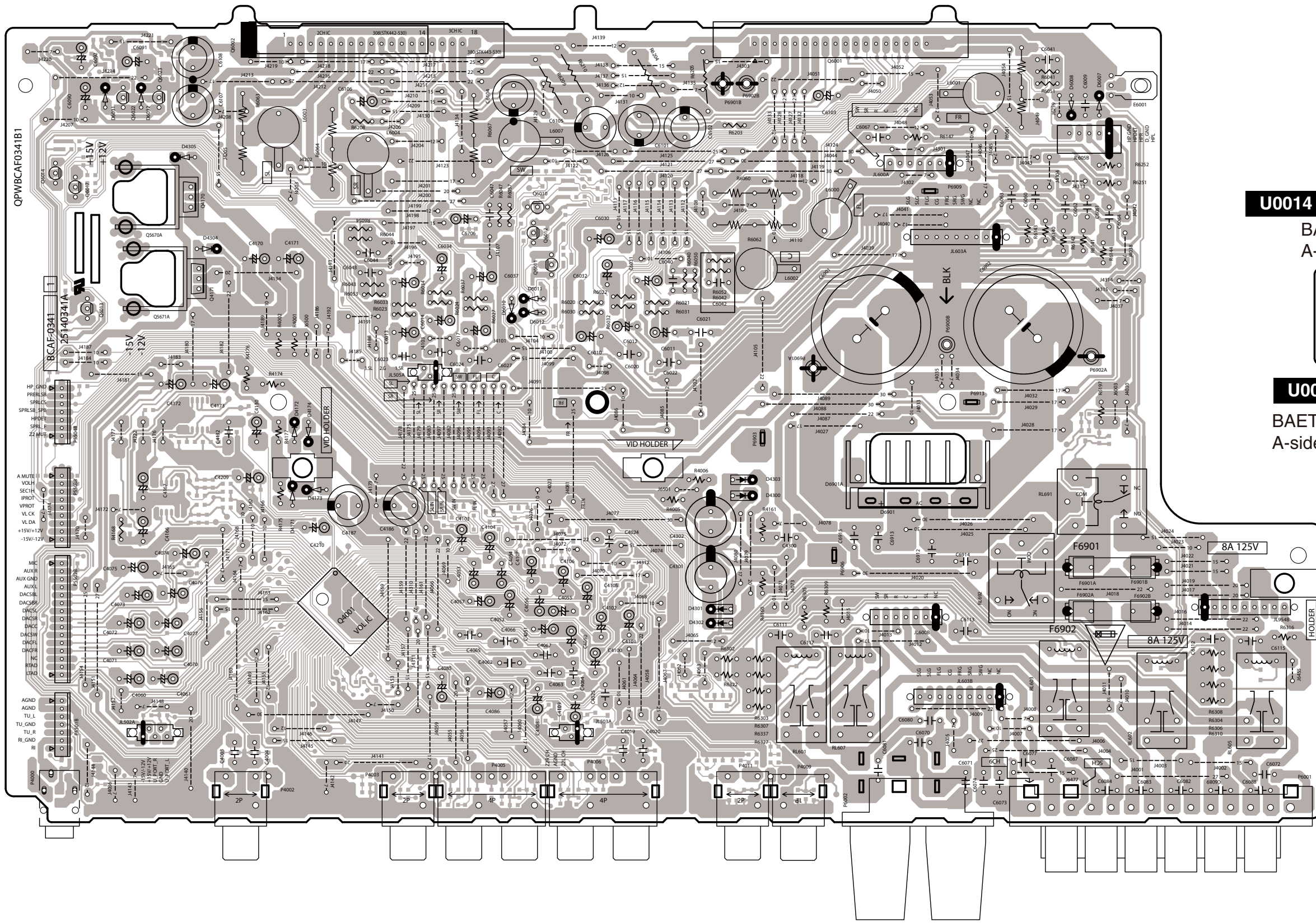

**U0011**

BAPS-0342 (FL TUBE -VP PC BOARD)  
A-side(Component side)

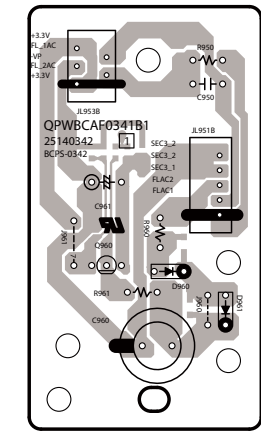

**U0014**

BAETC-0345 (TRANS TRM PC BOARD)  
A-side(Component side)

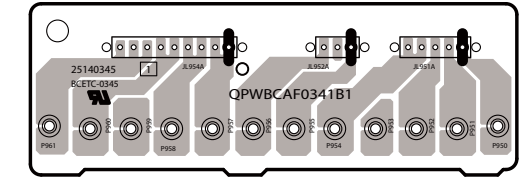

**U0012**

BAETC-0343 (THERMAL SEN PC BOARD)  
A-side(Component side)

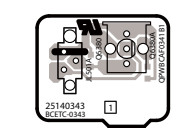



**PRINTED CIRCUIT BOARD VIEWS-1\_2  
AMPLIFIER SECTION**

1

**U0011**

BAPS-0342 (FL TUBE -VP PC BOARD)  
B-side(Soldering side)

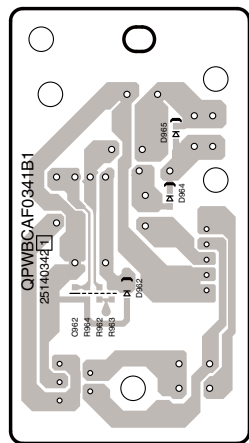

2

**U0010**

BAAF-0341 (AMPLIFIER PC BOARD)  
B-side(Soldering side)

3

**U0014**

BAETC-0345 (TRANS TRM PC BOARD)  
B-side(Soldering side)

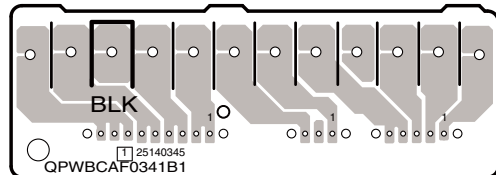

4

**U0012**

BAETC-0343 (THERMAL SEN PC BOARD)  
B-side(Soldering side)

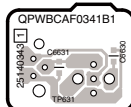

5

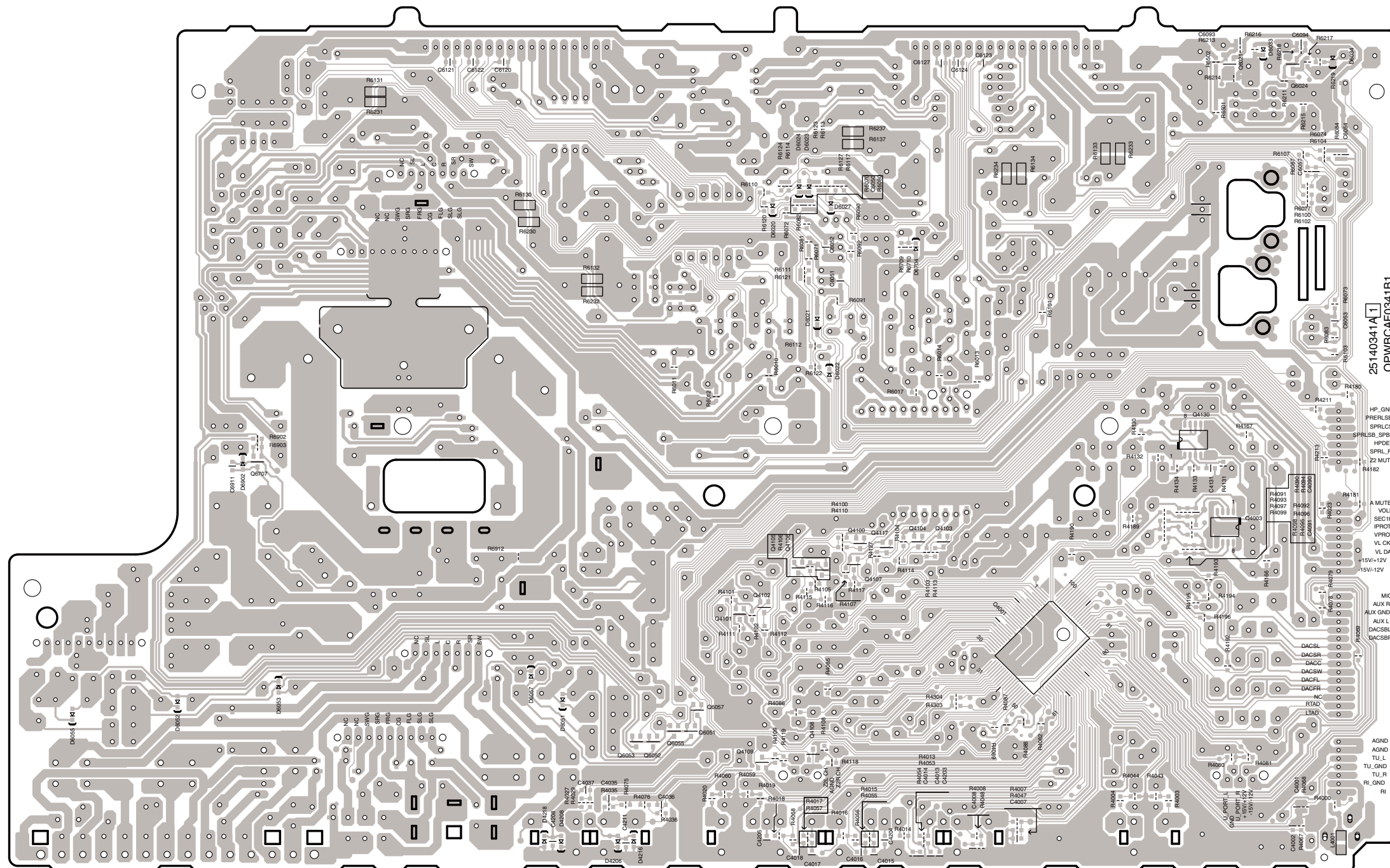

**PRINTED CIRCUIT BOARD VIEWS-3  
DAC/ MPU SECTION**

A B C D E F G H

1

**U0031**  
BAETC-0365 (U-PORT PC BOARD)  
A-side(Component side)

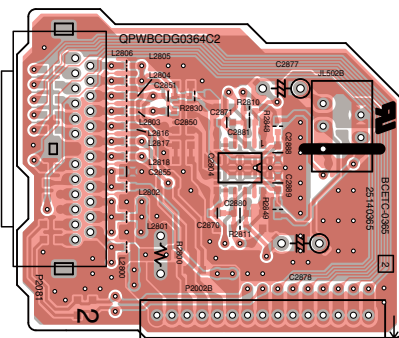

**U0031**  
BAETC-0365 (U-PORT PC BOARD)  
B-side(Soldering side)

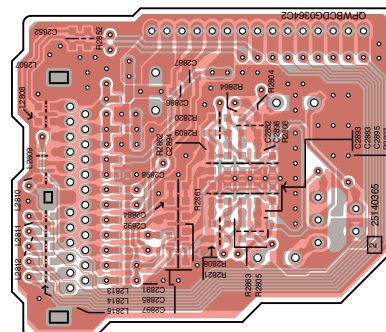

**U0030** BADG-0364 (MPU/DAC PC BOARD)  
A-side(Component side)

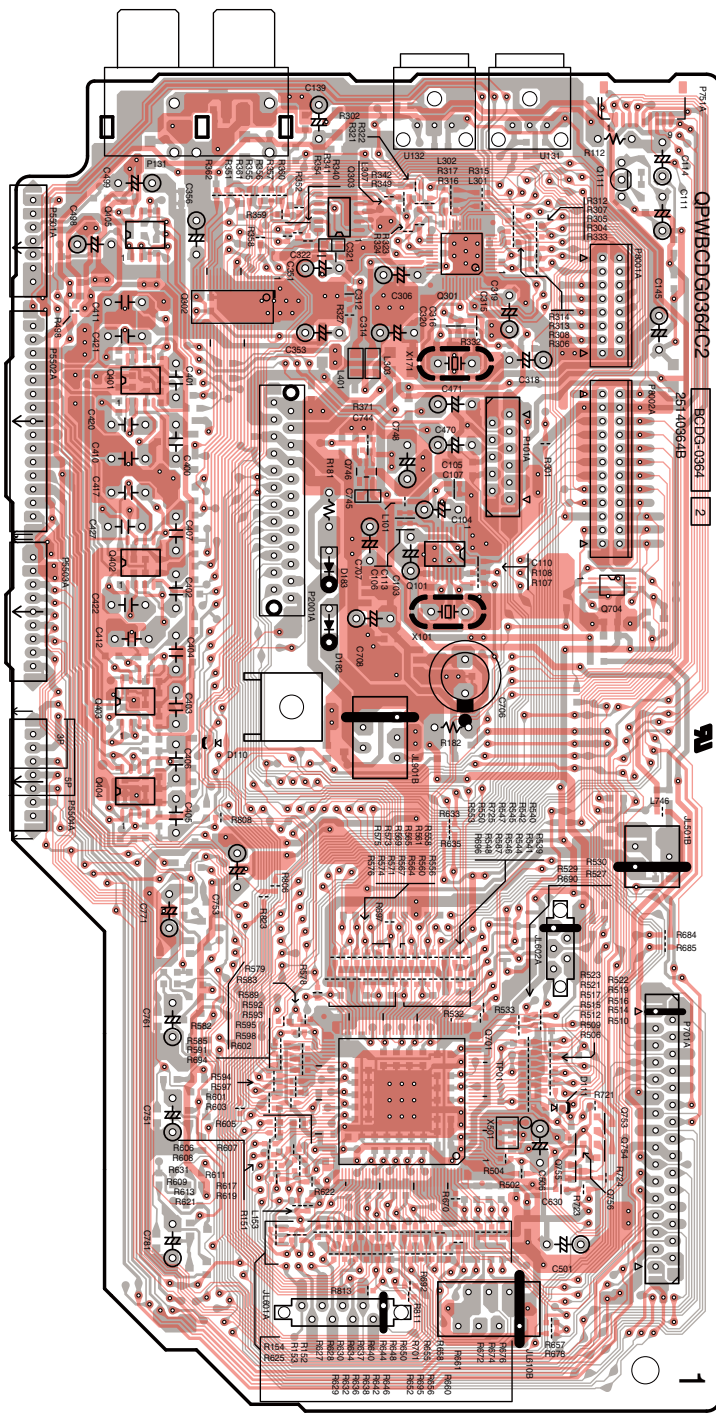

**U0030** BADG-0364 (MPU/DAC PC BOARD)  
B-side(Soldering side)

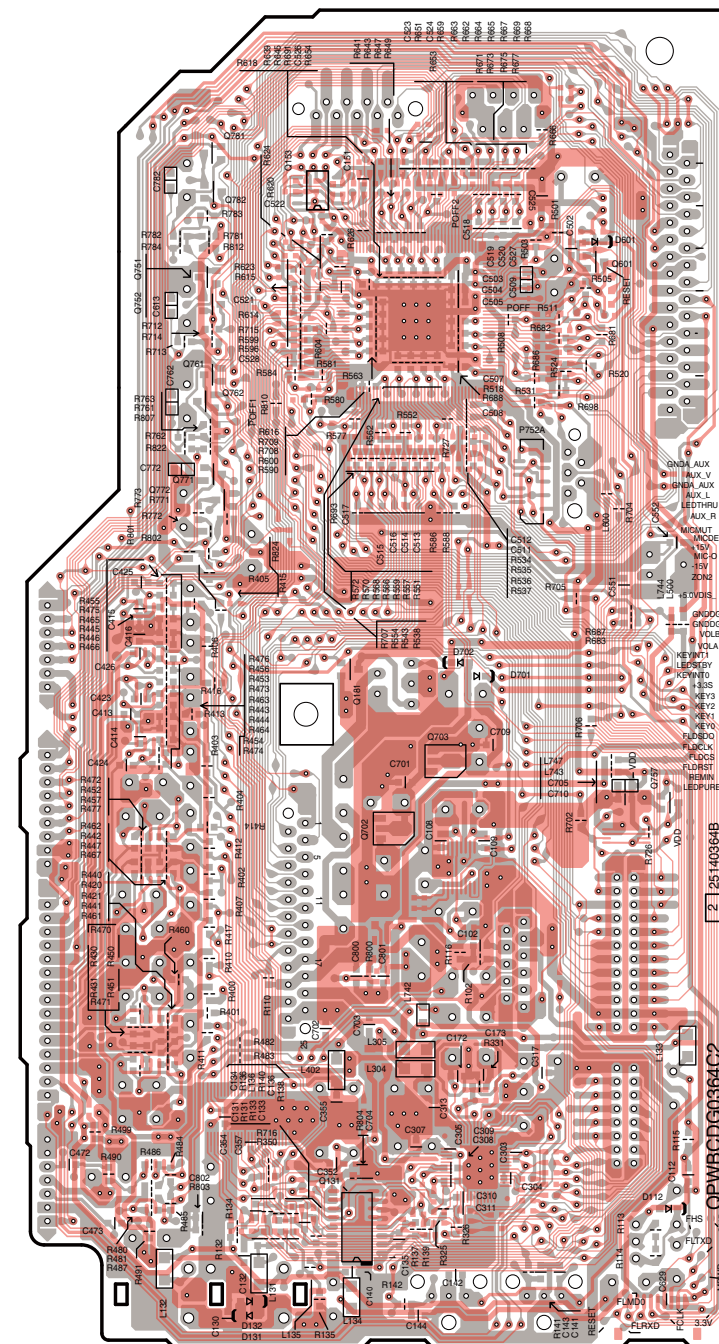

2

**U0032** Japanese Model Only  
BAETC-0366 (VLSC PC BOARD)  
A-side(Component side)

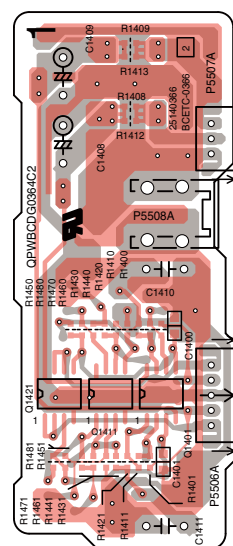

**U0032** Japanese Model Only  
BAETC-0366 (VLSC PC BOARD)  
B-side(Soldering side)

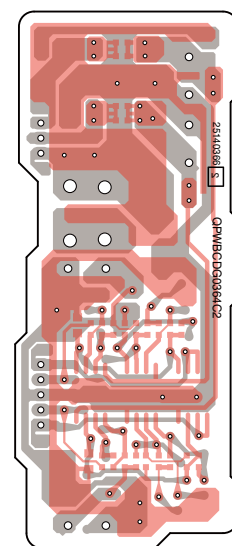

3

4

5

A B C D E F G H

**PRINTED CIRCUIT BOARD VIEW-4\_1  
DISPLAY SECTION**

**BADIS-0373 (DISPLAY PC BOARD)  
A-side(Component side)**

**U0040**

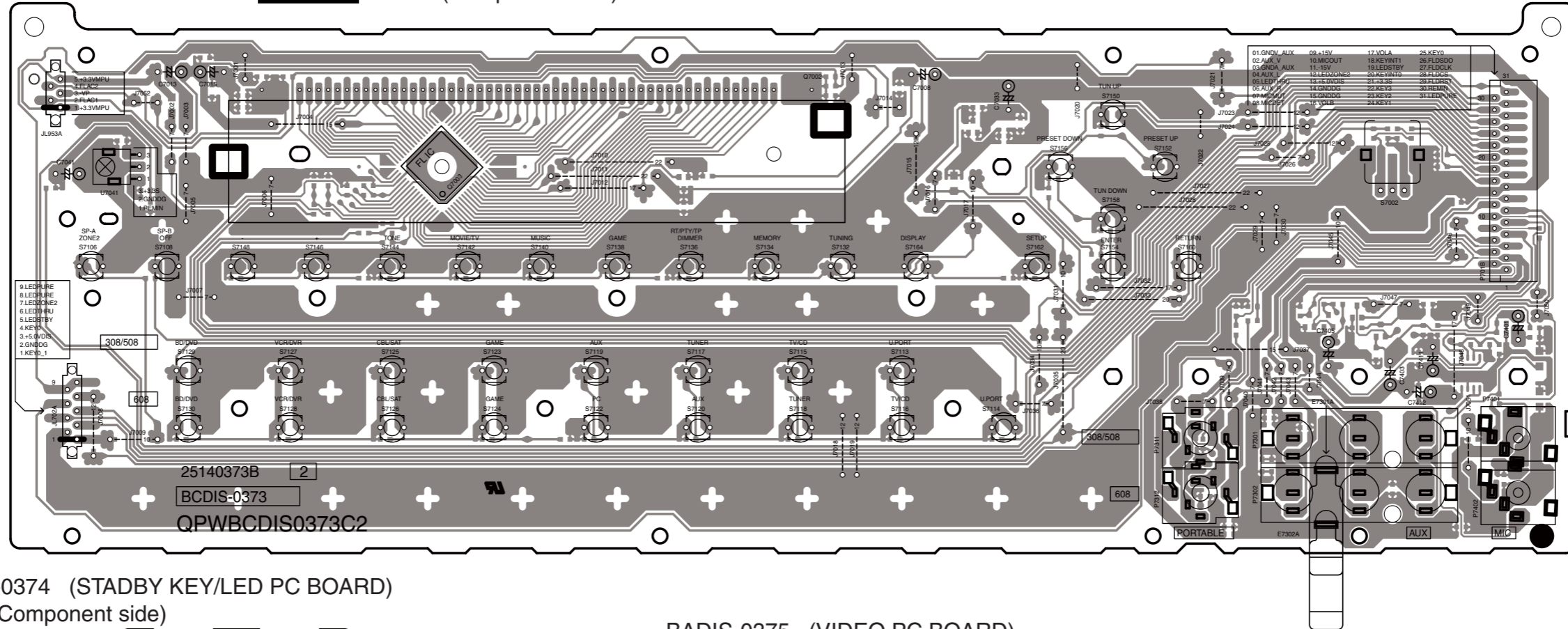

**BADIS-0374 (STADBY KEY/LED PC BOARD)  
A-side(Component side)**

**U0041**

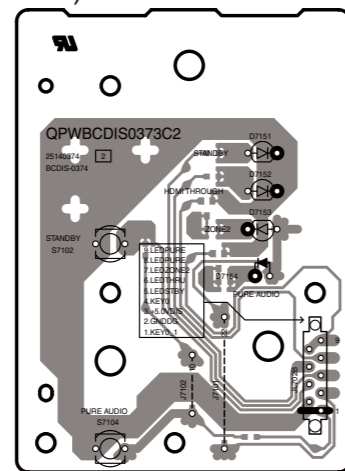

**BADIS-0375 (VIDEO PC BOARD)  
A-side(Component side)**

**U0042**

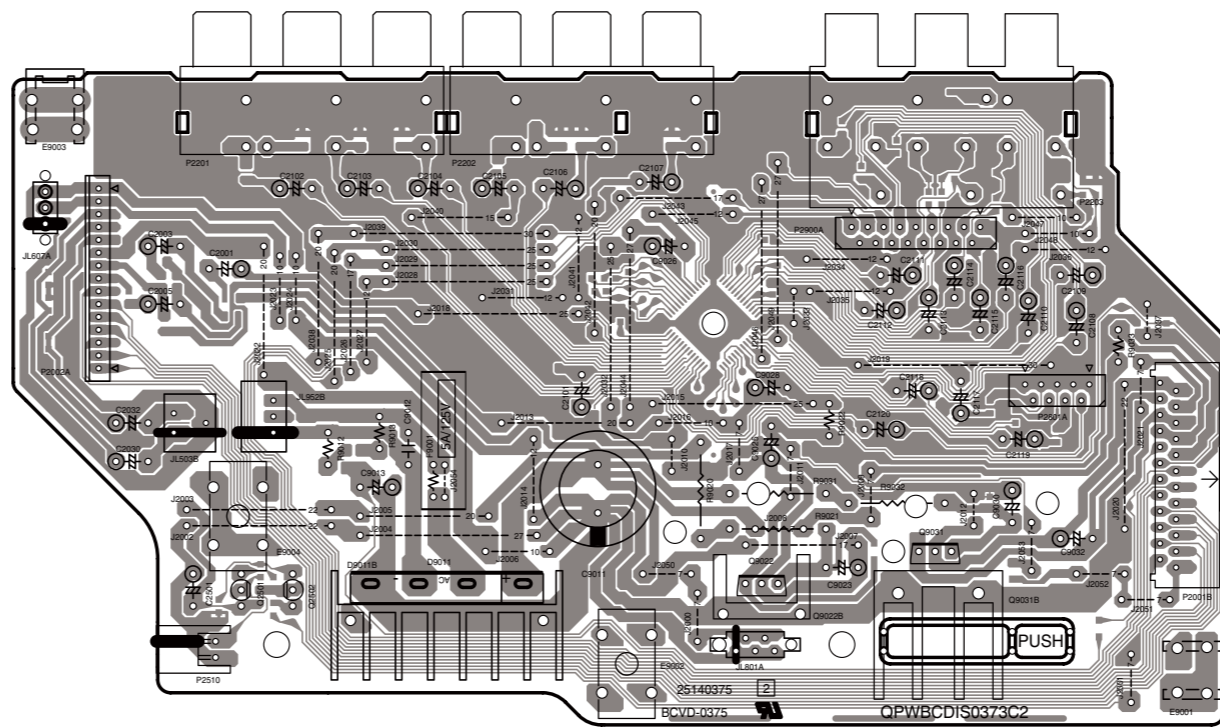

**U0043**

**BAETC-0376 (POW SUPPLY PC BOARD)  
A-side(Component side)**

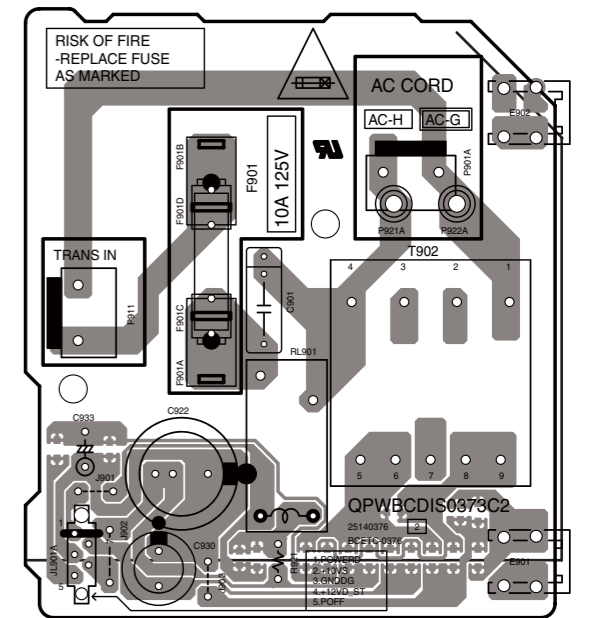

**BAETC-0377 (HP JACK PC BOARD)  
A-side(Component side)**

**U0044**

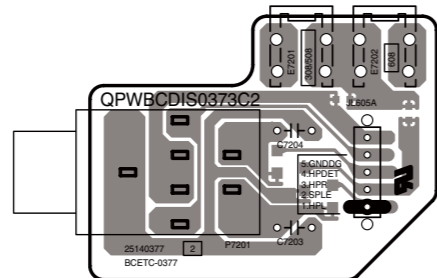

A B C D E F G H

**PRINTED CIRCUIT BOARD VIEWS-4\_2**  
**DISPLAY SECTION**

**U0040** BADIS-0373 (DISPLAY PC BOARD)  
B-side(Soldering side)

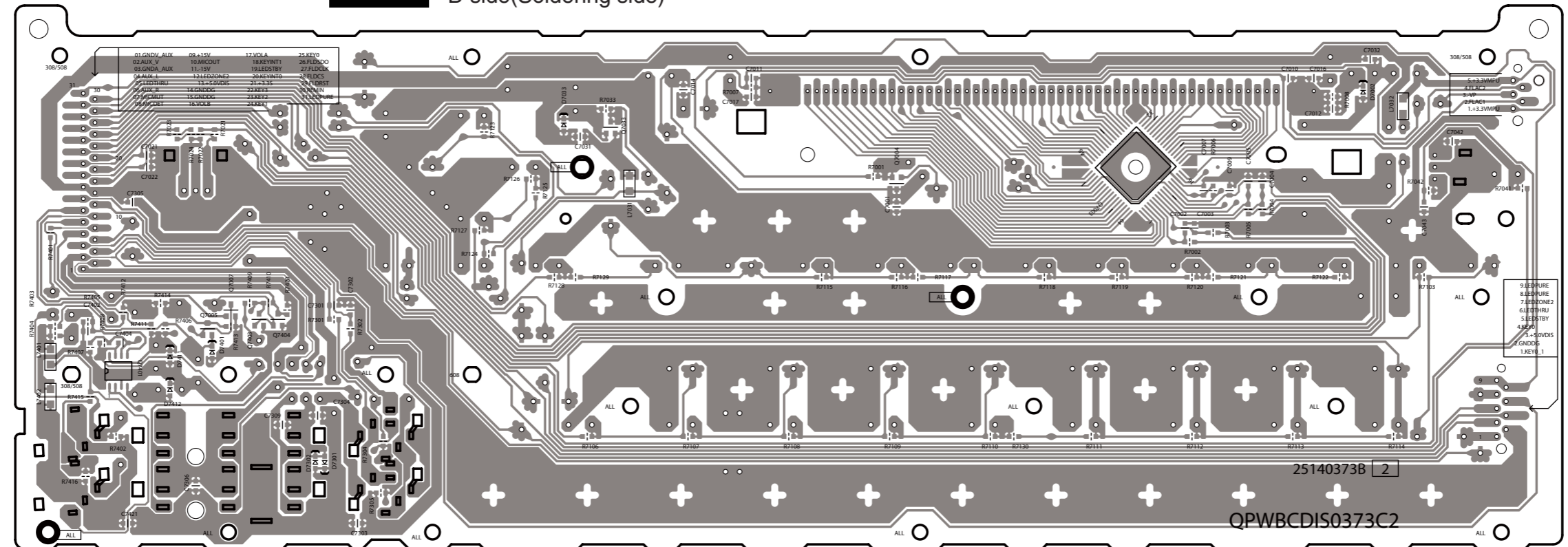

**U0042** BADIS-0375 (VIDEO PC BOARD)  
B-side(Soldering side)

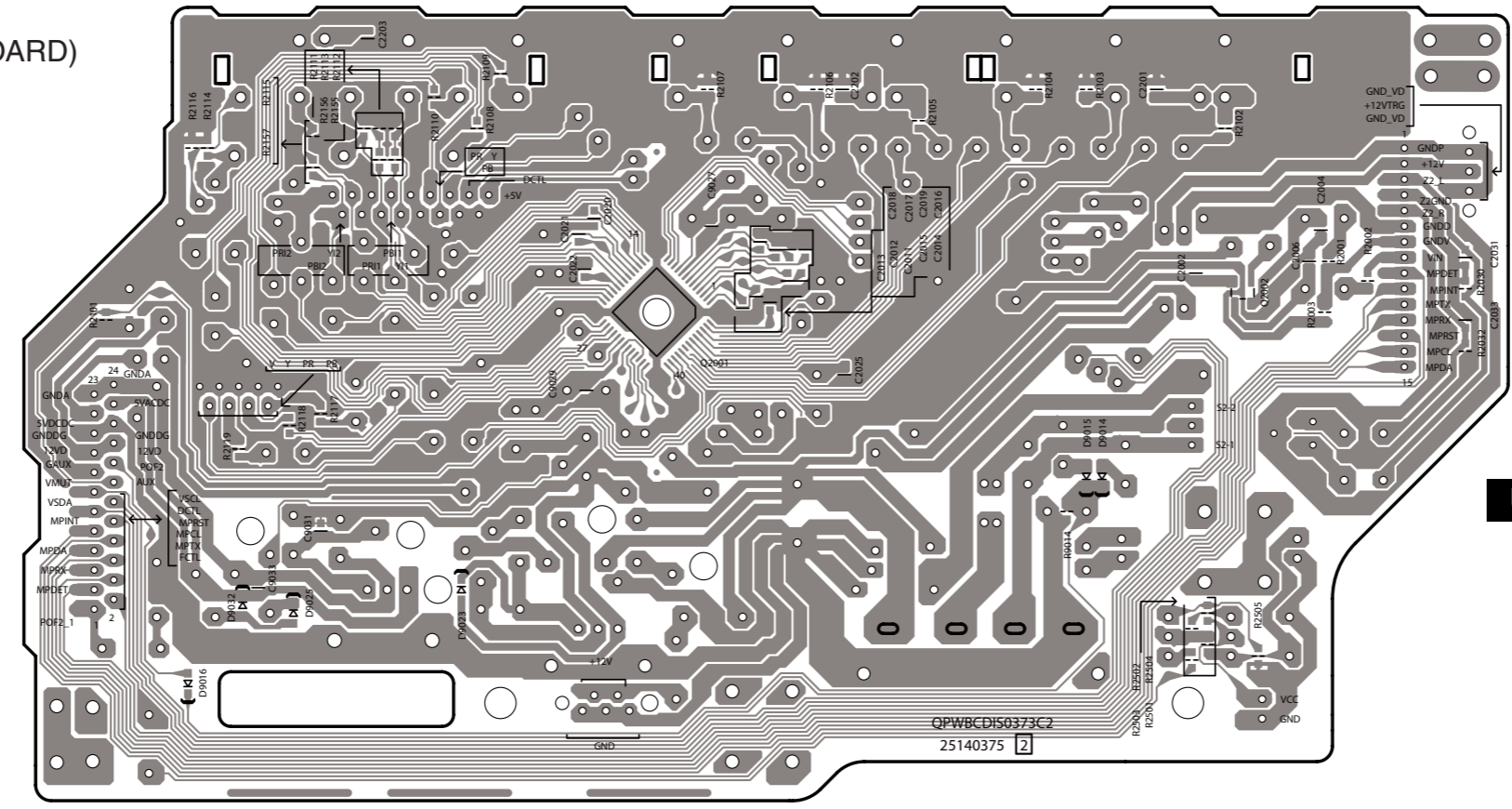

**U0041** BADIS-0376 (STADBY KEY/LED PC BOARD)  
B-side(Soldering side)

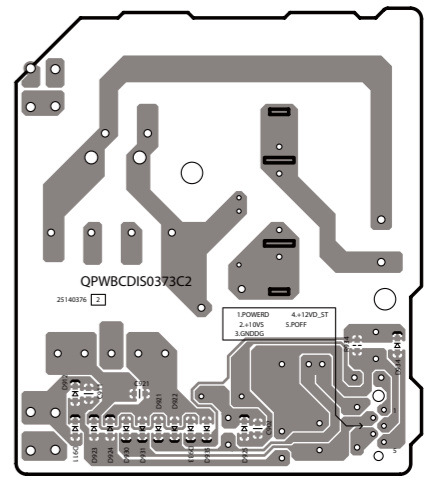

**U0044** BAETC-0377 (HP JACK PC BOARD)  
B-side(Soldering side)

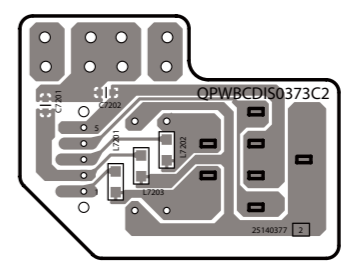

**U0043** BAETC-0374 (POW SUPPLY PC BOARD)  
B-side(Soldering side)

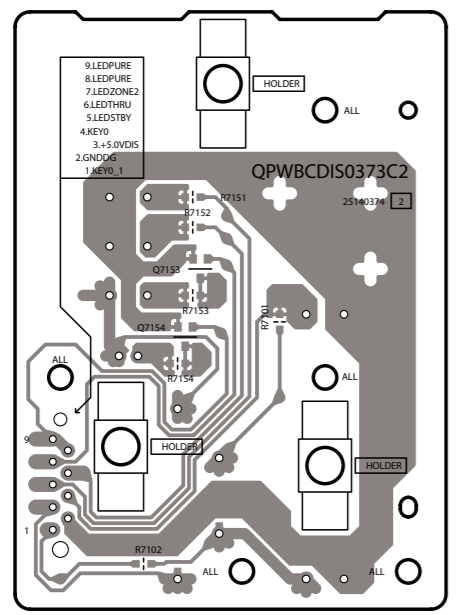

1

2

3

4

5

A B C D E F G H

PRINTED CIRCUIT BOARD VIEWS-7  
HDMI SECTION

1

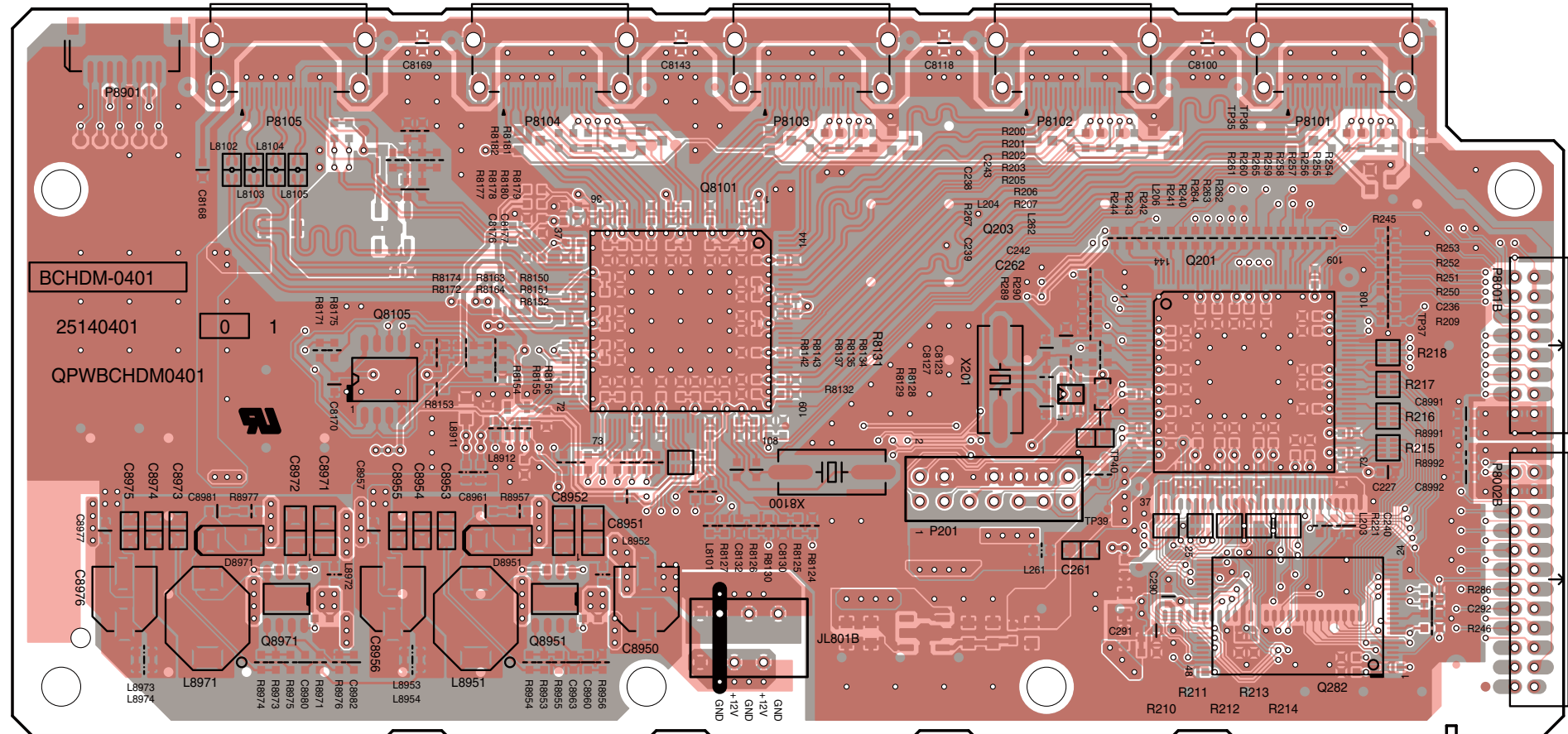

**U0070**

BAHDM-0401 (HDMI PC BOARD)  
A-side(Component side)

2

3

4

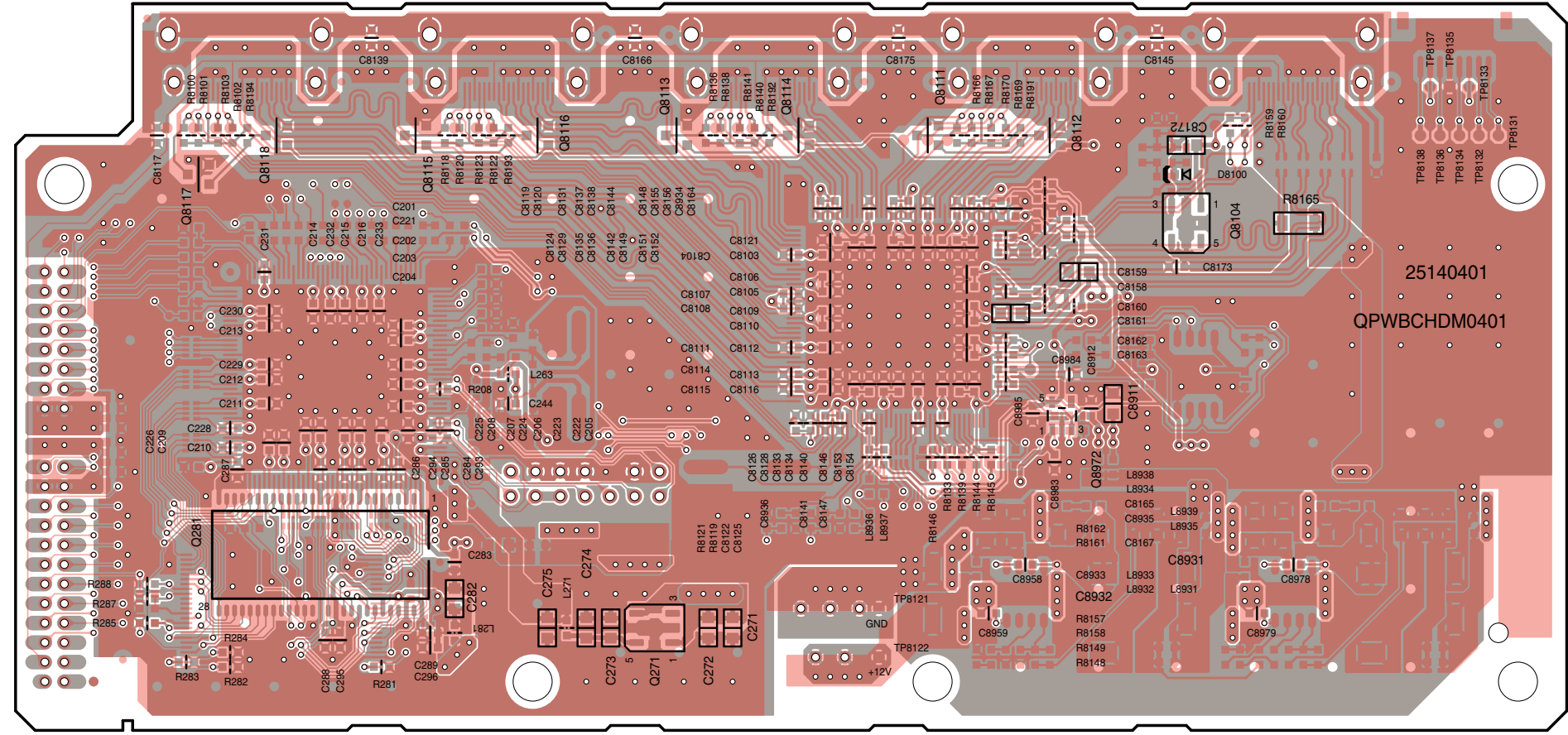

**U0070**

BAHDM-0401 (HDMI PC BOARD)  
B-side(Soldering side)

5

**HT-R280**

**<Note>**

Parts marked by "NSP" are generally unavailable because they are not in our Master Spare Parts List.

**<Notes>**

**<B>** : Black model

**NOTE : THE COMPONENTS IDENTIFIED BY THE MARK ! ARE CRITICAL FOR RISK OF FIRE AND ELECTRIC SHOCK. REPLACE ONLY WITH PART NUMBER SPECIFIED.**

HT-R280 in HTiB "AVX-280"

**<MDC>** : 120V,Canadian model

**HT-R280**

**EXPLODED VIEW PARTS LIST**

REF. NO.	PART NAME	DESCRIPTION	Q'TY	PART NO. (SN)	REMARKS
<b>[CHASSIS SCREW]</b>					
A001	CHASSIS	TX-SR307	1		NSP <B>
A003	BOTTOM LEG	---	4	27175432C	<B>
A005	CUSHION	---	4		NSP <B>
A007	SCREW	3TTB+8B(3CM)SR	4		NSP <B>
A009	HOLDER	KGLS-8RT	3		NSP <B>
A010	HOLDER	KGPS-8RF	1		NSP <B>
A011	HOLDER	KGLS-10RT	1		NSP <B>
A013	HOLDER	KGPS-14RF	2		NSP <B>
A015	HOLDER	KGPS-14RF	1		NSP <B>
A019	HOLDER	KGPS-16RF	1		NSP <B>
A021	HOLDER	KGLS-22S	2		NSP <B>
A025	SCREW	4TTC+8C(3BC)	4		NSP <B>
A030	HEAT SINK	307P-2	1		NSP <B>
A032	RETAINER	(HL)	1		NSP <B>
A034	RETAINER	(HR)	1		NSP <B>
A036	SCREW	3TTB+8B(3CM)SR	5		NSP <B>
A038	SCREW	3TTB+8B(3CM)SR	2		NSP <B>
A040	SCREW	3TTB+8B(3CM)SR	4		NSP <B>
A041	CLIP	CS-1U	1		NSP <B>
A042	SCREW	3TTB+8B(3CM)SR	2		NSP <B>
A044	HOLDER	KGLS-8RT	1		NSP <B>
A050	SCREW	3SMS8VSW+18B3CM	4		NSP <B>
A054	SCREW	3TTB+8B(3CM)SR	1		NSP <B>
A056	BUSHING	S-RELIEF #2271	1		NSP <B>
A060	WIRE TIE	BINDER(CLAMPER)UL	2		NSP <B>
A069	SCREW	3TTB+8B(3BC)	1		NSP <B>
A070	LABEL	(SP)307	1	29390688A	<B CMDC>
A101	REAR PANEL	HT-R280DC	1	27124207	N <B CMDC>
A102	CUSHION	---	2		NSP <B>
A103	SCREW	3P+6FN(3BC)	4		NSP <B CMDC>
A105	SCREW	3TTB+8B(3BC)	24		NSP <B CMDC>
A109	SCREW	3P+6FN(3BC)	2		NSP <B CMDC>
<b>[CABINET]</b>					
A201	F PANEL	HT-R280(B)DC	1	27213412	N <B CMDC>
A202	CLEAR PLT	(AS)308D	1	28192281	<B CMDC>
A207	BADGE	BADGE	1	28135244	<B>
A213	KNOB	(INP)	1	28326666	<B>
A215	KNOB	(SEL)	1	28326665	<B>

A217	KNOB	(STNBY)	1	28326663A		<B>
A219	KNOB	(CUR)	1	28326664A		<B>
A221	IB CUSHION	W15*3t TAPE	1		NSP	<B>
A225	SCREW	2.6TTB+8B(3BC)	23		NSP	<B>
A230	RETAINER	(U)	1		NSP	<B>
A232	SCREW	2.6TTB+8B(3BC)	5		NSP	<B>
A234	RETAINER	(L)	1		NSP	<B>
A236	RETAINER	(R)	1		NSP	<B>
A238	SCREW	2.6TTB+8B(3BC)	4		NSP	<B>
A250	B PLATE	--	1		NSP	<B>
A254	WIRE TIE	BSK-1	5		NSP	<B>
A256	SCREW	3TTB+8B(3CM)SR	1		NSP	<B>
A258	SCREW	3TTB+8B(3CM)SR	4		NSP	<B>
A260	SCREW	3TTB+8B(3BC)	3		NSP	<B>
A261	TAPE	TAPE(CLOTH-16U)	1		NSP	<B>
A262	TAPE	TAPE(CLOTH-16U)	1		NSP	<B>
A263	TAPE	TAPE(CLOTH-16U)	1		NSP	<B>
A264	CUSHION	--	2		NSP	<B>
A273	HOLDER	KGLS-4S	3		NSP	<B>
A321	KNOB	(VOL) BLACK	1	28326514		<B>
A340	COVER	(B) (Bent)	1	28210031		<B>
A340	COVER	(B) (Not Bent)	1	28210031Z		<B>
A342	SCREW	3TTB+8B(3BC)	7		NSP	<B>
A360	LABEL	(COVER)	1		NSP	<B>
A362	LABEL	HOOKUP-ONKYO	1		NSP	<B CMDC>
<b>[TRANS COIL]</b>						
T901	P TRANS	NPT-1589D	1	2301970	!	<B CMDC>
<b>[SW TRM]</b>						
F6901	FUSE	8A-T/UL-ST2	1	252261GR	!	<B>
F6902	FUSE	8A-T/UL-ST2	1	252261GR	!	<B>
F901	FUSE	8A-UL/T-233	1	252329GR	!	<B CMDC>
F901or	FUSE	8A-T/UL-ST2	(1)	252261GR	!	<B CMDC>
P101	FFC	NCFC7-111512	1	2047111512		<B>
P701	FFC	NCFC7-312012	1	2047312012		<B>
P901	AC CORD	AS-UC-2	1	253368AYUN	!	<B CMDC>
P901or	AC CORD	AS-UC-2	(1)	253368BLTK	!	<B CMDC>
<b>[TUNER UNIT]</b>						
U001	AF-AS(Amplifier Assy)	BAAF-0341-1D *	1	1B247541-1D		or 380c
U0010	AF-AS(Amplifier Assy)	BAAF-0341-1D	1	1B2475341-1D		
U0011	PWB (FL TUB -VP)	BAAPS-0342-1D	1	1B2475342-1D	N	
U0012	PWB(Thermal Sensor)	BAETC-0343-1D	1	1B2475343-1D	N	
U0013	PWB(Thermal Sensor FIX)	BAETC-0344-1D	1	1B2475344-1D	N NSP	
U0014	PWB(Trans Terminal )	BAETC-0345-1D	1	1B2475345-1D	N	
U0015	PWB(FFC FIX)	BAETC-0346-1D	1	1B2475346-1D	N NSP	
U003	DG-AS(MPU/DAC/DIR Assy)	BADG-0364-1K *	1	1B247564-1K		280c
U0030	DG-AS(MPU/DAC/DIR Assy)	BADG-0364-1K	1	1B2475364-1K		
U0031	PWB(U-PORT)	BADG-0365-1K	1	1B2475365-1K	N	
U004	DIS-AS(Display Assy)	BADIS-0373-1C *	1	1B247573-1C		or 380c
U0040	DIS-AS(Display Assy)	BADIS-0373-1C	1	1B2475373-1C		
U0041	PWB(STANDBY key/LED)	BADIS-0374-1C	1	Included in "REF.NO. U0040"	N	
U0042	PWB(Video Assy)	BAVD-0375-1C	1	1B2475375-1C	N	
U0043	PWB(Power Supply)	BAETC-0376-1C	1	1B2475376-1C	N	
U0044	PWB(HP-Jack)	BAETC-0377-1C	1	1B2475377-1C	N	

U007	HDM-AS(HDMI Assy)	BAHDM-0401-1A *	1	1B247501-1A	or 308c
U010	TUNER UNIT	FAEH06-A01US	1	240166	<B CMDC>

### HT-R280

## PACKING PROCEDURES PARTS LIST

REF. NO	PART NAME	DESCRIPTION	Q'TY	PART NO. (SN)	REMARKS
<b>[PACKING]</b>					
A601	PAD	{(AS)370	1	29092455A	<B CMDC>
A605	POLY BAG	w850xd650	1	291100245	<B>
A606	TAPE	{(SEROHAN)NITTO NO.29	1	29110149	<B>
A608	SHEET	---	1	29095906	<B CMDC>
A611	TAPE	{(SEROHAN)NITTO NO.29	1	29110149	<B>
A704A	LABEL	{(DES)280BMDC	{1}	29391351	N <B CMDC>
<b>[ACCESSARY]</b>					
A672	POLY BAG	w250xd350	1	291100250A	<B CMDC>
A674	POLY BAG	D250xd300xW300(t0.04)	1	291100256A	<B>
A676	TAPE	{(SEROHAN)NITTO NO.29	1	29110149	<B>
A801	INS MANUAL	En(HT-R280)	1	29400475	N <B CMDC>
A802	INS MANUAL	Es(HT-R280)	1	29400476	N <B CMDC>
A810	INS MANUAL	En(QSS AVX-280)	1	29400477	N <B CMDC>
A826	INST SHEET	U11(2010_RIHD)	1	29355782	<B>
A835	HANDBILL	{(UP-A1)US	1	29380155	<B CMDC>
A855	REMO CON	RC-762M	1	24140762	<B>
A858	ANT COIL	NMA-3057	1	232140	<B>
A859	FM ANT AS	Type W	1	292191	<B>
A861	BATTERY	R6/AA(UM-3)	2	3010194	<B CMDC>
A861or	BATTERY	R6/AA(UM-3)	{2}	3010054	<B CMDC>
A885	WRNTY CARD	{(ONKYO)	1	29365135	<B CMDC>

### HT-R280

## PC BOARD PARTS LIST

U001	AF-AS(Amplifier Assy) U0010+U0011+U0012+U0013+U0014+U0015)	BAAF-0341-1D *	1	1B247541-1D	or 380c
U0010	AF-AS(Amplifier Assy)	BAAF-0341-1D	1	1B2475341-1D	
U0011	PWB (FL TUB -VP)	BAPS-0342-1D	1	1B2475342-1D	N
U0012	PWB(Thermal Sensor)	BAETC-0343-1D	1	1B2475343-1D	N
U0013	PWB(Thermal Sensor FIX)	BAETC-0344-1D	1	1B2475344-1D	N
U0014	PWB(Trans Terminal)	BAETC-0345-1D	1	1B2475345-1D	N
U0015	PWB(FFC FIX)	BAETC-0346-1D	1	1B2475346-1D	N

CIRCUIT	PART NAME	DESCRIPTION	Q'TY	PART NO. (SN)	REMARKS
<b>[SEMI CONDUCTOR]</b>					
D4171	ZENER D	MTZJ6.2B	1	224470622T	
D4172	ZENER D	MTZJ6.2B	1	224470622T	
D4173	DIODE	1SS133	1	223163T	
D4174	DIODE	1SS133	1	223163T	
D4300	DIODE	RL1N4003	1	22380260T	
D4300 or	DIODE	GP104003E	{1}	22380035T	
D4301	DIODE	RL1N4003	1	22380260T	



D4301 or	DIODE	GP104003E	(1)	22380035T		
D4302	DIODE	RL1N4003	1	22380260T		
D4302 or	DIODE	GP104003E	(1)	22380035T		
D4303	DIODE	RL1N4003	1	22380260T		
D4303 or	DIODE	GP104003E	(1)	22380035T		
D4304	DIODE	1SS133	1	223163T		
D4305	DIODE	1SS133	1	223163T		
D6020	C-DIODE	KDS4148U	1			NSP
D6020 or	C-DIODE	1SS352	(1)			NSP
D6020 or	C-DIODE	MA2J111	(1)			NSP
D6021	C-DIODE	KDS4148U	1			NSP
D6021 or	C-DIODE	1SS352	(1)			NSP
D6021 or	C-DIODE	MA2J111	(1)			NSP
D6022	C-DIODE	KDS4148U	1			NSP
D6022 or	C-DIODE	1SS352	(1)			NSP
D6022 or	C-DIODE	MA2J111	(1)			NSP
D6023	C-DIODE	KDS4148U	1			NSP
D6023 or	C-DIODE	1SS352	(1)			NSP
D6023 or	C-DIODE	MA2J111	(1)			NSP
D6024	C-DIODE	KDS4148U	1			NSP
D6024 or	C-DIODE	1SS352	(1)			NSP
D6024 or	C-DIODE	MA2J111	(1)			NSP
D6027	C-DIODE	KDS4148U	1			NSP <B CMDC>
D6027 or	C-DIODE	1SS352	(1)			NSP <B CMDC>
D6027 or	C-DIODE	MA2J111	(1)			NSP <B CMDC>
D6031	DIODE	1SS133	1	223163T		
D6032	DIODE	1SS133	1	223163T		
D6033	ZENER D	UDZS3.3B	1	224550330R2		
D6034	ZENER D	UDZS3.3B	1	224550330R2		
D6051	C-DIODE	KDS4148U	1			NSP
D6051 or	C-DIODE	1SS352	(1)			NSP
D6051 or	C-DIODE	MA2J111	(1)			NSP
D6052	C-DIODE	KDS4148U	1			NSP
D6052 or	C-DIODE	1SS352	(1)			NSP
D6052 or	C-DIODE	MA2J111	(1)			NSP
D6053	C-DIODE	KDS4148U	1			NSP
D6053 or	C-DIODE	1SS352	(1)			NSP
D6053 or	C-DIODE	MA2J111	(1)			NSP
D6055	C-DIODE	KDS4148U	1			NSP
D6055 or	C-DIODE	1SS352	(1)			NSP
D6055 or	C-DIODE	MA2J111	(1)			NSP
D6057	C-DIODE	KDS4148U	1			NSP <B CMDC>
D6057 or	C-DIODE	1SS352	(1)			NSP <B CMDC>

D6057 or	C-DIODE	MA2J111	(1)		NSP	<B CMDC>
D6704	ZENER D	UDZS3.3B	1	224550330R2		
D6901	DIODE	D5SBA20	1	22380130		
D6901A	HEAT SINK	RAD-083	1		NSP	
D6901C	SCREW	3P+10FN(3BC)	1		NSP	
D6902	C-DIODE	KDS4148U	1		NSP	
D6902 or	C-DIODE	1SS352	(1)		NSP	
D6902 or	C-DIODE	MA2J111	(1)		NSP	
D960	DIODE	RL1N4003	1	22380260T		
D961	DIODE	RL1N4003	1	22380260T		
D962	ZENER D	UDZS36B	1	224553600R2		
Q4001	IC	R2A15218FP	1	22242605R3		
Q4003	IC	NJM4580M-D	1	22241448R2		
Q4100	TR	RN1441	1	2215410R2		
Q4101	TR	RN1441	1	2215410R2		
Q4102	TR	RN1441	1	2215410R2		
Q4103	TR	RN1441	1	2215410R2		
Q4104	TR	RN1441	1	2215410R2		
Q4107	TR	RN1441	1	2215410R2		
Q4117	TR	RN1441	1	2215410R2		
Q4130	IC	NJM4580M-D	1	22241448R2		
Q4170	IC	78M12HF(NJM78M12FA)	1	222780125JRC		<B CMDC>
Q4170 or	IC	78M12(AN78M12F)	(1)	222780125MAT		<B CMDC>
Q4170 or	IC	MPC78M12AHF-AZ	(1)	222780125NEC		<B CMDC>
Q4171	IC	79M12HF(NJM79M12FA)	1	222790125JRC		<B CMDC>
Q4171 or	IC	79M12F(AN79M12F)	(1)	222790125MAT		<B CMDC>
Q4171 or	IC	79M12HF(MPC79M12HF)	(1)	222790125NEC		<B CMDC>
Q6001	IC	STK-443-530-E	1	222148		
Q6002	IC	STK-443-530-E	1	222148		<B CMDC>
Q6010	TR	2SC2240-BL(TPE2_F)	1	2211406T		
Q6011	TR	2SC2240-BL(TPE2_F)	1	2211406T		
Q6012	TR	2SC2240-BL(TPE2_F)	1	2211406T		
Q6013	TR	2SC2240-BL(TPE2_F)	1	2211406T		
Q6014	TR	2SC2240-BL(TPE2_F)	1	2211406T		
Q6017	TR	2SC2240-BL(TPE2_F)	1	2211406T		<B CMDC>
Q6021	TR	2SA1163-BL(TE85L_F)	1	2216756R2		
Q6022	TR	2SC2240-BL(TPE2_F)	1	2211406T		
Q6023	TR	2SC2240-BL(TPE2_F)	1	2211406T		
Q6024	TR	2SA1163-BL(TE85L_F)	1	2216756R2		
Q6051	TR	KRC105S	1	2217290R2		
Q6051 or	TR	RN1405	(1)	2214500R2		
Q6051 or	TR	DTC123JKA	(1)	2216690R2		
Q6052	TR	KRC105S	1	2217290R2		

Q6052 or	TR	RN1405	(1)	2214500R2	
Q6052 or	TR	DTC123JKA	(1)	2216690R2	
Q6053	TR	KRC105S	1	2217290R2	
Q6053 or	TR	RN1405	(1)	2214500R2	
Q6053 or	TR	DTC123JKA	(1)	2216690R2	
Q6055	TR	KRC105S	1	2217290R2	
Q6055 or	TR	RN1405	(1)	2214500R2	
Q6055 or	TR	DTC123JKA	(1)	2216690R2	
Q6057	TR	KRC105S	1	2217290R2	<B CMDC>
Q6057 or	TR	RN1405	(1)	2214500R2	<B CMDC>
Q6057 or	TR	DTC123JKA	(1)	2216690R2	<B CMDC>
Q6380	IC	LM61CIZ	1	22242212	
Q6380A	RETAINER	(PTH)	1	27141884-1	
Q6707	TR	KTC3875-GR	1	2216175R2	
Q6707 or	TR	2SC2712-GR	(1)	2213145R2	
Q960	TR	2SC2235-Y(TPE6_F)	1	2211654T	
Q960 or	TR	2SC2235-O(TPE6_F)	(1)	2211653T	
<b>[CHASSIS SCREW]</b>					
Q4170A	HEAT-SINK	HEAT-SINK(RAD-68)	1		NSP
Q4170B	SCREW	3P+10FN(3BC)	1		NSP
Q4171A	HEAT-SINK	HEAT-SINK(RAD-68)	1		NSP
Q4171B	SCREW	3P+10FN(3BC)	1		NSP
<b>[TRANS COIL]</b>					
L4001	CHOKER COIL	LBC2518T2R2M	1	231364M022R2	
L6000	S COIL	SC-0.8X6.0X29.5T-4RV-C	1	231394AS	
L6000 or	S COIL	PB9510	(1)	231361	
L6001	S COIL	SC-0.8X6.0X29.5T-4RV-C	1	231394AS	
L6001 or	S COIL	PB9510	(1)	231361	
L6002	S COIL	SC-0.8X6.0X29.5T-4RV-C	1	231394AS	
L6002 or	S COIL	PB9510	(1)	231361	
L6003	S COIL	SC-0.8X6.0X29.5T-4RV-C	1	231394AS	
L6003 or	S COIL	PB9510	(1)	231361	
L6004	S COIL	SC-0.8X6.0X29.5T-4RV-C	1	231394AS	
L6004 or	S COIL	PB9510	(1)	231361	
L6007	S COIL	SC-0.8X6.0X29.5T-4RV-C	1	231394AS	<B CMDC>
L6007 or	S COIL	PB9510	(1)	231361	<B CMDC>
<b>[CAPACITOR]</b>					
C4001	C-CERA C	CC725CH1H-152J1	1		NSP
C4002	C-CERA C	CC725CH1H-152J1	1		NSP
C4003	UPZ C	2AUPZTF221JE	1	376332214T	
C4004	UPZ C	2AUPZTF221JE	1	376332214T	
C4007	C-CERA C	CC725CH1H-221J1	1		NSP
C4008	C-CERA C	CC725CH1H-221J1	1		NSP

C4013	C-CERA C	CC725CH1H-221J1	1		NSP
C4014	C-CERA C	CC725CH1H-221J1	1		NSP
C4017	C-CERA C	CC725CH1H-221J1	1		NSP
C4018	C-CERA C	CC725CH1H-221J1	1		NSP
C4019	UPZ C	2AUPZTF221JE	1	376332214T	
C4020	UPZ C	2AUPZTF221JE	1	376332214T	
C4050	UTSP C	CE04W25V-47M(UTSP)	1	397554707T	
C4051	UTSP C	CE04W25V-47M(UTSP)	1	397554707T	
C4052	UTSP C	CE04W25V-47M(UTSP)	1	397554707T	
C4053	UTSP C	CE04W25V-47M(UTSP)	1	397554707T	
C4054	UTSP C	CE04W25V-47M(UTSP)	1	397554707T	
C4057	UTSP C	CE04W25V-47M(UTSP)	1	397554707T	
C4060	UTSP C	CE04W50V 47M(UTSP)	1	397584707T	
C4061	UTSP C	CE04W50V 47M(UTSP)	1	397584707T	
C4062	TF C	ECQ-V50V-474J	1	374724744T	
C4063	TF C	ECQ-V50V-823J	1	374728234T	
C4064	TF C	ECQ-V50V-223J	1	374722234T	
C4065	TF C	ECQ-V50V-474J	1	374724744T	
C4066	TF C	ECQ-V50V-823J	1	374728234T	
C4067	TF C	ECQ-V50V-223J	1	374722234T	
C4070	UTSP C	CE04W50V 47M(UTSP)	1	397584707T	
C4071	UTSP C	CE04W50V 47M(UTSP)	1	397584707T	
C4072	UTSP C	CE04W50V 47M(UTSP)	1	397584707T	
C4073	UTSP C	CE04W50V 47M(UTSP)	1	397584707T	
C4074	UTSP C	CE04W50V 47M(UTSP)	1	397584707T	
C4077	UTSP C	CE04W50V 47M(UTSP)	1	397584707T	
C4085	UTSP C	CE04W25V-47M(UTSP)	1	397554707T	
C4086	UTSP C	CE04W25V-47M(UTSP)	1	397554707T	
C4090	C-CERA C	CC725CH1H-101J1	1	342101014R1	
C4091	C-CERA C	CC725CH1H-101J1	1	342101014R1	
C4100	UTSP C	CE04W50V 47M(UTSP)	1	397584707T	
C4101	UTSP C	CE04W50V 47M(UTSP)	1	397584707T	
C4102	UTSP C	CE04W50V 47M(UTSP)	1	397584707T	
C4103	UTSP C	CE04W50V 47M(UTSP)	1	397584707T	
C4104	UTSP C	CE04W50V 47M(UTSP)	1	397584707T	
C4107	UTSP C	CE04W50V-2.2M(UTSP)	1	397580227T	<B CMDC>
C4130	UTSP C	CE04W50V 47M(UTSP)	1	397584707T	
C4131	C-CERA C	CC725CH1H-221J1	1	342102214R1	
C4132	TF C	ECQ-V50V-103J	1	374721034T	
C4166	UTSP C	CE04W25V-220M(UTSP)	1	397552217T	
C4167	UTSP C	CE04W25V-220M(UTSP)	1	397552217T	
C4170	UTSP C	CE04W50V-1M(UTSP)	1	397580107T	
C4171	UTSP C	CE04W50V-1M(UTSP)	1	397580107T	

C4172	UTSP C	CE04W25V-220M(UTSP)	1	397552217T		
C4173	UTSP C	CE04W25V-220M(UTSP)	1	397552217T		
C4186	UTSP C	CE04W16V-470M(UTSP)	1	397544717T		
C4187	UTSP C	CE04W16V-470M(UTSP)	1	397544717T		
C4203	C-CERA C	CC725CH1H-102J1	1			NSP
C4204	C-CERA C	CC725CH1H-102J1	1			NSP
C4205	C-CERA C	CC725CH1H-102J1	1			NSP
C4209	UTSP C	CE04W25V-47M(UTSP)	1	397554707T		
C4210	UTSP C	CE04W25V-47M(UTSP)	1	397554707T		
C4300	TF C	ECQ-V50V-334J	1	374723344T		
C4301	VR C	CE04W35V-1000M(VR)	1	394661027S		
C4302	VR C	CE04W35V-470M(VR)	1	394664717T		
C6009	TF C	ECQ-V50V-333J	1	374723334T		
C6010	UTSP C	CE04W50V 47M(UTSP)	1	397584707T		
C6011	UTSP C	CE04W50V 47M(UTSP)	1	397584707T		
C6012	UTSP C	CE04W50V 47M(UTSP)	1	397584707T		
C6013	UTSP C	CE04W50V 47M(UTSP)	1	397584707T		
C6014	UTSP C	CE04W50V 47M(UTSP)	1	397584707T		
C6017	UTSP C	CE04W50V 47M(UTSP)	1	397584707T		<B CMDC>
C6020	UPZ C	2AUPZTF471JE	1	376334714T		
C6021	UPZ C	2AUPZTF471JE	1	376334714T		
C6022	UPZ C	2AUPZTF471JE	1	376334714T		
C6023	UPZ C	2AUPZTF471JE	1	376334714T		
C6024	UPZ C	2AUPZTF471JE	1	376334714T		
C6027	UPZ C	2AUPZTF471JE	1	376334714T		<B CMDC>
C6030	UTSP C	CE04W25V-220M(UTSP)	1	397552217T		
C6031	UTSP C	CE04W25V-220M(UTSP)	1	397552217T		
C6032	UTSP C	CE04W25V-220M(UTSP)	1	397552217T		
C6033	UTSP C	CE04W25V-220M(UTSP)	1	397552217T		
C6034	UTSP C	CE04W25V-220M(UTSP)	1	397552217T		
C6037	UTSP C	CE04W25V-220M(UTSP)	1	397552217T		<B CMDC>
C6040	CERA C	CC45CH50V-030D	1	345340302T		
C6041	CERA C	CC45CH50V-030D	1	345340302T		
C6042	CERA C	CC45CH50V-030D	1	345340302T		
C6043	CERA C	CC45CH50V-030D	1	345340302T		
C6044	CERA C	CC45CH50V-030D	1	345340302T		
C6047	CERA C	CC45CH50V-030D	1	345340302T		<B CMDC>
C6050	C-CERA C	CK725B1H-472K1	1			NSP
C6051	C-CERA C	CK725B1H-472K1	1			NSP
C6052	C-CERA C	CK725B1H-472K1	1			NSP
C6053	C-CERA C	CK725B1H-472K1	1			NSP
C6054	C-CERA C	CK725B1H-472K1	1			NSP
C6057	C-CERA C	CK725B1H-472K1	1			NSP <B CMDC>

C6060	TF C	ECQ-V50V-473J	1	374724734T	
C6061	TF C	ECQ-V50V-473J	1	374724734T	
C6062	TF C	ECQ-V50V-473J	1	374724734T	
C6063	TF C	ECQ-V50V-473J	1	374724734T	
C6064	TF C	ECQ-V50V-473J	1	374724734T	
C6067	TF C	ECQ-V50V-473J	1	374724734T	<B CMDC>
C6070	TF C	ECQ-V50V-103J	1	374721034T	
C6071	TF C	ECQ-V50V-103J	1	374721034T	
C6072	TF C	ECQ-V50V-103J	1	374721034T	
C6073	TF C	ECQ-V50V-103J	1	374721034T	
C6074	TF C	ECQ-V50V-103J	1	374721034T	
C6077	TF C	ECQ-V50V-103J	1	374721034T	<B CMDC>
C6080	MKT C	B32529C0102J289	1	376491024T	<B CMDC>
C6081	MKT C	B32529C0102J289	1	376491024T	<B CMDC>
C6082	MKT C	B32529C0102J289	1	376491024T	<B CMDC>
C6083	MKT C	B32529C0102J289	1	376491024T	<B CMDC>
C6084	MKT C	B32529C0102J289	1	376491024T	<B CMDC>
C6087	MKT C	B32529C0102J289	1	376491024T	<B CMDC>
C6088	MKT C	B32529C0102J289	1	376491024T	<B CMDC>
C6089	MKT C	B32529C0102J289	1	376491024T	<B CMDC>
C6090	UTSP C	CE04W25V-100M(UTSP)	1	397551017T	
C6091	UTSP C	CE04W50V-1M(UTSP)	1	397580107T	
C6092	UTSP C	CE04W50V-1M(UTSP)	1	397580107T	
C6093	C-CERA C	CK725F1E-104Z1	1		NSP
C6094	C-CERA C	CK725F1E-104Z1	1		NSP
C6101	UTSP C	CE04W63V-100M(UTSP)	1	397571017T	
C6102	UTSP C	CE04W63V-100M(UTSP)	1	397571017T	
C6103	UTSP C	CE04W50V 47M(UTSP)	1	397584707T	
C6104	UTSP C	CE04W63V-100M(UTSP)	1	397571017T	
C6105	UTSP C	CE04W63V-100M(UTSP)	1	397571017T	
C6106	UTSP C	CE04W50V 47M(UTSP)	1	397584707T	
C6107	UTSP C	CE04W63V-100M(UTSP)	1	397571017T	
C6108	UTSP C	CE04W63V-100M(UTSP)	1	397571017T	
C6111	TF C	ECQ-V50V-103J	1	374721034T	
C6112	TF C	ECQ-V50V-103J	1	374721034T	
C6113	TF C	ECQ-V50V-103J	1	374721034T	
C6115	TF C	ECQ-V50V-103J	1	374721034T	
C6117	TF C	ECQ-V50V-103J	1	374721034T	<B CMDC>
C6706	UTSP C	CE04W50V-10M(UTSP)	1	397581007T	
C6901	ELECT C	CE69W56V-8200MB	1	3504416	<B CMDC>
C6902	ELECT C	CE69W56V-8200MB	1	3504416	<B CMDC>
C6911	C-CERA C	CC725CH1H-102J1	1	342101024R1	
C6912	TF C	ECQ-V50V-334J	1	374723344T	

C6913	TF C	ECQ-V50V-334J	1	374723344T	
C950	TF C	ECQ-V50V-104J	1	374721044T	
C960	VR C	CE04W63V-220M(VR)	1	394672217T	
C961	VR C	CE04W50V-47M(VR)	1	394684707T	
C962	C-CERA C	CK725F1E-104Z1	1		NSP
<b>[RESISTOR]</b>					
R4000	C-CARBON R	RN72K1J-331JE	1		NSP
R4001	METAL O R	RS1WBJ-10	1	443621004T	<B CMDC>
R4003	C-CARBON R	RN72K1J-331JE	1		NSP
R4004	C-CARBON R	RN72K1J-331JE	1		NSP
R4005	METAL O R	RS1WBJ-15	1	443621504T	<B CMDC>
R4007	C-CARBON R	RN72K1J-331JE	1		NSP
R4008	C-CARBON R	RN72K1J-331JE	1		NSP
R4013	C-CARBON R	RN72K1J-331JE	1		NSP
R4014	C-CARBON R	RN72K1J-331JE	1		NSP
R4015	C-CARBON R	RN72K1J-222JE	1		NSP
R4016	C-CARBON R	RN72K1J-222JE	1		NSP
R4017	C-CARBON R	RN72K1J-331JE	1		NSP
R4018	C-CARBON R	RN72K1J-331JE	1		NSP
R4019	C-CARBON R	RN72K1J-331JE	1		NSP
R4020	C-CARBON R	RN72K1J-331JE	1		NSP
R4023	C-CARBON R	RN72K1J-000JE	1		NSP
R4043	C-CARBON R	RN72K1J-104JE	1		NSP
R4044	C-CARBON R	RN72K1J-104JE	1		NSP
R4047	C-CARBON R	RN72K1J-104JE	1		NSP
R4048	C-CARBON R	RN72K1J-104JE	1		NSP
R4053	C-CARBON R	RN72K1J-104JE	1		NSP
R4054	C-CARBON R	RN72K1J-104JE	1		NSP
R4055	C-CARBON R	RN72K1J-224JE	1		NSP
R4056	C-CARBON R	RN72K1J-224JE	1		NSP
R4057	C-CARBON R	RN72K1J-104JE	1		NSP
R4058	C-CARBON R	RN72K1J-104JE	1		NSP
R4059	C-CARBON R	RN72K1J-104JE	1		NSP
R4060	C-CARBON R	RN72K1J-104JE	1		NSP
R4067	C-CARBON R	RN72K1J-104JE	1		NSP
R4068	C-CARBON R	RN72K1J-104JE	1		NSP
R4078	C-CARBON R	RN72K1J-473JE	1		NSP
R4079	C-CARBON R	RN72K1J-473JE	1		NSP
R4080	C-CARBON R	RN72K1J-104JE	1		NSP
R4081	C-CARBON R	RN72K1J-104JE	1		NSP
R4082	C-CARBON R	RN72K1J-104JE	1		NSP
R4085	C-CARBON R	RN72K1J-182JE	1		NSP
R4086	C-CARBON R	RN72K1J-182JE	1		NSP

R4087	C-CARBON R	RN72K1J-103JE	1		NSP	
R4088	C-CARBON R	RN72K1J-103JE	1		NSP	
R4089	C-CARBON R	RN72K1J-000JE	1		NSP	
R4090	C-CARBON R	RN72K1J-123JE	1		NSP	
R4091	C-CARBON R	RN72K1J-223JE	1		NSP	
R4092	C-CARBON R	RN72K1J-331JE	1		NSP	
R4093	C-CARBON R	RN72K1J-332JE	1		NSP	
R4094	C-CARBON R	RN72K1J-103JE	1		NSP	
R4095	C-CARBON R	RN72K1J-103JE	1		NSP	
R4096	C-CARBON R	RN72K1J-331JE	1		NSP	
R4097	C-CARBON R	RN72K1J-332JE	1		NSP	
R4098	C-CARBON R	RN72K1J-123JE	1		NSP	
R4099	C-CARBON R	RN72K1J-223JE	1		NSP	
R4100	C-CARBON R	RN72K1J-224JE	1		NSP	
R4101	C-CARBON R	RN72K1J-224JE	1		NSP	
R4102	C-CARBON R	RN72K1J-224JE	1		NSP	
R4103	C-CARBON R	RN72K1J-224JE	1		NSP	
R4104	C-CARBON R	RN72K1J-224JE	1		NSP	
R4107	C-CARBON R	RN72K1J-222JE	1		NSP	<B CMDC>
R4110	C-CARBON R	RN72K1J-222JE	1		NSP	
R4111	C-CARBON R	RN72K1J-222JE	1		NSP	
R4112	C-CARBON R	RN72K1J-222JE	1		NSP	
R4113	C-CARBON R	RN72K1J-222JE	1		NSP	
R4114	C-CARBON R	RN72K1J-222JE	1		NSP	
R4117	C-CARBON R	RN72K1J-271JE	1		NSP	
R4127	C-CARBON R	RN72K1J-101JE	1		NSP	
R4130	C-CARBON R	RN72K1J-221JE	1		NSP	
R4131	C-CARBON R	RN72K1J-473JE	1		NSP	
R4132	C-CARBON R	RN72K1J-153JE	1		NSP	
R4133	C-CARBON R	RN72K1J-122JE	1		NSP	
R4134	C-CARBON R	RN72K1J-103JE	1		NSP	
R4160	METAL R	RNU1WCJ-0.22	1	453632294T		
R4161	METAL R	RNU1WCJ-0.22	1	453632294T		
R4166	C-CARBON R	RN72K1J-220JE	1		NSP	
R4167	C-CARBON R	RN72K1J-220JE	1		NSP	
R4174	METAL O R	RS1WBJ-68	1	443626804T		
R4175	METAL O R	RS1WBJ-68	1	443626804T		
R4176	METAL O R	RS1WBJ-15	1	443621504T		<B CMDC>
R4177	METAL O R	RS1WBJ-15	1	443621504T		<B CMDC>
R4181	C-CARBON R	RN72K1J-224JE	1		NSP	
R4189	C-CARBON R	RN72K1J-224JE	1		NSP	
R4190	C-CARBON R	RN72K1J-224JE	1		NSP	
R4192	C-CARBON R	RN72K1J-224JE	1		NSP	



R4193	C-CARBON R	RN72K1J-224JE	1		NSP	
R4194	C-CARBON R	RN72K1J-224JE	1		NSP	
R4303	C-CARBON R	RN72K1J-512JE	1		NSP	
R4304	C-CARBON R	RN72K1J-512JE	1		NSP	
R6010	C-CARBON R	RN72K1J-102JE	1		NSP	
R6011	C-CARBON R	RN72K1J-102JE	1		NSP	
R6012	C-CARBON R	RN72K1J-102JE	1		NSP	
R6013	C-CARBON R	RN72K1J-102JE	1		NSP	
R6014	C-CARBON R	RN72K1J-102JE	1		NSP	
R6017	C-CARBON R	RN72K1J-102JE	1		NSP	<B CMDC>
R6020	CARBON R	R16J-56K	1	417345634T		
R6021	CARBON R	R16J-56K	1	417345634T		
R6022	CARBON R	R16J-56K	1	417345634T		
R6023	CARBON R	R16J-56K	1	417345634T		
R6024	CARBON R	R16J-56K	1	417345634T		
R6027	CARBON R	R16J-56K	1	417345634T		<B CMDC>
R6030	CARBON R	R16J-2.2K	1	417342224T		
R6031	CARBON R	R16J-2.2K	1	417342224T		
R6032	CARBON R	R16J-2.2K	1	417342224T		
R6033	CARBON R	R16J-2.2K	1	417342224T		
R6034	CARBON R	R16J-2.2K	1	417342224T		
R6037	CARBON R	R16J-2.2K	1	417342224T		<B CMDC>
R6040	CARBON R	R16J-120K	1	417341244T		
R6041	CARBON R	R16J-120K	1	417341244T		
R6042	CARBON R	R16J-120K	1	417341244T		
R6043	CARBON R	R16J-120K	1	417341244T		
R6044	CARBON R	R16J-120K	1	417341244T		
R6047	CARBON R	R16J-120K	1	417341244T		<B CMDC>
R6050	CARBON R	R16J-120K	1	417341244T		
R6051	CARBON R	R16J-120K	1	417341244T		
R6052	CARBON R	R16J-120K	1	417341244T		
R6053	CARBON R	R16J-120K	1	417341244T		
R6054	CARBON R	R16J-120K	1	417341244T		
R6057	CARBON R	R16J-120K	1	417341244T		<B CMDC>
R6060	METAL PR	MPR2W+2W 0R22	1	4000234		
R6060 or	METAL P R	RF-2EGPJR22	(1)	4000243		
R6061	METAL PR	MPR2W+2W 0R22	1	4000234		
R6061 or	METAL P R	RF-2EGPJR22	(1)	4000243		
R6062	METAL PR	MPR2W+2W 0R22	1	4000234		
R6062 or	METAL P R	RF-2EGPJR22	(1)	4000243		
R6063	METAL PR	MPR2W+2W 0R22	1	4000234		
R6063 or	METAL P R	RF-2EGPJR22	(1)	4000243		
R6064	METAL PR	MPR2W+2W 0R22	1	4000234		

R6064 or	METAL P R	RF-2EGPJR22	(1)	4000243		
R6067	METAL PR	MPR2W+2W 0R22	1	4000234		<B CMDC>
R6067 or	METAL P R	RF-2EGPJR22	(1)	4000243		<B CMDC>
R6070	C-CARBON R	RN72K1J-563JE	1		NSP	
R6071	C-CARBON R	RN72K1J-563JE	1		NSP	
R6072	C-CARBON R	RN72K1J-563JE	1		NSP	
R6073	C-CARBON R	RN72K1J-563JE	1		NSP	
R6074	C-CARBON R	RN72K1J-563JE	1		NSP	
R6077	C-CARBON R	RN72K1J-563JE	1		NSP	<B CMDC>
R6080	C-CARBON R	RN72K1J-123JE	1		NSP	
R6081	C-CARBON R	RN72K1J-123JE	1		NSP	
R6082	C-CARBON R	RN72K1J-123JE	1		NSP	
R6083	C-CARBON R	RN72K1J-123JE	1		NSP	
R6084	C-CARBON R	RN72K1J-123JE	1		NSP	
R6087	C-CARBON R	RN72K1J-123JE	1		NSP	<B CMDC>
R6100	C-CARBON R	RN72K1J-333JE	1		NSP	
R6101	C-CARBON R	RN72K1J-333JE	1		NSP	
R6102	C-CARBON R	RN72K1J-333JE	1		NSP	
R6103	C-CARBON R	RN72K1J-333JE	1		NSP	
R6104	C-CARBON R	RN72K1J-333JE	1		NSP	
R6107	C-CARBON R	RN72K1J-333JE	1		NSP	<B CMDC>
R6110	C-CARBON R	RN72K1J-473JE	1		NSP	
R6111	C-CARBON R	RN72K1J-473JE	1		NSP	
R6112	C-CARBON R	RN72K1J-473JE	1		NSP	
R6113	C-CARBON R	RN72K1J-473JE	1		NSP	
R6114	C-CARBON R	RN72K1J-473JE	1		NSP	
R6117	C-CARBON R	RN72K1J-473JE	1		NSP	<B CMDC>
R6120	C-CARBON R	RN72K1J-473JE	1		NSP	
R6121	C-CARBON R	RN72K1J-473JE	1		NSP	
R6122	C-CARBON R	RN72K1J-473JE	1		NSP	
R6123	C-CARBON R	RN72K1J-473JE	1		NSP	
R6124	C-CARBON R	RN72K1J-473JE	1		NSP	
R6127	C-CARBON R	RN72K1J-473JE	1		NSP	<B CMDC>
R6130	C-CARBON R	RN72K2E-150JE	1		NSP	
R6131	C-CARBON R	RN72K2E-150JE	1		NSP	
R6132	C-CARBON R	RN72K2E-150JE	1		NSP	
R6133	C-CARBON R	RN72K2E-150JE	1		NSP	
R6134	C-CARBON R	RN72K2E-150JE	1		NSP	
R6137	C-CARBON R	RN72K2E-150JE	1		NSP	<B CMDC>
R6140	METAL R	RNU1WCJ-8.2	1	453630824T		
R6141	METAL R	RNU1WCJ-8.2	1	453630824T		
R6142	METAL R	RNU1WCJ-8.2	1	453630824T		
R6143	METAL R	RNU1WCJ-8.2	1	453630824T		

R6144	METAL R	RNU1WCJ-8.2	1	453630824T		
R6147	METAL R	RNU1WCJ-8.2	1	453630824T		<B CMDC>
R6203	CARBON R	R16J-33K	1	417343334T		
R6204	METAL O R	RS1WBJ-100	1	441621014F		
R6205	METAL O R	RS1WBJ-100	1	441621014F		
R6208	CARBON R	R16J-33K	1	417343334T		
R6209	METAL O R	RS1WBJ-100	1	441621014F		
R6210	METAL O R	RS1WBJ-100	1	441621014F		
R6211	C-CARBON R	RN72K1J-333JE	1			NSP
R6213	C-CARBON R	RN72K1J-103JE	1			NSP
R6214	C-CARBON R	RN72K1J-473JE	1			NSP
R6216	C-CARBON R	RN72K1J-224JE	1			NSP
R6217	C-CARBON R	RN72K1J-473JE	1			NSP
R6218	C-CARBON R	RN72K1J-103JE	1			NSP
R6219	C-CARBON R	RN72K1J-224JE	1			NSP
R6230	C-CARBON R	RN72K2E-150JE	1			NSP
R6231	C-CARBON R	RN72K2E-150JE	1			NSP
R6232	C-CARBON R	RN72K2E-150JE	1			NSP
R6233	C-CARBON R	RN72K2E-150JE	1			NSP
R6234	C-CARBON R	RN72K2E-150JE	1			NSP
R6237	C-CARBON R	RN72K2E-150JE	1			NSP <B CMDC>
R6251	METAL O R	RS1/2WBJ-390	1	443523914T		
R6252	METAL O R	RS1/2WBJ-390	1	443523914T		
R6302	METAL O R	RS1WBJ-33	1	443623304T		
R6303	METAL O R	RS1WBJ-470	1	443624714T		
R6304	METAL O R	RS1WBJ-470	1	443624714T		
R6305	METAL O R	RS1WBJ-470	1	443624714T		
R6306	METAL O R	RS1WBJ-470	1	443624714T		
R6307	METAL O R	RS1WBJ-470	1	443624714T		
R6308	METAL O R	RS1WBJ-470	1	443624714T		
R6309	METAL O R	RS1WBJ-470	1	443624714T		
R6310	METAL O R	RS1WBJ-470	1	443624714T		
R6316	METAL O R	RS1/2WBJ-10	1	443521004T		<B CMDC>
R6322	METAL O R	RS1WBJ-22	1	443622204T		<B CMDC>
R6327	METAL O R	RS1WBJ-470	1	443624714T		<B CMDC>
R6337	METAL O R	RS1WBJ-470	1	443624714T		<B CMDC>
R6709	C-CARBON R	RN72K1J-562JE	1			NSP
R6710	C-CARBON R	RN72K1J-562JE	1			NSP
R6902	C-CARBON R	RN72K1J-102JE	1			NSP
R6903	C-CARBON R	RN72K1J-473JE	1			NSP
R6912	C-CARBON R	RN72K1J-000JE	1			NSP
R950	METAL O R	RS1WBJ-10	1	443621004T		
R960	METAL R	RNU1/2WCJ-8.2	1	453530824T		

R961	METAL R	RNU1/2WCJ-3.3	1	453530334T	
R962	C-CARBON R	RN72K1J-822JE	1		NSP
R963	C-CARBON R	RN72K1J-822JE	1		NSP
R964	C-CARBON R	RN72K1J-333JE	1		NSP
<b>[SW TRM]</b>					
E6001	RETAINER	MET37-0002	1		NSP
F6901A	FUSE HOL	NSCT-1P2031	1	25052133T	
F6901B	FUSE HOL	NSCT-1P2031	1	25052133T	
F6902A	FUSE HOL	NSCT-1P2031	1	25052133T	
F6902B	FUSE HOL	NSCT-1P2031	1	25052133T	
JL501A	WIRE HOL	NSCT-3P874	1	25051087	
JL502A	WIRE HOL	NSCT-5P876	1	25051089	
JL600A	WIRE HOL	NSCT-7P898	1	25051111	
JL600B	WIRE HOL	NSCT-7P898	1	25051111	
JL603A	WIRE HOL	NSCT-9P900	1	25051113	
JL603B	WIRE HOL	NSCT-9P900	1	25051113	
JL605B	SOCKET	NSCT-5P97	1	25050269	
JL951A	WIRE HOL	NSCT-5P896	1	25051109	
JL951B	SOCKET	NSCT-5P97	1	25050269	
JL952A	WIRE HOL	NSCT-3P894	1	25051107	
JL953B	WIRE TRAP	NPLG-5P588	1	25055626	
JL954A	WIRE HOL	NSCT-9P900	1	25051113	
JL954B	WIRE HOL	NSCT-9P900	1	25051113	
P4000	ST JACK	MSJ-035-22	1	25045887	
P4000 or	JACK	YKB21-5130	(1)	25045387	
P4002	PIN JACK	NPJ-2PDWR595	1	25045815	
P4003	PIN JACK	NPJ-2PDWR558	1	25045776	
P4003 or	PIN JACK	NPJ-2PDBL185	(1)	25045333	
P4005	PIN JACK	NPJ-4PDWWRR624	1	25045845	
P4005 or	PIN JACK	NPJ-4PDBL162	(1)	25045303	
P4006	PIN JACK	NPJ-4PDWWRR624	1	25045845	
P4006 or	PIN JACK	NPJ-4PDBL162	(1)	25045303	
P5501B	PLUG	NPLG-7P0962	1	25056012	
P5502B	PLUG	NPLG-15P0970	1	25056020	
P5503B	PLUG	NPLG-9P0964	1	25056014	
P5504B	PLUG	NPLG-7P0962	1	25056012	
P6001	TRM	NTM-12PDML362	1	25060433	<B CMDC>
P6001 or	TRM	NTM-12PDML356	(1)	25060427	<B CMDC>
P6002	TRM	NTM-4PDMNRR420	1	25060492	
P6900	CRIMP AS	CRIMP AS	1	20799162UL	
P6901	CRIMP AS	CRIMP AS	1	2069925162UL	
P6902	CRIMP AS	CRIMP AS	1	2069925169UL	N
P6903	WS CLAMP	CB-71683(L=50)	1	260261	

P6906	WS CLAMP	CB-71683(L=50)	1	260261	
P6909	WS CLAMP	CB-71683(L=50)	1	260261	
P6913	WS CLAMP	CB-71683(L=50)	1	260261	
RL601	RELAY	NRL-2P5A-DC12-192	1	25065702	
RL602	RELAY	NRL-2P5A-DC12-192	1	25065702	
RL603	RELAY	NRL-2P5A-DC12-192	1	25065702	
RL605	RELAY	NRL-2P5A-DC12-192	1	25065702	
RL607	RELAY	NRL-2P5A-DC12-192	1	25065702	<B CMDC>
RL691	RELAY	NRL-1P10A-DC12-196	1	25065707	
RL691 or	RELAY	NRL-1P10A-DC12-197	(1)	25065708	
RL691 or	RELAY	NRL-1P10A-DC12-198	(1)	25065709	
RL692	RELAY	NRL-1P10A-DC12-196	1	25065707	
RL692 or	RELAY	NRL-1P10A-DC12-197	(1)	25065708	
RL692 or	RELAY	NRL-1P10A-DC12-198	(1)	25065709	

**HT-R280**

**PC BOARD PARTS LIST**

U003	DG-AS(MPU/DAC/DIR Assy) U0030+U0041	BADG-0364-1K *	1	1B247564-1K	280c
U0030	DG-AS(MPU/DAC/DIR Assy) U0030+U0041	BADG-0364-1K	1	1B2475364-1K	
U0031	PWB(U-PORT)	BADG-0365-1K	1	1B2475365-1K	N

CIRCUIT	PART NAME	DESCRIPTION	Q'TY	PART NO. (SN)	REMARKS
<b>[SEMI CONDUCTOR]</b>					
D110	C-DIODE	KDS4148U	1		NSP
D110 or	C-DIODE	1SS352	(1)		NSP
D110 or	C-DIODE	MA2J111	(1)		NSP
D111	C-DIODE	KDS4148U	1		NSP
D111 or	C-DIODE	1SS352	(1)		NSP
D111 or	C-DIODE	MA2J111	(1)		NSP
D112	ZENER D	UDZS10B	1	224551000R2	<B CMDC>
D131	C-DIODE	KDS4148U	1		NSP
D131 or	C-DIODE	1SS352	(1)		NSP
D131 or	C-DIODE	MA2J111	(1)		NSP
D132	C-DIODE	KDS4148U	1		NSP
D132 or	C-DIODE	1SS352	(1)		NSP
D132 or	C-DIODE	MA2J111	(1)		NSP
D182	DIODE	RL1N4003	1	22380260T	
D183	DIODE	RL1N4003	1	22380260T	
D601	C-DIODE	KDS4148U	1		NSP
D601 or	C-DIODE	1SS352	(1)		NSP
D601 or	C-DIODE	MA2J111	(1)		NSP
D701	C-DIODE	KDS4148U	1		NSP

D701 or	C-DIODE	1SS352	(1)		NSP
D701 or	C-DIODE	MA2J111	(1)		NSP
D702	C-DIODE	KDS4148U	1		NSP
D702 or	C-DIODE	1SS352	(1)		NSP
D702 or	C-DIODE	MA2J111	(1)	223279R2	
Q111	TR	2SC2235-Y(TPE6_F)	1	2211654T	<B CMDC>
Q131	IC	TC74HCU04AF	1	222740046R2TO	
Q131 or	IC	74HCU04F	(1)	222740046R2	
Q153	IC	R1EX25064ASA00A	1	22242581R2	
Q153 or	IC	M95640-WMN6TP	(1)	22242643R2	N
Q181	TR	KRC105S	1	2217290R2	
Q181 or	TR	RN1405	(1)	2214500R2	
Q2804	IC	NJM4580M-D	1	22241448R2	
Q301	IC	PCM9210PTR	1	22242629R2	N
Q302	IC	PCM1690DCAR	1	22242599R2	
Q401	IC	NJM4580M-D	1	22241448R2	
Q402	IC	NJM4580M-D	1	22241448R2	
Q403	IC	NJM4580M-D	1	22241448R2	
Q405	IC	NJM4580M-D	1	22241448R2	<B CMDC>
Q601	TR	KRC104S	1	2216210R2	
Q601 or	TR	RN1404	(1)	2214490R2	
Q701	IC (MMPU)	MPD70F3746(03450)IC(FLA	1	222W0079R303450	
Q702	IC	S-812C33AUA-C2N	1	22242222R2	
Q703	IC	S-812C56AUA-C3K	1	22242207R2	
Q704	IC	SN74CB3Q3305PWR	1	22242258R2	
Q746	IC	XC6221B332MR	1	22242633R2	
Q751	TR	KRC104S	1	2216210R2	
Q751 or	TR	RN1404	(1)	2214490R2	
Q752	TR	KRA102S	1	2216220R2	
Q752 or	TR	RN2402	(1)	2214530R2	
Q753	TR	KRA107S	1	2216350R2	
Q753 or	TR	RN2407(TE85L_F)	(1)	2216360R2	
Q754	TR	KRC102S	1	2216190R2	
Q754 or	TR	RN1402	(1)	2214470R2	
Q755	TR	KRA107S	1	2216350R2	
Q755 or	TR	RN2407(TE85L_F)	(1)	2216360R2	
Q756	TR	KRC102S	1	2216190R2	
Q756 or	TR	RN1402	(1)	2214470R2	
Q757	TR	KRC107S	1	2216340R2	
Q757 or	TR	RN1407	(1)	2216260R2	
<b>[TRANS COIL]</b>					
L131	CHOKE COIL	LBC2518T2R2M	1	231364M022R2	
L133	CHOKE COIL	LBC2518T470M	1	231364M470R2	

L134	CHOKE COIL	LBC2518T470M	1	231364M470R2		
L135	C-CARBON R	RN72K1J-000JE	1	435030004R1		
L153	CORE	BLM18PG181SN1D	1	2350005R1		
L2800	CORE	BLM18PG181SN1D	1	2350005R1		
L2801	CORE	BLM18PG181SN1D	1	2350005R1		
L2802	CORE	BLM18PG181SN1D	1	2350005R1		
L2803	EMIFIL	BK1608LM182-T	1	230958R1		
L2804	EMIFIL	BK1608LM182-T	1	230958R1		
L2805	EMIFIL	BK1608LM182-T	1	230958R1		
L2806	EMIFIL	BK1608LM182-T	1	230958R1		
L2807	EMIFIL	BK1608LM182-T	1	230958R1		
L2808	EMIFIL	BK1608LM182-T	1	230958R1		
L2809	EMIFIL	BK1608LM182-T	1	230958R1		
L2810	EMIFIL	BK1608LM182-T	1	230958R1		
L2811	EMIFIL	BK1608LM182-T	1	230958R1		
L2812	EMIFIL	BK1608LM182-T	1	230958R1		
L2813	EMIFIL	BK1608LM182-T	1	230958R1		
L2814	EMIFIL	BK1608LM182-T	1	230958R1		
L2815	EMIFIL	BK1608LM182-T	1	230958R1		
L2816	EMIFIL	BK1608LM182-T	1	230958R1		
L2817	EMIFIL	BK1608LM182-T	1	230958R1		
L2818	EMIFIL	BK1608LM182-T	1	230958R1		
L301	EMIFIL	BK1608LM182-T	1	230958R1		
L302	EMIFIL	BK1608LM182-T	1	230958R1		
L303	CHOKE COIL	LBC2518T4R7M	1	231364M047R2		
L304	CHOKE COIL	LBC2518T4R7M	1	231364M047R2		
L305	CHOKE COIL	LBC2518T4R7M	1	231364M047R2		
L307	C-CARBON R	RN72K1J-000JE	1	435030004R1		
L401	CHOKE COIL	LBC2518T4R7M	1	231364M047R2		
L402	CHOKE COIL	LBC2518T4R7M	1	231364M047R2		
L500	CORE	BLM18PG181SN1D	1	2350005R1		
L742	CHOKE COIL	BLM21PG221SN1	1	230949R2		
L743	CORE	BLM18PG181SN1D	1	2350005R1		
L744	CORE	BLM18PG181SN1D	1	2350005R1		
L746	CORE	BLM18PG181SN1D	1	2350005R1		
L747	CORE	BLM18PG181SN1D	1	2350005R1		
X171	CRYSTAL	HC-49US24.576MHz	1	3010490T		N
X501	CERA LOCK	CSTCR5M00G53-B0	1	3010356R2		
<b>[CAPACITOR]</b>						
C102	C-CERA C	CK725F1E-104Z1	1		NSP	<B CMDC>
C111	UTSP C	CE04W25V-47M(UTSP)	1	397554707T		<B CMDC>
C112	C-CERA C	CK725F1E-104Z1	1		NSP	<B CMDC>
C114	UTSP C	CE04W25V-47M(UTSP)	1	397554707T		<B CMDC>

C130	C-CERA C	CK725F1E-104Z1	1		NSP
C131	C-CERA C	CC725CH1H-101J1	1		NSP
C133	C-CERA C	CK725B1C-104K1	1		NSP
C135	C-CERA C	CC725CH1H-080D1	1		NSP
C139	UTSP C	CE04W10V-220M(UTSP)	1	397532217T	
C140	C-CERA C	CK725F1E-104Z1	1		NSP
C141	C-CERA C	CK725F1E-104Z1	1		NSP
C142	C-CERA C	CK725F1E-104Z1	1		NSP
C143	C-CERA C	CC725CH1H-330J1	1		NSP
C144	C-CERA C	CC725CH1H-330J1	1		NSP
C145	UTSP C	CE04W10V-220M(UTSP)	1	397532217T	
C151	C-CERA C	CK725F1E-104Z1	1		NSP
C172	C-CERA C	CC725CH1H-180J1	1		NSP
C173	C-CERA C	CC725CH1H-180J1	1		NSP
C2850	C-CERA C	CC725CH1H-471J1	1		NSP
C2851	C-CERA C	CC725CH1H-471J1	1		NSP
C2852	C-CERA C	CC725CH1H-470J1	1		NSP
C2855	C-CERA C	CK725F1E-104Z1	1		NSP
C2870	C-CERA C	CC725CH1H-101J1	1		NSP
C2871	C-CERA C	CC725CH1H-101J1	1		NSP
C2877	UTSP C	CE04W50V-10M(UTSP)	1	397581007T	
C2878	UTSP C	CE04W50V-10M(UTSP)	1	397581007T	
C2880	C-CERA C	CC725CH1H-101J1	1		NSP
C2881	C-CERA C	CC725CH1H-101J1	1		NSP
C2882	C-CERA C	CC725CH1H-101J1	1		NSP
C2883	C-CERA C	CC725CH1H-101J1	1		NSP
C2884	C-CERA C	CK725B1A-105K1	1		NSP
C2885	C-CERA C	CK725B1A-105K1	1		NSP
C2886	C-CERA C	CC725CH1H-471J1	1		NSP
C2887	C-CERA C	CC725CH1H-471J1	1		NSP
C2888	C-CERA C	CK725F1E-104Z1	1		NSP
C2889	C-CERA C	CK725F1E-104Z1	1		NSP
C2891	C-CERA C	CK725B1A-105K1	1		NSP
C2892	C-CERA C	CK725B1A-105K1	1		NSP
C2893	C-CERA C	CC725CH1H-471J1	1		NSP
C2894	C-CERA C	CC725CH1H-471J1	1		NSP
C2895	C-CERA C	CC725CH1H-471J1	1		NSP
C2896	C-CERA C	CC725CH1H-471J1	1		NSP
C2897	C-CERA C	CK725B1A-105K1	1		NSP
C2898	C-CERA C	CK725B1A-105K1	1		NSP
C305	C-CERA C	CK725F1E-104Z1	1		NSP
C306	UTSP C	CE04W10V-470M(UTSP)	1	397534717T	
C307	C-CERA C	CK725F1E-104Z1	1		NSP



C312	C-CERA C	CC725CH1H-221J1	1		NSP	
C313	C-CERA C	CK725F1E-104Z1	1		NSP	
C314	UTSP C	CE04W10V-470M(UTSP)	1	397534717T		
C315	C-CERA C	CK725B1H-472K1	1		NSP	
C316	C-CERA C	CK725B1H-473K1	1		NSP	
C317	C-CERA C	CK725F1E-104Z1	1		NSP	
C318	UTSP C	CE04W10V-470M(UTSP)	1	397534717T		
C319	UTSP C	CE04W25V-47M(UTSP)	1	397554707T		<B CMDC>
C320	C-CERA C	CK725B1H-223K1	1		NSP	
C351	UTSP C	CE04W10V-470M(UTSP)	1	397534717T		
C352	C-CERA C	CK725F1E-104Z1	1		NSP	
C353	UTSP C	CE04W10V-470M(UTSP)	1	397534717T		
C354	C-CERA C	CK725F1E-104Z1	1		NSP	
C355	C-CERA C	CK725F1E-104Z1	1		NSP	
C356	UTSP C	CE04W25V-47M(UTSP)	1	397554707T		<B CMDC>
C357	C-CERA C	CK725F1E-104Z1	1		NSP	
C400	UPZ C	2AUPZTF471JE	1	376334714T		<B CMDC>
C401	UPZ C	2AUPZTF471JE	1	376334714T		<B CMDC>
C402	UPZ C	2AUPZTF471JE	1	376334714T		
C403	UPZ C	2AUPZTF471JE	1	376334714T		
C404	UPZ C	2AUPZTF471JE	1	376334714T		
C407	UPZ C	2AUPZTF471JE	1	376334714T		
C410	UPZ C	2AUPZTF101JE	1	376331014T		<B CMDC>
C411	UPZ C	2AUPZTF101JE	1	376331014T		<B CMDC>
C412	UPZ C	2AUPZTF101JE	1	376331014T		
C413	C-CERA C	CC725CH1H-101J1	1		NSP	
C414	C-CERA C	CC725CH1H-101J1	1		NSP	
C417	UPZ C	2AUPZTF101JE	1	376331014T		
C420	UPZ C	2AUPZTF101JE	1	376331014T		<B CMDC>
C421	UPZ C	2AUPZTF101JE	1	376331014T		<B CMDC>
C422	UPZ C	2AUPZTF101JE	1	376331014T		
C423	C-CERA C	CC725CH1H-101J1	1	342101014R1		
C424	C-CERA C	CC725CH1H-101J1	1	342101014R1		
C427	UPZ C	2AUPZTF101JE	1	376331014T		
C470	UTSP C	CE04W50V-10M(UTSP)	1	397581007T		<B CMDC>
C471	UTSP C	CE04W50V-10M(UTSP)	1	397581007T		<B CMDC>
C472	C-CERA C	CK725B1A-105K1	1		NSP	<B CMDC>
C473	C-CERA C	CK725B1A-105K1	1		NSP	<B CMDC>
C498	UTSP C	CE04W25V-100M(UTSP)	1	397551017T		
C499	UTSP C	CE04W25V-100M(UTSP)	1	397551017T		
C501	UTSP C	CE04W50V-4.7M(UTSP)	1	397580477T		
C502	C-CERA C	CK725F1E-104Z1	1		NSP	
C503	C-CERA C	CK725F1E-104Z1	1		NSP	

C504	C-CERA C	CK725F1E-104Z1	1		NSP
C505	C-CERA C	CK725F1E-104Z1	1		NSP
C507	C-CERA C	CK725F1E-104Z1	1		NSP
C508	C-CERA C	CK725F1E-104Z1	1		NSP
C509	C-CERA C	CK725B0J-106K	1		NSP
C511	C-CERA C	CK725B1H-102K1	1		NSP
C512	C-CERA C	CK725B1H-102K1	1		NSP
C513	C-CERA C	CC725CH1H-101J1	1		NSP
C514	C-CERA C	CC725CH1H-101J1	1		NSP
C515	C-CERA C	CC725CH1H-101J1	1		NSP <B CMDC>
C516	C-CERA C	CC725CH1H-101J1	1		NSP <B CMDC>
C517	C-CERA C	CK725F1E-104Z1	1		NSP <B CMDC>
C518	C-CERA C	CK725B1H-102K1	1		NSP
C519	C-CERA C	CK725B1H-102K1	1		NSP
C520	C-CERA C	CK725B1H-102K1	1		NSP
C521	C-CERA C	CK725B1H-102K1	1		NSP <B CMDC>
C522	C-CERA C	CK725F1E-104Z1	1		NSP
C523	C-CERA C	CK725B1H-102K1	1		NSP
C524	C-CERA C	CK725B1H-102K1	1		NSP
C525	C-CERA C	CK725F1E-104Z1	1		NSP
C526	C-CERA C	CK725B1H-102K1	1		NSP
C527	C-CERA C	CK725B1H-102K1	1		NSP
C528	C-CERA C	CK725F1E-104Z1	1		NSP
C551	C-CERA C	CK725F1E-104Z1	1		NSP
C552	C-CERA C	CK725F1E-104Z1	1		NSP
C613	C-CERA C	CK732B1C-474K	1		NSP
C629	C-CERA C	CK725F1E-104Z1	1		NSP
C701	C-CERA C	CK725F1E-104Z1	1		NSP
C705	C-CERA C	CK725B0J-106K	1		NSP
C706	UTSP C	CE04W16V-470M(UTSP)	1	397544717T	
C707	UTSP C	CE04W10V-100M(UTSP)	1	397531017T	
C708	UTSP C	CE04W10V-470M(UTSP)	1	397534717T	
C709	C-CERA C	CK725F1E-104Z1	1		NSP
C710	C-CERA C	CK725F1E-104Z1	1		NSP
C744	C-CERA C	CK725F1E-104Z1	1		NSP
C745	C-CERA C	CK725B0J-106K	1		NSP
C748	UTSP C	CE04W10V-100M(UTSP)	1	397531017T	
C751	UTSP C	CE04W50V-0.47M(UTSP)	1	397584797T	
C753	UTSP C	CE04W10V-470M(UTSP)	1	397534717T	
C800	C-CERA C	CK725F1E-104Z1	1		NSP
C801	C-CERA C	CK725B1H-103K1	1		NSP
C802	C-CERA C	CK725F1E-104Z1	1		NSP

[RESISTOR]

R110	C-CARBON R	RN72K1J-103JE	1		NSP	
R112	METAL R	RNU1/2WCJ-4.7	1	453530474T		<B CMDC>
R113	C-CARBON R	RN72K1J-221JE	1		NSP	<B CMDC>
R114	C-CARBON R	RN72K1J-221JE	1		NSP	<B CMDC>
R115	C-CARBON R	RN72K1J-333JE	1		NSP	<B CMDC>
R131	C-CARBON R	RN72K1J-750JE	1		NSP	
R133	C-CARBON R	RN72K1J-100JE	1		NSP	
R137	C-CARBON R	RN72K1J-103JE	1		NSP	
R139	C-CARBON R	RN72K1J-823JE	1		NSP	
R141	C-CARBON R	RN72K1J-470JE	1		NSP	
R142	C-CARBON R	RN72K1J-470JE	1		NSP	
R151	C-CARBON R	RN72K1J-103JE	1		NSP	
R152	C-CARBON R	RN72K1J-103JE	1		NSP	
R153	C-CARBON R	RN72K1J-222JE	1		NSP	
R154	C-CARBON R	RN72K1J-103JE	1		NSP	
R181	METAL R	RNU1/2WCJ-4.7	1	453530474T		
R182	METAL R	RNU1/2WCJ-1	1	453530104T		
R2800	THERMISTOR	FUSB090F	1	4000252T		
R2804	C-CARBON R	RN72K1J-123JE	1		NSP	
R2805	C-CARBON R	RN72K1J-123JE	1		NSP	
R2806	C-CARBON R	RN72K1J-223JE	1		NSP	
R2807	C-CARBON R	RN72K1J-223JE	1		NSP	
R2808	C-CARBON R	RN72K1J-123JE	1		NSP	
R2809	C-CARBON R	RN72K1J-123JE	1		NSP	
R2810	C-CARBON R	RN72K1J-223JE	1		NSP	
R2811	C-CARBON R	RN72K1J-223JE	1		NSP	
R2820	C-CARBON R	RN72K1J-471JE	1		NSP	
R2821	C-CARBON R	RN72K1J-471JE	1		NSP	
R2830	C-CARBON R	RN72K1J-105JE	1		NSP	
R2848	C-CARBON R	RN72K1J-000JE	1		NSP	
R2849	C-CARBON R	RN72K1J-000JE	1		NSP	
R2852	C-CARBON R	RN72K1J-750JE	1		NSP	
R2861	C-CARBON R	RN72K1J-103JE	1		NSP	
R2862	C-CARBON R	RN72K1J-103JE	1		NSP	
R2863	C-CARBON R	RN72K1J-103JE	1		NSP	
R2864	C-CARBON R	RN72K1J-103JE	1		NSP	
R301	C-CARBON R	RN72K1J-470JE	1		NSP	
R302	C-CARBON R	RN72K1J-000JE	1		NSP	
R304	C-CARBON R	RN72K1J-221JE	1		NSP	
R305	C-CARBON R	RN72K1J-221JE	1		NSP	
R306	C-CARBON R	RN72K1J-330JE	1		NSP	
R307	C-CARBON R	RN72K1J-331JE	1		NSP	
R308	C-CARBON R	RN72K1J-331JE	1		NSP	

R312	C-CARBON R	RN72K1J-470JE	1		NSP
R313	C-CARBON R	RN72K1J-470JE	1		NSP
R314	C-CARBON R	RN72K1J-151JE	1		NSP
R315	C-CARBON R	RN72K1J-151JE	1		NSP
R316	C-CARBON R	RN72K1J-470JE	1		NSP
R317	C-CARBON R	RN72K1J-331JE	1		NSP
R321	C-CARBON R	RN72K1J-331JE	1		NSP
R322	C-CARBON R	RN72K1J-331JE	1		NSP
R324	C-CARBON R	RN72K1J-331JE	1		NSP
R325	C-CARBON R	RN72K1J-331JE	1		NSP
R326	C-CARBON R	RN72K1J-331JE	1		NSP
R327	C-CARBON R	RN72K1J-221JE	1		NSP
R331	C-CARBON R	RN72K1J-221JE	1		NSP
R332	C-CARBON R	RN72K1J-681JE	1		NSP
R333	C-CARBON R	RN72K1J-221JE	1		NSP
R341	C-CARBON R	RN72K1J-000JE	1		NSP
R350	C-CARBON R	RN72K1J-331JE	1		NSP
R351	C-CARBON R	RN72K1J-331JE	1		NSP
R352	C-CARBON R	RN72K1J-331JE	1		NSP
R354	C-CARBON R	RN72K1J-221JE	1		NSP
R355	C-CARBON R	RN72K1J-220JE	1		NSP
R356	C-CARBON R	RN72K1J-220JE	1		NSP
R357	C-CARBON R	RN72K1J-220JE	1		NSP
R358	C-CARBON R	RN72K1J-220JE	1		NSP
R359	C-CARBON R	RN72K1J-220JE	1		NSP
R360	C-CARBON R	RN72K1J-220JE	1		NSP
R361	C-CARBON R	RN72K1J-331JE	1		NSP
R362	C-CARBON R	RN72K1J-472JE	1		NSP
R371	C-CARBON R	RN72K1J-102JE	1		NSP
R400	C-CARBON R	RN72K1J-153JE	1		NSP
R401	C-CARBON R	RN72K1J-153JE	1		NSP
R402	C-CARBON R	RN72K1J-153JE	1		NSP
R403	C-CARBON R	RN72K1J-153JE	1		NSP
R404	C-CARBON R	RN72K1J-153JE	1		NSP
R407	C-CARBON R	RN72K1J-153JE	1		NSP
R410	C-CARBON R	RN72K1J-153JE	1		NSP
R411	C-CARBON R	RN72K1J-153JE	1		NSP
R412	C-CARBON R	RN72K1J-153JE	1		NSP
R413	C-CARBON R	RN72K1J-153JE	1		NSP
R414	C-CARBON R	RN72K1J-153JE	1		NSP
R417	C-CARBON R	RN72K1J-153JE	1		NSP
R420	C-CARBON R	RN72K1J-103JE	1		NSP <B CMDC>
R421	C-CARBON R	RN72K1J-103JE	1		NSP <B CMDC>

R430	C-CARBON R	RN72K1J-103JE	1		NSP	<B CMDC>
R431	C-CARBON R	RN72K1J-103JE	1		NSP	<B CMDC>
R440	C-CARBON R	RN72K1J-123JE	1		NSP	<B CMDC>
R441	C-CARBON R	RN72K1J-123JE	1		NSP	<B CMDC>
R442	C-CARBON R	RN72K1J-223JE	1		NSP	
R443	C-CARBON R	RN72K1J-223JE	1		NSP	
R444	C-CARBON R	RN72K1J-223JE	1		NSP	
R447	C-CARBON R	RN72K1J-223JE	1		NSP	
R450	C-CARBON R	RN72K1J-123JE	1		NSP	<B CMDC>
R451	C-CARBON R	RN72K1J-123JE	1		NSP	<B CMDC>
R452	C-CARBON R	RN72K1J-223JE	1		NSP	
R453	C-CARBON R	RN72K1J-223JE	1		NSP	
R454	C-CARBON R	RN72K1J-223JE	1		NSP	
R457	C-CARBON R	RN72K1J-223JE	1		NSP	
R460	C-CARBON R	RN72K1J-182JE	1		NSP	<B CMDC>
R461	C-CARBON R	RN72K1J-182JE	1		NSP	<B CMDC>
R462	C-CARBON R	RN72K1J-182JE	1		NSP	
R463	C-CARBON R	RN72K1J-182JE	1		NSP	
R464	C-CARBON R	RN72K1J-182JE	1		NSP	
R467	C-CARBON R	RN72K1J-182JE	1		NSP	
R470	C-CARBON R	RN72K1J-182JE	1		NSP	<B CMDC>
R471	C-CARBON R	RN72K1J-182JE	1		NSP	<B CMDC>
R472	C-CARBON R	RN72K1J-182JE	1		NSP	
R473	C-CARBON R	RN72K1J-182JE	1		NSP	
R474	C-CARBON R	RN72K1J-182JE	1		NSP	
R477	C-CARBON R	RN72K1J-182JE	1		NSP	
R480	C-CARBON R	RN72K1J-273JE	1		NSP	<B CMDC>
R481	C-CARBON R	RN72K1J-273JE	1		NSP	<B CMDC>
R482	C-CARBON R	RN72K1J-223JE	1		NSP	<B CMDC>
R483	C-CARBON R	RN72K1J-223JE	1		NSP	<B CMDC>
R484	C-CARBON R	RN72K1J-103JE	1		NSP	<B CMDC>
R485	C-CARBON R	RN72K1J-103JE	1		NSP	<B CMDC>
R486	C-CARBON R	RN72K1J-103JE	1		NSP	<B CMDC>
R487	C-CARBON R	RN72K1J-103JE	1		NSP	<B CMDC>
R490	C-CARBON R	RN72K1J-102JE	1		NSP	<B CMDC>
R491	C-CARBON R	RN72K1J-102JE	1		NSP	<B CMDC>
R498	C-CARBON R	RN72K1J-100JE	1		NSP	
R499	C-CARBON R	RN72K1J-100JE	1		NSP	
R501	C-CARBON R	RN72K1J-473JE	1		NSP	
R503	C-CARBON R	RN72K1J-103JE	1		NSP	
R504	C-CARBON R	RN72K1J-000JE	1		NSP	
R505	C-CARBON R	RN72K1J-103JE	1		NSP	
R506	C-CARBON R	RN72K1J-221JE	1		NSP	

R508	C-CARBON R	RN72K1J-105JE	1		NSP	
R509	C-CARBON R	RN72K1J-221JE	1		NSP	
R510	C-CARBON R	RN72K1J-470JE	1		NSP	
R511	C-CARBON R	RN72K1J-473JE	1		NSP	
R512	C-CARBON R	RN72K1J-221JE	1		NSP	
R514	C-CARBON R	RN72K1J-470JE	1		NSP	
R515	C-CARBON R	RN72K1J-470JE	1		NSP	
R516	C-CARBON R	RN72K1J-470JE	1		NSP	
R517	C-CARBON R	RN72K1J-470JE	1		NSP	
R518	C-CARBON R	RN72K1J-103JE	1		NSP	
R519	C-CARBON R	RN72K1J-470JE	1		NSP	
R520	C-CARBON R	RN72K1J-103JE	1		NSP	
R521	C-CARBON R	RN72K1J-470JE	1		NSP	
R522	C-CARBON R	RN72K1J-470JE	1		NSP	
R523	C-CARBON R	RN72K1J-470JE	1		NSP	
R527	C-CARBON R	RN72K1J-470JE	1		NSP	
R529	C-CARBON R	RN72K1J-470JE	1		NSP	
R530	C-CARBON R	RN72K1J-470JE	1		NSP	
R531	C-CARBON R	RN72K1J-103JE	1		NSP	
R532	C-CARBON R	RN72K1J-472JE	1		NSP	
R533	C-CARBON R	RN72K1J-472JE	1		NSP	
R534	C-CARBON R	RN72K1J-223JE	1		NSP	
R535	C-CARBON R	RN72K1J-223JE	1		NSP	
R536	C-CARBON R	RN72K1J-223JE	1		NSP	
R537	C-CARBON R	RN72K1J-223JE	1		NSP	
R538	C-CARBON R	RN72K1J-103JE	1		NSP	
R539	C-CARBON R	RN72K1J-470JE	1		NSP	<B CMDC>
R540	C-CARBON R	RN72K1J-470JE	1		NSP	<B CMDC>
R541	C-CARBON R	RN72K1J-470JE	1		NSP	<B CMDC>
R542	C-CARBON R	RN72K1J-470JE	1		NSP	<B CMDC>
R543	C-CARBON R	RN72K1J-103JE	1		NSP	
R544	C-CARBON R	RN72K1J-221JE	1		NSP	
R545	C-CARBON R	RN72K1J-221JE	1		NSP	
R546	C-CARBON R	RN72K1J-221JE	1		NSP	
R547	C-CARBON R	RN72K1J-221JE	1		NSP	
R548	C-CARBON R	RN72K1J-221JE	1		NSP	
R550	C-CARBON R	RN72K1J-470JE	1		NSP	
R551	C-CARBON R	RN72K1J-103JE	1		NSP	
R552	C-CARBON R	RN72K1J-103JE	1		NSP	
R553	C-CARBON R	RN72K1J-470JE	1		NSP	
R554	C-CARBON R	RN72K1J-103JE	1		NSP	
R556	C-CARBON R	RN72K1J-470JE	1		NSP	
R557	C-CARBON R	RN72K1J-103JE	1		NSP	

R558	C-CARBON R	RN72K1J-470JE	1		NSP
R559	C-CARBON R	RN72K1J-272JE	1		NSP
R562	C-CARBON R	RN72K1J-103JE	1		NSP
R563	C-CARBON R	RN72K1J-103JE	1		NSP
R565	C-CARBON R	RN72K1J-470JE	1		NSP <B CMDC>
R566	C-CARBON R	RN72K1J-222JE	1		NSP <B CMDC>
R567	C-CARBON R	RN72K1J-470JE	1		NSP <B CMDC>
R568	C-CARBON R	RN72K1J-222JE	1		NSP <B CMDC>
R569	C-CARBON R	RN72K1J-102JE	1		NSP <B CMDC>
R570	C-CARBON R	RN72K1J-273JE	1		NSP <B CMDC>
R571	C-CARBON R	RN72K1J-102JE	1		NSP <B CMDC>
R572	C-CARBON R	RN72K1J-273JE	1		NSP <B CMDC>
R573	C-CARBON R	RN72K1J-221JE	1		NSP
R574	C-CARBON R	RN72K1J-470JE	1		NSP
R575	C-CARBON R	RN72K1J-470JE	1		NSP
R576	C-CARBON R	RN72K1J-470JE	1		NSP
R578	C-CARBON R	RN72K1J-470JE	1		NSP
R579	C-CARBON R	RN72K1J-470JE	1		NSP
R580	C-CARBON R	RN72K1J-103JE	1		NSP
R581	C-CARBON R	RN72K1J-103JE	1		NSP
R582	C-CARBON R	RN72K1J-221JE	1		NSP
R583	C-CARBON R	RN72K1J-221JE	1		NSP
R584	C-CARBON R	RN72K1J-103JE	1		NSP
R585	C-CARBON R	RN72K1J-221JE	1		NSP
R586	C-CARBON R	RN72K1J-103JE	1		NSP
R587	C-CARBON R	RN72K1J-221JE	1		NSP
R588	C-CARBON R	RN72K1J-103JE	1		NSP
R589	C-CARBON R	RN72K1J-470JE	1		NSP
R590	C-CARBON R	RN72K1J-103JE	1		NSP
R591	C-CARBON R	RN72K1J-470JE	1		NSP
R592	C-CARBON R	RN72K1J-470JE	1		NSP
R593	C-CARBON R	RN72K1J-221JE	1		NSP
R594	C-CARBON R	RN72K1J-221JE	1		NSP
R595	C-CARBON R	RN72K1J-221JE	1		NSP
R596	C-CARBON R	RN72K1J-103JE	1		NSP
R597	C-CARBON R	RN72K1J-470JE	1		NSP
R598	C-CARBON R	RN72K1J-221JE	1		NSP
R599	C-CARBON R	RN72K1J-103JE	1		NSP
R600	C-CARBON R	RN72K1J-103JE	1		NSP
R601	C-CARBON R	RN72K1J-470JE	1		NSP
R602	C-CARBON R	RN72K1J-470JE	1		NSP
R603	C-CARBON R	RN72K1J-470JE	1		NSP
R604	C-CARBON R	RN72K1J-103JE	1		NSP

R605	C-CARBON R	RN72K1J-221JE	1		NSP
R606	C-CARBON R	RN72K1J-470JE	1		NSP
R607	C-CARBON R	RN72K1J-470JE	1		NSP
R608	C-CARBON R	RN72K1J-470JE	1		NSP
R609	C-CARBON R	RN72K1J-102JE	1		NSP
R611	C-CARBON R	RN72K1J-102JE	1		NSP
R613	C-CARBON R	RN72K1J-102JE	1		NSP
R614	C-CARBON R	RN72K1J-103JE	1		NSP
R615	C-CARBON R	RN72K1J-101JE	1		NSP <B CMDC>
R616	C-CARBON R	RN72K1J-103JE	1		NSP
R617	C-CARBON R	RN72K1J-221JE	1		NSP
R618	C-CARBON R	RN72K1J-103JE	1		NSP
R619	C-CARBON R	RN72K1J-470JE	1		NSP
R620	C-CARBON R	RN72K1J-103JE	1		NSP
R621	C-CARBON R	RN72K1J-221JE	1		NSP
R622	C-CARBON R	RN72K1J-470JE	1		NSP
R623	C-CARBON R	RN72K1J-103JE	1		NSP
R625	C-CARBON R	RN72K1J-470JE	1		NSP
R626	C-CARBON R	RN72K1J-103JE	1		NSP
R627	C-CARBON R	RN72K1J-000JE	1		NSP
R628	C-CARBON R	RN72K1J-221JE	1		NSP
R629	C-CARBON R	RN72K1J-221JE	1		NSP
R630	C-CARBON R	RN72K1J-221JE	1		NSP
R631	C-CARBON R	RN72K1J-470JE	1		NSP
R632	C-CARBON R	RN72K1J-470JE	1		NSP
R633	C-CARBON R	RN72K1J-103JE	1		NSP <B CMDC>
R634	C-CARBON R	RN72K1J-470JE	1		NSP
R635	C-CARBON R	RN72K1J-103JE	1		NSP <B CMDC>
R636	C-CARBON R	RN72K1J-470JE	1		NSP
R638	C-CARBON R	RN72K1J-470JE	1		NSP
R639	C-CARBON R	RN72K1J-103JE	1		NSP
R640	C-CARBON R	RN72K1J-470JE	1		NSP
R641	C-CARBON R	RN72K1J-103JE	1		NSP
R642	C-CARBON R	RN72K1J-221JE	1		NSP
R643	C-CARBON R	RN72K1J-103JE	1		NSP
R644	C-CARBON R	RN72K1J-221JE	1		NSP
R645	C-CARBON R	RN72K1J-103JE	1		NSP
R646	C-CARBON R	RN72K1J-221JE	1		NSP
R647	C-CARBON R	RN72K1J-103JE	1		NSP
R648	C-CARBON R	RN72K1J-221JE	1		NSP
R650	C-CARBON R	RN72K1J-221JE	1		NSP
R651	C-CARBON R	RN72K1J-103JE	1		NSP
R652	C-CARBON R	RN72K1J-102JE	1		NSP



R653	C-CARBON R	RN72K1J-105JE	1		NSP
R654	C-CARBON R	RN72K1J-103JE	1		NSP
R655	C-CARBON R	RN72K1J-221JE	1		NSP
R656	C-CARBON R	RN72K1J-221JE	1		NSP
R658	C-CARBON R	RN72K1J-221JE	1		NSP
R659	C-CARBON R	RN72K1J-273JE	1		NSP
R660	C-CARBON R	RN72K1J-221JE	1		NSP
R661	C-CARBON R	RN72K1J-221JE	1		NSP
R662	C-CARBON R	RN72K1J-000JE	1		NSP <B CMDC>
R664	C-CARBON R	RN72K1J-103JE	1		NSP <B CMDC>
R665	C-CARBON R	RN72K1J-333JE	1		NSP <B CMDC>
R667	C-CARBON R	RN72K1J-103JE	1		NSP <B CMDC>
R668	C-CARBON R	RN72K1J-103JE	1		NSP <B CMDC>
R669	C-CARBON R	RN72K1J-333JE	1		NSP <B CMDC>
R670	C-CARBON R	RN72K1J-472JE	1		NSP
R671	C-CARBON R	RN72K1J-272JE	1		NSP
R672	C-CARBON R	RN72K1J-472JE	1		NSP
R673	C-CARBON R	RN72K1J-272JE	1		NSP
R674	C-CARBON R	RN72K1J-472JE	1		NSP
R675	C-CARBON R	RN72K1J-272JE	1		NSP
R676	C-CARBON R	RN72K1J-472JE	1		NSP
R677	C-CARBON R	RN72K1J-272JE	1		NSP
R681	C-CARBON R	RN72K1J-473JE	1		NSP
R682	C-CARBON R	RN72K1J-103JE	1		NSP
R683	C-CARBON R	RN72K1J-103JE	1		NSP
R684	C-CARBON R	RN72K1J-000JE	1		NSP <B CMDC>
R685	C-CARBON R	RN72K1J-000JE	1		NSP <B CMDC>
R686	C-CARBON R	RN72K1J-103JE	1		NSP
R687	C-CARBON R	RN72K1J-103JE	1		NSP
R688	C-CARBON R	RN72K1J-103JE	1		NSP
R691	C-CARBON R	RN72K1J-103JE	1		NSP
R693	C-CARBON R	RN72K1J-103JE	1		NSP
R694	C-CARBON R	RN72K1J-221JE	1		NSP
R695	C-CARBON R	RN72K1J-221JE	1		NSP
R696	C-CARBON R	RN72K1J-470JE	1		NSP
R697	C-CARBON R	RN72K1J-470JE	1		NSP
R698	C-CARBON R	RN72K1J-103JE	1		NSP <B CMDC>
R701	C-CARBON R	RN72K1J-000JE	1		NSP
R706	C-CARBON R	RN72K1J-000JE	1		NSP <B CMDC>
R708	C-CARBON R	RN72K1J-103JE	1		NSP
R709	C-CARBON R	RN72K1J-103JE	1		NSP
R712	C-CARBON R	RN72K1J-102JE	1		NSP
R713	C-CARBON R	RN72K1J-222JE	1		NSP

R714	C-CARBON R	RN72K1J-103JE	1		NSP	
R715	C-CARBON R	RN72K1J-103JE	1		NSP	
R716	C-CARBON R	RN72K1J-470JE	1		NSP	
R721	C-CARBON R	RN72K1J-103JE	1		NSP	
R723	C-CARBON R	RN72K1J-101JE	1		NSP	
R724	C-CARBON R	RN72K1J-101JE	1		NSP	
R725	C-CARBON R	RN72K1J-221JE	1		NSP	
R726	C-CARBON R	RN72K1J-273JE	1		NSP	
R801	C-CARBON R	RN72K1J-000JE	1		NSP	
R807	C-CARBON R	RN72K1J-000JE	1		NSP	<B CMDC>
R811	C-CARBON R	RN72K1J-000JE	1		NSP	<B CMDC>
R813	C-CARBON R	RN72K1J-000JE	1		NSP	<B CMDC>
R823	C-CARBON R	RN72K1J-000JE	1		NSP	<B CMDC>
R824	C-CARBON R	RN72K1J-000JE	1		NSP	<B CMDC>
<b>[SW TRM]</b>						
JL501B	WIRE TRAP	NPLG-3P586	1	25055624		
JL502B	WIRE TRAP	NPLG-5P588	1	25055626		
JL901B	WIRE TRAP	NPLG-5P588	1	25055626		
P101A	SOCKET	NSCT-11P2104	1	25052207		<B CMDC>
P131	PIN JACK	NPJ-1PD0554	1	25045772		<B CMDC>
P2001A	SOCKET	IMSA-9142S-24A	1	25053234		
P2002B	SOCKET	NSCT-15P2195	1	25052298		
P2081	SOCKET	NNA1-01-006	1	25053357		
P5501A	SOCKET	NSCT-7P2187	1	25052290		
P5502A	SOCKET	NSCT-15P2195	1	25052298		
P5503A	SOCKET	NSCT-9P2189	1	25052292		
P5504A	SOCKET	NSCT-7P2187	1	25052290		<B CMDC>
P701A	SOCKET	NSCT-31P2124	1	25052227		
P751A	SOCKET	IMSA-9618S-09A	1	25053334R2		
P8001A	PLUG	IMSA-9111B-16	1	25056620		
P8002A	PLUG	IMSA-9111B-24	1	25056625		
<b>[TUNER UNIT]</b>						
U131	PHT CP	JSR1165-001recieving	1	24120143		
U132	PHT CP	JSR1165-001recieving	1	24120143		

## HT-R280

### PC BOARD PARTS LIST

<b>U004</b>	DIS-AS(Display Assy) U0040+U0041+U0042+U0043+U0044	BADIS-0373-1C *	1	1B247573-1C		or 380c
<b>U0040</b>	DIS-AS(Display Assy)	BADIS-0373-1C	1	1B2475373-1C		
<b>U0041</b>	PWB(STANDBY key/LED)	BADIS-0374-1C	1	Included in "REF.NO. U004	N	
<b>U0042</b>	PWB(Video Assy)	BAVD-0375-1C	1	1B2475375-1C	N	
<b>U0043</b>	PWB(Power Sippy)	BAETC-0376-1C	1	1B2475376-1C	N	

U0044	PWB(HP-Jack)	BAETC-0377-1C	1	1B2475377-1C	N
-------	--------------	---------------	---	--------------	---

CIRCUIT	PART NAME	DESCRIPTION	Q'TY	PART NO. (SN)	REMARKS
<b>[SEMI CONDUCTOR]</b>					
D7002	ZENER D	UDZS8.2B	1	224550820R2	
D7033	ZENER D	UDZS3.9B	1	224550390R2	
D7151	LED	SLI-343URC-TE7	1	225449T	
D7152	LED	SLI-343Y8C-TE7	1	225490T	N
D9011	DIODE	D5SBA20	1	22380130F	<B CMDC>
D9014	C-DIODE	KDS4148U	1		NSP
D9014 or	C-DIODE	1SS352	(1)		NSP
D9014 or	C-DIODE	MA2J111	(1)		NSP
D9015	C-DIODE	KDS4148U	1		NSP
D9015 or	C-DIODE	1SS352	(1)		NSP
D9015 or	C-DIODE	MA2J111	(1)		NSP
D9016	ZENER D	UDZS6.2B	1	224550620R2	<B CMDC>
D9023	C-DIODE	KDS4148U	1		NSP
D9023 or	C-DIODE	1SS352	(1)		NSP
D9023 or	C-DIODE	MA2J111	(1)		NSP
D9025	C-DIODE	KDS4148U	1		NSP
D9025 or	C-DIODE	1SS352	(1)		NSP
D9025 or	C-DIODE	MA2J111	(1)		NSP
D9032	C-DIODE	KDS4148U	1		NSP
D9032 or	C-DIODE	1SS352	(1)		NSP
D9032 or	C-DIODE	MA2J111	(1)		NSP
D911	C-DIODE	KDS4148U	1		NSP
D911 or	C-DIODE	1SS352	(1)		NSP
D911 or	C-DIODE	MA2J111	(1)		NSP
D912	C-DIODE	KDS4148U	1		NSP
D912 or	C-DIODE	1SS352	(1)		NSP
D912 or	C-DIODE	MA2J111	(1)		NSP
D921	C-DIODE	KDS4148U	1		NSP
D921 or	C-DIODE	1SS352	(1)		NSP
D921 or	C-DIODE	MA2J111	(1)		NSP
D922	C-DIODE	KDS4148U	1		NSP
D922 or	C-DIODE	1SS352	(1)		NSP
D922 or	C-DIODE	MA2J111	(1)		NSP
D923	C-DIODE	KDS4148U	1		NSP
D923 or	C-DIODE	1SS352	(1)		NSP
D923 or	C-DIODE	MA2J111	(1)		NSP
D924	C-DIODE	KDS4148U	1		NSP
D924 or	C-DIODE	1SS352	(1)		NSP
D924 or	C-DIODE	MA2J111	(1)		NSP
D925	C-DIODE	KDS4148U	1		NSP

D925 or	C-DIODE	1SS352	(1)		NSP	
D925 or	C-DIODE	MA2J111	(1)		NSP	
D930	C-DIODE	KDS4148U	1		NSP	
D930 or	C-DIODE	1SS352	(1)		NSP	
D930 or	C-DIODE	MA2J111	(1)		NSP	
D931	C-DIODE	KDS4148U	1		NSP	
D931 or	C-DIODE	1SS352	(1)		NSP	
D931 or	C-DIODE	MA2J111	(1)		NSP	
D933	C-DIODE	KDS4148U	1		NSP	
D933 or	C-DIODE	1SS352	(1)		NSP	
D933 or	C-DIODE	MA2J111	(1)		NSP	
D934	ZENER D	UDZS5.1B	1	224550510R2		<B CMDC>
D935	C-DIODE	KDS4148U	1		NSP	
D935 or	C-DIODE	1SS352	(1)		NSP	
D935 or	C-DIODE	MA2J111	(1)		NSP	
Q2001	IC	NJW1326FH2	1	22242583R3		
Q2002	IC	NJM2505AF	1	22242490R2		<B CMDC>
Q2002 or	IC	BH7673G-TR	(1)	22242661R2		<B CMDC>
Q7002	FL TUBE	16-BT-162GNK	1	212273		
Q7002A	HOLDER	(FL)	1	27191222C		
Q7003	IC	M66005-0001AHP	1	22242208R3		
Q7004	TR	KTC3875-GR	1	2216175R2		
Q7033	TR	KTC3875-GR	1	2216175R2		
Q9022	IC	78M05(NJM78M05FA)	1	222780055JRC		
Q9022 or	IC	78M05AHF(MPC78M05AHF)	(1)	222780055NEC		
Q9022A	SCREW	3P+6FN(3BC)	1		NSP	
Q9022B	HEAT SINK	RAD-157	1		NSP	
Q9031	IC	MPC2905BHF	1	22278005DBNE		
Q9031A	SCREW	3P+10FN(3BC)	1		NSP	
Q9031B	HEAT SINK	RAD-140	1		NSP	
<b>[TRANS COIL]</b>						
L7031	CHOKE COIL	LBC2518T2R2M	1	231364M022R2		
L7032	CHOKE COIL	LBC2518T2R2M	1	231364M022R2		
L7201	CHOKE COIL	LBC2518T2R2M	1	231364M022R2		
L7202	CHOKE COIL	LBC2518T2R2M	1	231364M022R2		
L7203	CHOKE COIL	LBC2518T2R2M	1	231364M022R2		
T902	P TRANS	NPT-1520JQ	1	2301812A	!	<B CMDC>
<b>[CAPACITOR]</b>						
C2001	VR C	CE04W50V-10M(VR)	1	394681007T		<B CMDC>
C2002	C-CERA C	CK725F1E-104Z1	1		NSP	<B CMDC>
C2003	VR C	CE04W6.3V-470M(VR)	1	394624717T		<B CMDC>
C2004	C-CERA C	CC725CH1H-470J1	1		NSP	<B CMDC>
C2005	VR C	CE04W6.3V-470M(VR)	1	394624717T		<B CMDC>

C2006	C-CERA C	CC725CH1H-470J1	1		NSP	<B CMDC>
C2011	C-CERA C	CK725F1A-105Z1	1		NSP	
C2012	C-CERA C	CK725F1A-105Z1	1		NSP	
C2013	C-CERA C	CK725F1A-105Z1	1		NSP	
C2014	C-CERA C	CK725F1A-105Z1	1		NSP	
C2015	C-CERA C	CK725F1A-105Z1	1		NSP	
C2016	C-CERA C	CK725F1A-105Z1	1		NSP	
C2017	C-CERA C	CK725F1A-105Z1	1		NSP	
C2018	C-CERA C	CK725F1A-105Z1	1		NSP	
C2019	C-CERA C	CK725F1A-105Z1	1		NSP	
C2020	C-CERA C	CK725F1A-105Z1	1		NSP	
C2021	C-CERA C	CK725F1A-105Z1	1		NSP	
C2022	C-CERA C	CK725F1A-105Z1	1		NSP	
C2025	C-CERA C	CK725F1A-105Z1	1		NSP	<B CMDC>
C2102	VR C	CE04W6.3V-470M(VR)	1	394624717T		
C2103	VR C	CE04W50V-10M(VR)	1	394681007T		
C2104	VR C	CE04W50V-10M(VR)	1	394681007T		
C2105	VR C	CE04W6.3V-470M(VR)	1	394624717T		
C2106	VR C	CE04W50V-10M(VR)	1	394681007T		
C2107	VR C	CE04W50V-10M(VR)	1	394681007T		
C2108	VR C	CE04W6.3V-470M(VR)	1	394624717T		
C2109	VR C	CE04W6.3V-470M(VR)	1	394624717T		
C2110	VR C	CE04W6.3V-470M(VR)	1	394624717T		
C2111	VR C	CE04W50V-1M(VR)	1	394680107T		
C2112	VR C	CE04W50V-1M(VR)	1	394680107T		
C2113	VR C	CE04W50V-1M(VR)	1	394680107T		
C2114	VR C	CE04W50V-1M(VR)	1	394680107T		
C2115	VR C	CE04W50V-1M(VR)	1	394680107T		
C2116	VR C	CE04W50V-1M(VR)	1	394680107T		
C2201	C-CERA C	CK725B1H-102K1	1		NSP	
C2202	C-CERA C	CK725B1H-102K1	1		NSP	
C2203	C-CERA C	CK725B1H-103K1	1		NSP	
C7001	C-CERA C	CK725B1H-223K1	1		NSP	
C7002	C-CERA C	CK725F1E-104Z1	1		NSP	
C7003	C-CERA C	CC725CH1H-101J1	1		NSP	
C7004	C-CERA C	CC725CH1H-101J1	1		NSP	
C7005	C-CERA C	CC725CH1H-101J1	1		NSP	
C7007	C-CERA C	CC725CH1H-101J1	1		NSP	
C7008	ELECT C	CE04W6.3V-100M	1	355721019T		
C7009	C-CERA C	CK725F1E-104Z1	1		NSP	
C7010	C-CERA C	CK725B1H-223K1	1		NSP	
C7011	C-CERA C	CK725B1H-223K1	1		NSP	
C7012	C-CERA C	CK725B1H-223K1	1		NSP	

C7013	ELECT C	CE04W50V-33M	1	355783309T	
C7014	C-CERA C	CK725B1H-223K1	1		NSP
C7015	ELECT C	CE04W16V-47M(S)	1	353744709T	
C7016	C-CERA C	CK725B1H-223K1	1		NSP
C7017	C-CERA C	CK725B1H-223K1	1		NSP
C7021	C-CERA C	CK725B1H-103K1	1		NSP
C7022	C-CERA C	CK725B1H-103K1	1		NSP
C7031	C-CERA C	CK725B1H-223K1	1		NSP
C7032	C-CERA C	CK725B1H-223K1	1		NSP
C7033	ELECT C	CE04W16V-10M(S)	1	353741009T	
C7041	ELECT C	CE04W6.3V-100M(S)	1	353721019T	
C7042	C-CERA C	CC725CH1H-102J1	1		NSP
C7043	C-CERA C	CC725CH1H-102J1	1		NSP
C7201	C-CERA C	CC725CH1H-102J1	1		NSP
C7202	C-CERA C	CK725B1H-223K1	1		NSP <B CMDC>
C7203	MKT C	B32529C0102J289	1	376491024T	<B CMDC>
C7204	MKT C	B32529C0102J289	1	376491024T	<B CMDC>
C7301	C-CERA C	CC725CH1H-471J1	1		NSP
C7302	C-CERA C	CC725CH1H-471J1	1		NSP
C7303	C-CERA C	CK725F1E-104Z1	1		NSP
C7305	C-CERA C	CK725F1E-104Z1	1		NSP
C901	IS C	LE103-C3.5	1	3800042S	
C901 or	IS C	ECQU2A103MLC	(1)	3800039S	
C9011	VR C	CE04W16V-10000M(VR)	1	394641037S	
C9012	TF C	ECQ-V50V-334J	1	374723344T	
C9013	VR C	CE04W50V-4.7M(VR)	1	394680477T	
C902	C-CERA C	CK725F1E-104Z1	1		NSP
C9023	VR C	CE04W50V-10M(VR)	1	394681007T	
C9025	VR C	CE04W6.3V-470M(VR)	1	394624717T	
C9026	VR C	CE04W6.3V-470M(VR)	1	394624717T	
C9027	C-CERA C	CK725F1E-104Z1	1		NSP
C9028	VR C	CE04W6.3V-470M(VR)	1	394624717T	
C9029	C-CERA C	CK725F1E-104Z1	1		NSP
C9030	VR C	CE04W25V-220M(VR)	1	394652217T	
C9031	C-CERA C	CK725F1E-104Z1	1		NSP
C9032	VR C	CE04W6.3V-470M(VR)	1	394624717T	
C911	C-CERA C	CC725CH1H-102J1	1		NSP <B CMDC>
C921	C-CERA C	CK725B1H-223K1	1		NSP
C922	VR C	CE04W25V-2200M(VR)	1	394652227S	
C930	UTSP C	CE04W50V-100M(UTSP)	1	397581017T	
C933	UTSP C	CE04W50V-4.7M(UTSP)	1	397580477T	
<b>[RESISTOR]</b>					
R2001	C-CARBON R	RN72K1J-220JE	1		NSP <B CMDC>

R2002	C-CARBON R	RN72K1J-220JE	1		NSP	<B CMDC>
R2003	C-CARBON R	RN72K1J-105JE	1		NSP	<B CMDC>
R2102	C-CARBON R	RN72K1J-750JE	1		NSP	
R2103	C-CARBON R	RN72K1J-750JE	1		NSP	
R2104	C-CARBON R	RN72K1J-750JE	1		NSP	
R2105	C-CARBON R	RN72K1J-750JE	1		NSP	
R2106	C-CARBON R	RN72K1J-750JE	1		NSP	
R2107	C-CARBON R	RN72K1J-750JE	1		NSP	
R2108	C-CARBON R	RN72K1J-750JE	1		NSP	
R2109	C-CARBON R	RN72K1J-750JE	1		NSP	
R2110	C-CARBON R	RN72K1J-750JE	1		NSP	
R2111	C-CARBON R	RN72K1J-750JE	1		NSP	
R2112	C-CARBON R	RN72K1J-750JE	1		NSP	
R2113	C-CARBON R	RN72K1J-750JE	1		NSP	
R2114	C-CARBON R	RN72K1J-750JE	1		NSP	
R2115	C-CARBON R	RN72K1J-750JE	1		NSP	
R2116	C-CARBON R	RN72K1J-750JE	1		NSP	
R2155	C-CARBON R	RN72K1J-000JE	1		NSP	
R2156	C-CARBON R	RN72K1J-000JE	1		NSP	
R2157	C-CARBON R	RN72K1J-000JE	1		NSP	
R7001	C-CARBON R	RN72K1J-103JE	1		NSP	
R7002	C-CARBON R	RN72K1J-332JE	1		NSP	
R7003	C-CARBON R	RN72K1J-332JE	1		NSP	
R7004	C-CARBON R	RN72K1J-221JE	1		NSP	
R7005	C-CARBON R	RN72K1J-221JE	1		NSP	
R7006	C-CARBON R	RN72K1J-103JE	1		NSP	
R7007	C-CARBON R	RN72K1J-221JE	1		NSP	
R7008	C-CARBON R	RN72K1J-221JE	1		NSP	
R7021	C-CARBON R	RN72K1J-103JE	1		NSP	
R7022	C-CARBON R	RN72K1J-103JE	1		NSP	
R7023	C-CARBON R	RN72K1J-103JE	1		NSP	
R7024	C-CARBON R	RN72K1J-103JE	1		NSP	
R7033	C-CARBON R	RN72K1J-820JE	1		NSP	
R7041	C-CARBON R	RN72K1J-101JE	1		NSP	
R7042	C-CARBON R	RN72K1J-102JE	1		NSP	
R7101	C-CARBON R	RN72K1J-271JE	1		NSP	
R7102	C-CARBON R	RN72K1J-331JE	1		NSP	
R7103	C-CARBON R	RN72K1J-471JE	1		NSP	
R7106	C-CARBON R	RN72K1J-271JE	1		NSP	<B CMDC>
R7107	C-CARBON R	RN72K1J-331JE	1		NSP	<B CMDC>
R7108	C-CARBON R	RN72K1J-471JE	1		NSP	<B CMDC>
R7109	C-CARBON R	RN72K1J-561JE	1		NSP	<B CMDC>
R7110	C-CARBON R	RN72K1J-821JE	1		NSP	<B CMDC>

R7111	C-CARBON R	RN72K1J-122JE	1		NSP
R7112	C-CARBON R	RN72K1J-222JE	1		NSP
R7113	C-CARBON R	RN72K1J-392JE	1		NSP
R7114	C-CARBON R	RN72K1J-123JE	1		NSP
R7115	C-CARBON R	RN72K1J-271JE	1		NSP
R7116	C-CARBON R	RN72K1J-331JE	1		NSP
R7117	C-CARBON R	RN72K1J-471JE	1		NSP
R7118	C-CARBON R	RN72K1J-561JE	1		NSP
R7119	C-CARBON R	RN72K1J-821JE	1		NSP
R7120	C-CARBON R	RN72K1J-122JE	1		NSP
R7121	C-CARBON R	RN72K1J-222JE	1		NSP
R7122	C-CARBON R	RN72K1J-392JE	1		NSP
R7123	C-CARBON R	RN72K1J-271JE	1		NSP
R7124	C-CARBON R	RN72K1J-331JE	1		NSP
R7125	C-CARBON R	RN72K1J-471JE	1		NSP
R7126	C-CARBON R	RN72K1J-561JE	1		NSP
R7127	C-CARBON R	RN72K1J-821JE	1		NSP
R7128	C-CARBON R	RN72K1J-122JE	1		NSP
R7129	C-CARBON R	RN72K1J-222JE	1		NSP
R7130	C-CARBON R	RN72K1J-000JE	1		NSP <B CMDC>
R7151	C-CARBON R	RN72K1J-222JE	1		NSP
R7152	C-CARBON R	RN72K1J-222JE	1		NSP
R7301	C-CARBON R	RN72K1J-331JE	1		NSP
R7302	C-CARBON R	RN72K1J-331JE	1		NSP
R7304	C-CARBON R	RN72K1J-000JE	1		NSP <B CMDC>
R9012	METAL R	RNU1/2WCJ-1	1	453530104T	
R9013	METAL R	RNU1/2WCJ-1	1	453530104T	
R9014	C-CARBON R	RN72K1J-104JE	1		NSP
R9020	METAL O R	RS1WBJ-8.2	1	441620824F	
R9021	METAL O R	RS1WBJ-8.2	1	441620824F	
R9022	METAL R	RNU1/2WCJ-1	1	453530104T	
R9031	METAL R	RNU2WCJ-3.3	1	452730334F	
R9032	METAL R	RNU2WCJ-3.3	1	452730334F	
R9033	METAL R	RNU1/2WCJ-1	1	453530104T	
R921	METAL O R	RS1/2WBJ-47	1	443524704T	
R934	C-CARBON R	RN72K1J-104JE	1		NSP
<b>[SW TRM]</b>					
E7201	TRM-423(SCREW)	NEJITANSI ST3	1	25060495	<B CMDC>
E7301A	RETAINER	(EARTH)	1	27142136B	<B CMDC>
E9001	TRM-423(SCREW)	NEJITANSI ST3	1	25060495	
E9003	TRM-423(SCREW)	NEJITANSI ST3	1	25060495	
E901	TRM-423(SCREW)	NEJITANSI ST3	1	25060495	
E902	TRM-423(SCREW)	NEJITANSI ST3	1	25060495	



F901C	FUSE HOL	NSCT-1P2031	1	25052133T	<B CMDC>
F901D	FUSE HOL	NSCT-1P2031	1	25052133T	<B CMDC>
F901E	LABEL	LABEL	1	29360842	<B CMDC>
JL605A	WIRE HOL	NSCT-5P896	1	25051109	
JL702A	WIRE HOL	NSCT-9P880	1	25051093	
JL702B	WIRE HOL	NSCT-9P880	1	25051093	
JL801A	WIRE HOL	NSCT-5P876	1	25051089	
JL901A	WIRE HOL	NSCT-5P876	1	25051089	
JL952B	SOCKET	NSCT-3P95	1	25050267	
JL953A	WIRE HOL	NSCT-5P876	1	25051089	
P2001B	PLUG	IMSA-9142B-24A	1	25056602	
P2002A	PLUG	NPLG-15P0970	1	25056020	<B CMDC>
P2201	PIN JACK	NPJ-3PDYYY560	1	25045778	
P2202	PIN JACK	NPJ-3PDYYY560	1	25045778	
P2203	PIN JACK	NPJ-9PDGLRGLRGLR563	1	25045781	
P2203 or	PIN JACK	NPJ-9PDGLR519	(1)	25045731	
P701B	SOCKET	NSCT-31P2161	1	25052264	
P7201	ST JACK	MSJ-064-05A SR	1	25045783	
P7201 or	ST JACK	YKB21-5005	(1)	25045724	
P7311	ST JACK	MSJ-035-05A BAG SR LF	1	25045927	<B CMDC>
P901A	PLUG	NPLG-2P631	1	25055675	
P901A or	PLUG	1-1123724-2	(1)	25056402	
P911	PLUG	NPLG-2P631	1	25055675	
P911 or	PLUG	1-1123724-2	(1)	25056402	
RL901	RELAY	NRL-1P5A-DC9-179	1	25065669	<B CMDC>
S7002	R ENCODE	EC12E2425WITH WASHER	1	25065655W	
S7102	PUSH SW	NPS-111-S681	1	25035718T	
S7104	PUSH SW	NPS-111-S681	1	25035718T	<B CMDC>
S7106	PUSH SW	NPS-111-S681	1	25035718T	
S7108	PUSH SW	NPS-111-S681	1	25035718T	
S7113	PUSH SW	NPS-111-S681	1	25035718T	<B CMDC>
S7115	PUSH SW	NPS-111-S681	1	25035718T	<B CMDC>
S7117	PUSH SW	NPS-111-S681	1	25035718T	<B CMDC>
S7119	PUSH SW	NPS-111-S681	1	25035718T	<B CMDC>
S7123	PUSH SW	NPS-111-S681	1	25035718T	<B CMDC>
S7125	PUSH SW	NPS-111-S681	1	25035718T	<B CMDC>
S7127	PUSH SW	NPS-111-S681	1	25035718T	<B CMDC>
S7129	PUSH SW	NPS-111-S681	1	25035718T	<B CMDC>
S7132	PUSH SW	NPS-111-S681	1	25035718T	
S7134	PUSH SW	NPS-111-S681	1	25035718T	
S7136	PUSH SW	NPS-111-S681	1	25035718T	
S7138	PUSH SW	NPS-111-S681	1	25035718T	
S7140	PUSH SW	NPS-111-S681	1	25035718T	

S7142	PUSH SW	NPS-111-S681	1	25035718T		
S7144	PUSH SW	NPS-111-S681	1	25035718T		
S7146	PUSH SW	NPS-111-S681	1	25035718T		
S7148	PUSH SW	NPS-111-S681	1	25035718T		
S7150	PUSH SW	NPS-111-S681	1	25035718T		
S7152	PUSH SW	NPS-111-S681	1	25035718T		
S7154	PUSH SW	NPS-111-S681	1	25035718T		
S7156	PUSH SW	NPS-111-S681	1	25035718T		
S7158	PUSH SW	NPS-111-S681	1	25035718T		
S7160	PUSH SW	NPS-111-S681	1	25035718T		
S7162	PUSH SW	NPS-111-S681	1	25035718T		
S7164	PUSH SW	NPS-111-S681	1	25035718T		

**[TUNER UNIT]**

U7041	REMO SENS	KSM-603TE5B	1	24130019		
-------	-----------	-------------	---	----------	--	--

**HT-R280**

**PC BOARD PARTS LIST**

<b>U007</b>	HDM-AS(HDMI Assy)	BAHDM-0401-1A *	1	1B247501-1A		or 308c
-------------	-------------------	-----------------	---	-------------	--	---------

CIRCUIT	PART NAME	DESCRIPTION	Q'TY	PART NO. (SN)	REMARKS
<b>[SEMI CONDUCTOR]</b>					
D8100	C-DIODE	KDS4148U	1		NSP
D8100 or	C-DIODE	1SS352	(1)		NSP
D8100 or	C-DIODE	1SS355	(1)		NSP
D8100 or	C-DIODE	MA2J111	(1)		NSP
D8951	DIODE	XBS303V17R	1	22380365R2	
D8971	DIODE	XBS303V17R	1	22380365R2	
Q201	IC	D788E001BRFP266Z	1	22242502R3	
Q203	IC	TC7WU04FU(TE12L_F)	1	22240935R2	
Q203 or	IC	TC7WZU04FU(TE12L_F)	(1)	22242078R2TO	
Q271	IC	XC6220B121PR	1	22242626R2	N
Q281	IC	K4S641632N-LC60	1	22242603R2	
Q281 or	IC	EM638165TS-7G	(1)	22242607R2	
Q282	IC (DSP Flash memory)	ES29LV160ET70TG IC(0372	1	222W0069R303726	
Q282 or	IC (DSP Flash memory)	S29AL016J70TFI010 IC(037	(1)	222W0100R303726	
Q282 or	IC (DSP Flash memory)	ES29LV160FT-70T IC(03726	(1)	222W0101R303726	
Q282 or	IC (DSP Flash memory)	MX29LV160DTTI-7(03726) IC	(1)	222W0104R303726	
Q8101	IC	ADV7623	1	22242625R3	N
Q8104	IC	S-812C50BUC-C5ET2G	1	22242407R2	
Q8105	IC (OSD Flash memory)	EN25Q32A-100HIP IC(03788	1	222W0112R203785	
Q8111	TR	RN1401(TE85L_F)	1	2214460R2	
Q8111 or	TR	KRC101S	(1)	2216330R2	
Q8112	TR	RN1401(TE85L_F)	1	2214460R2	

Q8112 or	TR	KRC101S	(1)	2216330R2	
Q8113	TR	RN1401(TE85L_F)	1	2214460R2	
Q8113 or	TR	KRC101S	(1)	2216330R2	
Q8114	TR	RN1401(TE85L_F)	1	2214460R2	
Q8114 or	TR	KRC101S	(1)	2216330R2	
Q8115	TR	RN1401(TE85L_F)	1	2214460R2	
Q8115 or	TR	KRC101S	(1)	2216330R2	
Q8116	TR	RN1401(TE85L_F)	1	2214460R2	
Q8116 or	TR	KRC101S	(1)	2216330R2	
Q8951	IC	MP2363DN-LF-Z	1	22242627R2	N
Q8971	IC	MP2363DN-LF-Z	1	22242627R2	N
Q8972	IC	XC6221B182MR	1	22242632R2	
<b>[TRANS COIL]</b>					
L203	C-CARBON R	RN72K1J-000JE	1		NSP
L204	EMIFIL	BK1608LM182-T	1	230958R1	
L206	EMIFIL	BK1608LM182-T	1	230958R1	
L261	CORE	BLM18PG181SN1D	1	2350005R1	
L262	CORE	NFM18PC105R0J3D	1	2350014R1	N
L263	CORE	BLM18PG181SN1D	1	2350005R1	
L271	CORE	BLM18PG181SN1D	1	2350005R1	
L281	CORE	BLM18PG181SN1D	1	2350005R1	
L8101	EMIFIL	BK1608LM182-T	1	230958R1	
L8102	C-R NET	MNR12E0APJ000	1	43464900002R2	
L8103	C-R NET	MNR12E0APJ000	1	43464900002R2	
L8104	C-R NET	MNR12E0APJ000	1	43464900002R2	
L8105	C-R NET	MNR12E0APJ000	1	43464900002R2	
L8911	CORE	BLM18PG181SN1D	1	2350005R1	
L8912	CORE	BLM18PG181SN1D	1	2350005R1	
L8931	CORE	BLM18PG181SN1D	1	2350005R1	
L8932	CORE	BLM18PG181SN1D	1	2350005R1	
L8933	CORE	BLM18PG181SN1D	1	2350005R1	
L8937	CORE	BLM18PG181SN1D	1	2350005R1	
L8938	CORE	BLM18PG181SN1D	1	2350005R1	
L8939	CORE	BLM18PG181SN1D	1	2350005R1	
L8951	CHOKE COIL	0182-7E08Q-100M-RA	1	231396M100R2	
L8952	CORE	BLM18PG181SN1D	1	2350005R1	
L8953	CORE	BLM18PG181SN1D	1	2350005R1	
L8971	CHOKE COIL	0182-7E08Q-100M-RA	1	231396M100R2	
L8972	CORE	BLM18PG181SN1D	1	2350005R1	
L8973	CORE	BLM18PG181SN1D	1	2350005R1	
L8974	CORE	BLM18PG181SN1D	1	2350005R1	
X201	CRYSTAL	HC-49USSMD17.734MHz	1	3010488R2	
X8100	CRYSTAL	HC-49USSMD28.6363MHz	1	3010491R2	N

**[CAPACITOR]**

C201	C-CERA C	CK725F1E-104Z1	1		NSP
C202	C-CERA C	CK725F1E-104Z1	1		NSP
C203	C-CERA C	CK725F1E-104Z1	1		NSP
C204	C-CERA C	CK725F1E-104Z1	1		NSP
C205	C-CERA C	CK725F1E-104Z1	1		NSP
C206	C-CERA C	CK725F1E-104Z1	1		NSP
C207	C-CERA C	CK725F1E-104Z1	1		NSP
C208	C-CERA C	CK725F1E-104Z1	1		NSP
C209	C-CERA C	CK725F1E-104Z1	1		NSP
C210	C-CERA C	CK725F1E-104Z1	1		NSP
C211	C-CERA C	CK725F1E-104Z1	1		NSP
C212	C-CERA C	CK725F1E-104Z1	1		NSP
C213	C-CERA C	CK725F1E-104Z1	1		NSP
C214	C-CERA C	CK725F1E-104Z1	1		NSP
C215	C-CERA C	CK725F1E-104Z1	1		NSP
C216	C-CERA C	CK725F1E-104Z1	1		NSP
C221	C-CERA C	CK725F1E-104Z1	1		NSP
C222	C-CERA C	CK725F1E-104Z1	1		NSP
C223	C-CERA C	CK725F1E-104Z1	1		NSP
C224	C-CERA C	CK725F1E-104Z1	1		NSP
C225	C-CERA C	CK725F1E-104Z1	1		NSP
C226	C-CERA C	CK725F1E-104Z1	1		NSP
C227	C-CERA C	CK725F1E-104Z1	1		NSP
C228	C-CERA C	CK725F1E-104Z1	1		NSP
C229	C-CERA C	CK725F1E-104Z1	1		NSP
C230	C-CERA C	CK725F1E-104Z1	1		NSP
C231	C-CERA C	CK725F1E-104Z1	1		NSP
C232	C-CERA C	CK725F1E-104Z1	1		NSP
C233	C-CERA C	CK725F1E-104Z1	1		NSP
C236	C-CERA C	CC725CH1H-101J1	1		NSP
C238	C-CERA C	CC725CH1H-100D1	1		NSP
C239	C-CERA C	CC725CH1H-100D1	1		NSP
C240	C-CERA C	CC725CH1H-100D1	1		NSP
C242	C-CERA C	CK725F1E-104Z1	1		NSP
C243	C-CERA C	CK725B1H-102K1	1		NSP
C244	C-CERA C	CK725F1E-104Z1	1		NSP
C261	C-CERA C	CK725B0J-106K	1		NSP
C262	C-CERA C	CK725B0J-106K	1		NSP
C271	C-CERA C	CK725B0J-106K	1		NSP
C272	C-CERA C	CK725B0J-106K	1		NSP
C273	C-CERA C	CK725B0J-106K	1		NSP
C274	C-CERA C	CK725B0J-106K	1		NSP

C275	C-CERA C	CK725BOJ-106K	1		NSP
C282	C-CERA C	CK725BOJ-106K	1		NSP
C283	C-CERA C	CK725F1E-104Z1	1		NSP
C284	C-CERA C	CK725F1E-104Z1	1		NSP
C285	C-CERA C	CK725F1E-104Z1	1		NSP
C286	C-CERA C	CK725F1E-104Z1	1		NSP
C287	C-CERA C	CK725F1E-104Z1	1		NSP
C288	C-CERA C	CK725F1E-104Z1	1		NSP
C289	C-CERA C	CK725F1E-104Z1	1		NSP
C290	C-CERA C	CK725F1E-104Z1	1		NSP
C291	C-CERA C	CK725F1E-104Z1	1		NSP
C292	C-CERA C	CK725B1H-102K1	1		NSP
C293	C-CERA C	CK725B1H-102K1	1		NSP
C294	C-CERA C	CK725B1H-102K1	1		NSP
C295	C-CERA C	CK725B1H-102K1	1		NSP
C296	C-CERA C	CK725B1H-102K1	1		NSP
C8103	C-CERA C	CK725F1E-104Z1	1		NSP
C8104	C-CERA C	CK725B1H-102K1	1		NSP
C8105	C-CERA C	CK725F1E-104Z1	1		NSP
C8106	C-CERA C	CK725B1H-102K1	1		NSP
C8107	C-CERA C	CK725F1E-104Z1	1		NSP
C8108	C-CERA C	CK725B1H-102K1	1		NSP
C8109	C-CERA C	CK725F1E-104Z1	1		NSP
C8110	C-CERA C	CK725B1H-102K1	1		NSP
C8111	C-CERA C	CK725F1E-104Z1	1		NSP
C8112	C-CERA C	CK725B1H-102K1	1		NSP
C8113	C-CERA C	CK725F1E-104Z1	1		NSP
C8114	C-CERA C	CK725B1H-102K1	1		NSP
C8115	C-CERA C	CK725F1E-104Z1	1		NSP
C8116	C-CERA C	CK725B1H-102K1	1		NSP
C8118	C-CERA C	CK725B1H-102K1	1		NSP
C8119	C-CERA C	CK725F1E-104Z1	1		NSP
C8120	C-CERA C	CK725B1H-102K1	1		NSP
C8121	C-CERA C	CK725F1E-104Z1	1		NSP
C8122	C-CERA C	CK725F1E-104Z1	1		NSP
C8123	C-CERA C	CC725CH1H-070D1	1		NSP
C8124	C-CERA C	CK725B1H-102K1	1		NSP
C8125	C-CERA C	CK725B1H-102K1	1		NSP
C8126	C-CERA C	CK725F1E-104Z1	1		NSP
C8127	C-CERA C	CC725CH1H-070D1	1		NSP
C8128	C-CERA C	CK725B1H-102K1	1		NSP
C8129	C-CERA C	CK725F1E-104Z1	1		NSP
C8130	C-CERA C	CK725B1H-102K1	1		NSP

C8131	C-CERA C	CK725B1H-102K1	1		NSP
C8132	C-CERA C	CK725B1H-102K1	1		NSP
C8133	C-CERA C	CK725F1E-104Z1	1		NSP
C8134	C-CERA C	CK725B1H-102K1	1		NSP
C8135	C-CERA C	CK725F1E-104Z1	1		NSP
C8136	C-CERA C	CK725B1H-102K1	1		NSP
C8137	C-CERA C	CK725F1E-104Z1	1		NSP
C8138	C-CERA C	CK725B1H-102K1	1		NSP
C8139	C-CERA C	CK725B1H-102K1	1		NSP
C8140	C-CERA C	CK725F1E-104Z1	1		NSP
C8141	C-CERA C	CK725B1H-102K1	1		NSP
C8142	C-CERA C	CK725F1E-104Z1	1		NSP
C8143	C-CERA C	CK725B1H-102K1	1		NSP
C8144	C-CERA C	CK725B1H-102K1	1		NSP
C8145	C-CERA C	CK725B1H-102K1	1		NSP
C8146	C-CERA C	CK725F1E-104Z1	1		NSP
C8147	C-CERA C	CK725B1H-102K1	1		NSP
C8148	C-CERA C	CK725F1E-104Z1	1		NSP
C8149	C-CERA C	CK725B1H-102K1	1		NSP
C8151	C-CERA C	CK725F1E-104Z1	1		NSP
C8152	C-CERA C	CK725B1H-102K1	1		NSP
C8153	C-CERA C	CK725F1E-104Z1	1		NSP
C8154	C-CERA C	CK725B1H-102K1	1		NSP
C8155	C-CERA C	CK725F1E-104Z1	1		NSP
C8156	C-CERA C	CK725B1H-102K1	1		NSP
C8158	C-CERA C	CK725F1E-104Z1	1		NSP
C8159	C-CERA C	CK725B1H-102K1	1		NSP
C8160	C-CERA C	CK725F1E-104Z1	1		NSP
C8161	C-CERA C	CK725B1H-102K1	1		NSP
C8162	C-CERA C	CK725F1E-104Z1	1		NSP
C8163	C-CERA C	CK725B1H-102K1	1		NSP
C8164	C-CERA C	CK725F1E-104Z1	1		NSP
C8165	C-CERA C	CK725B1H-102K1	1		NSP
C8166	C-CERA C	CK725B1H-102K1	1		NSP
C8168	C-CERA C	CK725B1H-102K1	1		NSP
C8169	C-CERA C	CK725B1H-102K1	1		NSP
C8170	C-CERA C	CK725F1E-104Z1	1		NSP
C8172	C-CERA C	CK725B0J-106K	1		NSP
C8173	C-CERA C	CK725F1E-104Z1	1		NSP
C8175	C-CERA C	CK725B1H-102K1	1		NSP
C8176	C-CERA C	CK725F1A-105Z1	1		NSP
C8177	C-CERA C	CK725F1A-105Z1	1		NSP
C8911	C-CERA C	CK725B0J-106K	1		NSP

C8912	C-CERA C	CK725F1A-105Z1	1		NSP
C8931	C-CERA C	CK725B0J-106K	1		NSP
C8932	C-CERA C	CK725B0J-106K	1		NSP
C8933	C-CERA C	CK725F1A-105Z1	1		NSP
C8934	C-CERA C	CK725F1A-105Z1	1		NSP
C8935	C-CERA C	CK725F1A-105Z1	1		NSP
C8936	C-CERA C	CK725F1A-105Z1	1		NSP
C8950	CHIP ELECT C	CEWX16V-100M	1	398141017R2	
C8951	C-CERA C	CK725B1E-106K	1		N NSP
C8952	C-CERA C	CK725B1E-106K	1		N NSP
C8953	C-CERA C	CK725B0J-106K	1		NSP
C8954	C-CERA C	CK725B0J-106K	1		NSP
C8955	C-CERA C	CK725B0J-106K	1		NSP
C8956	CHIP ELECT C	CEWX16V-100M	1	398141017R2	
C8957	C-CERA C	CK725F1E-104Z1	1		NSP
C8958	C-CERA C	CK725B1H-223K1	1		NSP
C8959	C-CERA C	CK725F1E-104Z1	1		NSP
C8960	C-CERA C	CK725B1H-103K1	1		NSP
C8963	C-CERA C	CC725CH1H-151J1	1		NSP
C8971	C-CERA C	CK725B1E-106K	1		N NSP
C8972	C-CERA C	CK725B1E-106K	1		N NSP
C8973	C-CERA C	CK725B0J-106K	1		NSP
C8974	C-CERA C	CK725B0J-106K	1		NSP
C8975	C-CERA C	CK725B0J-106K	1		NSP
C8976	CHIP ELECT C	CEWX16V-100M	1	398141017R2	
C8977	C-CERA C	CK725F1E-104Z1	1		NSP
C8978	C-CERA C	CK725B1H-223K1	1		NSP
C8979	C-CERA C	CK725F1A-105Z1	1		NSP
C8980	C-CERA C	CK725B1H-682K1	1		NSP
C8983	C-CERA C	CK725F1A-105Z1	1		NSP
C8984	C-CERA C	CK725F1A-105Z1	1		NSP
C8985	C-CERA C	CK725F1A-105Z1	1		NSP
C8991	C-CERA C	CK725F1E-104Z1	1		NSP
C8992	C-CERA C	CK725F1E-104Z1	1		NSP
<b>[RESISTOR]</b>					
R200	C-CARBON R	RN72K1J-221JE	1		NSP
R201	C-CARBON R	RN72K1J-103JE	1		NSP
R202	C-CARBON R	RN72K1J-103JE	1		NSP
R203	C-CARBON R	RN72K1J-103JE	1		NSP
R205	C-CARBON R	RN72K1J-103JE	1		NSP
R206	C-CARBON R	RN72K1J-221JE	1		NSP
R207	C-CARBON R	RN72K1J-221JE	1		NSP
R208	C-CARBON R	RN72K1J-103JE	1		NSP

R209	C-CARBON R	RN72K1J-470JE	1		NSP
R210	C-R NET	RM7LJ330X04	1	43484733004R2	
R211	C-R NET	RM7LJ330X04	1	43484733004R2	
R212	C-R NET	RM7LJ330X04	1	43484733004R2	
R213	C-R NET	RM7LJ330X04	1	43484733004R2	
R214	C-R NET	RM7LJ330X04	1	43484733004R2	
R215	C-R NET	RM7LJ330X04	1	43484733004R2	
R216	C-R NET	RM7LJ330X04	1	43484733004R2	
R217	C-R NET	RM7LJ330X04	1	43484733004R2	
R218	C-R NET	RM7LJ330X04	1	43484733004R2	
R221	C-CARBON R	RN72K1J-750JE	1		NSP
R240	C-CARBON R	RN72K1J-331JE	1		NSP
R241	C-CARBON R	RN72K1J-331JE	1		NSP
R242	C-CARBON R	RN72K1J-470JE	1		NSP
R243	C-CARBON R	RN72K1J-221JE	1		NSP
R244	C-CARBON R	RN72K1J-470JE	1		NSP
R245	C-CARBON R	RN72K1J-103JE	1		NSP
R246	C-CARBON R	RN72K1J-000JE	1		NSP
R250	C-CARBON R	RN72K1J-472JE	1		NSP
R251	C-CARBON R	RN72K1J-221JE	1		NSP
R252	C-CARBON R	RN72K1J-331JE	1		NSP
R253	C-CARBON R	RN72K1J-470JE	1		NSP
R254	C-CARBON R	RN72K1J-470JE	1		NSP
R255	C-CARBON R	RN72K1J-470JE	1		NSP
R256	C-CARBON R	RN72K1J-470JE	1		NSP
R257	C-CARBON R	RN72K1J-470JE	1		NSP
R258	C-CARBON R	RN72K1J-470JE	1		NSP
R259	C-CARBON R	RN72K1J-331JE	1		NSP
R260	C-CARBON R	RN72K1J-470JE	1		NSP
R261	C-CARBON R	RN72K1J-470JE	1		NSP
R262	C-CARBON R	RN72K1J-331JE	1		NSP
R263	C-CARBON R	RN72K1J-331JE	1		NSP
R264	C-CARBON R	RN72K1J-331JE	1		NSP
R265	C-CARBON R	RN72K1J-470JE	1		NSP
R267	C-CARBON R	RN72K1J-105JE	1		NSP
R281	C-CARBON R	RN72K1J-103JE	1		NSP
R282	C-CARBON R	RN72K1J-103JE	1		NSP
R283	C-CARBON R	RN72K1J-103JE	1		NSP
R284	C-CARBON R	RN72K1J-103JE	1		NSP
R285	C-CARBON R	RN72K1J-103JE	1		NSP
R286	C-CARBON R	RN72K1J-331JE	1		NSP
R287	C-CARBON R	RN72K1J-103JE	1		NSP
R288	C-CARBON R	RN72K1J-103JE	1		NSP



R289	C-CARBON R	RN72K1J-472JE	1		NSP
R290	C-CARBON R	RN72K1J-472JE	1		NSP
R8118	C-CARBON R	RN72K1J-102JE	1		NSP
R8119	C-CARBON R	RN72K1J-102JE	1		NSP
R8120	C-CARBON R	RN72K1J-000JE	1		NSP
R8121	C-CARBON R	RN72K1J-102JE	1		NSP
R8122	C-CARBON R	RN72K1J-473JE	1		NSP
R8124	C-CARBON R	RN72K1J-103JE	1		NSP
R8125	C-CARBON R	RN72K1J-101JE	1		NSP
R8126	C-CARBON R	RN72K1J-101JE	1		NSP
R8127	C-CARBON R	RN72K1J-330JE	1		NSP
R8128	C-CARBON R	RN72K1J-331JE	1		NSP
R8129	C-CARBON R	RN72K1J-330JE	1		NSP
R8130	C-CARBON R	RN72K1J-103JE	1		NSP
R8131	C-R NET	RM7LJ330X04	1	43484733004R2	
R8132	C-CARBON R	RN72K1J-101JE	1		NSP
R8133	C-CARBON R	RN72K1J-103JE	1		NSP
R8134	C-CARBON R	RN72K1J-101JE	1		NSP
R8135	C-CARBON R	RN72K1J-101JE	1		NSP
R8136	C-CARBON R	RN72K1J-102JE	1		NSP
R8137	C-CARBON R	RN72K1J-101JE	1		NSP
R8138	C-CARBON R	RN72K1J-000JE	1		NSP
R8139	C-CARBON R	RN72K1J-103JE	1		NSP
R8140	C-CARBON R	RN72K1J-473JE	1		NSP
R8142	C-CARBON R	RN72K1J-220JE	1		NSP
R8144	C-CARBON R	RN72K1J-472JE	1		NSP
R8145	C-CARBON R	RN72K1J-472JE	1		NSP
R8146	C-CARBON R	RN72K1J-103JE	1		NSP
R8148	C-CARBON R	RN72K1J-473JE	1		NSP
R8150	C-CARBON R	RN72K1J-470JE	1		NSP
R8151	C-CARBON R	RN72K1J-470JE	1		NSP
R8152	C-CARBON R	RN72K1J-470JE	1		NSP
R8153	C-CARBON R	RN72K1J-470JE	1		NSP
R8154	C-CARBON R	RN72K1J-220JE	1		NSP
R8155	C-CARBON R	RN72K1J-220JE	1		NSP
R8156	C-CARBON R	RN72K1J-220JE	1		NSP
R8158	C-CARBON R	RN72K1J-473JE	1		NSP
R8159	C-CARBON R	RN72K1J-182JE	1		NSP
R8160	C-CARBON R	RN72K1J-182JE	1		NSP
R8161	C-CARBON R	RN72K1J-821FE	1		NSP
R8162	C-CARBON R	RN72K1J-680JE	1		NSP
R8164	C-CARBON R	RN72K1J-473JE	1		NSP
R8165	C-CARBON R	RN72K2E-470JE	1		NSP

R8166	C-CARBON R	RN72K1J-102JE	1		NSP
R8167	C-CARBON R	RN72K1J-000JE	1		NSP
R8169	C-CARBON R	RN72K1J-473JE	1		NSP
R8172	C-CARBON R	RN72K1J-103JE	1		NSP
R8177	C-CARBON R	RN72K1J-101JE	1		NSP
R8178	C-CARBON R	RN72K1J-101JE	1		NSP
R8179	C-CARBON R	RN72K1J-101JE	1		NSP
R8180	C-CARBON R	RN72K1J-101JE	1		NSP
R8181	C-CARBON R	RN72K1J-100JE	1		NSP
R8182	C-CARBON R	RN72K1J-100JE	1		NSP
R8191	C-CARBON R	RN72K1J-103JE	1		NSP
R8192	C-CARBON R	RN72K1J-103JE	1		NSP
R8193	C-CARBON R	RN72K1J-103JE	1		NSP
R8953	C-CARBON R	RN72K1J-273FE	1		NSP
R8955	C-CARBON R	RN72K1J-103FE	1		NSP
R8956	C-CARBON R	RN72K1J-562JE	1		NSP
R8971	C-CARBON R	RN72K1J-102JE	1		NSP
R8973	C-CARBON R	RN72K1J-103FE	1		NSP
R8975	C-CARBON R	RN72K1J-103FE	1		NSP
R8976	C-CARBON R	RN72K1J-332JE	1		NSP
R8991	C-CARBON R	RN72K1J-220JE	1		NSP
R8992	C-CARBON R	RN72K1J-220JE	1		NSP
<b>[SW TRM]</b>					
JL801B	WIRE TRAP	NPLG-5P588	1	25055626	
P8001B	SOCKET	IMSA-9111S-24L	1	25053259	
P8002B	SOCKET	IMSA-9111S-16L	1	25053258	
P8102	SOCKET	HDMI(47266-4101)	1	25053389R3	
P8102 or	SOCKET	YKF45-7037V	(1)	25053253R3	
P8103	SOCKET	HDMI(47266-4101)	1	25053389R3	
P8103 or	SOCKET	YKF45-7037V	(1)	25053253R3	
P8104	SOCKET	HDMI(47266-4101)	1	25053389R3	
P8104 or	SOCKET	YKF45-7037V	(1)	25053253R3	
P8105	SOCKET	HDMI(47266-4101)	1	25053389R3	
P8105 or	SOCKET	YKF45-7037V	(1)	25053253R3	
P8901	SOCKET	IMSA-9618S-08A	1	25053333R2	N

---

**ONKYO CORPORATION**

Service Dept. Technical Support : 2-1, Nisshin-cho, Neyagawa-shi, OSAKA 572-8540, JAPAN  
Tel: 072-831-8023 Fax: 072-831-8163

**ONKYO U.S.A. CORPORATION**

18 Park Way, Upper Saddle River, N.J. 07458, U.S.A.  
Tel: 800-229-1687, 201-785-2600 Fax: 201-785-2650 <http://www.us.onkyo.com/>

**ONKYO EUROPE ELECTRONICS GmbH**

Liegnitzerstrasse 6, 82194 Groebenzell, GERMANY  
Tel: +49-8142-4401-0 Fax: +49-8142-4401-555 <http://www.eu.onkyo.com/>

**ONKYO EUROPE ELECTRONICS GmbH (UK BRANCH)**

The Coach House 81A High Street, Marlow, Buckinghamshire, SL7 1AB, UK  
Tel: +44-(0)1628-473-350 Fax: +44-(0)1628-401-700

**ONKYO CHINA LIMITED**

Unit 1&12, 9/F, Ever Gain Plaza Tower 1, 88, Container Port Road, Kwai Chung,  
N.T., Hong Kong. Tel: 852-2429-3118 Fax: 852-2428-9039  
<http://www.ch.onkyo.com/>

