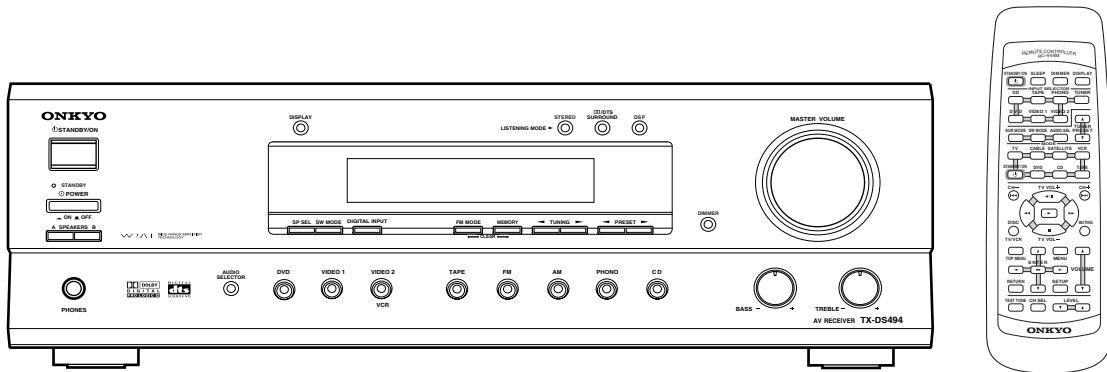

ONKYO® SERVICE MANUAL**AV RECEIVER****TX-DS494/HT-R490****TX-DS494**
Black, Silver and Golden model

BMDD	120V AC, 60Hz
BMPP, SMPP, BMPA, GMPA	230-240V AC, 50Hz
BMWT, BMWR, GMWT, GMWR	120/220-230V AC, 50/60Hz
GMGT	220-230V AC 50/60Hz

HT-R490
Black model
120V AC, 60Hz**SAFETY-RELATED COMPONENT WARNING!!**

COMPONENTS IDENTIFIED BY MARK \triangle ON THE SCHEMATIC DIAGRAM AND IN THE PARTS LIST ARE CRITICAL FOR RISK OF FIRE AND ELECTRIC SHOCK. REPLACE THESE COMPONENTS WITH ONKYO PARTS WHOSE PART NUMBERS APPEAR AS SHOWN IN THIS MANUAL.

MAKE LEAKAGE-CURRENT OR RESISTANCE MEASUREMENTS TO DETERMINE THAT EXPOSED PARTS ARE ACCEPTABLY INSULATED FROM THE SUPPLY CIRCUIT BEFORE RETURNING THE APPLIANCE TO THE CUSTOMER.

SEPECIFICATIONS

AMPLIFIER SECTION

Continuous Average Power output (FTC)

All channels: **55 watts per channel min. RMS at 8 ohms, 2 channels driven from 20 Hz to 20 kHz with no more than 0.08% total harmonic distortion.**
70 watts min. RMS at 6 ohms, 2 channels driven from 1 kHz with no more than 0.1% total harmonic distortion.

Continuous Power output (DIN) 75 watts 5 at 6 ohms
 Maximum Power output (EIAJ) 100 watts 5 at 6 ohms
 Total Harmonic Distortion: 0.08% at rated power (Front)
 IM Distortion: 0.08% at rated power (Front)
 Damping Factor: 60 at 8 ohms (Front)

Input Sensitivity and Impedance

* PHONO: 2.5 mV, 50 kohms

LINE (CD, TAPE, DVD, VIDEO 1, 2): 200 mV, 50 kohms

MULTICHANNEL INPUT

(FRONT L/R, SURROUND L/R,

CENTER): 200 mV, 50 kohms

(SUBWOOFER): 36 mV, 50 kohms

DIGITAL 2 (COAXIAL): 0.5 Vp-p, 75 ohms

Output Level and Impedance

Rec out (TAPE, VIDEO 2): 200 mV, 2.2 kohms

Pre out (SUBWOOFER): 1 V, 2.2 kohms

* Phono Overload: 110 mV RMS at 1 kHz, 0.5% T.H.D.

Frequency Response: 20 Hz to 100 kHz, +1/∓3 dB

RIAA Deviation: 20 Hz to 20 kHz, ±0.8 dB

Tone Control

Bass: ±10 dB at 50 Hz

Treble: ±10 dB at 10 kHz

Signal-to-Noise Ratio

Phono: 80 dB (IHF-A, 5 mV input)

CD/Tape: 100 dB (IHF-A)

VIDEO SECTION

Input Sensitivity and Impedance

VIDEO (DVD, VIDEO 1, 2): 1 Vp-p, 75 ohms

S VIDEO (DVD, VIDEO 1, *2): 1 Vp-p, 75 ohms (Y)
 0.28 Vp-p, 75 ohms (C)

Output Level and Impedance

VIDEO (VIDEO 2, MONITOR): 1 Vp-p, 75 ohms

S VIDEO (MONITOR): 1 Vp-p, 75 ohms (Y)
 0.28 Vp-p, 75 ohms (C)

TUNER SECTION

FM

Tuning Range: 87.5-108.0 MHz (50 kHz steps)

Usable Sensitivity

Mono: 11.2 dBf, 1.0 μV (75 ohms)

Stereo: 17.2 dBf, 2.0 μV (75 ohms)

50 dB Quieting Sensitivity

Mono: 17.2 dBf, 2.0 μV (75 ohms)

Stereo: 37.2 dBf, 2.0 μV (75 ohms)

[NOTES]

* : TX-DS494 only

Capture Ratio: 2.0 dB

Image Rejection Ratio

North American models: 40 dB

Other models: 85 dB

IF Rejection Ratio: 90 dB

Signal-to-Noise Ratio

Mono: 76 dB

Stereo: 70 dB

Alternate Channel Attenuation: 55 dB

Selectivity: 50 dB (DIN)

AM Suppression Ratio: 50 dB

Total Harmonic Distortion

Mono: 0.2%

Stereo: 0.3%

Frequency Response: 30 Hz-15 kHz, ±1.0 dB

Stereo Separation: 45 dB at 1 kHz

30 dB at 100 Hz-10 kHz

AM

Tuning Range

North American models: 530-1,710 kHz (10 kHz steps)

European & Australian models: 522-1,611 kHz (9 kHz steps)

Worldwide models: 531-1,602 kHz (9 kHz steps),

530-1,710 kHz (10 kHz steps)

Usable Sensitivity: 30 μV

Image Rejection Ratio: 40 dB

IF Rejection Ratio: 40 dB

Signal-to-Noise Ratio: 40 dB

Total Harmonic Distortion: 0.7%

GENERAL

Power Supply:

AC 120 V, 60 Hz

AC 230-240 V, 50 Hz

AC 220-230 V and 120 V switchable,
 50/60 Hz

Power Consumption:

3.4 A

260 W

Dimensions (W × H × D):

435 × 150 × 339 mm

17-1/8" 5-7/8" 13-3/8"

Weight

North American models: 9.7 kg, 21.4 lbs.

European & Australian models: 10.3 kg, 22.7 lbs.

Worldwide models: 10.9 kg, 24.0 lbs.

REMOTE CONTROL

Transmitter: Infrared

Signal range: Approx. 5 meters, 16 ft.

Power supply: Two "AA" batteries (1.5 V × 2)

Specifications and features are subject to change without notice.

Power supply and voltage vary depending on the area in which the unit is purchased.

SERVICE PROCEDURES

1. Replacing the fuses

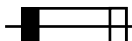
 This symbol located near the fuse indicates that the fuse used is slow operating type. For continued protection against fire hazard, replace with same type fuse. For fuse rating, refer to the marking adjacent to the symbol.

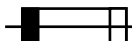
 Ce symbole indique que le fusible utilisé est lent. Pour une protection permanente, n'utiliser que des fusibles de même type. Ce dernier est indiqué la où le présent symbole est apposé.

REF. NO.	PART NO.	DESCRIPTION
F911	252166	△ 6.3A-UL/T-237, Fuse <DD,WT,WR,490>
F922	252077 or 252243	△ 4A-SE-EAK or 4A-SE-TL250V, Fuse <PP,WT,WR,GT,PA>
F923	252075	△ 2.5A-SE-EAK, Fuse <PP>

[NOTE] <DD> : 120V model only
 <DT> : Asian model only for 120V
 <GT> : Asian model only for 230V
 <PP> : European model only
 <WT> : World wide model only
 <WR> : Chinese model only
 <490> : HT-R490 only

2. To initialize the unit

This device employs a microprocessor to perform various functions and operations. If interference generated by an external power supply, radio wave, or other electrical source results in accident which causes the specified operations and functions to operate abnormally.

To perform a result, please follow the procedure below.

1. Press and hold down the VIDEO 1 button, then press the SPEAKER A button when the unit is Power ON.
2. After " CLEAR " is displayed, the preset memory and each mode stored in the memory, are initialized and will return to the factory settings.

3. Safety-check out

(Only U.S.A. model)

After correcting the original service problem perform the following safety check before releasing the set to the customer. Connect the insulating-resistance tester between the plug of power supply cord and terminal GND on the back panel. Specifications: More than 10Mohm at 500V

4. Memory Preservation

This unit does not require memory preservation batteries. A built-in memory power back-up system preserves the contents of the memory during power failures and even when the unit is unplugged. The unit must be plugged in order to charge the back-up system.

The memory preservation period after the unit has been unplugged varies depending on climate and placement of the unit. On the average, memory contents are protected over a period of a few weeks after the last time the unit has been unplugged. This period is shorter when the unit is exposed to a highly humid climate.

5. Setting the AM tuning step frequency (World wide models only)

Worldwide models are equipped with a switch that controls the AM band tuning step. Please set this switch to match the AM band tuning step frequency in your area.

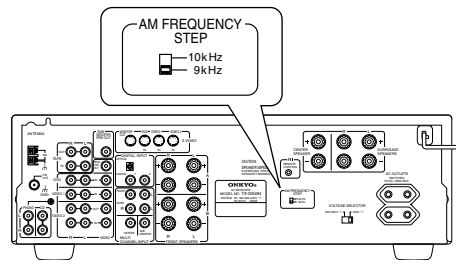

6. Setting the voltage selector (Worldwide models only)

Worldwide models are equipped with a voltage selector conform with local power supplies. Be sure to set this switch to match the voltage of the power supply in your area before plugging in the unit.

Determine the proper voltage for your area: 230V or 120V.

If the preset voltage is not correct for your area, insert a screwdriver into the groove in the switch. Slide the switch all the way to the right (120V) or to the left (220V-230V), whichever is appropriate.

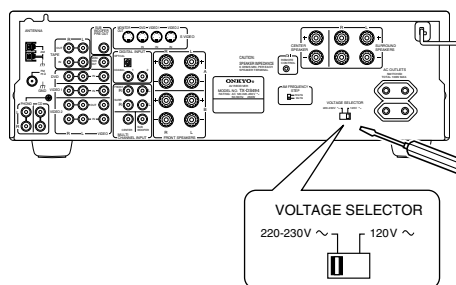

7. Changing the AM band step

With the exception of the worldwide models, a tuning step selector switch is not provided. When you change the band step, change the parts as shown below.

	To 10kHz	To 9kHz
R7020	Open	10k
R7021	10kohm	8.2kohm

NADIS-7043 (Display circuit PC board)

From soldering side

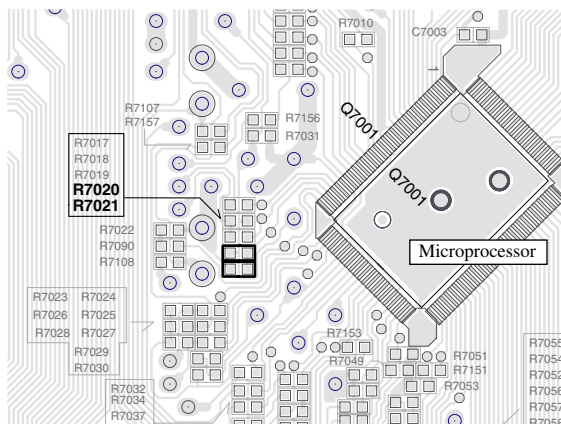

EXPLODED VIEW PARTS LIST-1

REF. NO.	PART NO.	DESCRIPTION	REF. NO.	PART NO.	DESCRIPTION
1	27111200	Front bracket 	45	27122810	Rear panel <DD>
	27111201	Front bracket <S>		27122811	Rear panel <PP>
	27111202	Front bracket <G>		27122813	Rear panel <WT>
2	27141787	Retainer, HP		27122814	Rear panel <WR>
3	838130088	3TTB+8B, Self tapping screw		27122815	Rear panel <PA>
4	82143010	3P+10FN(BC), Self tapping screw		27122812	Rear panel <GT>
6	27100368B	Chassis		27122824A	Rear panel <490>
7	27190266	KGLS-12RF, Holder	46	87643010	W3*10F(BC), Flat washer
8	27190428A	KGLS-10RF, Holder	47	838930088	3TTB+8B(UN), Self tapping screw
9	27190813	KGPS-10RF, Holder	48	27212285	Front panel <DD, WT, WR, PA>
12	830440089	4TTC+8C(BC), Self tapping screw		27212286	Front panel <PP>
14	27300750	△ Bushing, cord #2271 <DD,PP,WR,WT, PA,GT>		27212287	Front panel <S> <PP>
15	27160435	Heat sink L		27212288	Front panel <G> <PA, WR, WT, GT>
17	801433	3SMS8W.SW+14B(BC), Special screw		27212292	Front panel <490>
18	27141681	Retainer, PWB	49	28198778	Facet
20	27141735	Retainer, Rear	50	28135244	Badge
21	27141734	Retainer, Front		28135245	Badge <S,G>
24	27160436A	Heat sink S	D910	22380038 or	RBV602 or
25	82143010	3P+10FN(BC) Pan head screw		22380274	RS603M, Diode
26	29362772	Label, cover	E811	223024	Isolated sheet, AC238
27	27141729	Retainer, S	E891	880048	P-3055B-8L, Plastic rivet
28	838430068	3TTB+6B(BC), Self tapping screw	F911	252166	△ 6.3A-UL/T-237, Fuse <DD,WT,WR,490>
29	29110083	Tape, Cross-16U	F922	252077 or	△ 4A-SE-EAK or
32	27215357	Decorative frame 		252243	△ 4A-SE-TL250V, Fuse <PP,WT,WR,GT,PA>
	27215359	Decorative frame <S>		252075	△ 2.5A-SE-EAK, Fuse <PP>
	27215358	Decorative frame <G>	F923	252075	
33	28325497A	Knob, power 	P101	2047151512	NCFC7-151512, Flexible flat cable
	28325547A	Knob, power <S>	P7001	2047252012	NCFC7-252012, Flexible flat cable
	28325499A	Knob, power <G>	P702	2047202022	NCFC7-202022, Flexible flat cable
34	28191911	Clear plate 			
	28191912	Clear plate <S,G>			
36	28184663-1	Top cover 			
	28184666	Top cover <S>			
	28184682	Top cover <G>			
37	28141408	Cushion			
38	838430088	3TTB+8B(BC), Self tapping screw 			
	838930088	3TTB+8B(UN), Self tapping screw <S, G>			
39	27175319A	Leg			
40	28141332	Cushion, leg			
41	831430088	3TTW+8B(BC), Self tapping screw			
42	28325641	Knob, Volume 			
	28325642	Knob, Volume <S>			
	28325643	Knob, Volume <G>			
43	28325405	Knob, tone 			
	28325474	Knob, tone <S>			
	28325407	Knob, tone <G>			
44	27191130	Holder, outlet <WR>			

[NOTE]

<DD>: 120V model only
 <DT>: Asian model only for 120V
 <GT>: Asian model only for 230V
 <PP>: European model only
 <WT>: World wide model only
 <WR>: Chinese model only
 <494>: TX-DS494 only
 <490>: HT-R490 only
 : Black model only
 <S>: Silver model only
 <G>: Golden model only

NOTE: THE COMPONENTS IDENTIFIED BY MARK △ ARE CRITICAL FOR RISK OF FIRE AND ELECTRIC SHOCK. REPLACE ONLY WITH PART NUMBER SPECIFIED.

EXPLODED VIEW PARTS LIST-2

REF. NO.	PART NO.	DESCRIPTION	REF. NO.	PART NO.	DESCRIPTION		
P901	253279HIT	△ AS-UC-2#18 or	U1	1A865589-2A	NAAF-6789-2A, Front channel power amplifier PC board ass'y <DD>		
	253280VOL	△ AS-UC-2#18 <DD>		1A865589-2B	NAAF-6789-2B, Front channel power amplifier PC board ass'y <PP,PA, GT>		
	253306VOL or	△ AS CEE-2 or		1A865589-2C	NAAF-6789-2C, Front channel power amplifier PC board ass'y <490>		
	253193HIT	△ AS-CEE <PP, GT>		1A865589-2D	NAAF-6789-2D, Front channel power amplifier PC board ass'y <WT, WR>		
	253197HIT or	△ AS-SAA or		U2	1A865590-2A	NAAF-6790-2A, Surround channel power amplifier PC board ass'y <DD>	
	253307VOL	△ AS-SAA <PA>			1A865590-2B	NAAF-6790-2B, Surround channel power amplifier PC board ass'y <PP,PA, GT>	
	253233KAW or	△ AS-CEE-2 or		1A865590-2C	NAAF-6790-2C, Surround channel power amplifier PC board ass'y <490>		
	253306VOL	△ AS-CEE-2 <WT>		1A865590-2D	NAAF-6790-2D, Surround channel power amplifier PC board ass'y <WT, WR>		
	253267KAW,	△ AS-CCEE,		U3	1A865591-2A	NAETC-6791-2A, Front speaker terminal PC board ass'y <DD>	
	253285HIT or	△ AS-CCEE or			1A865591-2B	NAETC-6791-2B, Front speaker terminal PC board ass'y <PP,PA, GT>	
	253286VOL	△ AS-CCEE <WR>			1A865591-2C	NAETC-6791-2C, Front speaker terminal PC board ass'y <490>	
	Q523, Q524 , Q1512 Q623, Q624	2202253 or		* 2SC4467-O or	U4	1A865591-2D	NAETC-6791-2D, Front speaker terminal PC board ass'y <WT, WR>
		2202254 or		* 2SC4467-Y or		1A865592-2A	NAETC-6792-2A, Surround speaker terminal PC board ass'y <DD>
2202256 or		* 2SC4467-P or	1A865592-2B	NAETC-6792-2B, Surround speaker terminal PC board ass'y <PP,PA, GT>			
2203042 or		* 2SC5197-R or	1A865592-2C	NAETC-6792-2C, Surround speaker terminal PC board ass'y <490>			
2203043 or		* 2SC5197-O or	U5	1A865592-2D		NAETC-6792-2D, Surround speaker terminal PC board ass'y <WT, WR>	
2203502 or	* KTD718-R or	1A865594-2A		NAETC-6794-2A, Holder PC board ass'y <DD>			
Q525, Q526 , Q1513 Q625, Q626	2203503	* KTD718-O, Transistor	U6	1A865594-2B	NAETC-6794-2B, Holder PC board ass'y <PP,PA, GT>		
	2202243 or	* 2SA1694-O or		1A865594-2C	NAETC-6794-2C, Holder PC board ass'y <490>		
	2202244 or	* 2SA1694-Y or		1A865594-2D	NAETC-6794-2D, Holder PC board ass'y <WT, WR>		
	2202246 or	* 2SA1694-P or		U7	1A865595-2A	NAETC-6795-2A, Secondary terminal PC board ass'y <DD>	
	2203032 or	* 2SA1940-R or			1A865595-2B	NAETC-6795-2B, Secondary terminal PC board ass'y <PP,PA, GT>	
	2203033 or	* 2SA1940-O or		U8	1A865595-2C	NAETC-6795-2C, Secondary terminal PC board ass'y <490>	
	2203492 or	* KTB688-R or			1A865595-2D	NAETC-6795-2D, Secondary terminal PC board ass'y <WT, WR>	
	Q517, Q518	2203493		* KTB688-O, Transistor	U9	1A899543-1A	NADIS-7043-1A, Display circuit PC board ass'y <DD>
		2212654 or		* 2SC3421-Y or		1A899543-1B	NADIS-7043-1B, Display circuit PC board ass'y <PP>
		2212653		* 2SC3421-O, Transistor		1A899543-1C	NADIS-7043-1C, Display circuit PC board ass'y <PA,GT>
Q921	222780125	* 78M12HF, IC	U10	1A899543-1D	NADIS-7043-1D, Display circuit PC board ass'y <WT,WR>		
	Q922	222790125		1A899543-1F	NADIS-7043-1F, Display circuit PC board ass'y <490>		
Q933	222780055	* 78M05HF, IC	U8	1A899544-1A	NAAR-7044-1A, Main PC board ass'y <DD>		
T901	2301438	△ NPT-1384D, Power transformer <DD, 490>		1A899544-1B	NAAR-7044-1B, Main PC board ass'y <PP>		
	2301440	△ NPT-1384P, Power transformer <PP, PA>	1A899544-1C	NAAR-7044-1C, Main PC board ass'y <PA,GT>			
	2301441	△ NPT-1384DG, Power transformer <WT, WR, GT>	1A899544-1D	NAAR-7044-1D, Main PC board ass'y <WT,WR>			
			U9	1A899544-1F	NAAR-7044-1F, Main PC board ass'y <490>		
				1A899545-1A	NAETC-7045-1A, Head phone jack PC board ass'y <DD>		
			U10	1A899545-1B	NAETC-7045-1B, Head phone jack PC board ass'y <PP>		
				1A899545-1C	NAETC-7045-1C, Head phone jack PC board ass'y <PA,GT>		
			U10	1A899545-1D	NAETC-7045-1D, Head phone jack PC board ass'y <WT,WR>		
				1A899545-1F	NAETC-7045-1F, Head phone jack PC board ass'y <490>		
			U10	1A899546-1A	NAETC-7046-1A, Master volume PC board ass'y <DD>		
				1A899546-1B	NAETC-7046-1B, Master volume PC board ass'y <PP>		
			U10	1A899546-1C	NAETC-7046-1C, Master volume PC board ass'y <PA,GT>		
				1A899546-1D	NAETC-7046-1D, Master volume PC board ass'y <WT,WR>		
			U10	1A899546-1F	NAETC-7046-1F, Master volume PC board ass'y <490>		

CAUTION : Replacement of the transistor of mark *, if necessary, must be made from the same beta group(HFE) as the original type.

[NOTE]

<DD> : 120V model only
 <DT> : Asian model only for 120V
 <GT> : Asian model only for 230V
 <PP> : European model only
 <WT> : World wide model only
 <WR> : Chinese model only
 <494> : TX-DS494 only
 <490> : HT-R490 only

 : Black model only
 <S> : Silver model only
 <G> : Golden model only

NOTE: THE COMPONENTS IDENTIFIED BY MARK △ ARE CRITICAL FOR RISK OF FIRE AND ELECTRIC SHOCK. REPLACE ONLY WITH PART NUMBER SPECIFIED.

EXPLODED VIEW PARTS LIST-3

REF. NO.	PART NO.	DESCRIPTION	REF. NO.	PART NO.	DESCRIPTION
U11	1A899547-1A	NAETC-7047-1A, Tone control PC board ass'y <DD>	U20	1A899556-1A	NAETC-7056-1A, Video terminal PC board ass'y <DD>
	1A899547-1B	NAETC-7047-1B, Tone control PC board ass'y <PP>		1A899556-1B	NAETC-7056-1B, Video terminal PC board ass'y <PP>
	1A899547-1C	NAETC-7047-1C, Tone control PC board ass'y <PA,GT>		1A899556-1C	NAETC-7056-1C, Video terminal PC board ass'y <PA>
	1A899547-1D	NAETC-7047-1D, Tone control PC board ass'y <WT,WR>		1A899556-1D	NAETC-7056-1D, Video terminal PC board ass'y <WT>
	1A899547-1F	NAETC-7047-1F, Tone control PC board ass'y <490>		1A899556-1F	NAETC-7056-1F, Video terminal PC board ass'y <490>
U12	1A899548-1A	NAETC-7048-1A, Holder PC board ass'y <DD>	U21	1A899556-1G	NAETC-7056-1G, Video terminal PC board ass'y <GT>
	1A899548-1B	NAETC-7048-1B, Holder PC board ass'y <PP>		1A899556-1H	NAETC-7056-1H, Video terminal PC board ass'y <WR>
	1A899548-1C	NAETC-7048-1C, Holder PC board ass'y <PA,GT>		1A899557-1A	NAAF-7057-1A, Multi channel input terminal PC board ass'y <DD>
	1A899548-1D	NAETC-7048-1D, Holder PC board ass'y <WT,WR>		1A899557-1B	NAAF-7057-1B, Multi channel input terminal PC board ass'y <PP>
	1A899548-1F	NAETC-7048-1F, Holder PC board ass'y <490>		1A899557-1C	NAAF-7057-1C, Multi channel input terminal PC board ass'y <PA>
U13	1A899549-1A	NADG-7049-1A, DSP circuit PC board ass'y <DD>	U23	1A899557-1D	NAAF-7057-1D, Multi channel input terminal PC board ass'y <WT>
	1A899549-1B	NADG-7049-1B, DSP circuit PC board ass'y <PP, WR,WT, PA, GT>		1A899557-1F	NAAF-7057-1F, Multi channel input terminal PC board ass'y <490>
U14	1A899549-1C	NADG-7049-1C, DSP circuit PC board ass'y <490>	U23	1A899557-1G	NAAF-7057-1G, Multi channel input terminal PC board ass'y <GT>
	1A899550-1A	NAAF-7050-1A, Input terminal PC board ass'y <DD>		1A899557-1H	NAAF-7057-1H, Multi channel input terminal PC board ass'y <WR>
	1A899550-1B	NAAF-7050-1B, Input terminal PC board ass'y <PP>		240134 or	TFCE1U114A or
	1A899550-1C	NAAF-7050-1C, Input terminal PC board ass'y <PA>		240138A	ENG06501QR <DD, 490>
	1A899550-1D	NAAF-7050-1D, Input terminal PC board ass'y <WT>		240135 or	TFCE1E512A or
U15	1A899550-1F	NAAF-7050-1F, Input terminal PC board ass'y <490>	240139A	ENG07501Q <PP, WT, WR, PA, GT>	
	1A899550-1G	NAAF-7050-1G, Input terminal PC board ass'y <GT>			
	1A899550-1H	NAAF-7050-1H, Input terminal PC board ass'y <WR>			
	1A899551-1A	NAPS-7051-1A, Primary circuit PC board ass'y <DD>			
	1A899551-1B	NAPS-7051-1B, Primary circuit PC board ass'y <PP>			
U16	1A899551-1C	NAPS-7051-1C, Primary circuit PC board ass'y <PA>			
	1A899551-1D	NAPS-7051-1D, Primary circuit PC board ass'y <WT>			
	1A899551-1F	NAPS-7051-1F, Primary circuit PC board ass'y <490>			
	1A899551-1G	NAPS-7051-1G, Primary circuit PC board ass'y <GT>			
	1A899551-1H	NAPS-7051-1H, Primary circuit PC board ass'y <WR>			
U17	1A899552-1A	NASW-7052-1A, Power switch PC board ass'y <DD>			
	1A899552-1B	NASW-7052-1B, Power switch PC board ass'y <PP>			
	1A899552-1C	NASW-7052-1C, Power switch PC board ass'y <PA>			
	1A899552-1D	NASW-7052-1D, Power switch PC board ass'y <WT>			
	1A899552-1F	NASW-7052-1F, Power switch PC board ass'y <490>			
U18	1A899552-1G	NASW-7052-1G, Power switch PC board ass'y <GT>			
	1A899552-1H	NASW-7052-1H, Power switch PC board ass'y <WR>			
	25137053	NCETC-7053 PC board for Holder			
	1A899554-1A	NAETC-7054-1A, Primary terminal PC board ass'y <DD>			
	1A899554-1B	NAETC-7054-1B, Primary terminal PC board ass'y <PP>			
U19	1A899554-1C	NAETC-7054-1C, Primary terminal PC board ass'y <PA>			
	1A899554-1D	NAETC-7054-1D, Primary terminal PC board ass'y <WT>			
	1A899554-1F	NAETC-7054-1F, Primary terminal PC board ass'y <490>			
	1A899554-1G	NAETC-7054-1G, Primary terminal PC board ass'y <GT>			
	1A899554-1H	NAETC-7054-1H, Primary terminal PC board ass'y <WR>			
U19	1A899555-1A	NAPS-7055-1A, Regulator circuit PC board ass'y <DD>			
	1A899555-1B	NAPS-7055-1B, Regulator circuit PC board ass'y <PP>			
	1A899555-1C	NAPS-7055-1C, Regulator circuit PC board ass'y <PA>			
	1A899555-1D	NAPS-7055-1D, Regulator circuit PC board ass'y <WT>			
	1A899555-1F	NAPS-7055-1F, Regulator circuit PC board ass'y <490>			
U19	1A899555-1G	NAPS-7055-1G, Regulator circuit PC board ass'y <GT>			
	1A899555-1H	NAPS-7055-1H, Regulator circuit PC board ass'y <WR>			

[NOTE]

<DD> : 120V model only
 <DT> : Asian model only for 120V
 <GT> : Asian model only for 230V
 <PP> : European model only
 <WT> : World wide model only
 <WR> : Chinese model only
 <494> : TX-DS494 only
 <490> : HT-R490 only
 : Black model only
 <S> : Silver model only
 <G> : Golden model only

BLOCK DIAGRAM

1
2
3
4
5

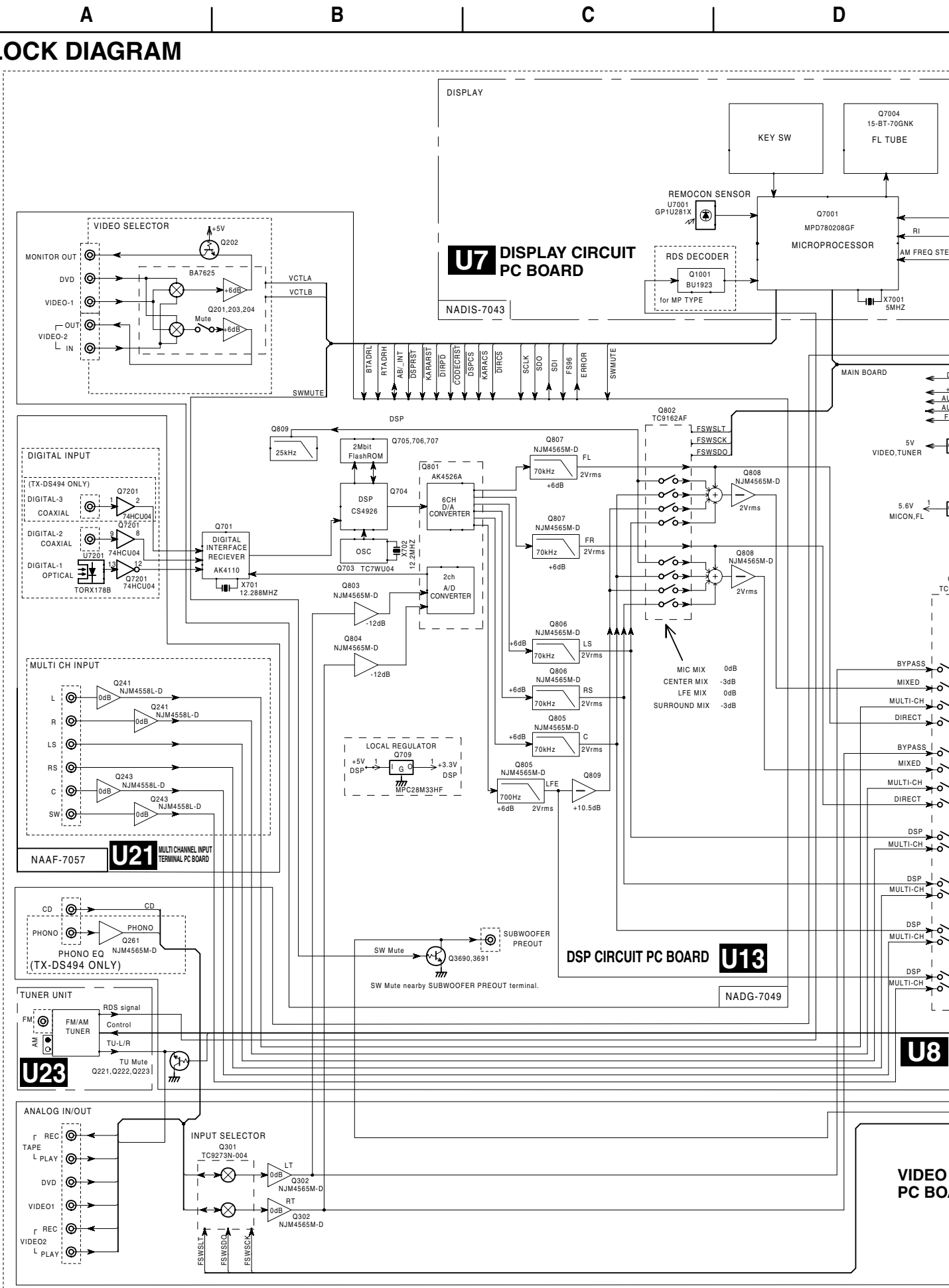

MICROPROCESSOR CONNECTION DIAGRAM

Q7001: MPD78P0208GF

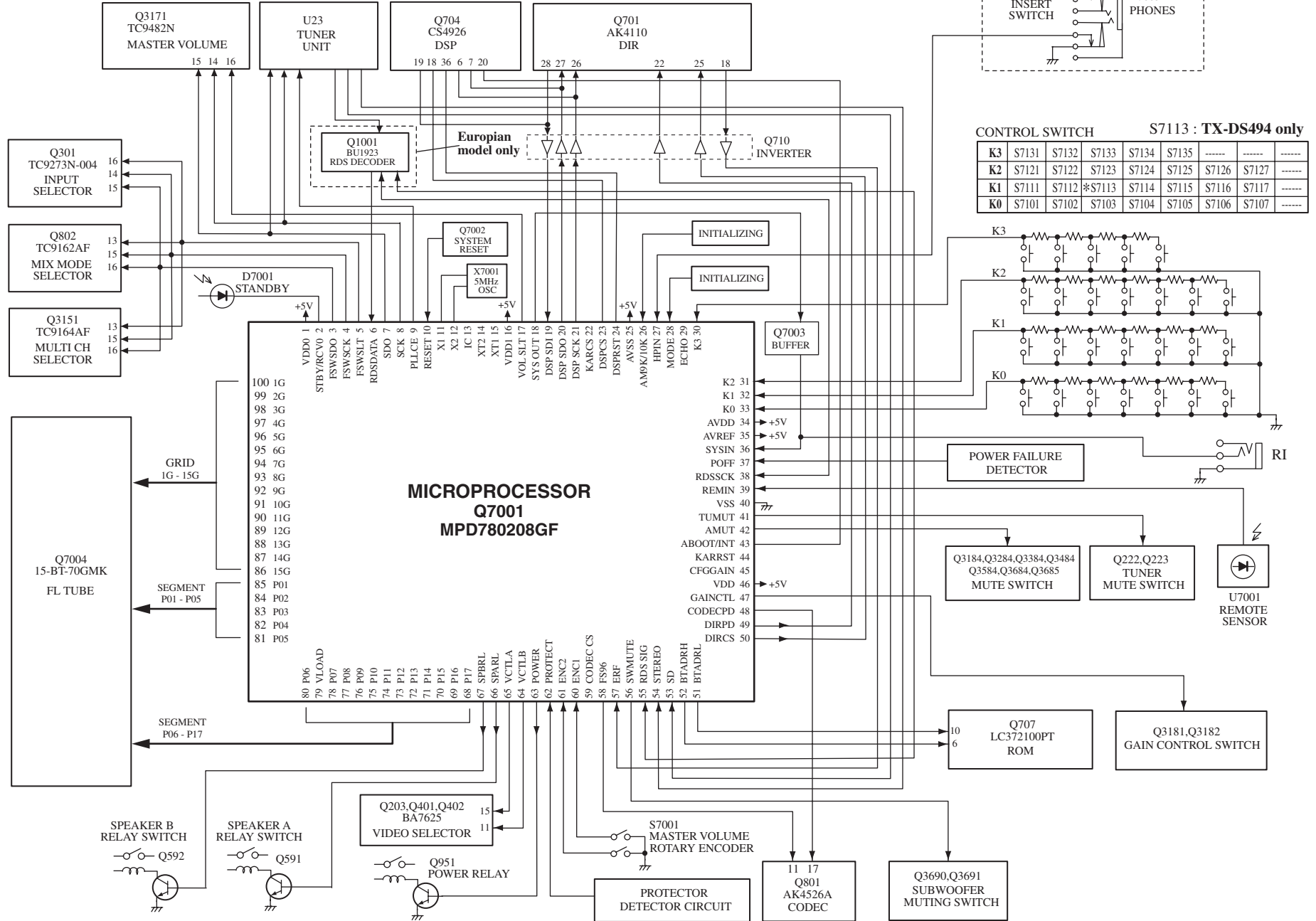

MICROPROCESSOR TERMINAL DESCRIPTIUON

Q7001: MPD78P0208GF

No.	Function	I/O	Description	No.	Function	I/O	Description
1	VDD	I	Power supply terminal. (+5V)	38	RDSSCK	I	Clock input terminal from RDS decoder.
2	STBY/RECV	O	STANDBY/RECEIVED inductor control output terminal.	39	REMIN	I	Signal input terminal from remote sensor.
3	FSWSDO	O	Data output terminal to function switch ICs.	40	VSS	I	Power supply terminal (GND).
4	FSWSCK	O	Clock output terminal to function switch ICs.	41	TUMUT	O	Muting control output terminal for tuner section.
5	FSWSLT	O	Latch output terminal to function switch ICs.	42	AMUT	O	Muting control output terminal for amplifier section.
6	RDSDATA	I	Data input terminal from RDS decoder.	43	ABOOT/INT	I/O	AUTOBOOT and INTREQ I/O terminal for DSP(CS4296).
7	SDO	O	Data output terminal to PLL IC and Master volume IC (TC9482N).	44	KARRST	O	Not used.
8	SCK	O	Clock output terminal to PLL IC and Master volume IC (TC9482N).	45	CFGGAIN	O	Not used.
9	PLLCE	O	Chip enable output terminal to PLL IC.	46	VDD	I	Power supply terminal (+5V).
10	RESET	I	System reset input terminal.	47	GAINCTL	O	Gain control output terminal.
11	X1	O	Ceramic oscillator connection terminals.	48	CODECPD	O	Power down signal output terminal to CODEC(AK4526).
12	X2	I	Connect 5.0MHz ceramic oscillator between the both terminals.	49	DIRPD	O	Power down signal output terminal to DIR (AK4110).
13	GND	I	Internal connection terminal.(to GND)	50	DIRCS	O	Chip enable output terminal to DIR (AK4110).
14	XT2	O	Sub system clock output terminal. Not used.	51	BTADRL	O	Output terminal to set LSB position of address to boot ROM (MX29F002T).
15	XT1	I	Sub system clock input terminal. Not used.(to GND)	52	BTADRH	O	Output terminal to set MSB position of address to boot ROM (MX29F002T).
16	Vdd	I	Power supply terminal. (+5V)	53	SD	I	Broadcast detection input terminal.
17	VOL SLT	O	Latch output terminal to Master volume IC(TC9482N).	54	STEREO	I	Stereo broadcast detection input terminal.
18	SYSOUT	O	System code output terminal.	55	RDSSIG	I	Signal input terminal from RDS decoder.
19	DSPSDI	I	Data input terminal from DIR(AK4110).	56	SWMUTE	O	SW Preout muting control output terminal for amplifier section.
20	DSPSDO	O	Data output terminal to DIR (AK4110),DSP(CS4926,).	57	ERF	I	ERF Signal input terminal from DIR(AK4110).
21	DSPSCK	O	Clock output terminal to DIR (AK4110),DSP(CS4926)	58	FS96	O	FS96 Signal output terminal to CODEC(AK4526)
22	KARCS	O	Not used.	59	CODECCS	O	Not used.
23	DSPCS	O	Chip enable output terminal to DSP(CS4926).	60	ENC1	I	Volume control input terminal.
24	DSPRST	O	Reset output terminal to DSP(CS4926).	61	ENC2	I	Volume control input terminal.
25	AVSS	I	Power supply terminal.(GND)	62	PROTECT	I	Detection input terminal for protection circuit.
26	AM9K/10K	I	Initializing input terminal for AM band step.	63	POWER	O	Relay control output terminal for power.
27	HPIN	I	Detection input terminal from headphone..	64	VCTLB	O	Video selector control output terminal.
28	MODE	I	Initializing input terminal of operation mode..	65	VCTLA	O	Video selector control output terminal.
29	ECHO	I	Not used.	66	SPARL	O	Control output terminal for SPEAKER A relay.
30-33	K3-K0	I	Operation key connection terminals.	67	SPBRL	O	Control output terminal for SPEAKER B relay.
34	AVDD	I	Power supply terminal.(+5V)	68-78	P17-P7	O	Segment output terminals for FL tube.
35	AVREF	I	Reference voltage terminal.	79	VLOAD		Power supply terminal for FL tube.
36	SYSIN	I	System code input terminal.	80-85	P6-P1	O	Segment output terminals for FL tube.
37	POFF	I	Power failure detection terminal.	86-100	15G-1G	O	Grid output terminals for FL tube.

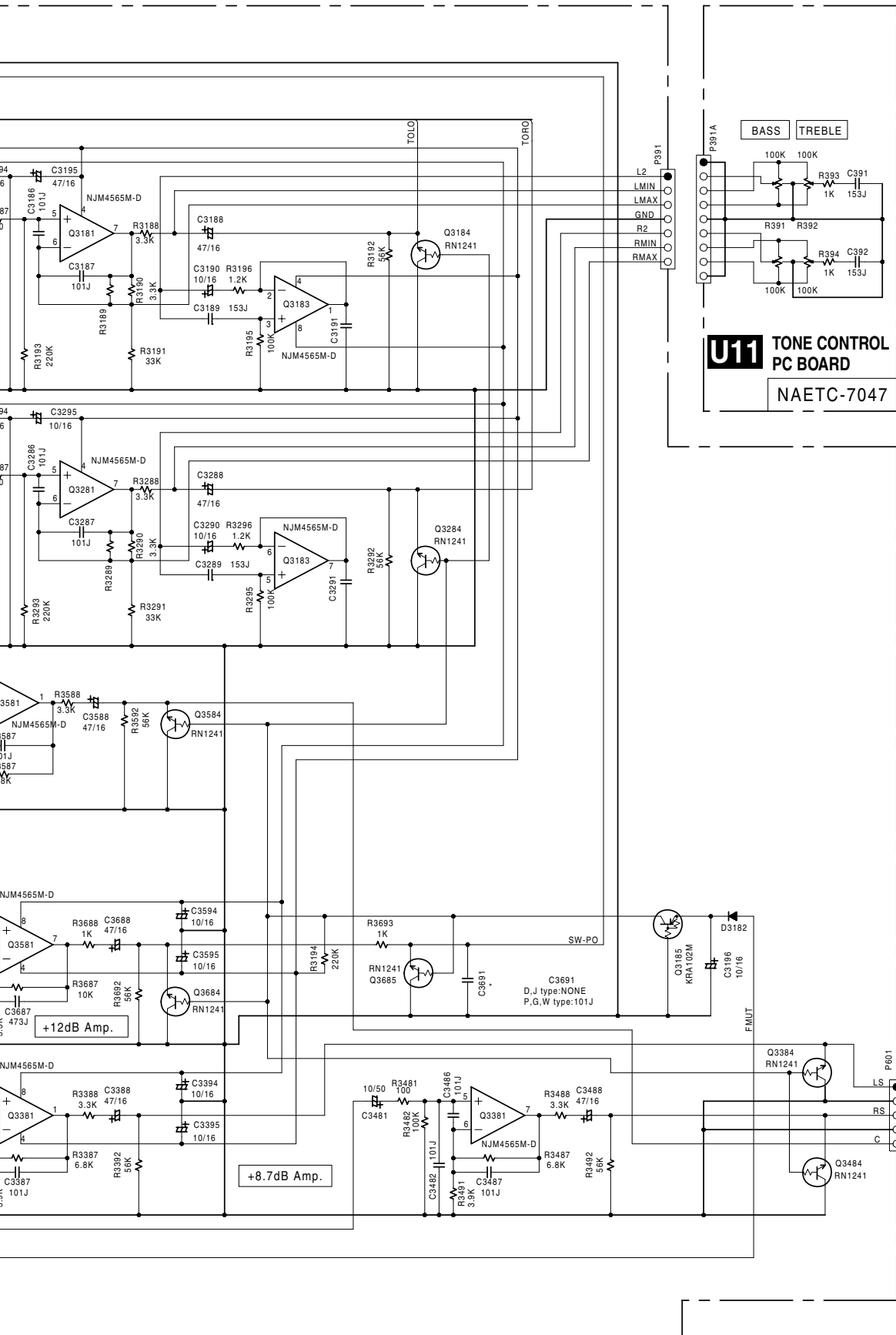

E

F

G

	TX-DS494	HT-R490
R710	330	NO
C714	NO	104Z

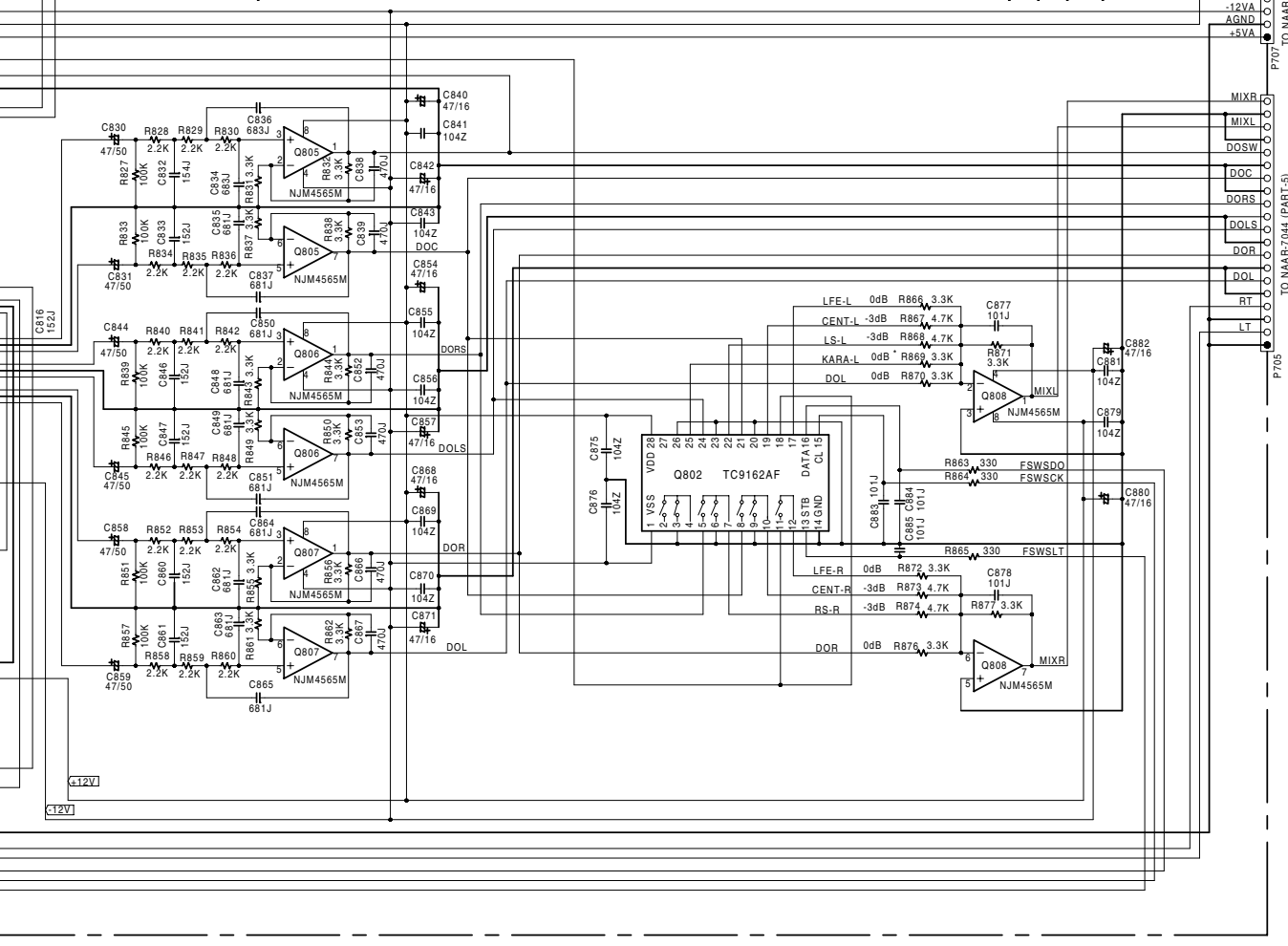
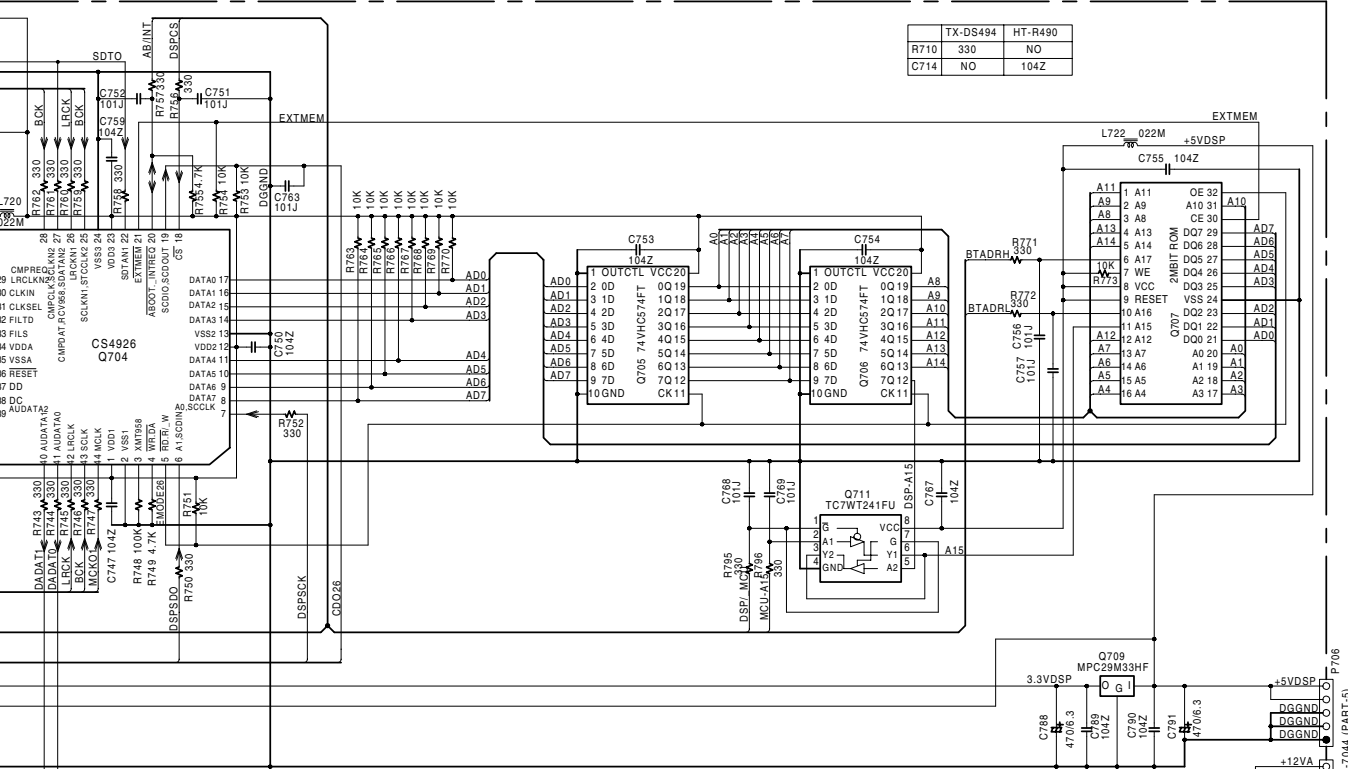

TO MAAR-704 (PART-5)

TO MAAR-704 (PART-5)

TO MAAR-704 (PART-5)

TO MAAR-704 (PART-5)

SCHEMATIC DIAGRAM-3

NAAR-7044 U8 MAIN PC BOARD

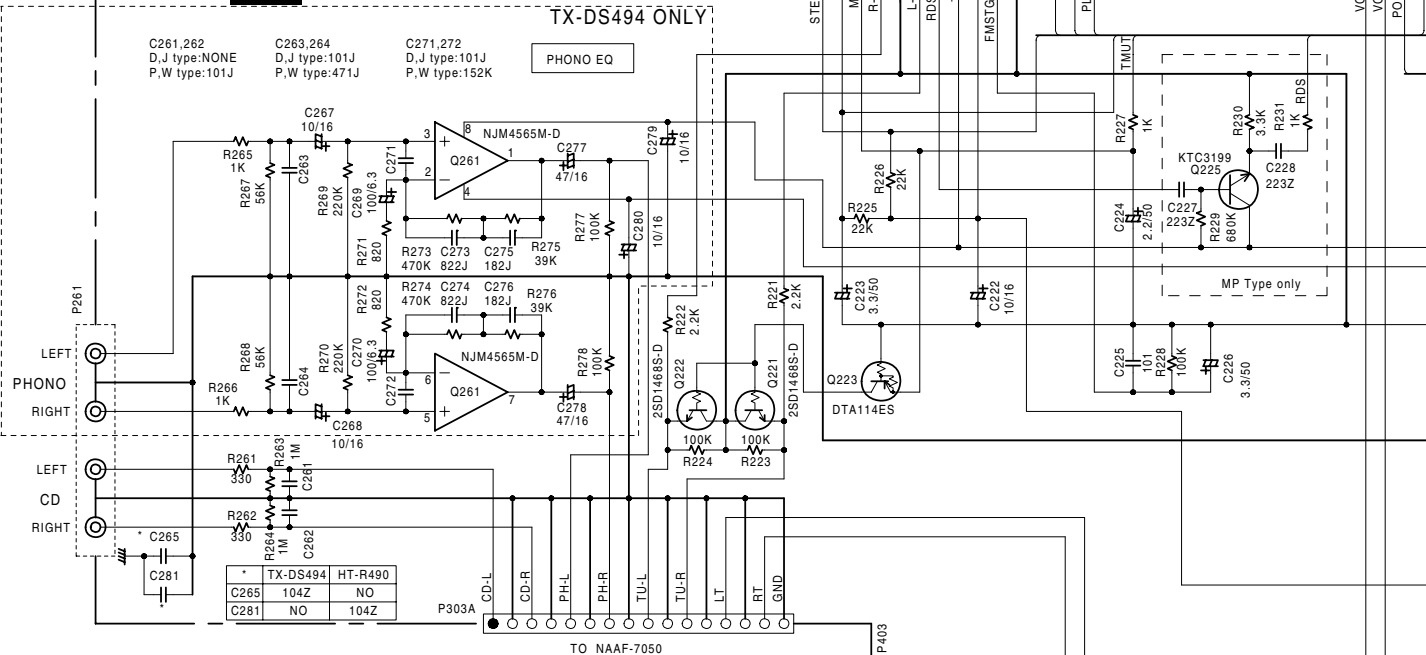

NAAF-7057 U21 MULTI CHANNEL INPUT TERMINAL PC BOARD

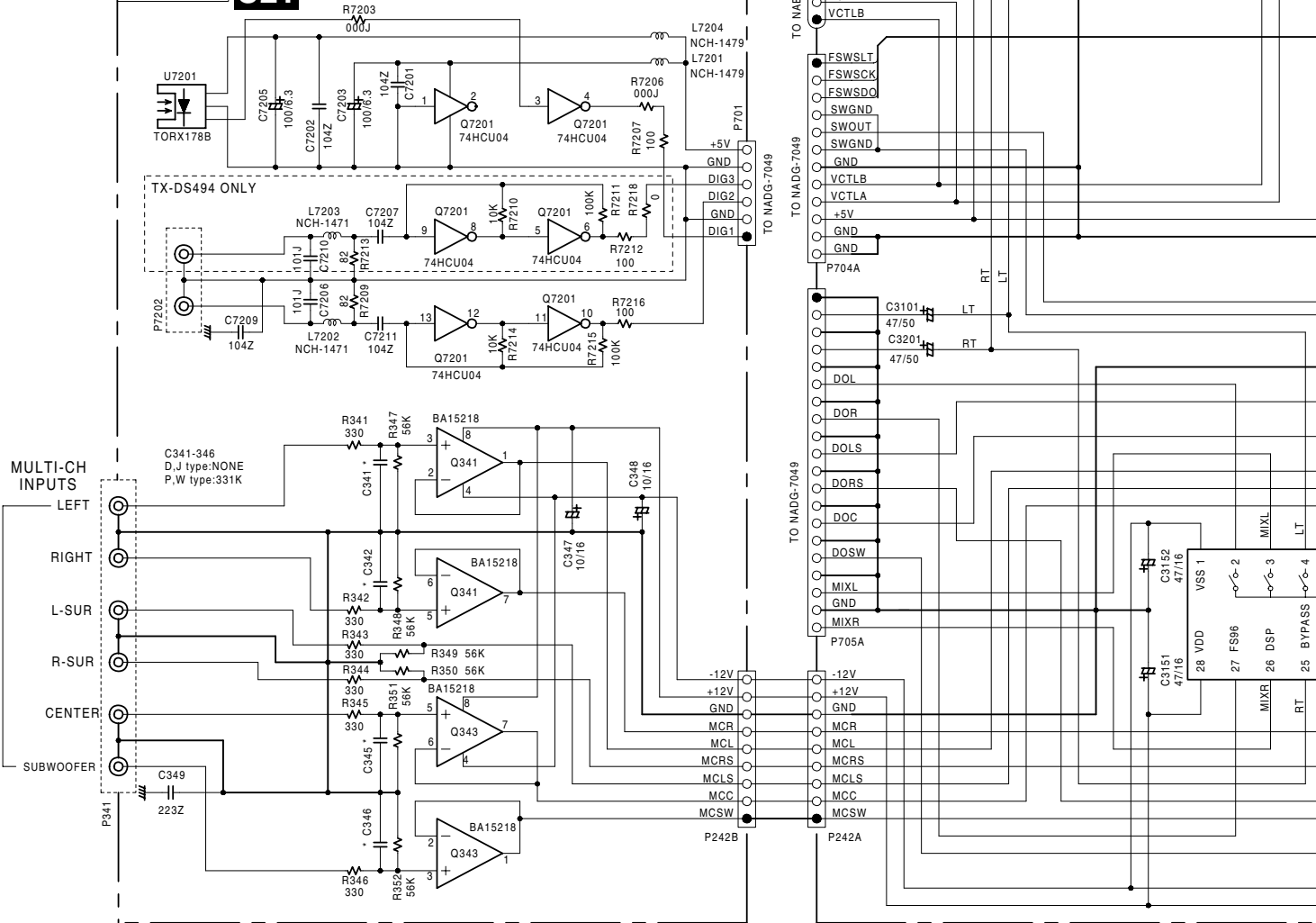

E

F

G

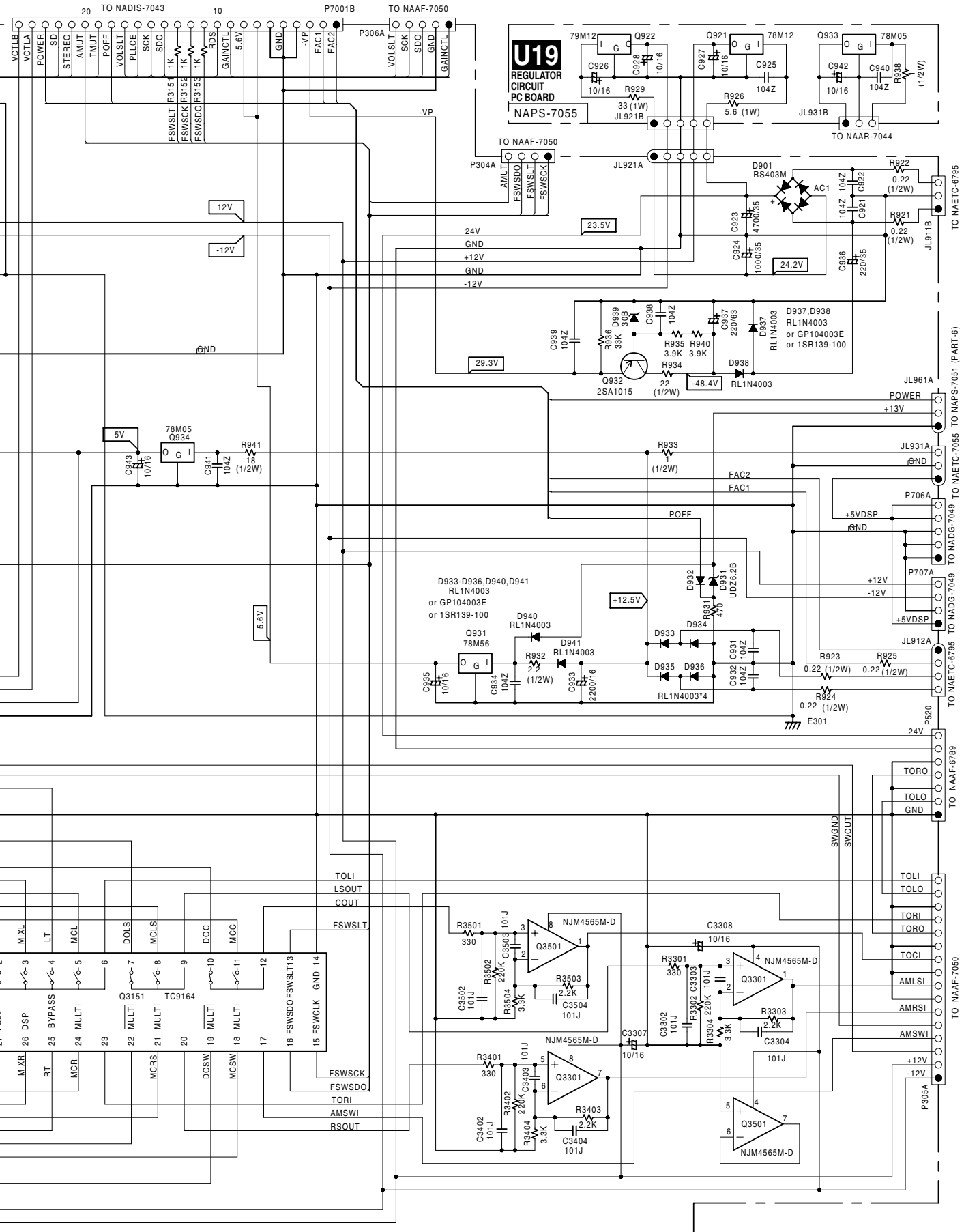

SCHEMATIC DIAGRAM-4

SURROUND SPEAKER TERMINAL PC BOARD U4

NAAF-6790

U2 SURROUND CHANNEL POWER AMPLIFIER PC BOARD

NAETC-6790

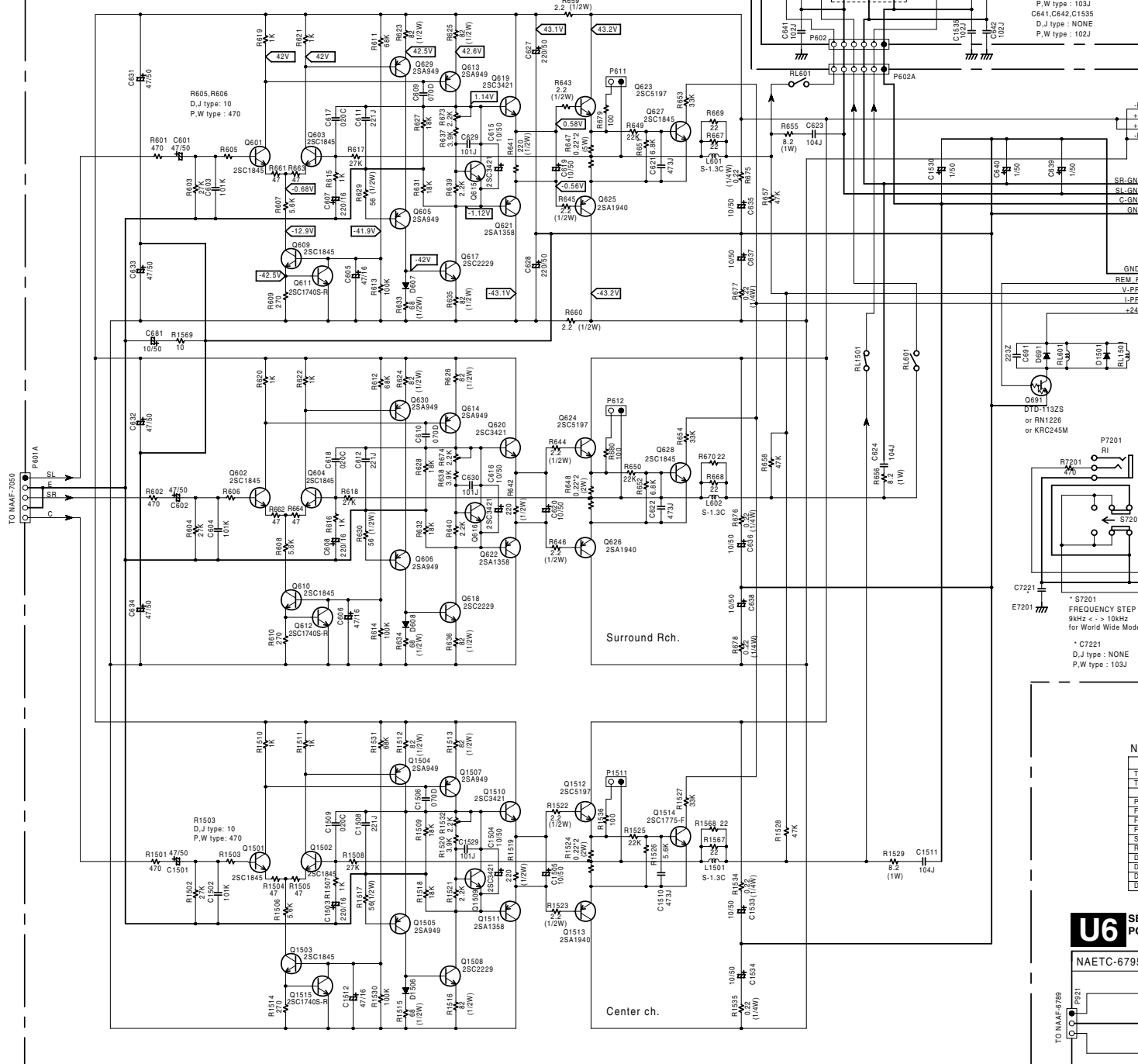

- Q507, Q508, Q509, Q510, Q513, Q514, Q605, Q606, Q613, Q614, Q629, Q630, Q1504, Q1505, Q1507, KTA1024 or 2SA949
- Q515, Q516, Q617, Q618, Q1508, KTC3206 or 2SC2229
- Q523, Q524, Q623, Q624, Q1512, KTD718 or 2SC5197 or 2SC4467
- Q525, Q526, Q625, Q626, Q1513, KTB888 or 2SA1940 or 2SA1694
- Q519, Q520, Q619, Q620, Q1510, 2SC3421 or KTD600K
- Q521, Q522, Q621, Q622, Q1511, 2SA1358 or KTB831K
- Q591, Q592, Q951, KRC105M or DTC1233JS or RN1205
- Q691, DTD1132S or RN1226 or KRC245M
- Q529, Q530, Q611, Q612, Q1515, KTC3199 or 2SC1740 or 2SC2458
- Q501, Q502, Q503, Q504, Q505, Q506, Q527, Q528, Q581, Q582, Q601, Q602, Q603, Q604, Q609, Q510, Q627, Q628, Q1501, Q1502, Q1503, Q1514, 2SC1845 or 2SC1775A

THIS SYMBOL LOCATED NEAR THE FUSE INDICATES THAT THE FUSE USED IS SLOW OPERATING TYPE FOR CONTINUED PROTECTION AGAINST FIRE HAZARD. HAZARD REPLACE WITH SAME TYPE FUSE. FOR FUSE RATING REFER TO THE MAKING ADJACENT TO THE SYMBOL.

CE SYMBOLE INDIQUE QUE LE FUSIBLE UTILISE EST A LENT, E POUR UNE PROTECTION PERMANENTE, N'UTILISER QUE DES FUSIBLES DE MEME TYPE. CE DARNIER EST INDIQUE LA QU LE PRESENT SYMBOLE EST APOSE.

CAUTION
FOR CONTINUED PROTECTION AGAINST FIRE HAZARD, REPLACE ONLY WITH FUSE OF SAME TYPE AND RATING INDICATED.

ATTENTION
AFIN D'ASSURER UNE PROTECTION PERMANENTE CONTRE LES RISQUES D'INCENDIE, REMPLACER UNIQUEMENT PAR UN FUSIBLE DE MEME TYPE ET CALIBRATION COMME INDIQUE.

SURROUND SPEAKERS
C625, C626, C1526
D.J type : NONE
P.W type : 103J
C641, C642, C1535
D.J type : NONE
P.W type : 102J

SR-GND
SL-GND
C-GND
GNND

REML R
V-PR
L-PR
+24V

* S7201
FREQUENCY STEP
9kHz < - > 10kHz
for World Wide Mode

* C7221
D.J type : NONE
P.W type : 103J

NA
TS
TS
PS
FS
FS
FS
SS
DI
DI
DI
DI

U6
SE
PC
NAETC-6795

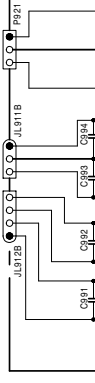

1

2

3

4

5

U4
NAETC-6792

U1 FRONT CHANNEL POWER AMPLIFIER PC BOARD

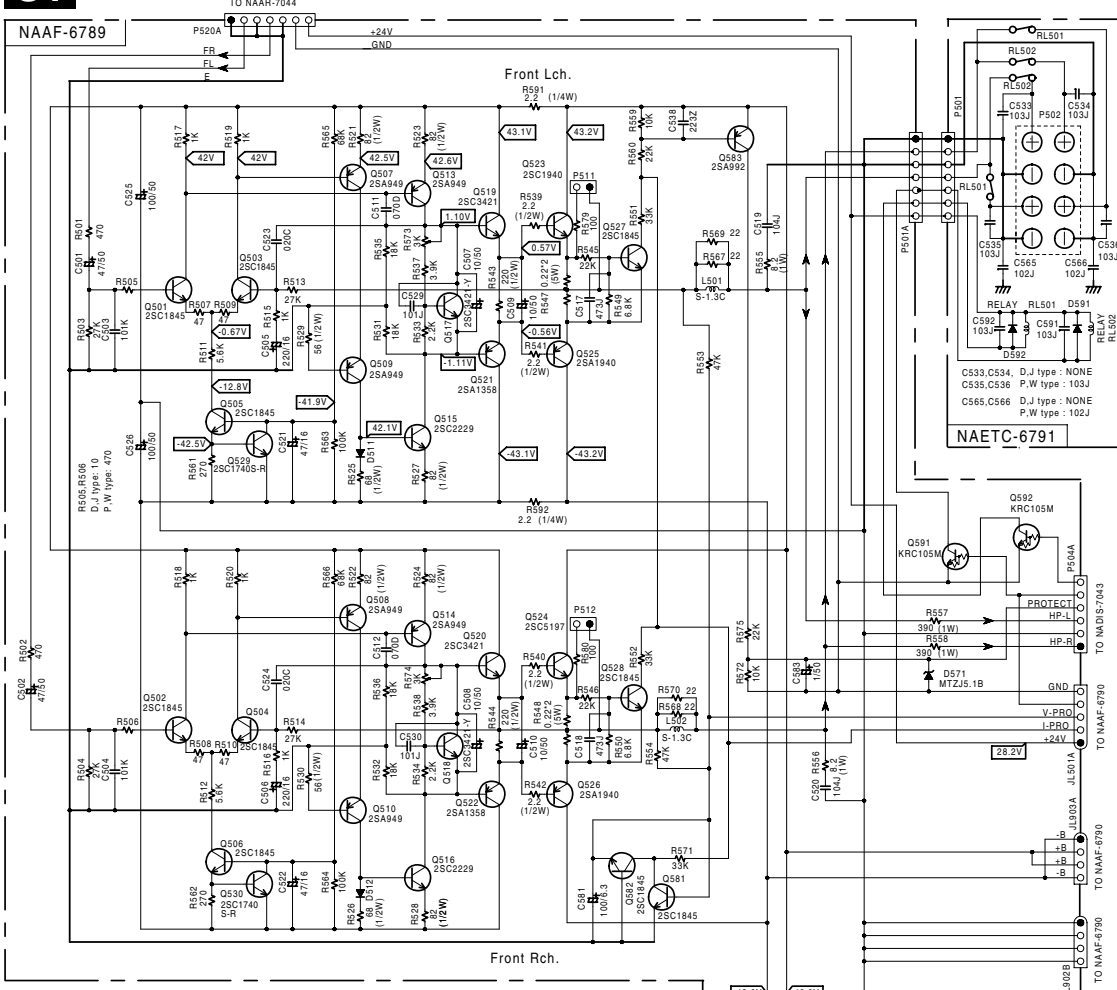

U3 FRONT SPEAKER TERMINAL PC BOARD

NAETC-6791

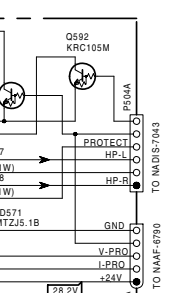

NAPS-7051

	MDD TYPE	MPP TYPE	MW/MG TYPE	MJJ TYPE
T901	NPT-1384D	AS-1384P	NPT-1384DG	NPT-1384J
T902	NPT-1358D	AS-1358P	NPT-1358DG	NPT-1358J
F911	AS-UC	AS-CEE	AS-CEE2	AS-W
F922	NO	YES	YES	NO
F933	NO	YES	NO	NO
S902	NO	NO	NO	NO
R901	YES	NO	NO	NO
D951	NO	YES	YES	NO
D952	YES	YES	YES	YES
D953	NO	YES	YES	NO
D954	NO	YES	YES	NO

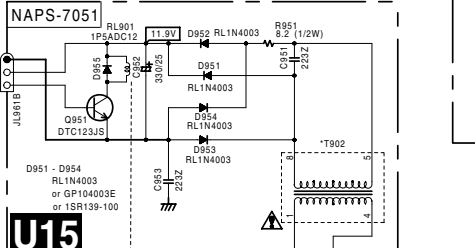

U18 PRIMARY TERMINAL PC BOARD

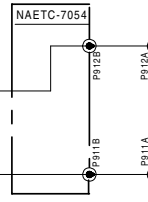

U6 SECONDARY TERMINAL PC BOARD

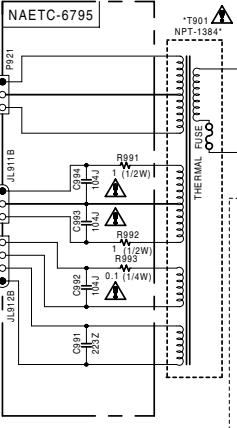

U16 POWER SWITCH PC BOARD



MD TYPE (120V/60Hz)
 MJ TYPE (100V/50/60Hz)
 MP TYPE (230V-240V/50Hz)
 MG TYPE (220V-230V/50/60Hz)
 MW TYPE (220V-230V/50Hz, 120V/60Hz SWITCHABLE)

SCHEMATIC DIAGRAM-5

NADIS-7043 U7 DISPLAY CIRCUIT PC BOARD

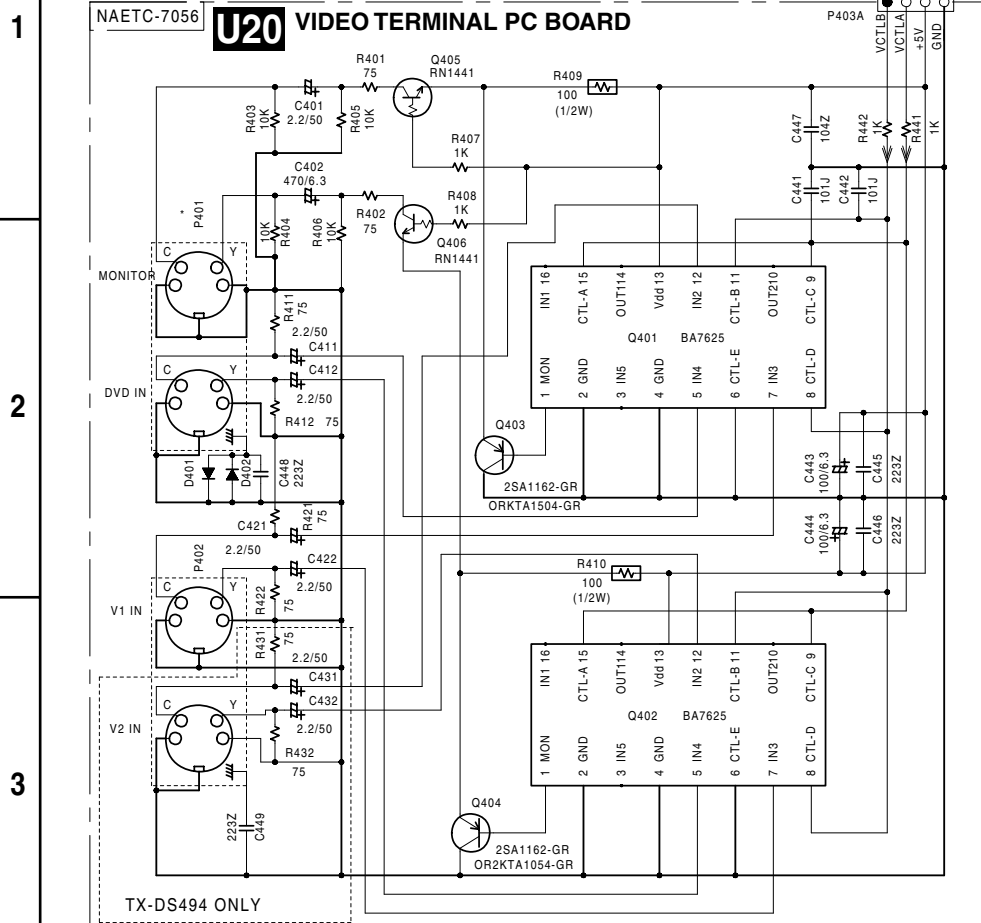

* TX-DS494 P401 2P
* HT-R490 P401 3P

	MDD	MPP	MWT/MWR	MGT/MPA	MJ	HT-R490
R7018	47K	47K	47K	47K	47K	NO
R7019	1K	1K	1K	1K	1K	NO
R7020	NO	18K	12K	10K	3.3K	10K
R7021	10K	2.2K	3.3K	8.2K	12K	NO
R7158	NO	NO	NO	NO	NO	000J
R7159	000J	000J	000J	000J	000J	NO
S7113	YES	YES	YES	YES	YES	NO
P7026	2P	2P	3P	2P	2P	2P
P504	6P	6P	6P	6P	6P	3P
C7014	NO	104Z	104Z	104Z	NO	NO

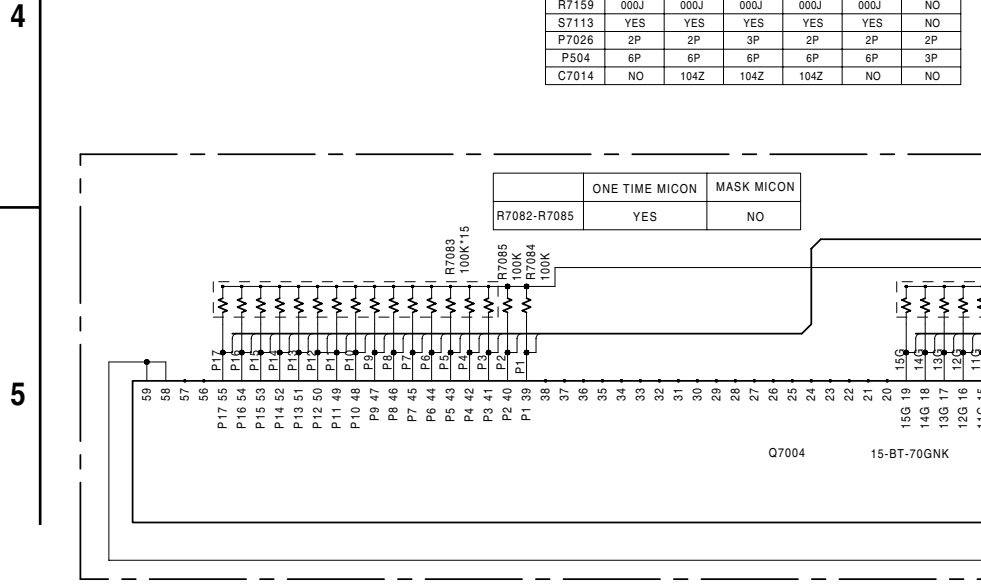

	ONE TIME MICON	MASK MICON
R7082-R7085	YES	NO

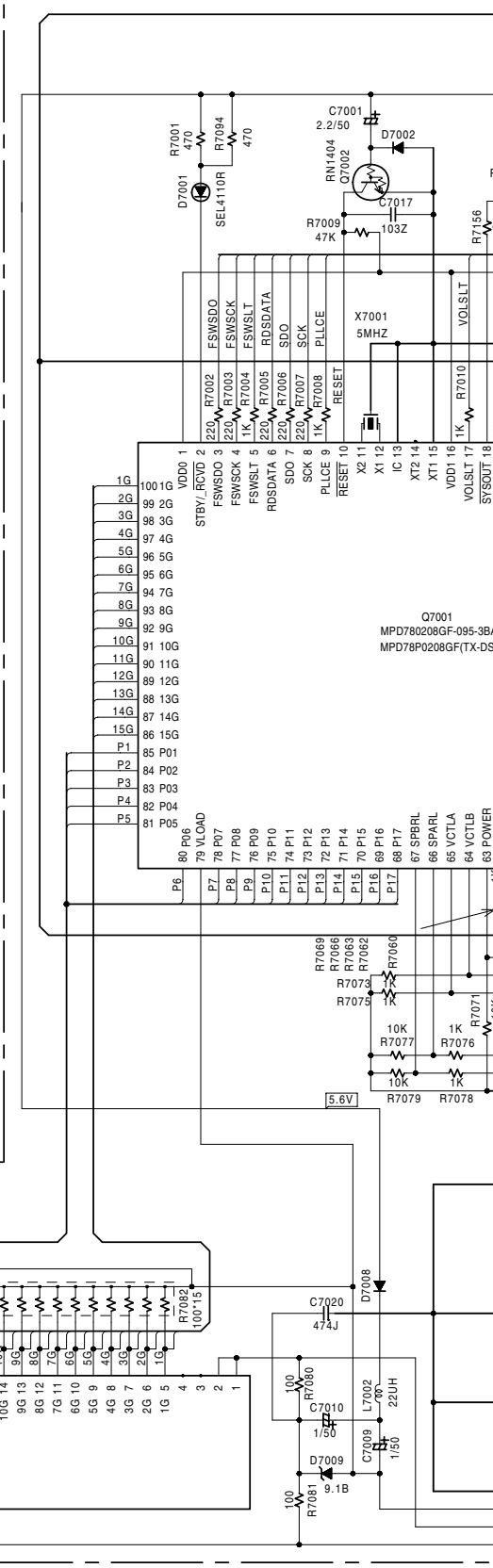

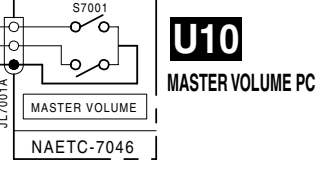
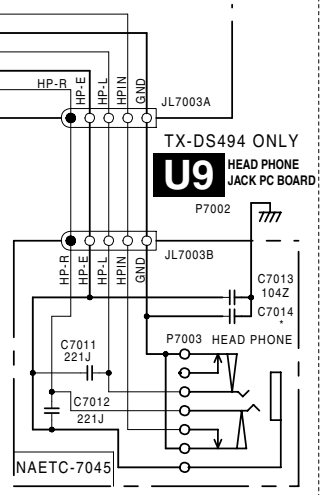
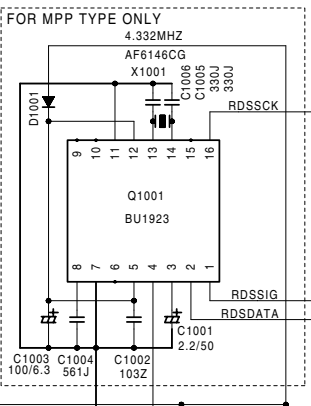
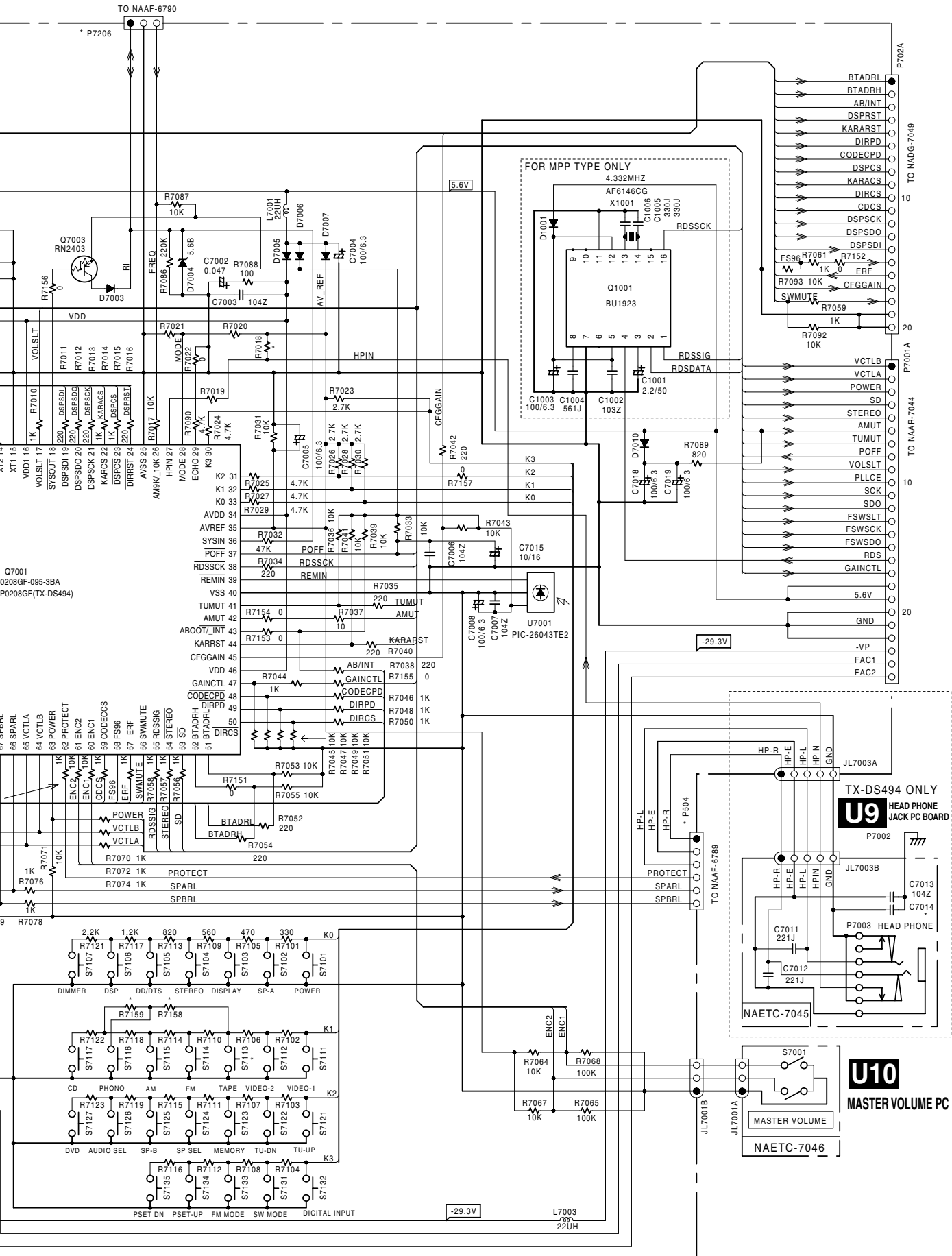

Q7001 0208GF-095-3BA P0208GF(TX-DS494)

66 SPARL
65 VCTLA
64 VCTLB
63 POWER
62 PROTECT
61 ENC2
60 ENC1
59 CODECS
58 FS96
57 ERF
56 SWMUTE
55 RDSSIG
54 STEREO
53 SD
52 BTADRH
51 BTADRL
50 DIRCS

DIMMER
 DSP
 DD/DTS
 STEREO
 DISPLAY
 SP-A
 POWER

CD
 PHONO
 AM
 FM
 TAPE
 VIDEO-2
 VIDEO-1

DVD
 AUDIO SEL
 SP-B
 SP SEL
 MEMORY
 TU-DN
 TU-UP

PSET DN
 PSET-UP
 FM MODE
 SW MODE
 DIGITAL INPUT

P702A
 TO NADG-7049
 10
 BTADRL
 BTADRH
 AB/INT
 DSPRST
 KARARST
 DIRPD
 CODECPD
 DSPCS
 KARACS
 DIRCS
 CDCS
 DSPSCK
 DSPSDO
 DSPSDI
 FS96 R7061
 R7152
 1K
 ERF
 R7093 10K
 CFGGAIN
 SWMUTE
 R7059
 1K
 R7092 10K
 20
 P7001A
 TO NAAF-7044
 10
 VCTLB
 VCTLA
 POWER
 SD
 STEREO
 AMUT
 TUMUT
 POFF
 VOLSLT
 PLLCE
 SCK
 SDO
 FSWSLT
 FSWSCK
 FSWSDO
 RDS
 GAINCTL
 5.6V
 20
 GND
 -VP
 FAC1
 FAC2

-29.3V

-29.3V

5.6V

PRINTED CIRCUIT BOARD PARTS LIST-1

NOTE: <DD> : 120V model only <494>: TX-DS494 only
 <DT> : Asian model only for 120V <490>: HT-R490 only
 <GT> : Asian model only for 230V
 <PP> : European model only
 <PA> : Australian model only
 <WT> : World wide model only
 <WR> : Chinese model only

NOTE: THE COMPONENTS IDENTIFIED BY MARK  ARE CRITICAL FOR RISK OF FIRE AND ELECTRIC SHOCK. REPLACE ONLY WITH PART NUMBER SPECIFIED.

U1

FRONT CHANNEL POWER AMPLIFIER PC BOARD
(NAAF-6789-2A/2B/2C/2D)

CIRCUIT NO.	PART NO.	DESCRIPTION
	Transistors	
Q501-Q506	2210755 or 2210756 or 2211732 or 2211733 or 2215895 or 2215896	2SC1775A-E or 2SC1775A-F or 2SC1845-F or 2SC1845-E or KTC3200-GR or KTC3200-BL
Q507-Q510	2211353 or 2215844 or 2215843	2SA949-O or KTA1024-Y or KTA1024-O
Q513,Q514	2211353 or 2215844 or 2215843	2SA949-O or KTA1024-Y or KTA1024-O
Q515,Q516	2215854 or 2215853	KTC3206-Y or KTC3206-O
Q519,Q520	2203523 or 2203524	KTD600K-Y or KTD600K-GR
Q521,Q522	2203513 or 2203514	KT631K-Y or KT631K-GR
Q527,Q528	2210755 or 2210756 or 2211732 or 2211733 or 2215895 or 2215896	2SC1775A-E or 2SC1775A-F or 2SC1845-F or 2SC1845-E or KTC3200-GR or KTC3200-BL
Q529,Q530	2213284 or 2212115 or 2215864	2SC1740S-R or 2SC2458-GR or KTC3199-GR
Q581,Q582	2210755 or 2210756 or 2211732 or 2211733 or 2215895 or 2215896	2SC1775A-E or 2SC1775A-F or 2SC1845-F or 2SC1845-E or KTC3200-GR or KTC3200-BL
Q583	2211792 or 2211793 or 2215885 or 2215886	2SA992-F or 2SA992-E or KTA1268-GR or KTA1268-BL
Q591,Q592	2214660 or 2213640 or 2215830	RN1205 or DC123JS or KRC105M
	Diodes	
D511,D512	223163 or 223205	1SS133 or 1SS270A
D571	224470512	MTZJ5.1B
	Coils	
L501,L502	231176S	S-1.3C
	Capacitors	
C501,C502	354784709	47uF,50V, Elect.
C503,C504	374721015	100pF+/-10%,50V, Plastic
C505,C506	354742219	220uF,16V, Elect.
C507-C510	354781009	10uF,50V, Elect.
C517,C518	374724734	0.047uF+/-5%,50V, Plastic
C519,C520	374721044	0.1uF+/-5%,50V, Plastic
C521,C522	354744709	47uF,16V, Elect.

CIRCUIT NO.	PART NO.	DESCRIPTION
C525,C526	354781019	100uF,50V, Elect.
C581	354721019	100uF,6.3V, Elect.
C583	354780109	1uF,50V, Elect.
C905,C906	374721044	0.1uF+/-5%,50V, Plastic
C915,C916	3504344	10000uF,50V, Elect.
	Resistors	
R521-R524	443528204	82ohm+/-5%,1/2W, Metal oxide
R525,R526	443526804	68ohm+/-5%,1/2W, Metal oxide
R527,R528	443528204	82ohm+/-5%,1/2W, Metal oxide
R529,R530	443525604	56ohm+/-5%,1/2W, Metal oxide
R543,R544	443522214	220ohm+/-5%,1/2W, Metal oxide
R547,R548	4000132 or 4000201 or 4500245	0.22ohm+/-5%,5W, Metal plate or 0.22ohm+/-5%,5W, Metal plate or 0.22ohm+/-5%,5W, Metal plate
R555,R556	453630824	8.2ohm+/-5%,1W, Metal oxide
R557,R558	443623914	390ohm+/-5%,1W, Metal oxide <494>
R573,R574	5210260	N06HR3KTBC, Trimming resistor
R591,R592	4500171F	2.2ohm+/-5%,1/4W, Metal oxide
	Sockets	
JL501A	25051109	NSCT-5P896
JL902B	25050268	NSCT-4P96
JL903A	25051108	NSCT-4P895
	Plugs	
P504A	25055441	NPLG-3P423
P511,P512	25055038	NPLG-2P29
P921A	25055175	NPLG-3P159

U2

SURROUND CHANNEL POWER AMPLIFIER PC BOARD
(NAAF-6790-2A/2B/2C/2D)

CIRCUIT NO.	PART NO.	DESCRIPTION
	Transistors	
Q1501-Q1503,Q1514	2210755 or 2210756 or 2211732 or 2211733 or 2215895 or 2215896	2SC1775A-E or 2SC1775A-F or 2SC1845-F or 2SC1845-E or KTC3200-GR or KTC3200-BL
Q1504,Q1505,Q1507	2211353 or 2215843 or 2215844	2SA949-O or KTA1024-O or KTA1024-Y
Q601-Q604	2210755 or 2210756 or 2211732 or 2211733 or 2215895 or 2215896	2SC1775A-E or 2SC1775A-F or 2SC1845-F or 2SC1845-E or KTC3200-GR or KTC3200-BL
Q605,Q606	2211353 or 2215843 or 2215844	2SA949-O or KTA1024-O or KTA1024-Y
Q609,Q610	2210755 or 2210756 or 2211732 or 2211733 or 2215895 or 2215896	2SC1775A-E or 2SC1775A-F or 2SC1845-F or 2SC1845-E or KTC3200-GR or KTC3200-BL

PRINTED CIRCUIT BOARD PARTS LIST-2

NOTE: <DD> : 120V model only <494>: TX-DS494 only
 <DT> : Asian model only for 120V <490>: HT-R490 only
 <GT> : Asian model only for 230V
 <PA> : Australian model only
 <PP> : European model only
 <WT> : World wide model only
 <WR> : Chinese model only

NOTE: THE COMPONENTS IDENTIFIED BY MARK  ARE CRITICAL FOR RISK OF FIRE AND ELECTRIC SHOCK. REPLACE ONLY WITH PART NUMBER SPECIFIED.

CIRCUIT NO.	PART NO.	DESCRIPTION	CIRCUIT NO.	PART NO.	DESCRIPTION
Q611,Q612,Q1515	2212115 or 2213284 or 2215864	2SC2458-GR or 2SC1740S-R or KTC3199-GR	R641,R642,R1519 R643-R646 R647,R648,R1524	443522214 453530224 4000132 or 4000201 or 4500245	220ohm+/-5%,1/2W, Metal oxide 2.2ohm+/-5%,1/2W, Metal oxide 0.22ohm+/-5%,5W or 0.22ohm+/-5%,5W or 0.22ohm+/-5%,5W, Metal plate
Q613,Q614	2211353 or 2215843 or 2215844	2SA949-O or KTA1024-O or KTA1024-Y	R655,R656 R659,R660 R673,R674,R1532 R675-R678	453630824 4500268F 5210288 4500159F	8.2ohm+/-5%,1W, Metal oxide 2.2ohm+/-5%,1/2W, Metal oxide N06HR2.2KTBE, Trimming resistor 0.22ohm+/-5%,1/4W, Metal oxide
Q615,Q616,Q1509	2212653 or 2212654	2SC3421-O or 2SC3421-Y			
Q617,Q618,Q1508	2211633 or 2215853 or 2215854	2SC2229-O or KTC3206-O or KTC3206-Y	RL601	25065563 or 25065590 or 25065618	NRL-2P5A-DC24-129 or NRL-2P8A-DC24-144 or NRL-2P5A-DC24-158
Q619,Q620,Q1510	2203523 or 2203524	KTD600K-Y or KTD600K-GR	RL1501	25065574	NRL-1P5A-DC24-134
Q621,Q622,Q1511	2203513 or 2203514	KT631K-Y or KT631K-GR	S7201	25065286	NSS-22112 <WR,WT>
Q627,Q628	2210755 or 2210756 or 2211732 or 2211733 or 2215895 or 2215896	2SC1775A-E or 2SC1775A-F or 2SC1845-F or 2SC1845-E or KTC3200-GR or KTC3200-BL	P7201	25045504	NPJ-1PDBL319
Q629,Q630	2211353 or 2215843 or 2215844	2SA949-O or KTA1024-O or KTA1024-Y	JL501B JL902A JL903B	25050282 25051108 25050268	NSCT-5P110 NSCT-4P895 NSCT-4P96
Q691	2213650 or 2214680 or 2216060	DTD113ZS or RN1226 or KRC245M	P601A P611,P612,P1511 P7206A	25055236 25055038 25055132 25055133	NPLG-5P220 NPLG-2P29 NPLG-2P116 <DD,PP,PA,GT,490> NPLG-3P117 <WR,WT>
D1501,D1506	223163 or 223205	1SS133 or 1SS270A	P589	260224	CP-1S
D607,D608,D691	223163 or 223205	1SS133 or 1SS270A	U3		
L601,L602,L1501	231176S	S-1.3C	FRONT SPEAKER TERMINAL PC BOARD (NAETC-6791-2A/2B/2C/2D)		
C1504,C1505 C1533,C1534 C601,C602,C1501 C603,C604,C1502 C605,C606,C1512 C607,C608,C1503 C615,C616 C619,C620 C621,C622,C1510 C623,C624,C1511 C627,C628 C631-C634 C635-C638,C681 C639,C640,C1530	354781009 354781009 354784709 374721015 354744709 354742219 354781009 354781009 374724734 374721044 354782219 354784709 354781009 354780109	10uF,50V, Elect. 10uF,50V, Elect. 47uF,50V, Elect. 100pF+/-10%,50V, Plastic 47uF,16V, Elect. 220uF,16V, Elect. 10uF,50V, Elect. 10uF,50V, Elect. 0.047uF+/-5%,50V, Plastic 0.1uF+/-5%,50V, Plastic 220uF,50V, Elect. 47uF,50V, Elect. 10uF,50V, Elect. 1uF,50V, Elect.	CIRCUIT NO.	PART NO.	DESCRIPTION
R1512,R1513,R151 R1522,R1523 R1529 R1534,R1535 R539-R542 R623-R626 R629,R630,R1517 R633,R634,R1515 R635,R636	443528204 453530224 453630824 4500159F 453530224 443528204 443525604 443526804 443528204	82ohm+/-5%,1/2W, Metal oxide 2.2ohm+/-5%,1/2W, Metal oxide 8.2ohm+/-5%,1W, Metal oxide 0.22ohm+/-5%,1/4W, Metal oxide 2.2ohm+/-5%,1/2W, Metal oxide 82ohm+/-5%,1/2W, Metal oxide 56ohm+/-5%,1/2W, Metal oxide 68ohm+/-5%,1/2W, Metal oxide 82ohm+/-5%,1/2W, Metal oxide	D591,D592 C533-C536 RL501,RL502 P501 P502	223163 or 223205 374721034 25065563 or 25065590 or 25065618 2009990572AUL 25060296 or 25060304	1SS133 or 1SS270A 0.01uF+/-5%,50V, Plastic <PP,PA,GT,WR,WT> NRL-2P5A-DC24-129 or NRL-2P8A-DC24-144 or NRL-2P5A-DC24-158 NSAS-14P0781 NTM-8PDMN227 or NTM-8PDMN235
			U4		
			SURROUND SPEAKER TERMINAL PC BOARD (NAETC-6792-2A/2B/2C/2D)		
			CIRCUIT NO.	PART NO.	DESCRIPTION
			C625,C626,C1526	374721034	0.01uF+/-5%,50V, Plastic <PP,PA,GT,WR,WT>
			P602	2009990571AUL	NSAS-12P0780
			P603	25060297 or 25060303	NTM-6PDMN228 or NTM-6PDMN234

PRINTED CIRCUIT BOARD PARTS LIST-3

NOTE: <DD> : 120V model only <494>: TX-DS494 only
 <DT> : Asian model only for 120V <490>: HT-R490 only
 <GT> : Asian model only for 230V
 <PP> : European model only
 <PA> : Australian model only
 <WT> : World wide model only
 <WR> : Chinese model only

NOTE: THE COMPONENTS IDENTIFIED BY MARK  ARE CRITICAL FOR RISK OF FIRE AND ELECTRIC SHOCK. REPLACE ONLY WITH PART NUMBER SPECIFIED.

U6

SECONDARY TERMINAL PC BOARD
(NAETC-6795-2A/2B/2C/2D)

CIRCUIT NO.	PART NO.	DESCRIPTION
	Resistors	
R991,R992	453530104	1ohm+/-5%,1/2W, Metal oxide
R993	4500229	0.1ohm+/-5%,1/4W, Metal oxide
	Sockets	
JL911A	25051107	NSCT-3P894
JL912B	25050281	NSCT-4P109
P921	2009990570AUL	NSAS-6P0779

U7

DISPLAY CIRCUIT PC BOARD
(NADIS-7043-1A/1B/1C/1D/1F)

CIRCUIT NO.	PART NO.	DESCRIPTION
	FL tube	
Q7004	212218	15-B-80GNK
	Remote sensor	
U7001	241330 or 241337	PIC-26043E2 or PIC-37043E2
	ICs	
Q1001	22241297R2	BU1923F <PP>
Q7001	22241658R3	MPD780208GF-095-3BA
	Transistors	
Q7002	2216210R2 or 2214490R2	KRC104S or RN1404
Q7003	2216230R2 or 2214540R2	KRA103S or RN2403
	Diode	
D1001	223234R2 or 223269R2	1SS352 or 1SS355 <PP>
D7001	225290	SEL4110R
D7002	223234R2 or 223269R2	1SS352 or 1SS355
D7004	224490560R2 or 224550560R2	UDZ5.6B or UDZS5.6B
D7005-D7008	223234R2 or 223269R2	1SS352 or 1SS355
D7009	224490910R2 or 224550910R2	UDZ9.1B or UDZS9.1B
D7010	223234R2 or 223269R2	1SS352 or 1SS355
	Coils	
L7001-L7003	231237K220R2	NCH-1477
	Oscillators	
X1001	3010203 or 3010345	AF6146CG or HQS-3H2-04332-20 <PP>
X7001	3010242	CS5.00MGW
	Capacitors	
C1001	355780229	2.2uF,50V, Elect. <PP>
C1003	355721019	100uF,6.3V, Elect. <PP>
C7001	355780229	2.2uF,50V, Elect.
C7002	3000120	FMCOH104Z
C7004,C7005,C700	355721019	100uF,6.3V, Elect.
C7009,C7010	355780109	1uF,50V, Elect.
C7015	355741009	10uF,16V, Elect.
C7018,C7019	355721019	100uF,6.3V, Elect.
C7020	375524744	MMT50V-474J

CIRCUIT NO. PART NO. DESCRIPTION

CIRCUIT NO.	PART NO.	DESCRIPTION
	Switches	
S7101-S7107	25035652	NPS-111-S604
S7111,S7112	25035652	NPS-111-S604
S7113	25035652	NPS-111-S604 <494>
S7114-S7117	25035652	NPS-111-S604
S7121-S7127	25035652	NPS-111-S604
S7131-S7135	25035652	NPS-111-S604
	Sockets	
JL7001A	25051107	NSCT-3P894
JL7003A	25051109	NSCTT-5P896 <494>
P504	2009990580UUL	NSAS-12P0789 <494>
P7001B	25052034 or 25050965 or 25051291 or 25051832 or 25052221	NSCT-25P1821 or NSCT-25P752 or NSCTT-25P1080 or NSCT-25P1619 or NSCT-25P2118
P702A	25052066 or 25050926 or 25051324 or 25051864 or 25052253	NSCT-20P1853 or NSCT-20P713 or NSCT-20P1113 or NSCT-20P1651 or NSCT-20P2150
P7206	2009990573UUL 2009990574UUL	NSAS-4P0782 <DD,PP,PA,GT,490> NSAS-6P0783 <WR,WT>
	Holder	
Q7004A	27190989A	(FL)

U8

MAIN PC BOARD
(NAAR-7044-1A/1B/1C/1D/1F)

CIRCUIT NO.	PART NO.	DESCRIPTION
	ICs	
Q261	22241383R2	NJM4565M-D <494>
Q931	222780565JRC	NJM78M56FA
Q934	222780055	78M05HF
Q3151	22241221R2	TC9164AF
Q3301,Q3501	22241383R2	NJM4565M-D
	Transistors	
Q221,Q222	2215024	2SD1468S-R
Q223	2213510 or 2214350 or 2215770	DTA114ES or RN2202 or KRA102M
Q225	2215864 or 2212115 or 2213284	KTC3199-GR or 2SC2458-GR or 2SC1740S-R <PP>
Q932	2215975 2211455	KTA1266-GR 2SA1015-GR
	Diodes	
D901	22380285F or 22380022F	RS403M or RBV402
D931	224490620R2 or 224550620R2	UDZ6.2B or UDZS6.2B

PRINTED CIRCUIT BOARD PARTS LIST-4

NOTE: <DD> : 120V model only <494>: TX-DS494 only
 <DT> : Asian model only for 120V <490>: HT-R490 only
 <GT> : Asian model only for 230V
 <PP> : European model only
 <PA> : Australian model only
 <WT> : World wide model only
 <WR> : Chinese model only

CIRCUIT NO.	PART NO.	DESCRIPTION
D932	223234R2 or 223269R2	1SS352 or 1SS355
D933-D938	22380260 or 22380032 or 22380035	RL1N4003 or 1SR139-100 or GP104003E
D939	224493000R2	UDZ30B
D940,D941	22380260 or Capacitors	RL1N4003 or 10uF,16V, Elect. 3.3uF,50V, Elect. 2.2uF,50V, Elect.
C222	354741009	10uF,16V, Elect. <494>
C223,C226	354780339	3.3uF,50V, Elect. <494>
C224	354780229	2.2uF,50V, Elect. <494>
C267,C268	354741009	100uF,6.3V, Elect. <494>
C269,C270	354721019	100uF,6.3V, Elect. <494>
C273,C274	374728224	8200pF+/-5%, 50V, Plastic <494>
C275,C276	374721824	1800pF+/-5%, 50V, Plastic <494>
C277,C278	354744709	47uF,16V, Elect. <494>
C279,C280	354741009	10uF,16V, Elect. <494>
C3101,C3201	354784709	47uF,50V, Elect.
C3151,C3152	354744709	47uF,16V, Elect.
C3307,C3308	354741009	10uF,16V, Elect.
C923	3504213S	4700uF,35V, Elect.
C924	354761029S	1000uF,35V, Elect.
C933	354742229S	2200uF,16V, Elect.
C935,C944	354741009	10uF,16V, Elect.
C936,C937	354762219	220uF,35V, Elect.
	Resistors	
R921-R924	453532294	0.22ohm+/-5%, 1/2W, Metal oxide
R925	453530274	2.7ohm+/-5%, 1/2W, Metal oxide
R932	453530224	2.2ohm+/-5%, 1/2W, Metal oxide
R933	453530104	1ohm+/-5%, 1/2W, Metal oxide
R934	443522204	22ohm+/-5%, 1/2W, Metal oxide
R941	443520824	8.2ohm+/-5%, 1/2W, Metal oxide
	Jacks	
P261	25045333	NPJ-2PDBL185 <490>
P261	25045575 or 25045303	NPJ-4PDRW389 or NPJ-4PDBL162 <494>
	Sockets	
JL7001B	25050280	NSCT-3P108
JL911B	25050267	NSCT-3P95
JL912A	25051108	NSCT-4P895
JL921A	25051109	NSCT-5P896
JL931A,JL961A	25051107	NSCT-3P894
P101A	25052024 or 25050955 or 25051281 or 25051822 or 25052211	NSCT-15P1811 or NSCT-15P742 or NSCT-15P1070 or NSCT-15P1609 or NSCT-15P2108
P242A	25055705	NPLG-9P661
P303A,P305A	25055805	NPLG-16P761
P304A,P707A	25055804	NPLG-4P760
P306A,P706A	25055701	NPLG-5P657
P403	20022290820	NSAS-8P0854
P504B	2002E280630	NSAS-06P0904 <490>
P520	25052138	NSCT-7P2036
P704A	25055708	NPLG-12P664
P705A	25055712	NPLG-20P668
	Radiator	
Q934A	27160145	RAD-51
	Screw	
Q934B	82143010	3P+10FN(BC)

NOTE: THE COMPONENTS IDENTIFIED BY MARK  ARE CRITICAL FOR RISK OF FIRE AND ELECTRIC SHOCK. REPLACE ONLY WITH PART NUMBER SPECIFIED.

U9**HEAD PHONE JACK PC BOARD
(NAETC-7045-1A/1B/1C/1D/1F)**

CIRCUIT NO.	PART NO.	DESCRIPTION
	Jack	
P7003	25045514	YKB26-5005, Phones <494>
	Holder	
JL7003B	25051109	NSCT-5P896 <494>

U10**MASTER VOLUME PC BOARD
(NAETC-7046-1A/1B/1C/1D/1F)**

CIRCUIT NO.	PART NO.	DESCRIPTION
	Rotary encoder	
S7001	25065575	EC16B2425
	Sockets	
P7001A	25050931 or 25051329	NSCT-25P718 or NSCT-25P1118

U11**TONE CONTROL PC BOARD
(NAETC-7047-1A/1B/1C/1D/1F)**

CIRCUIT NO.	PART NO.	DESCRIPTION
	Capacitors	
C391,C392	374721534	0.015uF+/-5%, 50V, Plastic
	Resistors	
R391,R392	5104356 or 5132435	N14RLC100KW20Z or N14RGLC100KW20Z, Bass/Treble
	Plug	
P391A	25055139	NPLG-9P123

U12**HOLDER PC BOARD
(NAETC-7048-1A/1B/1C/1D/1F)**

CIRCUIT NO.	PART NO.	DESCRIPTION
	Holders	
P798,P799	27190540-1	HOLDER(CLAMP)

U13**DSP CIRCUIT PC BOARD
(NADG-7049-1A/1B/1C)**

CIRCUIT NO.	PART NO.	DESCRIPTION
	ICs	
Q203	22240373	BA7625
Q701	22241338R2	AK4110VF
Q703	22240935R2	TC7WU04FU
Q704	22241716R9	CS492604-CL
Q705,Q706	22274574ER2TO	TC74VHC574FT
Q707	22241590R3 or 22241591R3 or 22241592R3	MX23C2000-90-001 or MX27C2000(TX-DS494) or MX29F002T(TX-DS494)
Q708	222740077R2TO	TC74HCT7007AF
Q709	22278033ENE	MPC29M33HF
Q711	22241546R2	TC7WT241FU
Q801	22241341R3	AK4526A-VQ
Q802	22240981R2	TC9162AF
Q803-Q809	22241383R2 or 22240581R2	NJM4565M-D or NJM4565M
	Transistors	
Q201,Q204	2214373R2 or 2214374R2 or 2214375R2 or 2216183R2 or 2216184R2 or 2216185R2	2SA1162-O or 2SA1162-Y or 2SA1162-GR or KTA1504-O or KTA1504-Y or KTA1504-GR

PRINTED CIRCUIT BOARD PARTS LIST-5

NOTE: <DD> : 120V model only <494>: TX-DS494 only
 <DT> : Asian model only for 120V <490>: HT-R490 only
 <GT> : Asian model only for 230V
 <PP> : European model only
 <PA> : Australian model only
 <WT> : World wide model only
 <WR> : Chinese model only

NOTE: THE COMPONENTS IDENTIFIED BY MARK  ARE CRITICAL FOR RISK OF FIRE AND ELECTRIC SHOCK. REPLACE ONLY WITH PART NUMBER SPECIFIED.

CIRCUIT NO.	PART NO.	DESCRIPTION
-------------	----------	-------------

Q202,Q3690	2215410R2	RN1441
Q3691	2214540R2	RN2403
	Diodes	
D201,D202	223234R2 or 223269R2	1SS352 or 1SS355
D801-D808	223234R2 or 223269R2	1SS352 or 1SS355
	Coils	
L201	231237M022R2	NCH-1471
L701-L703	231237M022R2	NCH-1471
L704,L705	230921R2	BLM21B222SPT,Choke coil
L720-L722	231237M022R2	NCH-1471
L802,L803	231237M022R2	NCH-1471
	Oscillator	
X701	3010327 or 3010320 or 3010335	AT-4912.288MHz or AT-49 12.288MHz or AT-49H12.288MHz,Crystal
X702	3010324R2	CSTCV12.2MTJ0C4,Cera lock
	Capacitors	
C201-C203	354780229	2.2uF,50V, Elect.
C205,C206	354724719	470uF,6.3V, Elect.
C210,C701,C708	354721019	100uF,6.3V, Elect.
C3691	374721044	0.1uF+/-5%, 50V, Plastic
C740,C741	354721019	100uF,6.3V, Elect.
C788,C791	354724719	470uF,6.3V, Elect.
C807,C810	354721019	100uF,6.3V, Elect.
C811,C825	354741009	10uF,16V, Elect.
C816,C817	374721524	1500pF+/-5%, 50V, Plastic
C827,C829	354744709	47uF,16V, Elect.
C830,C831	354784709	47uF,50V, Elect.
C832	374721544	0.15uF+/-5%, 50V, Plastic
C833,C846,C847	374721524	1500pF+/-5%, 50V, Plastic
C834,C836	374726834	0.068uF+/-5%, 50V, Plastic
C835,C837	374726814	680pF+/-5%, 50V, Plastic
C840,C842	354744709	47uF,16V, Elect.
C844,C845	354784709	47uF,50V, Elect.
C848-C851	374726814	680pF+/-5%, 50V, Plastic
C854,C857,C868	354744709	47uF,16V, Elect.
C858,C859	354784709	47uF,50V, Elect.
C860,C861	374721524	1500pF+/-5%, 50V, Plastic
C862-C865	374726814	680pF+/-5%, 50V, Plastic
C871 ,C880,C882	354744709	47uF,16V, Elect.
C886	374721034	0.01uF+/-5%, 50V, Plastic
C894,C896	354744709	47uF,16V, Elect.
	Jacks	
P201	25045567	NPJ-1PDBL382
P202	25045315	NPJ-2PDYE172
P203	25045299	NPJ-3PDYE158
	Sockets	
P702B	25052029 or 25050960 or 25051286 or 25051827 or 25052216	NSCT-20P1816 or NSCT-20P747 or NSCT-20P1075 or NSCT-20P1614 or NSCT-20P2113
P704	25051237	NSCT-12P1027
P705	25051241	NSCT-20P1031
P706	25051230	NSCT-5P1020
P707	25051526	NSCT-4P1313
	Plug	
P701A	25055136	NPLG-6P120

U14		
INPUT TERMINAL PC BOARD (NAAF-7050-1A/1B/1C/1D/1F/1G/1H)		
CIRCUIT NO.	PART NO.	DESCRIPTION

	ICs	
Q301	22240864	TC9273N-004
Q302,Q3181,Q3183	22241383R2	NJM4565M-D
Q3171	22241371	TC9482N
Q3281,Q3381,Q3581	22241383R2	NJM4565M-D
	Transistors	
Q3182,Q3184	2213632 or 2213631	RN1241-B or RN1241-A
Q3185	2214350 or 2213510 or 2215770	RN2202 or DTA114ES or KRA102M
Q3282,Q3284	2213632 or 2213631	RN1241-B or RN1241-A
Q3384,Q3484	2213632 or 2213631	RN1241-B or RN1241-A
Q3584,Q3684,Q3685	2213631 or 2213632	RN1241-A or RN1241-B
	Diodes	
D401,D402,D3182	223234R2 or 223269R2	1SS352 or 1SS355
	Capacitors	
C315,C316	354744709	47uF,16V, Elect.
C3171,C3271	354781009	10uF,50V, Elect.
C3172,C3173	354744709	47uF,16V, Elect.
C3181,C3281	354782209	22uF,50V, Elect.
C3183,C3188	354744709	47uF,16V, Elect.
C3189,C3289	374721534	0.015uF+/-5%,50V, Plastic
C3190,C3196	354741009	10uF,16V, Elect.
C3194,C3195	354744709	47uF,16V, Elect.
C321,C322	354784709	47uF,50V, Elect.
C323,C324	354744709	47uF,16V, Elect.
C3283,C3288	354744709	47uF,16V, Elect.
C3290,C3394,C3395	354741009	10uF,16V, Elect.
C3371,C3381	354781009	10uF,50V, Elect.
C3388,C3488	354744709	47uF,16V, Elect.
C3471,C3481	354781009	10uF,50V, Elect.
C3571,C3581	354781009	10uF,50V, Elect.
C3588,C3688	354744709	47uF,16V, Elect.
C3594,C3595	354741009	10uF,16V, Elect.
C3671,C3681	354781009	10uF,50V, Elect.
C3687	374724734	0.047uF+/-5%,50V, Plastic
	Jacks	
P301,P302	25045300 or 25045571	NPJ-6PDBL159 or NPJ-6PDRW386
P7202	25045645	NPJ-2PDO450 <494>
	Sockets	
P303,P305	25051527	NSCT-16P1314
P304	25051526	NSCT-4P1313
P306	25051230	NSCT-5P1020
P391	2009990579UL	NSAS-16P0788
P601	2009990652UL	NSAS-10P0907

PRINTED CIRCUIT BOARD PARTS LIST-6

NOTE: <DD> : 120V model only <494>: TX-DS494 only
 <DT> : Asian model only for 120V <490>: HT-R490 only
 <GT> : Asian model only for 230V
 <PP> : European model only
 <PA> : Australian model only
 <WT> : World wide model only
 <WR> : Chinese model only

NOTE: THE COMPONENTS IDENTIFIED BY MARK \triangle ARE
 CRITICAL FOR RISK OF FIRE AND ELECTRIC SHOCK.
 REPLACE ONLY WITH PART NUMBER SPECIFIED.

U15**PRIMARY CIRCUIT PC BOARD**

(NAPS-7051-1A/1B/1C/1D/1F/1G/1H)

CIRCUIT NO.	PART NO.	DESCRIPTION
Q951	Transistor	
	2213640 or 2215830	DTC123JS or KRC105M
D951	Diodes	
	22380260 or 22380032 or 22380035	RL1N4003 or 1SR139-100 or GP104003E <PP,PA,WT,GT,WR>
	22380260 or 22380032 or 22380035	RL1N4003 or 1SR139-100 or GP104003E
D952	22380260 or 22380032 or 22380035	RL1N4003 or 1SR139-100 or GP104003E
D953,D954	22380260 or 22380032 or 22380035	RL1N4003 or 1SR139-100 or GP104003E <PP,PA,WT,GT,WR>
D955	223234R2 or 223269R2	1SS352 or 1SS355
T902	Transformer	
	2301381	\triangle NPT-1358D <DD,490>
	2301382 2301383	\triangle NPT-1358P <PP,PA> \triangle NPT-1358DG <WT,GT,WR>
C902 C952	Capacitors	
	3500196S 354753319	\triangle RE275V-103M 330uF,25V, Elect.
R901 R951	Resistors	
	431533355 453530824	\triangle RC1/2GFKUL-3.3M <DD,490> 8.2ohm+/-5%, 1/2W, Metal oxide <PP PA WT GT WR>
RL901	Relay	
	25065561 or 25065515 or 25065526	\triangle NRL-1P5A-DC12-127 or \triangle NRL-1P5A-DC12-096 or \triangle NRL-1P5A-DC12-102
	Switch	
S902	25065437	\triangle NSS-22157P <WT,WR>
JL961B P903	Sockets	
	25050267	NSCT-3P95
	25051125	\triangle NSCT-4P912 <PP,WT,GT>
	25051126	\triangle NSCT-4P913 <DD,490>
	25052115 25052381	\triangle NSCT-2P2013 <PA> \triangle NSCT-2P2278 <WR>
P901A	Plugs	
	25056028 or 25055675	\triangle NPLG-2P0978 or \triangle NPLG-2P631
F911B,F911A	Fuse holders	
	25052133 or 25052609	\triangle NSCT-1P2031 or \triangle NSCT-1P2506
F922A,F922B	25052133 or 25052609	\triangle NSCT-1P2031 or \triangle NSCT-1P2506 <DD,WT,490,WR>

U16**POWER SWITCH PC BOARD**

(NASW-7052-1B/1B/1C/1D/1F/1G/1H)

CIRCUIT NO.	PART NO.	DESCRIPTION
C901	Capacitor	
	3500196S	\triangle RE275V-103M
S901	Switch	
	25035550	\triangle NPS-111-L512P, Power

U19**REGULATOR CIRCUIT PC BOARD**

(NAPS-7055-1A/1B/1C/1D/1F/1G/1H)

CIRCUIT NO.	PART NO.	DESCRIPTION
C926-C928,C942	394541007	10uF,16V, Elect.
JL921B	25050269	NSCT-5P97
JL931B	25050267	NSCT-3P95
R926	452630564F	5.6ohm+/-5%, 1W, Metal oxide
R929	441623304F	33ohm+/-5%, 1W, Metal oxide
R938	453530104	1ohm+/-5%, 1W, Metal oxide

U20**VIDEO TERMINAL PC BOARD**

(NAETC-7056-1A/1B/1C/1D/1F/1G/1H)

CIRCUIT NO.	PART NO.	DESCRIPTION
Q401,Q402	ICs	
	22240373	BA7625
Q403,Q404	Transistor	
	2214375R2 or 2216185R2	2SA1162-GR or KTA1504-GR
Q405,Q406	Capacitors	
	2215410R2	RN1441
C401,C411,C412 C402 C421,C422 C431,C432 C443,C444	Capacitors	
	354780229	2.2uF,50V, Elect.
	354724719	470uF,6.3V, Elect.
	354780229	2.2uF,50V, Elect.
R409,R410	Resistors	
	354780229 354721019	2.2uF,50V, Elect. <494> 100uF,6.3V, Elect.
P401 P401,P402 P403A	Sockets	
	443521014 25051568 25051748 25055442	100ohm+/-5%, 1/2W, Metal oxide NSCT-12P1355 <490> NSCT-8P1535 <494> NPLG-4P424

U21**MULTI CHANNEL INPUT TERMINAL PC BOARD**

(NAAF-7057-1A/1B/1C/1D/1F/1G/1H)

CIRCUIT NO.	PART NO.	DESCRIPTION
Q341,Q343 Q7201	ICs	
	22240293 222740046R2O	NJM4558L-D TC74HCU04F
L7201,L7202 L7203 L7204 U7201	Coils	
	231237K470R2	NCH-1479
	231237M022R2	NCH-1471 <494>
	231237M022R2	NCH-1471
C7203,C7205 C347,C348	Capacitors	
	24120095	TORX179
P242B P341	Sockets	
	354721019 354741009	100uF,6.3V, Elect. 10uF,16V, Elect.
P701 P7202	Sockets	
	25051234 25045649 or 25045572	NSCT-9P1024 NPJ-6PDBRW453 or NPJ-6PDBRW387
F933A,F933B	Sockets	
	2009990577UL 25045473 25052133 or 25052609	NSAS-12P0786 NPJ-1PDBL291 <490> NSCT-1P2031 or NSCT-1P2506 <PP>

FL TUBE VIEW
Q7004: 15-BT-80GNK

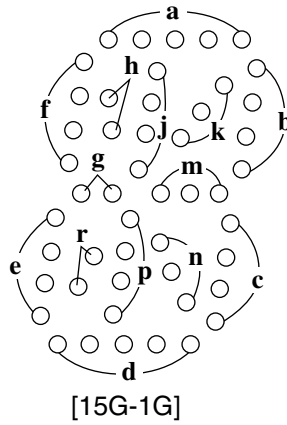
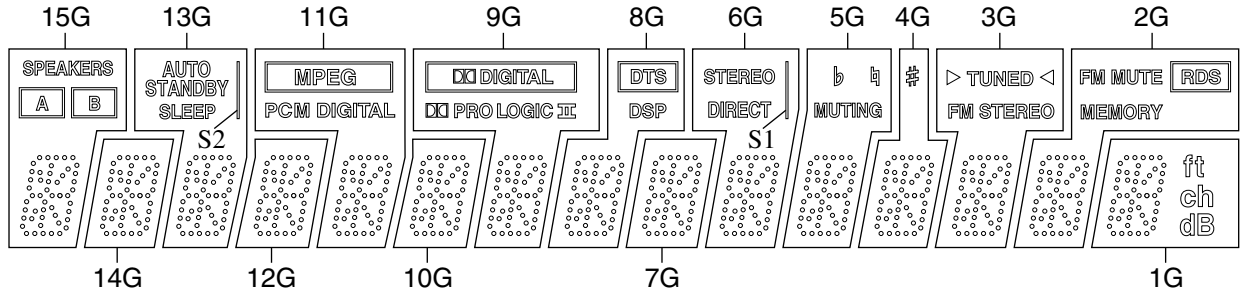

[15G-1G]

	P1	P2	P3	P4	P5	P6	P7	P8	P9	P10	P11	P12	P13	P14	P15	P16	P17	
1G	dB	ch	ft	a	h	j	k	b	f	m	g	c	e	r	p	n	d	
2G	RDS	FM MUTE	MEMORY	a	h	j	k	b	f	m	g	c	e	r	p	n	d	
3G	TUNED	>	<	FM STEREO	a	h	j	k	b	f	m	g	c	e	r	p	n	d
4G	#	—	—	a	h	j	k	b	f	m	g	c	e	r	p	n	d	
5G	b	b	MUTING	a	h	j	k	b	f	m	g	c	e	r	p	n	d	
6G	STEREO	DIRECT	S1	a	h	j	k	b	f	m	g	c	e	r	p	n	d	
7G	—	—	—	a	h	j	k	b	f	m	g	c	e	r	p	n	d	
8G	DTS	DTS	DSP	a	h	j	k	b	f	m	g	c	e	r	p	n	d	
9G	DIGITAL	DIGITAL	PRO LOGIC II	a	h	j	k	b	f	m	g	c	e	r	p	n	d	
10G	—	—	—	a	h	j	k	b	f	m	g	c	e	r	p	n	d	
11G	MPEG	MPEG	PCM DIGITAL	a	h	j	k	b	f	m	g	c	e	r	p	n	d	
12G	—	—	—	a	h	j	k	b	f	m	g	c	e	r	p	n	d	
13G	AUTO STANDBY	SLEEP	S2	a	h	j	k	b	f	m	g	c	e	r	p	n	d	
14G	—	—	—	a	h	j	k	b	f	m	g	c	e	r	p	n	d	
15G	SPEAKERS	A	B	a	h	j	k	b	f	m	g	c	e	r	p	n	d	

ADJUSTMENT PROCEDURES

IDLING CURRENT ADJUSTMENT

1. Before Idling adjustment, turn the trimming resistors R573, R574, R673, R674 and R1532 to counter clockwise.
2. Connect the DC voltmeter to sockets P511, P512, P611, P612 and P1511.
3. After turn POWER to ON, adjust the trimming resistors R573, R574, R673, R674 and R1532 so that the reading of voltmeter becomes 2.4 to 2.6 mV.
4. After adjustment, attach the top cover.
5. Confirm the voltage of above points after five minutes.
6. When 3.1 mV to 6.4 mV : Readjust the trimming resistors above so that the voltage becomes 6.5 to 6.7 mV.
When 6.5 mV to 7.5 mV : It is not necessary to adjust.
When 7.6 mV to 13 mV : Readjust the trimming resistors above so that the voltage becomes 7.5 to 7.7 mV.

[Note] No load and No signal

Front Lch

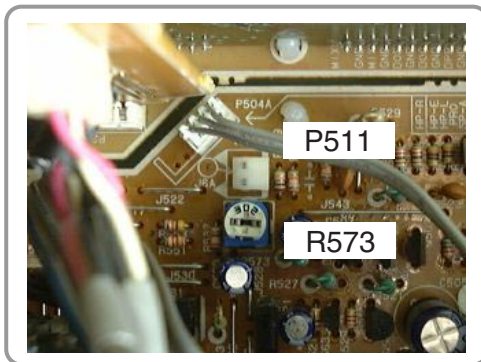

Front Rch

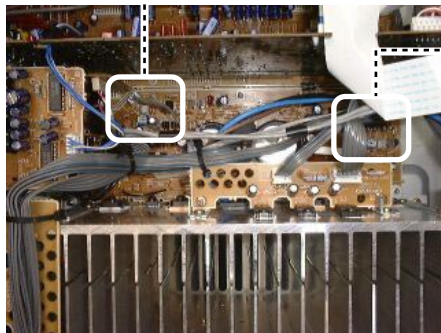
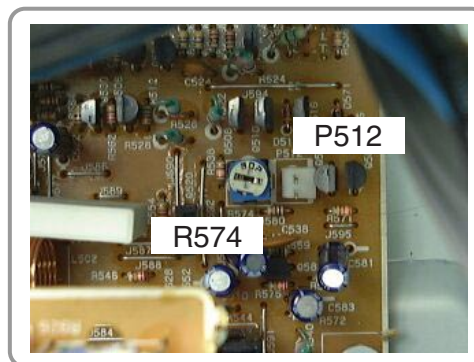

→ Front side

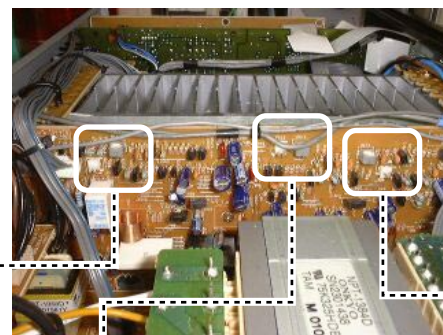

→ Front side

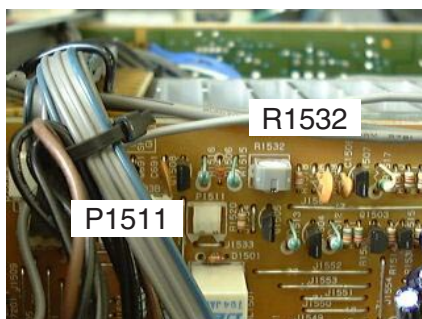

Center ch

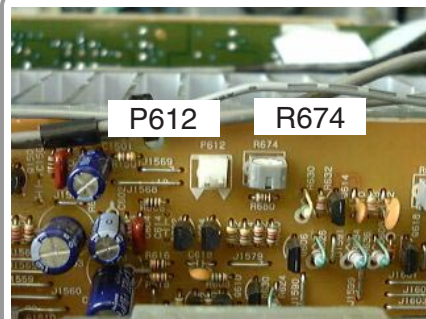

Surround Rch

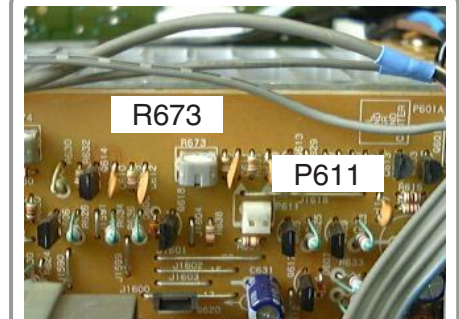

Surround Lch

CONFIRMATION

CONFIRMATION OF PROTECTION CIRCUIT

1. Confirmation of speaker relay

Confirm that the speaker relay turns ON approximate 5 seconds after the power switch is turned ON.

Confirm that the speaker relay turns OFF immediately after the power switch is turned OFF.

2. Confirmation of DC detection circuit

1. Press and hold down CD button, then press SPEAKERS A and SPEAKERS B buttons at the same time.

2. Press DVD button, while "TEST-1_" on the FLtube is displayed.

During "TEST-1-00" on the FL tube is displayed.

3. Press SPEAKERS A button button

During "TEST-1-01" on the FL tube is displayed.

4. Apply DC 1.5~3V to MULTI CHANNEL INPUT terminals with no load.

Confirm that the speaker relay turns OFF.

5. Apply DC -1.5~3V to MULTI CHANNEL INPUT terminals with no load.

Confirm that the speaker relay turns OFF.

3. Confirmation of Current detection circuit

1. Press and hold down CD button, then press SPEAKERS A and SPEAKERS B buttons at the same time.

2. Press DVD button, while "TEST-1_" on the FLtube is displayed.

During "TEST-1-00" on the FL tube is displayed.

3. Press SPEAKERS A button button

During "TEST-1-01" on the FL tube is displayed.

4. Connect Differentiator below and apply the 50Hz square signal to the MULTI CHANNEL INPUT terminals.

5. Adjust the attenuator or Volume so that the output level becomes 35V p-p.

6. Confirm that the speaker relay does not turn OFF when a 3.0 ohm load is connected.

7. Confirm that the speaker relay turns OFF when a 1.0 ohm load is connected.

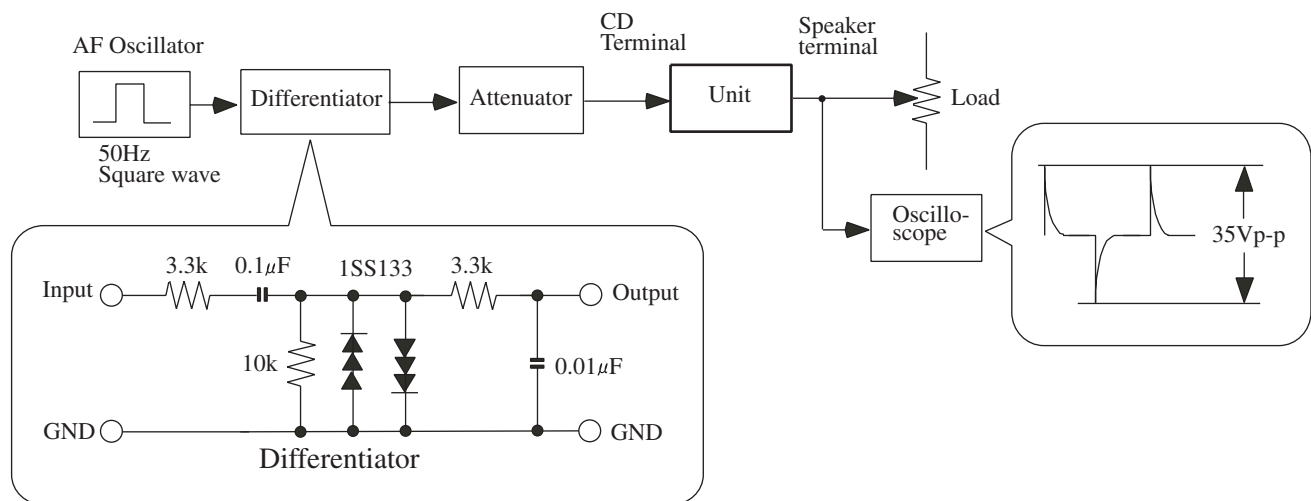

PACKING VIEW

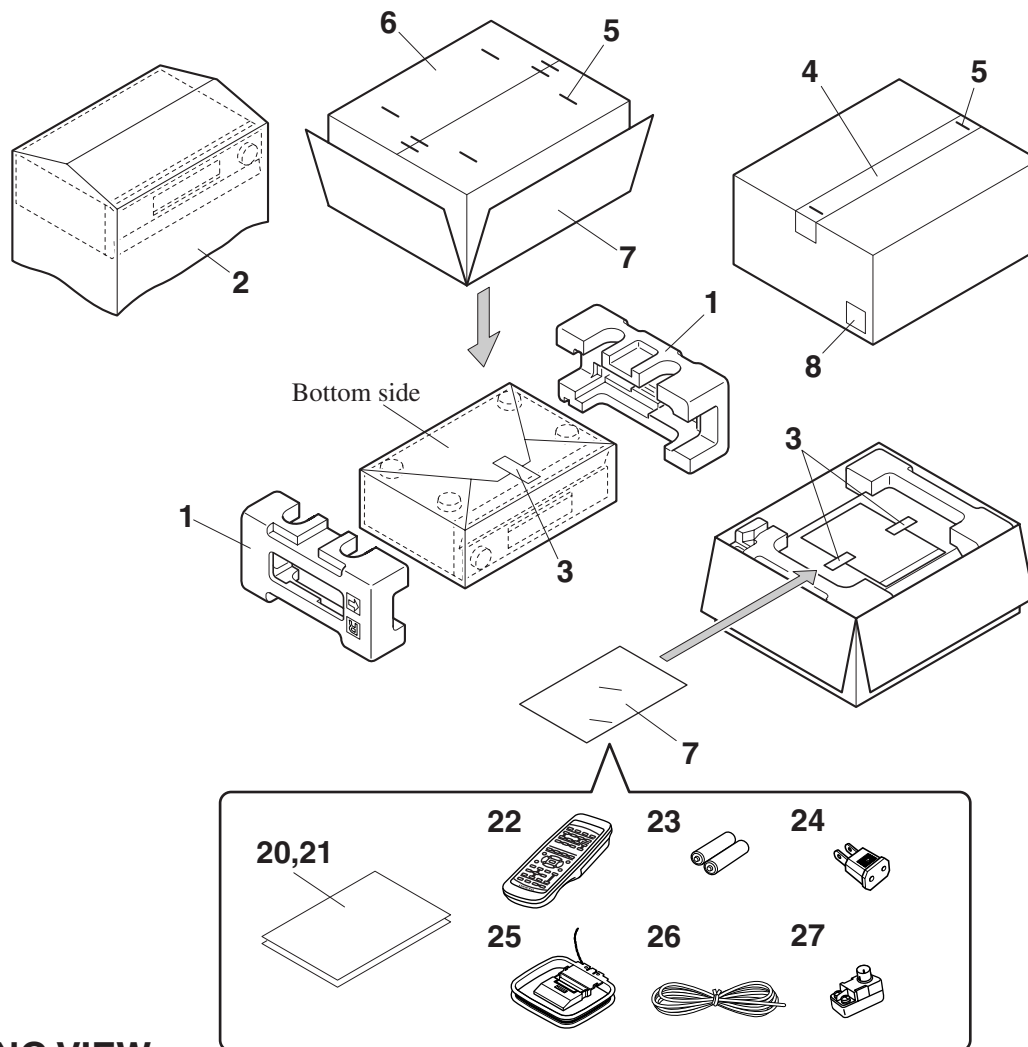

PACKING VIEW

REF. NO.	PART NO.	DESCRIPTION	REF. NO.	PART NO.	DESCRIPTION
1	29091972B	Pad AS	21	29365090	Warranty card <DD,490>
2	29100034-1A	Polybag, 585 x 650		29365042	Warranty card <PA>
3	261504	Paper tape, W30	22	24140444	RC-444M, Remote controller <DD>
4	29110098	PP Tape		24140443	RC-443M, Remote controller <PP, WT, WR, PA>
5	282301	Staple		24140446	RC-446M, Remote controller <490>
6	29100097-1A	Polybag, 350 x 250	23	3010054	UM-3, Battery
7	29053700A	Carton box <DD>	24	25055018 or	
	29053701A	Carton box <S> <PP>		25056005	CV plug, CV-K-1 <WT>
	29053702A	Carton box <WT, WR>	25	232140	AM Loop antenna, NMA-3057
	29053703A	Carton box <PP>	26	292115	FM antenna <PP,WR,WT,PA,GT>
	29053704A	Carton box <G> <PA,WT,WR>		292142	FM antenna <DD,490>
	29053706A	Carton box <490>	27	25065462	FM Antenna adapter YAE21-0237 <WT,WR,PA>
8	29362794	Label, UPC <DD>			
	29362795	Label EAN <PP, WT, WR, PA>			
	29362796	Label EAN <S> <PP>			
	29362797	Label EAN <G> <PA, WR, WT>			
	29362808	Label EAN <490>			
20	29343037	Instruction manual E <DD,PP,WT,WR,GT,PA>			
	29343046	Instruction manual E <490>			
	29343038	Instruction manual DIG-E <DD>			
	29343047	Instruction manual DIG-E <490>			
	29343039	Instruction manual U3GDSw <PP>			
	29343050	Instruction manual U2CTCS <WT, WR, GT>			
	29343040	Instruction manual U3FSI <PP>			

[NOTE]

- <DD> : 120V model only
- <DT> : Asian model only for 120V
- <GT> : Asian model only for 230V
- <PP> : European model only
- <WT> : World wide model only
- <WR> : Chinese model only
- <494> : TX-DS494 only
- <490> : HT-R490 only
- : Black model only
- <S> : Silver model only
- <G> : Golden model only

ONKYO CORPORATION

Sales & Product Planning Div. : 2-1, Nisshin-cho, Neyagawa-shi, OSAKA 572-8540, JAPAN
Tel: 072-831-8111 Fax: 072-833-5222

ONKYO U.S.A. CORPORATION

18 Park Way, Upper Saddle River, N.J. 07458, U.S.A.
Tel: 201-785-2600 Fax: 201-785-2650 E-mail: onkyo@onkyousa.com

ONKYO EUROPE ELECTRONICS GmbH

Industriestrasse 20, 82110 Germering, GERMANY
Tel: 089-849-320 Fax: 089-849-3265 E-mail: info@onkyo.de

ONKYO CHINA LIMITED

Units 2102-2107, Metroplaza Tower I, 223 Hing Fong Road, Kwai Chung,
N.T., HONG KONG Tel: 852-2429-3118 Fax: 852-2428-9039