

# ONKYO SERVICE MANUAL

## AV RECEIVER MODEL HT-R500

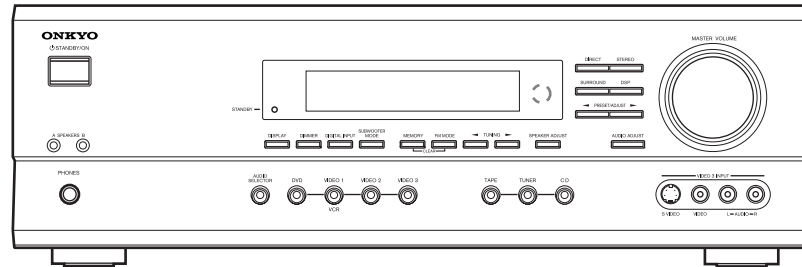

### Black models

BMDD	120V AC, 60Hz
------	---------------

### SAFETY-RELATED COMPONENT WARNING!!

COMPONENTS IDENTIFIED BY MARK  $\triangle$  ON THE SCHEMATIC DIAGRAM AND IN THE PARTS LIST ARE CRITICAL FOR RISK OF FIRE AND ELECTRIC SHOCK. REPLACE THESE COMPONENTS WITH ONKYO PARTS WHOSE PART NUMBERS APPEAR AS SHOWN IN THIS MANUAL.

MAKE LEAKAGE-CURRENT OR RESISTANCE MEASUREMENTS TO DETERMINE THAT EXPOSED PARTS ARE ACCEPTABLY INSULATED FROM THE SUPPLY CIRCUIT BEFORE RETURNING THE APPLIANCE TO THE CUSTOMER.

## SERVICE PROCEDURES

### 1. Replacing the fuses



This symbol located near the fuses indicates that the fuse used is fast operating type. For continued protection against fire hazard, replace with same type fuse. For fuse rating refer to the marking adjacent to the symbol.



Ce symbole indique que le fusible utilise est a rapide. Pour une protection permanente, n'utiliser que fusibles de meme type. Ce dernier est la qu le present symbol est appse.

CIRCUIT NO.	PART NO.	DESCRIPTION
F6901,	252198 or	8A-UL or
F6902	252261	8A-T/UL-ST2,Fuse
F901	252198 or	8A-UL or
	252261	8A-T/UL-ST2,Fuse

### 2. To initialize the unit

This device employs a microprocessor to perform various functions and operations. If interference generated by an external power supply, radio wave, or other electrical source results in accident which causes the specified operations and functions to operate abnormally.

To perform a result, please follow the procedure below.

- 1.Press and hold down the VIDEO-1 button, then press the STANDBY/ON button.
- 2.After "clear" is displayed, the preset memory and each mode stored in the memory, such as surround, are initialized and will return to the factory setting.

### 3. Safety-check out

(Only U.S.A. model)

After correcting the original service problem, perform the following safety check before releasing the set to the customer. Connect the insulating-resistance tester between the plug of power supply cord and screw on the back panel.

Specifications: 3.3Mohm+/-10% at 500V.

### 4. Memory Preservation

This unit does not require memory preservation batteries. A built-in memory power back-up system preserves the contents of the memory during power failures and even when the unit is unplugged.The unit must be plugged in order to charge the back-up system.

The memory preservation period after the unit has been unplugged varies depending on climate and placement of the unit. On the average, memory contents are protected over a period of a few weeks after the last time the unit has been unplugged.This period is shorter when the unit is exposed to a highly humid climate.



## EXPLODED VIEW

### PARTS LIST

CAUTION: Replacement for transistor of mark \*, if necessary must be made from the same beta group (hFE) as the original type.

REF.NO.	PART NO.	DESCRIPTION	REF.NO.	PART NO.	DESCRIPTION
1	27111268	Front bracket	P901	253332HIT or AS-UC-2 or 253333VOL AS-UC-2,Power supply cord	
2	838130088	3TTB+8B,Self-tapping screw	Q6050~	2203563, * KTC5242-O,	
5	27100416	Chassis	Q6054	2202842, * 2SC5242-R,	
6	27190503A	KGLS-8RF,Holder		2202843, * 2SC5242-O,	
7	27190813	KGPS-10RF,Holder		2203562, * KTC5242-R,	
8	27190428A	KGLS-10RF,Holder		2203663, * MN130S-O,	
9	830440089	4TTC+8C(BC),Self-tapping screw		2203664 or * MN130S-Y or	
10	880009	NRP-345,Plastic rivet		2203666 * MN130S-P,Transistor	
11	27300750	Bushing,cord	Q6060~	2203553, * KTA1962-O,	
12	27160511	Heat sink	Q6064	2202832, * 2SA1962-R,	
13	801433	3SMS8W.SW+14B(BC),Special screw		2202833, * 2SA1962-O,	
16	28184831	Top cover		2203552, * KTA1962-R,	
17	838430088	3TTB+8B(BC),Self-tapping screw		2203673, * MP130S-O,	
21	27175319B	Leg		2203674 or * MP130S-Y or	
22	28141494	Cushion		2203676 * MP130S-P,Transistor	
23	838130088	3TTB+8B,Self-tapping screw	T901	2301624  NPT-1446D,Power transformer	
24	28325641	Knob, volume	U1	1A928501-1F NADG-7401-1F,DSP circuit PC board ass'y	
25	28191957	Clear plate	U3	1A928503-1A NADIS-7403-1A,Display circuit PC board ass'y	
31	27122989A	Rear panel	U4	1A928504-1A NASW-7404-1A,Standby switch PC board ass'y	
33	838430088	3TTB+8B(BC),Self-tapping screw	U5	1A928505-1A NAETC-7405-1A,Headphone terminal PC board ass'y	
51	27212402	Front panel	U6	1A928506-1A NAETC-7406-1A,Front video PC board ass'y	
52	28135244	Badge	U7	1A928507-1A NAETC-7407-1A,Connector PC board ass'y	
53	838430088	3TTB+8B(BC),Self-tapping screw	U9	1A928509-2A NAAF-7409-2A, Power amplifier driver PC board ass'y	
54	29110083	Tape cloth	U10	1A928510-2A NAETC-7410-2A,Regulator PC board ass'y	
55	223024	AC238,Isolated plate	U11	1A928511-2A NAETC-7411-2A,Secondary PC board ass'y	
56	260208	Wire tie	U12	1A928512-2A NAETC-7412-2A,Speaker terminal PC board ass'y	
F6901,	252198 or	8A-UL or	U13	1A928513-2A NAETC-7413-2A,PC board for holder	
F6902	252261	8A-T/UL-ST2,Fuse	U17	1A928517-2A NAAF-7417-2A,Power amplifier PC board ass'y	
F901	252198 or	8A-UL or	U19	1A928519-2A NAPS-7419-2A,Terminal PC board ass'y	
	252261	8A-T/UL-ST2,Fuse	U20	1A928520-2A NAPS-7420-2A,Primary circuit PC board ass'y	
P101	2047151512	NCFC7-151512,Flexible flat cable	U21	1A928521-2A NAPS-7421-2A,Terminal PC board ass'y	
P7001	2045102012	NCFC5-102012,Flexible flat cable	U22	1A928522-2A NAVD-7422-2A,Video terminal PC board ass'y	
P7503	2047081012	NCFC7-081012,Flexible flat cable	U23	1A928523-2A NAETC-7423-2A,PC board for holder	
			U24	1A928524-2A NAETC-7424-2A,Thermal detector circuit PC board ass'y	
			U31	240138A or ENG06501QR or	
				240134A TFCE1U114B,Tuner unit	

NOTE: THE COMPONENTS IDENTIFIED BY MARK ARE CRITICAL FOR RISK OF FIRE AND ELECTRIC SHOCK. REPLACE ONLY WITH PART NUMBER SPECIFIED.

A B C D

# BLOCK DIAGRAM 1

1  
2  
3  
4  
5

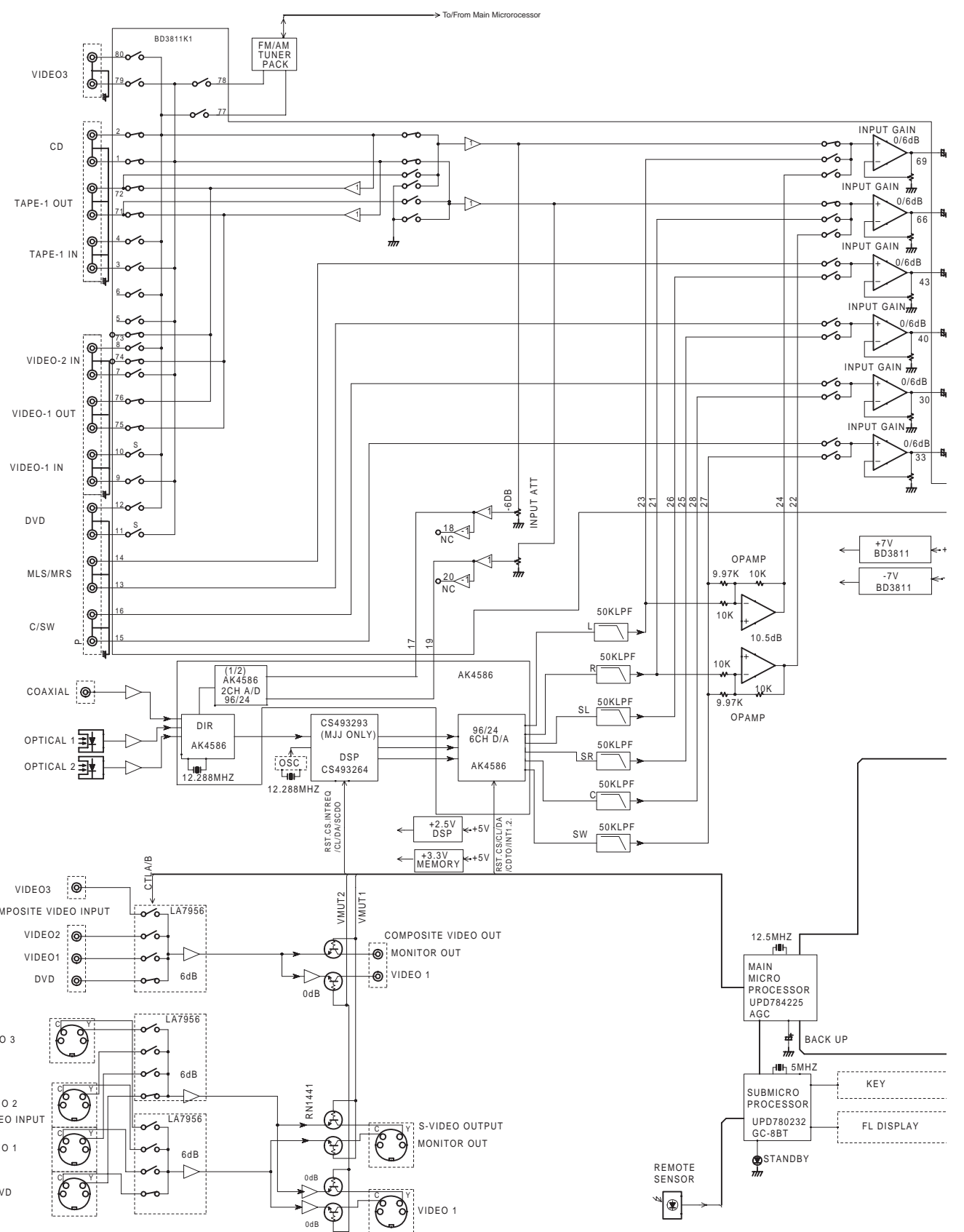

A B C D  
BLOCK DIAGRAM 2

1

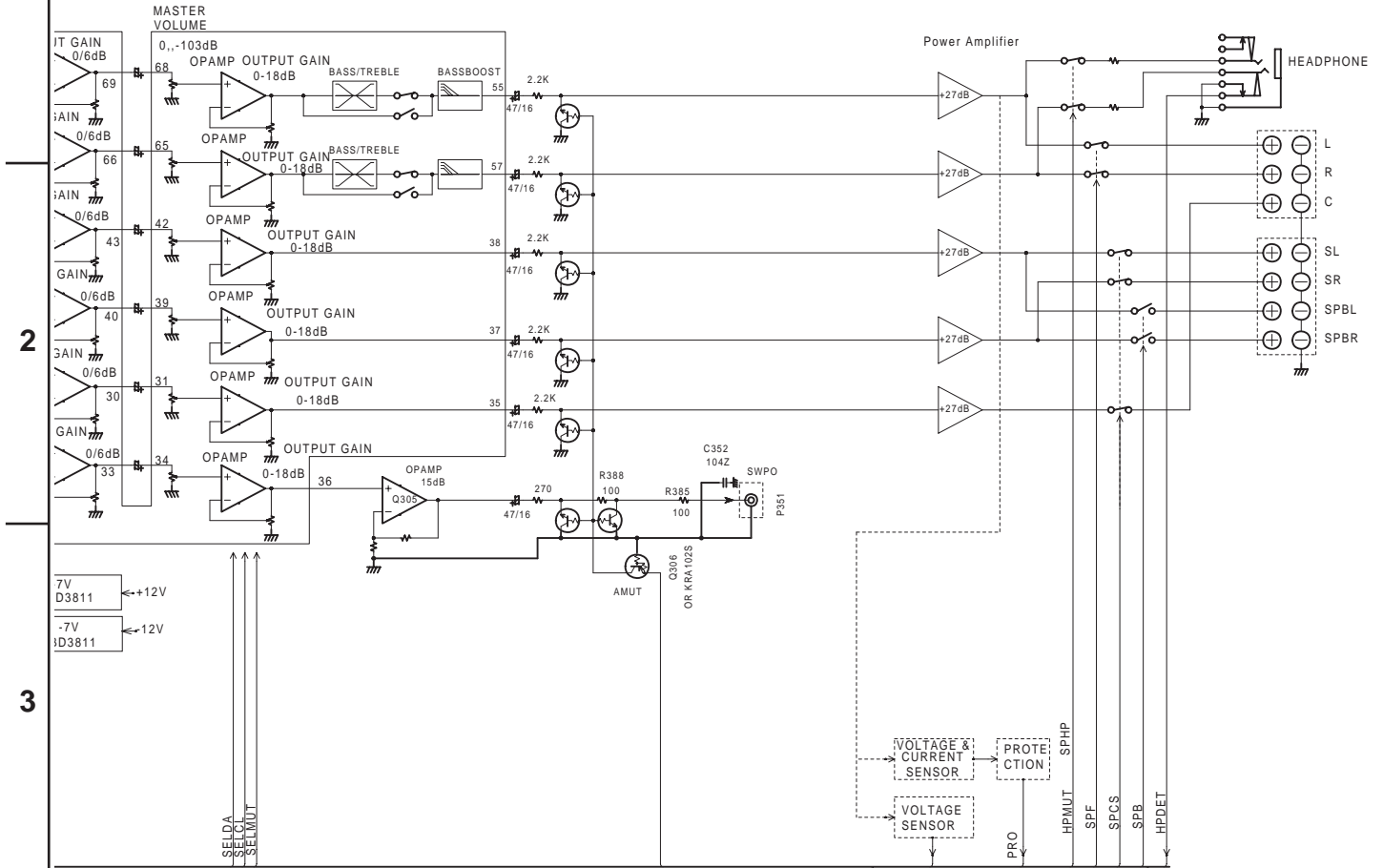

2

3

4

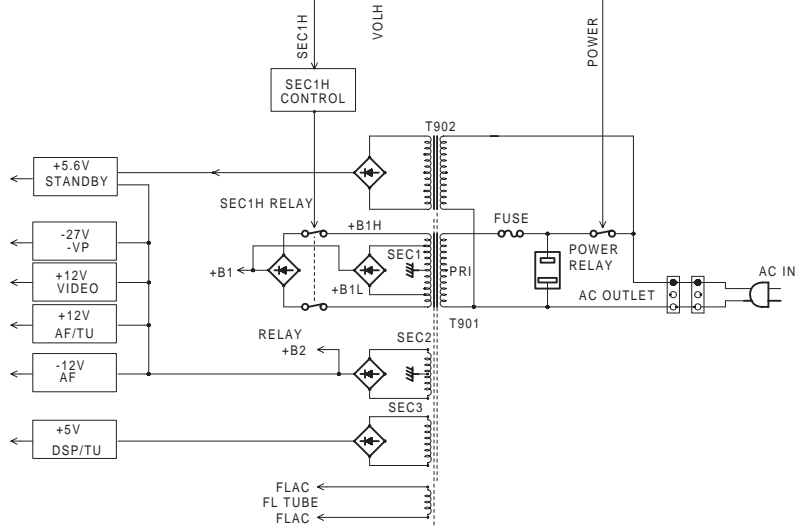

5

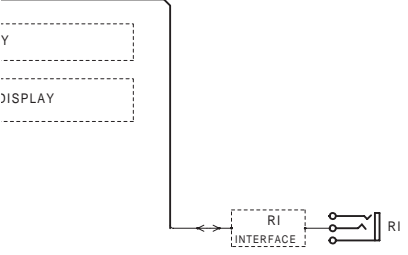







SCHEMATIC DIAGRAM 2-2  
DSP section

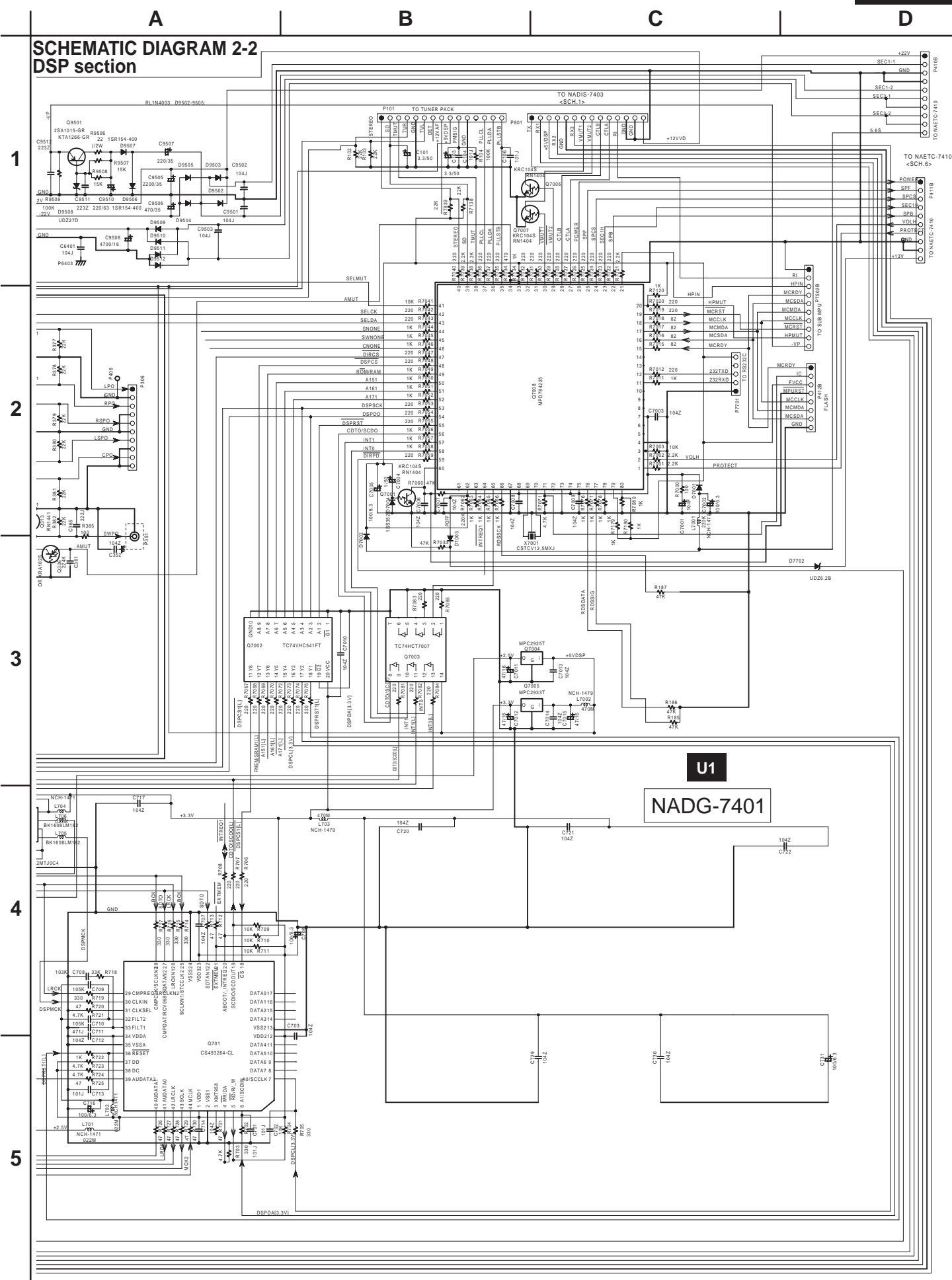

# SCHEMATIC DIAGRAM 3 Video section

1

2

3

4

5

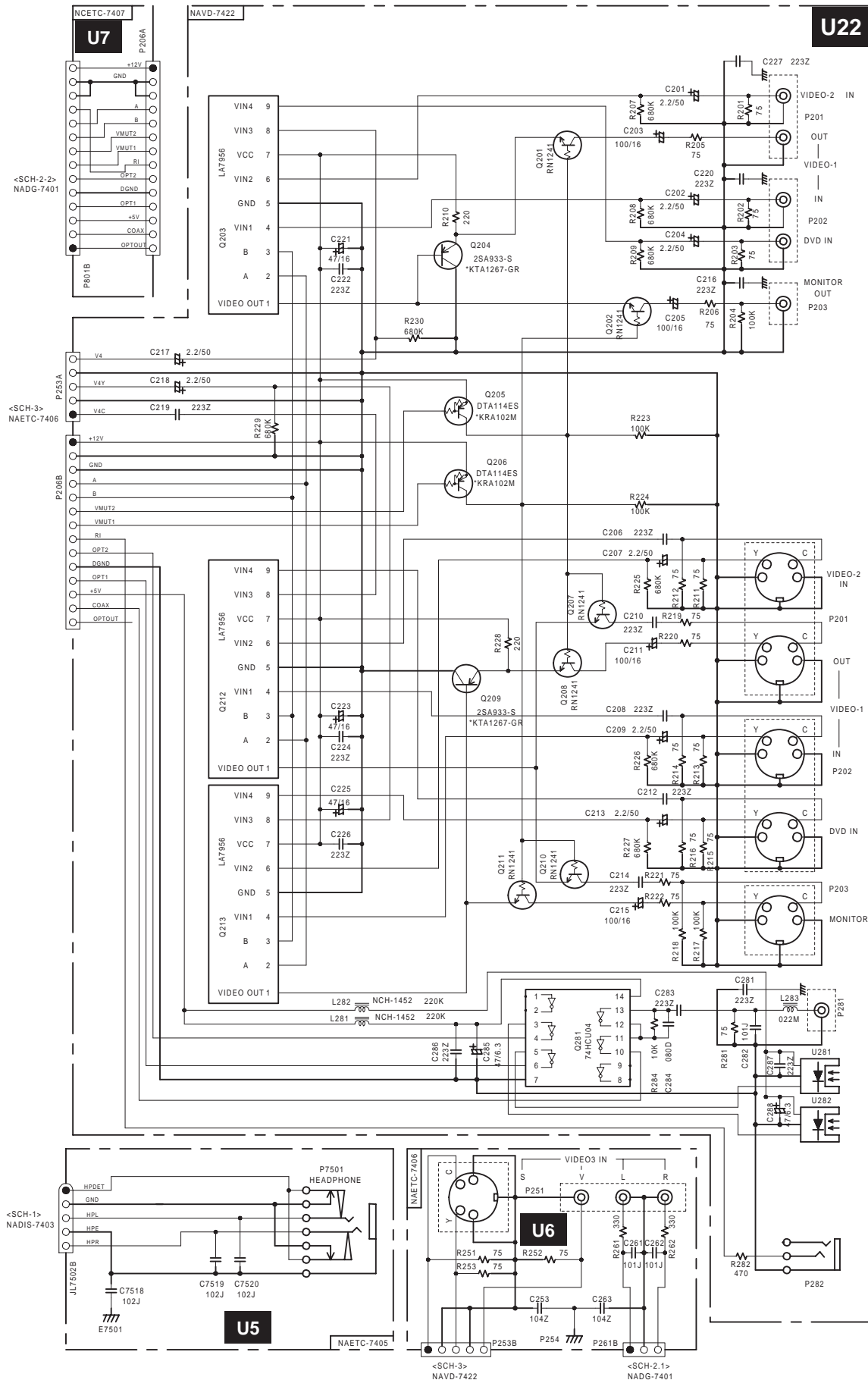

SCHEMATIC DIAGRAM 4-1 Power amplifier section 1

NAAF-7409

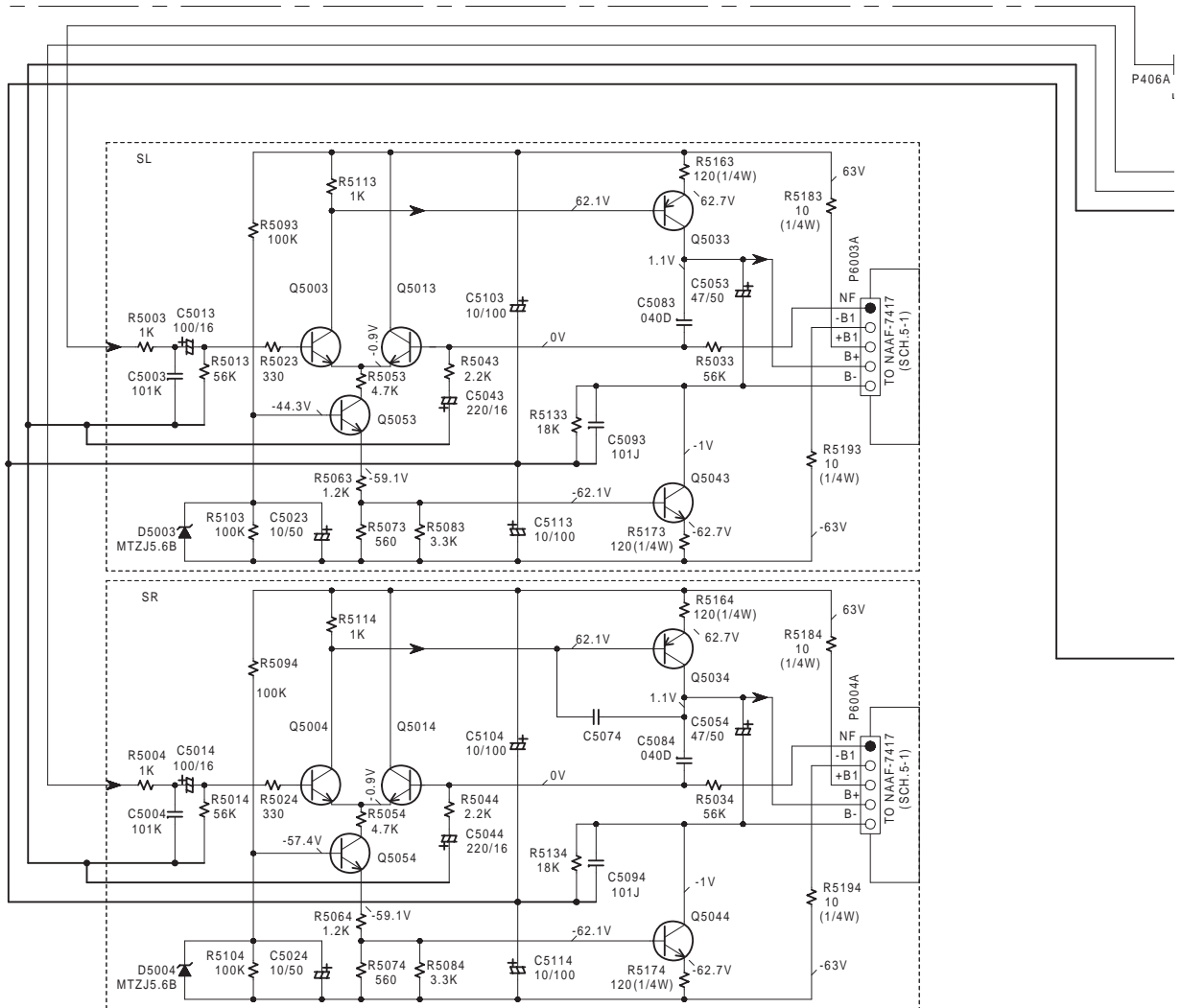

SEMICONDUCTORS

NO.	
Q5000-04,5010-14	KTC3200-BL OR 2SC1775A-E,F OR 2SC1845-E
Q5030-34	KTA1024-Y,O OR 2SA949-Y,O
Q5040-44	KTC3206-Y,O OR 2SC2229-Y,O
Q5050-54	KTC3200-BL,GR OR 2SC1775A-E,F OR 2SC1845-E,F

U9

A B C D

**SCHEMATIC DIAGRAM 4-2**  
Power amplifier section 2

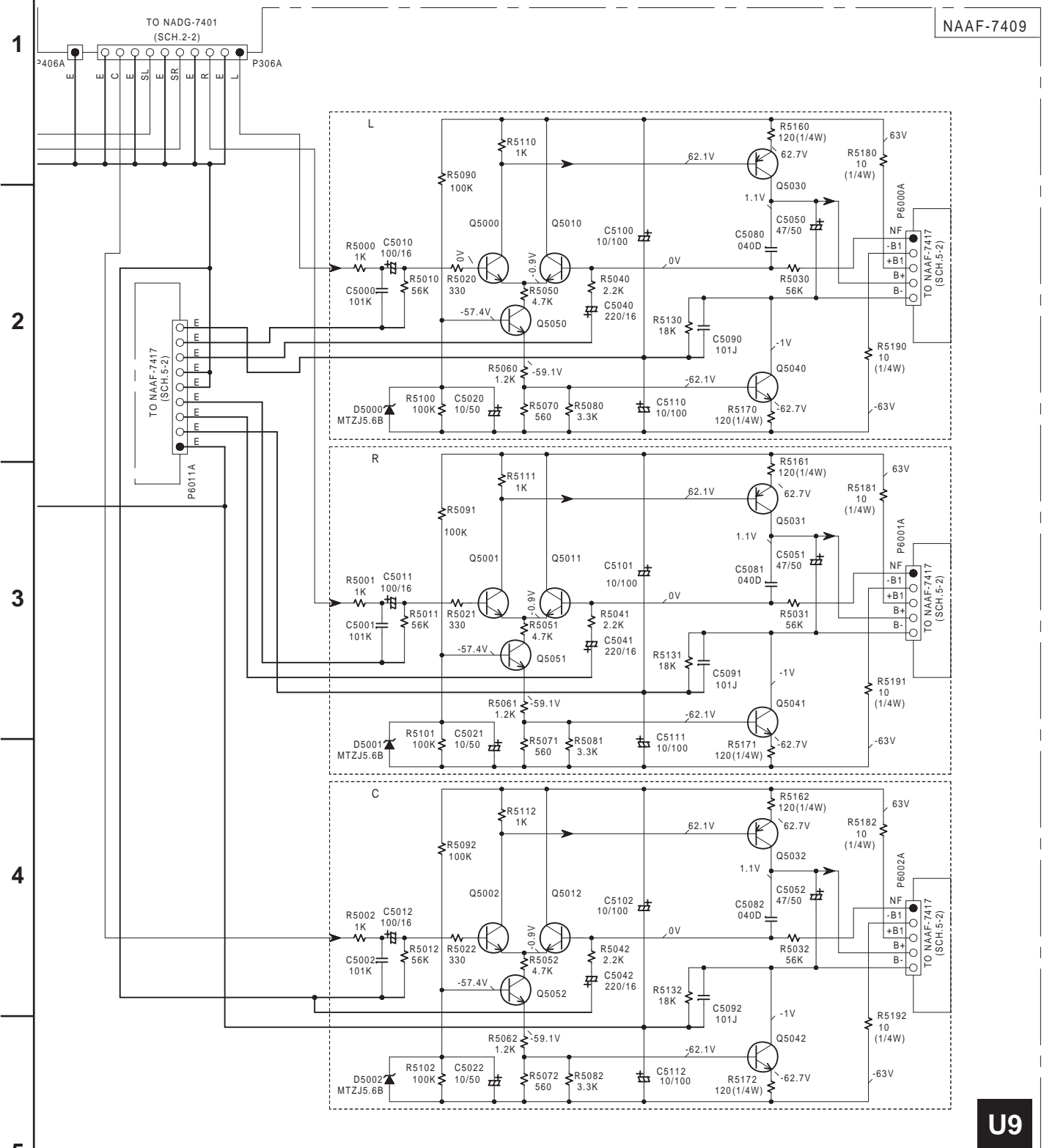

NAAF-7409

U9

SEMICONDUCTORS

NO.	
Q5000-04,5010-14	KTC3200-BL OR 2SC1775A-E,F OR 2SC1845-E
Q5030-34	KTA1024-Y,O OR 2SA949-Y,O
Q5040-44	KTC3206-Y,O OR 2SC2229-Y,O
Q5050-54	KTC3200-BL,GR OR 2SC1775A-E,F OR 2SC1845-E,F







A

B

C

D

# SCHEMATIC DIAGRAM 7

## Speaker terminal section

1

2

3

4

5

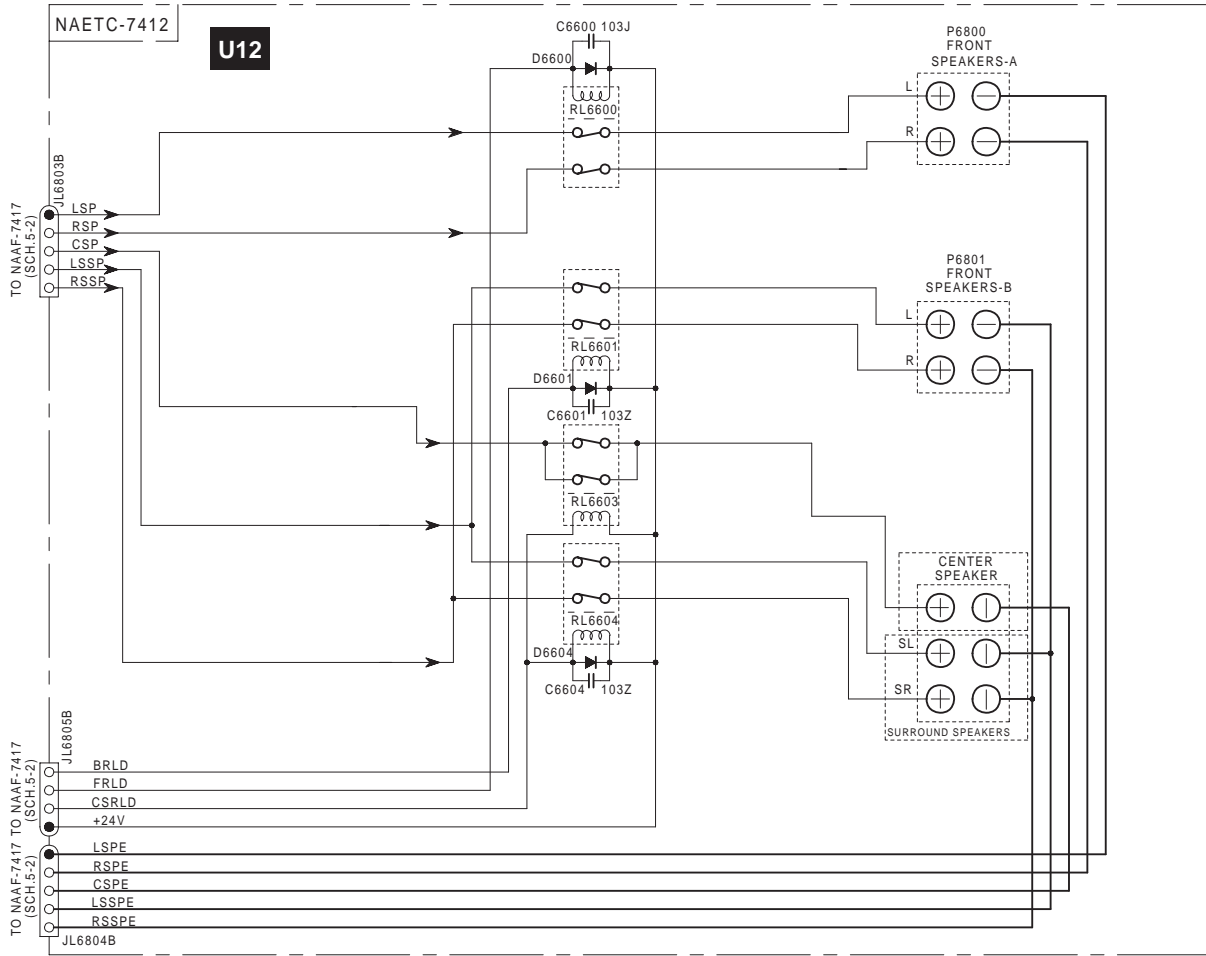





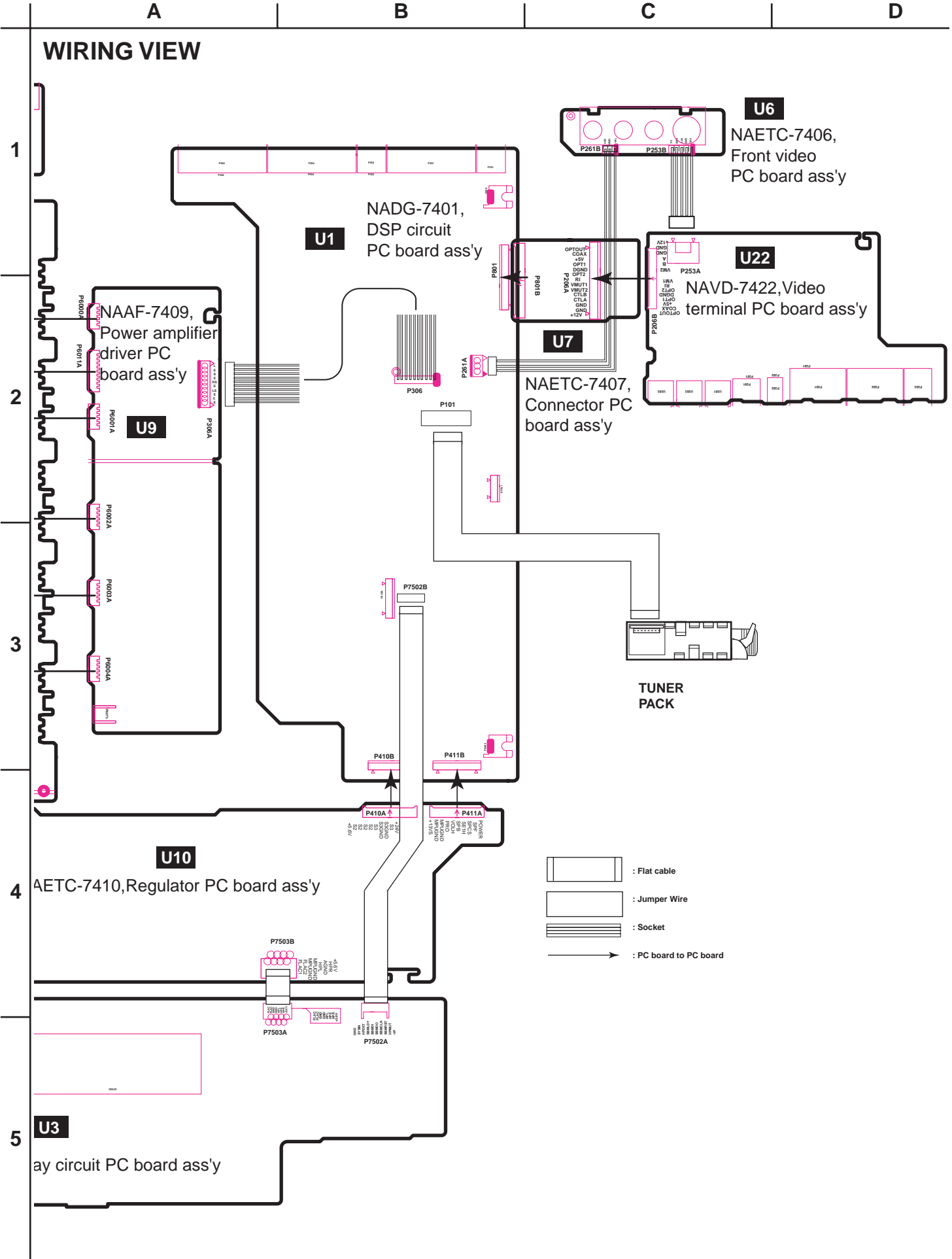



A

B

C

D

PRINTED CIRCUIT BOARD VIEW 1-2 FROM SOLDERING SIDE

**U3** NADIS-7403, Display circuit PC board

**U5** NAETC-7405, Headphone terminal PC board

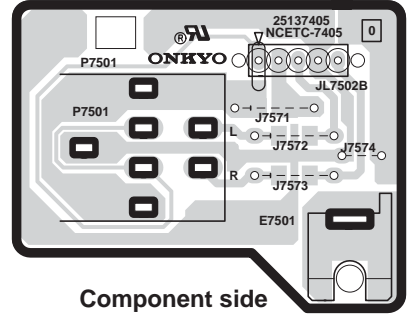
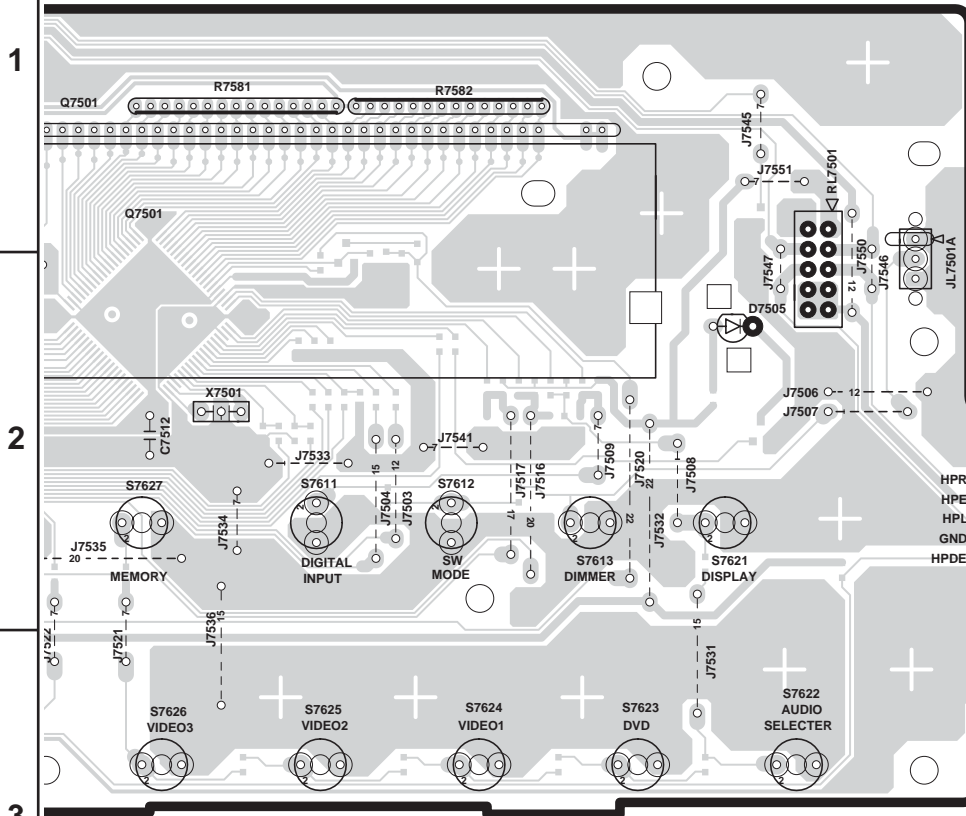

Component side

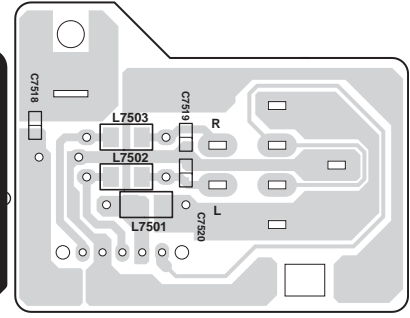

Soldering side

Componet side

**U7** NAETC-7407, Connector PC board

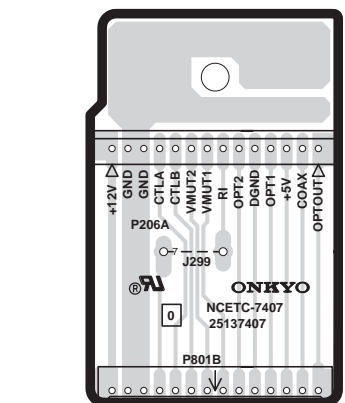
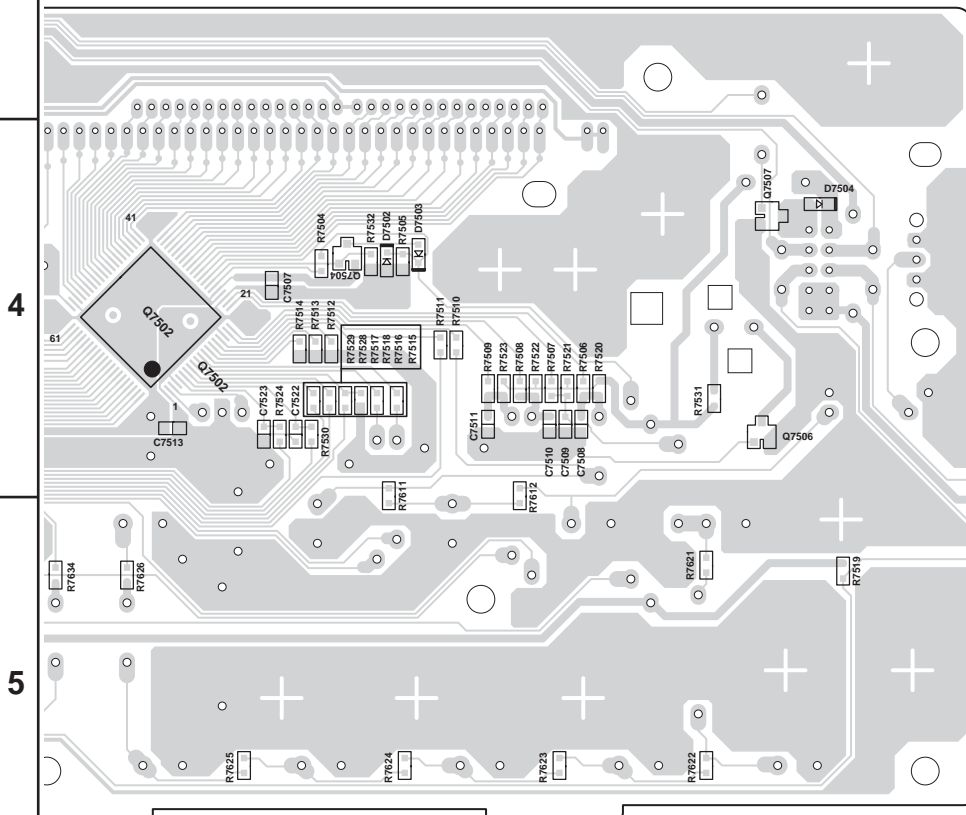

Componet side

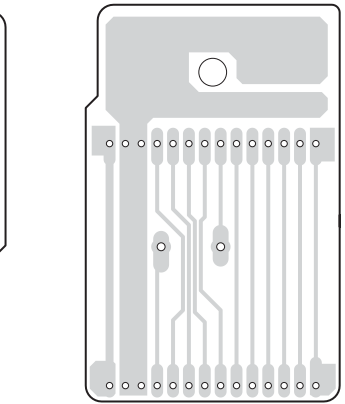

Soldering side

Soldering side

1

2

3

4

5





A

B

C

D

PRINTED CIRCUIT BOARD VIEW 6 FROM SOLDERING SIDE

**U4** NASW-7404, Standby switch PC board

1

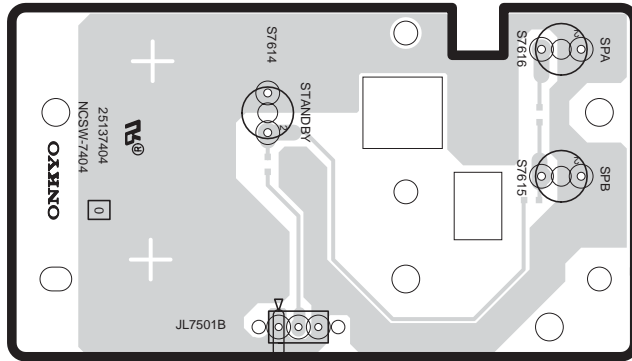

Component side

2

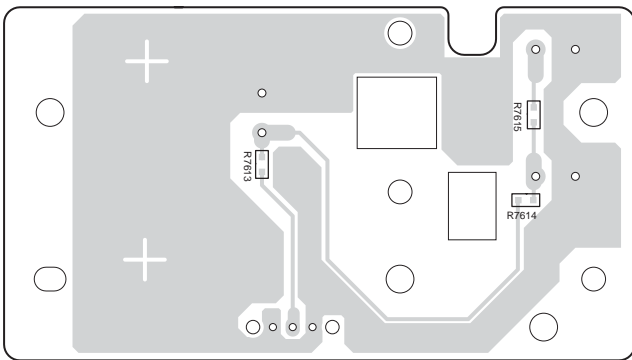

Soldering side

3

**U6** NAETC-7406, Front video PC board

4

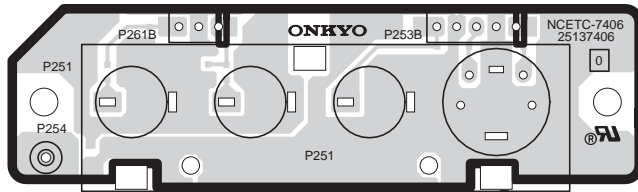

Component side

5

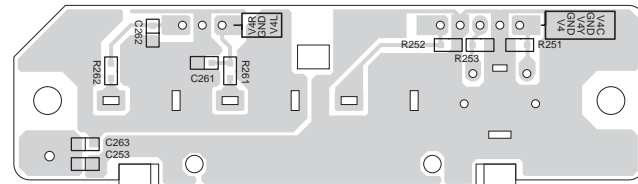

Soldering side







A

B

C

D

PRINTED CIRCUIT BOARD VIEW 5-1 FROM SOLDERING SIDE

1

2

3

4

5

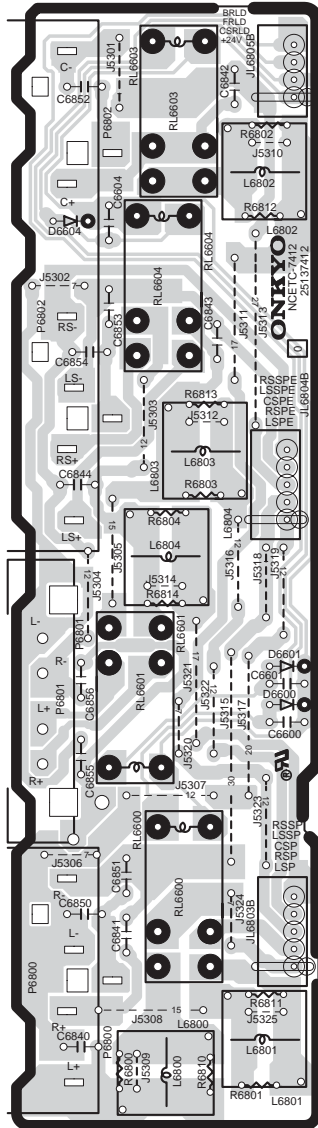

**U12**

NAETC-7412, Speaker terminal PC board

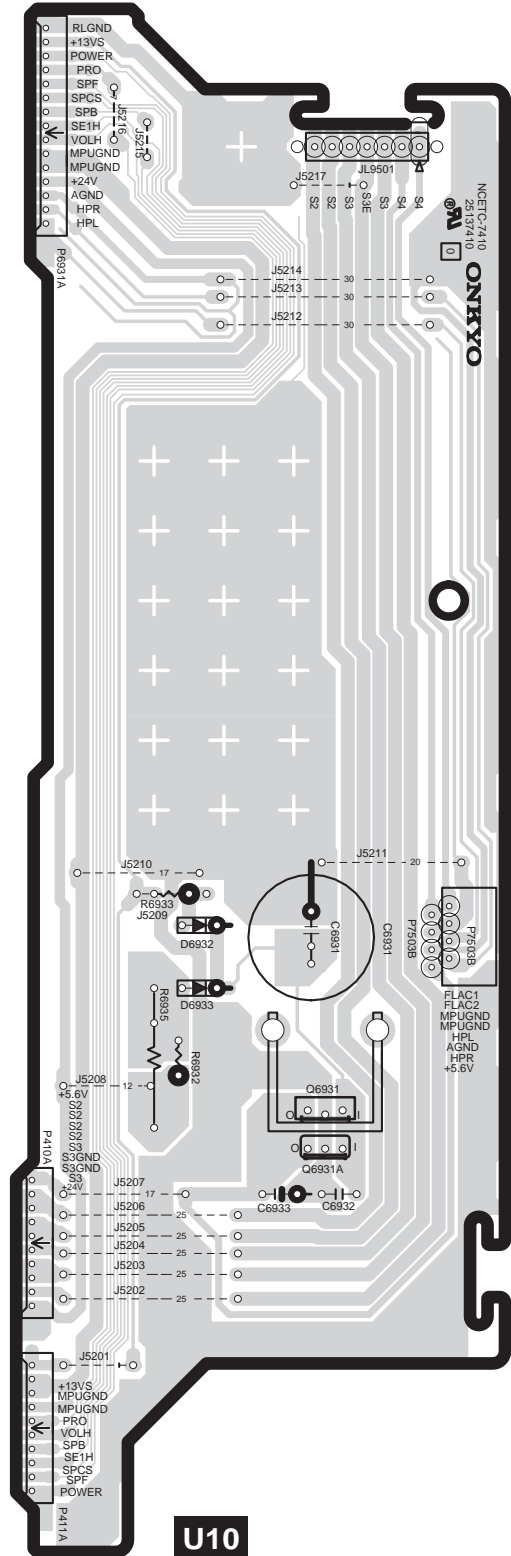

**U10**

NAETC-7410, Regulator PC board

A

B

C

D

PRINTED CIRCUIT BOARD VIEW 5-2 FROM SOLDERING SIDE

1

2

3

4

5

U20

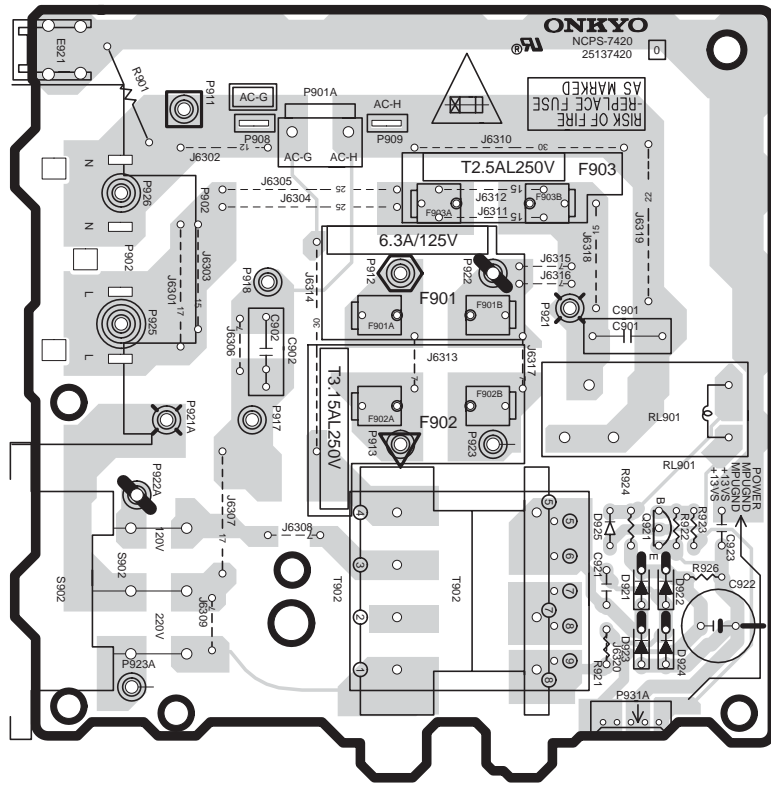

NAPS-7420, Primary circuit PC board

U11

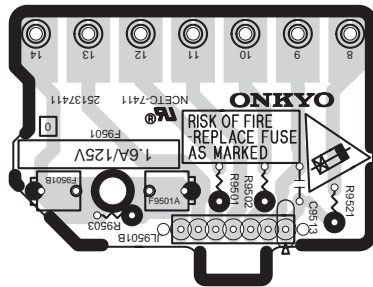

NAETC-7411, Secondary PC board

U21

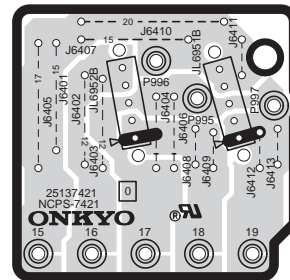

NAPS-7421, Terminal PC board

U19

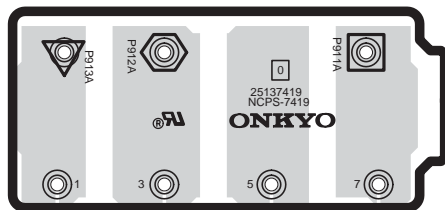

NAPS-7419, Terminal PC board

A

B

C

D

PRINTED CIRCUIT BOARD VIEW 3 FROM SOLDERING SIDE

1

2

3

4

5

U22

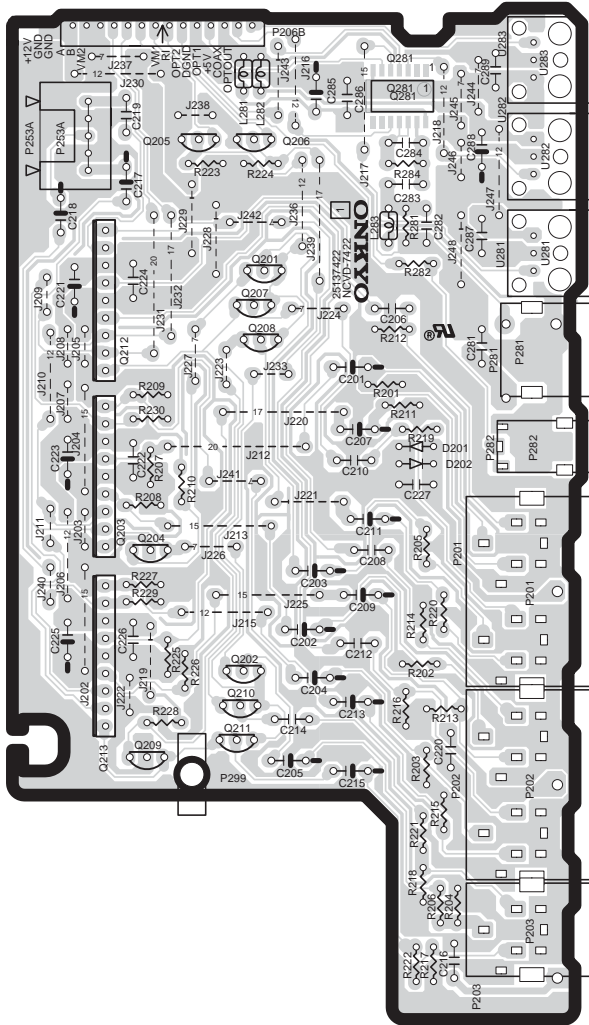

NAVD-7422, Video terminal PC board

U9

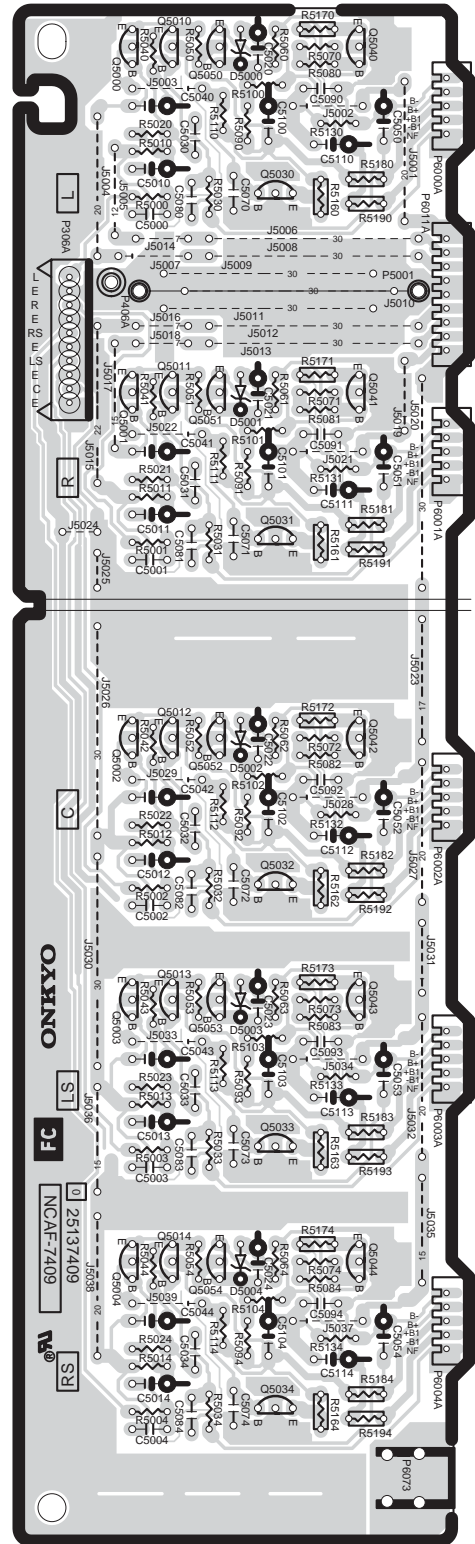

NAAF-7409, Power amplifier driver PC board

## PRINTED CIRCUIT BOARD-PARTS LIST 1

## DSP CIRCUIT PC BOARD(NADG-7401-1F)

CIRCUIT NO.	PART NO.	DESCRIPTION
		<b>ICs</b>
Q301	22241761R3	BD3811K1
Q302,Q305	22241383R2,	NJM4565M-D,
Q802-Q804	22240489R1NE or 22240581R2	MPC4570G2-T1(MST) or NJM4565M
Q321	222780073R2	78L07(SMT)
Q322	222790073R2	79L07(SMT)
Q6402,Q6405	222780125	78M12HF
Q6403	222790125	79M12HF
Q6406	222780055	78M05HF
Q7002	22274541ER2TO or 22274541IR2TI	TC74VHC541FT or SN74AHC541PWR
Q7003	222740077R2TO	TC74HCT7007AF
Q7004	22278025DR2NE or 22278025DR2JR	MPC2925T or NJM2391DL1-25
Q7005	22278033DR2NE or 22278033DR2JR	MPC2933T or NJM2391DL1-33
Q7008	22241881R3 or 22241766R3	MPD784225GC-183-8BT or MPD78F4225 (No spare part)
Q701	22241762R2	CS493264
Q707	22240935R2	TC7WU04FU
Q801	22241620R3	AK4586
		<b>Transistors</b>
Q306	2214530R2 or 2216220R2	RN2402 or KRA102S
Q307,Q308	2215410R2	RN1441
Q312,Q313	2215410R2	RN1441
Q7001	2214490R2 or	RN1404 or
Q7006,Q7007	2216210R2	KRC104S
Q9501	2211455	2SA1015-GR
		<b>Diodes</b>
D7001-D7004	223234R2 or	1SS352 or
D801,D802	223269R2	1SS355
D7702	224660624R2, 224490620R2 or 224550620R2	HZU6.2B, UDZ6.2B or UDZS6.2B
D9502-D9507	22380260,	RL1N4003,
D9509-D9512	22380032 or 22380035	1SR139-100 or GP104003E
D9508	224662704R2, 224492700R2 or 224552700R2	HZU27B, UDZ27B or UDZS27B
		<b>Coils</b>
L7001,L7002	231237K470R2	NCH-1479
L701,L702	231237M022R2	NCH-1471
L703	231237K470R2	NCH-1479
L704	231237M022R2	NCH-1471
L705,L706	230958R1	BK1608LM182-T
L801-L804	231237M022R2	NCH-1471
L805	230958R1	BK1608LM182-T
		<b>Oscillators</b>
X7001	3010361R2	CSTCE12M5G52-R0
X701	3010324R2	CSTCV12.2MTJ0C4
		<b>Capacitors</b>
C101,C103	394680337	3.3uF,50V,Elect.
C300,C301	374721015	100pF+/-10%,50V,Plastic
C329-C334	393341007	10uF,16V,Elect.
C335,C336	373043324R2	3300pF+/-5%,16V,Plastic
C338,C340	373045634R2	0.056uF+/-5%,16V,Plastic
C347,C348	394641017	100uF,16V,Elect.
C349	393341007	10uF,16V,Elect.
C353,C354	393344707	47uF,16V,Elect.
C358	393344707	47uF,16V,Elect.
C359,C362	394641007	10uF,16V,Elect.

CIRCUIT NO.	PART NO.	DESCRIPTION
		<b>Capacitors</b>
C363,C364	393341007	10uF,16V,Elect.
C6401	374721044	0.1uF+/-5%,50V,Plastic
C6404,C6406	394641007	10uF,16V,Elect.
C6410,C6412	394641007	10uF,16V,Elect.
C7001	3000078, 3000120 or 3000121	DX-5R5L104, FMC0H104Z or SCDA5R5104A,Super
C7002,C7005	394621017	100uF,6.3V,Elect.
C7004	394680107	1uF,50V,Elect.
C7011,C7012	394644707	47uF,16V,Elect.
C7015	394644707	47uF,16V,Elect.
C706,C716	394621017	100uF,6.3V,Elect.
C731	394621017	100uF,6.3V,Elect.
C801,C810	394644707	47uF,16V,Elect.
C806	394622217	220uF,6.3V,Elect.
C809	394641007	10uF,16V,Elect.
C832-C837	393341007	10uF,16V,Elect.
C841	373048224R2	8200pF+/-5%,16V,Plastic
C849	373041534R2	0.015uF+/-5%,16V,Plastic
C852,C853	374721524	1500pF+/-5%,50V,Plastic
C854	393341007	10uF,16V,Elect.
C855	393344707	47uF,16V,Elect.
C856-C859	393341007	10uF,16V,Elect.
C9501-C9503	374721044	0.1uF+/-5%,50V,Plastic
C9505	394662227	2200uF,35V,Elect.
C9506	394664717	470uF,35V,Elect.
C9507	394662217	220uF,35V,Elect.
C9508	394644727	4700uF,16V,Elect.
C9510	394672217	220uF,63V,Elect.
		<b>Resistors</b>
R6402	442521004	10ohm+/-5%,1/2W,Metal oxide
R6403	442523304	33ohm+/-5%,1/2W,Metal oxide
R6407	452630334	3.3ohm+/-5%,1W,Metal
R6410	453530224	2.2ohm+/-5%,1/2W,Metal
R9506	443522204	22ohm+/-5%,1/2W,Metal oxide
		<b>Terminals</b>
P301,P304	25045571 or 25045300	NPJ-6PDRW386 or NPJ-6PDBL159
P305	25045572 or 25045649	NPJ-6PDBRW387 or NPJ-6PDBRW453
P351	25045567	NPJ-1PDBL382
		<b>Sockets</b>
P101	25052211 or 25052024	NSCT-15P2108 or NSCT-15P1811
P7502B	25052576R2	NSCT-10P2473
P306	2009990717UL	NSAS-20P1004
		<b>Plugs</b>
P261A	25055133	NPLG-3P117
P410B,P411B	25055706	NPLG-10P662
P801	25055710	NPLG-14P666
		<b>Radiator</b>
Q6402B	27160500	RAD-165
		<b>Screws</b>
Q6402A	82143010	3P+10FN(BC),Pan head
		<b>DISPLAY CIRCUIT PC BOARD(NADIS-7403-1A)</b>
CIRCUIT NO.	PART NO.	DESCRIPTION
		<b>FL tube</b>
Q7501	212229	HNA-16MM39T
		<b>Remote sensor</b>
U7501	241341	SPS-444-1-E1
		<b>IC</b>
Q7502	22241571R3	MPD780232GC-030-8BT

## PRINTED CIRCUIT BOARD-PARTS LIST 2

## CIRCUIT NO. PART NO. DESCRIPTION

CIRCUIT NO.	PART NO.	DESCRIPTION
	<b>Transistors</b>	
Q7504	2216230R2 or 2214540R2	KRA103S or RN2403
Q7506	2216190R2 or 2214470R2	KRC102S or RN1402
	<b>Diodes</b>	
D7501	224490820R2, 224550820R2 or 224660824R2	UDZ8.2B, UDZS8.2B or HZU8.2B
D7502	224490510R2, 224550510R2 or 224660514R2	UDZ5.1B, UDZS5.1B or HZU5.1B
D7503,D7507	223234R2 or 223269R2	1SS352 or 1SS355
D7505	225290	SEL4110R
	<b>Coils</b>	
L7504,L7505	231237K220R2	NCH-1477
	<b>Oscillator</b>	
X7501	3010242	CST5.00MGW
	<b>Capacitors</b>	
C7502	355783309	33uF,50V,Elect.
C7514	394621017	100uF,6.3V,Elect.
C7521	355722219	220uF,6.3V,Elect.
	<b>Switches</b>	
S7501	25065627	EC12E2425,Rotary
S7611~S7613	25035699 or	NPS-111-S662 or
S7621~S7627	25035714	NPS-111-S677
S7631~S7637	25035699 or	NPS-111-S662 or
S7641~S7647	25035714	NPS-111-S677
	<b>Sockets</b>	
JL7501A	25051107	NSCT-3P894
JL7502A	25051109	NSCT-5P896
P7502A	25051892 or 25052477	NSCT-10P1679 or NSCT-10P2374
P7503A	25052054 or 25051852	NSCT-8P1841 or NSCT-8P1639
	<b>Holder</b>	
Q7501A	27190989A	(FL)

## STANDBY SWITCH PC BOARD(NASW-7404-1A)

CIRCUIT NO.	PART NO.	DESCRIPTION
S7614~S7616	25035699 or 25035714	NPS-111-S662 or NPS-111-S677,Switch
JL7501B	25051107	NSCT-3P894,Socket

## HEADPHONE TERMINAL PC BOARD(NAETC-7405-1A)

CIRCUIT NO.	PART NO.	DESCRIPTION
P7501	25045514	YKB26-5005,Terminal
JL7502B	25051109	NSCT-5P896,Socket

## FRONT VIDEO PC BOARD (NAETC-7406-1A)

CIRCUIT NO.	PART NO.	DESCRIPTION
P251	25045680	NPJ-7PDB477,Terminal
P253B	2009990578UL	NSAS-10P0787,Socket
P261B	2009990513UL	NSAS-6P0675,Socket

## CONNECTOR PC BOARD (NAETC-7407-1A)

CIRCUIT NO.	PART NO.	DESCRIPTION
P801B	25051239	NSCT-14P1029,Socket
P206A	25055710	NPLG-14P666,Plug

## POWER AMPLIFIER DRIVER PC BOARD (NAAF-7409-2A)

CIRCUIT NO.	PART NO.	DESCRIPTION
	<b>Transistors</b>	
Q5000~Q5004	2215896,	* KTC3200-BL,
Q5010~Q5014	2210755, 2210756 or 2211733	* 2SC1775A-E, * 2SC1845-E
Q5030~Q5034	2215844, 2211353, 2211354 or 2215843	KTA1024-Y, 2SA949-O, 2SA949-Y or KTA1024-O
Q5040~Q5044	2215854, 2211633, 2211634 or 2215853	KTC3206-Y, 2SC2229-O, 2SC2229-Y or KTC3206-O
Q5050~Q5054	2215896, 2210755, 2210756, 2211732, 2211733 or 2215895	KTC3200-BL 2SC1775A-E, 2SC1775A-F, 2SC1845-F, 2SC1845-E or KTC3200-GR
	<b>Diodes</b>	
D5000~D5004	224470562	MTZJ5.6B
	<b>Capacitors</b>	
C5000~C5004	374721015	100pF+/-10%,50V,Plastic
C5010~C5014	393341017	100uF,16V,Elect.
C5020~C5024	394681007	10uF,50V,Elect.
C5040~C5044	393342217	220uF,16V,Elect.
C5050~C5054	394684707	47uF,50V,Elect.
C5100~C5104	394691007	10uF,100V,Elect.
C5110~C5114	394691007	10uF,100V,Elect.
	<b>Resistors</b>	
R5160~R5164	415471214	120ohm+/-5%,1/4W,NF carbon
R5170~R5174	415471214	120ohm+/-5%,1/4W,NF carbon
R5180~R5184	415471004	10ohm+/-5%,1/4W,NF carbon
R5190~R5194	415471004	10ohm+/-5%,1/4W,NF carbon
	<b>Sockets</b>	
P6000A~P6004A	25052288	NSCT-5P2185
P6011A	25052292	NSCT-9P2189
	<b>Plug</b>	
P306A	25055154	NPLG-10P138

## REGULATOR PC BOARD (NAETC-7410-2A)

CIRCUIT NO.	PART NO.	DESCRIPTION
	<b>IC</b>	
Q6931	222780565JRC	NJM78M56FA
	<b>Diodes</b>	
D6932,D6933	22380260 or 22380035	RL1N4003 or GP104003E
	<b>Capacitors</b>	
C6931	394651027	1000uF,25V,Elect.
C6933	394641007	10uF,16V,Elect.
	<b>Resistor</b>	
R6935	441721214	120ohm+/-5%,2W,Metal oxide
	<b>Sockets</b>	
JL9501A	25051111	NSCT-7P898
P410A,P411A	25051235	NSCT-10P1025
P6931A	25051240	NSCT-15P1030
P7503B	25052241, 25051312, 25051852 or 25052054	NSCT-8P2138, NSCT-8P1101, NSCT-8P1639 or NSCT-8P1841

CAUTION: Replacement for transistor of mark \*, if necessary must be made from the same beta group (hFE) as the original type.

## PRINTED CIRCUIT BOARD-PARTS LIST 3

NOTE: THE COMPONENTS IDENTIFIED BY MARK  ARE CRITICAL FOR RISK OF FIRE AND ELECTRIC SHOCK. REPLACE ONLY WITH PART NUMBER SPECIFIED.

## SECONDARY PC BOARD (NAETC-7411-2A)

CIRCUIT NO.	PART NO.	DESCRIPTION
	<b>Resistors</b>	
R9501	453530104	1ohm+/-5%,1/2W,Metal
R9502	453534794	0.47ohm+/-5%,1/2W,Metal
R9503	453532294	0.22ohm+/-5%,1/2W,Metal
R9521	453530224	2.2ohm+/-5%,1/2W,Metal
	<b>Socket</b>	
JL9501B	25051111	NSCT-7P898





## SPEAKER TERMINAL PC BOARD (NAETC-7412-2A)

CIRCUIT NO.	PART NO.	DESCRIPTION
	<b>Diodes</b>	
D6600,D6601	223163,	1SS133,
D6604	223205 or 223222	1SS270A or WG713A
	<b>Capacitor</b>	
C6600	374721034	0.01uF+/-5%,50V,Plastic
	<b>Terminals</b>	
P6800	25060315	NTM-4PDMN246
P6801	25060317	NTM-4PDML248
P6802	25060318	NTM-6PDMN249
	<b>Relays</b>	
RL6600,RL6601	25065563,	NRL-2P5A-DC24-129,
RL6603,RL6604	25065517 or 25065586	NRL-2P5A-DC24-098 or NRL-2P5A-DC24-142
	<b>Sockets</b>	
JL6803B	25050269	NSCT-5P97
JL6804B	25050269	NSCT-5P97
JL6805B	25050268	NSCT-4P96

## POWER AMPLIFIER PC BOARD (NAAF-7417-2A)

CIRCUIT NO.	PART NO.	DESCRIPTION
	<b>Transistors</b>	
Q6010-Q6014	2213284 or	* 2SC1740S-R or
Q6020-Q6024	2213285	* 2SC1740S-S
Q6030-Q6034	2203434 or 2203010	KTD2061-Y or 2SC5171
Q6040-Q6044	2203424 or 2203000	KTB1369-Y or 2SA1930
Q6050-Q6054	2203563, 2202842, 2202843, 2203562, 2203663, 2203664 or 2203666	* KTC5242-O, * 2SC5242-R, * 2SC5242-O, * KTC5242-R, * MN130S-O, * MN130S-Y or * MN130S-P
Q6060-Q6066	2203553, 2202832, 2202833, 2203552, 2203673, 2203674 or 2203676	* KTA1962-O, * 2SA1962-R, * 2SA1962-O, * KTA1962-R, * MP130S-O, * MP130S-Y or * MP130S-P
Q6070-Q6074	2214984 or 2214985	2SC2631-R or 2SC2631-S
Q6303	2215995, 2213354 or 2213355	KTA1267-GR, 2SA933S-R or 2SA933S-S
Q6701,Q6702	2215896, 2210755, 2210756, 2211732, 2211733 or 2215895	KTC3200-BL, 2SC1775A-E, 2SC1775A-F, 2SC1845-F, 2SC1845-E or KTC3200-GR

CAUTION: Replacement for transistor of mark \*, if necessary must be made from the same beta group (h<sub>FE</sub>) as the original type.

CIRCUIT NO.	PART NO.	DESCRIPTION
	<b>Transistors</b>	
Q6703	2215885, 2215886, 2211792 or 2211793	KTA1268-GR, KTA1268-BL, 2SA992-F or 2SA992-E
Q6601-Q6603	2215864,	KTC3199-GR,
Q6901	2212115, 2213284 or 2213285	2SC2458-GR, 2SC1740S-R or 2SC1740S-S
	<b>Diodes</b>	
D6000-D6004	223163,	1SS133,
D6306,D6307	223205 or	1SS270A or
D6701,D6702	223222	WG713A
D6703,D6704	224470512	MTZJ5.1B
D6903,D6904	22380130, 22380038 or 22380274	D5SBA20, RBV602 or RS603M
D6906	223163, 223205 or 223222	1SS133, 1SS270A or WG713A
	<b>Capacitors</b>	
C6040-C6044	394684707	47uF,50V,Elect.
C6230-C6234	374724734	0.047uF+/-5%,50V,Plastic
C6701,C6706	394621017	100uF,6.3V,Elect.
C6704	394680107	1uF,50V,Elect.
C6901,C6902	3504384	10000uF,71V,Elect.
C6903	374721044	0.1uF+/-5%,50V,Plastic
C6904C6905	374723344	0.33uF+/-5%,50V,Plastic
C6906,C6907	374721044	0.1uF+/-5%,50V,Plastic
	<b>Resistors</b>	
R6040-R6044	5210258	N06HR1KBC,Trimming
R6070-R6074	415471114	110ohm+/-5%,1/4W,NF carbon
R6080-R6084	415470224	2.2ohm+/-5%,1/4W,NF carbon
R6090-R6094	415470224	2.2ohm+/-5%,1/4W,NF carbon
R6100-R6104	4800071, 4000131 or 4500027,	RSS2WK-0.22, RGC22-0.22 OHMK or MPC708-2WK-0.22, Metal plate
R6230-R6234	453630824	8.2ohm+/-5%,1W,Metal
R6850,R6851	443523914	390ohm+/-5%,1/2W,Metal oxide
	<b>Fuses</b>	
F6901,	252198 or	 8A-UL or
F6902	252261	 8A-T/UL-ST2,Fuse
	<b>Fuse holders</b>	
F6901A,F6901B	25052133	 NSCT-1P2031
F6902A,F6902B	25052133	 NSCT-1P2031
	<b>Relays</b>	
RL6901	25065561,	NRL-1P5A-DC12-127,
RL6902	25065508, 25065515 or 25065526	NRL-1P10A-DC12-093, NRL-1P5A-DC12-096 or NRL-1P5A-DC12-102
	<b>Sockets</b>	
JL6402A	25051087	NSCT-3P874
JL6803A	25051109	NSCT-5P896
JL6804A	25051109	NSCT-5P896
JL6805A	25051108	NSCT-4P895
JL6951A	25051109	NSCT-5P896
JL6952A	25051109	NSCT-5P896
	<b>Plugs</b>	
P6000-P6004	25056010	NPLG-5P0960
P6011	25056014	NPLG-9P0964
P6080-P6084	25055038	NPLG-2P29
P6301	25055038	NPLG-2P29
P6931	25055711	NPLG-15P667
P931	25055701	NPLG-5P657
	<b>Radiator</b>	
D6903A	27160499	RAD-164

**PRINTED CIRCUIT BOARD-PARTS LIST 4**

**PRIMARY CIRCUIT PC BOARD (NAPS-7420-2A)**

CIRCUIT NO.	PART NO.	DESCRIPTION
<b>Transistors</b>		
Q921	2215864, 2212115, 2213284 or 2213285	KTC3199-GR, 2SC2458-GR, 2SC1740S-R or 2SC1740S-S
<b>Diodes</b>		
D921~D924	22380260 or 22380035	RL1N4003 or GP104003E
D925	223163, 223205 or 223222	1SS133, 1SS270A or WG713A
<b>Power transformer</b>		
T902	2301381	⚠ NPT-1358D
<b>Capacitors</b>		
C901	3500196	⚠ RE275V-103M,IS
C922	394662217	220uF,35V,Elect.
<b>Resistors</b>		
R901	4000206 or 431533355	⚠ RD1/2SPH-3.3M or ⚠ RC1/2GFKUL-3.3M,Solid
R924	443528204T	82ohm+/-5%,1/2W,Metal oxide
<b>Fuse</b>		
F901	252198 or 252261	⚠ 8A-UL or ⚠ 8A-T/UL-ST2,Fuse
<b>Fuse holders</b>		
F901A,F901B	25052133	⚠ NSCT-1P2031
<b>AC outlet</b>		
P902	25051571	⚠ NSCT-2P1358
<b>Relay</b>		
RL901	25065561, 25065508, 25065515 or 25065526	⚠ NRL-1P5A-DC12-127, ⚠ NRL-1P10A-DC12-093, ⚠ NRL-1P5A-DC12-096 or ⚠ NRL-1P5A-DC12-102
<b>Socket</b>		
P931A	25051230	NSCT-5P1020
<b>Plug</b>		
P901A	25055675 or 25056028	⚠ NPLG-2P631 or ⚠ NPLG-2P0978
<b>Label</b>		
F901C	29360842	Fuse

**TERMINAL PC BOARD (NAETC-7421-2A)**

CIRCUIT NO.	PART NO.	DESCRIPTION
JL6951B	25051109	NSCT-5P896,Terminal
JL6952B	25051109	NSCT-5P896,Terminal

**VIDEO TERMINAL PC BOARD (NAVD-7422-2A)**

CIRCUIT NO.	PART NO.	DESCRIPTION
<b>ICs</b>		
Q203	22241759	LA7956
Q212,Q213	22241759	LA7956
Q281	222740046R2	74HCU04F
<b>Transistors</b>		
Q201,Q202	2213631 or	RN1241-A or
Q207,Q208	2213632	RN1241-B
Q204,Q209	2215995 or 2213354	KTA1267-GR or 2SA933S-R
Q205,Q206	2215770 or 2213510	KRA102M or DTA114ES
Q210,Q211	2213631 or 2213632	RN1241-A or RN1241-B
<b>Photo couplers</b>		
U281,U282	24120083, 24120086 or 24120095	GP1FA550RZ, GP1FA551RZ or TORX179

CIRCUIT NO.	PART NO.	DESCRIPTION
<b>Coils</b>		
L281,L282	233454K220	NCH-1452 220K
L283	233454M022	NCH-1452 022M
<b>Capacitors</b>		
C201,C202	394680227	2.2uF,50V,Elect.
C203,C205	394641017	100uF,16V,Elect.
C204,C207	394680227	2.2uF,50V,Elect.
C209,C213	394680227	2.2uF,50V,Elect.
C211,C215	394641017	100uF,16V,Elect.
C217,C218	394680227	2.2uF,50V,Elect.
C221,C223	394644707	47uF,16V,Elect.
C225	394644707	47uF,16V,Elect.
C285,C288	394624707	47uF,6.3V,Elect.
<b>Terminals</b>		
P201,P202	25045681	NPJ-10PDBY478
P203	25045682	NPJ-5PDBY479
P281	25045473	NPJ-1PDBL291
P282	25045504	NPJ-1PDBL319
<b>Socket</b>		
P206B	25051239	NSCT-14P1029
<b>Plug</b>		
P253A	25055236	NPLG-5P220

**THERMAL DETECTOR PC BOARD (NAETC-7424-2A)**

CIRCUIT NO.	PART NO.	DESCRIPTION
<b>Thermistor</b>		
R6380	4000152	PTH9M04BE222TSF333
<b>Socket</b>		
JL6402B	25051087	NSCT-3P874

**NOTE: THE COMPONENTS IDENTIFIED BY MARK ⚠ ARE CRITICAL FOR RISK OF FIRE AND ELECTRIC SHOCK. REPLACE ONLY WITH PART NUMBER SPECIFIED.**



A B C D E

# MAIN MICROPROCESSOR-CONNECTION DIAGRAM

1  
2  
3  
4

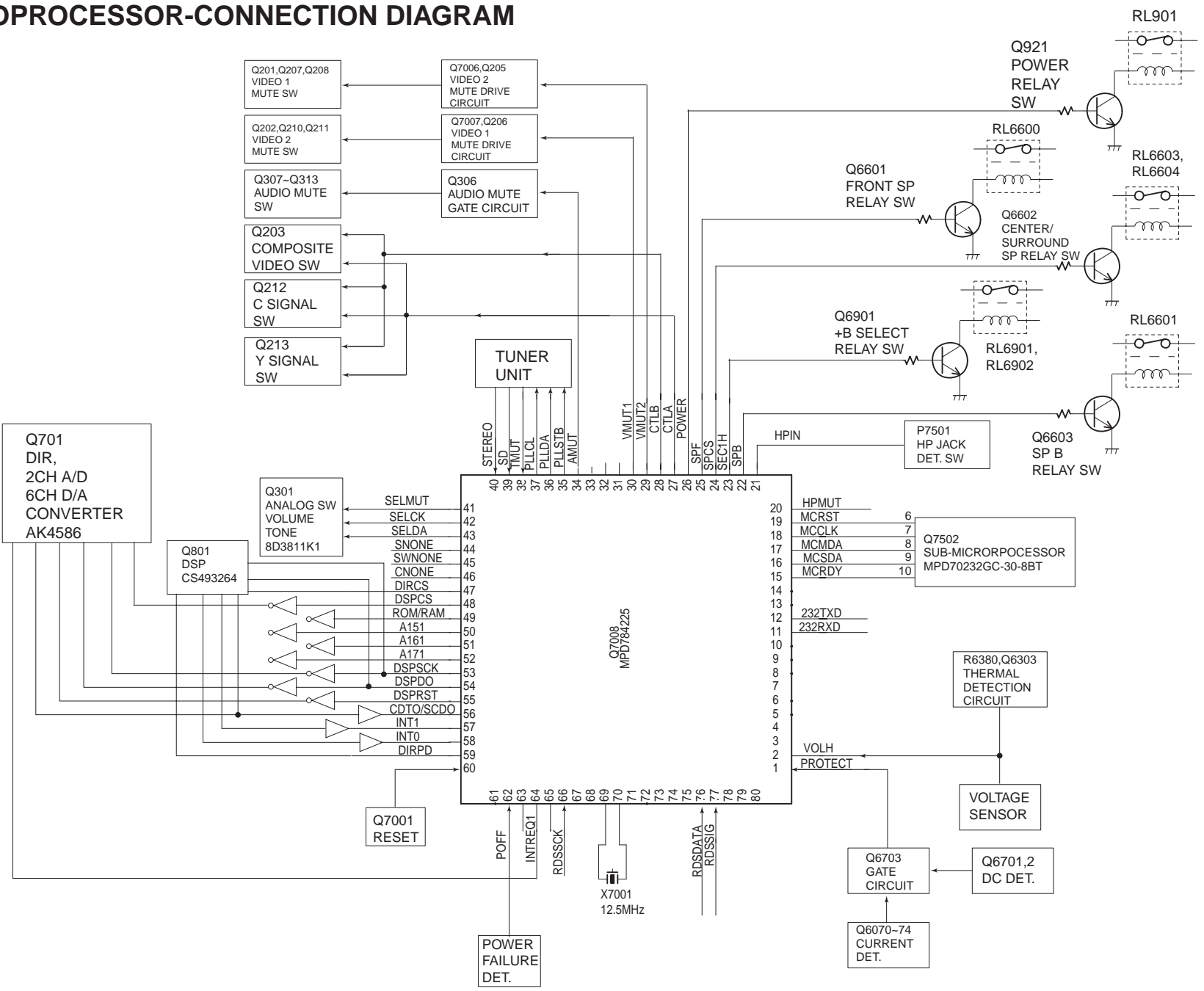

# SUB-MICROPROCESSOR CONNECTION DIAGRAM

1

2

3

4

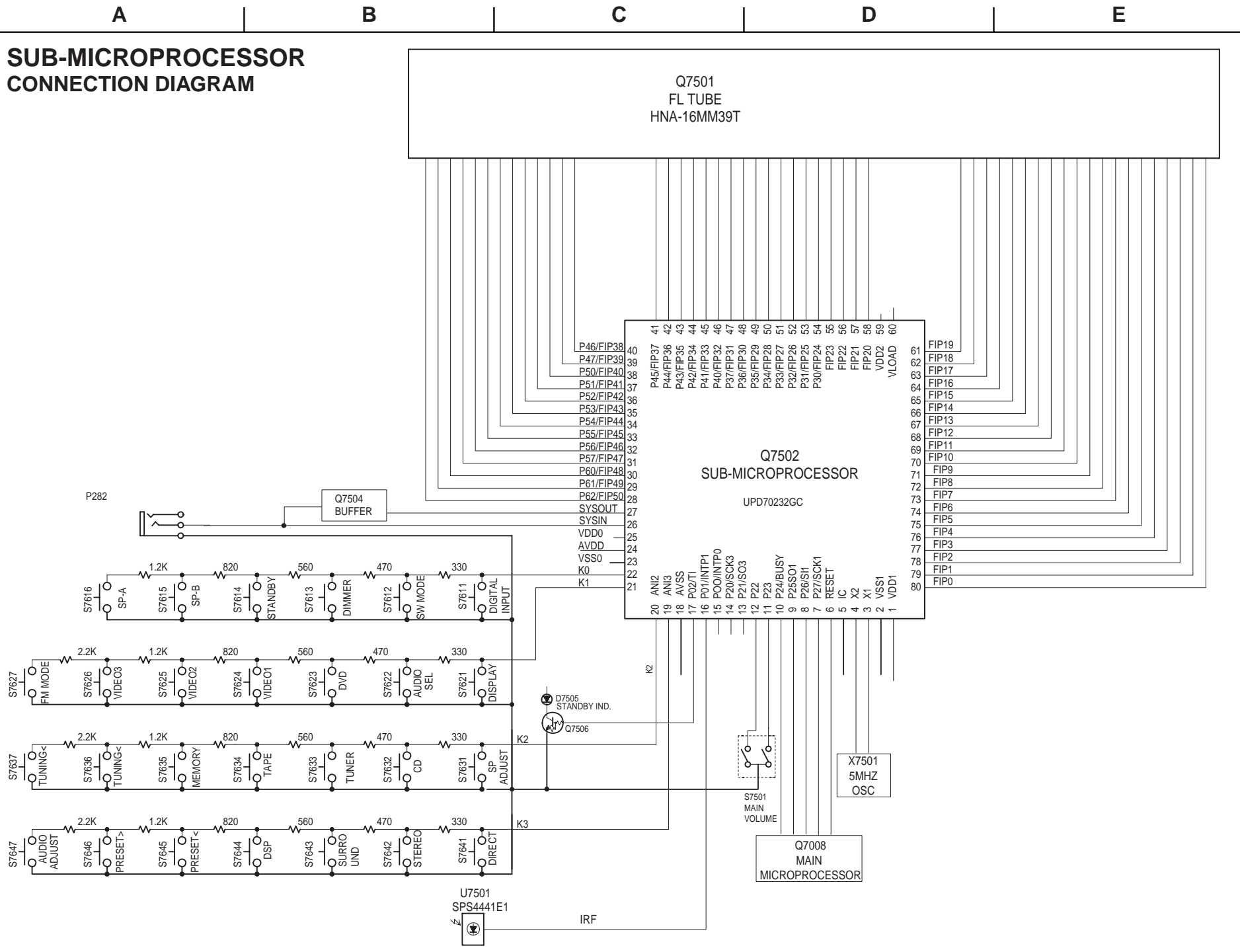

## TERMINAL DESCRIPTION

### MAIN MICROPROCESSOR

No.	Terminal	I/O	Description
1	PROTECT	I	Protection circuit detection input terminal
2	VOLH	I	Power amplifier voltage detection terminal.
3	BAND	I	Region setting input terminal.
11	232TXD		Not used.
12	232RXD		Not used.
15	MCRDY	I	Data ready detection input terminal from the sub microprocessor.
16	MCSDa	I	Data input terminal from the sub microprocessor.
17	MCMDA	O	Data output terminal to the sub microprocessor.
18	MCCLK	O	Serial clock output terminal to the sub microprocessor
19	~MCRST	O	Reset signal output terminal to the sub microprocessor
20	HPMUT	O	Muting control output terminal for headphone amplifier.
21	HPIN	I	Input terminal to detect the connection of headphone
22	SPBRL	O	Speaker B relay control output terminal.
23	SEC1H	O	Voltage +/-B control output terminal.
24	SPAC SRL	O	Speaker relay control output terminal for center and surround channels
25	SPAFRL	O	Speaker relay A control output terminal for front channels
26	POWERRL	O	Power source relay control output terminal
27	VCTRLA	O	Control signal A output terminal for the video selector switch
28	VCTRLB	O	Control signal B output terminal for the video selector switch
29	VMUT2	O	Muting control output terminal for the video section 2
30	VMUT1	O	Muting control output terminal for the video section 1
34	AMUT	O	Audio muting control output terminal
35	PLLSTB	O	Strobe signal output terminal to PLL IC
36	PLLSDO	O	Serial data output terminal to PLL IC
37	PLLCLK	O	Serial clock output terminal to PLL IC
38	TUMUT	O	Muting control output terminal for the tuner section
39	~SD	I	Broadcast detection input terminal more than a muting level.
40	~STEREO	I	FM stereo broadcast detection input terminal
41	SELMUT	O	Muting control output terminal for selector, volume and tone IC BD3811.
42	SELCLK	O	Serial clock output terminal of IC BD3811.
43	SELSDO	O	Serial data and latch signal output terminal for IC BD3811
44	SNONE	O	Not used.
45	SWNONE	O	Not used.
46	CNONE	O	Not used.
47	~DIRCS	O	Chip select signal output terminal to DIR IC AK4586
48	~DSPCS	O	Chip select signal output terminal to DSP IC.
49	~ROM/RAM	O	ROM/RAM select terminal. Not used.
50	ADDR151	O	DSP boot ROM address 15 select terminal. Not used.
51	ADDR161	O	DSP boot ROM address 16 select terminal. Not used.
52	ADDR171	O	DSP boot ROM address 17 select terminal. Not used.
53	DSPCLK	O	Serial clock output terminal for DIR and DSP ICs.
54	DSPSDO	O	Serial data output terminal for DIR and DSP ICs.
55	~DSPRST	O	Reset signal output terminal to DSP IC.
56	CDTO/SCDO	I	Serial data input terminal from DIR and DSP ICs.
57	INT1	I	Input terminal to detect the status of DIR IC.
58	INT0	I	Input terminal to detect the unlock of DIR IC.
59	~DIRPD	O	Power down terminal to DIR and CODEC ICs.
60	RESET	I	Reset input terminal
62	POFF	I	Power failure detection input terminal
64	~INTREQ/~ABOOT	I/O	Interrupter input terminal from DSP IC.
66	~RD SCLK	I	RDS clock input terminal. Not used.
69	X2		Connect the ceramic oscillator 12.5MHz.
70	X1		Connect the ceramic oscillator 12.5MHz.
71	TEST/VPP		Test terminal.
72	XT2		Not used.
73	XT1		Not used.
76	RDS DATA	I	Data input terminal of RDS broadcast. Not used.
77	RDSSIG	I	Input terminal to check the signal of RDS broadcast. Not used.

## TERMINAL DESCRIPTION

### SUB MICROPROCESSOR

Pin No.	Symbol	I/O	Description	Pin No.	Symbol	I/O	Description
1	VDD		Power supply terminal. Connect to 5V.	41	P22	O	Segment output terminal of P22.
2	VSS		Ground terminal.	42	P21	O	Segment output terminal of P21.
3	X1		Ceramic oscillator connection terminals for main system.	43	P20	O	Segment output terminal of P20.
4	X2		Connect the 5MHz ceramic oscillator between #3 and #4.	44	P19	O	Segment output terminal of P19.
5	IC/VPP		Internal connection terminal	45	P18	O	Segment output terminal of P18.
6	~RESET	I	System reset signal input terminal.	46	P17	O	Segment output terminal of P17.
7	SUBCL/SCK	I	Clock input terminal to transmit the signal from main microprocessor.	47	P16	O	Segment output terminal of P16.
8	SUBDO/SDI	I	Data input terminal to transmit the signal from main microprocessor.	48	P15	O	Segment output terminal of P15.
9	SUBDI/SDD	O	Data output terminal to transmit the signal to main microprocessor.	49	P14	O	Segment output terminal of P14.
10	SUBLDY	O	Data ready output terminal to transmit to the main microprocessor.	50	P13	O	Segment output terminal of P13.
11	VBJ	I	Pulse input terminal from the rotary encoder of volume.	51	P12	O	Segment output terminal of P12.
12	VAJ	I	Pulse input terminal from the rotary encoder of volume.	52	P11	O	Segment output terminal of P11.
13	SSCBJ	I	Not used.	53	P10	O	Segment output terminal of P10.
14	SSCAJ	I	Not used.	54	P9	O	Segment output terminal of P9.
15	~IRIN	I	Not used.	55	P8	O	Segment output terminal of P8.
16	~IRF	I	Signal input terminal from the remote controller.	56	P7	O	Segment output terminal of P7.
17	STBYLED	O	Standby LED control output terminal.	57	P6	O	Segment output terminal of P6.
18	AVSS		Ground terminal for A/D converter.	58	P5	O	Segment output terminal of P5.
19	K3	I	Operation key connection terminal.	59	VDD2		Power supply terminal. Apply +5V.
20	K2	I	Operation key connection terminal.	60	VLOAD		Negative power supply terminal of FL controller.
21	K1	I	Operation key connection terminal.	61	P4	O	Segment output terminal of P4.
22	K0	I	Operation key connection terminal.	62	P3	O	Segment output terminal of P3.
23	VSS0		Ground terminal	63	P2	O	Segment output terminal of P2.
24	AVDD		Power supply terminal for A/D converter.	64	P1	O	Segment output terminal of P1.
25	VDDD		Power supply terminal. Apply +5V.	65	16G	O	Grid output terminal of 16G.
26	~SYSIN	I	System code input terminal.	66	15G	O	Grid output terminal of 15G.
27	~SYSOUT	O	System code output terminal.	67	14G	O	Grid output terminal of 14G.
28	P35	O	Segment output terminal of P35.	68	13G	O	Grid output terminal of 13G.
29	P34	O	Segment output terminal of P34.	69	12G	O	Grid output terminal of 12G.
30	P33	O	Segment output terminal of P33.	70	11G	O	Grid output terminal of 11G.
31	P32	O	Segment output terminal of P32.	71	10G	O	Grid output terminal of 10G.
32	P31	O	Segment output terminal of P31.	72	9G	O	Grid output terminal of 9G.
33	P30	O	Segment output terminal of P30.	73	8G	O	Grid output terminal of 8G.
34	P29	O	Segment output terminal of P29.	74	7G	O	Grid output terminal of 7G.
35	P28	O	Segment output terminal of P28.	75	6G	O	Grid output terminal of 6G.
36	P27	O	Segment output terminal of P27.	76	5G	O	Grid output terminal of 5G.
37	P26	O	Segment output terminal of P26.	77	4G	O	Grid output terminal of 4G.
38	P25	O	Segment output terminal of P25.	78	3G	O	Grid output terminal of 3G.
39	P24	O	Segment output terminal of P24.	79	2G	O	Grid output terminal of 2G.
40	P23	O	Segment output terminal of P23.	80	1G	O	Grid output terminal of 1G.

# ADJUSTMENT AND CONFIRMATION PROCEDURES 1

## Idling current adjustment

Before Idling adjustment, turn the trimming resistors R6040, R6041, R6042, R6043 and R6044 to counter clockwise. Connect the DC voltmeter to sockets P6080, P6081, P6082, P6083 and P6084.

After turn POWER to ON, adjust the trimming resistors R6040 and R6041 so that the reading of voltmeter becomes 2.5 mV. (Front channels)

Adjust the trimming resistors R6042, R6043 and R6044 so that the reading of voltmeter becomes 1.5 mV. (Center and surround channels)

After adjustment, attach the top cover.

Confirm the voltage of points above after about five minutes.

### Front and center channels

When less than 7.0 mV, readjust the resistors above so that the voltage becomes 7.0 mV.

When 7.0 mV to 9.0 mV, you are not necessary to adjust.

When more than 9.0 mV, readjust the resistors above so that the voltage becomes 9.0 mV.

### Surround channels

When less than 4.0 mV, readjust the resistors above so that the voltage becomes 4.0 mV.

When 4.0 mV to 6.0 mV, you are not necessary to adjust.

When more than 6.0 mV, readjust the resistors above so that the voltage becomes 6.0 mV.

Note: No load and No signal

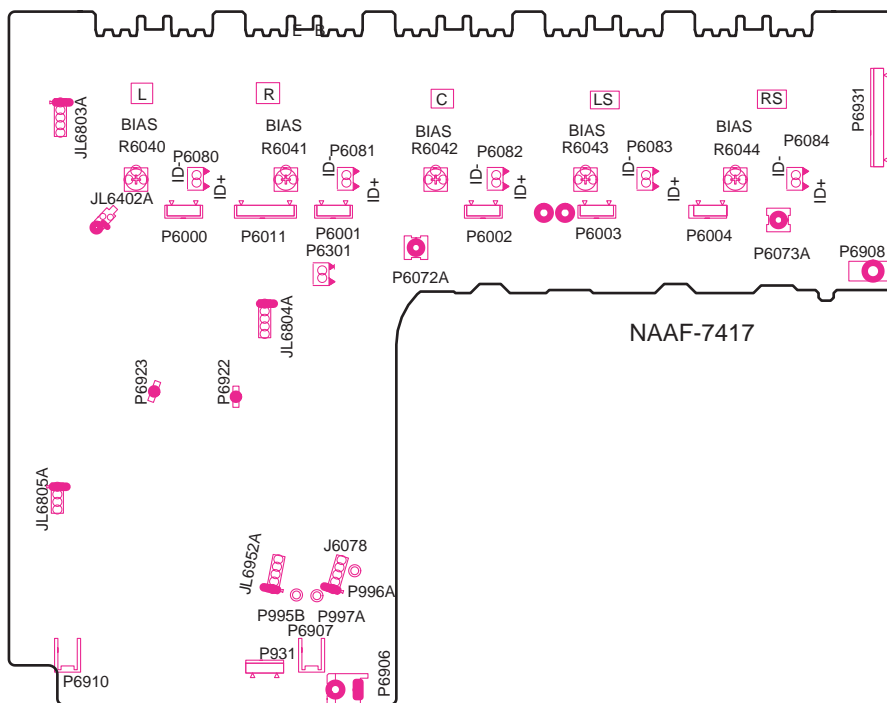

## Confirmation of protection circuit

### 1. Confirmation of operation of speaker relay

Confirm that the speaker relays turn ON approximate. 5 seconds after the power switch is turned ON.

Confirm that the speaker relays turn OFF immediately after the power switch is turned OFF.

### 2. Confirmation of DC detection circuit

Press and hold down CD button, then press STANDBY/ON and DISPLAY buttons to set the unit to "TEST-1" mode.

After "TEST-1" on the FL tube light on, press VIDEO 1 button to set the unit to "TEST-1-00".

Apply DC 1.5 to 3V to DVD INPUT terminal with no load.

Confirm that the speaker relay turns OFF.

Apply DC -1.5 to -3V to DVD INPUT terminal with no load.

Confirm that the speaker relay turns OFF.

Caution: Don't apply DC voltage more than 1 sec..

## ADJUSTMENT AND CONFIRMATION PROCEDURES 2

### 3. Confirmation of Current detection circuit

Set the unit to "TEST-1-00".

Connect the differentiating circuit and apply the 200Hz square signal to MULTI CHANNEL INPUT terminal of each channel.

Adjust the attenuator or Volume so that the output level becomes 35V p-p.

Confirm that "Protect" indicator does not turn OFF when a 3.0 ohm load is connected.

Confirm that "Protect" indicator lights on when a 1.5 ohm load is connected.

Caution: Don't continue more than 3 seconds.

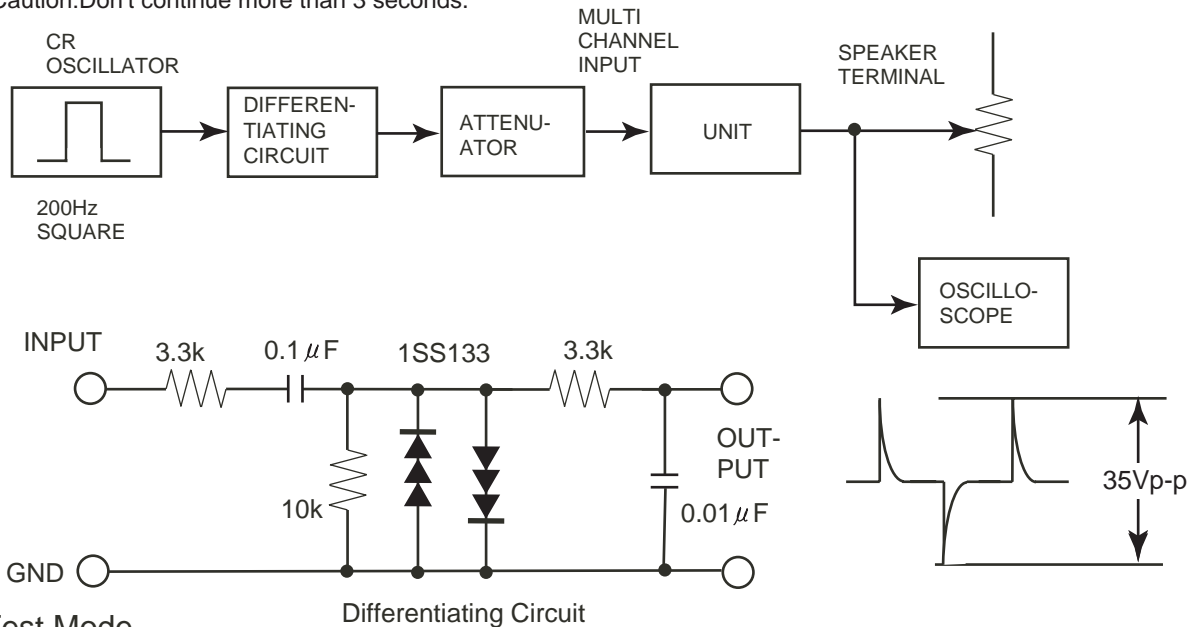

#### Test Mode

1. Turn POWER button on.
2. Press and hold down CD button, then press STANDBY/ON button.
3. After "TEST-" on the FL tube is displayed, press CD button to set the unit to the test mode of FL tube.

Note: DVD:TEST-1 VIDEO 1 :TEST-2 SP-A: UP  
VIDEO 2 :TEST-3 VIDEO 3:TEST-4 SP-B: DOWN

#### Test mode of FL tube

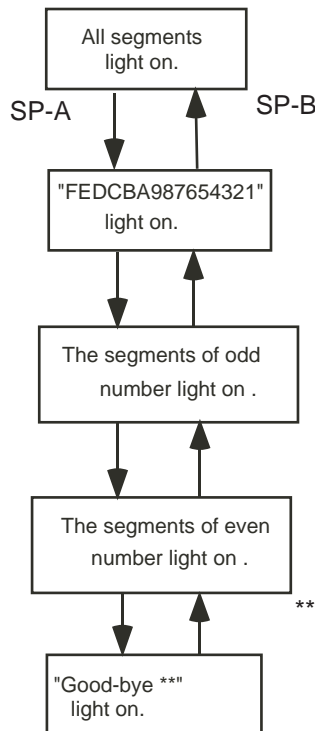

\*\* : Region US:U.S.A.  
EU:Europe  
WR:Other models

Press POWER button to finish the test mode of FL tube.

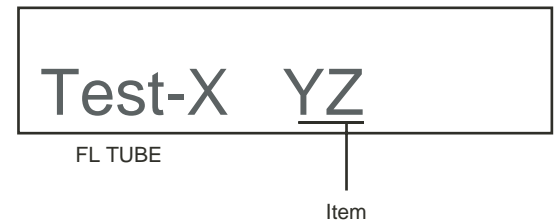

#### Confirmation of voltage sensor

1. Set the unit to TEST-3-2.
2. Apply the signal 1kHz, -15dBV to the MULTI-CH input. Confirm that the FM STEREO is displayed. Confirm the all channels except SUBWOFFER.
3. When connect the resistor 2.7 kohm/1 W between the terminals COM and TH1 of P6301, confirm that "FM STEREO" light on.  
Note: No input signal.
4. When set the unit to "TEST-4-30, confirm that the speaker relays of RL6901 and RL6902 turn off.  
Note: No input signal.

PACKING PROCEDURES

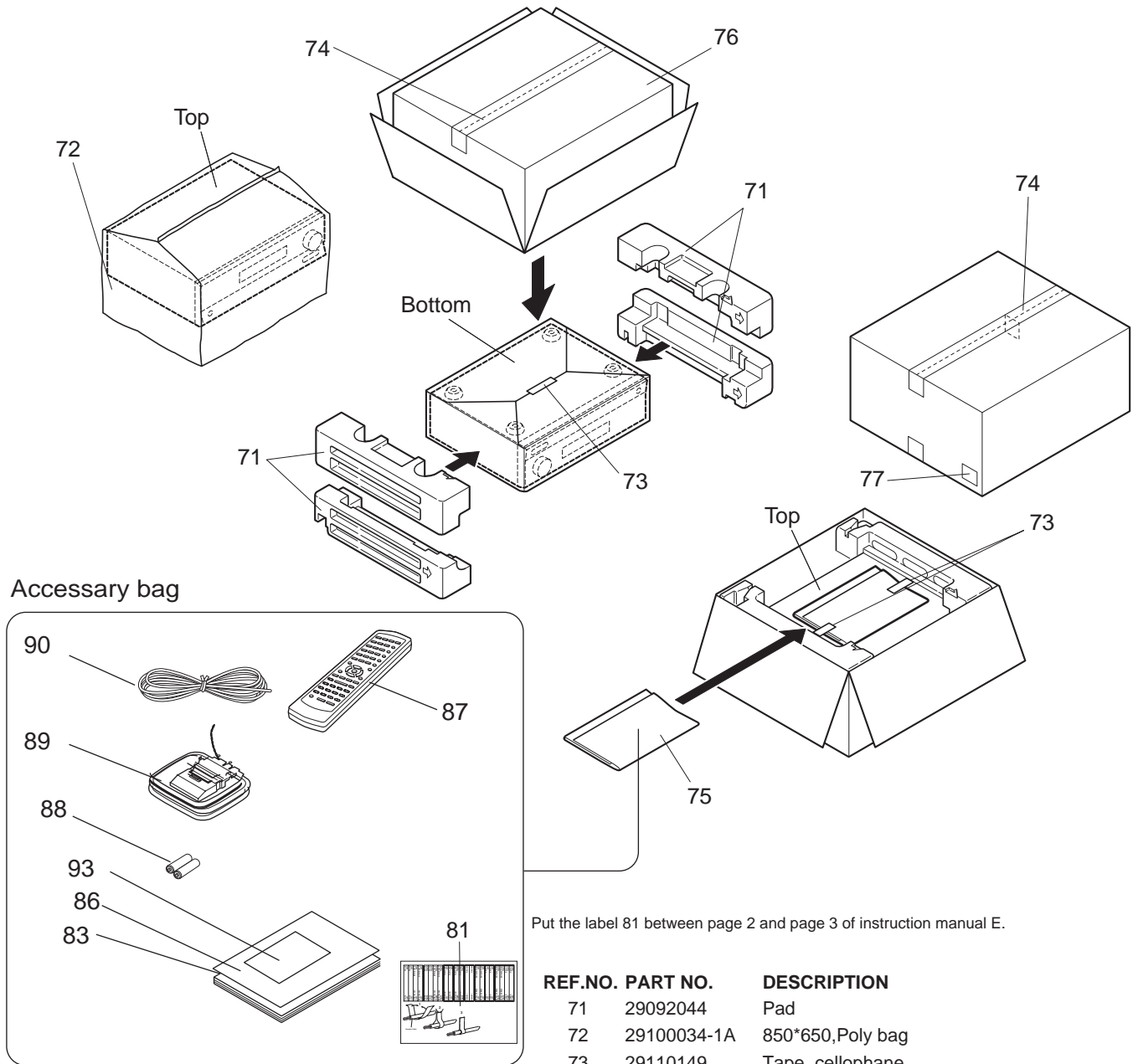

Put the label 81 between page 2 and page 3 of instruction manual E.

REF.NO.	PART NO.	DESCRIPTION
71	29092044	Pad
72	29100034-1A	850*650,Poly bag
73	29110149	Tape, cellophane
74	29110148	PP tape
75	29100201	350*200*W250,Polybag
76	29053904B	Carton box
77	29363120	Label UPC
81	29363059A	Label,cable
83	29343336A	Instruction manual E
86	29343337	Instruction manual,digest
87	24140478	RC-478M,Remote controller (Before change)
	24140518	RC-518M,Remote controller (After change)
	29355407	Instruction sheet for RC-518M
88	3010054	UM-3,Two batteries
89	232140	NMA-3057,AM loop antenna
90	292142	FM antenna
93	29365090A	Warranty card

---

**ONKYO CORPORATION**

Sales & Product Planning Div. : 2-1, Nisshin-cho, Neyagawa-shi, OSAKA 572-8540, JAPAN  
Tel: 072-831-8111 Fax: 072-833-5222

**ONKYO U.S.A. CORPORATION**

18 Park Way, Upper Saddle River, N.J. 07458, U.S.A.  
Tel: 201-785-2600 Fax: 201-785-2650 E-mail: onkyo@onkyousa.com

**ONKYO EUROPE ELECTRONICS GmbH**

Liegnitzerstrasse 6, 82194 Grobenzell, GERMANY  
Tel: +49-8142-4401-0 Fax: +49-8142-4401-555 E-mail: info@onkyo.de

**ONKYO CHINA LIMITED**

Units 2102-2107, Metroplaza Tower I, 223 Hing Fong Road, Kwai Chung,  
N.T., HONG KONG Tel: 852-2429-3118 Fax: 852-2428-9039