

ONKYO SERVICE MANUAL

7.1-CH HOME THEATER RECEIVER MODEL HT-R960

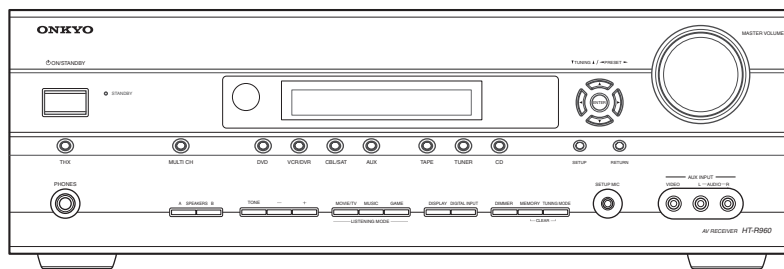

RC-708M

Black model

B MDC	120V AC, 60Hz
B MPP	230V AC, 50Hz

SAFETY-RELATED COMPONENT WARNING!!

COMPONENTS IDENTIFIED BY MARK  ON THE SCHEMATIC DIAGRAM AND IN THE PARTS LIST ARE CRITICAL FOR RISK OF FIRE AND ELECTRIC SHOCK. REPLACE THESE COMPONENTS WITH ONKYO PARTS WHOSE PART NUMBERS APPEAR AS SHOWN IN THIS MANUAL.

MAKE LEAKAGE-CURRENT OR RESISTANCE MEASUREMENTS TO DETERMINE THAT EXPOSED PARTS ARE ACCEPTABLY INSULATED FROM THE SUPPLY CIRCUIT BEFORE RETURNING THE APPLIANCE TO THE CUSTOMER.

EXPLODED VIEWS-1

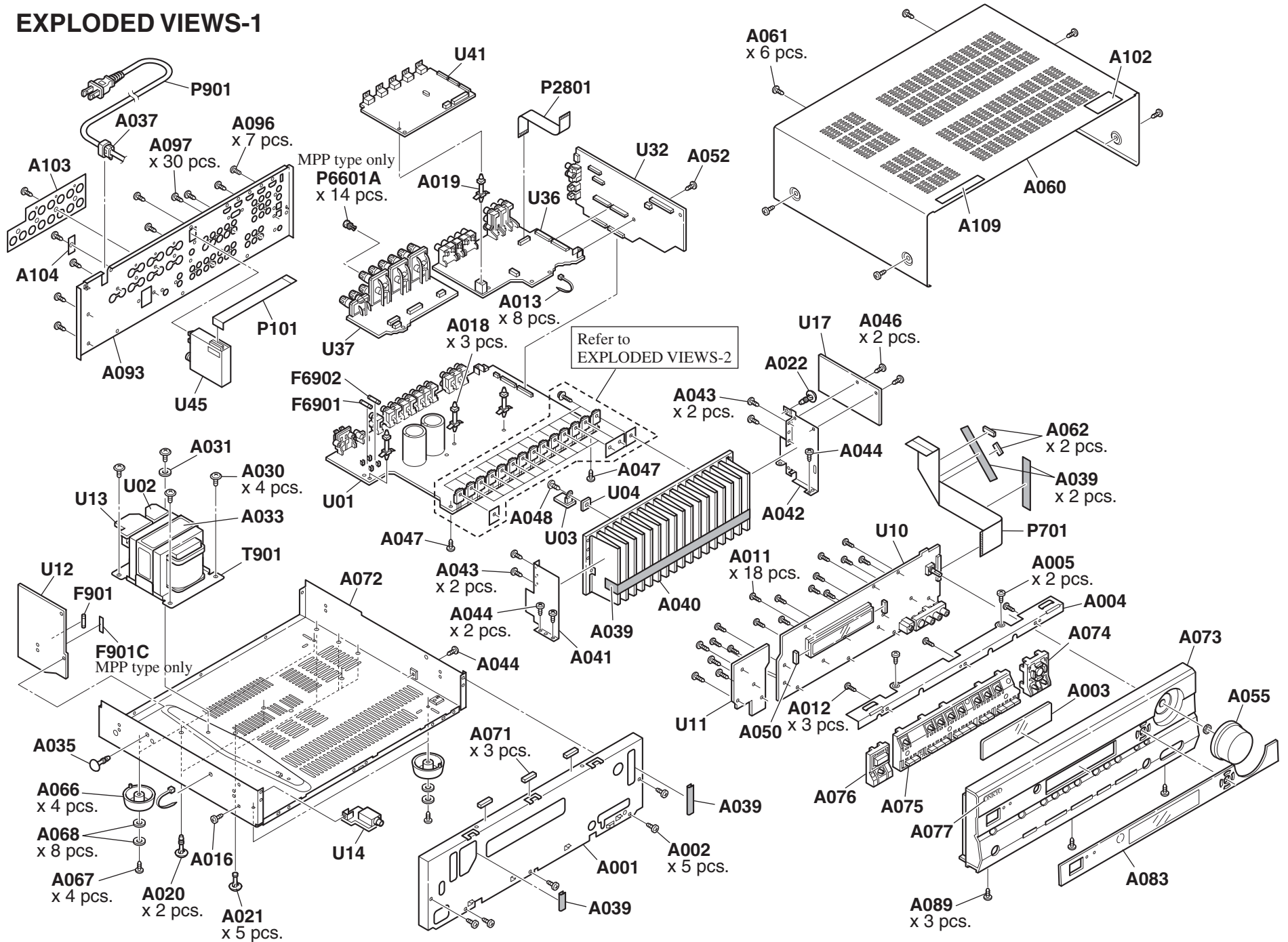

EXPLODED VIEWS-2

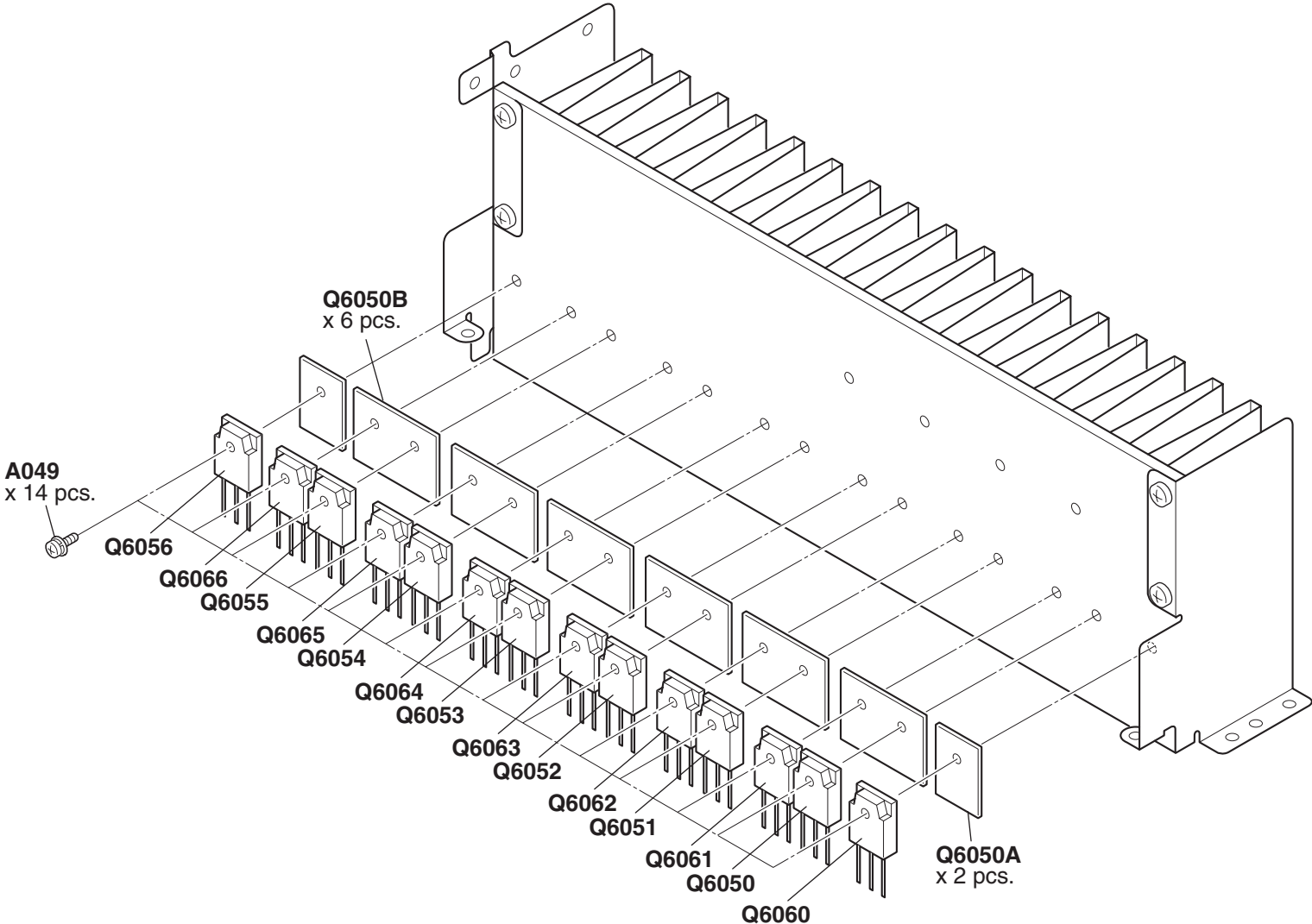

BLOCK DIAGRAMS-1 AUDIO SECTION

1
2
3
4
5

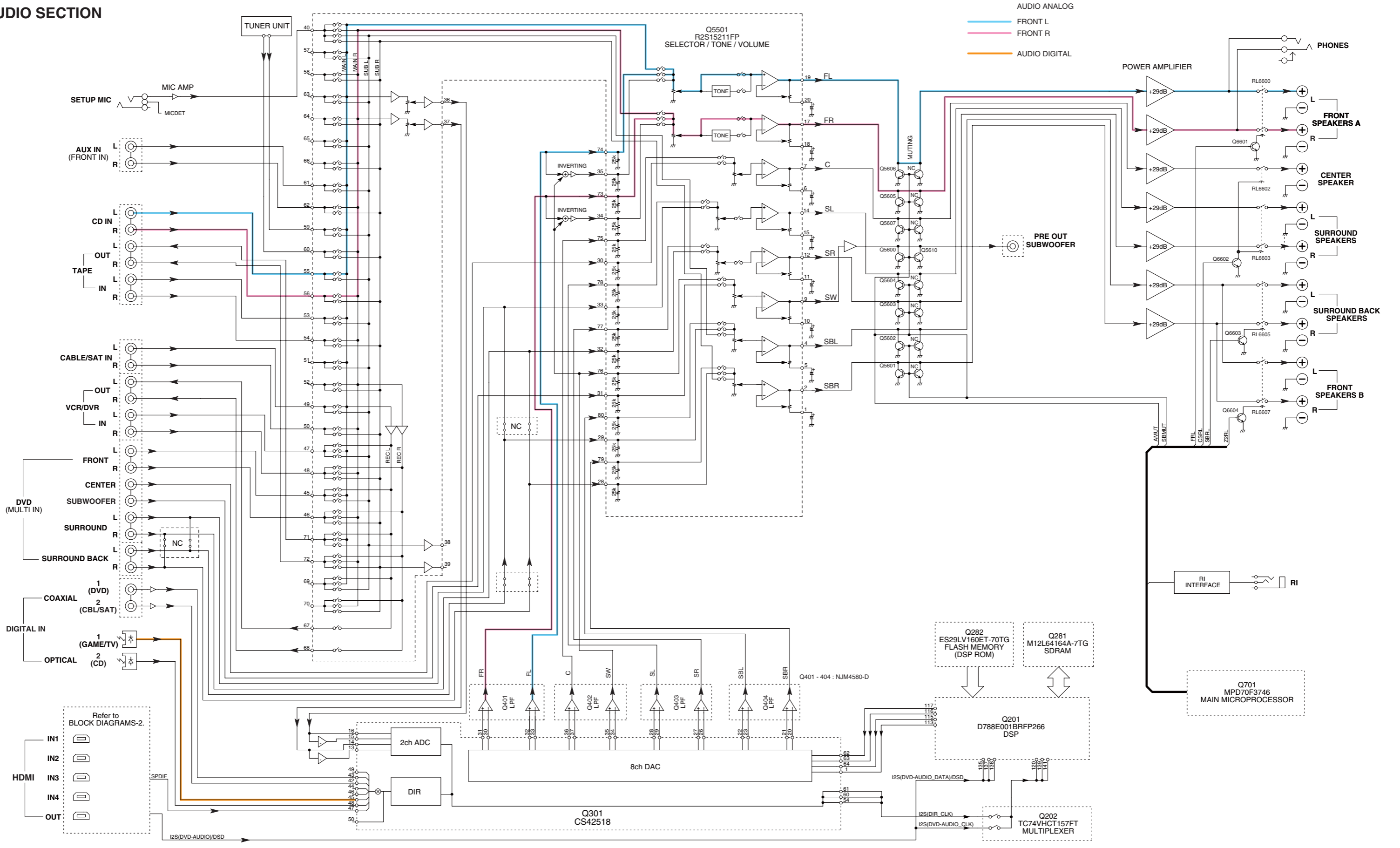

BLOCK DIAGRAM HDMI SECTION

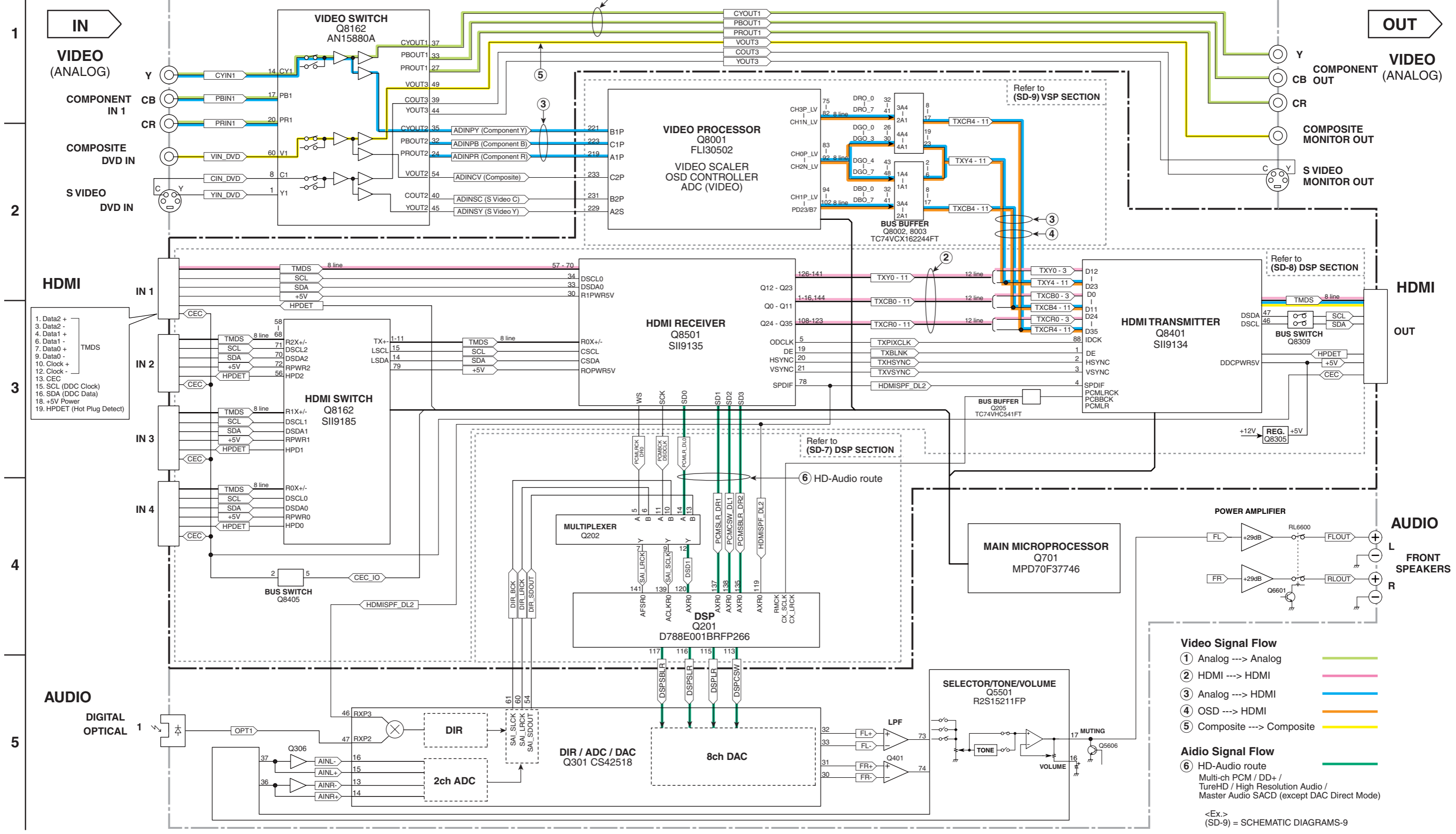

- 1 VIDEO (ANALOG)
- 2 COMPONENT IN 1
- 3 COMPOSITE DVD IN
- 4 S VIDEO DVD IN

- 5 Y COMPONENT OUT
- 6 CB CR
- 7 COMPOSITE MONITOR OUT
- 8 S VIDEO MONITOR OUT

- 9 HDMI IN 1
- 10 HDMI IN 2
- 11 HDMI IN 3
- 12 HDMI IN 4

- 13 HDMI OUT

- 14 AUDIO DIGITAL OPTICAL

- 15 AUDIO FRONT SPEAKERS

1. Data2 +
2. Data2 -
3. Data1 +
4. Data1 -
5. Data0 +
6. Data0 -
7. Clock +
8. Clock -
9. CEC
10. SCL (DDC Clock)
11. SDA (DDC Data)
12. +5V Power
13. HPDET (Hot Plug Detect)

Video Signal Flow

- ① Analog ----> Analog
- ② HDMI ----> HDMI
- ③ Analog ----> HDMI
- ④ OSD ----> HDMI
- ⑤ Composite ----> Composite

Audio Signal Flow

- ⑥ HD-Audio route

Multi-ch PCM / DD+ /
TrueHD / High Resolution Audio /
Master Audio SACD (except DAC Direct Mode)

<Ex.>
(SD-9) = SCHEMATIC DIAGRAMS-9

SCHEMATIC DIAGRAMS-1 (SD-1) AUDIO INPUT SECTION

1

2

3

4

5

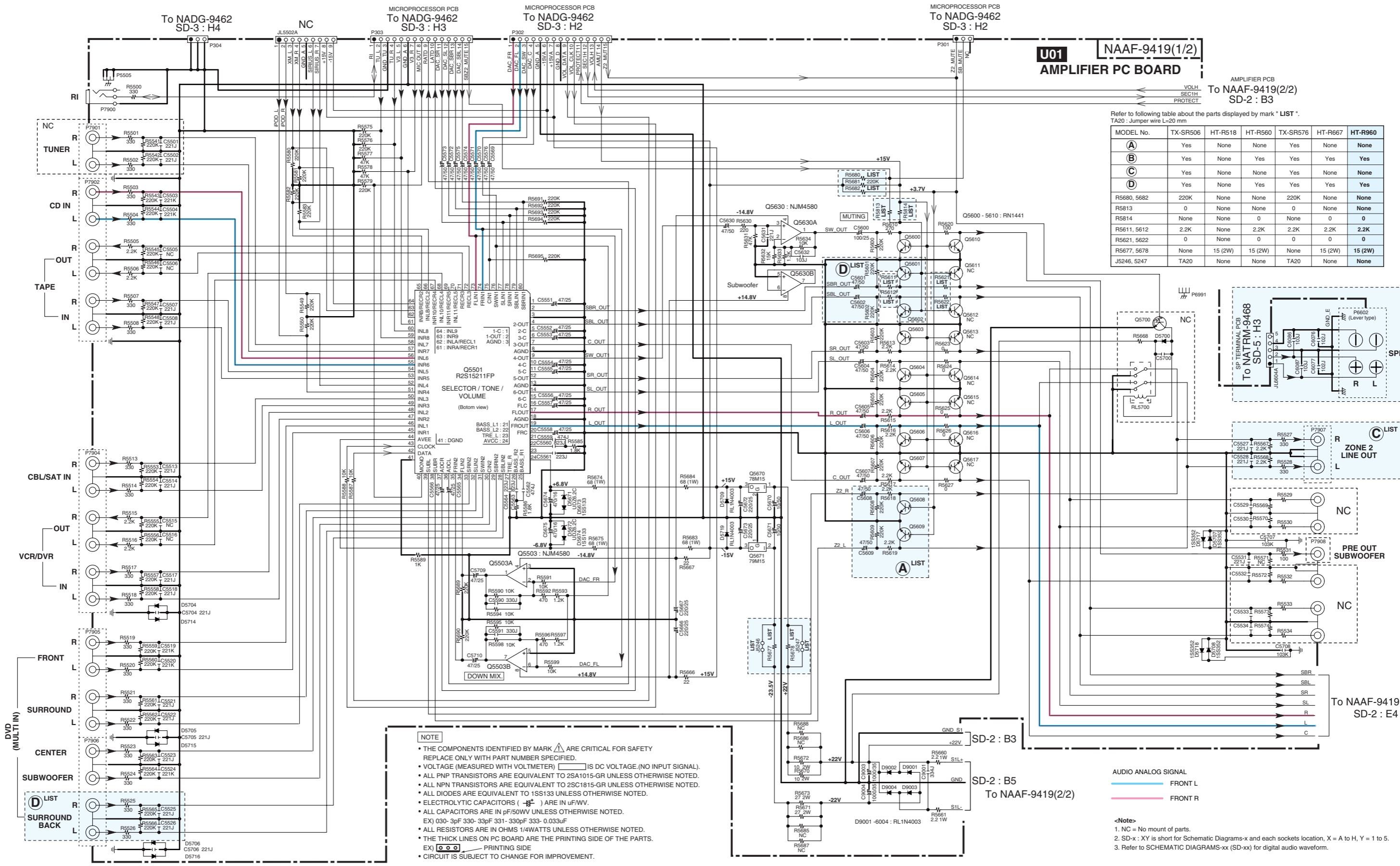

U01 NAAF-9419(1/2)
AMPLIFIER PCB

AMPLIFIER PCB
To NAAF-9419(2/2)
SD-2 : B3

Refer to following table about the parts displayed by mark "LIST".
TA20 : Jumper wire L=20 mm

MODEL No.	TX-SR506	HT-R518	HT-R560	TX-SR576	HT-R667	HT-R960
(A)	Yes	None	None	Yes	None	None
(B)	Yes	None	Yes	Yes	Yes	Yes
(C)	Yes	None	None	Yes	None	None
(D)	Yes	None	Yes	Yes	Yes	Yes
R5680, 5682	220K	None	None	220K	None	None
R5813	0	None	None	0	None	None
R5814	None	None	0	None	0	0
R5611, 5612	2.2K	None	2.2K	2.2K	2.2K	2.2K
R5621, 5622	0	None	0	0	0	0
R5677, 5678	None	15 (2W)	15 (2W)	None	15 (2W)	15 (2W)
J5246, 5247	TA20	None	None	TA20	None	None

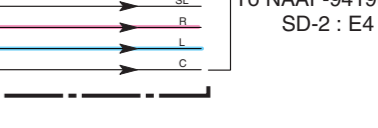
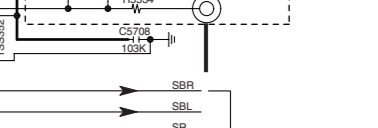
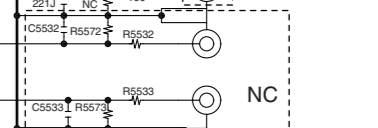
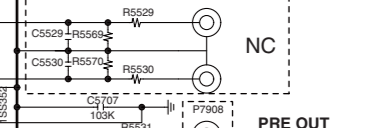
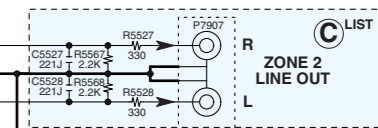
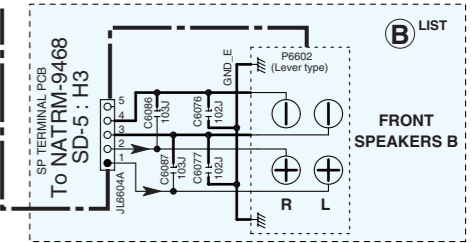

NOTE

- THE COMPONENTS IDENTIFIED BY MARK Δ ARE CRITICAL FOR SAFETY. REPLACE ONLY WITH PART NUMBER SPECIFIED.
- VOLTAGE (MEASURED WITH VOLTMETER) \square IS DC VOLTAGE (NO INPUT SIGNAL).
- ALL PNP TRANSISTORS ARE EQUIVALENT TO 2SA1015-GR UNLESS OTHERWISE NOTED.
- ALL NPN TRANSISTORS ARE EQUIVALENT TO 2SC1815-GR UNLESS OTHERWISE NOTED.
- ALL DIODES ARE EQUIVALENT TO 1SS133 UNLESS OTHERWISE NOTED.
- ELECTROLYTIC CAPACITORS (\square) ARE IN μ F/VV.
- ALL CAPACITORS ARE IN pF/50VW UNLESS OTHERWISE NOTED.
EX) 030-3pF 330-33pF 331-330pF 333-0.033uF
- ALL RESISTORS ARE IN OHMS 1/4WATTS UNLESS OTHERWISE NOTED.
- THE THICK LINES ON PC BOARD ARE THE PRINTING SIDE OF THE PARTS.
EX) \square PRINTING SIDE
- CIRCUIT IS SUBJECT TO CHANGE FOR IMPROVEMENT.

AUDIO ANALOG SIGNAL

FRONT L
FRONT R

<Note>

1. NC = No mount of parts.
2. SD-x : XY is short for Schematic Diagrams-x and each sockets location, X = A to H, Y = 1 to 5.
3. Refer to SCHEMATIC DIAGRAMS-xx (SD-xx) for digital audio waveform.

SCHEMATIC DIAGRAMS-2 (SD-2) POWER AMPLIFIER SECTION

U01 AMPLIFIER PC BOARD NAAF-9419 (2/2)

<Note>
 1. NC = No mount of parts.
 2. SD-x : XY is short for Schematic Diagrams-x and each sockets location, X = A to H, Y = 1 to 5.

Refer to following table about the parts displayed by mark "LIST".

MODEL No.→	TX-SR506		HT-R518		HT-R560		TX-SR576		HT-R667		HT-R960	
TYPE→	MDD, MDC	MPP, MPB	MGG, MGO, MGR, MWF	MWT, MWO, MWF	MPP	MDD, MDC	MPP	MDD, MDC, MPA	MPP	MDD	MDC	MPP
A		Yes			None	Yes		Yes		Yes		Yes
Q6050 - 6052	MN130S	2SC5198	MN130S	2SC5242	2SC5242	2SC5242	MN130S	2SC5198	2SC5242	2SC5242	2SC5242	2SC5242
Q6060 - 6062	MP130S	2SA1941	MP130S	2SA1962	2SA1962	2SA1962	MP130S	2SA1941	2SA1962	2SA1962	2SA1962	2SA1962
Q6053 - 6054	MN130S	2SC5198	MN130S	2SC5242	2SC5242	2SC5242	MN130S	2SC5198	2SC5242	2SC5242	2SC5242	2SC5242
Q6063 - 6064	MP130S	2SA1941	MP130S	2SA1962	2SA1962	2SA1962	MP130S	2SA1941	2SA1962	2SA1962	2SA1962	2SA1962
Q6055 - 6056	2SC5198	2SC5198	2SC5198	2SC5198	2SC5198	2SC5198	2SC5198	2SC5198	2SC5198	2SC5198	2SC5198	2SC5198
Q6065 - 6066	2SA1941	2SA1941	2SA1941	2SA1941	2SA1941	2SA1941	2SA1941	2SA1941	2SA1941	2SA1941	2SA1941	2SA1941
C6901, 6902		8200/63		10000/69	10000/63	10000/63		10000/63		10000/63		10000/69
Q5050 - 56		2SC1815		2SC2240	2SC2240	2SC2240		2SC1815		2SC1815		2SC2240
R5160 - 5166		100(1/4W)		150(1/4W)	100(1/4W)	100(1/4W)		100(1/4W)		100(1/4W)		150(1/4W)
R5170 - 5176		100(1/4W)		150(1/4W)	100(1/4W)	100(1/4W)		100(1/4W)		100(1/4W)		150(1/4W)
R6070 - 6072		82(1/4W)		120(1/4W)	120(1/4W)	120(1/4W)		82(1/4W)		82(1/4W)		120(1/4W)
R6073 - 6076		100(1/4W)		120(1/4W)	120(1/4W)	120(1/4W)		100(1/4W)		100(1/4W)		120(1/4W)
R6710		5.6K		5.6K	4.7K	4.7K		5.6K		5.6K		4.7K

AUDIO ANALOG SIGNAL
 FRONT L
 FRONT R

AMPLIFIER PCB SD-1 : F5
 To NAAF-9419(1/2)
 SD-1 : G1

TRANS. SEC. TERMINAL PCB
 To NAPS-9420
 SD-5 : D3

AMPLIFIER PCB
 To NAAF-9419(1/2)
 SD-1 : F5

SPEAKER TERMINAL PCB
 To NATRM-9468
 SD-5 : H2

SPEAKER TERMINAL PCB
 To NATRM-9468
 SD-5 : E3

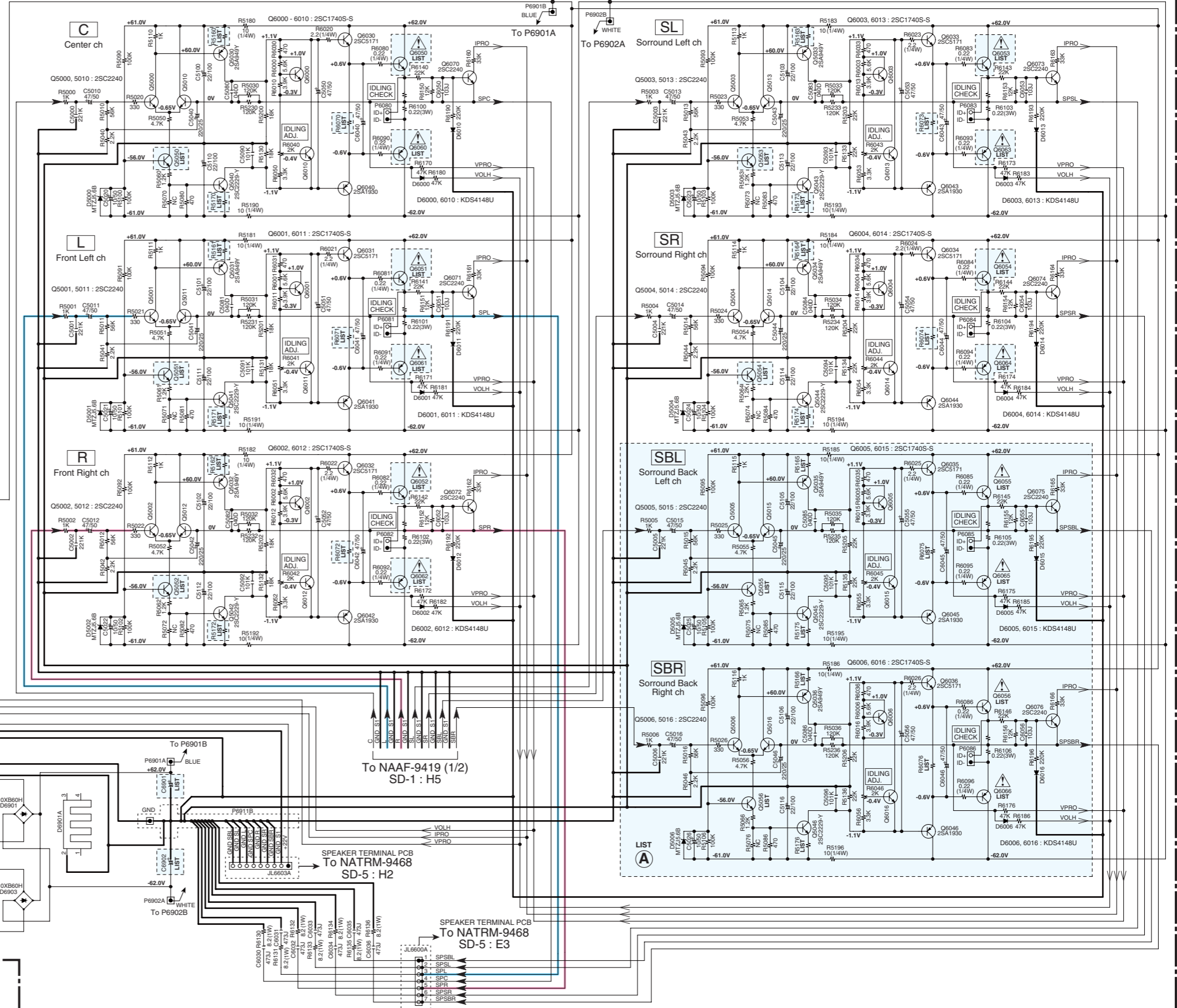

1

2

3

4

5

SCHEMATIC DIAGRAMS-3 (SD-3) MICROPROCESSOR SECTION

1
2
3
4
5

NADG-9462
U32
MICROPROCESSOR PC BOARD

DISPLAY PCB
To NADIS-9430
SD-6 : H1

VIDEO PCB
To NAVD-9467
SD-4 : G4

NAETC-9421
U03
THERMAL SENSOR PC BOARD

AMPLIFIER PCB
To NAAF-9419(1/2)
SD-1 : F1

AMPLIFIER PCB
To NAAF-9419(1/2)
SD-1 : D1

To NAAF-9419(1/2)
SD-1 : C1

To NAAF-9419(1/2)
SD-1 : B1

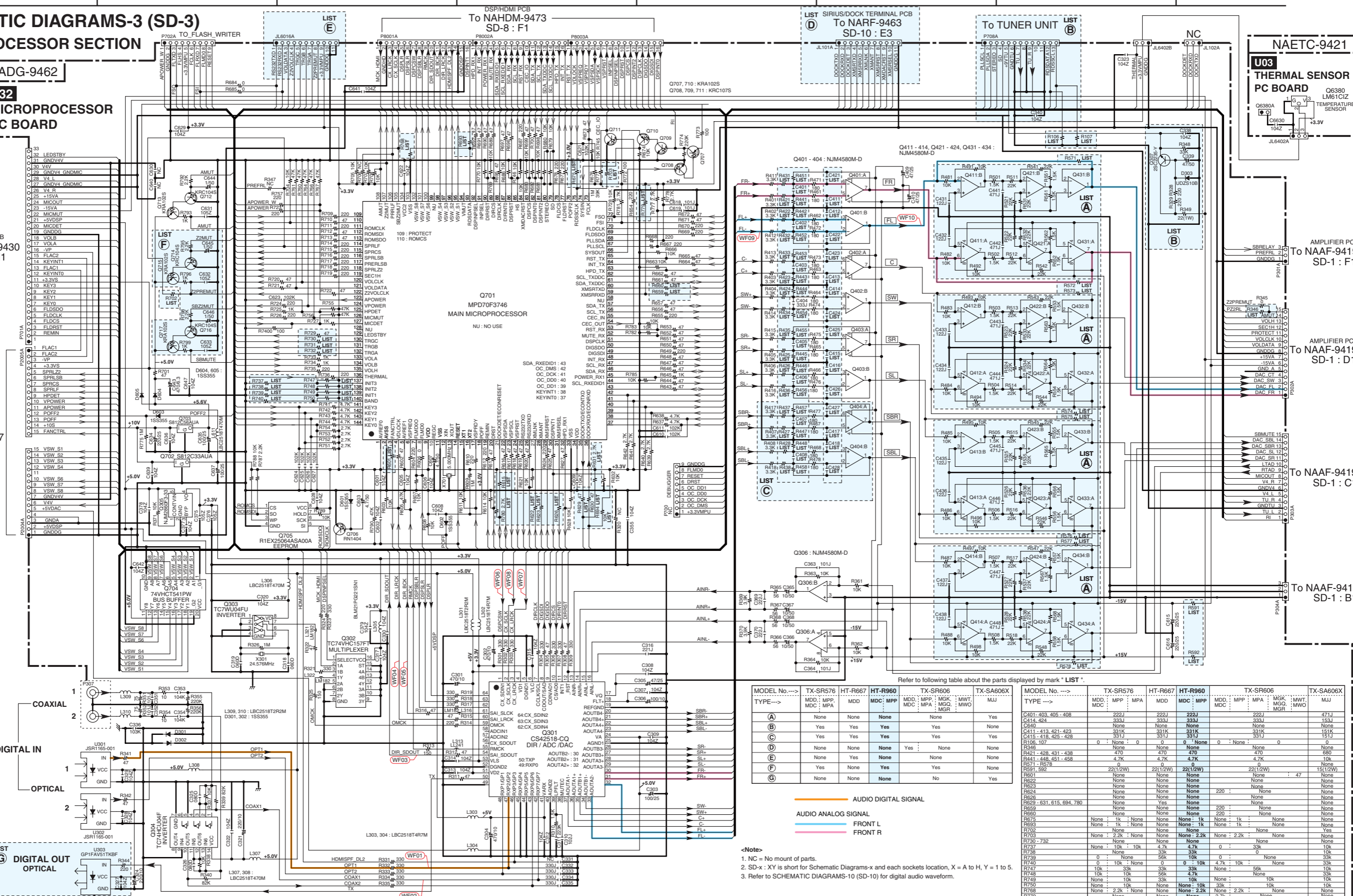

Refer to following table about the parts displayed by mark "LIST".

MODEL No. -->	TX-SR576	HT-R667	HT-R960	TX-SR606	TX-SA606X
TYPE -->	MDD ; MPP ; MPA	MDD	MDC ; MPP	MDD ; MPP ; MPA ; MGR	MJU
(A)	None	None	None	None	Yes
(B)	Yes	Yes	Yes	None	None
(C)	Yes	Yes	Yes	Yes	Yes
(D)	None	None	None	Yes ;	None
(E)	None	Yes	None	None	None
(F)	Yes	None	Yes	Yes	None
(G)	None	None	None	No	Yes



<Note>
 1. NC = No mount of parts.
 2. SD-x : XY is short for Schematic Diagrams-x and each sockets location, X = A to H, Y = 1 to 5.
 3. Refer to SCHEMATIC DIAGRAMS-10 (SD-10) for digital audio waveform.

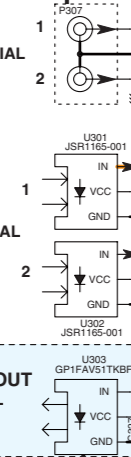

SCHEMATIC DIAGRAMS-4 (SD-4) VIDEO SECTION

1

2

3

4

5

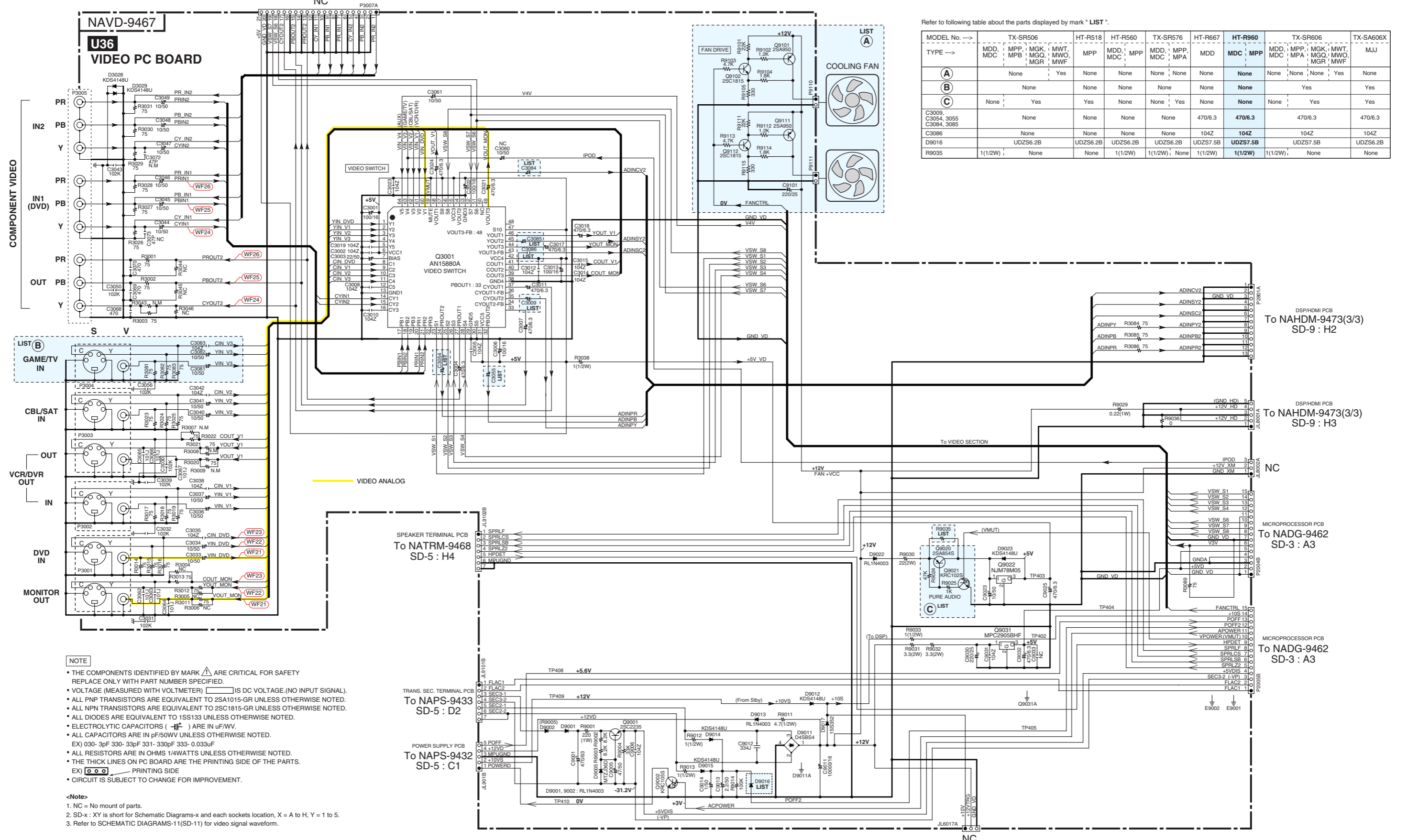

Refer to following table about the parts displayed by mark * LIST *.

MODEL No. -->	TX-SR506			HT-R518	HT-R560	TX-SR576	HT-R667	HT-R960	TX-SR606	TX-SA606X	
TYPE -->	MDD, MDC	MPP, MPB	MGK, MGR	MPP	MDD, MDC	MPP, MPA	MDD	MDC, MPP	MDD, MDC	MPP, MGK, MGR	MJJ
(A)	None	None	Yes	None	None	None	None	None	None	None	None
(B)	None	None	None	None	None	None	None	None	Yes	None	Yes
(C)	None	Yes	None	Yes	None	Yes	None	None	Yes	None	Yes
C3009, C3054, 3055, C3084, 3085	None	None	None	None	None	None	470/6.3	470/6.3	470/6.3	470/6.3	470/6.3
C3086	None	None	None	None	None	None	104Z	104Z	104Z	104Z	104Z
D9016	None	UDZS6.2B	None	UDZS6.2B	UDZS6.2B	UDZS6.2B	UDZS7.5B	UDZS7.5B	UDZS7.5B	UDZS6.2B	UDZS6.2B
R9035	1(1/2W)	None	None	None	1(1/2W)	1(1/2W)	None	1(1/2W)	1(1/2W)	None	None

- NOTE**
- THE COMPONENTS IDENTIFIED BY MARK Δ ARE CRITICAL FOR SAFETY. REPLACE ONLY WITH PART NUMBER SPECIFIED.
 - VOLTAGE (MEASURED WITH VOLTMETER) \square IS DC VOLTAGE (NO INPUT SIGNAL).
 - ALL PNP TRANSISTORS ARE EQUIVALENT TO 2SA1015-GR UNLESS OTHERWISE NOTED.
 - ALL NPN TRANSISTORS ARE EQUIVALENT TO 2SC1815-GR UNLESS OTHERWISE NOTED.
 - ALL DIODES ARE EQUIVALENT TO 1SS133 UNLESS OTHERWISE NOTED.
 - ELECTROLYTIC CAPACITORS (---) ARE IN $\mu\text{F/WV}$.
 - ALL CAPACITORS ARE IN pF/50WV UNLESS OTHERWISE NOTED.
EX) 030-3pF 330-33pF 331-330pF 333-0.033 μF
 - ALL RESISTORS ARE IN OHMS 1/4WATTS UNLESS OTHERWISE NOTED.
 - THE THICK LINES ON PC BOARD ARE THE PRINTING SIDE OF THE PARTS.
EX) \square PRINTING SIDE
 - CIRCUIT IS SUBJECT TO CHANGE FOR IMPROVEMENT.

<Note>

1. NC = No mount of parts.
2. SD-x : XY is short for Schematic Diagrams-x and each sockets location, X = A to H, Y = 1 to 5.
3. Refer to SCHEMATIC DIAGRAMS-11(SD-11) for video signal waveform.

SPEAKER TERMINAL PCB
To NATRM-9468
SD-5 : H4

TRANS. SEC. TERMINAL PCB
To NAPS-9433
SD-5 : D2

POWER SUPPLY PCB
To NAPS-9432
SD-5 : C1

DSP/HDMI PCB
To NAHDM-9473(3/3)
SD-9 : H2

DSP/HDMI PCB
To NAHDM-9473(3/3)
SD-9 : H3

MICROPROCESSOR PCB
To NADG-9462
SD-3 : A3

MICROPROCESSOR PCB
To NADG-9462
SD-3 : A3

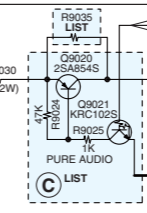
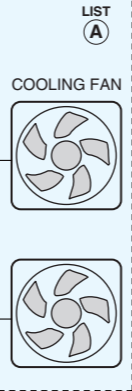

SCHEMATIC DIAGRAMS-5 (SD-5) SPEAKER TERMINAL / POWER SUPPLY SECTION

1

2

3

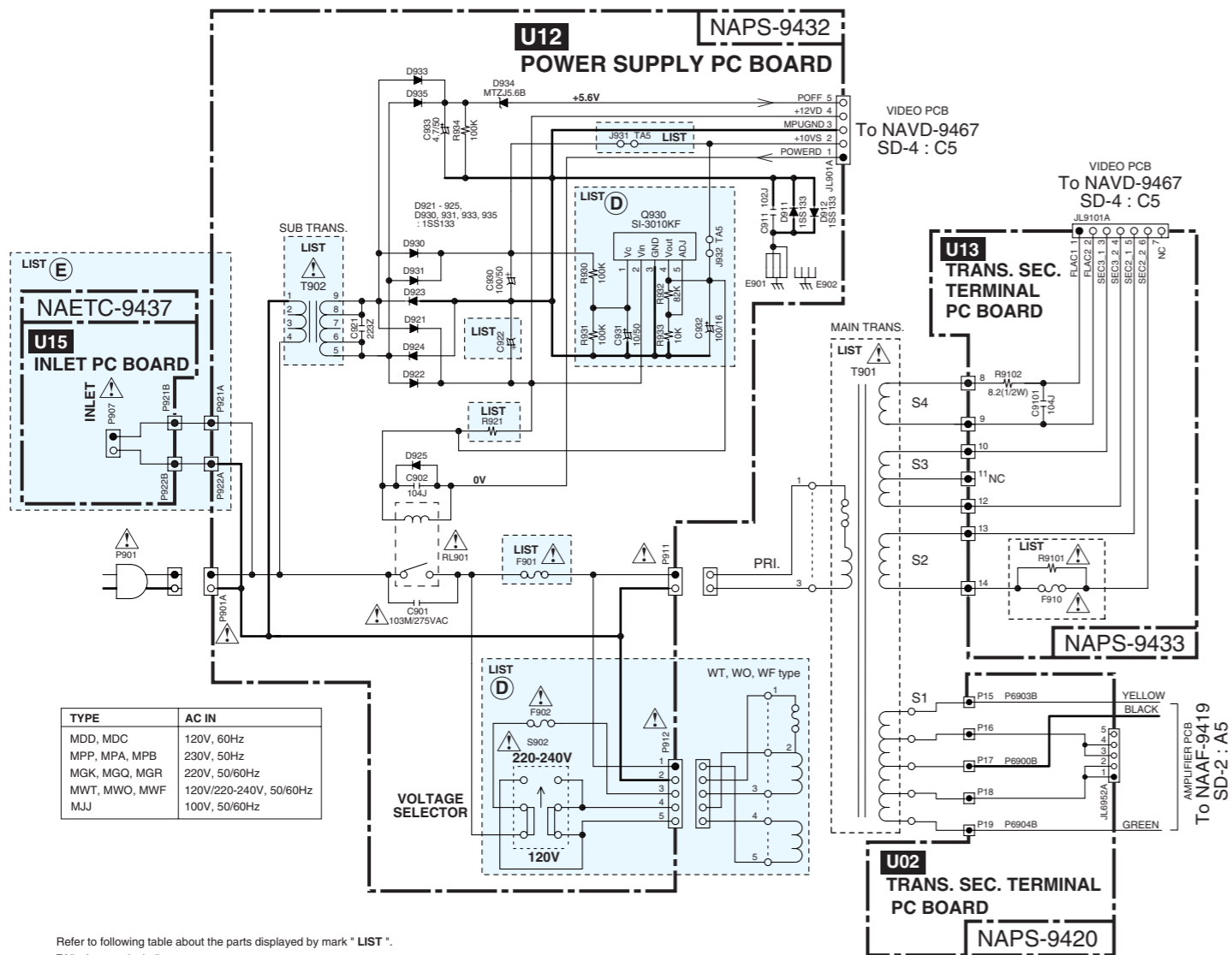

TYPE	AC IN
MDD, MDC	120V, 60Hz
MPP, MPA, MPB	230V, 50Hz
MGK, MGQ, MGR	220V, 50/60Hz
MWT, MWO, MWF	120V/220-240V, 50/60Hz
MJJ	100V, 50/60Hz

Refer to following table about the parts displayed by mark "LIST".
TA5 : Jumper wire L=5 mm

MODEL No. -->	TX-SR506				HT-R518		HT-R560		TX-SR576		HT-R667		HT-R960				TX-SR606				TX-SA606X			
TYPE -->	MDD, MDC	MPP, MPB	MGK, MGQ, MGR	MWT, MWO, MWF	MPP	MDD, MDC	MPP	MDD, MDC	MPP, MPA	MDD	MDC	MPP	MDD, MDC	MPP, MPB	MGK, MGQ, MGR	MWT, MWO, MWF	MJJ							
(D)	None	None	None	Yes	None	None	None	None	None	None	None	None	None	None	None	None	None	None						
(E)	None				None	None	None	None	None	None	None	None	None				None	Yes						
T901 NPT-	1516D	1516P	1516P	1516DG	1517P	1517D	1517P	1516D	1516P	1574D	1574D	1574P	1522D	1552P	1552G	1552DQ	1552J							
T902 NPT-	1520JQ	1520GQ	1520GQ	1520JQ	1520JQ	1520JQ	1520JQ	1520JQ	1520JQ	1520JQ	1520JQ	1520GQ	1520JQ	1520GQ	1520GQ	1520JQ	1520JQ							
C922	2200/25	2200/16	2200/35	2200/35	2200/16	2200/25	2200/16	2200/25	2200/16	2200/25	2200/25	2200/25	2200/25	2200/16	2200/16	2200/35	2200/16							
R921	47(1/2W)	47(1/2W)	None	47(1/2W)	47(1/2W)	47(1/2W)	47(1/2W)	47(1/2W)	47(1/2W)	47(1/2W)	47(1/2W)	47(1/2W)	47(1/2W)	47(1/2W)	47(1/2W)	47(1/2W)	47(1/2W)							
R9101	0.1(1/2W)	0.22(1/W)	0.22(1/W)	0.22(1/W)	0.1(1/2W)	0.22(1/W)	0.1(1/2W)	0.22(1/W)	0.1(1/2W)	0.1(1/2W)	0.1(1/2W)	0.1(1/2W)	0.1(1/2W)	0.1(1/2W)	0.1(1/2W)	0.1(1/2W)	0.1(1/2W)							
F901	8A/125V	4A/250V	4A/250V	8A/125V	4A/250V	8A/125V	4A/250V	8A/125V	4A/250V	8A/125V	4A/250V	8A/125V	4A/250V	10A/250V	5A/250V	12A/250V	12A/250V							
F902	None	None	4A/250V	None	None	None	None	None	None	None	None	None	None	None	5A/250V	None	None							
F910	None	None	None	None	None	None	None	None	None	None	None	None	None	5A/125V	5A/125V	5A/125V	5A/125V							
J931	Yes	None	None	Yes	Yes	Yes	Yes	Yes	Yes	Yes	Yes	Yes	Yes	Yes	None	None	Yes							

- NOTE**
- THE COMPONENTS IDENTIFIED BY MARK ARE CRITICAL FOR SAFETY REPLACE ONLY WITH PART NUMBER SPECIFIED.
 - VOLTAGE (MEASURED WITH VOLTMETER) IS DC VOLTAGE. (NO INPUT SIGNAL).
 - ALL PNP TRANSISTORS ARE EQUIVALENT TO 2SA1015-GR UNLESS OTHERWISE NOTED.
 - ALL NPN TRANSISTORS ARE EQUIVALENT TO 2SC1815-GR UNLESS OTHERWISE NOTED.
 - ALL DIODES ARE EQUIVALENT TO 1SS133 UNLESS OTHERWISE NOTED.
 - ELECTROLYTIC CAPACITORS () ARE IN uF/WV.
 - ALL CAPACITORS ARE IN pF/50WV UNLESS OTHERWISE NOTED. EX) 030-3pF 330-33pF 331-330pF 333-0.033uF
 - ALL RESISTORS ARE IN OHMS 1/4WATTS UNLESS OTHERWISE NOTED.
 - THE THICK LINES ON PC BOARD ARE THE PRINTING SIDE OF THE PARTS. EX) PRINTING SIDE
 - CIRCUIT IS SUBJECT TO CHANGE FOR IMPROVEMENT.

CAUTION
FOR CONTINUED PROTECTION AGAINST FIRE HAZARD, REPLACE ONLY WITH FUSE OF SAME TYPE AND RATING INDICATED.

ATTENTION
AFIN D'ASSURER UNE PROTECTION PERMANENTE CONTRE LES RISQUES D'INCENDIE, REMPLACER UNIQUEMENT PAR UN FUSIBLE DE MEME TYPE ET CALIBRATION COMME INDIQUE.

THIS SYMBOL LOCATED NEAR THE FUSE INDICATES THAT THE FUSE USED IS SLOW OPERATING TYPE FOR CONTINUED PROTECTION AGAINST FIRE HAZARD. REPLACE WITH SAME TYPE FUSE. FOR FUSE RATING REFER TO THE MARKING ADJACENT TO THE SYMBOL.

CE SYMBOLE INDIQUE QUE LE FUSIBLE UTILISE EST E LENT. POUR UNE PROTECTION PERMANENTE, UTILISER QUE DES FUSIBLES DE MEME TYPE. CE DERNIER EST INDIQUE LA QU LE PRESENT SYMBOLE EST APPOSE.

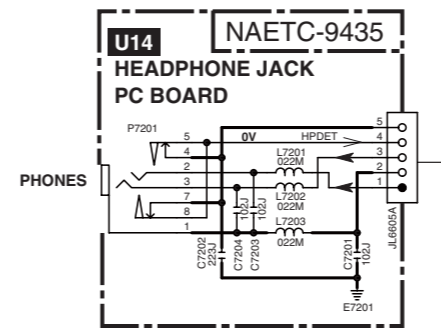

<Note>
1. NC = No mount of parts.
2. SD-x : XY is short for Schematic Diagrams-x and each sockets location, X = A to H, Y = 1 to 5.

AUDIO ANALOG SIGNAL
FRONT L
FRONT R

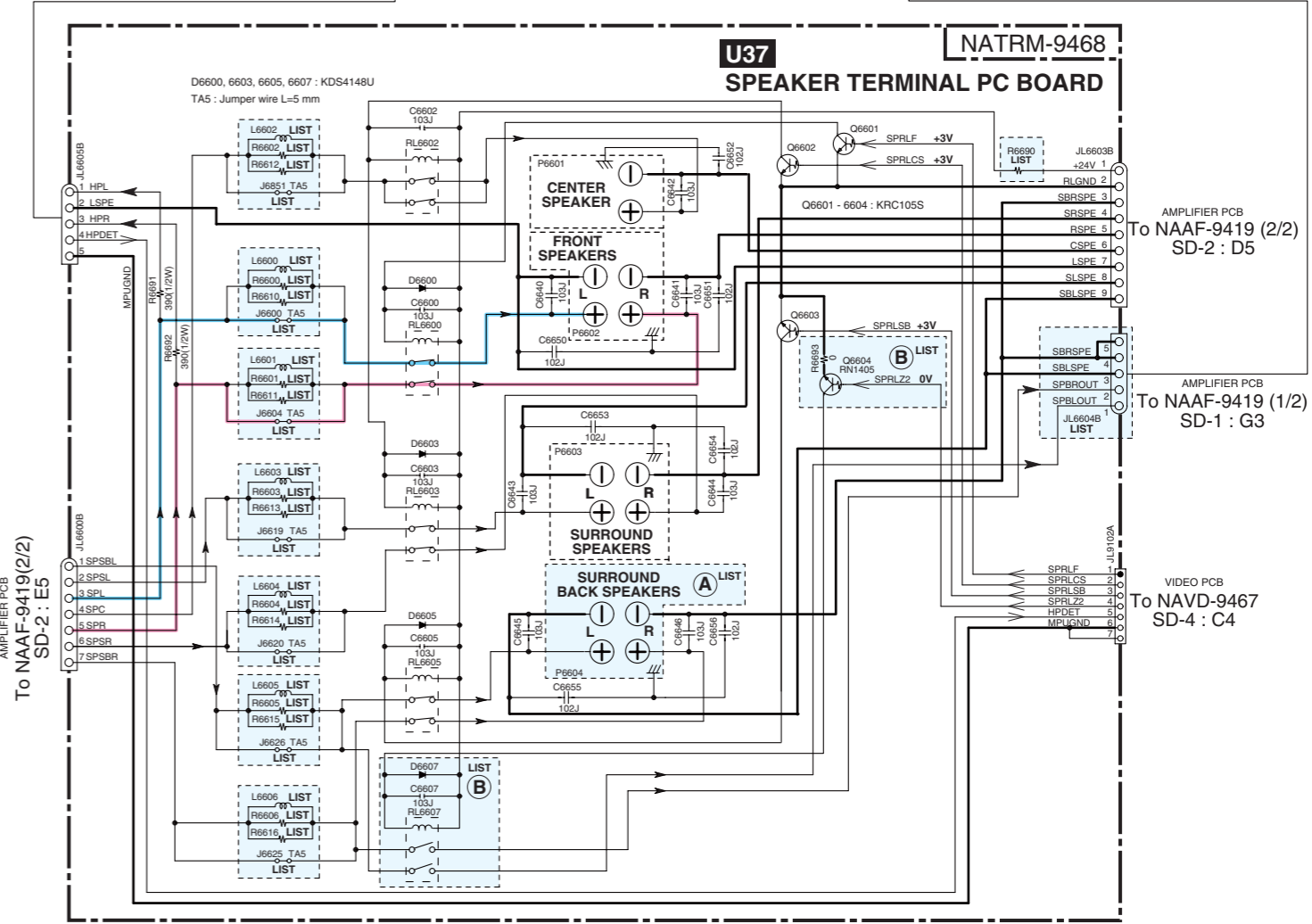

Refer to following table about the parts displayed by mark "LIST".

MODEL No. -->	TX-SR506				HT-R518		HT-R560		TX-SR576		HT-R667		HT-R960				TX-SR606				TX-SA606X			
TYPE -->	MDD, MDC	MPP, MPB	MGK, MGQ, MGR	MWT, MWO, MWF	MPP	MDD, MDC	MPP	MDD, MDC	MPP, MPA	MDD	MDC	MPP	MDD, MDC	MPP, MPB	MGK, MGQ, MGR	MWT, MWO, MWF	MJJ							
(A)	Yes	None	None	Yes	None	None	None	None	None	None	None	None	None	None	None	None	None							
(B)	None	None	None	None	None	None	None	None	None	None	None	None	None	None	None	None	None	Yes						
(C)	None	None	None	None	None	None	None	None	None	None	None	None	None	None	None	None	None	None						
L6600 - 6604	None	None	S-1.3C	S1.3C	None	S-1.3C	None	S-1.3C	None	S-1.3C	None	None	S-1.3C	None	None	S-1.3C	None	None						
L6605, 6606	None	None	S-1.3C	None	None	S-1.3C	None	S-1.3C	None	S-1.3C	None	None	S-1.3C	None	None	S-1.3C	None	None						
R6600 - 6606, R6610 - 6616	None	None	22	None	22	None	22	None	22	None	22	None	22	None	22	None	22	None						
R6605, 6606, R6615, 6616	None	None	22	None	None	22	None	22	None	22	None	None	22	None	22	None	22	None						
R6690	10(1/2W)	33(1/2W)	33(1/2W)	10(1/2W)	33(1/2W)	33(1/2W)	10(1/2W)	33(1/2W)	33(1/2W)	10(1/2W)	33(1/2W)	33(1/2W)	10(1/2W)	33(1/2W)	33(1/2W)	10(1/2W)	10(1/2W)							
J6600, 6604, J6619, 6620, J6625, 6626, 6651	TA5	None	None	None	None	None	None	None	None	None	None	None	None	None	None	None	None	None						
JL6604B	Yes	None	None	Yes	None	Yes	None	Yes	None	Yes	None	Yes	None	Yes	None	Yes	None	Yes						

5

SCHEMATIC DIAGRAMS-6 (SD-6) DISPLAY SECTION

1

NOTE

- THE COMPONENTS IDENTIFIED BY MARK \triangle ARE CRITICAL FOR SAFETY. REPLACE ONLY WITH PART NUMBER SPECIFIED.
- VOLTAGE (MEASURED WITH VOLTMETER) \square IS DC VOLTAGE (NO INPUT SIGNAL).
- ALL PNP TRANSISTORS ARE EQUIVALENT TO 2SA1015-GR UNLESS OTHERWISE NOTED.
- ALL NPN TRANSISTORS ARE EQUIVALENT TO 2SC1815-GR UNLESS OTHERWISE NOTED.
- ALL DIODES ARE EQUIVALENT TO 1SS133 UNLESS OTHERWISE NOTED.
- ELECTROLYTIC CAPACITORS (\square) ARE IN μ FVV.
- ALL CAPACITORS ARE IN pF/ \square UNLESS OTHERWISE NOTED.
EX) 030-3pF 330-33pF 331-330pF 333-0.033uF
- ALL RESISTORS ARE IN OHMS 1/4WATTS UNLESS OTHERWISE NOTED.
- THE THICK LINES ON PC BOARD ARE THE PRINTING SIDE OF THE PARTS.
EX) \square PRINTING SIDE
- CIRCUIT IS SUBJECT TO CHANGE FOR IMPROVEMENT.

<Note>

1. NC = No mount of parts.
2. SD-x : XY is short for Schematic Diagrams-x and each sockets location, X = A to H, Y = 1 to 5.
3. Refer to SCHEMATIC DIAGRAMS-12 (SD-12) for FL driver IC control waveform.

2

3

4

5

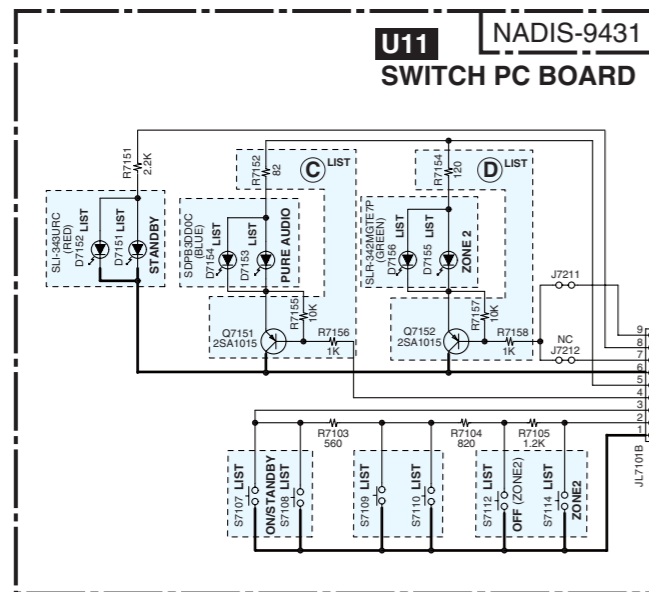

Refer to following table about the parts displayed by mark * LIST *.

MODEL No.→	TX-SR506		HT-R518	HT-R560	TX-SR576	HT-R667	HT-R960	TX-SR606	TX-SA606X		
TYPE→	MDD, MDC	MPP, MGK, MW, MPB, MGQ, MWO, MGR, MWV	MPP	MDD, MPP, MDC	MDD, MDC	MPP, MPA	MDD	MDC, MPP	MDD, MDC	MPP, MGK, MPA, MGO, MWO, MPB, MGR, MWV	MJJ
(A)		Yes	Yes	Yes	Yes	Yes	Yes	None	None	None	None
(B)		None	None	None	None	None	None	Yes	Yes	None	Yes
(C)		None	Yes	None	None	Yes	None	None	Yes	None	Yes
(D)		Yes	None	None	Yes	None	None	Yes	None	None	None
D7151		Yes	Yes	Yes	Yes	Yes	Yes	None	None	None	None
D7152		None	None	None	None	None	None	Yes	Yes	None	Yes
D7153		None	Yes	None	None	Yes	None	None	None	None	None
D7154		None	None	None	None	None	None	None	Yes	None	Yes
D7155		None	None	None	None	None	None	Yes	None	None	None
D7156		Yes	None	None	Yes	None	None	None	None	None	None
S7001, S7107		Yes	Yes	Yes	Yes	Yes	Yes	None	None	None	None
S7002, S7108		None	None	None	None	None	None	Yes	Yes	None	Yes
S7109	MUSIC OPTIMIZER	PURE AUDIO	PURE AUDIO	DOCK	MUSIC OPTIMIZER	PURE AUDIO	DOCK	THX	None	None	None
S7110		None	None	None	None	None	None	PURE AUDIO	PURE AUDIO	None	PURE AUDIO
S7112, S7114		None	None	None	None	None	None	Yes	None	None	None

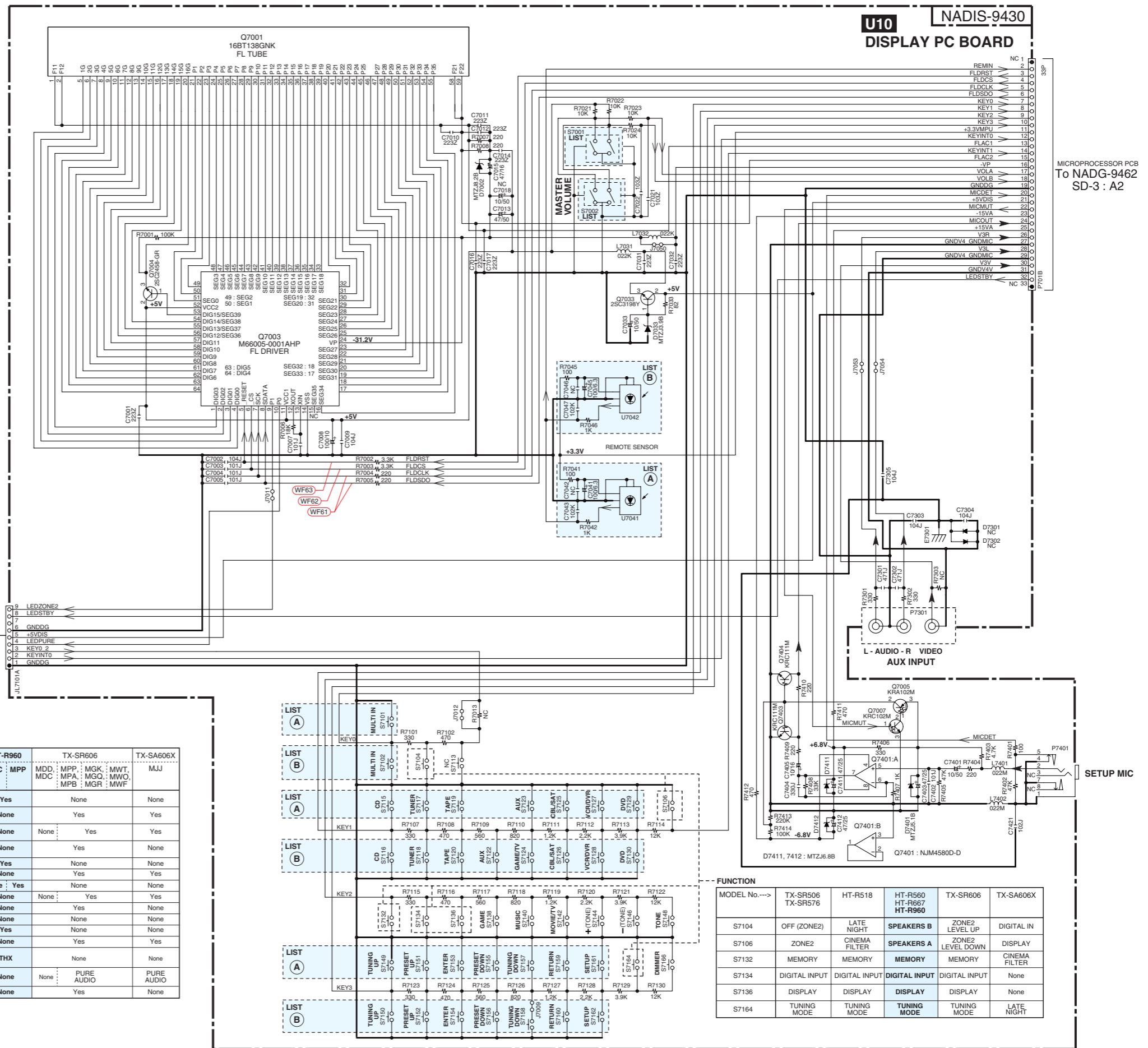

FUNCTION

MODEL No.→	TX-SR506 TX-SR576	HT-R518	HT-R560 HT-R667 HT-R960	TX-SR606	TX-SA606X
S7104	OFF (ZONE2)	LATE NIGHT	SPEAKERS B	ZONE2 LEVEL UP	DIGITAL IN
S7106	ZONE2	CINEMA FILTER	SPEAKERS A	ZONE2 LEVEL DOWN	DISPLAY
S7132	MEMORY	MEMORY	MEMORY	MEMORY	CINEMA FILTER
S7134	DIGITAL INPUT	DIGITAL INPUT	DIGITAL INPUT	DIGITAL INPUT	None
S7136	DISPLAY	DISPLAY	DISPLAY	DISPLAY	None
S7164	TUNING MODE	TUNING MODE	TUNING MODE	TUNING MODE	LATE NIGHT

SCHEMATIC DIAGRAMS-7 (SD-7)

DSP SECTION

1
2
3
4
5

NAHDM-9473 (1/3)

U41

HDMI PC BOARD

DSP / HDMI PCB
To HDMI SECTION
NAHDM-9473 (2/3)
SD-8 : H1

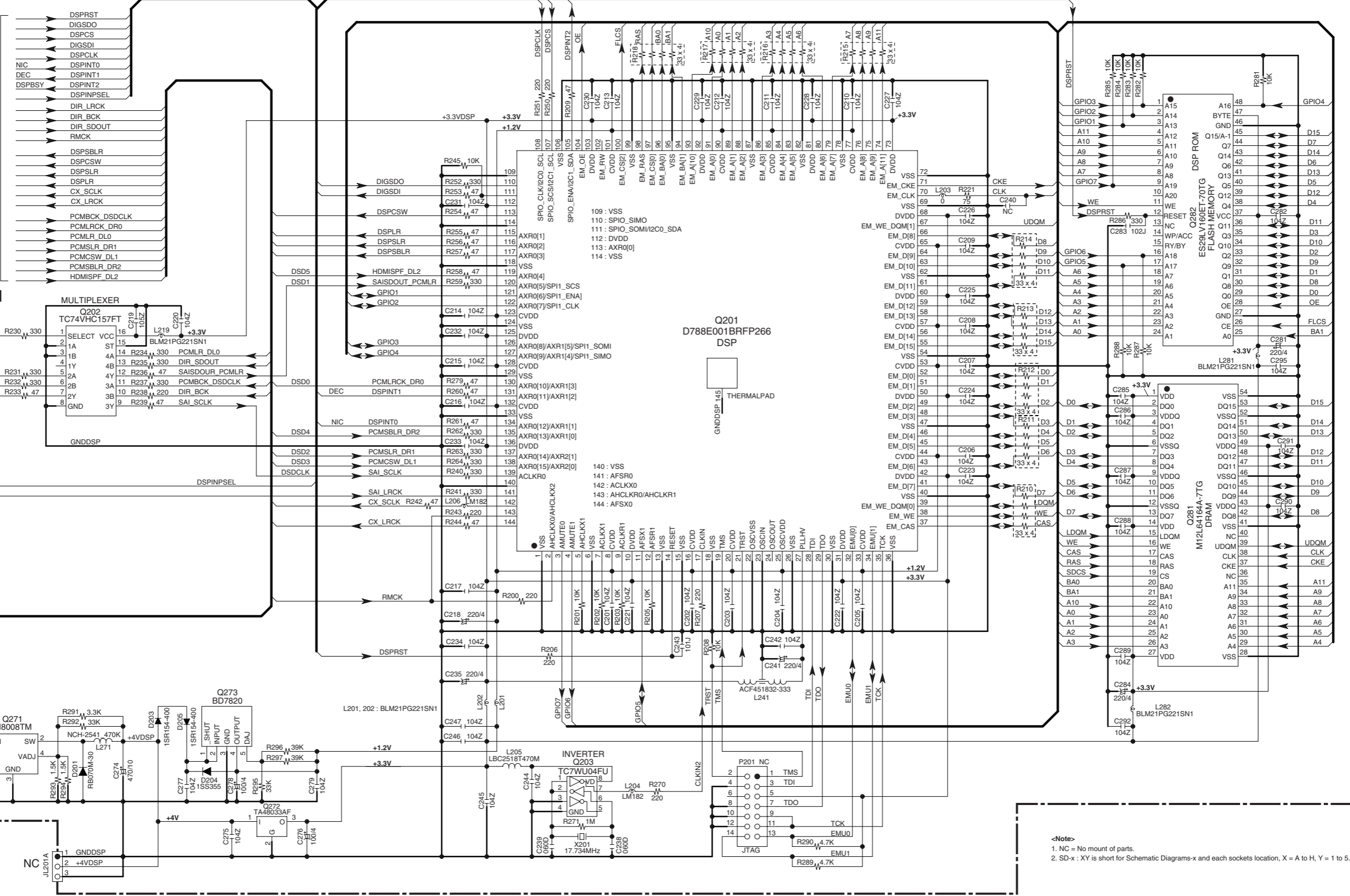

<Note>
1. NC = No mount of parts.
2. SD-x : XY is short for Schematic Diagrams-x and each sockets location, X = A to H, Y = 1 to 5.

SCHEMATIC DIAGRAMS-8 (SD-8) HDMI SECTION

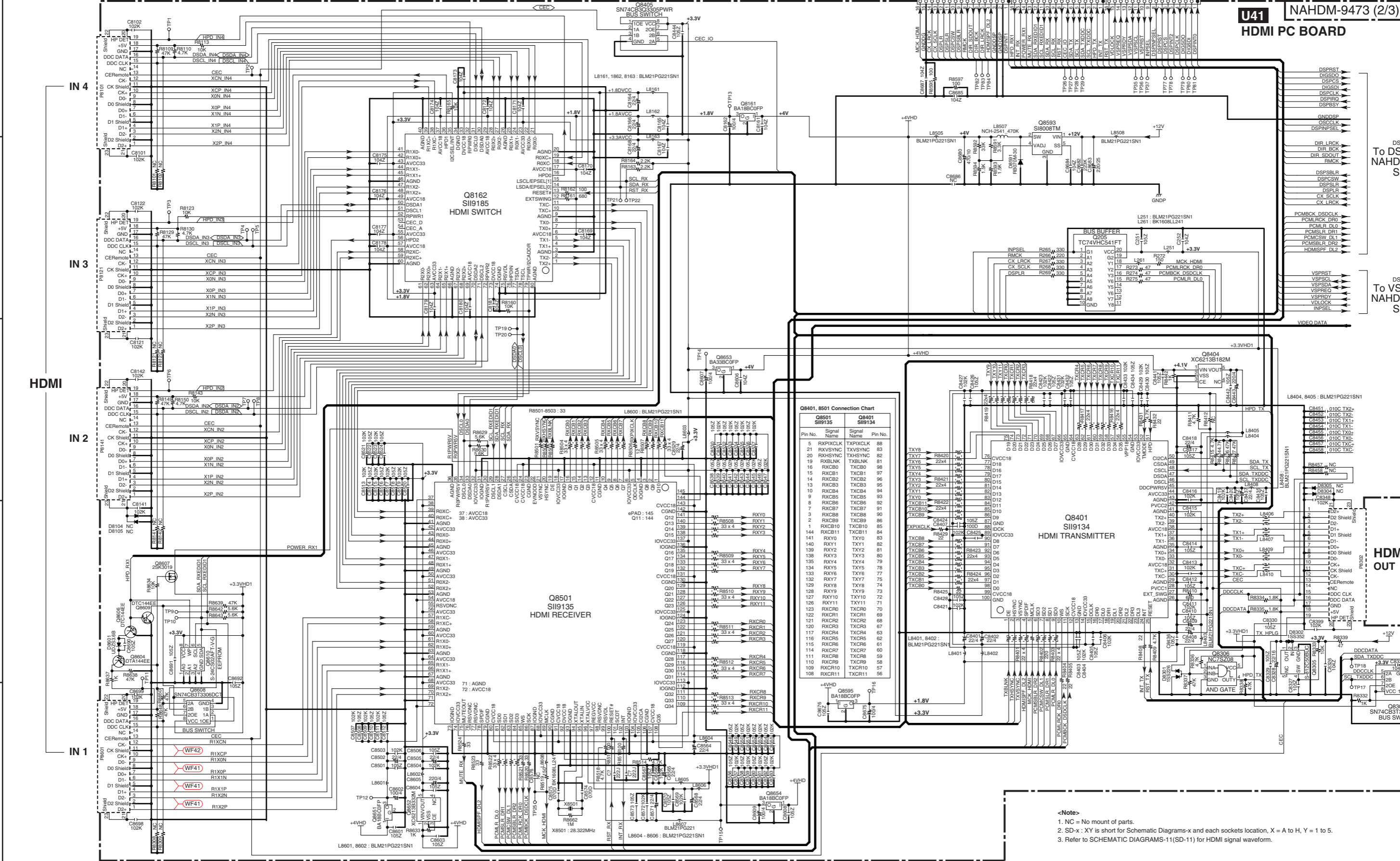

Q8401, 8501 Connection Chart

Q8501 Pin No.	Signal Name	Q8401 Pin No.	Signal Name
5	RXP1XCLK	88	TXP1XCLK
21	RXV5VNC	83	TXV5VNC
20	RXHSYNC	82	TXHSYNC
19	RXBLNK	81	TXBLNK
16	RXC80	80	TXC80
15	RXC81	79	TXC81
14	RXC82	78	TXC82
13	RXC83	77	TXC83
10	RXC84	74	TXC84
9	RXC85	73	TXC85
8	RXC86	72	TXC86
7	RXC87	71	TXC87
3	RXC88	68	TXC88
2	RXC89	67	TXC89
1	RXC90	66	TXC90
144	RXC91	65	TXC91
140	RXY0	84	TXY0
139	RXY1	82	TXY1
138	RXY2	81	TXY2
137	RXY3	80	TXY3
136	RXY4	79	TXY4
135	RXY5	78	TXY5
134	RXY6	77	TXY6
133	RXY7	76	TXY7
132	RXY8	75	TXY8
129	RXY9	74	TXY9
128	RXY10	73	TXY10
127	RXY11	72	TXY11
126	RXY12	71	TXY12
123	RXC92	70	TXC92
122	RXC93	69	TXC93
121	RXC94	68	TXC94
120	RXC95	67	TXC95
117	RXC96	64	TXC96
116	RXC97	63	TXC97
115	RXC98	62	TXC98
114	RXC99	61	TXC99
110	RXC100	58	TXC100
109	RXC101	57	TXC101
108	RXC102	56	TXC102

<Note>
 1. NC = No mount of parts.
 2. SD-x : XY is short for Schematic Diagrams-x and each sockets location, X = A to H, Y = 1 to 5.
 3. Refer to SCHEMATIC DIAGRAMS-11(SD-11) for HDMI signal waveform.

SCHEMATIC DIAGRAMS-9 (SD-9) VSP (Video Signal Processor) SECTION

U41 NAHDM-9473 (3/3)
DSP / HDMI PC BOARD

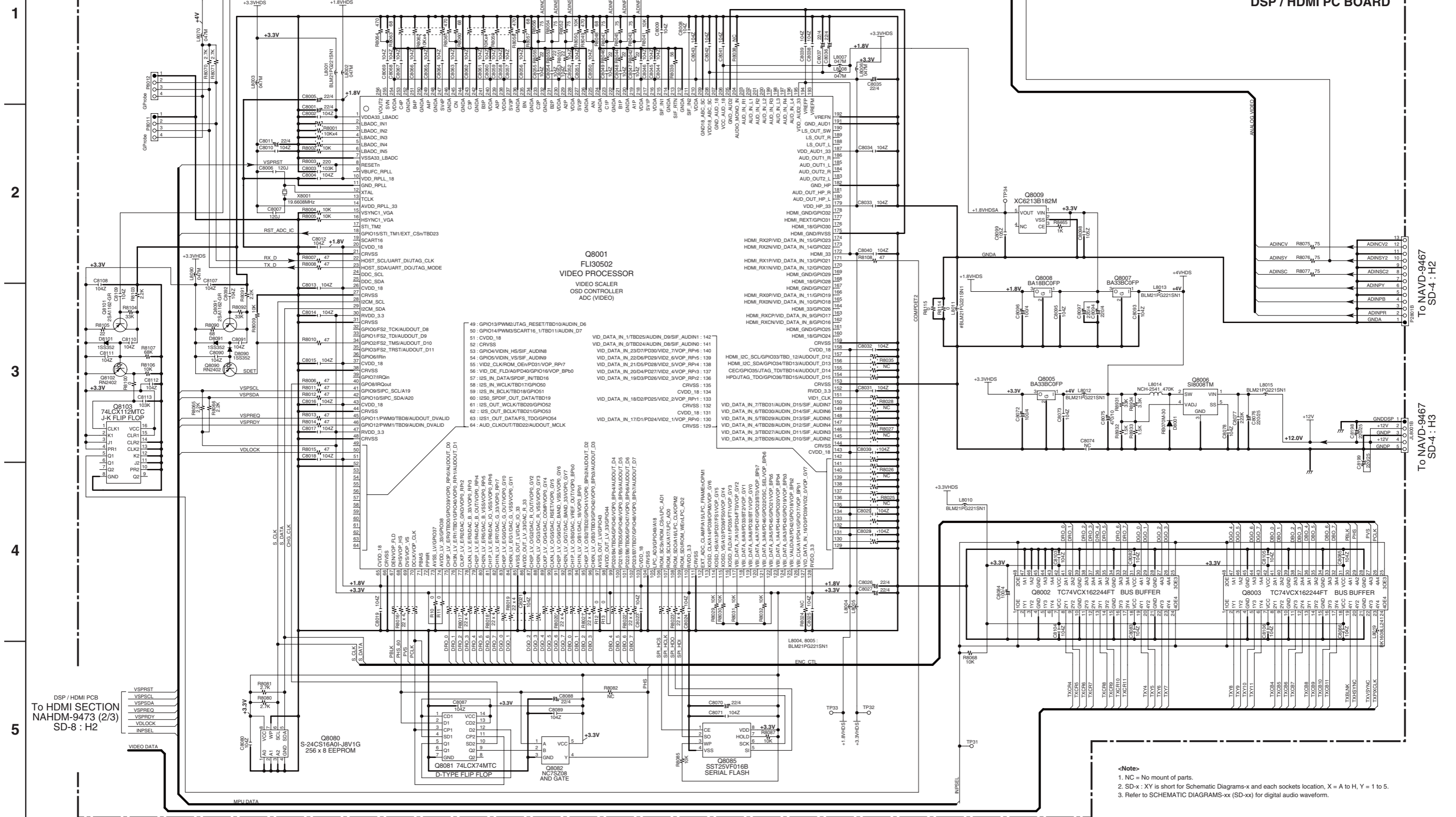

<Note>
 1. NC = No mount of parts.
 2. SD-x : XY is short for Schematic Diagrams-x and each sockets location, X = A to H, Y = 1 to 5.
 3. Refer to SCHEMATIC DIAGRAMS-xx (SD-xx) for digital audio waveform.

A

B

C

D

SCHEMATIC DIAGRAMS-10

WAVEFORM SECTION-1/3

Digital Audio Waveform Part

1

<Notes>

1. (WF01) is short for Waveform-01 .
2. Refer to SD-3 (SCHEMATIC DIAGRAMS-3) for the location of each waveform on circuit.
3. SD-x : XY is short for Schematic Diagrams-x and each socket's location, X=A to H, Y=1 to 5.

LR CLOCK (SAI_LRCK, CX_LRCK)

Fs = 48kHz : DVD, Clock width = 20.8 μ s

Fs = 44.1kHz : CD, Clock width = 22.7 μ s

BIT CLOCK (SAI_SLCK, CX_SLCK)

64Fs = 3072kHz : DVD, Clock width = 325ns

64Fs = 2822.4kHz : CD, Clock width = 354ns

2

(WF01) OPT1 (SD-3 : D5)

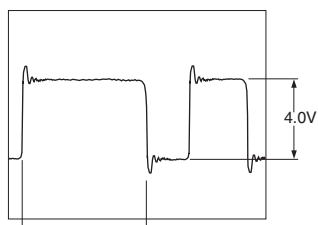

Duty varies according to audio data

(WF02) COAX1 (SD-3 : D5)

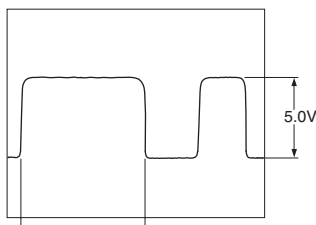

Duty always varies according to audio data

(WF03) SAI_SDOUT (SD-3 : E4)

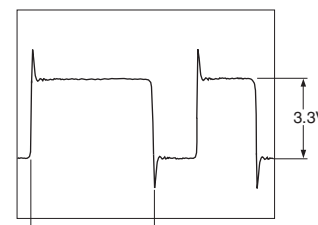

Duty varies according to audio data

3

(WF04) SAI_LRCK (SD-3 : E4)

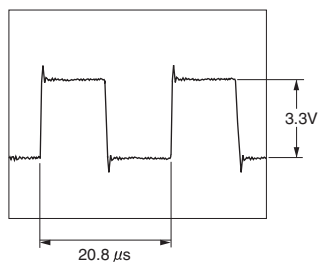

(WF05) SAI_SLCK (SD-3 : E4)

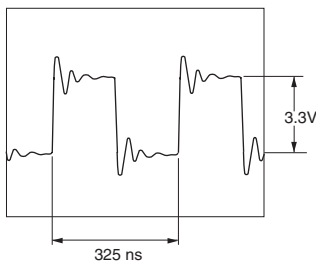

(WF06) CX_SDIN1 (SD-3 : E4)

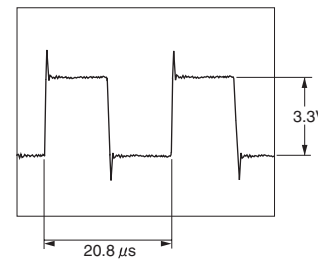

4

(WF07) CX_LRCK (SD-3 : E4)

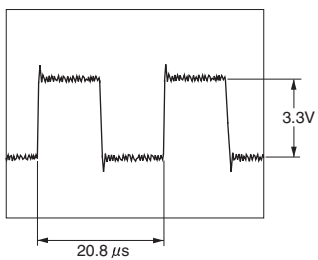

(WF08) CX_SCLK (SD-3 : E4)

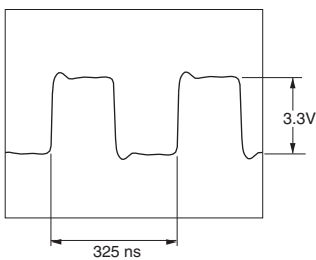

(WF09) DAC_OUT- (SD-3 : C5)

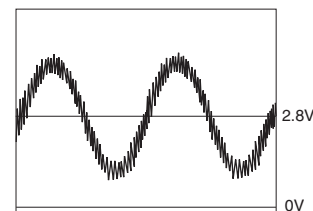

Analog audio waveform with aliasing noise

5

(WF10) AUDIO_FL (SD-3 : B5)

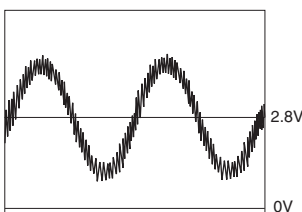

Analog audio waveform with aliasing noise

(WF10) AUDIO_FL (SD-3 : B5)

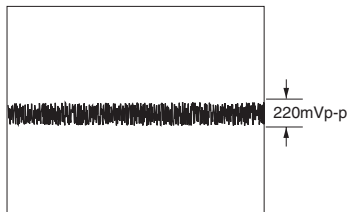

Aliasing noise in no audio data

A

B

C

D

SCHEMATIC DIAGRAMS-11

WAVEFORM SECTION-2/3

Video Waveform Part

1

<Notes>

1. (WF21) is short for Waveform-21 .
2. Refer to SD-4 (SCHEMATIC DIAGRAMS-4) for the location of each waveform on circuit.
3. SD-x : XY is short for Schematic Diagrams-x and each socket's location, X=A to H, Y=1 to 5.
4. In the case that video outputs are not connected to video devices, video signal output levels are doubled.

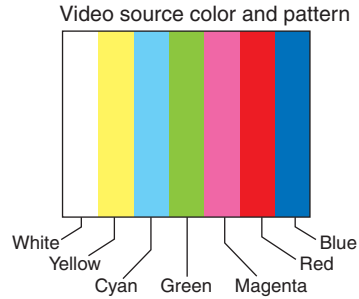

2

Composite waveform

(WF21) (SD-4 : B4)

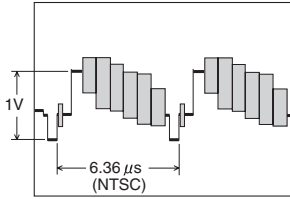

1.2 Vp-p (H)

S-Video Y waveform

(WF22) (SD-4 : B4)

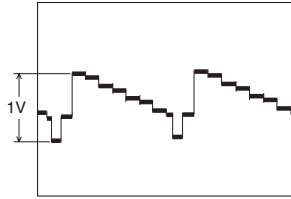

1.0 Vp-p

S-Video C waveform

(WF23) (SD-4 : B4)

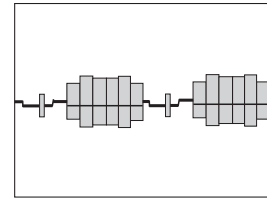

280 mVp-p

3

Component Y waveform

(WF24) (SD-4 : B2)

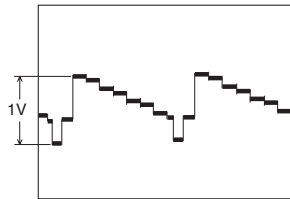

1.0 Vp-p

Component PB waveform

(WF25) (SD-4 : B2)

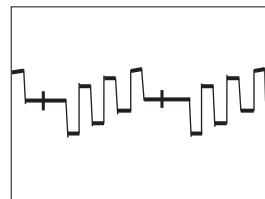

720 mVp-p

Component PR waveform

(WF21) (SD-4 : B2)

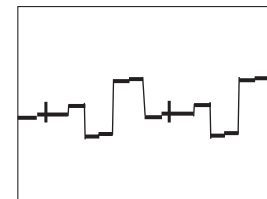

728 mVp-p

HDMI Waveform Part

<Notes>

1. (WF41) is short for Waveform-41 .
2. Refer to SD-8 (SCHEMATIC DIAGRAMS-8) for the location of each waveform on circuit.
3. SD-x : XY is short for Schematic Diagrams-x and each socket's location, X=A to H, Y=1 to 5.

4

HDMI D0,D1,D2 waveform

(WF41) SD-8 : B5

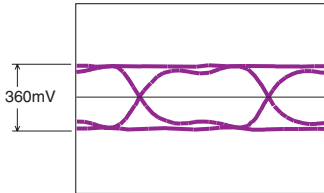

2,227.5MHz
(1080p, 12bit)

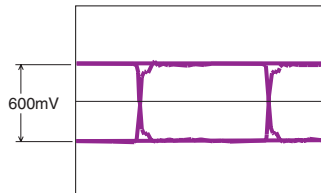

27MHz
(480i, 8bit)

D0,D1,D2 Eye-pattern waveform, frequency and level vary according to video resolution, aspect and profile. Waveforms above are examples.

5

HDMI CK waveform

(WF42) SD-8 : B5

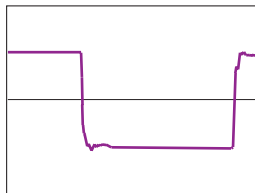

222.75MHz
(1080p, 12bit)

CK waveform, frequency and level differ according to video resolution, aspect and profile. D0,D1,D2 are just CK x10.

A

B

C

D

SCHEMATIC DIAGRAMS-12

WAVEFORM SECTION-3/3

FL Driver IC Control Waveform Part

1

<Notes>

1. (WF61) is short for Waveform-61 .
2. Refer to SD-6 (SCHEMATIC DIAGRAMS-6) for the location of each waveform on circuit.
3. SD-x : XY is short for Schematic Diagrams-x and each socket's location, X=A to H, Y=1 to 5.

2

SCK/SDATA waveform
(WF61) SD-6 : D3

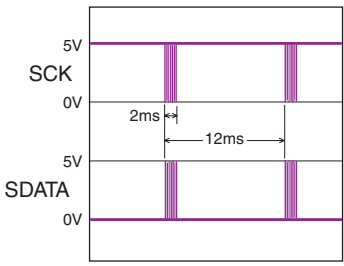

SCK/SDATA waveform
(WF61) SD-6 : D3

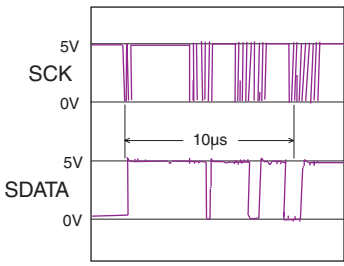

SDATA waveform varies according to the data content

3

SCK/CS waveform
(WF62) SD-6 : D3

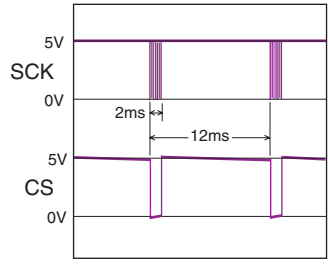

4

SCK/RESET waveform
(WF63) SD-6 : D3

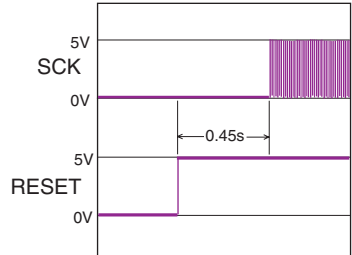

When power on

SCK/RESET waveform
(WF63) SD-6 : D3

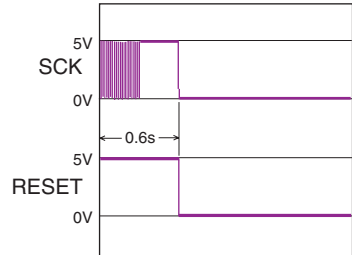

When power off

5

A B C D E F G H
PRINTED CIRCUIT BOARD VIEWS-1

U05 AMPLIFIER PC BOARD
(NAAF-9424)

Component side

1

2

3

4

5

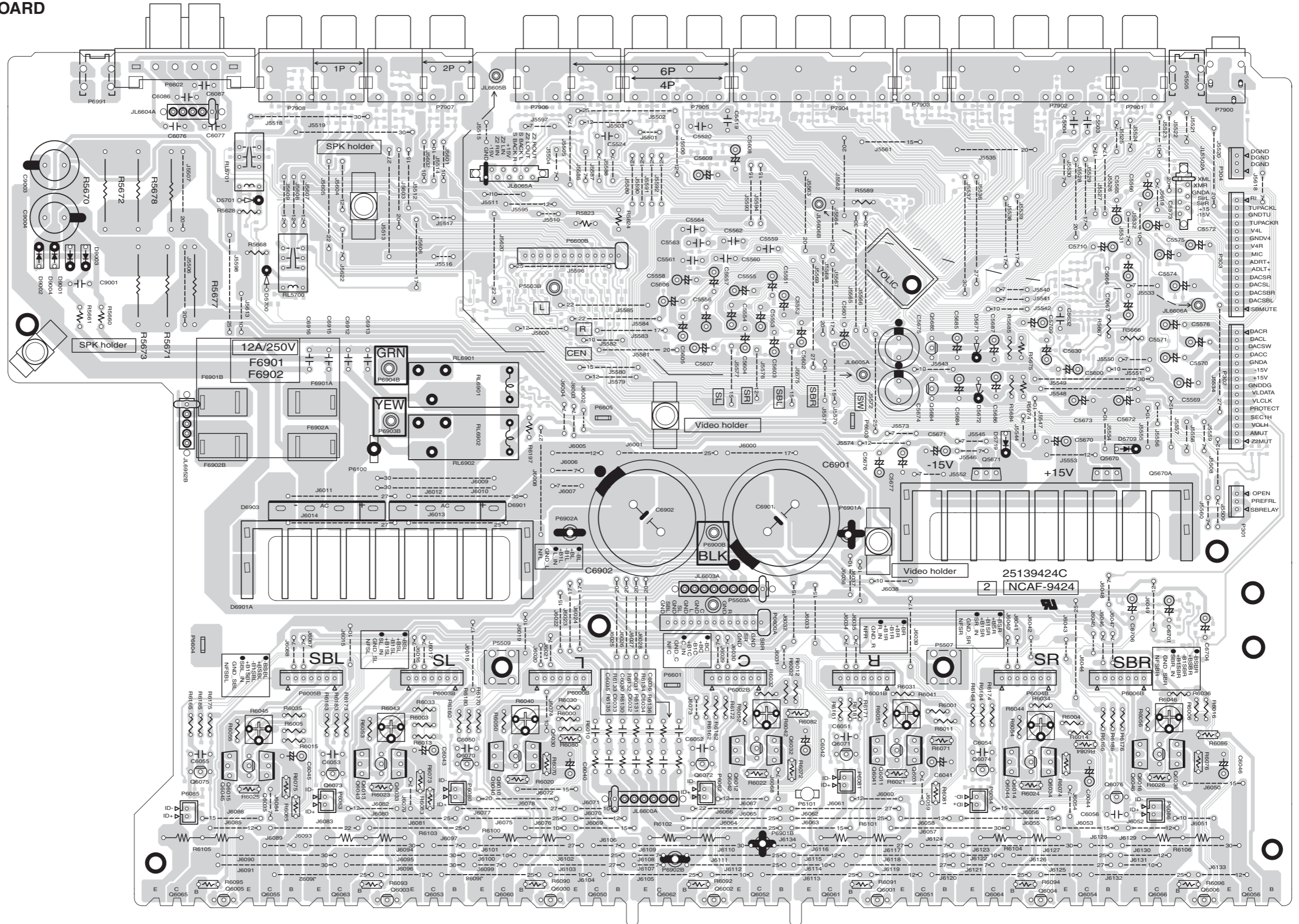

A B C D E F G H
PRINTED CIRCUIT BOARD VIEWS-2

U05 AMPLIFIER PC BOARD (NAAF-9424)
Soldering side

1
2
3
4
5

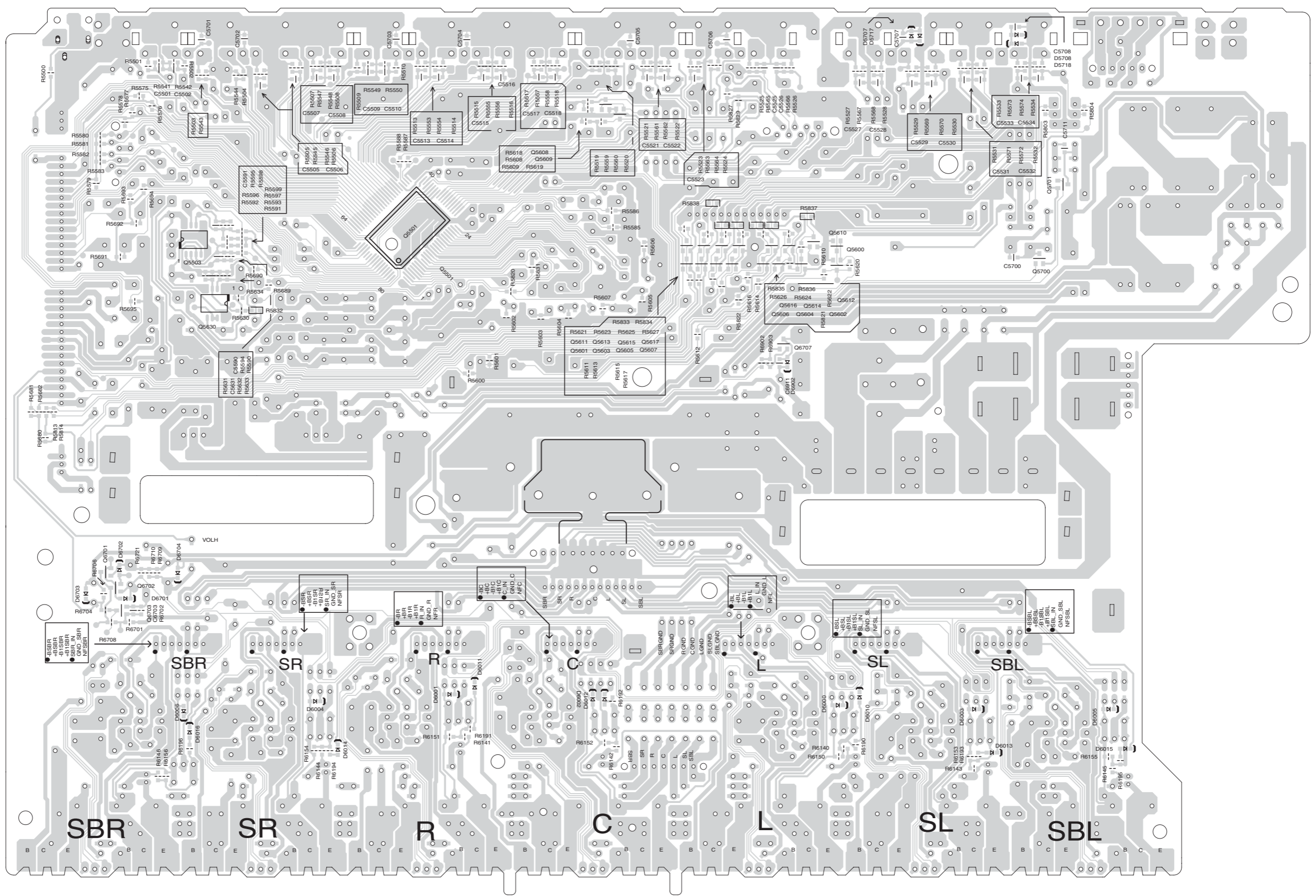

A

B

C

D

PRINTED CIRCUIT BOARD VIEWS-3

1

U07 THERMAL SENSOR PC BOARD (NAETC-9426)

Component side

Soldering side

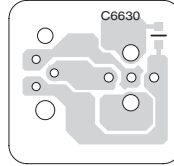
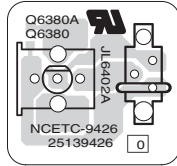

2

U06 TRANS. SEC. TERMINAL PC BOARD (NAPS-9425)

Component side

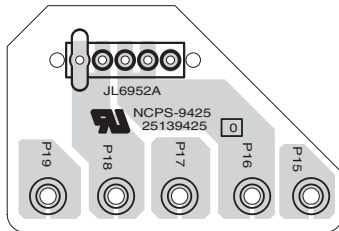

3

U09 ZONE 2 SPEAKER TERMINAL PC BOARD (NATRM-9428)

Component side

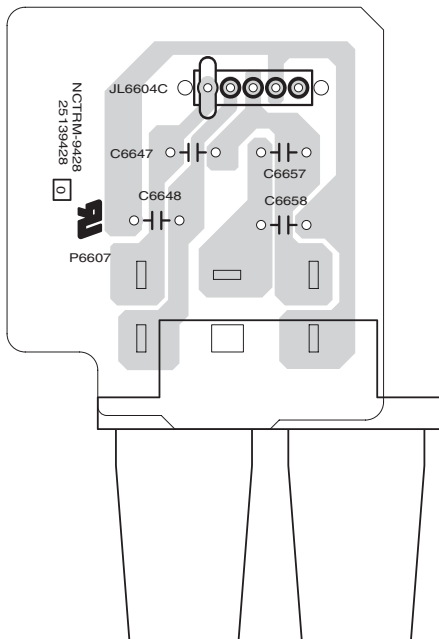

5

A B C D E F G H

PRINTED CIRCUIT BOARD VIEWS-4

U10 DISPLAY PC BOARD (NADIS-9430)

Component side

1

2

3

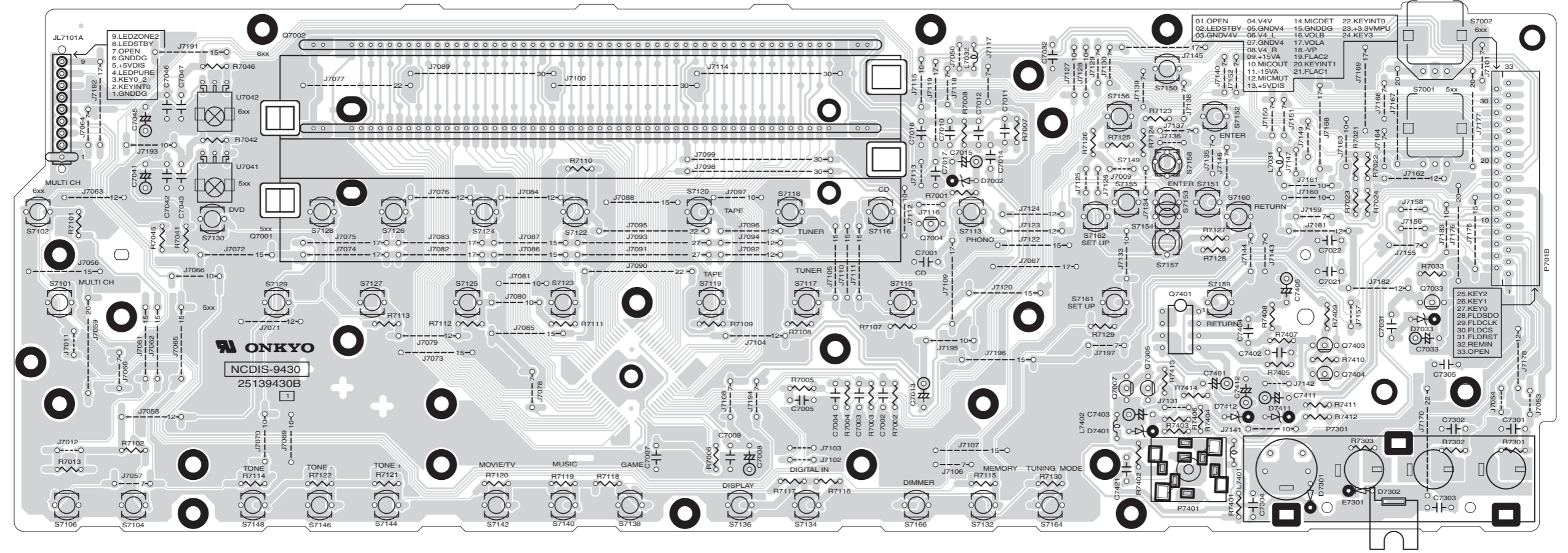

U11 SWITCH PC BOARD (NADIS-9431)

Component side

4

5

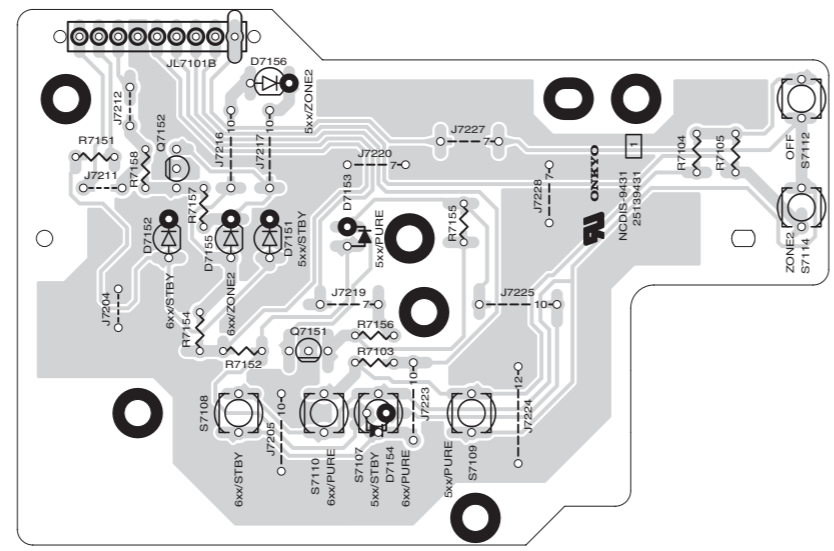

A B C D

PRINTED CIRCUIT BOARD VIEWS-5

U12 POWER SUPPLY PC BOARD (NAPS-9432)

Component side

1

2

3

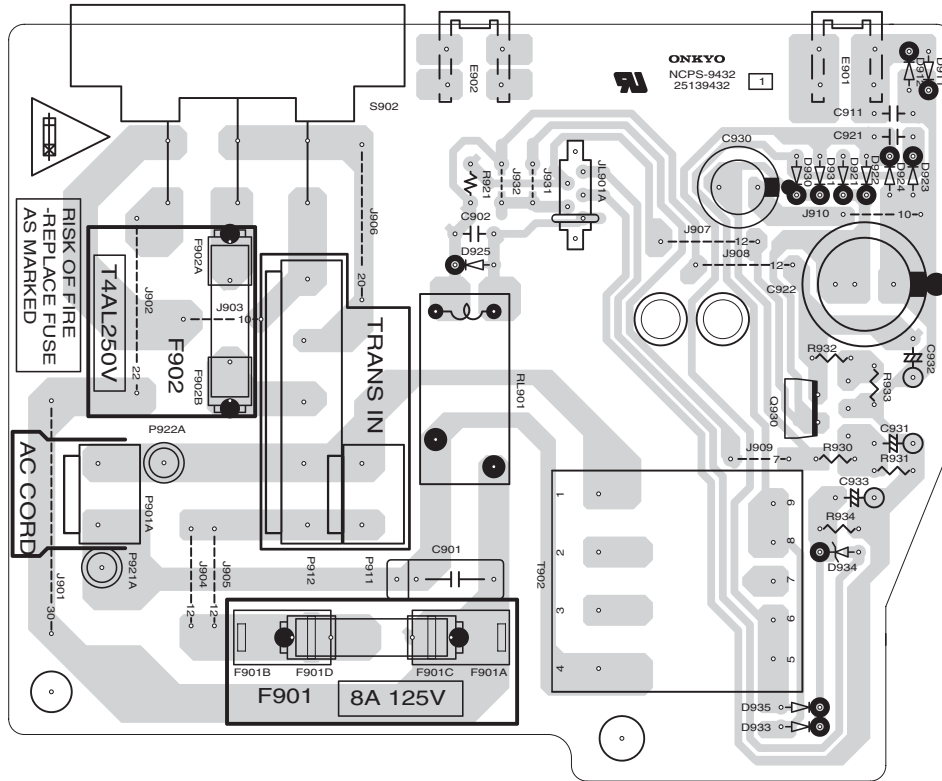

U13 TRANS. SEC. TERMINAL PC BOARD (NAPS-9433)

Component side

4

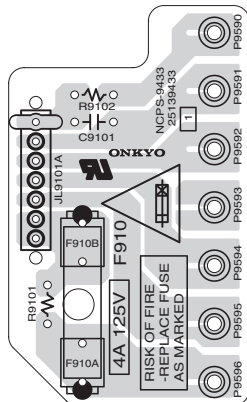

5

U14 HEADPHONE JACK PC BOARD (NAETC-9435)

Component side

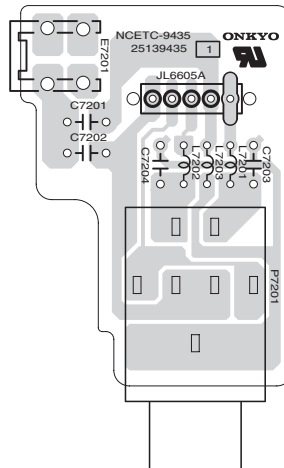

U18 HOLDER PC BOARD (NAETC-9442)

Component side

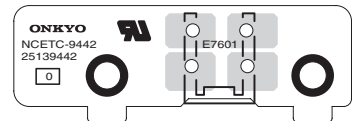

A B C D

PRINTED CIRCUIT BOARD VIEWS-6

U32 MICROPROCESSOR PC BOARD (NADG-9462)

Side-A

1

2

3

4

5

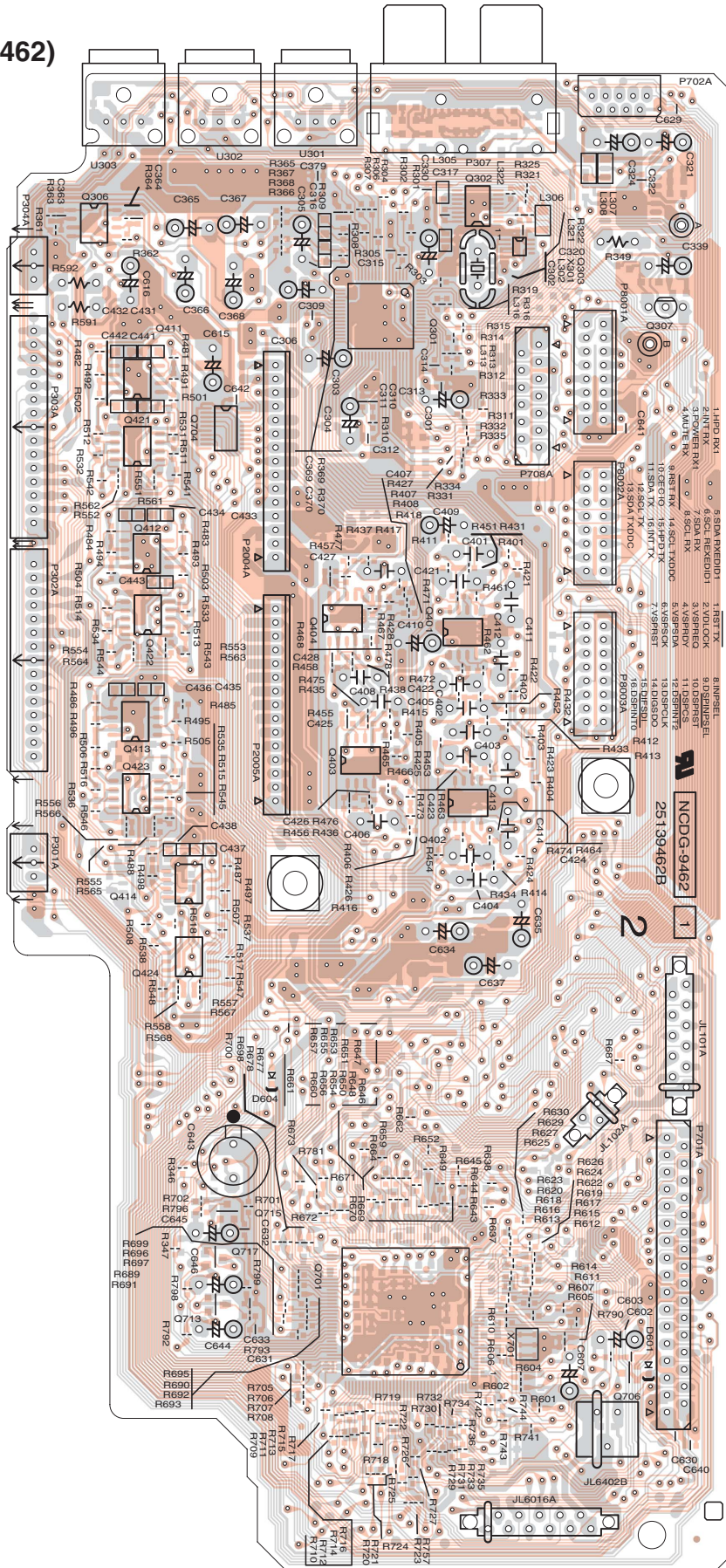

A

B

C

D

PRINTED CIRCUIT BOARD VIEWS-7

U32 MICROPROCESSOR
PC BOARD (NADG-9462)

Side-B

1

2

3

4

5

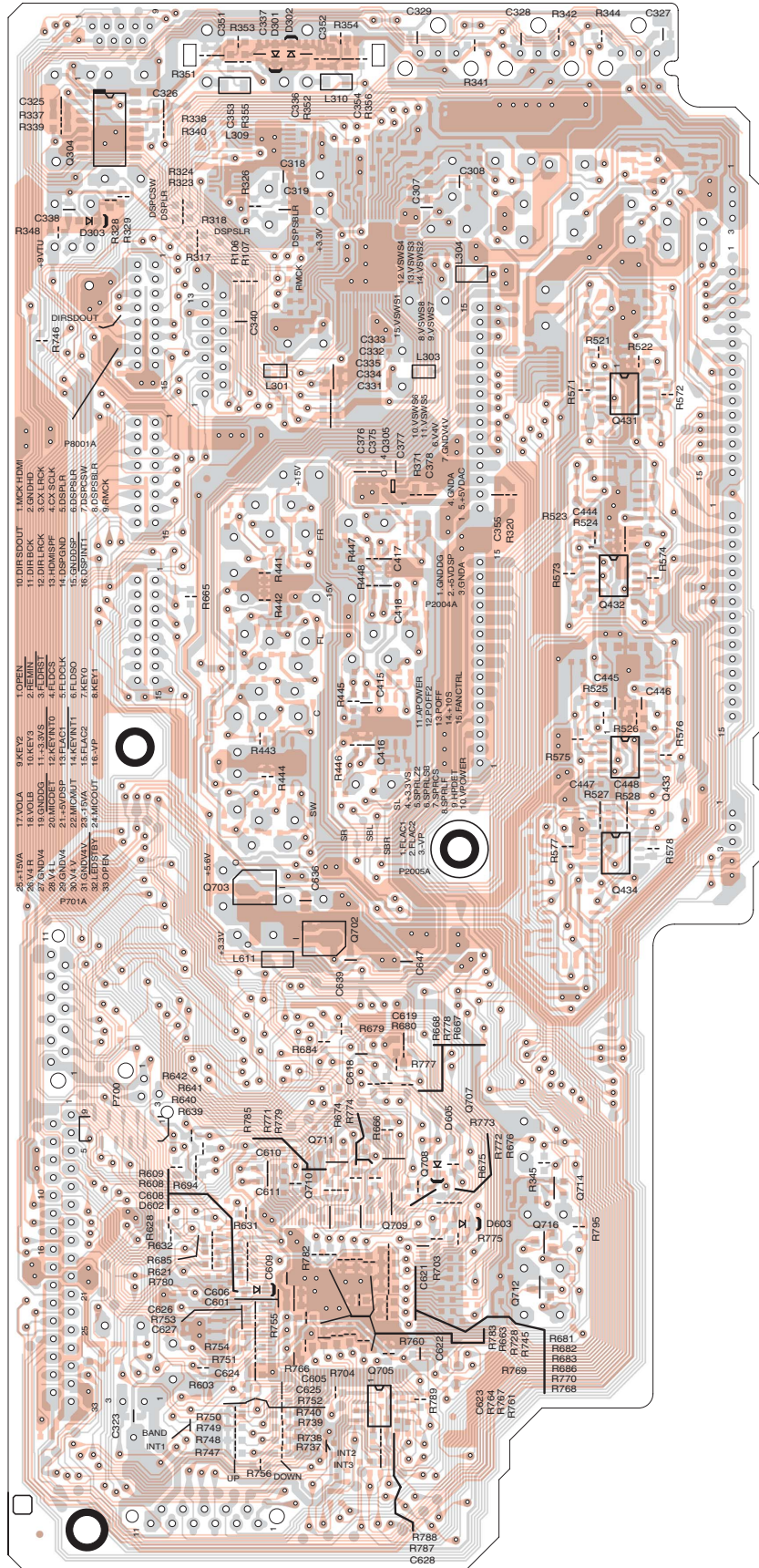

A

B

C

D

PRINTED CIRCUIT BOARD VIEWS-8

U33 SIRIUS / DOCK TERMINAL PC BOARD (NARF-9463)

Side-A

1

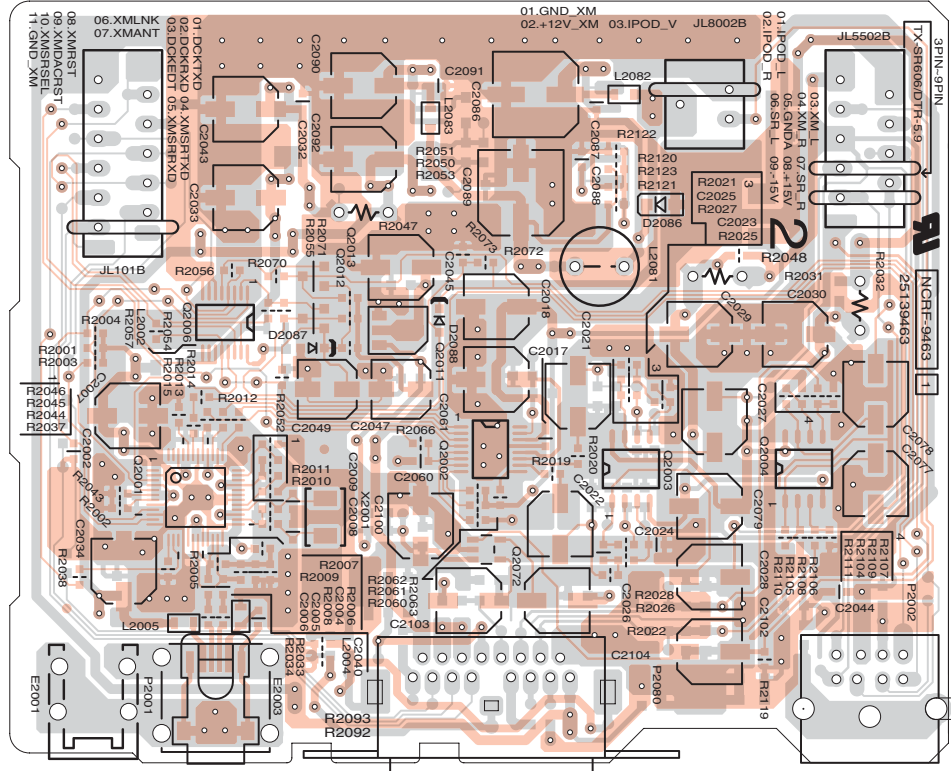

2

3

Side-B

4

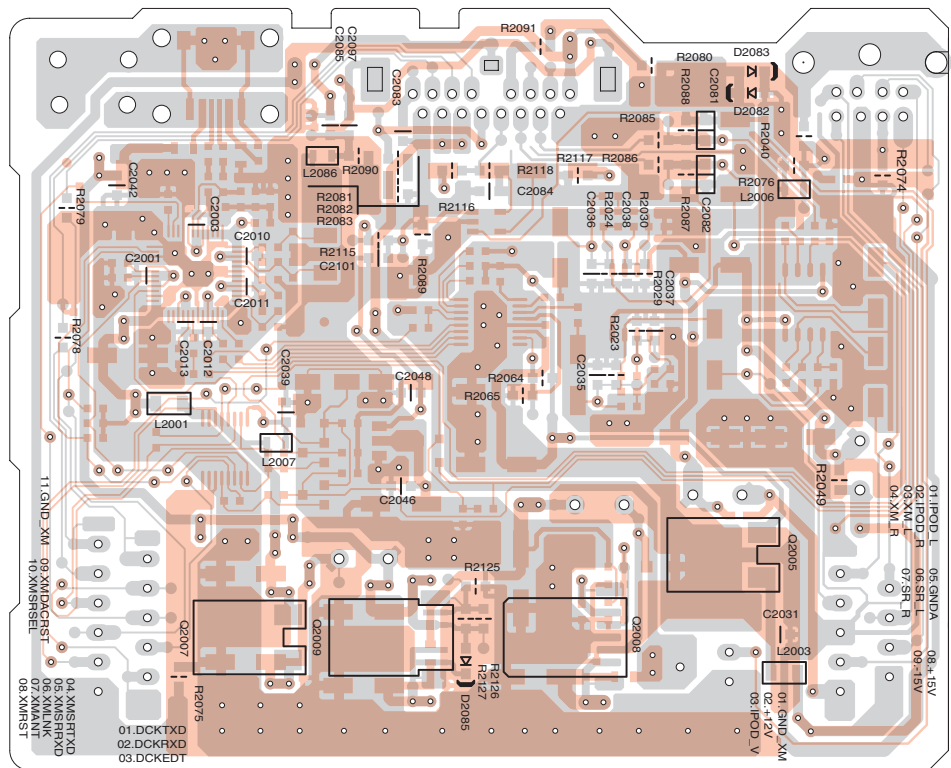

5

A

B

C

D

PRINTED CIRCUIT BOARD VIEWS-9

U36 VIDEO PC BOARD (NAVD-9467)

Component side

1

2

3

4

5

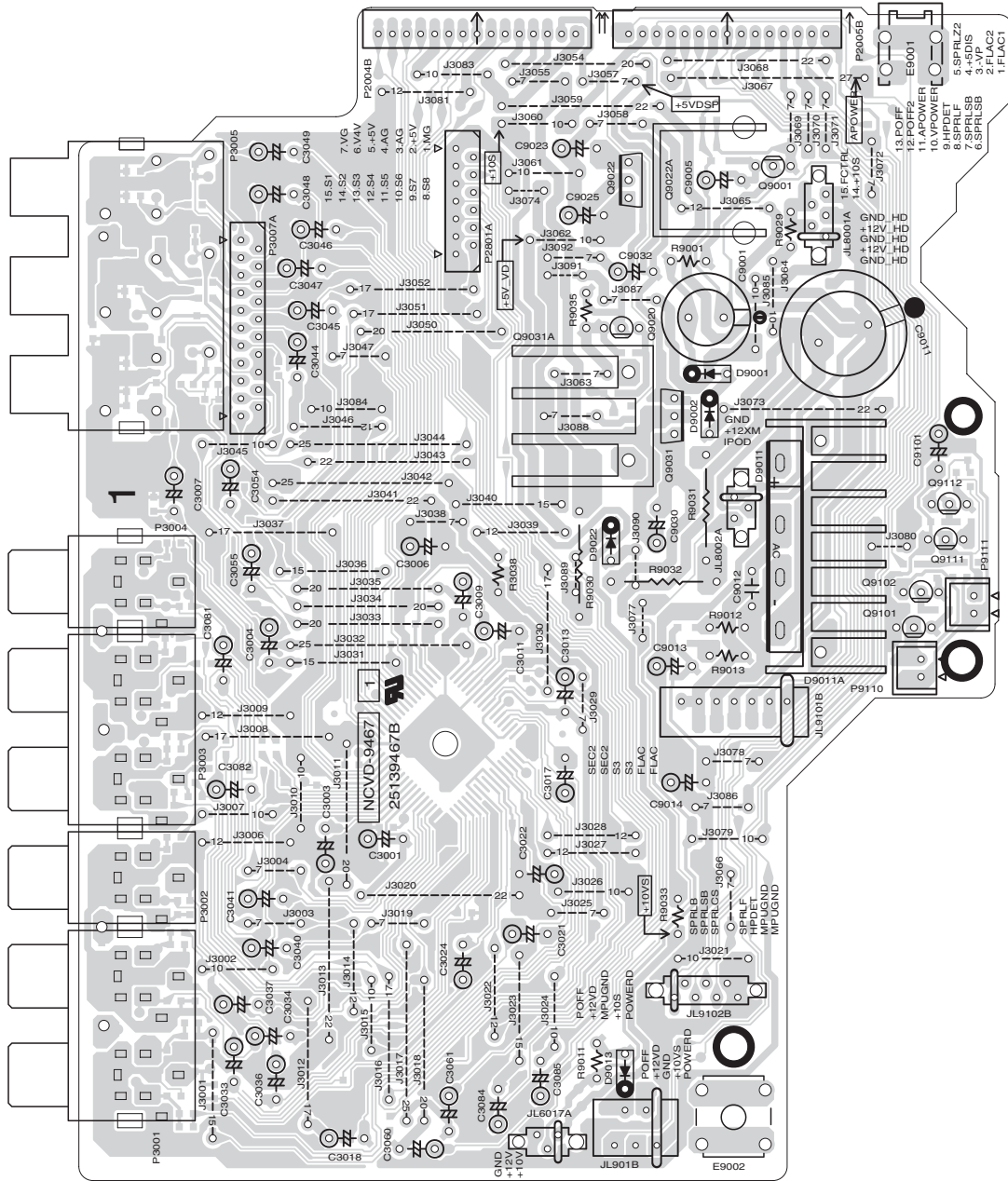

A

B

C

D

PRINTED CIRCUIT BOARD VIEWS-10

U36 VIDEO PC BOARD (NAVD-9467)

Soldering side

1

2

3

4

5

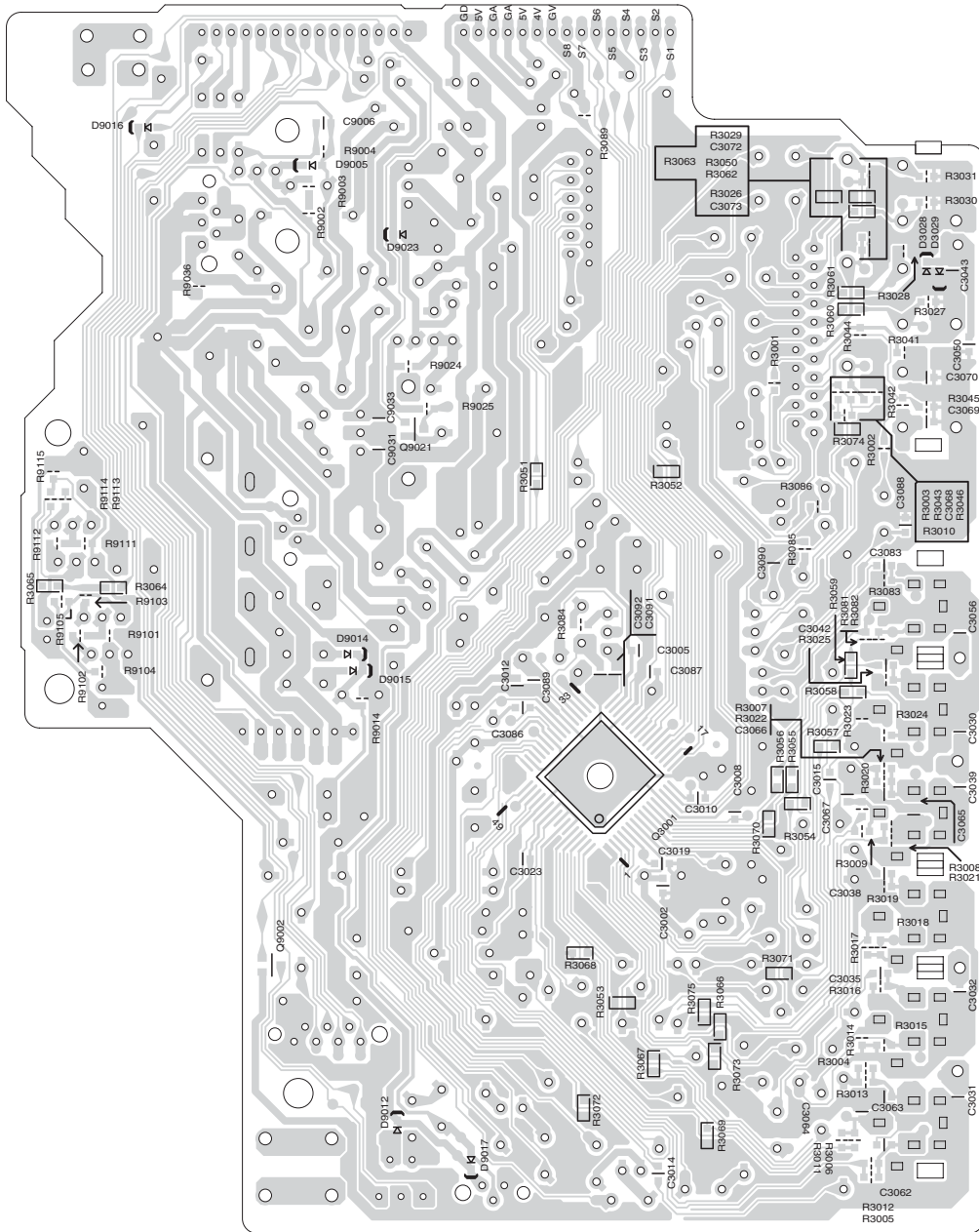

A

B

C

D

PRINTED CIRCUIT BOARD VIEWS-11

U37 SPEAKER TERMINAL PC BOARD (NATRM-9468)

Component side

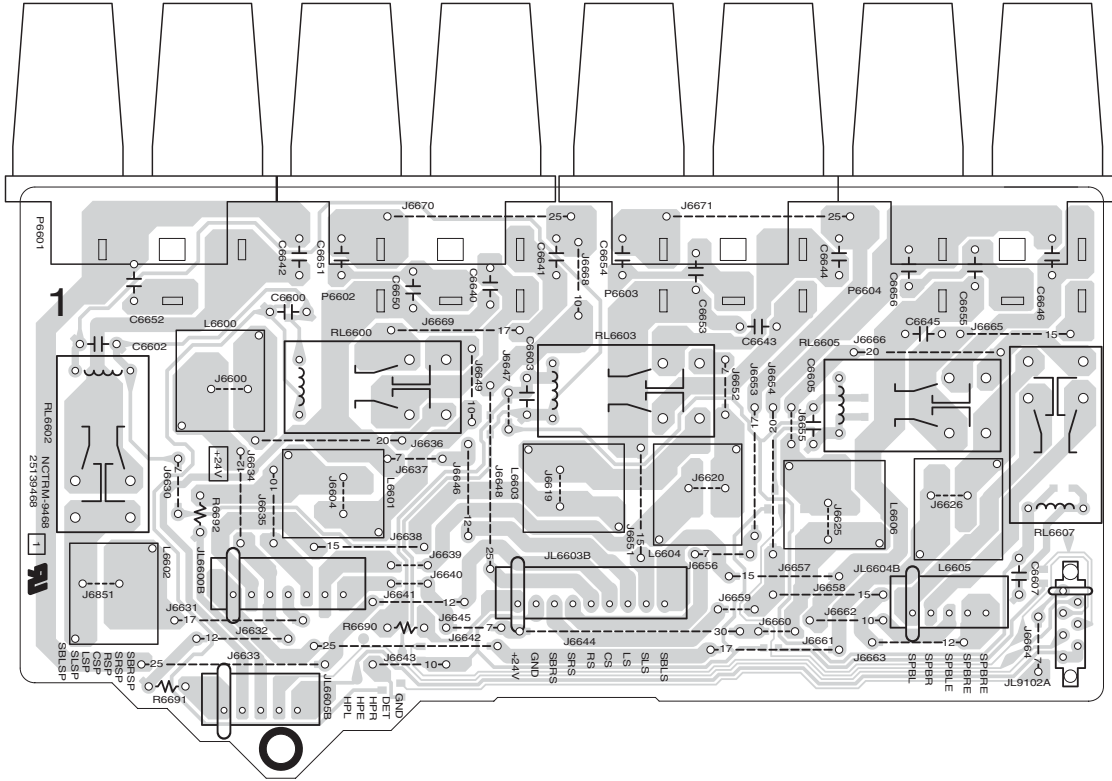

Soldering side

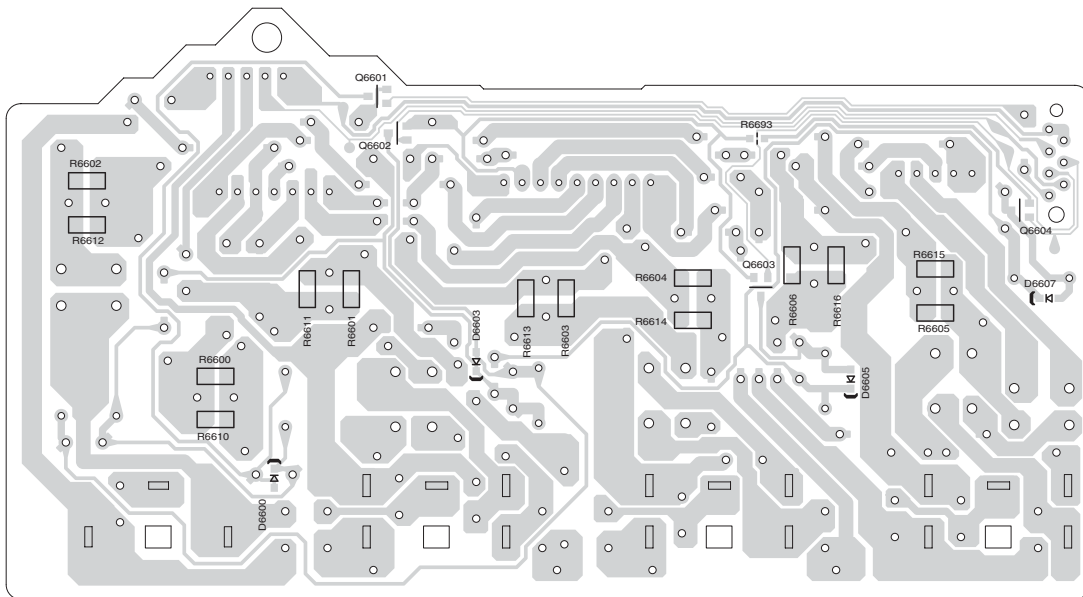

A

B

C

D

PRINTED CIRCUIT BOARD VIEWS-12

**U38 DRIVER AMPLIFIER
PC BOARD
(NACLA-9470)
Component side**

1

2

3

4

5

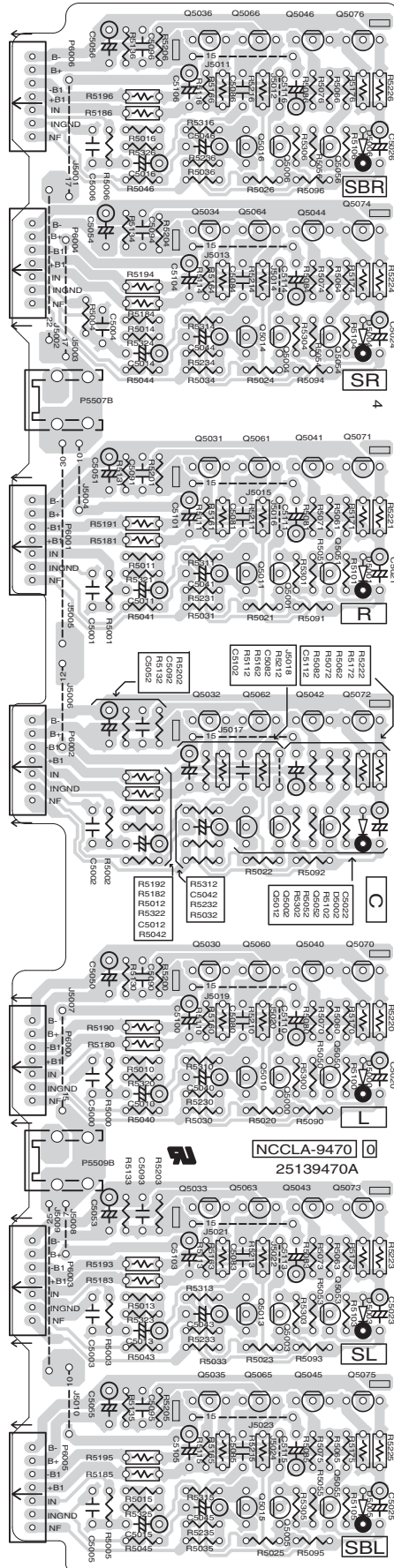

A

B

C

D

PRINTED CIRCUIT BOARD VIEWS-14

U41 HDMI PC BOARD (NAHDM-9473)

Side-B

1

2

3

4

5

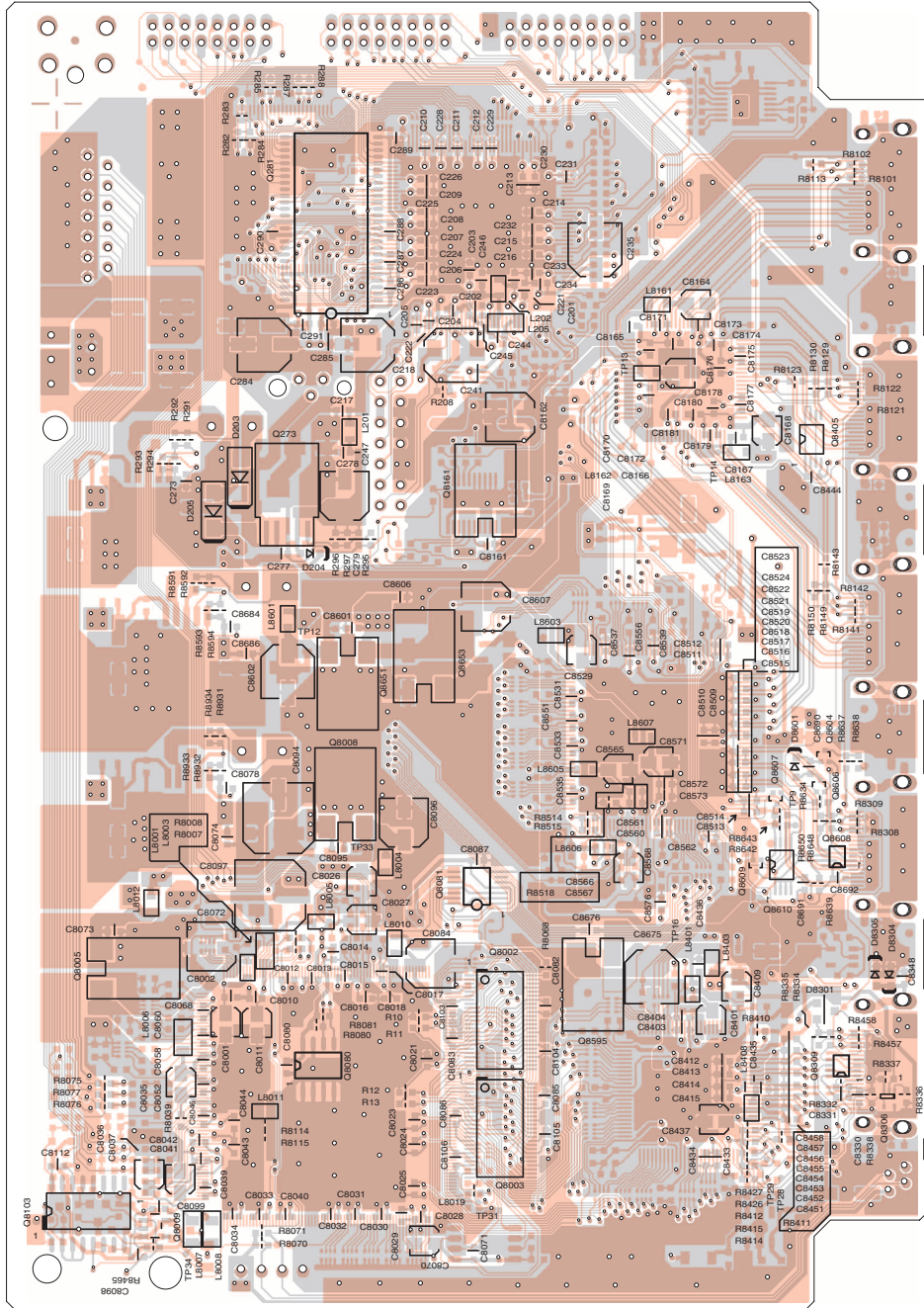

IC BLOCK DIAGRAMS AND TERMINAL DESCRIPTIONS-1

Q201 : D788E001BRFP266 (Floating-Point Digital Signal Processor)-1/5

BLOCK DIAGRAM

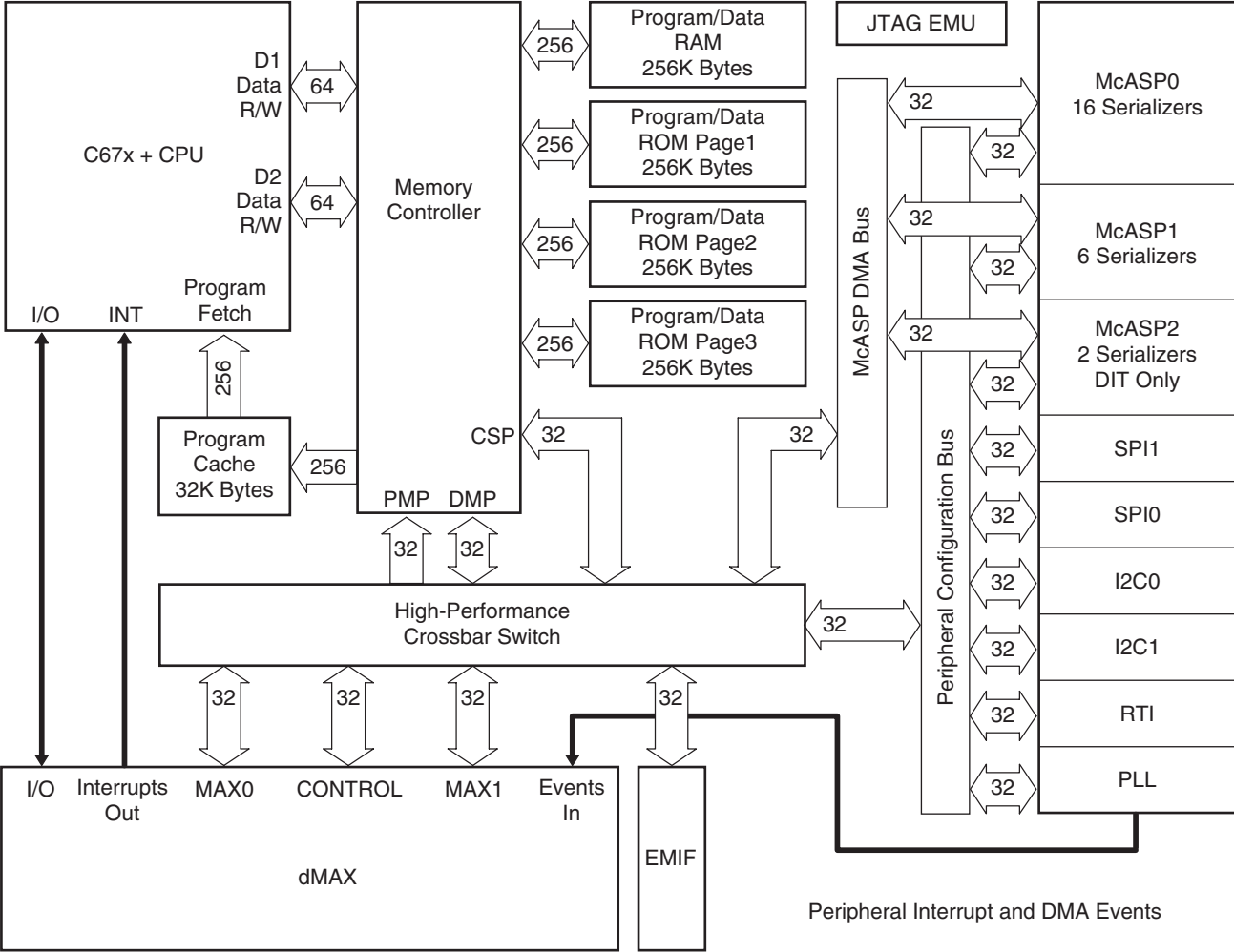

IC BLOCK DIAGRAMS AND TERMINAL DESCRIPTIONS-2

Q201 : D788E001BRFP266 (Floating-Point Digital Signal Processor)-2/5

PIN LAYOUT

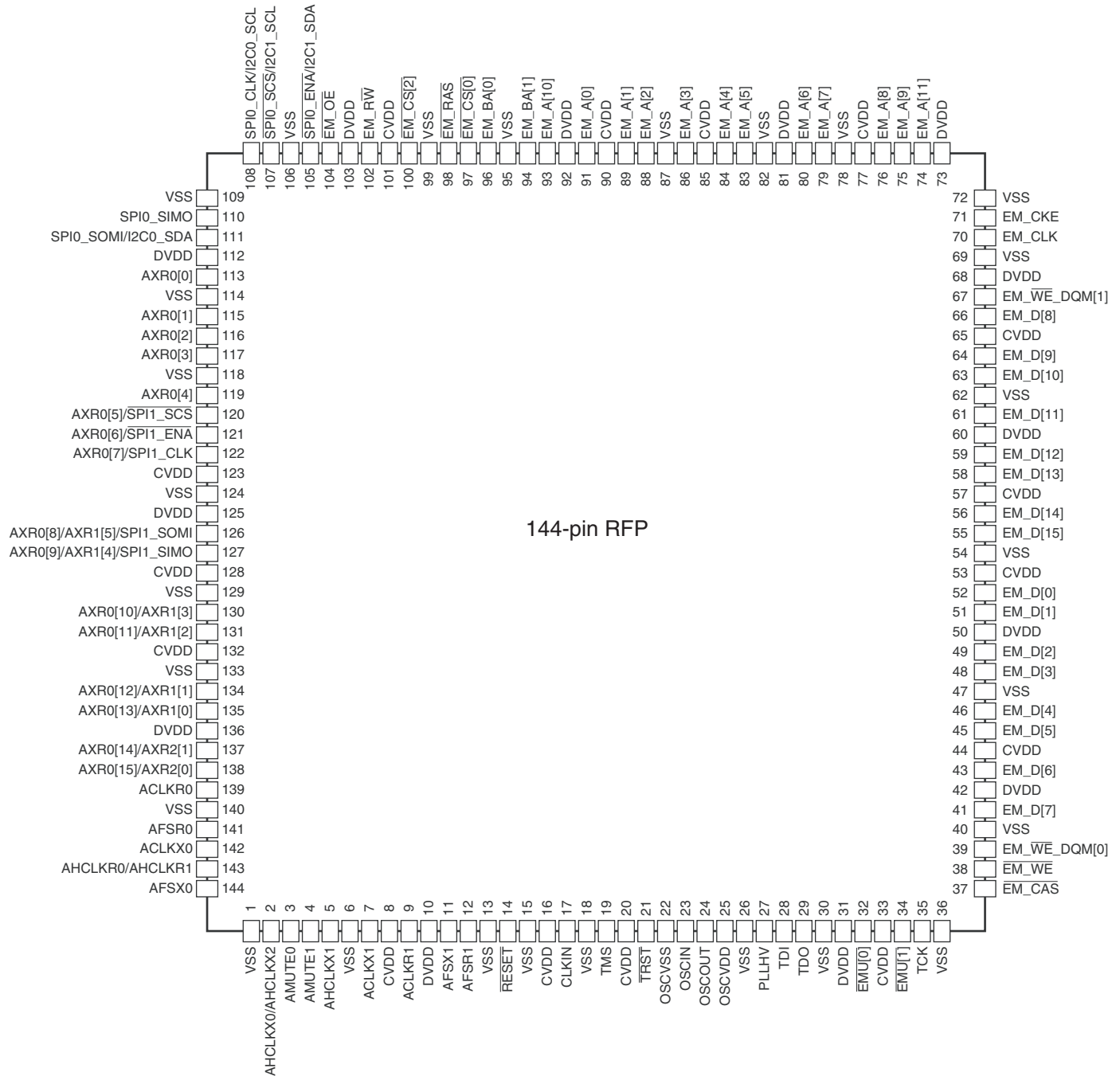

IC BLOCK DIAGRAMS AND TERMINAL DESCRIPTIONS-3

Q201 : D788E001BRFP266 (Floating-Point Digital Signal Processor)-3/5

TERMINAL DESCRIPTION

External Memory Interface (EMIF) Address and Control

Pin Name	Pin No.	Type	Description
EM_A[0]	91	O	EMIF Address Bus
EM_A[1]	89	O	
EM_A[2]	88	O	
EM_A[3]	86	O	
EM_A[4]	84	O	
EM_A[5]	83	O	
EM_A[6]	80	O	
EM_A[7]	79	O	
EM_A[8]	76	O	
EM_A[9]	75	O	
EM_A[10]	93	O	
EM_A[11]	74	O	
EM_BA[0]	96	O	SDRAM Bank Address and Asynchronous Memory Low-Order Address
EM_BA[1]	94	O	
$\bar{E}M_CS[0]$	97	O	SDRAM Chip Select
$\bar{E}M_CS[2]$	100	O	Asynchronous Memory Chip Select
$\bar{E}M_CAS$	37	O	SDRAM Column Address Strobe
$\bar{E}M_RAS$	98	O	SDRAM Row Address Strobe
$\bar{E}M_WE$	38	O	SDRAM Write Enable
EM_CKE	71	O	SDRAM Clock Enable
EM_CLK	70	O	SDRAM Clock
EM_ $\bar{W}E_DQM[0]$	39	O	Write Enable or Byte Enable for EM_D[7:0]
EM_ $\bar{W}E_DQM[1]$	67	O	Write Enable or Byte Enable for EM_D[15:8]
$\bar{E}M_OE$	104	O	SDRAM Output Enable
EM_ $\bar{R}W$	102	O	Asynchronous Memory Read/not Write

External Memory Interface (EMIF) Data Bus

Pin Name	Pin No.	Type	Description
EM_D[0]	52	IO	EMIF Data Bus [Lower 16 Bits]
EM_D[1]	51	IO	
EM_D[2]	49	IO	
EM_D[3]	48	IO	
EM_D[4]	46	IO	
EM_D[5]	45	IO	
EM_D[6]	43	IO	
EM_D[7]	41	IO	
EM_D[8]	66	IO	
EM_D[9]	64	IO	
EM_D[10]	63	IO	
EM_D[11]	61	IO	
EM_D[12]	59	IO	
EM_D[13]	58	IO	
EM_D[14]	56	IO	
EM_D[15]	55	IO	

IC BLOCK DIAGRAMS AND TERMINAL DESCRIPTIONS-4

Q201 : D788E001BRFP266 (Floating-Point Digital Signal Processor)-4/5

TERMINAL DESCRIPTION

McASP0, McASP1, McASP2, and SPI1 Serial Ports

Pin Name	Pin No.	Type	Description
AHCLKR0/AHCLKR1	143	IO	McASP0 and McASP1 Receive Master Clock
ACLKR0	139	IO	McASP0 Receive Bit Clock
AFSR0	141	IO	McASP0 Receive Frame Sync (L/R Clock)
AHCLKX0/AHCLKX2	2	IO	McASP0 and McASP2 Transmit Master Clock
ACLKX0	142	IO	McASP0 Transmit Bit Clock
AFSX0	144	IO	McASP0 Transmit Frame Sync (L/R Clock)
AMUTE0	3	O	McASP0 MUTE Output
AXR0[0]	113	IO	McASP0 Serial Data 0
AXR0[1]	115	IO	McASP0 Serial Data 1
AXR0[2]	116	IO	McASP0 Serial Data 2
AXR0[3]	117	IO	McASP0 Serial Data 3
AXR0[4]	119	IO	McASP0 Serial Data 4
AXR0[5]/SPI1_SC \bar{S}	120	IO	McASP0 Serial Data 5 or SPI1 Slave Chip Select
AXR0[6]/SPI1_EN \bar{A}	121	IO	McASP0 Serial Data 6 or SPI1 Enable (Ready)
AXR0[7]/SPI1_CLK	122	IO	McASP0 Serial Data 7 or SPI1 Serial Clock
AXR0[8]/AXR1[5]/SPI1_SOMI	126	IO	McASP0 Serial Data 8 or McASP1 Serial Data 5 or SPI1 Data Pin Slave Out Master In
AXR0[9]/AXR1[4]/SPI1_SIMO	127	IO	McASP0 Serial Data 9 or McASP1 Serial Data 4 or SPI1 Data Pin Slave In Master Out
AXR0[10]/AXR1[3]	130	IO	McASP0 Serial Data 10 or McASP1 Serial Data 3
AXR0[11]/AXR1[2]	131	IO	McASP0 Serial Data 11 or McASP1 Serial Data 2
AXR0[12]/AXR1[1]	134	IO	McASP0 Serial Data 12 or McASP1 Serial Data 1
AXR0[13]/AXR1[0]	135	IO	McASP0 Serial Data 13 or McASP1 Serial Data 0
AXR0[14]/AXR2[1]	137	IO	McASP0 Serial Data 14 or McASP2 Serial Data 1
AXR0[15]/AXR2[0]	138	IO	McASP0 Serial Data 15 or McASP2 Serial Data 0
ACLKR1	9	IO	McASP1 Receive Bit Clock
AFSR1	12	IO	McASP1 Receive Frame Sync (L/R Clock)
AHCLKX1	5	IO	McASP1 Transmit Master Clock
ACLKX1	7	IO	McASP1 Transmit Bit Clock
AFSX1	11	IO	McASP1 Transmit Frame Sync (L/R Clock)
AMUTE1	4	O	McASP1 MUTE Output

SPI0, I2C0, and I2C1 Serial Port Pins

Pin Name	Pin No.	Type	Description
SPI0_SOMI/I2C0_SDA	111	IO	SPI0 Data Pin Slave Out Master In or I2C0 Serial Data
SPI0_SIMO	110	IO	SPI0 Data Pin Slave In Master Out
SPI0_CLK/I2C0_SCL	108	IO	SPI0 Serial Clock or I2C0 Serial Clock
SPI0_SC \bar{S} /I2C1_SCL	107	IO	SPI0 Slave Chip Select or I2C1 Serial Clock
SPI0_EN \bar{A} /I2C1_SDA	105	IO	SPI0 Enable (Ready) or I2C1 Serial Data

IC BLOCK DIAGRAMS AND TERMINAL DESCRIPTIONS-5

Q201 : D788E001BRFP266 (Floating-Point Digital Signal Processor)-5/5

TERMINAL DESCRIPTION

Clocks

Pin Name	Pin No.	Type	Description
OSCIN	23	I	1.2-V Oscillator Input
OSCOU	24	O	1.2-V Oscillator Output
OSCVDD	25	---	Oscillator 1.2-V VDD tap point (for filter only)
OSCVSS	22	---	Oscillator VSS tap point (for filter only)
CLKIN	17	I	Alternate clock input (3.3-V LVCMOS Input)
PLLHV	27	---	PLL 3.3-V Supply Input (requires external filter)

Device Reset

Pin Name	Pin No.	Type	Description
$\overline{\text{RESET}}$	14	I	Device reset pin

Emulation/JTAG Port

Pin Name	Pin No.	Type	Description
TCK	35	I	Test Clock
TMS	19	I	Test Mode Select
TDI	28	I	Test Data In
TDO	29	O	Test Data Out
$\overline{\text{TRST}}$	21	I	Test Reset
$\overline{\text{EMU}}[0]$	32	IO	Emulation Pin 0
$\overline{\text{EMU}}[1]$	34	IO	Emulation Pin 1

Power Pins

Pin Name	Pin No.
Core Supply (CVDD)	8, 16, 20, 33, 44, 53, 57, 65, 77, 85, 90, 101, 123, 128, 132
IO Supply (DVDD)	10, 31, 42, 50, 60, 68, 73, 81, 92, 103, 112, 125, 136
Ground (VSS)	1, 6, 13, 15, 18, 26, 30, 36, 40, 47, 54, 62, 69, 72, 78, 82, 87, 95, 99, 106, 109, 114, 118, 124, 129, 133, 140

IC BLOCK DIAGRAMS AND TERMINAL DESCRIPTIONS-6

Q281 : M12L64164A-7TG (1M x 16 Bit x 4 Banks Synchronous DRAM)

BLOCK DIAGRAM

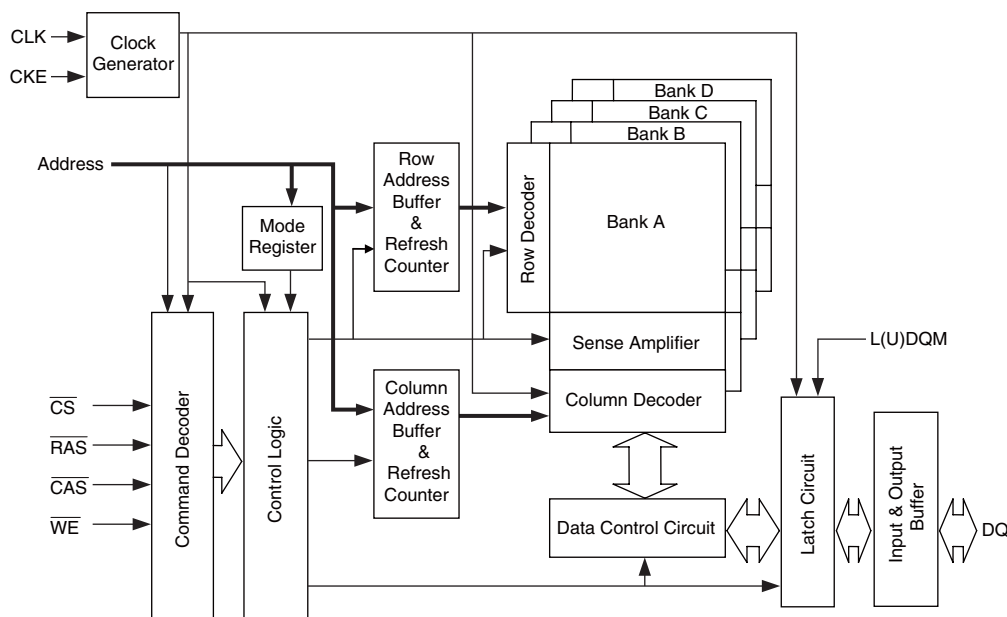

PIN LAYOUT

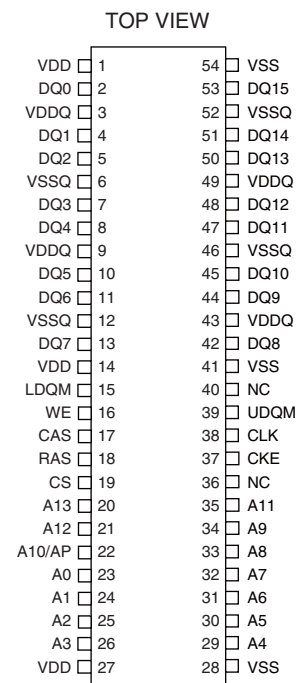

TERMINAL DESCRIPTION

Pin Name	Description
CLK	Active on the positive going edge to sample all inputs.
\overline{CS}	Disables or enables device operation by masking or enabling all inputs except CLK , CKE and L(U)DQM.
CKE	Masks system clock to freeze operation from the next clock cycle. CKE should be enabled at least one cycle prior new command. Disable input buffers for power down in standby.
A0 ~ A11	Row / column address are multiplexed on the same pins. Row address : RA0~RA11, column address : CA0~CA7.
A12 , A13	Selects bank to be activated during row address latch time. Selects bank for read / write during column address latch time.
\overline{RAS}	Latches row addresses on the positive going edge of the CLK with \overline{RAS} low. Enables row access & precharge.
\overline{CAS}	Latches column address on the positive going edge of the CLK with CAS low. Enables column access.
\overline{WE}	Enables write operation and row precharge. Latches data in starting from \overline{CAS} , \overline{WE} active.
L(U)DQM	Makes data output Hi-Z, tSHZ after the clock and masks the output. Blocks data input when L(U)DQM active.
DQ0 ~ DQ15	Data inputs / outputs are multiplexed on the same pins.
VDD / VSS	Power and ground for the input buffers and the core logic.
VDDQ / VSSQ	Isolated power supply and ground for the output buffers to provide improved noise immunity.
NC	This pin is recommended to be left No Connection on the device.

IC BLOCK DIAGRAMS AND TERMINAL DESCRIPTIONS-7

Q282 : ES29LV160ET-70TG (16Mbit CMOS 3.0 Volt-only, Boot Sector Flash Memory)

BLOCK DIAGRAM

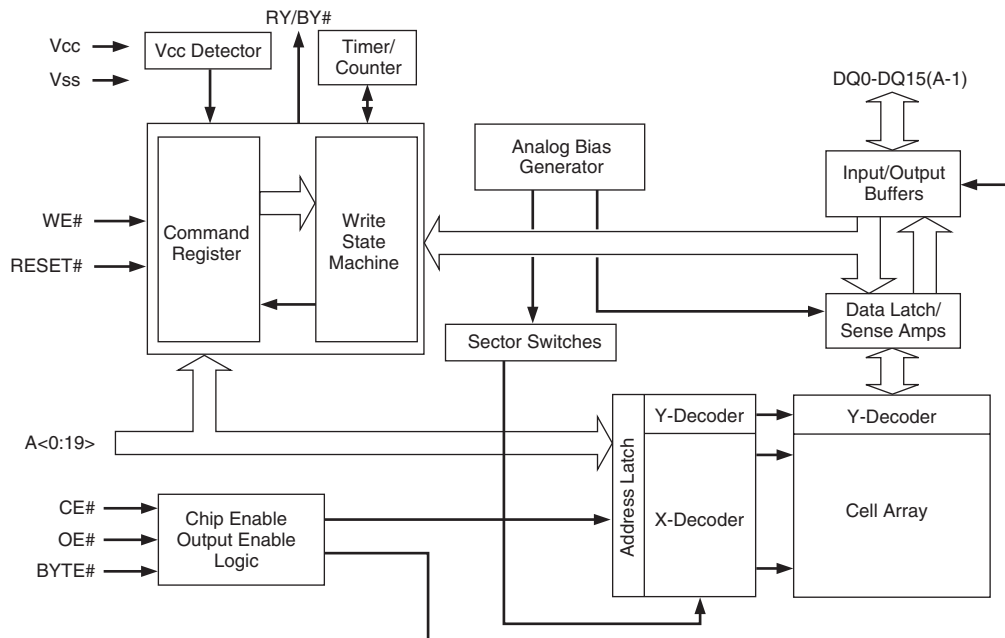

PIN LAYOUT



TERMINAL DESCRIPTION

Pin Name	Description
A0-A19	20 Addresses
DQ0-DQ14	15 Data Inputs/Outputs
DQ15/A-1	DQ15 (Data Input/Output, Word Mode) / A-1 (LSB Address Input, Byte Mode)
CE#	Chip Enable
OE#	Output Enable
WE#	Write Enable
RESET#	Hardware Reset Pin, Active Low
BYTE#	Selects 8-bit or 16-bit mode
RY/BY#	Ready/Busy Output (N/A SO 044)
Vcc	3.0 volt-only single power supply
Vss	Device Ground
NC	Pin Not Connected Internally

IC BLOCK DIAGRAMS AND TERMINAL DESCRIPTIONS-8

Q301 : CS42518 (8-Ch Codec with S/PDIF Receiver)-1/4

BLOCK DIAGRAM

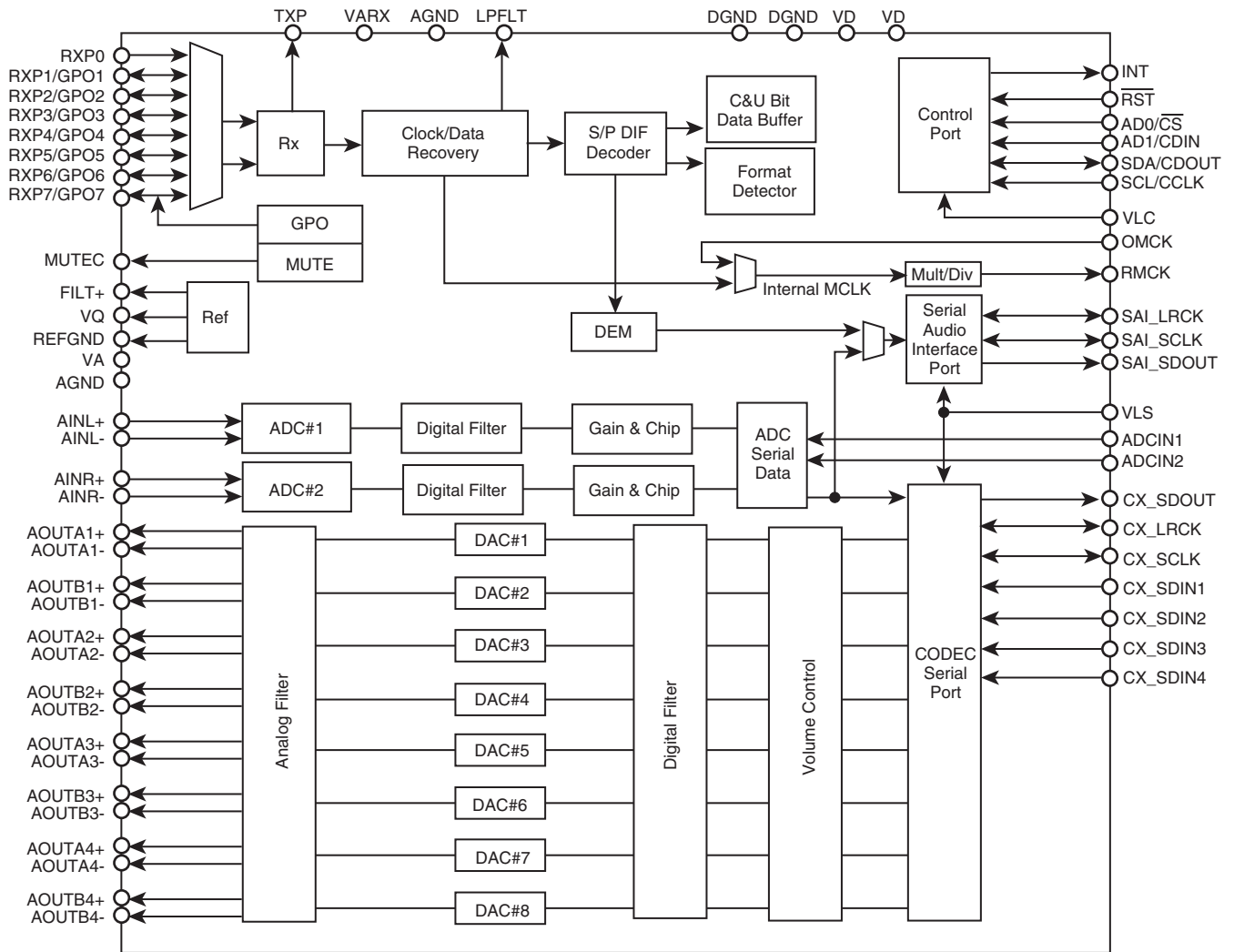

IC BLOCK DIAGRAMS AND TERMINAL DESCRIPTIONS-9

Q301 : CS42518 (8-Ch Codec with S/PDIF Receiver)-2/4

PIN LAYOUT

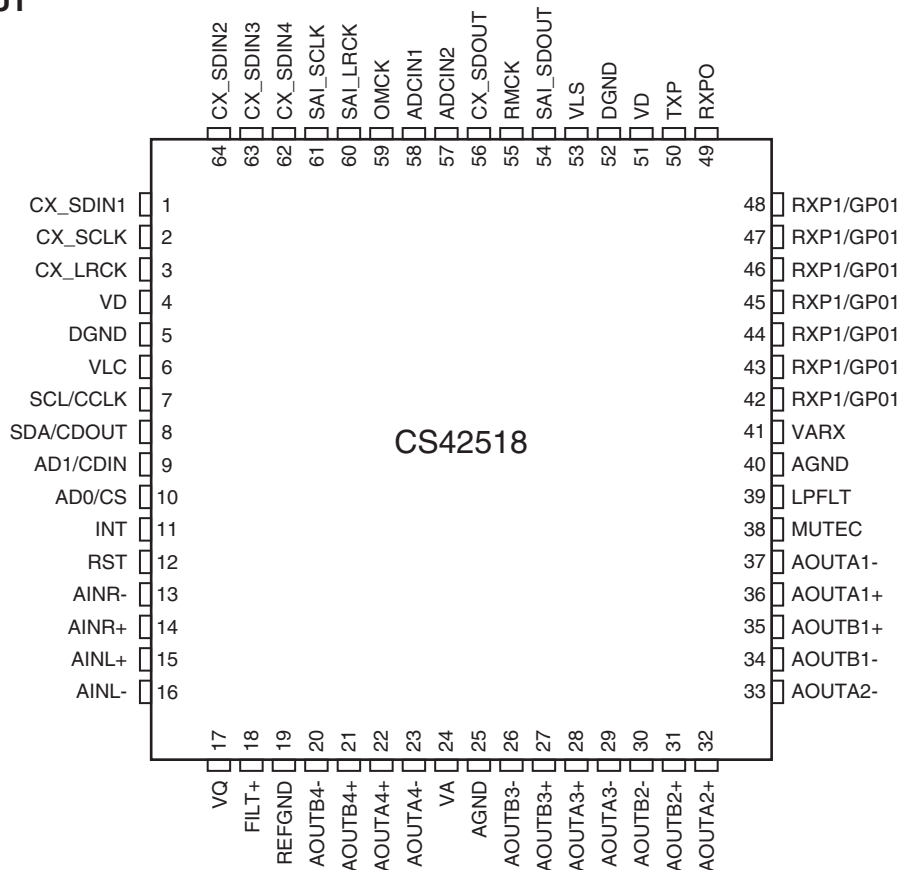

TERMINAL DESCRIPTION

Name	Pin No.	Function
CX_SDIN1 CX_SDIN2 CX_SDIN3 CX_SDIN4	1 64 63 62	Codec Serial Audio Data Input (Input) - Input for two's complement serial audio data.
CX_SCLK	2	CODEC Serial Clock (Input/Output) - Serial clock for the CODEC serial audio interface.
CX_LRCK	3	CODEC Left Right Clock (Input/ Output) - Determines which channel, Left or Right, is currently active on the CODEC serial audio data line.
VD	4 51	Digital Power (Input) - Positive power supply for the digital section.
DGND	5 52	Digital Ground (Input) - Ground reference. Should be connected to digital ground.
VLC	6	Control Port Power (Input) - Determines the required signal level for the control port.
SCL/CCLK	7	Serial Control Port Clock (Input) - Serial clock for the serial control port. Requires an external pull-up resistor to the logic interface voltage in I2C mode as shown in the Typical Connection Diagram.
SDA/CDOOUT	8	Serial Control Data (Input/Output) - SDA is a data I/O line in IC mode and requires an external pull-up resistor to the logic interface voltage, as shown in the Typical connection Diagram. CDOOUT is the output data line for the control port interface in SPI mode.
AD1/CDIN	9	Address Bit 1 (I2C)/Serial Control Data (SPI) (Input) - AD1 a chip address pin in I2C mode; CDIN is the input data line for control port interface in SPI mode.

IC BLOCK DIAGRAMS AND TERMINAL DESCRIPTIONS-10

Q301 : CS42518 (8-Ch Codec with S/PDIF Receiver)-3/4

TERMINAL DESCRIPTION

Name	Pin No.	Function
AD0/CS	10	Address Bit 0 (I2C)/Control Port Chip Select (SPI) (INput) - AD0 is a chip address pin in I2C mode; CS is the chip select signal in SPI mode.
INT	11	Interrupt (Ooutput) - The CS42518 will generate an interrupt condition as per the Interrupt Mask register.
RST	12	Reset (Input) - The device enters a low power mode and all internal registers are reset to their default settings when low.
AINR- AINR+	13 14	Differential right Channel Analog Input (Input) - Signals are presented differentially to the delta-sigma modulators via the AINR+/- pins.
AINL- AINL+	15 16	Differential right Channel Analog Input (Input) - Signals are presented differentially to the delta-sigma modulators via the AINR+/- pins.
VQ	17	Quiescent Voltage (Output) - Filter connection for internal quiescent reference voltage.
FILT+	18	Positive Voltage Reference (Output) - Positive reference voltage for the internal sampling circuits.
REFGND	19	Reference Ground (Input) - Ground reference for the internal sampling circuits.
AOUTA1 +, - AOUTB1 +, - AOUTA2 +, - AOUTB2 +, - AOUTA3 +, - AOUTB3 +, - AOUTA4 +, - AOUTB4 +, -	36, 37 35, 34 32, 33 31, 30 28, 29 27, 26 22, 23 21, 20	Differential Analog Output (Output) - The full-scale differential analog output level is specified in the Analog Characteristics specification table.
VA VARX	24 41	Analog Power (Input) - Positive power supply for the analog section.
AGND	25 40	Analog Ground (Input) - Ground reference. Should be connected to analog ground.
MUTECL	38	Mute Control (Output) - The Mute Control pin outputs high impedance following an initial power -on condition or whenever the PDN bit is set to a "1", forcing the codec into power -down mode. The signal will remain in a high impedance state as long as the part is in power-down mode. The Mute Control pin goes to the selected "active" state during reset, muting, or if the master clock to left/right clock frequency ratio is incorrect. This pin is intended to be used as a control for external mute circuits to prevent the clicks and pops that can occur in any single supply system. The use of external mute circuits are not mandatory but may be desired for designs requiring the absolute minimum in extraneous clicks and pops.
LPFLT	39	PLL Loop Filter (Output) - An RC network should be connected between this pin and ground.
RXP7/GPO7 RXP6/GPO6 RXP5/GPO5 RXP4/GPO4 RXP3/GPO3 RXP2/GPO2 RXP1/GPO1	42 43 44 45 46 47 48	S/PDIF Receiver Input/ General Purpose Output (Input/ Output) - Receiver inputs for S/PDIF encoded data. The CS42518 has an internal 8:2 multiplexer to select the active receiver port, according to the Receiver Mode Control 2 register. These pins can also be configured as general purpose output pins, ADC Overflow indicators or Mute Control outputs according to the RXP/General Purpose Pin Control registers.
RXP0	49	S/PDIF Receiver Input (Input) - Dedicated receiver input for S/PDIF encoded data.
TXP	50	S/PDIF Transmitter Output (Output) - S/PDIF encoded data output, mapped directly from one of the receiver inputs as indicated by the Receiver Mode Control 2 register.
VLP	53	Serial Port Interface Power (Input) - Determines the required signal level for the serial port interfaces.
SAI_SDOOUT	54	Serial Audio Interface Serial Data Output (Output) - Output for two's complement serial audio PCM data from the S/PDIF incoming stream. This pin can also be configured to transmit the output of the internal and external ADCs.
RMCK	55	Recovered Master Clock (Output) - Recovered master clock output from the External Clock Reference

IC BLOCK DIAGRAMS AND TERMINAL DESCRIPTIONS-11**Q301 : CS42518 (8-Ch Codec with S/PDIF Receiver)-4/4****TERMINAL DESCRIPTION**

Name	Pin No.	Function
CL_SDOOUT	56	CODEC Serial Data Output (Output) - Output for two's complement serial audio data the internal and external ADCs.
ADCIN1 ADCIN2	58 57	External ADC Serial Input (Input) - The CS42518 provides for up two external stereo analog to digital converter inputs to provide a maximum of six channels on serial data output line when the CS42518 is placed in One Line mode.
OMCK	59	External Reference Clock (Input) - External clock reference that must be within the ranges specified in currently active on the serial audio data line.
SAI_LRCK	60	Serial Audio Interface Left/Right Clock (Input/Output) - Determines which channel, Left of Right, is currently active on the serial audio data line.
SAI_LRCK	61	Serial Audio Interface Serial Clock (Input/Output) - Serial clock for the Serial Audio Interface.

IC BLOCK DIAGRAMS AND TERMINAL DESCRIPTIONS-12

Q3001 : AN15880A (Video SW for Receiver with Multi-signal)-1/3

BLOCK DIAGRAM

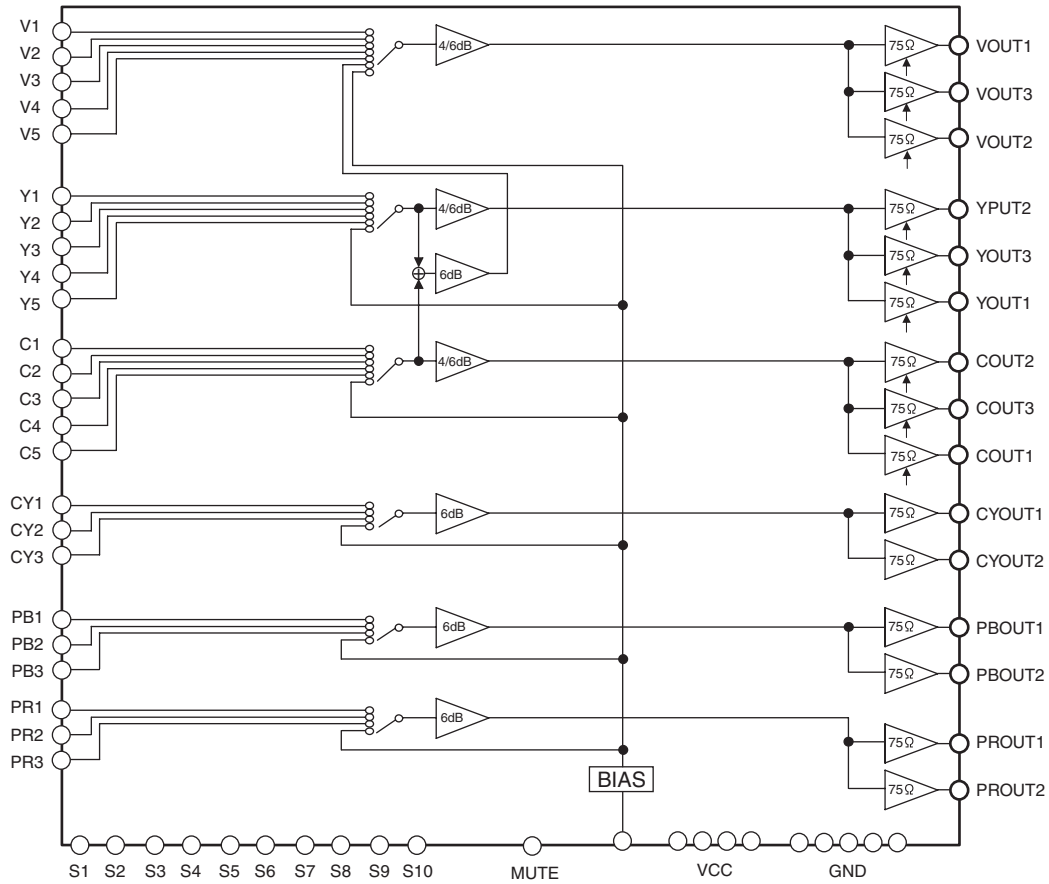

PIN CONFIGURATION

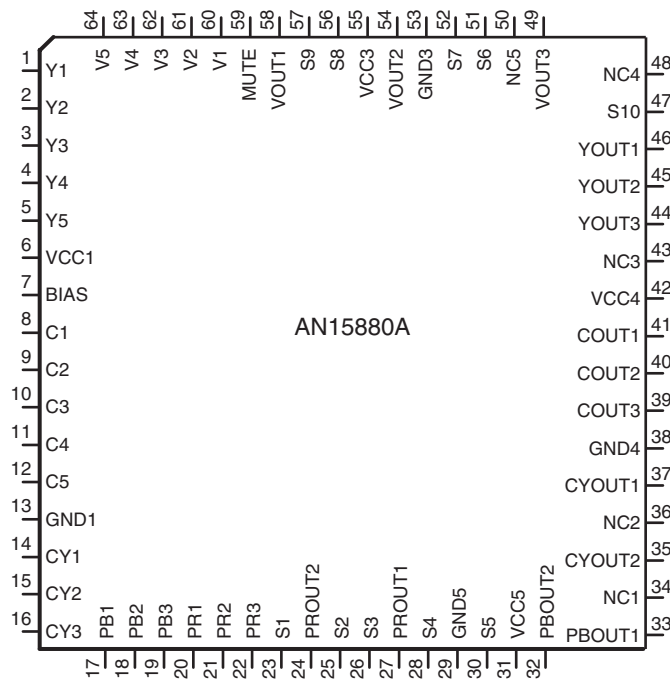

IC BLOCK DIAGRAMS AND TERMINAL DESCRIPTIONS-13

Q3001 : AN15880A (Video SW for Receiver with Multi-signal)-2/3

TERMINAL DESCRIPTION (1/2)

Pin No.	Pin name	Type	Description
1	Y1	Input	Luminance signal input 1
2	Y2	Input	Luminance signal input 2
3	Y3	Input	Luminance signal input 3
4	Y4	Input	Luminance signal input 4
5	Y5	Input	Luminance signal input 5
6	VCC1	Power supply	5.0 V power supply
7	BIAS	Output	Bias voltage
8	C1	Input	Chrominance signal input 1
9	C2	Input	Chrominance signal input 2
10	C3	Input	Chrominance signal input 3
11	C4	Input	Chrominance signal input 4
12	C5	Input	Chrominance signal input 5
13	GND1	Ground1	Ground
14	CY1	Input	CY1 signal input
15	CY2	Input	CY2 signal input
16	CY3	Input	CY3 signal input
17	PB1	Input	PB1 signal input
18	PB2	Input	PB2 signal input
19	PB3	Input	PB3 signal input
20	PR1	Input	PR1 signal input
21	PR2	Input	PR2 signal input
22	PR3	Input	PR3 signal input
23	S1	Input	Logic control input 1
24	PROUT2	Output	PROUT2 signal output
25	S2	Input	Logic control input 2
26	S3	Input	Logic control input 3
27	PROUT1	Output	PROUT1 signal output
28	S4	Input	Logic control input 4
29	GND5	Ground	Ground
30	S5	Input	Logic control input 5
31	VCC5	Power supply	5.0 V power supply
32	PBOUT2	Output	PBOUT2 signal output
33	PBOUT1	---	PBOUT1 signal output
34	NC1	Output	No connection
35	CYOUT2	Output	CYOUT2 signal output

IC BLOCK DIAGRAMS AND TERMINAL DESCRIPTIONS-14

Q3001 : AN15880A(Video SW for Receiver with Multi-signal)-3/3

TERMINAL DESCRIPTION (2/2)

Pin No.	Pin name	Type	Description
36	NC2	---	No connection
37	CYOUT1	Output	CYOUT1 signal output
38	GND4	Ground	Ground
39	COOUT3	Output	COOUT3 signal output
40	COOUT2	Output	COOUT2 signal output
41	COOUT1	Output	COOUT1 signal output
42	VCC4	Power supply	5.0 V power supply
43	NC3	---	No connection
44	YOUT3	Output	YOUT3 signal output
45	YOUT2	Output	YOUT2 signal output
46	YOUT1	Output	YOUT1 signal output
47	S10	Input	Logic control input 10
48	NC4	---	No connection
49	VOOUT3	Output	VOOUT3 signal output
50	NC5	---	No connection
51	S6	Input	Logic control input 6
52	S7	Input	Logic control input 7
53	GND3	Ground	Ground
54	VOOUT2	Output	VOOUT2 signal output
55	VCC3	Power supply	5.0 V power supply
56	S8	Input	Logic control input 8
57	S9	Input	Logic control input 9
58	VOOUT1	Output	VOOUT1 signal output
59	MUTE	Input	Logic mute control input
60	V1	Input	Video composite signal input 1
61	V2	Input	Video composite signal input 2
62	V3	Input	Video composite signal input 3
63	V4	Input	Video composite signal input 4
64	V5	Input	Video composite signal input 5

IC BLOCK DIAGRAMS AND TERMINAL DESCRIPTIONS-15

Q5501 : R2S15211FP (8 ch Electronic Volume and 11 Input Selector and Tone Control)-1/3

SYSTEM BLOCK DIAGRAM

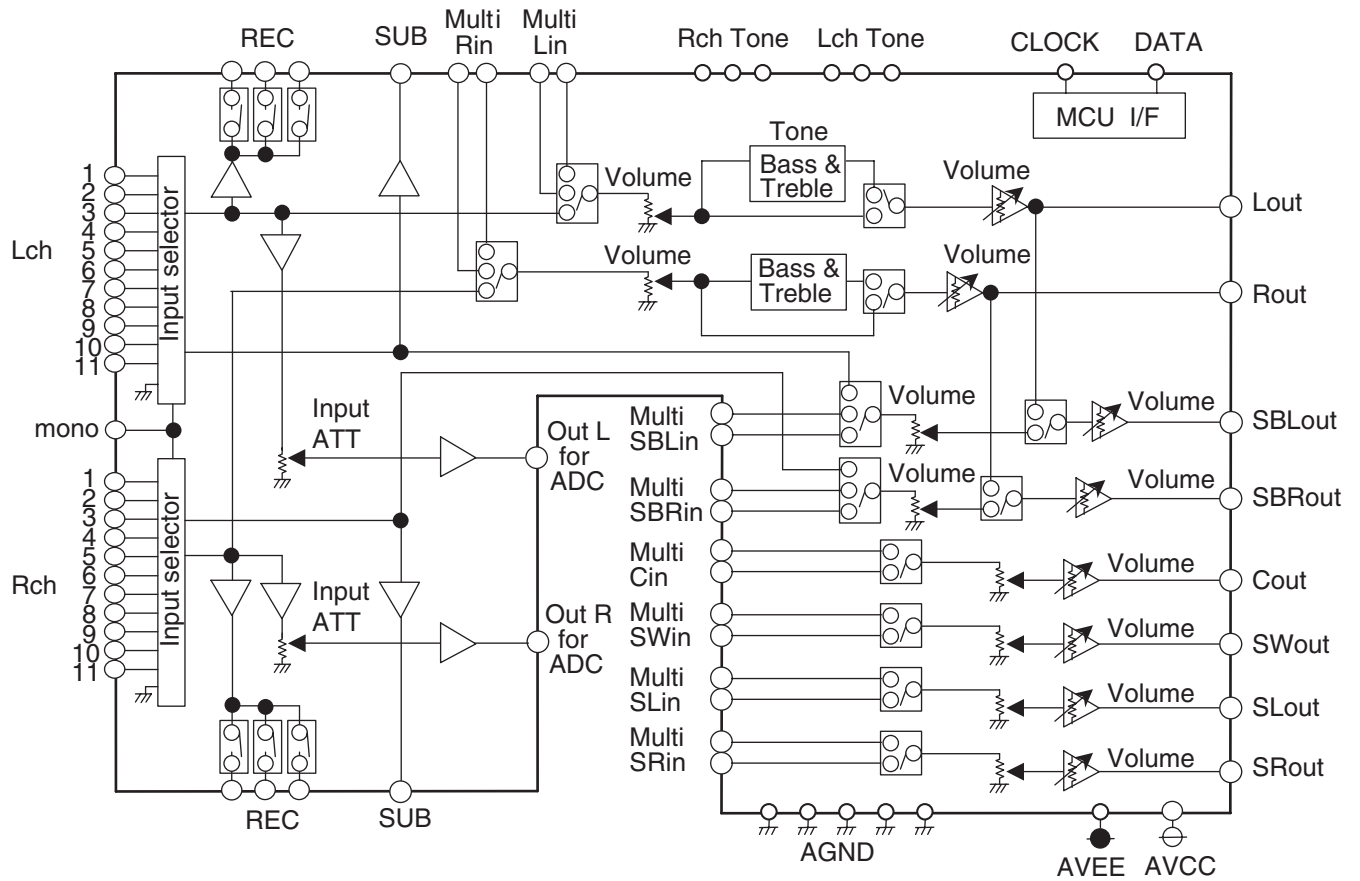

IC BLOCK DIAGRAMS AND TERMINAL DESCRIPTIONS-16

Q5501 : R2S15211FP (8 ch Electronic Volume and 11 Input Selector and Tone Control)-2/3

BLOCK DIAGRAM AND PIN CONFIGURATION

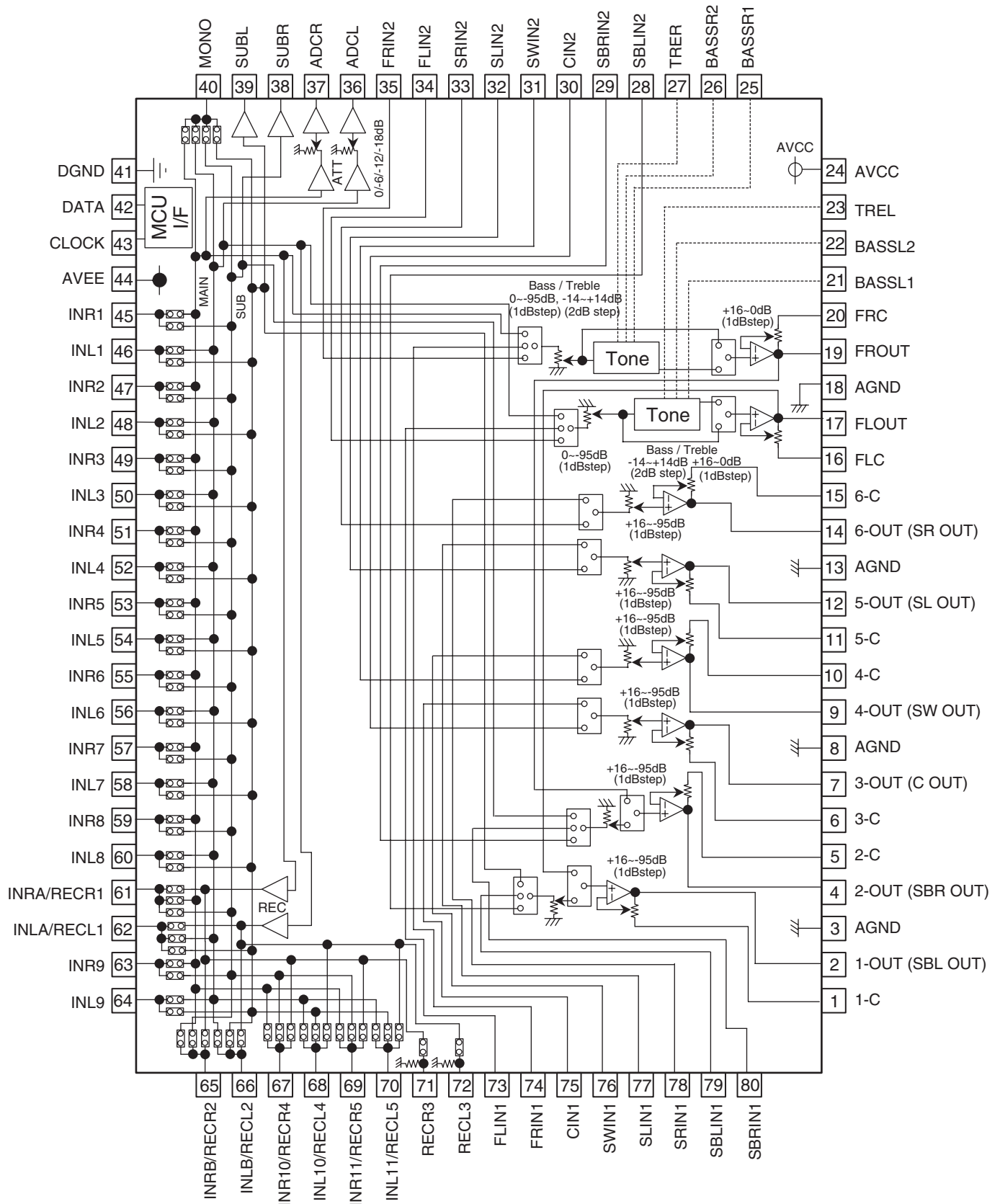

IC BLOCK DIAGRAMS AND TERMINAL DESCRIPTIONS-17

Q5501 : R2S15211FP (8 ch Electronic Volume and 11 Input Selector and Tone Control)-3/3

TERMINAL DESCRIPTION

PIN No.	Name	Function
19,17, 14,12, 9,7, 4,2	FROUT,FLOUT, 6-OUT,5-OUT, 4-OUT, 3-OUT, 2-OUT,1-OUT	Output pin of FL/FR/C/SW/SL/SR/SBL/SBR channel
20,16, 15,11, 10,6, 5,1	FRC,FLC, 6-C,5-C, 4-C,3-C, 2-C,1-C	Connects capacitor for reducing click noise of L/R/C/SW/SL/SR/SBL/SBR channel volume
3,8, 13,18	AGND	Analog ground of internal circuit
23,27	TREL, TRER	Frequency characteristic setting pin of L/R channel tone control(Treble)
21,22, 25,26	BASSL1, BASSL2 BASSR1, BASSR2	Frequency characteristic setting pin of L/R channel tone control(Bass)
24	AVCC	Positive power supply to internal circuit
35,34, 33,32, 31,30, 29,28	FRIN2, FLIN2, SRN2,SLIN2, SWIN2,CIN2, SBRIN2,SBLIN2	Input pin of L/R/C/SW/SL/SR/SBL/SBR channel (Multi IN 1/2)
73,74, 75,76, 77,78, 79,80	FLIN1, FRIN1, CIN1,SWIN1, SLIN1,SRIN1, SBLIN1,SBRIN1	
41	DGND	Digital ground of internal circuit
42	DATA	Input pin of control data
43	CLOCK	Input pin of control clock
44	AVEE	Negative power supply to internal circuit
46,48,50, 52,54,56, 58,60,64	INL1, INL2, INL3, INL4, INL5, INL6, INL7, INL8, INL9	Input pin of L/R channel (Input Selector)
45,47,49, 51,53,55, 57,59,63	INR1, INR2, INR3, INR4, INR5, INR6, INR7, INR8, INR9	
40	MONO	Input pin of monaural (Input Selector)
38,39	SUBL,SUBR	Output pin for L/R channel SUB Output
36,37	ADCL, ADCR	Output pin for L/R channel ADC
72	RECL3	Output pin for L/R channel REC Output
71	RECR3	
61,62, 65,66, 67,68, 69,70	INRA/RECR1,INLA/RECL1, INRB/RECR2,INLB/RECL2, INR10/RECR4,INL10/RECL4, INR11/RECR5,INL11/RECL5	Input pin of L/R channel (Input Selector)/ Output pin for L/R channel REC Output

IC BLOCK DIAGRAMS AND TERMINAL DESCRIPTIONS-18

Q7003 : M66005-0001AHP (FL Tube Driver)

BLOCK DIAGRAM

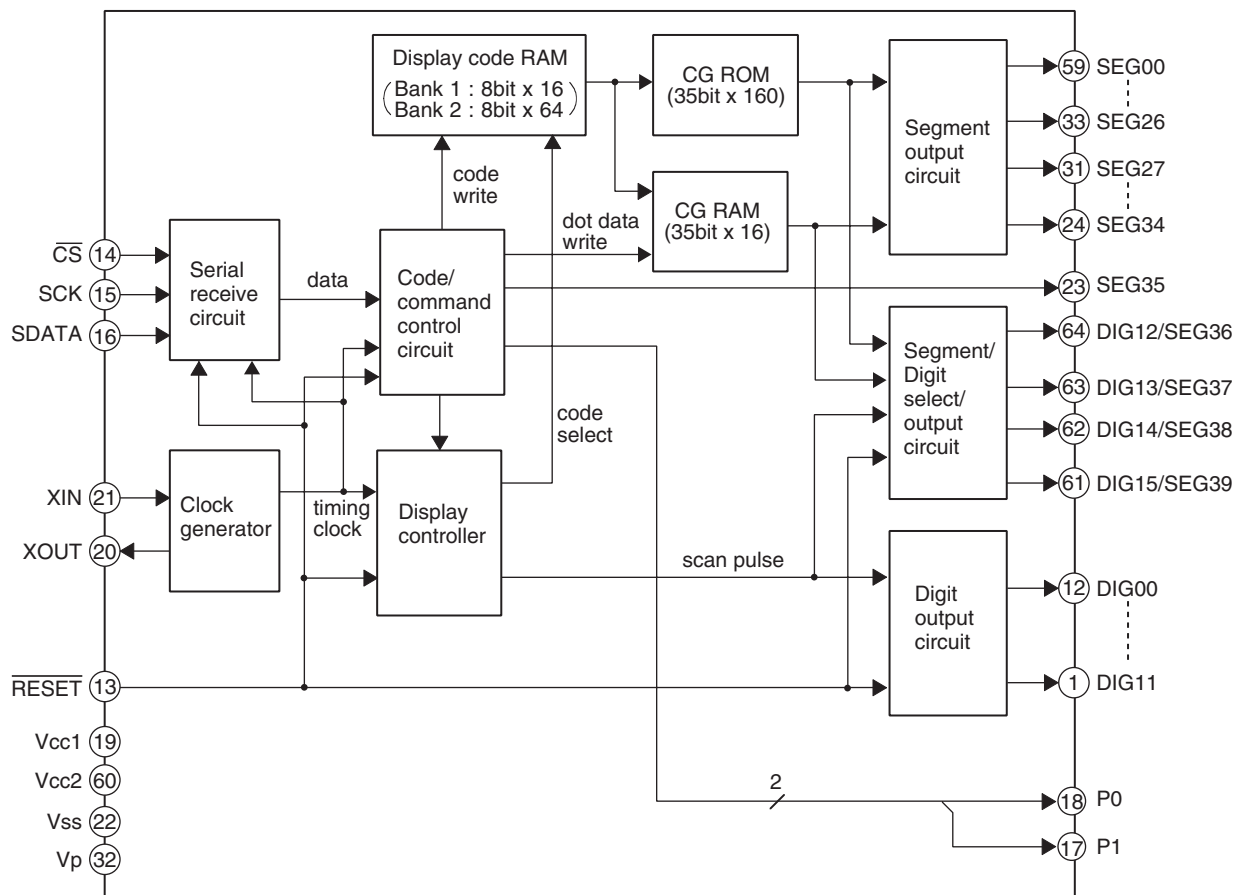

TERMINAL DESCRIPTION

PIN NO.	SYMBOL	PIN NAME	DESCRIPTION
13	$\overline{\text{RESET}}$	Reset input	This pin is used to initialize the internal state of the M66004.
14	$\overline{\text{CS}}$	Chip select input	"L" : Communication with the MCU is possible. "H" : Any instruction from the MCU is neglected.
15	SCK	Shift clock input	At the rising edge from "L" to "H", input data is shifted.
16	SDATA	Serial data input	Character code or command data to display is input from MSB.
21, 20	XIN, XOUT	Clock input Clock output	This pin is used to connect a resistor and a capacitor externally to set oscillation frequency.
1~12 61~64	DIG00 ~ DIG15	Digit output	These pins are used to connect to digit pins of VFD.
23~31 33~59	SEG00 ~ SEG39	Segment output	These pins are used to connect to segment pins of VFD.
17, 18	P0, P1	---	Output port (static operation)
19	VCC1	---	Positive power supply for internal logic.
60	VCC2	---	Positive power supply for high-pressure-resistant output port.
22	VSS	---	GND
32	VP	---	Negative power supply for VFD drive.

IC BLOCK DIAGRAMS AND TERMINAL DESCRIPTIONS-19

Q8001 : FLI30502 (LCD TV Controller with Worldwide Standard Sound Processor and HDMI Receiver)-1/12

BLOCK DIAGRAM

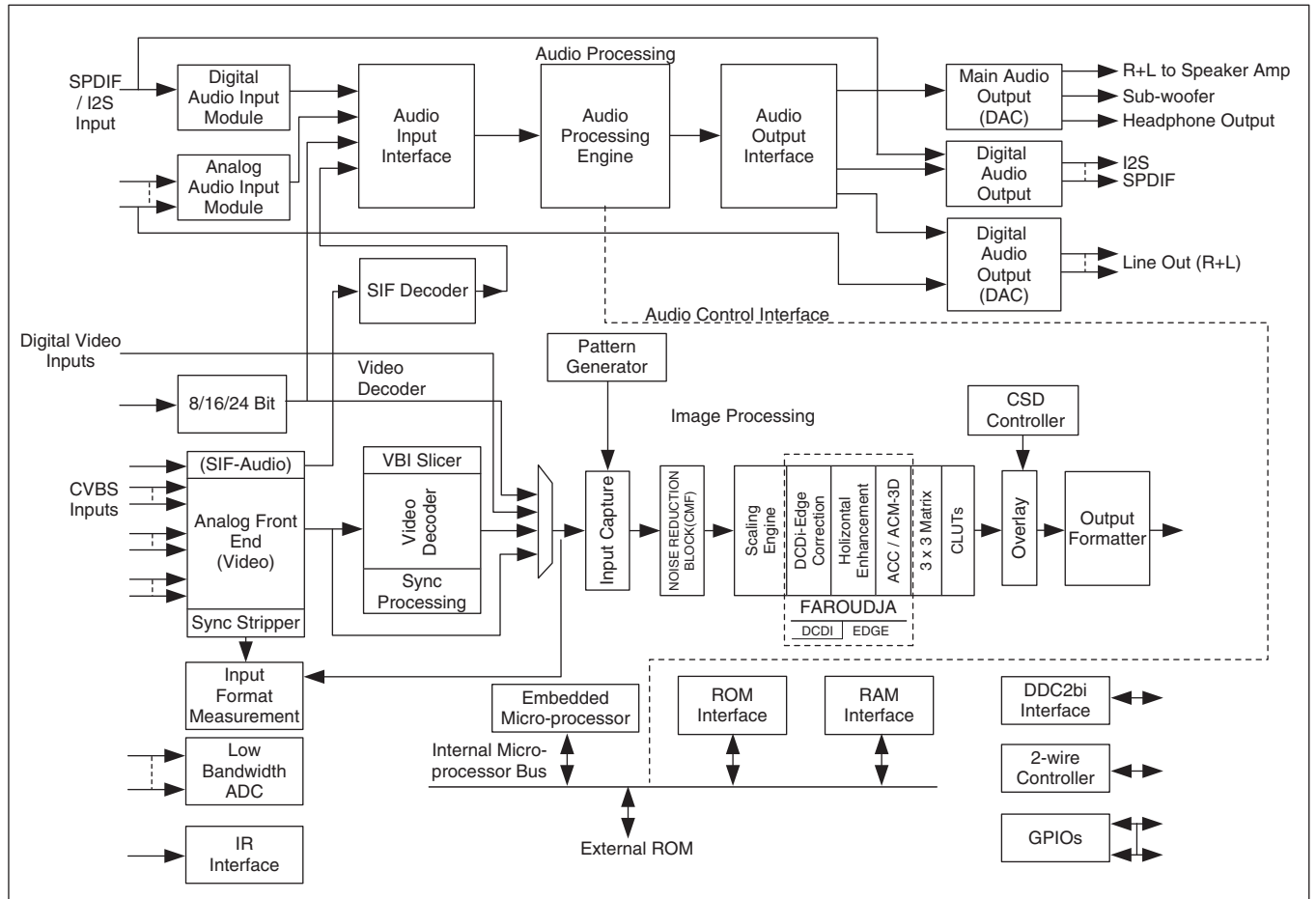

IC BLOCK DIAGRAMS AND TERMINAL DESCRIPTIONS-20

Q8001 : FLI30502 (LCD TV Controller with Worldwide Sandard Sound Processor and HDMI Receiver)-2/12

PIN LAYOUT

VDDA33_LBADC	1	VOUT2	256
LBADC_IN1	2	SVN	255
LBADC_IN2	3	VDDA	254
LBADC_IN3	4	CP1	253
LBADC_IN4	5	CP2	252
VSSA33_LBADC	6	CP3	251
RESETn	7	GNDA	250
VBUFC_RPLL	8	GNDA	249
VDD_RPLL_18	9	GNDA	248
GND_RPLL	10	GNDA	247
XTAL	11	GNDA	246
TCLK	12	GNDA	245
AVDD_RPLL_33	13	GNDA	244
VSYNC1_VGA	14	GNDA	243
HSYNC1_VGA	15	GNDA	242
STL_TM2	16	GNDA	241
GPIO15/STL_TM1/EXT_CSn	17	GNDA	240
SCART16	18	GNDA	239
CVDD_18	19	GNDA	238
CRVSS	20	GNDA	237
HOST_SCLK/UART_DI/JTAG_CLK	21	GNDA	236
HOST_SDATA/UART_DO/JTAG_MODE	22	GNDA	235
DDC_SCLK	23	GNDA	234
DDC_SDATA	24	GNDA	233
CVDD_18	25	GNDA	232
CRVSS	26	GNDA	231
MSTR_SCLK	27	GNDA	230
MSTR_SDATA	28	GNDA	229
RVDD_33	29	GNDA	228
CRVSS	30	GNDA	227
GPIO0	31	GNDA	226
GPIO1	32	GNDA	225
GPIO2	33	GNDA	224
GPIO3	34	GNDA	223
GPIO6/Rin	35	GNDA	222
CVDD_18	36	GNDA	221
CRVSS	37	GNDA	220
GPIO7/IRQin	38	GNDA	219
GPIO8/IRQout	39	GNDA	218
GPIO9/SIPC_SCLK/A19	40	GNDA	217
GPIO10/SIPC_SDSATA/A20	41	GNDA	216
CVDD_18	42	GNDA	215
CRVSS	43	GNDA	214
GPIO11/PWM0	44	GNDA	213
GPIO12/PWM1	45	GNDA	212
RVDD_33	46	GNDA	211
CRVSS	47	GNDA	210
GPIO13/PWM2/JTAG_RESET	48	GNDA	209
GPIO14/PWM3/SCART16_1	49	GNDA	208
CVDD_18	50	GNDA	207
CRVSS	51	GNDA	206
GPIO4/VIDIN_HS	52	GNDA	205
GPIO5/VIDIN_VS	53	GNDA	204
VID2_CLK/ROM_OEn	54	GNDA	203
VID_DE_FLD/A0/GPIO16	55	GNDA	202
I2S_SPDIF_IN_DATA	56	GNDA	201
I2S_IN_WCLK/GPIO50	57	GNDA	200
I2S_IN_BCLK/GPIO51	58	GNDA	199
I2S0_SPDIF_OUT_DATA	59	GNDA	198
I2S_OUT_WCLK/GPIO52	60	GNDA	197
I2S_OUT_BCLK/GPIO53	61	GNDA	196
I2S1_OUT_DATA	62	GNDA	195
AUD_CLKOUT	63	GNDA	194
	64	GNDA	193
CVDD_18	65	GNDA	192
CRVSS	66	GNDA	191
DEN/VOP_FLD	67	GNDA	190
DHSVOP_HS	68	GNDA	189
DHSVOP_VS	69	GNDA	188
DCLK/VOP_CLK	70	GNDA	187
PBIAS	71	GNDA	186
PPWR	72	GNDA	185
AVSS_LV	73	GNDA	184
AVDD_LV_33	74	GNDA	183
CH8P_LV_ER0	75	GNDA	182
CH8N_LV_ER1	76	GNDA	181
CLKP_LV_ER2	77	GNDA	180
CLKN_LV_ER3	78	GNDA	179
CH8N_LV_ER4	79	GNDA	178
CH8N_LV_ER5	80	GNDA	177
CH1P_LV_ER6	81	GNDA	176
CH1N_LV_ER7	82	GNDA	175
CH0P_LV_ER8	83	GNDA	174
CH0N_LV_ER9	84	GNDA	173
AVSS_OUT_LV	85	GNDA	172
AVDD_OUT_LV_33	86	GNDA	171
CH8P_LV_OIG2	87	GNDA	170
CH8N_LV_OIG3	88	GNDA	169
CLKP_LV_OIG4	89	GNDA	168
CLKN_LV_OIG5	90	GNDA	167
CH2P_LV_OIG6	91	GNDA	166
CH2N_LV_OIG7	92	GNDA	165
CH1P_LV_OIB0	93	GNDA	164
CH1N_LV_OIB1	94	GNDA	163
CH0P_LV_OIB2	95	GNDA	162
CH0N_LV_OIB3	96	GNDA	161
AVSS_OUT_LV	97	GNDA	160
AVDD_OUT_LV_33	98	GNDA	159
PD21/B5/GPIO46	99	GNDA	158
PD21/B5/GPIO46	100	GNDA	157
PD22/B6/GPIO47	101	GNDA	156
PD23/B7/GPIO48	102	GNDA	155
CVDD_18	103	GNDA	154
CRVSS	104	GNDA	153
GPIO48/A18	105	GNDA	152
ROM_SCsV/ROM_CSn	106	GNDA	151
ROM_SCLK/A17	107	GNDA	150
ROM_SDO/A16/OPM2	108	GNDA	149
ROM_SDI/A15/OPM1	109	GNDA	148
RVDD_33	110	GNDA	147
CRVSS	111	GNDA	146
EXT_ADC_CLAMP/A15/OPM1	112	GNDA	145
XOSD_CLK/A14/OPM0	113	GNDA	144
XOSD_HSA/13/FS1	114	GNDA	143
XOSD_VSA/12/FS0	115	GNDA	142
XOSD_FLD/A11/FT1	116	GNDA	141
VBI_DATA_7/A10/IFD0	117	GNDA	140
VBI_DATA_6/B12	118	GNDA	139
VBI_DATA_5/B12	119	GNDA	138
VBI_DATA_4/B12	120	GNDA	137
VBI_DATA_3/A6/GPO2/OSCC_SEL	121	GNDA	136
VBI_DATA_2/A5/GPIO21	122	GNDA	135
VBI_DATA_1/A4/GPIO20	123	GNDA	134
VBI_VALID/A3/GPIO19	124	GNDA	133
VBI_VALID/A2/GPIO18	125	GNDA	132
VBI_CLK/A1/GPIO17	126	GNDA	131
D0/VID2_0	127	GNDA	130
RVDD_33	128	GNDA	129
VREFN	192	GNDA	192
GND_AUD1	191	GNDA	191
LS_OUT_SW	190	GNDA	190
LS_OUT_R	189	GNDA	189
LS_OUT_L	188	GNDA	188
VDD_AUD1_33	187	GNDA	187
AUD_OUT_R	186	GNDA	186
AUD_OUT1_L	185	GNDA	185
AUD_OUT1_R	184	GNDA	184
AUD_OUT2_L	183	GNDA	183
GND_HP	182	GNDA	182
AUD_HP_OUT_R	181	GNDA	181
AUD_HP_OUT_L	180	GNDA	180
VDD_HP_33	179	GNDA	179
HDMI_GND	178	GNDA	178
HDMI_REXT	177	GNDA	177
HDMI_18	176	GNDA	176
HDMI_GND	175	GNDA	175
HDMI_RX2P	174	GNDA	174
HDMI_RX2N	173	GNDA	173
HDMI_33	172	GNDA	172
HDMI_RX1P	171	GNDA	171
HDMI_RX1N	170	GNDA	170
HDMI_GND	169	GNDA	169
HDMI_18	168	GNDA	168
HDMI_GND	167	GNDA	167
HDMI_RX0P	166	GNDA	166
HDMI_RX0N	165	GNDA	165
HDMI_33	164	GNDA	164
HDMI_RXCP	163	GNDA	163
HDMI_RXCN	162	GNDA	162
HDMI_GND	161	GNDA	161
HDMI_18	160	GNDA	160
CRVSS	159	GNDA	159
CVDD_18	158	GNDA	158
HDMI_12C_SCL	157	GNDA	157
HDMI_12C_SDA	156	GNDA	156
CEC/JTAG_TDI	155	GNDA	155
HPD/JTAG_TDO	154	GNDA	154
CRVSS	153	GNDA	153
RVDD_33	152	GNDA	152
VID_CLK_1	151	GNDA	151
VID_DATA_IN_7	150	GNDA	150
VID_DATA_IN_6	149	GNDA	149
VID_DATA_IN_5	148	GNDA	148
VID_DATA_IN_4	147	GNDA	147
VID_DATA_IN_3	146	GNDA	146
VID_DATA_IN_2	145	GNDA	145
CRVSS	144	GNDA	144
CVDD_18	143	GNDA	143
VID_DATA_IN_1	142	GNDA	142
VID_DATA_IN_0	141	GNDA	141
D7/VID2_7	140	GNDA	140
D6/VID2_6	139	GNDA	139
D5/VID2_5	138	GNDA	138
D4/VID2_4	137	GNDA	137
D3/VID2_3	136	GNDA	136
CRVSS	135	GNDA	135
CVDD_18	134	GNDA	134
D2/VID2_2	133	GNDA	133
CRVSS	132	GNDA	132
CVDD_18	131	GNDA	131
D1/VID2_1	130	GNDA	130
CRVSS	129	GNDA	129

IC BLOCK DIAGRAMS AND TERMINAL DESCRIPTIONS-21

Q8001 : FLI30502 (LCD TV Controller with Worldwide Standard Sound Processor and HDMI Receiver)-3/12

TERMINAL DESCRIPTION

<Note>

I/O Legend : A = Analog, I = Input, O = Output, P = Power, G = Ground, D = Digital

Analog input port

Pin Name	Pin #	I/O	Description
VDD18_ABC_SC	208	AP	Analog Power (1.8V) for ABC & SYNC Channel. Must be bypassed with 0.1 uF capacitor to the analog system ground plane.
GND18_ABC_SC	209	AG	Analog Ground (1.8V Return) for ABC & SYNC channel. Must be directly connected to the analog system ground plane.
VDDA	210	AP	Analog Power (3.3V) for ADC. Must be bypassed with 0.1uF capacitor to the analog system ground plane.
SIF_RTN	211	AI	Sound Intermediate frequency input 2.
GND A	212	AG	Analog ground. Must be directly connected to the analog system ground plane on board.
SIF_RTN	213	AG	Analog ground. Routed through 56E to the analog system ground plane on board.
GND A	214	AG	Analog ground. Must be directly connected to the analog system ground plane on board.
SIF_IN1	215	AI	Sound Intermediate frequency input 1.
VDDA	216	AP	Analog Power (3.3V) for ADC. Must be bypassed with 0.1uF capacitor to the analog system ground plane.
SV1P	217	AI	Positive analog input for channel 1. The input has to be AC coupled using a series 20 resistor and 0.1uF Capacitor network.
VDDA	218	AP	Analog Power (3.3V) for ADC. Must be bypassed with 0.1uF capacitor to the analog system ground plane.
A1P	219	AI	Positive analog input 'A' for channel 1. The input has to be AC coupled using a series 20 resistor and 0.1uF Capacitor network.
GND A	220	AG	Analog ground. Must be directly connected to the analog system ground plane on board.
B1P	221	AI	Positive analog input 'B' for channel 1. The input has to be AC coupled using a series 20 resistor and 0.1uF Capacitor network.
GND A	222	AG	Analog ground. Must be directly connected to the analog system ground plane on board.
C1P	223	AI	Positive analog input 'C' for channel 1. The input has to be AC coupled using a series 20 resistor and 0.1uF Capacitor network.
GND A	224	AG	Analog ground. Must be directly connected to the analog system ground plane on board.
AN	225	AI	Negative analog input 'A' for channel 1 through 4. This acts as the return Path for the Sources connected to channel -A Inputs. This has to be AC coupled using a series 57.6 ohm resistor and 0.1uF capacitor network to Analog Ground Plane on board.
GND A	226	AG	Analog ground. Must be directly connected to the analog system ground plane on board.
SV2P	227	AI	Positive analog input for channel 2. The input has to be AC coupled using a series 20 resistor and 0.1uF Capacitor network.
VDDA	228	AP	Analog Power (3.3V) for ADC. Must be bypassed with 0.1uF capacitor to the analog system ground plane.
A2P	229	AI	Positive analog input 'A' for channel 2. The input has to be AC coupled using a series 20 resistor and 0.1uF Capacitor network.
VDDA	230	AG	Analog Power (3.3V) for ADC. Must be bypassed with 0.1uF capacitor to the analog system ground plane.
B2P	231	AI	Positive analog input 'B' for channel 2. The input has to be AC coupled using a series 20 resistor and 0.1uF Capacitor network.
GND A	232	AG	Analog ground. Must be directly connected to the analog system ground plane on board.
C2P	233	AI	Positive analog input 'C' for channel 2. The input has to be AC coupled using a series 20 resistor and 0.1uF Capacitor network.
GND A	234	AG	Analog ground. Must be directly connected to the analog system ground plane on board.

IC BLOCK DIAGRAMS AND TERMINAL DESCRIPTIONS-22

Q8001 : FLI30502 (LCD TV Controller with Worldwide Standard Sound Processor and HDMI Receiver)-4/12

TERMINAL DESCRIPTION

Analog input port

Pin Name	Pin #	I/O	Description
BN	235	AI	Negative analog input 'B' for channels 1 through 4. This acts as the return Path for the Sources connected to channel-B Input. This has to be AC coupled using a series 57.6 resistor and 0.1 uF Capacitor network to Analog Ground Plane on board.
GNDA	236	AG	Analog Ground. Must be directly connected to the analog system ground plane on board.
SV3P	237	AI	Positive analog input for channel 3. The input has to be AC coupled using a series 20 resistor and 0.1uF Capacitor network.
VDDA	238	AP	Analog Power (3.3V) for ADC. Must be bypassed with 0.1uF capacitor to the analog system ground plane.
A3P	239	AI	Positive analog input 'A' for channel 3. The input has to be AC coupled using a series 20 resistor and 0.1uF Capacitor network.
VDDA	240	AP	Analog Power (3.3V) for ADC. Must be bypassed with 0.1uF capacitor to the analog system ground plane.
B3P	241	AI	Positive analog input 'B' for channel 3. The input has to be AC coupled using a series 20 resistor and 0.1uF Capacitor network.
GNDA	242	AG	Analog Ground. Must be directly connected to the analog system ground plane on board.
C3P	243	AI	Positive analog input 'C' for channel 3. The input has to be AC coupled using a series 20 resistor and 0.1uF Capacitor network.
GNDA	244	AG	Analog Ground. Must be directly connected to the analog system ground plane on board.
CN	245	AI	Negative analog input 'C' for channels 1 through 4. This acts as the return Path for the Sources connected to channel-B Input. This has to be AC coupled using a series 57.6 resistor and 0.1 uF Capacitor network to Analog Ground Plane on board.
GNDA	246	AG	Analog Ground. Must be directly connected to the analog system ground plane on board.
SV4P	247	AI	Positive analog input for channel 4. The input has to be AC coupled using a series 20 resistor and 0.1uF Capacitor network.
GNDA	248	AG	Analog Ground. Must be directly connected to the analog system ground plane on board.
A4P	249	AI	Positive analog input 'A' for channel 4. The input has to be AC coupled using a series 20 resistor and 0.1uF Capacitor network.
GNDA	250	AG	Analog Ground. Must be directly connected to the analog system ground plane on board.
B4P	251	AI	Positive analog input 'B' for channel 4. The input has to be AC coupled using a series 20 resistor and 0.1uF Capacitor network.
GNDA	252	AG	Analog Ground. Must be directly connected to the analog system ground plane on board.
C4P	253	AI	Positive analog input 'C' for channel 4. The input has to be AC coupled using a series 20 resistor and 0.1uF Capacitor network.
VDDA	254	AP	Analog Power(3.3V) for ADC. Must be bypassed with 0.1uF capacitor to the analog system ground plane.
SVN	255	AI	Negative analog SV input for channels 1 through 4. This acts as the return Path for the Sources connected to SV channel inputs. This has to be AC coupled using a series 57.6 resistor and 0.1uF Capacitor network to Analog Ground Plane on board.
VOUT2	256	AO	Analog VOUT signal. This is the Analog Video Output from the selectable Composite and S-video Inputs. This can be amplified and be any video display device.

IC BLOCK DIAGRAMS AND TERMINAL DESCRIPTIONS-23

Q8001 : FLI30502 (LCD TV Controller with Worldwide Standard Sound Processor and HDMI Receiver)-5/12

TERMINAL DESCRIPTION

Low bandwidth ADC input port

Pin Name	Pin #	I/O	Description
VDDA33_LBADC	1	AP	Analog Power (3.3V) for Low Bandwidth ADC Block. Must be bypassed with a 0.1 uF capacitor.
LBADC_IN1	2	AI	Low Bandwidth Analog input 1. The input signal connected to this pin, must be bypassed with a 0.1 uF capacitor and could be in the range of 0 to 3.3V. (peak to peak)
LBADC_IN2	3	AI	Low Bandwidth Analog input 2. The input signal connected to this pin, must be bypassed with a 0.1 uF capacitor and could be in the range of 0 to 3.3V. (peak to peak)
LBADC_IN3	4	AI	Low Bandwidth Analog input 3. The input signal connected to this pin, must be bypassed with a 0.1 uF capacitor and could be in the range of 0 to 3.3V. (peak to peak)
LBADC_IN4	5	AI	Low Bandwidth Analog input 4. The input signal connected to this pin, must be bypassed with a 0.1 uF capacitor and could be in the range of 0 to 3.3V. (peak to peak)
LBADC_IN5	6	AI	Low Bandwidth Analog input 5. The input signal connected to this pin, must be bypassed with a 0.1 uF capacitor and could be in the range of 0 to 3.3V. (peak to peak)
VSSA3_LBADC	7	AG	This pin provides the Return Path for LBADC inputs. Must be directly connected to the analog system ground plane on board.

RCLK PLL Pins

Pin Name	Pin #	I/O	Description
VBUFC_RPLL	9	O	Test Output. Leave this pin open. This reserved for factory testing purpose.
VDD_RPLL_18	10	DP	Digital power (1.8V) for ADC digital logic. Must be bypassed with capacitor to ground plane.
GND_RPLL_18	11	DG	Digital GND for ADC clocking circuit. Must be directly connected to the digital system ground plane.
XTAL	12	AO	Crystal oscillator output. Connect to external crystal.
TCLK	13	AI	Reference clock (TCLK) from the 19.6608 MHz crystal oscillator. Connect to external crystal oscillator.
AVDD_RPLL_33	14	AP	Analog Power (3.3V) for RCLK PLL. Must be bypassed with a 0.1 uF capacitor.

Digital video Input port

Pin Name	Pin #	I/O	Description
VID_CLK_1	151	I	Video port data clock input meant for Video Input 1. Up to 135 MHz (Input, 5 V tolerant).
VIDIN_HS	53	I	When Video Input 1 is in BT656 mode, this pin acts as HSync Input for Video Input 2;
VIDIN_VS	54	I	When Video Input 1 is in BT656 mode, this pin acts as VSync Input for Video Input 2;
VID_DATA_IN_0	141	IO	Input YUV data in 8-bit BT656 of Video Input 1 (Bidirectional, 5 V tolerant); or Y[0:7] in 16-bit format or Y/G[0:7] in 24-bit format
VID_DATA_IN_1	142		
VID_DATA_IN_2	145		
VID_DATA_IN_3	146		
VID_DATA_IN_4	147		
VID_DATA_IN_5	148		
VID_DATA_IN_6	149		
VID_DATA_IN_7	150		
VID_DATA_IN_8	162	IO	Input C [0:7] data in 16-bit format OR B/U in 24-bit format
VID_DATA_IN_9	163		
VID_DATA_IN_10	165		
VID_DATA_IN_11	166		
VID_DATA_IN_12	170		
VID_DATA_IN_13	171		
VID_DATA_IN_14	173		
VID_DATA_IN_15	174		

IC BLOCK DIAGRAMS AND TERMINAL DESCRIPTIONS-24

Q8001 : FLI30502 (LCD TV Controller with Worldwide Standard Sound Processor and HDMI Receiver)-6/12

TERMINAL DESCRIPTION

Digital video Input port

Pin Name	Pin #	I/O	Description
VID2_0/VID_DATA_IN_16	127	IO	Video Input 2 in 8-bit with Embedded Sync / Separate Sync format OR R/V data in 24-bit format.
VID2_1/VID_DATA_IN_17	130		
VID2_2/VID_DATA_IN_18	133		
VID2_3/VID_DATA_IN_19	136		
VID2_4/VID_DATA_IN_20	137		
VID2_5/VID_DATA_IN_21	138		
VID2_6/VID_DATA_IN_22	139		
VID2_7/VID_DATA_IN_23	140		
VID2_CLK	55	I	Video port data clock input meant for Video Input 2. Up to 135 MHz (Input, 5V tolerant).
VID_DE/FLD	56	I	Video Active Signal Input or the Field Signal Input from external Digital Video Source.

System interface

Pin Name	Pin #	I/O	Description
RESETn	8	I	Hardware Reset (active low, Shmitt trigger, 5V tolerant).
STI_TM2	17	I	For normal mode of operation connect this pin to ground. It has an internal pull down resistor of 50 k.
GPIO15/STI_TMI/ EXT_CS _n	18	IO	This pin is available as a general purpose input / output port. It is also optionally programmable to give out the external SRAM. Connect pull up resistor to supply when an external SRAM is used.
SCART16	19	I	Can be programmed to sense the Fast Blank input signal from a SCART input source.
HOST_SCLK/ UART_DI/JTAG_CLK	22	IO	Host input clock or 186 UART Data In or JTAG clock signal (Input, Schmitt trigger, 5V tolerant).
HOST_SDATA/ UART_DO/JTAG_MODE	23	IO	Host input data or 186 UART Data Out or JATA mode signal (Bidirectional, Schmitt trigger, slew rate limited, 5 V tolerant).
DDC_SCLK	24	IO	DDC2BI clock for VGA port.
DDC_SDATA	25	IO	DDC2BI data for VGA port.
MSTR_SCLK	28	O	Clock signal from Master Serial 2-Wire Interface Controller.
MSTR_SDATA	29	IO	Data signal meant for Master Serial 2-Wire Interface Controller.
GPIO0	32	IO	This pin is available as a General Purpose Input / Output Port.
GPIO1	33	IO	This pin is available as a General Purpose Input / Output Port.
GPIO2	34	IO	This pin is available as a General Purpose Input / Output Port.
GPIO3	35	IO	This pin is available as a General Purpose Input / Output Port.
GPIO6/IRin	36	IO	Input from Infrared Decoder can be connected to this pin. This pin is also available as a General Purpose Input / Output port.
GPIO7/IRQin	39	IO	Input interrupt Request signal can be connected to this pin. This pin is also available as a General Purpose Input / Output port.
GPO8/IRout	40	IO	This pin will give out the Interrupt Signal to interrupt external micro. This pin is also available as a General Purpose Output port.
GPIO9/SIPC_SCLK/ A19	41	IO	This pin accepts the clock signal from an external serial 2-wire interface bus if FLI30502 is programmed to be in Slave mode. This pin programmable to give out Address line 19 from the Internal Micro when used with 1 MB and 2 MB External Memory. This pin is also available as a General Purpose Input / Output Port.
GPIO10/ SIPC_SDATA/A20	42	IO	This pin acts as the Data I/O signal when used with external serial 2-wire interface bus if FLI30502 is programmed to be in Slave mode. This pin is programmable to give out Address line 20 from the Internal Micro when used with 2 MB External Memory. This pin is available as a General purpose Input / Output port.

IC BLOCK DIAGRAMS AND TERMINAL DESCRIPTIONS-25

Q8001 : FLI30502 (LCD TV Controller with Worldwide Standard Sound Processor and HDMI Receiver)-7/12

TERMINAL DESCRIPTION

System interface

Pin Name	Pin #	I/O	Description
GPIO11/PWM0	45	IO	This Pin can be programmed to give out Pulse Width Modulated Output Pulses for eternal use. This pin is also available as a General Purpose Input / Output Port.
GPIO12/PWM1	46	IO	This Pin can be programmed to give out Pulse Width Modulated Output Pulses for eternal use. This pin is also available as a General Purpose Input / Output Port.
GPIO13/PWM2/ 656_VBI_VALID/ JTAG_RESET	49	IO	This pin can programmed to give out Pulse Width Modulated Output Pulses for external use. This pin is also available as a General Purpose Input / Output Port. This is also used for JTAG reset.
GPIO14/PWM3/ SCART16_1	50	IO	This pin can programmed to give out Pulse Width Modulated Output Pulses for external use. It can be programmed to sense the Fast Blank Input signal from a SCART input source. This pin is also available as a General Purpose Input / Output Port.
HSYNC1_VGA	16	I	Horizontal Sync signal Input 1. Used when Analog RGB component signal carries separate HSync signal. It has a programmable Schmitt trigger.
VSYNC1_VGA	15	I	Vertical Sync signal Input 1. Used when Analog RGB component signal carries separate VSync signal. It has a programmable Schmitt trigger.
XOSD_CLK	113	O	Clock Output meant for External OSD Controller.
XOSD_HS	114	O	Horizontal Sync Output meant for External OSD Controller.
XOSD_VS	115	O	Vertical Sync Output meant for External OSD Controller.
XOSD_FLD	116	O	Field Signal Output meant for External OSD Controller.
PD20/B4/GPIO45	99	IO	These pins provide the Panel Data as shown in the Table 10, TTL Display Interface. These are available as General Purpose Input / Output Pins when not used as Panel Data.
PD21/B5/GPIO46	100		
PD22/B6/GPIO47	101		
PD23/B7/GPIO48	102		
GPIO36/JTAG_TDO	154	IO	This pin available as a General Purpose Input/Output port. This is also used for JTAG TDO.
GPIO36/JTAG_TDI	155	IO	This pin available as a General Purpose Input/Output port. This is also used for JTAG TDI.
GPIO34	156	IO	This pin available as a general purpose Input/Output port.
GPIO33	157	IO	This pin available as a general purpose Input/Output port.
GPIO24	160	IO	This pin available as a general purpose Input/Output port.
GPIO25	161	IO	This pin available as a general purpose Input/Output port.
GPIO26	164	IO	This pin available as a general purpose Input/Output port.
GPIO27	167	IO	This pin available as a general purpose Input/Output port.
GPIO28	168	IO	This pin available as a general purpose Input/Output port.
GPIO29	169	IO	This pin available as a general purpose Input/Output port.
GPIO30	176	IO	This pin available as a general purpose Input/Output port.
GPIO31	177	IO	This pin available as a general purpose Input/Output port.
GPIO32	178	IO	This pin available as a general purpose Input/Output port.

IC BLOCK DIAGRAMS AND TERMINAL DESCRIPTIONS-26

Q8001 : FLI30502 (LCD TV Controller with Worldwide Standard Sound Processor and HDMI Receiver)-8/12

TERMINAL DESCRIPTION

LVDS Display interface

Pin Name	Pin #	I/O	Description
PBIAS	71	O	Panel Bias Control (backlight enable, tri-state output, 5 V tolerant).
PPWR	72	O	Panel Power Control (tri-state output, 5 V tolerant).
AVDD_LV_33	74	DP	Digital Power for LVDS Block. Connect to digital 3.3V supply.
AVSS_LV	73	G	Ground for LVDS outputs.
CH3P_LV_E	75	O	These form the Differential Data Output for Channel 3 (Even).
CH3N_LV_E	76	O	
CLKP_LV_E	77	O	These form the Differential Clock Output Even Channel.
CLKN_LV_E	78	O	
CH2P_LV_E	79	O	These form the Differential Data Output for Channel 2 (Even).
CH2N_LV_E	80	O	
CH1P_LV_E	81	O	These form the Differential Data Output for Channel 1 (Even).
CH1N_LV_E	82	O	
CH0P_LV_E	83	O	These form the Differential Data Output for Channel 0 (Even).
CH0N_LV_E	84	O	
VSS_OUT_LV	85	G	Ground for LVDS outputs.
VDD_OUT_LV_33	86	DP	Digital Power for LVDS outputs. Connect to digital 3.3 V supply.
CH3P_LV_O	87	O	These form the Differential Data Output for Channel 3 (Odd).
CH3N_LV_O	88	O	
CLKP_LV_O	89	O	These form the Differential Clock Output Odd Channel.
CLKN_LV_O	90	O	
CH2P_LV_O	91	O	These form the Differential Data Output for Channel 2 (Odd).
CH2N_LV_O	92	O	
CH1P_LV_O	93	O	These form the Differential Data Output for Channel 1 (Odd).
CH1N_LV_O	94	O	
CH0P_LV_O	95	O	These form the Differential Data Output for Channel 0 (Odd).
CH0N_LV_O	96	O	
AVSS_OUT_LV	97	G	Ground for LVDS outputs.
AVDD_OUT_LV_33	98	DP	Digital Power for LVDS outputs. Connect to digital 3.3 V supply.

IC BLOCK DIAGRAMS AND TERMINAL DESCRIPTIONS-27

Q8001 : FLI30502 (LCD TV Controller with Worldwide Standard Sound Processor and HDMI Receiver)-9/12

TERMINAL DESCRIPTION

TTL Display interface

Pin Name	Pin #	I/O	Description	
			8-Bit Panels	6-Bit Panels
PBIAS	71	O	Panel Bias Control (backlight enable, tri-state output, 5 V tolerant).	
PPWR	72	O	Panel Power Control (tri-state output, 5 V tolerant).	
AVDD_LV_33	74	---	Digital Power for LVDS Block. Connect to digital 3.3V supply.	
AVSS_LV	73	---	Ground for TTL outputs.	
R0	75	O	Red channel bit 0 (Even).	Not used.
R1	76	O	Red channel bit 1 (Even).	Not used.
R2	77	O	Red channel bit 2 (Even).	Red channel bit 0 (Even).
R3	78	O	Red channel bit 3 (Even).	Red channel bit 1 (Even).
R4	79	O	Red channel bit 4 (Even).	Red channel bit 2 (Even).
R5	80	O	Red channel bit 5 (Even).	Red channel bit 3 (Even).
R6	81	O	Red channel bit 6 (Even).	Red channel bit 4 (Even).
R7	82	O	Red channel bit 7 (Even).	Red channel bit 5 (Even).
G0	83	O	Green channel bit 0 (Even).	Not used.
G1	84	O	Green channel bit 1 (Even).	Not used.
AVSS_OUT_LV	85	G	Ground for TTL outputs.	
AVDD_OUT_LV_33	86	DP	Digital Power for TTL outputs. Connect to digital 3.3 V supply.	
G2	87	O	Green channel bit 2 (Even).	Green channel bit 0 (Even).
G3	88	O	Green channel bit 3 (Even).	Green channel bit 1 (Even).
G4	89	O	Green channel bit 4 (Even).	Green channel bit 2 (Even).
G5	90	O	Green channel bit 5 (Even).	Green channel bit 3 (Even).
G6	91	O	Green channel bit 6 (Even).	Green channel bit 4 (Even).
G7	92	O	Green channel bit 7 (Even).	Green channel bit 5 (Even).
B0	93	O	Blue channel bit 0 (Even).	Not used.
B1	94	O	Blue channel bit 1 (Even).	Not used.
B2	95	O	Blue channel bit 2 (Even).	Blue channel bit 0 (Even).
B3	96	O	Blue channel bit 3 (Even).	Blue channel bit 1 (Even).
AVSS_OUT_LV	97	G	Ground for TTL outputs.	
AVDD_OUT_LV_33	98	DP	Digital Power for TLL outputs. Connect to digital 3.3 V supply.	
PD20/B4	99	O	Blue channel bit 4 (Even).	Blue channel bit 2 (Even).
PD21/B5	100	O	Blue channel bit 5 (Even).	Blue channel bit 3 (Even).
PD22/B6	101	O	Blue channel bit 6 (Even).	Blue channel bit 4 (Even).
PD23/B7	102	O	Blue channel bit 7 (Even).	Blue channel bit 5 (Even).
DEN	67	O	Display Data Enable.	
DHS	68	O	Display Horizontal Sync.	
DVS	69	O	Display vertical Sync.	
DCLK	70	O	Display Pixel Clock.	

Parallel / Serial ROM interface

Pin Name	Pin #	I/O	Description
A20	42	O	Address Signal A20 for 2M x 8 PROM. This pin also acts as GPIO10.
A19	41	O	Address Signal A19 for 1M x 8 PROM / 2M x 8 PROM. This pin also acts as GPIO9.
A18	105	O	Address Signal A18 for 512K x 8 PROM / SRAM. This pin also acts as GPIO49.

IC BLOCK DIAGRAMS AND TERMINAL DESCRIPTIONS-28

Q8001 : FLI30502 (LCD TV Controller with Worldwide Standard Sound Processor and HDMI Receiver)-10/12

TERMINAL DESCRIPTION

Parallel / Serial ROM interface

Pin Name	Pin #	I/O	Description
A17	107	O	256K x 8 PROM / SRAM Address. Some of these pins also have boot strap functionality. For serial SPI ROM interface : - ROM_ADDR17 is Serial Clock (ROM_SCLK) - ROM_ADDR16 is Serial Data Output (ROM_SDO)
A16	108		
A15	112		
A14	113		
A13	114		
A12	115		
A11	116		
A10	117		
A9	118		
A8	119		
A7	120		
A6	121		
A5	122		
A4	123		
A3	124		
A2	125		
A1	126		
A0	56		
D7	140	IO	External PROM / SRAM data input.
D6	139		
D5	138		
D4	137		
D3	136		
D2	133		
D1	130		
D0	127		
ROM_OEN	55	O	External PROM / SRAM Data Output Enable.
ROM_SDI/ ROM_WEN	109	O	External PROM / SRAM Data Write Enable (for In-System Programming of Flash) or Serial Data Input (SDI) for SPI ROM interface.
ROM_SCSN/ ROM_CSN	106	O	External PROM / SRAM Data Chip Select or Serial PROM Chip Select (ROM_SCSN) for for SPI ROM interface.

IC BLOCK DIAGRAMS AND TERMINAL DESCRIPTIONS-29

Q8001 : FLI30502 (LCD TV Controller with Worldwide Standard Sound Processor and HDMI Receiver)-11/12

TERMINAL DESCRIPTION

Digital Power and Ground

Pin Name	Pin #	I/O	Description
RVDD_3.3	30	P	Ring VDD. Connect to digital 3.3 V.
	47		
	110		
	128		
	152		
	172		
CVDD_1.8	20	P	Core VDD. Connect to digital 3.3V.
	26		
	37		
	43		
	51		
	65		
	103		
	131		
	134		
	143		
CRVSS	21	G	Chip ground for core and ring.
	27		
	31		
	38		
	44		
	48		
	52		
	66		
	104		
	111		
	129		
	132		
	135		
	144		
153			
159			

OCM JTAG

Pin Name	Pin #	I/O	Description
JTAG_CLK	22	I	JTAG CLOCK signal
JTAG_MODE	23	O	JTAG Mode signal
JTAG_RESET	49	I	JTAG RESET aignal
JTAG_TDO	154	I	JTAG DATA OUT signal
JTAG_TDI	155	I	JTAG DATA IN signal

IC BLOCK DIAGRAMS AND TERMINAL DESCRIPTIONS-30

Q8001 : FLI30502 (LCD TV Controller with Worldwide Standard Sound Processor and HDMI Receiver)-12/12

TERMINAL DESCRIPTION

Audio Port

Pin Name	Pin #	I/O	Description
I2S_SPDIF_IN_DATA	57	DI	I2S/SPDIF Serial Data Input.
I2S_IN_WCLK	58	DI	Left / Right Channel Select Signal.
I2S_IN_BCLK	59	DI	I2S receiver works in slave mode and will receive clock from external I2S transmitter.
I2S0_SPDIF_OUT_DATA	60	DO	I2S/SPDIF Serial Data Output.
I2S_OUT_WCLK	61	DO	Left / Right Channel Select bit for I2S output.
I2S_OUT_BCLK	62	DO	Output bit clock from I2S.
I2S1_OUT_DATA	63	DO	I2S Serial Data Output.
AUDIO_CLKOUT	64	DO	Audio Clock Out for External Digital Amplifier.
GND_AUD_18	207	AG	Analog Ground (1.8 V Return) for Audio Block.
VCC_AUD_18	206	AP	Analog Power (1.8V) for Audio Block.
GND_AUD2	205	AG	Analog Ground (3.3 V return).
AUDIO_MONO_IN	204	AI	Microphone Input
AUD_IN_R1	203	AI	Line In Right channel 1
AUD_IN_L1	202	AI	Line In Left channel 1
AUD_IN_R2	201	AI	Line In Right channel 2
AUD_IN_L2	200	AI	Line In Left channel 2
AUD_IN_R3	199	AI	Line In Right channel 3
AUD_IN_L3	198	AI	Line In Left channel 3
AUD_IN_R4	197	AI	Line In Right channel 4
AUD_IN_L4	196	AI	Line In Left channel 4
VDD_AUD2_33	195	AP	Analog Power 3.3 V
VREFP	194	AP	Positive Reference Voltage for Internal Audio Codec.
VREFM	193	AP	Common Mode Reference Voltage for Internal Audio Codec.
VREFN	192	AP	Negative Reference Voltage for Internal Audio Codec.
GND_AUD1	191	AG	Analog ground (3.3V Return)
LS_OUT_SW	190	O	Main Subwoofer Speaker Output Data.
LS_OUT_R	189	O	Main Right Speaker Analog Output Data.
LS_OUT_L	188	O	Main Left Speaker Analog Output Data.
VDD_AUD1_33	187	O	Analog Power 3.3V
AUD_OUT1_R	186	O	Line Out Right Channel 1 (SCART / Monitorout)
AUD_OUT1_L	185	O	Line Out Left Channel 1 (SCART / Monitorout)
AUD_OUT2_R	184	O	Line Out Right Channel 2 (SCART / Monitorout)
AUD_OUT2_L	183	O	Line Out Left Channel 2 (SCART / Monitorout)
GND_HP	182	AG	Analog Ground (3.3V Return) for both Left & Right Channel DACs on Headphone Output.
AUD_OUT_HP_R	181	O	Headphone Right Channel Analog Output data.
AUD_OUT_HP_L	180	O	Headphone Left Channel Analog Output data.
VDD_HP_33	179	AP	Analog Power(3.3V) for both Left & Right channel DACs on Headphone Output.

IC BLOCK DIAGRAMS AND TERMINAL DESCRIPTIONS-31

Q8002, Q8003 : TC74VCX162244FT

(Low-Voltage 16-Bit Bus Buffer with 3.6-V Tolerant Inputs and Outputs)

PIN LAYOUT

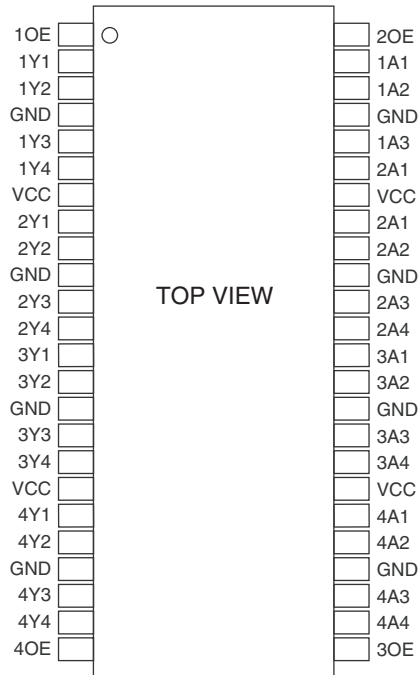

IEC LOGIC SYMBOL

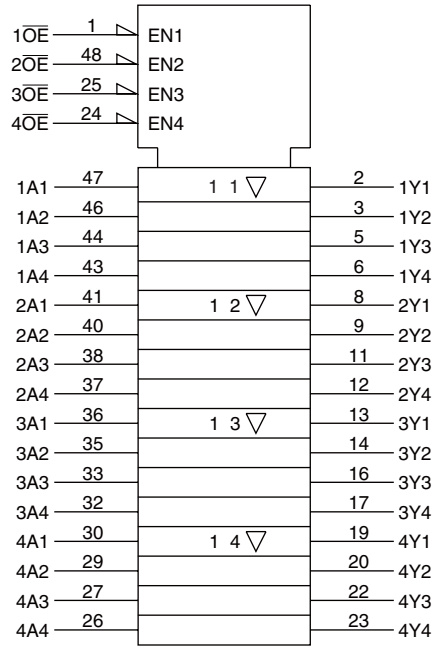

TRUTH TABLE

Inputs		Outputs
$1\overline{OE}$	1A1-1A4	1Y1-1Y4
L	L	L
L	H	H
H	X	Z

Inputs		Outputs
$2\overline{OE}$	2A1-2A4	2Y1-2Y4
L	L	L
L	H	H
H	X	Z

Inputs		Outputs
$3\overline{OE}$	3A1-3A4	3Y1-3Y4
L	L	L
L	H	H
H	X	Z

Inputs		Outputs
$4\overline{OE}$	4A1-4A4	4Y1-4Y4
L	L	L
L	H	H
H	X	Z

SYSTEM DIAGRAM

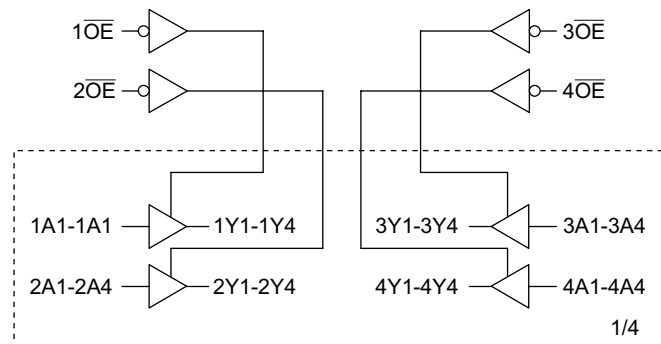

X : Don't care
Z : High impedance

IC BLOCK DIAGRAMS AND TERMINAL DESCRIPTIONS-32

Q8162 : SiI9185ACTU (Three Input, Single Output Deep Color HDMI Switch)-1/3

BLOCK DIAGRAM

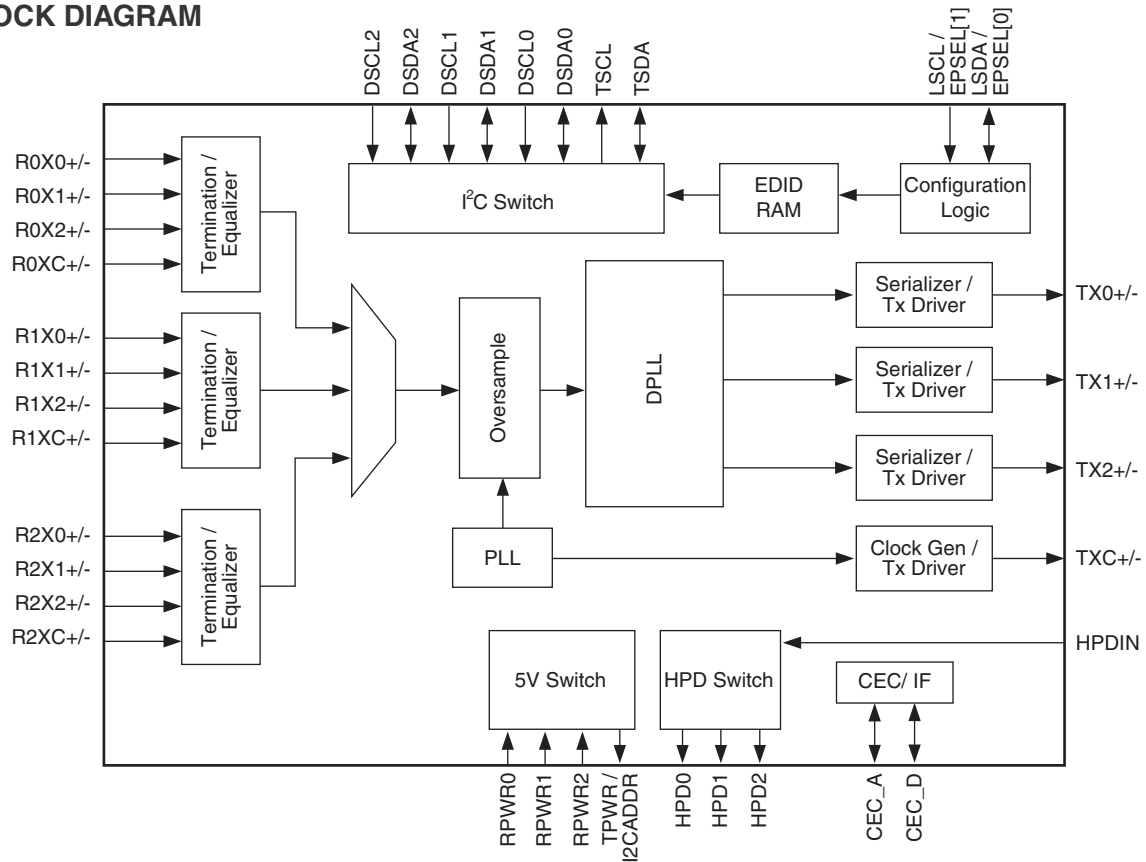

PIN LAYOUT

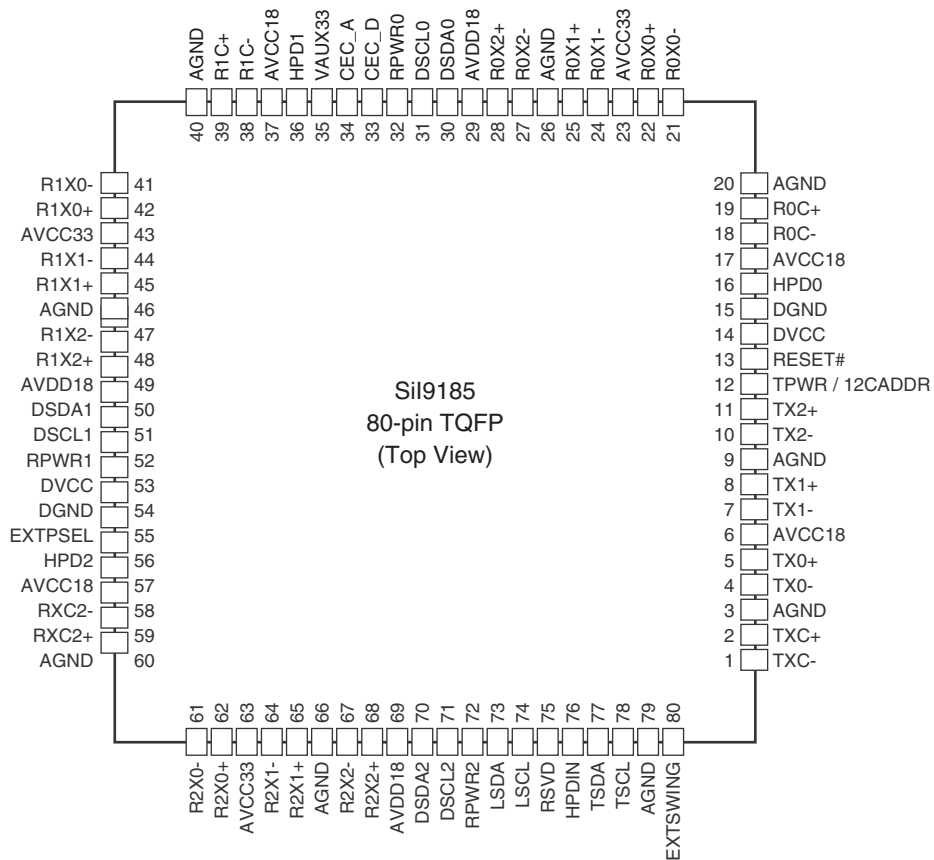

IC BLOCK DIAGRAMS AND TERMINAL DESCRIPTIONS-33

Q8162 : SiI9185ACTU (Three Input, Single Output Deep Color HDMI Switch)-2/3

TERMINAL DESCRIPTION

System switching

Pin Name	Pin #	Dir	Description
DSDA0, DSDA1, DSDA2	30, 50, 70	Input / Output	DDC I ² C Data for respective port.
DSCL0, DSCL1, DSCL2	31, 51, 71	Input	DDC I ² C Clock for respective port.
RPWR0, RPWR1, RPWR2	32, 52, 72	---	Port “ Tx detection ” input. Connect 5V input from HDMI connector.

Configuration

Pin Name	Pin #	Dir	Description
HPD0, HPD1, HPD2	16, 36, 56	Output	Hot Plug Detect Output.
HPDIN	76	Input	Hot Plug Detect Input.
TPWR / I2CADDR	12	Input / Output	Optical I2C address. When RESET # is ‘0’, pin will be used as an input to latch I2C sub-address. When RESET # is ‘1’, this pin will be used as an output for TPWR indicating selected Rx-port is alive.
EXTPSEL	55	Input	External Port selection input pin. When this pin is ‘1’ external pins, SCL_L and SDA_L, will be use to select Rx-port as ExPSEL[1:0]. When ‘0’, internal local I2C register will be used to select Rx-port.
RSVDL	75	---	Reserved for use by Silicon Image and must be tied low.

Control Pins

Pin Name	Pin #	Dir	Description
RESET #	13	Input	Reset Pin (Active LOW)
LSCL / EPSEL[1]	74	Input	Local Configuration / Status I ² C Clock. When EXTPSEL = ‘1’, local CSL will be used as External port selection pin, EPSEL[1].
LSDA / EPSEL[0]	73	Bi-Di	Local Configuration / Status I ² C Data. When EXTPSEL = ‘1’, local SDA will be used as External port selection pin, EPSEL[0].
TSCL	78	Output	Master DDC Clock (Open Drain Output) to HDMI receiver.
TSDA	77	Bi-Di	Master DDC Data (Open Drain Output) to HDMI receiver.

CEC Pins

Pin Name	Pin #	Direction	Description
CEC_A	34	Input / Output	HDMI compliant CEC I/O.
CEC_D	33	Input / Output	CEC interface to system microcontroller.

IC BLOCK DIAGRAMS AND TERMINAL DESCRIPTIONS-34

Q8162 : SiI9185ACTU (Three Input, Single Output Deep Color HDMI Switch)-3/3

TERMINAL DESCRIPTION

Differential Signal Data Pins

Pin Name	Pin #	Dir	Description
RX0+	20, 41, 62	Input	TMDS input data pairs.
RX0-	21, 42, 61	Input	
RX1+	22, 45, 65	Input	
RX1-	24, 44, 64	Input	
RX2+	28, 48, 68	Input	
RX2-	27, 47, 67	Input	
RXC+	19, 39, 59	Input	TMDS input clock pair.
RXC-	18, 38, 58	Input	
TX0+	5	Output	TMDS output data pairs.
TX0-	4	Output	
TX1+	8	Output	
TX1-	7	Output	
TX2+	11	Output	
TX2-	10	Output	
TXC+	2	Output	TMDS output clock pair.
TXC-	1	Output	
EXT_SWING	80	Input	Voltage Swing Adjust. A resistor is tied from this pin to AVCC. This resistor determines the amplitude of the voltage swing. Recommend TBD Ω .

Power and Ground Pins

Pin Name	Pin #	Type	Description
AGND	3, 9, 20, 26, 40, 46, 60, 66, 79	Ground	Analog GND.
AVCC18	6, 17, 57	Power	Analog VCC. Connect to 1.8V supply.
DVCC	14, 53	Power	Digital VCC. Connect to 1.8V supply.
DGND	15, 54	Ground	Digital GND.
AVCC33	23, 43, 63	Power	Analog VCC. Connect to 3.3V supply.
AVDD18	29, 49, 69	Power	Analog VCC. Connect to 1.8V supply.
VAUX33	35	Power	Standby VCC. Connect to 3.3V supply. This supply should always be powered for standby operation.

IC BLOCK DIAGRAMS AND TERMINAL DESCRIPTIONS-35

Q8401 : SiI9134CTU (HDMI Deep Color Transmitter)-1/4

BLOCK DIAGRAM

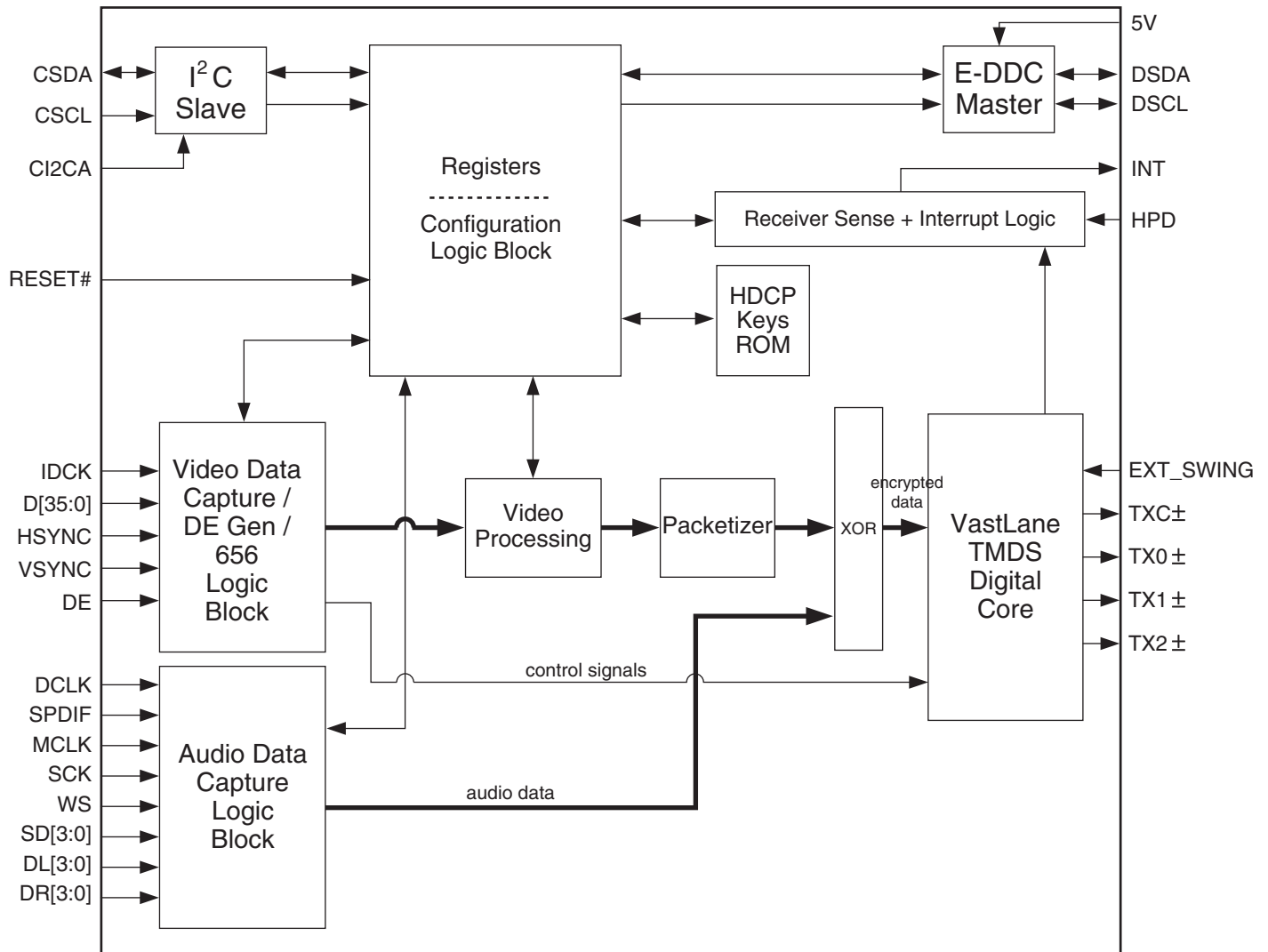

IC BLOCK DIAGRAMS AND TERMINAL DESCRIPTIONS-36

Q8401 : SiI9134CTU (HDMI Deep Color Transmitter)-2/4

PIN LAYOUT

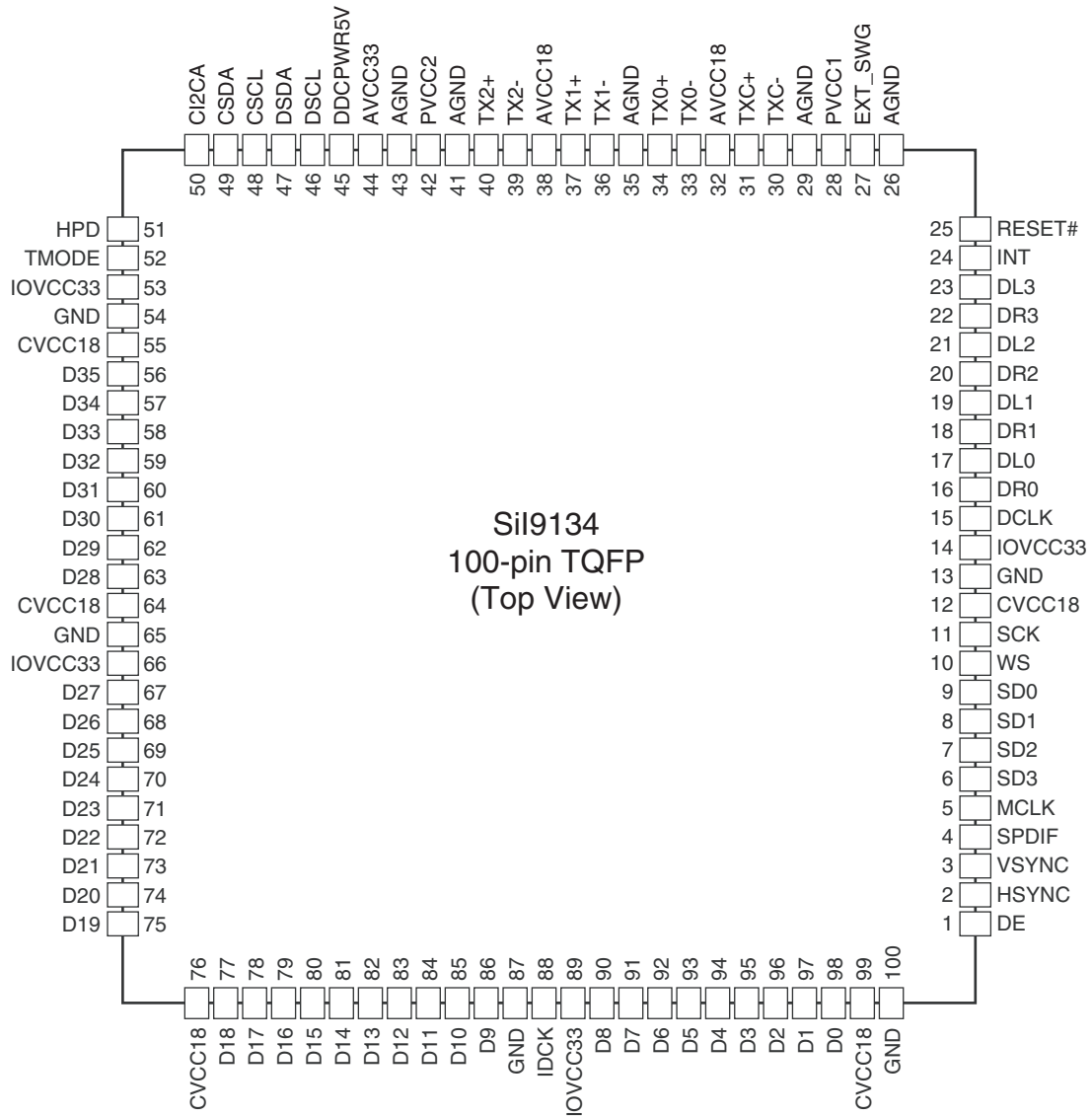

IC BLOCK DIAGRAMS AND TERMINAL DESCRIPTIONS-37

Q8401 : SiI9134CTU (HDMI Deep Color Transmitter)-3/4

TERMINAL DESCRIPTION

Video and Audio Input pins

Pin Name	Pin #	Dir	Description
D0 - D11	98 - 84	Input	These are the lower 12 bits of the 36-bit pixel bus. These pins are highly configurable, and support multiple RGB and YCbCr formats.
D12 - D23	83 - 71	Input	These are the middle 12 bits of the 36-bit pixel bus.
D24 - D35	70 - 56	Input	These are the upper 12 bits of the 36-bit pixel bus.

Video and Audio Input pins

Pin Name	Pin #	Dir	Description
IDCK	88	Input	Input Data clock
DE	1	Input	Data enable
HSYNC	2	Input	Horizontal Sync input control signal
VSYNC	3	Input	Vertical Sync input control signal
SCK	11	Input	I ² S Serial Clock
WS	10	Input	I ² S Word Select
SD0	9	Input	I ² S Serial data
SD1	8	Input	I ² S Serial data
SD2	7	Input	I ² S Serial data
SD3	6	Input	I ² S Serial data
DL0	17	Input	One-bit Audio data Left 0
DR0	16	Input	One-bit Audio data Right 0
DL1	19	Input	One-bit Audio data Left 1
DR1	18	Input	One-bit Audio data Right 1
DL2	21	Input	One-bit Audio data Left 2
DR2	20	Input	One-bit Audio data Right 2
DL3	23	Input	One-bit Audio data Left 3
DR3	22	Input	One-bit Audio data Right 3
DCLK	15	Input	One-bit Audio Clock Input
MCLK	5	Input	Audio Input Master Clock
SPDIF	4	Input	S/PDIF Audio Input.

Configuration / Programming Pins

Pin Name	Pin #	Dir	Description
HPD	51	Input	Hot Plug Detect Input.
RSVDL	52	Input	Reserved for use by Silicon Image and must be tied LOW.
INT	24	Output	Interrupt Output.

Control Pins

Pin Name	Pin #	Dir	Description
CI2CA	50	Input	I ² C device address select
RESET#	25	Input	Reset Pin (Active LOW) 5V Tolerant
CSCL	48	Input	I ² C Clock
CSDA	49	Bi-Di	I ² C Data (Open Drain Output)
DSCL	46	Bi-Di	DDC Clock (Open Drain Output)
DSDA	47	Bi-Di	DDC Data (Open Drain Output)

IC BLOCK DIAGRAMS AND TERMINAL DESCRIPTIONS-38

Q8401 : SiI9134CTU (HDMI Deep Color Transmitter)-4/4

TERMINAL DESCRIPTION

Differential Signal Data Pins

Pin Name	Pin #	Dir	Description
TX0+	34	Output	TMDS output data pairs.
TX0-	33	Output	
TX1+	37	Output	
TX1-	36	Output	
TX2+	40	Output	
TX2-	39	Output	
TXC+	31	Output	TMDS output clock pair.
TXC-	30	Output	
EXT_SWING	27	Input	Voltage Swing Adjust. A resistor is tied from this pin to AVCC. This resistor determines the amplitude of the voltage swing.

Power and Ground Pins

Pin Name	Pin #	Type	Description
CVCC18	12, 55, 64, 76, 99	Power	Digital Core VCC. Connect to 1.8V supply.
IOVCC33	14, 53, 66, 89	Power	IO Pin VCC. Connect to 3.3V supply.
AVCC33	44	Power	Analog VCC. Connect to 3.3V supply.
AVCC18	32, 38	Power	Analog VCC. Connect to 1.8V supply.
AGND	26, 29, 35, 41, 43	Ground	Analog GND.
PVCC1	28	Power	TMDS Core PLL Power. Connect to 1.8V supply.
PVCC2	42	Power	Filter PLL Power. Connect to 1.8V supply.
DDCPWR5V	45	Power	Power reference signal. Used to supply power to the DDC 0I2C pads when chip is powered off. Connect to 5V supply.
GND	13, 54, 65, 87, 100	Ground	Digital Ground.

IC BLOCK DIAGRAMS AND TERMINAL DESCRIPTIONS-39

Q8501 : SiI9135ACTU (HDMI Receiver)-1/5

BLOCK DIAGRAM

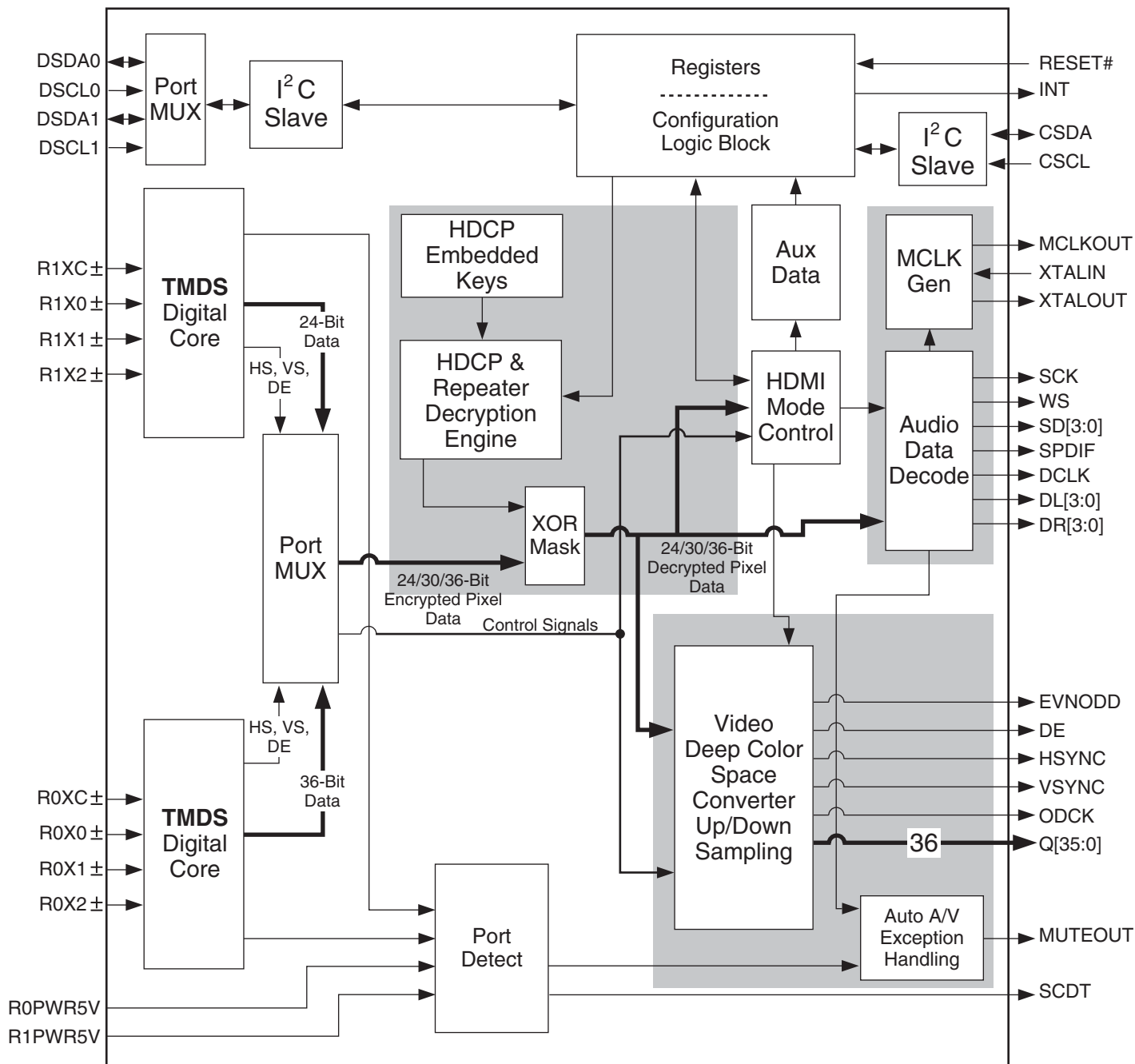

IC BLOCK DIAGRAMS AND TERMINAL DESCRIPTIONS-40

Q8501 : SiI9135ACTU (HDMI Receiver)-2/5

PIN LAYOUT

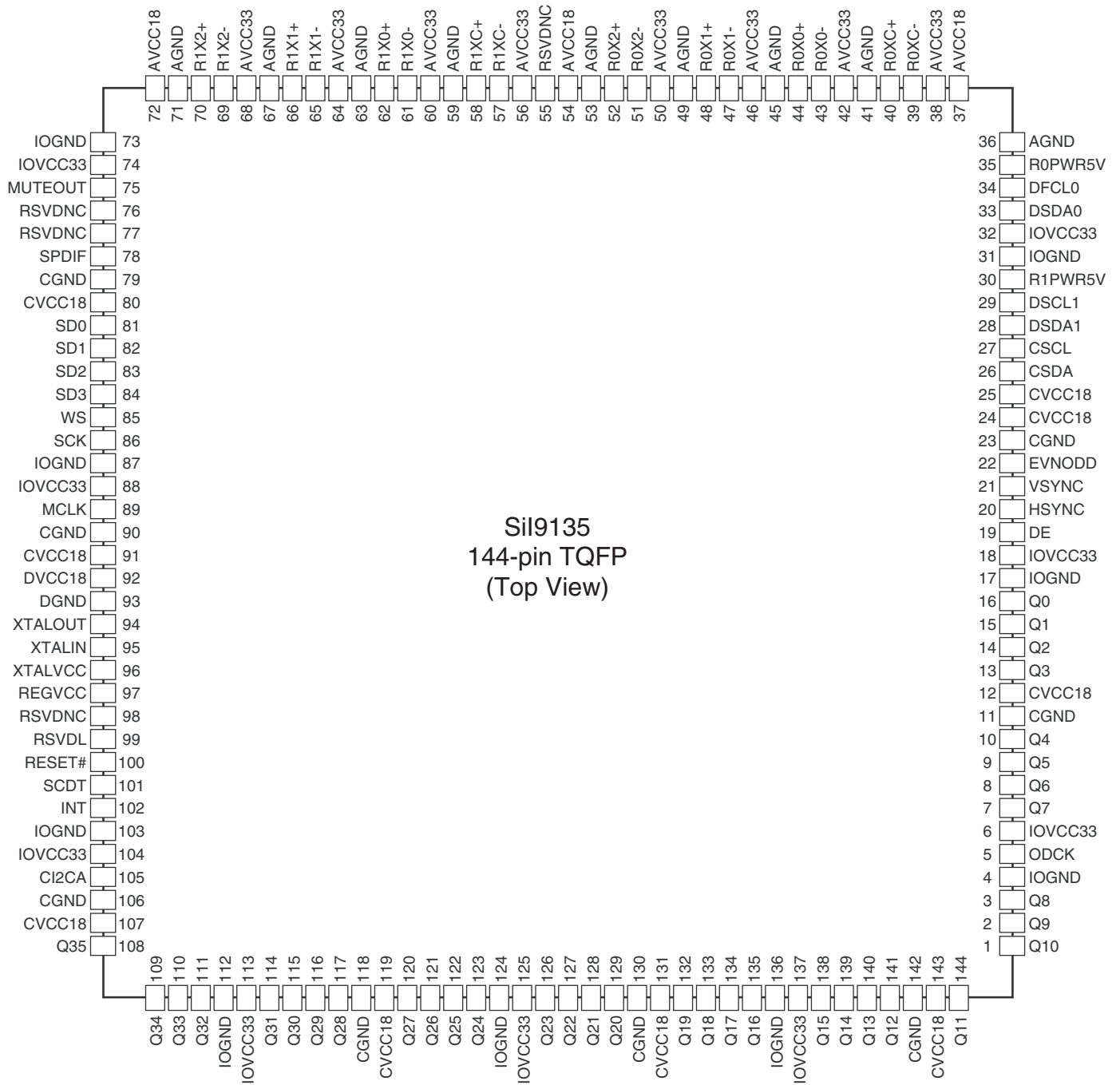

IC BLOCK DIAGRAMS AND TERMINAL DESCRIPTIONS-41

Q8501 : SiI9135ACTU (HDMI Receiver)-3/5

TERMINAL DESCRIPTION

Digital Video Output Pins

Pin Name	Pin #	Dir	Description
Q0	16	Output	36-Bit Output Pixel Data Bus. Q35:0 is highly configurable using the VDD_CONFIG register. It supports a wide array of output formats, including multiple RBG and YCbCr bus formats. Using the appropriate bits in the PD register, the output drivers can be put into a high impedance (tri-state) mode. A weak, internal pull-down device brings each output to ground.
Q1	15	Output	
Q2	14	Output	
Q3	13	Output	
Q4	10	Output	
Q5	9	Output	
Q6	8	Output	
Q7	7	Output	
Q8	3	Output	
Q9	2	Output	
Q10	1	Output	
Q11	144	Output	
Q12	141	Output	
Q13	140	Output	
Q14	139	Output	
Q15	138	Output	
Q16	135	Output	
Q17	134	Output	
Q18	133	Output	
Q19	132	Output	
Q20	129	Output	
Q21	128	Output	
Q22	127	Output	
Q23	126	Output	
Q24	123	Output	
Q25	122	Output	
Q26	121	Output	
Q27	120	Output	
Q28	117	Output	
Q29	116	Output	
Q30	115	Output	
Q31	114	Output	
Q32	111	Output	
Q33	110	Output	
Q34	109	Output	
Q35	108	Output	
DE	19	Output	Data Enable.
HSYNC	20	Output	Horizontal Sync Output.
VSYNC	21	Output	Vertical Sync Output.
EVNODD	22	Output	Indicates Even or Odd Field for Interlaced Formats.
ODCK	5	Output	Output Data Clock.

IC BLOCK DIAGRAMS AND TERMINAL DESCRIPTIONS-42

Q8501 : SiI9135ACTU (HDMI Receiver)-4/5

TERMINAL DESCRIPTION

Digital Audio Output Pins

Pin Name	Pin #	Dir	Description
XTALIN	95	Input	Crystal Clock Input. Also allows LVTTTL input. Frequency required: 26-28.5 MHz
XTALOUT	94	Output	Crystal Clock Output.
MCLK	89	Output	Audio Master Clock Output.
SCK/DCLK	86	Output	I ² S Serial Clock Output. DSD Clock Out.
WS/DR0	85	Output	I ² S Word Select Output. DSD Serial Right Ch0 Data Output.
SD0/DL0	81	Output	I ² S Serial Data Output / DSD Audio Output.
SD1/DR1	82	Output	Configurable to be shared with DSD.
SD2/DL1	83	Output	SD0 = DSD Serial Left Ch0 Data Output.
SD3/DR2	84	Output	SD1 = DSD Serial Right Ch1 Data Output. SD2 = DSD Serial Left Ch1 Data Output. SD3 = DSD Serial Right Ch2 Data Output.
SPDIF/DL2	78	Output	S/PDIF Audio Output. Configurable to be shared with DSD. DSD Serial Left Ch2 Data Output.
MUTEOUT	75	Output	Mute Audio Output. Signal to the external downstream audio device, audio DAC, etc. to mute audio output.

Configuration / Programming Pins

Pin Name	Pin #	Dir	Description
INT	102	Output	Interrupt Output. Configurable polarity and pushpull output. Multiple sources of interrupt can be enabled through the INT_EN register.
RESET#	100	Input	Reset Pin. Active LOW. 5V Tolerant
DSCL0	34	Input	DDC I ² C Clock for Port 0. 5V Tolerant. HDCP KSV, An and Ri values are exchanged over an I ² C port during authentication. True open drain, so does not pull to GND if R0PWR5V is not applied.
DSDA0	33	Bi-Di	DDC I ² C Data for Port 0. 5V Tolerant. HDCP KSV, An and Ri values are exchanged over an I ² C during authentication. True open drain, so does not pull to GND if R0PWR5V is not applied.
DSCL1	29	Input	DDC I ² C Clock for Port 1. 5V Tolerant. 5V Tolerant. HDCP KSV, An and Ri values are exchanged over an I ² C port during authentication. True open drain, so does not pull to GND if R1PWR5V is not applied.
DSDA1	28	Bi-Di	DDC I ² C Data for Port 1. 5V Tolerant. 5V Tolerant. HDCP KSV, An and Ri values are exchanged over an I ² C port during authentication. True open drain, so does not pull to GND if R1PWR5V is not applied.
CSCL	27	Input	Configuration/Status I ² C Clock. 5V Tolerant. Chip configuration/status, CEA-861 support and downstream HDCP repeater-specific registers are accessed via this I ² C port. True open drain, so does not pull to GND if power is not applied.
CSDA	26	Bi-Di	Configuration/Status I ² C Data. 5V Tolerant. Chip configuration/status, CEA-861 support and downstream HDCP repeater-specific registers are accessed via this I ² C port. True open drain, so does not pull to GND if power is not applied.
CI2CA	105	Input	Local I ² C Address Select. 5V Tolerant. Low = Addresses 0x60/0x68 High = Addresses 0x62/0x6A
SCDT	101	Output	Indicates Active Video at HDMI Input Port. Sync detection indicator.
R0PWR5V	35	Input	Port 0 Transmitter Detect. 5V Tolerant. Used for MUTEIN function.
R1PWR5V	30	Input	Port 1 Transmitter Detect. 5V Tolerant. Used for MUTEIN function.
RSVDNC	98, 77, 76, 55	---	Reserved, must be left unconnected
RSVDL	99	Input	Reserved, must be tied to ground

IC BLOCK DIAGRAMS AND TERMINAL DESCRIPTIONS-43

Q8501 : SiI9135ACTU (HDMI Receiver)-5/5

TERMINAL DESCRIPTION

Differential Signal Data Pins

Pin Name	Pin #	Dir	Description	
R0XC+	40	Input	TMDS Input Clock Pair	HDMI Port 0
R0XC-	39	Input		
R0X0+	44	Input	TMDS Input Data Pair	
R0X0-	43	Input		
R0X1+	48	Input	TMDS Input Data Pair	
R0X1-	47	Input		
R0X2+	52	Input	TMDS Input Data Pair	
R0X2-	51	Input		
R1XC+	58	Input	TMDS Input Clock Pair	HDMI Port 1
R1XC-	57	Input		
R1X0+	62	Input	TMDS Input Data Pair	
R1X0-	61	Input		
R1X1+	66	Input	TMDS Input Data Pair	
R1X1-	65	Input		
R1X2+	70	Input	TMDS Input Data Pair	
R1X2-	69	Input		

Power and Ground Pins

Pin Name	Pin #	Type	Description
CVCC18	12, 24, 25, 80, 91, 107, 119, 131, 143	Power	Digital Logic VCC.
CGND	11, 23, 79, 90, 106, 118, 130, 142	Ground	Digital Logic GND.
IOVCC33	6, 18, 32, 74, 88, 104, 113, 125, 137	Power	Input/Output Pin VCC.
IOGND	4, 17, 31, 73, 87, 103, 112, 124, 136	Ground	Input/Output Pin GND.
AVCC33	38, 42, 46, 50, 56, 60, 64, 68	Power	TMDS Analog VCC 3.3V.
AGND	36, 41, 45, 49, 53, 59, 63, 67, 71	Ground	TMDS Analog GND.
AVCC18	37, 54, 72	Power	TMDS Analog VCC 1.8V.
DVCC18	92	Power	Audio Clock Regeneration PLL. Analog VCC. Must be connected to 1.8V.
DGND	93	Ground	Audio Clock Regeneration PLL. Analog Ground.
XTALVCC	96	Power	Audio Clock Regeneration PLL Crystal Oscillator Power. Must be connected to 3.3V.
REGVCC	97	Power	Audio Clock Regeneration PLL. Crystal Regulator Power. Must be connected to 3.3V.

FL TUBE

Q7002 : 16-BT-138GNK

GRID ASSIGNMENT

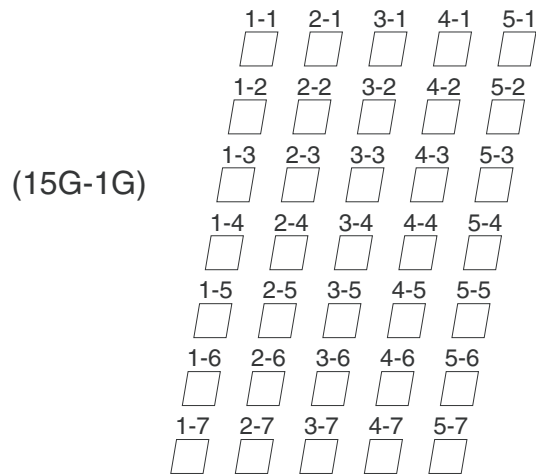
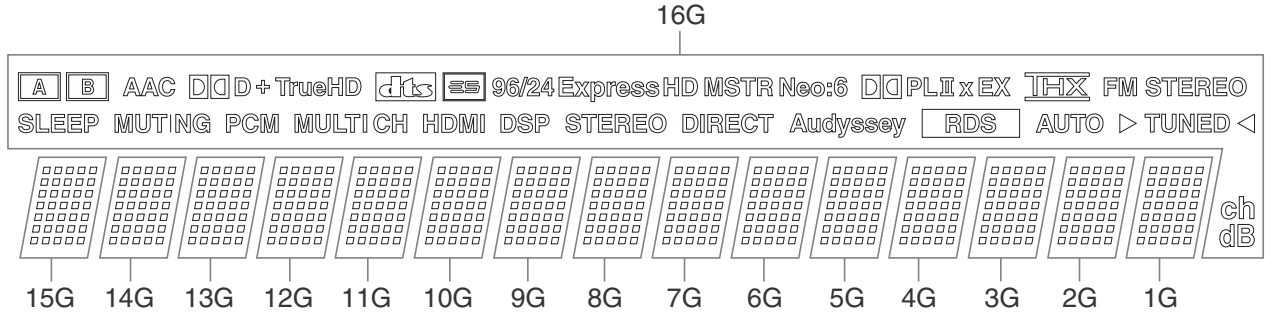

ANODE CONNECTION

	16G	15G-1G
P1	SLEEP	1-1
P2	MUTING	2-1
P3	PCM	3-1
P4	MULTI CH	4-1
P5	HDMI	5-1
P6	DSP	1-2
P7	(DPS) STEREO	2-2
P8	DIRECT	3-2
P9	Audyssey	4-2
P10	RDS	5-2
P11	AUTO	1-3
P12	▷ (TUNED) ◁	2-3
P13	TUNED	3-3
P14	A	4-3
P15	B	5-3
P16	AAC	1-4
P17	(AAC) D	2-4
P18	D	3-4
P19	+	4-4
P20	TrueHD	5-4

	16G	15G-1G
P21	DTS	1-5
P22	ES	2-5
P23	96/24	3-5
P24	Express	4-5
P25	HD	5-5
P26	MSTR	1-6
P27	Neo:6	2-6
P28	(Neo:6) DI	3-6
P29	PLI	4-6
P30	X	5-6
P31	EX	1-7
P32	THX	2-7
P33	FM STEREO	3-7
P34	ch	4-7
P35	dB	5-7

MICROPROCESSOR TERMINAL DESCRIPTIONS-1

Q701 : MPD70F3746 (Main Microprocessor)

Pin No.	Pin Name	I/O	Act.	Description
1	AVREF	---	---	Power supply. (A/D reference)
2	AVSS	---	---	Ground.
3	FANCTRL	---	---	Not used.
4	VDLOCK	I	H	INT signal input from Video signal processor (FLI30502).
5	AVREF	---	---	Power supply. (D/A reference)
6	VSPREQ	I	H	Video signal processor (FLI30502) handshaking 1.
7	FLMD00	O	H	Self writing select signal output.
8	FLMD0	I	H	Self writing select signal input.
9	VDD	---	---	Power supply.
10	REGC	---	---	Connect to capacitor for internal regulator.
11	VSS	---	---	Ground.
12	XIN	I	---	Connected to oscillator.
13	XOUT	O	---	Connected to oscillator.
14	RESET	I	L	Reset input.
15	XT1	---	---	Not used.
16	XT2	---	---	Not used.
17	VSPRDY	I	H	Video signal processor (FLI30502) handshaking 2.
18	POFF	I	L	Power failure detection input.
19	REMIN	I	L	Remote control signal input.
20	DRST	I	L	On chip debugger reset signal input.
21	DOCKDET/ECONRESET	---	---	Not used.
22	VSPSDA	I/O	H	Video signal processor (FLI30502) I2C data input/ output.
23	VSPSCL	O	CLK	Video signal processor (FLI30502) I2C clock output.
24	VSPRST	O	L	Video signal processor (FLI30502) reset control.
25	RS232TXD	---	---	Not used.
26	RS232RXD	---	---	Not used.
27	XMLNK	---	---	Not used.
28	XMANT	---	---	Not used.
29	XMSRRST	---	---	Not used.
30	DSPINT1	O	L	DSP IC (D788E001) AD detection signal output.
31	XMSRSEL	---	---	Not used.
32	HPD_RX1	O	H	HDMI IN 1 hot plug/ DDC(display data channel) line protect signal output.
33	VSS	---	---	Ground.
34	VDD	---	---	Power supply.
35	DOCKTXD/ECONTXD	---	---	Not used.
36	DOCKRXD/ECONRXD	---	---	Not used.
37	KEYINT0	I	CLK	Key input 0.
38	KEYINT1	I	CLK	Key input 1.
39	OC_DDI	I	H	On chip debugger data input.
40	OC_DDO	O	H	On chip debugger data output.
41	OC_DCK	I	CLK	On chip debugger clock input.
42	OC_DMS	I	H	On chip debugger transfer mode select input.
43	SDA_RXEDID1	I/O	H	HDMI IN EEPROM I2C data input/ output.
44	SCL_RXEDID1	O	CLK	HDMI IN EEPROM I2C clock output.
45	POWER_RX1	I	H	HDMI IN +5V power detection.
46	SDA_RX	I/O	H	HDMI switch IC (SiI9185) I2C control I2C serial data input/ output.
47	SCL_RX	O	CLK	HDMI switch IC (SiI9185) I2C control I2C serial clock output.
48	INT_RX	I	L	HDMI receiver IC (SiI9135) INT signal input.
49	DIGSDI	I	H	DIR/ CODEC (CS42518)/ DSP (D788E001) data input.
50	DIGSDO	O	H	DIR/ CODEC (CS42518)/ DSP (D788E001) data output.

MICROPROCESSOR TERMINAL DESCRIPTIONS-2

Q701 : MPD70F3746 (Main Microprocessor)

Pin No.	Pin Name	I/O	Act.	Description
51	DSPCLK	O	CLK	DSP IC (D788E001) clock output.
52	MUTE_RX	I	H	HDMI receiver IC (SiI9135) RXMUTE signal input.
53	RST_RX	O	L	HDMI switch IC (SiI9185) reset signal output.
54	CECOUT	O	L	CEC (consumer electronic control) signal output.
55	CECIN	I	L	CEC (consumer electronic control) signal input.
56	SCL_TX	O	CLK	HDMI transmitter IC (SiI9134) control I2C serial clock output.
57	SDA_TX	I/O	H	HDMI transmitter IC (SiI9134) control I2C serial data input/ output
58	NU	---	---	Not used.
59	XMSRRXD	---	---	Not used.
60	XMSRTXD	---	---	Not used.
61	SDA_TXDDC	I/O	H	TX side DDC/ EDID (extended display identification data) serial data input /output.
62	SCL_TXDDC	O	CLK	TX side DDC/ EDID (extended display identification data) serial clock output.
63	HPD_TX	I	H	TX side hot plug detection signal input.
64	INT_TX	I	L	HDMI transmitter IC (SiI9134) INT signal input.
65	RST_TX	O	L	HDMI transmitter IC (SiI9134) reset signal output.
66	SYROUT	O	L	RI (system control) output.
67	PLLSCL	O	CLK	Tuner unit I2C clock output.
68	PLLSDA	I/O	H	Tuner unit I2C data input/ output.
69	FLSDO	O	H	FL driver IC (M66005) data output.
70	FLDCLK	O	CLK	FL driver IC (M66005) clock output.
71	FSI	I	H	Flash microprocessor writing serial data input.
72	FSO	O	H	Flash microprocessor writing serial data output.
73	FCLK	I	CLK	Flash microprocessor writing serial clock output.
74	SYSIN	I	H	RI (system control) input.
75	RDSCLK	I	CLK	MPP type : RDS clock input. Other type : Not used.
76	POFF2	I	L	Power failure detect input-2.
77	FLDRST	O	L	FL driver IC (M66005) reset output.
78	FLDCS	O	L	FL driver IC (M66005) chip select output.
79	SD	I	H	FM/AM receive detection.
80	STEREO	I	L	FM stereo signal detection.
81	DSPINT2	I	L	DSP IC (D788E001) AD detection input.
82	DSPINT0	I	L	DSP IC (D788E001) AD detection input.
83	DSPCS	O	L	DSP IC (D788E001) chip select output.
84	XMDACRST	---	---	Not used.
85	HS	O	H	Handshaking signal output for flash microprocessor writing.
86	DSRST	O	L	DSP AD reset control output.
87	DIRINT0	I	H	DIR/ CODEC IC (CS42518) unlock detection input.
88	DIRCLK	O	CLK	DIR/ CODEC IC (CS42518) clock output.
89	DIRCS	O	L	DIR/ CODEC IC (CS42518) chip select output.
90	DIRRST	O	L	DIR/ CODEC IC (CS42518) reset output.
91	INPSEL	O	H	TX input signal select control output.
92	DSPINPSEL	O	H	DSP input signal select control output.
93	RDSDATA	I	H	MPP type : Tuner unit RDS data input. Other type : Not used.
94	VMUT	O	H	Video muting control output.
95	VSW_S1	O	H/L	Video switch IC (AN15880A) control.
96	VSW_S2	O	H/L	Video switch IC (AN15880A) control.
97	VSW_S3	O	H/L	Video switch IC (AN15880A) control.
98	VSW_S4	O	H/L	Video switch IC (AN15880A) control.
99	VSW_S5	O	H/L	Video switch IC (AN15880A) control.
100	VSW_S6	O	H/L	Video switch IC (AN15880A) control.

MICROPROCESSOR TERMINAL DESCRIPTIONS-3

Q701 : MPD70F3746 (Main Microprocessor)

Pin No.	Pin Name	I/O	Act.	Description
101	VSW_S7	O	H/L	Video switch IC (AN15880A) control.
102	VSW_S8	O	H/L	Video switch IC (AN15880A) control.
103	VSS	---	---	Ground.
104	VCC2	---	---	Power supply.
105	SBZ2MUT	O	H	Surround back/ Zone 2 muting control.
106	PRRLF	O	H	Preout (front L/R) relay control.
107	Z2MUT	O	H	Zone 2 muting control.
108	AMUT	O	H	Audio muting control.
109	PROTECT	I	H	Speaker protect detection.
110	ROMCS	O	H	EEPROM IC (R1EX25064) chip select.
111	ROMCLK	O	CLK	EEPROM IC (R1EX25064) clock output.
112	ROMSDI	I	H	EEPROM IC (R1EX25064) data input.
113	ROMSDO	O	H	EEPROM IC (R1EX25064) data output.
114	SPRLF	O	H	Front speaker relay control.
115	SPRLCS	O	H	Center/ surround speaker relay control.
116	SPRLSB	O	H	Surround back speaker relay control.
117	PRERLSB	O	H	Speaker-B relay control.
118	SPRLZ2	O	H	Zone 2 speaker relay control.
119	SEC1H	O	H	Secondary-1 (high) power supply control.
120	VOLCLK	O	CLK	Volume/ selector IC (R2S15211) clock output.
121	VOLDATA	O	H	Volume/ selector IC (R2S15211) data output.
122	Z2VOLCLK	O	H	Zone 2 output volume IC clock output..
123	APOWER	O	H	Main power supply control.
124	VPOWER	O	H	Video circuit power supply control.
125	HPDET	I	H	Headphone detection input.
126	MICMUT	O	H	Setup mic muting output.
127	MICDET	I	L	Setup mic detection input.
128	LEDZONE2	O	H	Zone 2 LED control output.
129	LEDSTBY	O	L	Standby LED control output.
130	TRGC	---	---	Not used.
131	TRGB	---	---	Not used.
132	TRGA	---	---	Not used.
133	VOLA	I	CLK	Rotary encoder (Master volume) signal input.
134	VOLB	I	CLK	Rotary encoder (Master volume) signal input.
135	VOLH	I	AD	Power amplifier output voltage detection.
136	THERMAL	I	AD	Thermal detection.
137	INIT3	I	AD	Initial setting.
138	INIT2	I	AD	Initial setting.
139	INIT1	I	AD	Initial setting.
140	BAND	I	AD	Initial setting.
141	KEY3	I	AD	key input.
142	KEY2	I	AD	key input.
143	KEY1	I	AD	key input.
144	KEY0	I	AD	key input.

SERVICE PROCEDURE-1

1. Replacing the fuses

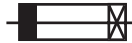
 This symbol located near the fuse indicates that the fuse used is slow operating type. For continued protection against fire hazard, replace with same type fuse. For fuse rating, refer to the marking adjacent to the symbol.

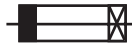
 Ce symbole indique que le fusible utilise est e lent. Pour une protection permanente, n'utiliser que des fusibles de meme type. Ce demier est indique la qu le present symbol est apposre.

REF NO.	PART NAME	DESCRIPTION	PART NO.	REMARKS
F901	FUSE	8A-UL/T-233	252329GR	!<MDC>
F901 or	FUSE	8A-T/UL-ST2	252261GR	!<MDC>
F901	FUSE	4A-SE-EAK	252077GR	!<MPP>
F901 or	FUSE	4A-SE-TL250V	252277GR	!<MPP>
F6901	FUSE	10A-UL/T-233	252330GR	!
F6901 or	FUSE	10A-T/UL-ST2	252333GR	!
F6902	FUSE	10A-UL/T-233	252330GR	!
F6902 or	FUSE	10A-T/UL-ST2	252333GR	!

<Notes>

<MDC> : Canadian model

<MPP> : European model

2. Safety check out

(U.S.A. model only)

After correcting the original service problem, perform the following safety check before releasing the unit to the customer.

Leakage current Check

Measure the leakage current to a known earth ground (water pipe or conduct etc.) by connecting a leakage current tester between the earth ground and exposed metal parts of the unit (input/output ground terminals, screw heads or metal overlays etc.).

Plug the power supply cord directly into a 120Vac 60Hz wall socket and turn ON/STANDBY button on.

Any current measured must not exceed 0.5mA.

3. Memory Backup

This model uses a EE-PROM IC in order to retain radio presets and other settings. So, memory contents will be kept eternally with no care.

4. To initialize the unit

1. Press and hold down VCR/DVR button, then press ON/STANDBY button when the unit is powered on.
2. After " *Clear* " is displayed, the preset memory and each mode stored in the memory, are initialized and will return to the factory settings.

SERVICE PROCEDURE-2

5. To check version of Main microprocessor, DSP and Video FW

1. Press and hold down DISPLAY button, then press ON/STANDBY button when the unit is power on.
The main microprocessor version will be displayed on Front Display for about 3 seconds.

Ex. Main1.00/08701A

2. Press + (TONE) button while the version is displayed. Then, " DSPSR606:08611A " will be displayed.
In this way, as + (TONE) button is pressed while a version is displayed, the next information will be displayed.
If - (TONE) button is pressed, the order will be reversed.

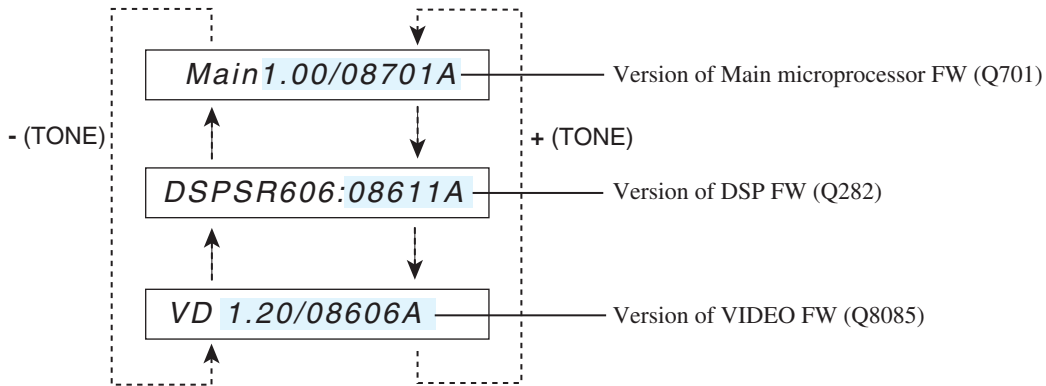

3. Press ON/STANDBY button to power off.

6. Replacing Power Amplifier Parts

When a power amplifier of certain channel is broken and goes into Protect mode, the following parts in the channel must be replaced at the same time, because these parts get damage in most cases.

Front		Center	Surround		Surround Back	
L ch	R ch		L ch	R ch	L ch	R ch
Q6001, 6011	Q6002, 6012	Q6000, 6010	Q6003, 6013	Q6004, 6014	Q6005, 6015	Q6006, 6016
Q6031, 6041	Q6032, 6042	Q6030, 6040	Q6033, 6043	Q6034, 6044	Q6035, 6045	Q6036, 6046
Q6051, 6061	Q6052, 6062	Q6050, 6060	Q6053, 6063	Q6054, 6064	Q6055, 6065	Q6056, 6066
C5051, 6041	C5052, 6042	C5050, 6040	C5053, 6043	C5054, 6044	C5055, 6045	C5056, 6046
R6021, 6071	R6022, 6072	R6020, 6070	R6023, 6073	R6024, 6074	R6025, 6075	R6026, 6076
R6081, 6091	R6082, 6092	R6080, 6090	R6083, 6093	R6084, 6094	R6085, 6095	R6086, 6096
R6101	R6102	R6100	R6103	R6104	R6105	R6106

Refer to "SCHEMATIC DIAGRAMS-2 (POWER AMPLIFIER SECTION)"

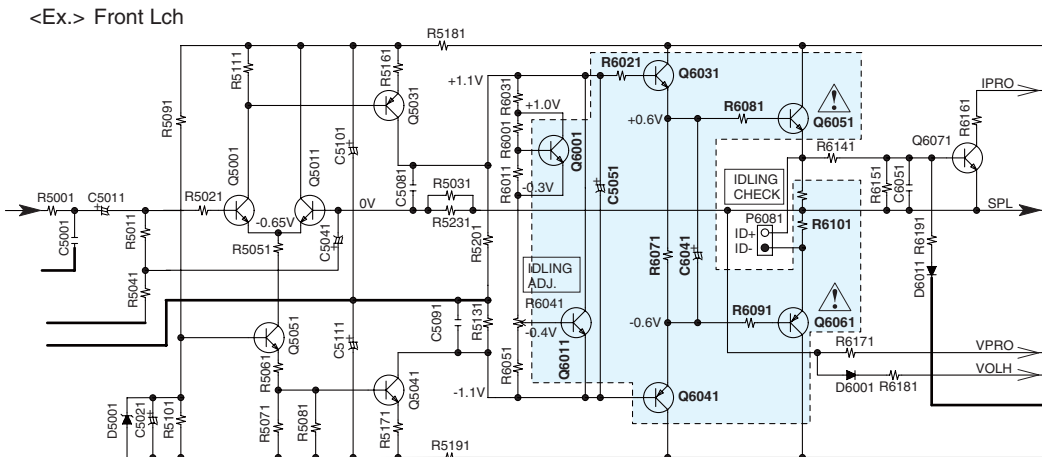

FIRMWARE UPDATE-1

GENERAL

To check version of Main Microprocessor, DSP and Video FW

1. Press and hold down **DISPLAY** button, then press **ON/STANDBY** button when the unit is power on.
The main microprocessor version will be displayed on Front Display for about 3 seconds.

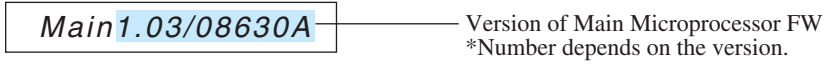

2. Press **+** (TONE) button while the version is displayed. Then, " *DSPSR606:08611A* " will be displayed.
In this way, as **+** (TONE) button is pressed while a version is displayed, the next information will be displayed.
If **-** (TONE) button is pressed, the order will be reversed.

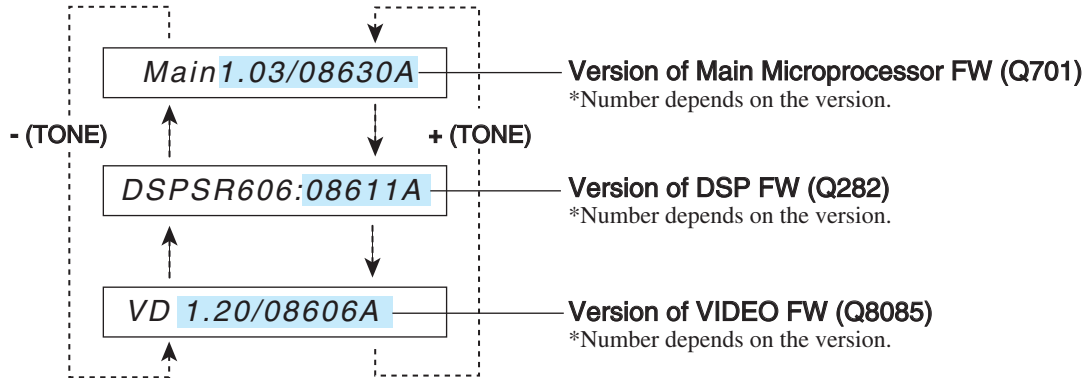

3. Press **ON/STANDBY** button to power off.

UPDATE OF MAIN MICROPROCESSOR-1/2

Preparation for update

Hardware tool

1. PC(Personal computer) with RS232 terminal
OS : Windows XP or 2000
2. Flashwriter jig : **OJFLASH** and **OJFLASHEX** (including 2 Types : for non-Main)

Software tool

- Writing soft : "**Update_SR606Main1.2.zip**" for Main microprocessor (File name depends on the version).
Unzip "Update_SR606Main1.2.zip" in advance.

Connection and setup

1. While the target unit is off, connect **OJFLASH** and **OJFLASHEX** (for non-Main) to RS232C port of the PC.
2. Connect the **FFC(Flat cable)** of the jig to the connector slot on the rear panel.
3. Power on the unit.

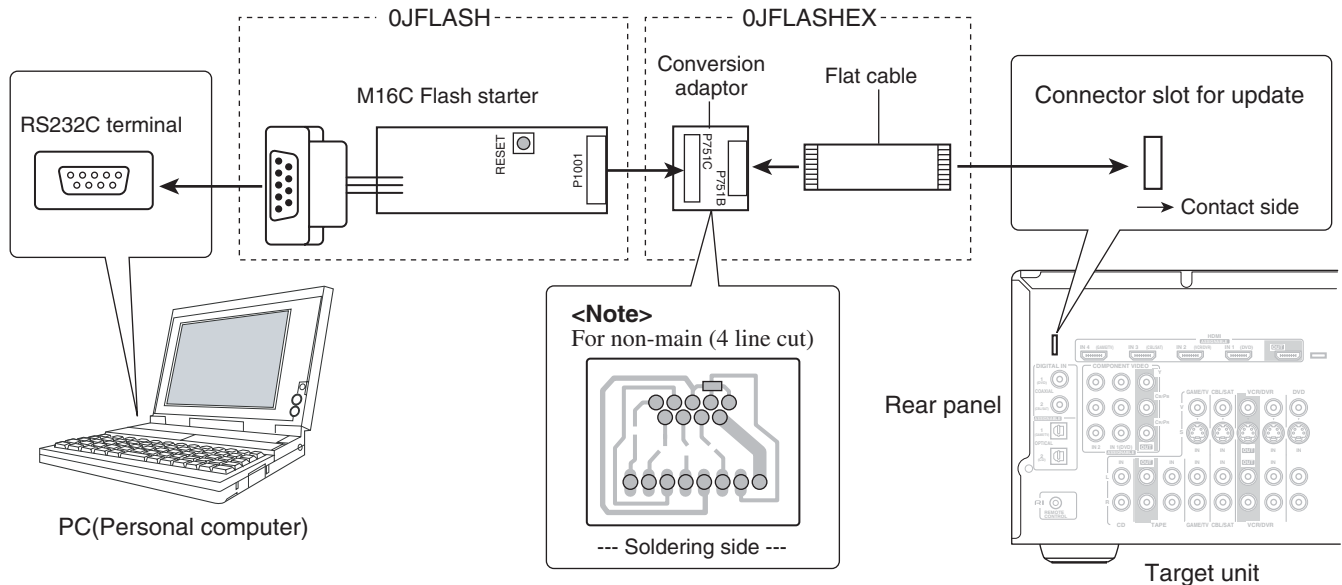

FIRMWARE UPDATE-2

UPDATE OF MAIN MICROPROCESSOR-2/2

Update Procedure

1. Double click "Update.exe" in the unzipped folder "Update_SR606Main1.2.zip" (Folder name depends on the version).
The following window will appear.

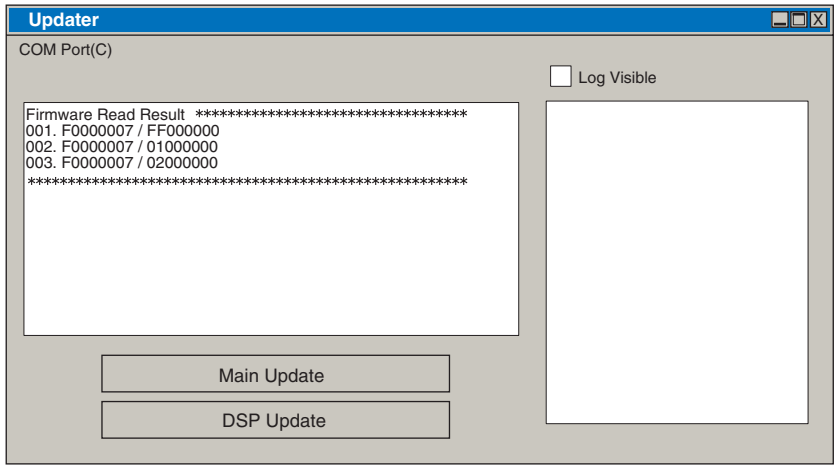

2. Click "Main Update" button. The update takes about 15 minutes.
The message on Front Display will change as follows

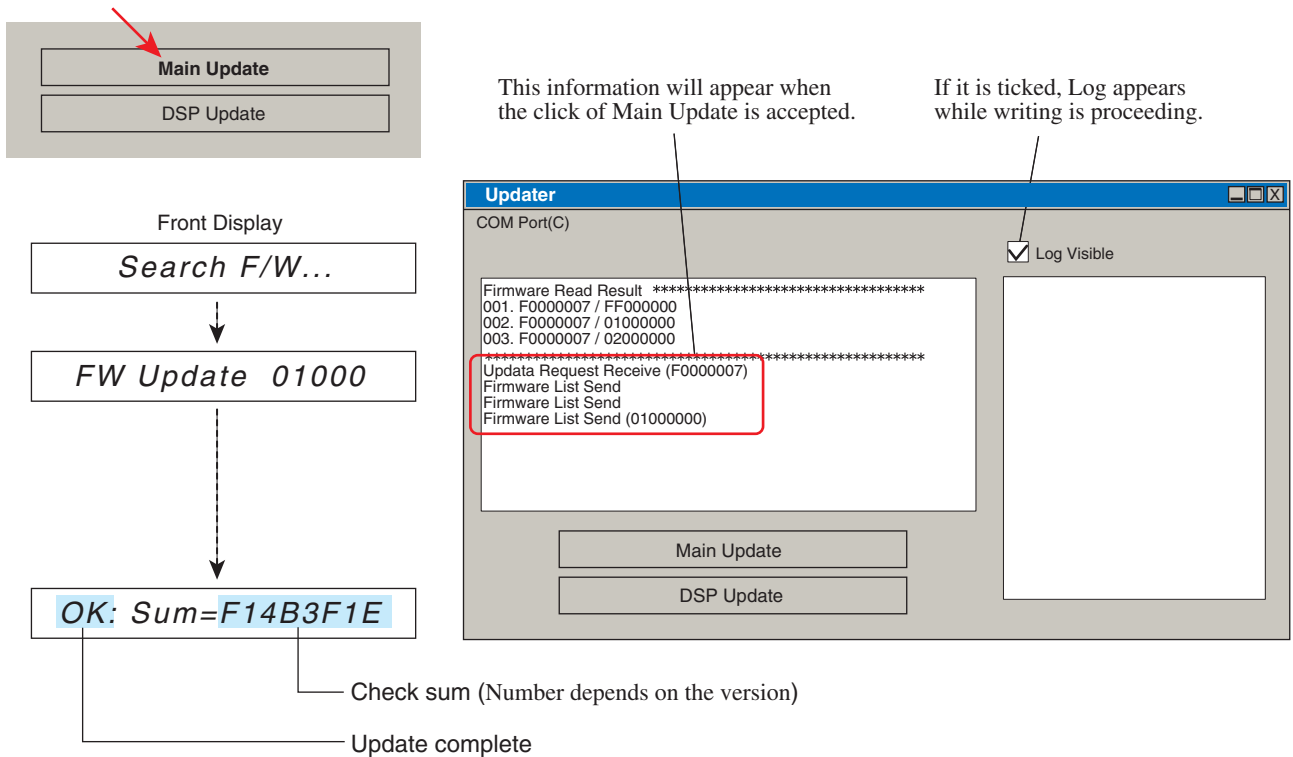

3. After the update ends, unplug the power code, remove the jig from the unit, and plug it again.
4. Turn on the unit and initialize it by holding down VCR/DVR and the pressing ON/STANDBY.
Confirm the new version number. Refer to "FIRMWARE UPDATE-1"

FIRMWARE UPDATE-3

UPDATE OF DSP

Preparation for update

Update is done by playback of CD-R in a CD player.

Tool

1. Blank CD-R : 1pc, PC (Personal computer with CD-R writer)
2. Writing soft : "CD_SR6060_08213A.wav" (File name depends on the version.)

<Note>

Store it in a blank CD-R as a music CD in advance. For a writing soft, contact Onkyo or your local distributor.

3. CD player with Optical or Coaxial output terminal.

<Note>

Some CD players and a lot of DVD players process audio signal before output. Such players cannot be used for this update.

4. Optical cable or Coaxial cable : 1pc.

Connection and setup

1. Connect a CD Player with the target unit via Optical Input 1 or Coaxial Input 1.
2. Power on the unit and wait for more than 10 seconds.

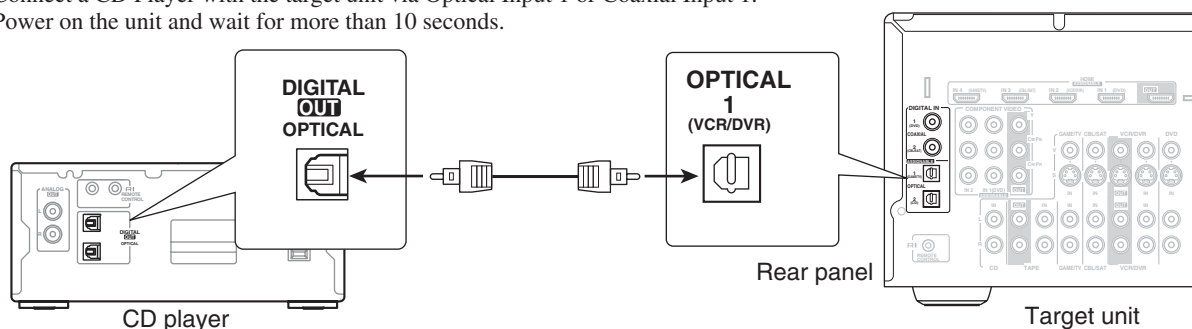

Update Procedure

1. Press and hold down **DISPLAY** button and then press **ON/STANDBY** button to show Main microprocessor FW version when the unit is powered on.

Main1.03/08630A — *Number depends on the version.

2. Press **+(TONE)** button twice while the Main microprocessor FW version is displayed for about 3 seconds. Then, DSP FW version will be displayed.

DSPSR606:08611A — *Number depends on the version.

3. Press **RETURN** button while the DSP version is displayed. Then, the following message will appear.

Digin: AUTO

4. Press **ENTER** button. Then, the following message will appear.

S/PDIF Update..

5. Play the DSP FW CD-R with the CD player. After playback finished, writing will start.

Writing...

<Note1>

If the above message does not appear after waiting for a while, please try again.

Some DVD players are not suitable for this update. If writing results in failure, use another model of player.

<Note2>

DURING WRITING, DO NOT TURN OFF THE POWER and DO NOT DISCONNECT OPTICAL/COAXIAL CABLE.

If writing is stopped in the middle, Flash IC may need replacing.

6. After writing ends, the message on Front Display will change as follows.

Clear



Standby mode

7. Confirm the new version number. refer to "FIRMWARE UPDATE-1".

FIRMWARE UPDATE-4

UPDATE OF VIDEO-1/6

Preparation for update

Hardware tool

1. PC(Personal computer) with RS232 terminal.
OS : Windows XP or 2000.
2. RS232 straight through cable.
3. Adaptor jig : **0JHUDSON**.

Software tool

GProbe 5[1].4.0.3.zip

Unzip it and install the software by clicking “GProbe54.0.3.exe” in advance referring to “FIRMWARE UPDATE-9”.

First Procedure

1. Store a provided folder “**Batch_File**” containing necessary folders and files in C drive.

C:\Batch_File

If there is “Batch_File” in C drive already, find a folder “Hudson2” in “Batch_File” and store the “Hudson2” in the “Batch_File”.

2. Make sure that the tree structure of the folder “**Batch_File**” is as shown below.

<Ex>

C:\Batch_File\Hudson2\16M	
Name ^	
<input type="checkbox"/> H2119_08419B_OSD08311B_ext.hex	Program file
<input type="checkbox"/> Hudson2_isp_spi_ext.hex	For communication
<input type="checkbox"/> Onkyo_H2119_08419B_OSD08311B_ext.hex.bat	Batch file

Connection and Setup

1. While the target unit is off, connect 0JHUDSON and RS232 cable to RS232 port of the PC.
2. Connect the FFC(Flat cable) of the jig to the connector slot on the rear panel.

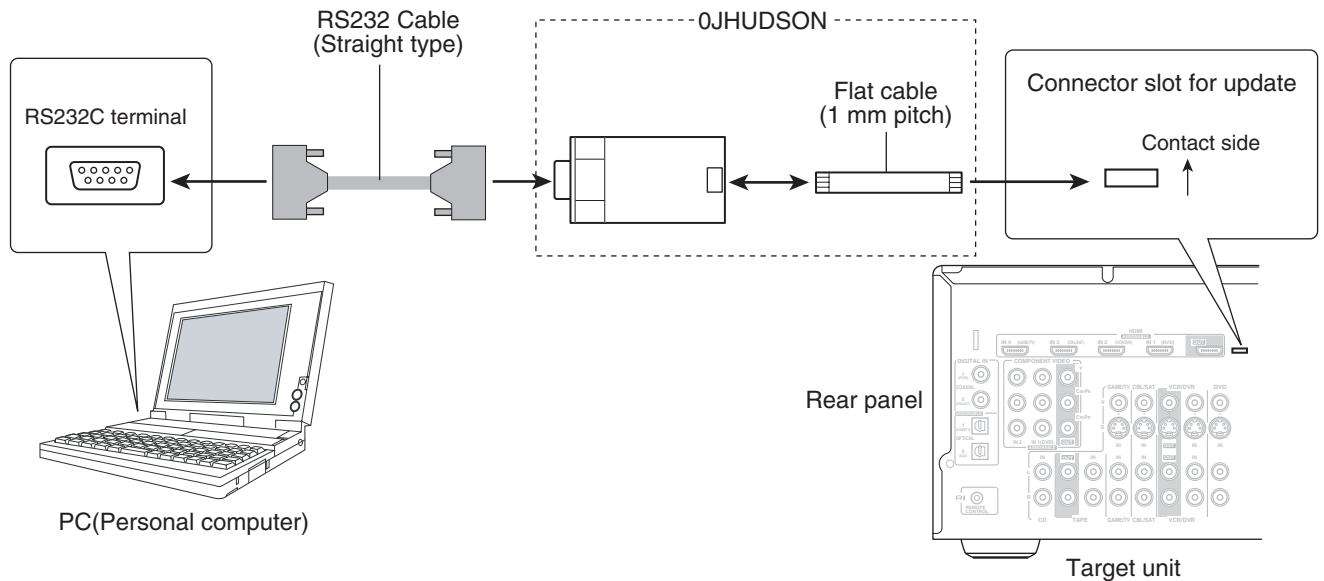

FIRMWARE UPDATE-5

UPDATE OF VIDEO-2/6

Update Procedure

1. Start GProbe by clicking the icon.



2. Turn on the unit and make sure that some information appears in the bottom right corner of the window. If nothing appears in this area, the PC does not communicate with the unit.

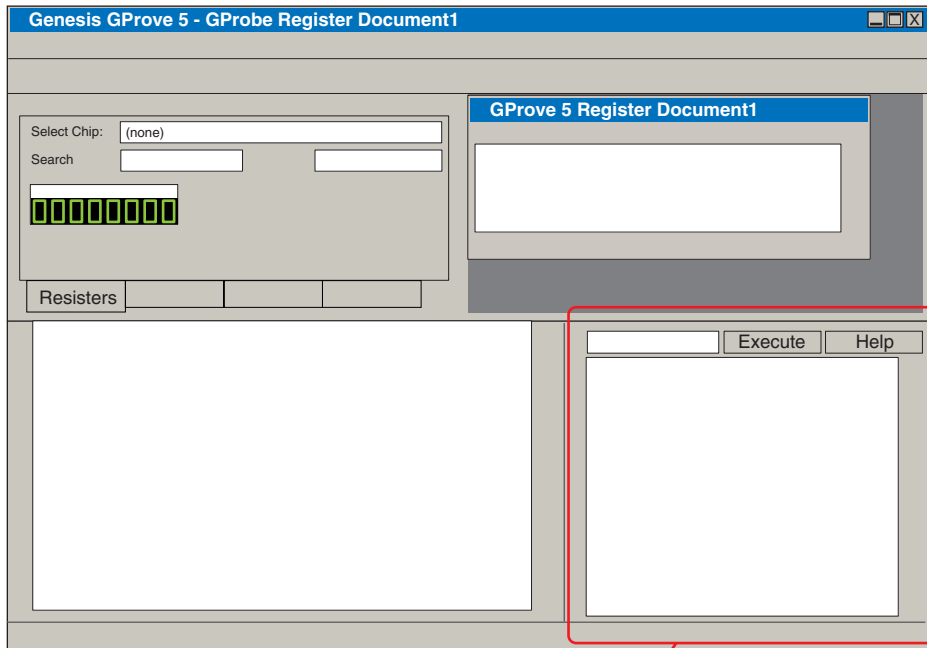

Wait until reading stops.

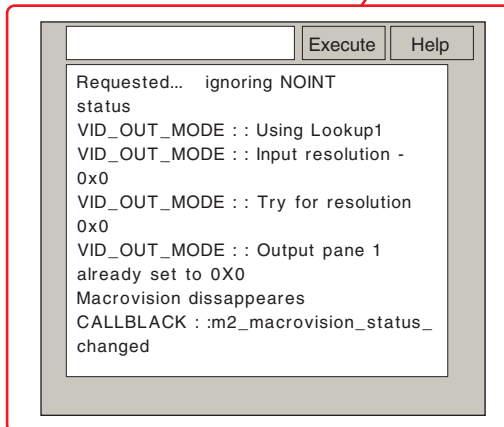

FIRMWARE UPDATE-6

UPDATE OF VIDEO-3/6

Troubleshooting

Communication error

Check the serial port setting by following ① and ②.

<Note>

Make sure that software applications installed after GProbe do not occupy the specified port.

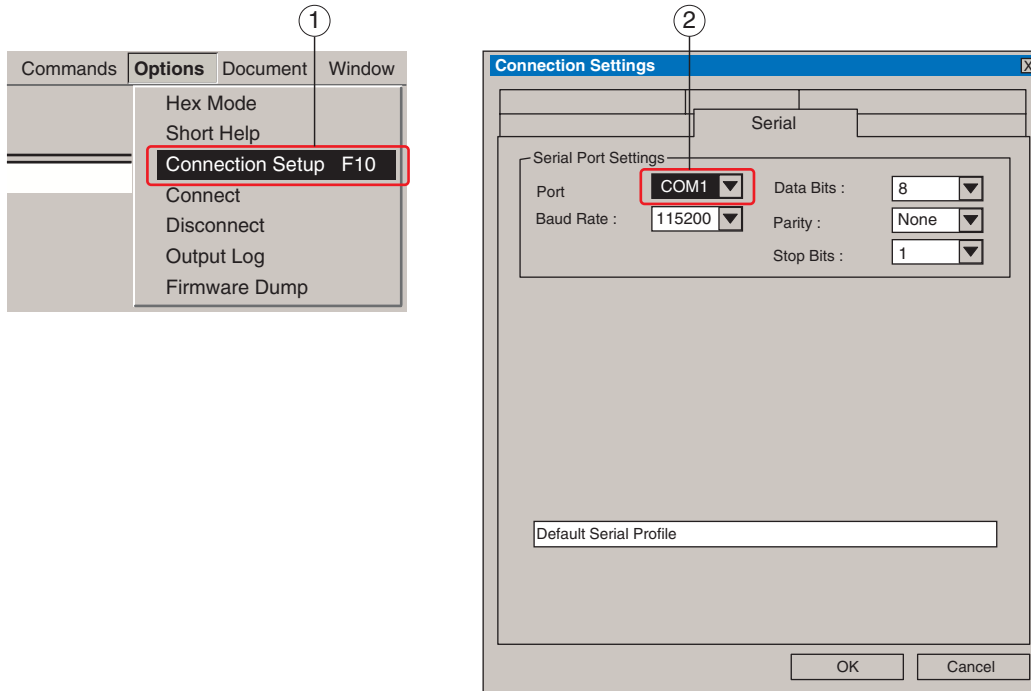

No reaction of Video processor

Start GProbe.

While temporarily short circuit Pin No. 6 and 7 of **Q8085** on NAHDM-9473, put the unit into Standby mode and then turn it on again.

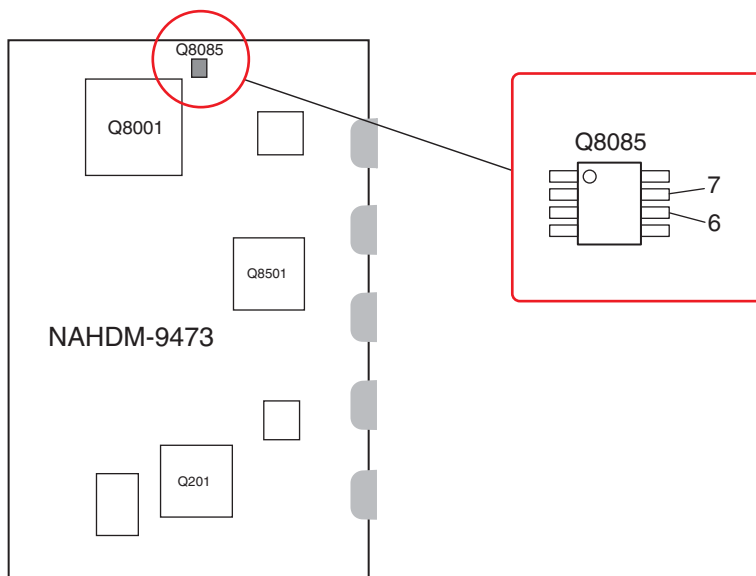

Make sure that Device name is shown as a message.

Go to **Step 3**.

FIRMWARE UPDATE-7

UPDATE OF VIDEO-4/6

Update Procedure (continue)

- Click “Commands” in the menu bar and select “Batch”

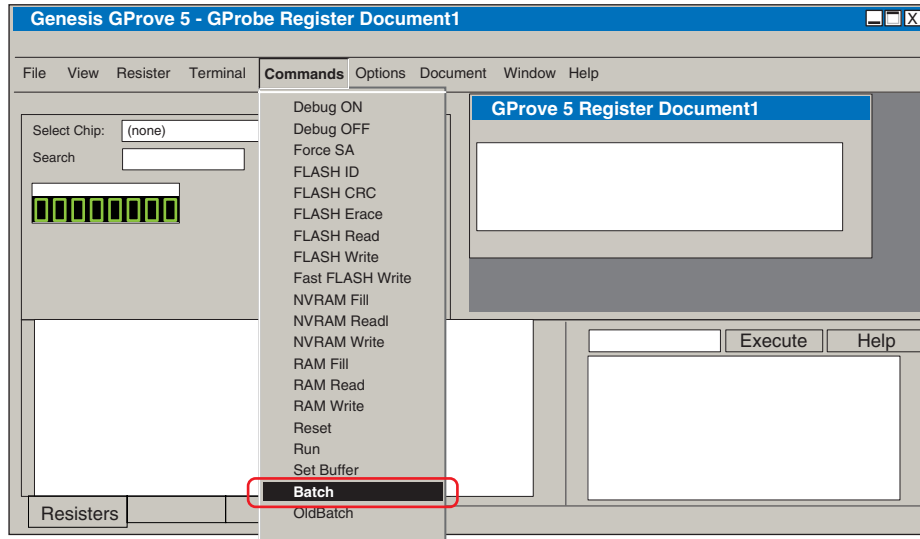

- Start Batch file by selecting the batch file, which has “.bat” as extension and is stored in First Procedure.

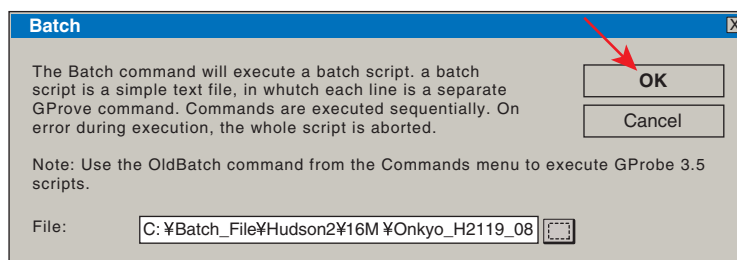
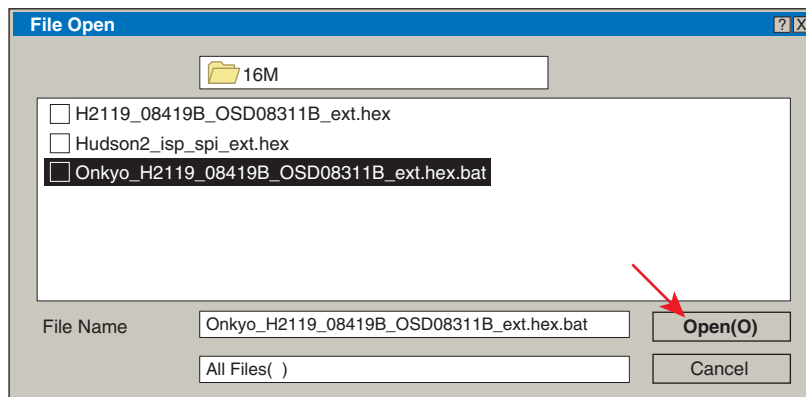
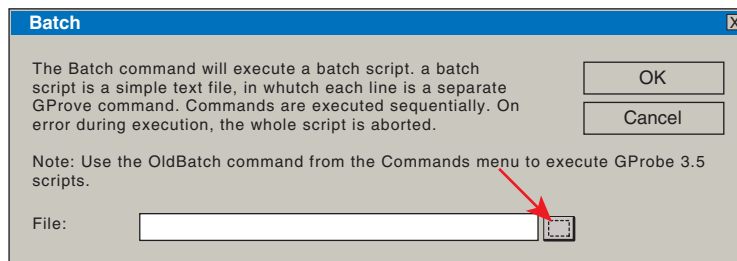

FIRMWARE UPDATE-8

UPDATE OF VIDEO-5/6

Update Procedure (continue)

5. Make sure that “**Command Successful. Writing FLASH...**” appears in the bottom right corner of the window.

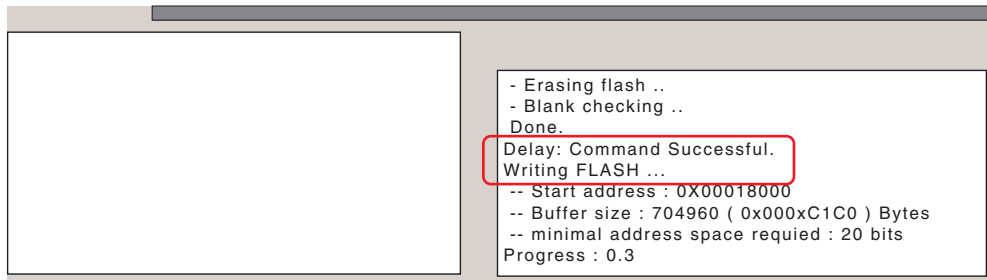

6. Make sure that “**Progress: 100.0 Command Successful**” is shown as below.

<Note>

Front Display on the unit will show no information about writing but continue to display what was shown before.

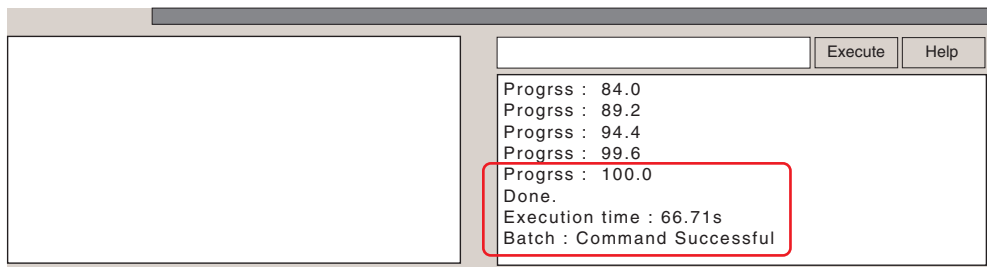

7. Turn off and on the unit.

8. Confirm the new version number. refer to “FIRMWARE UPDATE-1”.

If “**Command Successful Writing FLASH...**” does not appear, turn off and on the unit, and try again from **Step 1**.

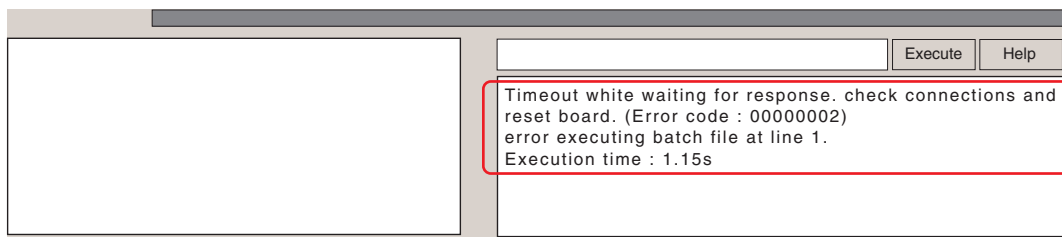

FIRMWARE UPDATE-9

UPDATE OF VIDEO-6/6

To install GProbe

1. Unzip "GProbe 5[1].4.0.3.zip" and click the extracted file "GProbe5.4.0.3.exe."

2. Follow the instructions on the window as below.

<Note>

Not all the windows are shown in this procedure.

①



②

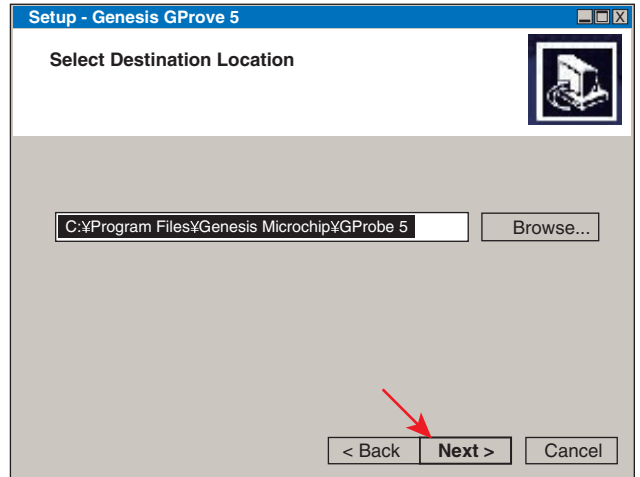

③

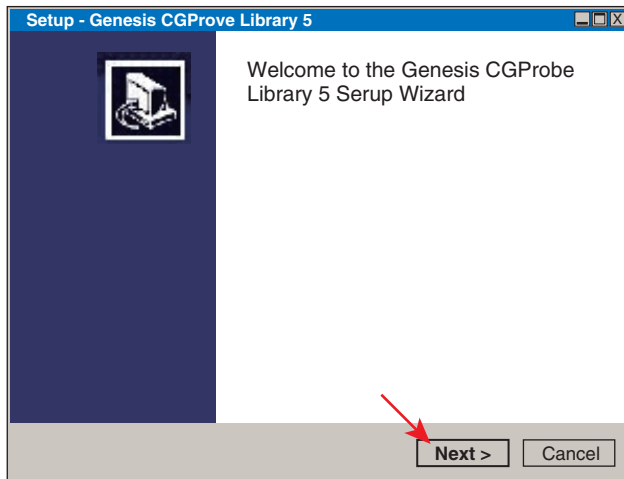

④

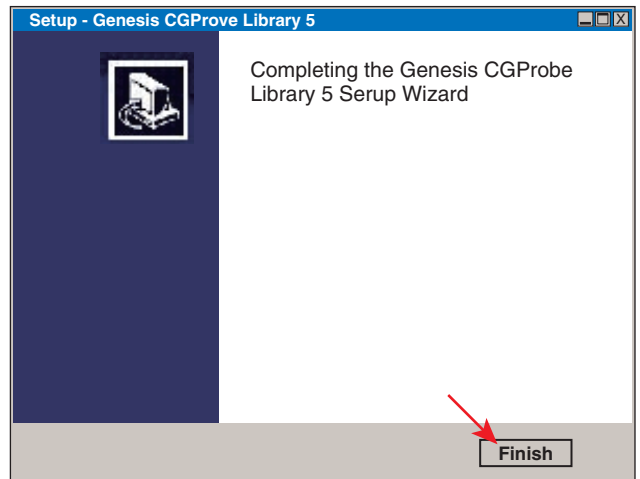

⑤

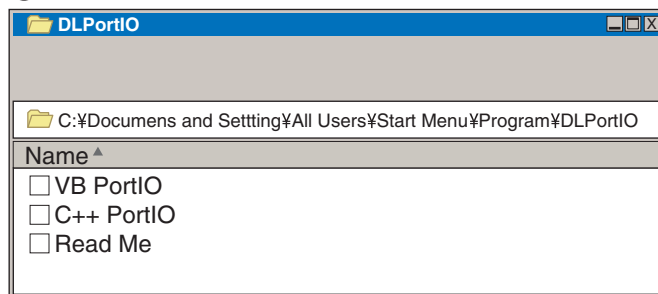

⑥

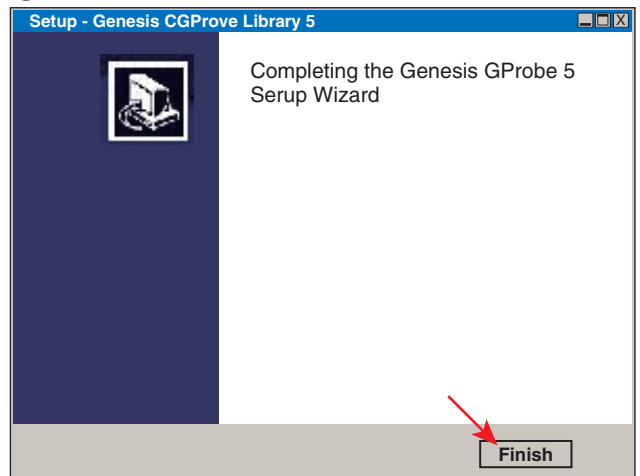

OPERATION CHECK-1

SPEAKER PROTECT-1

Circuit configuration

The unit go into protect mode when either of thermal detection, dc voltage detection or current detection circuit operates.

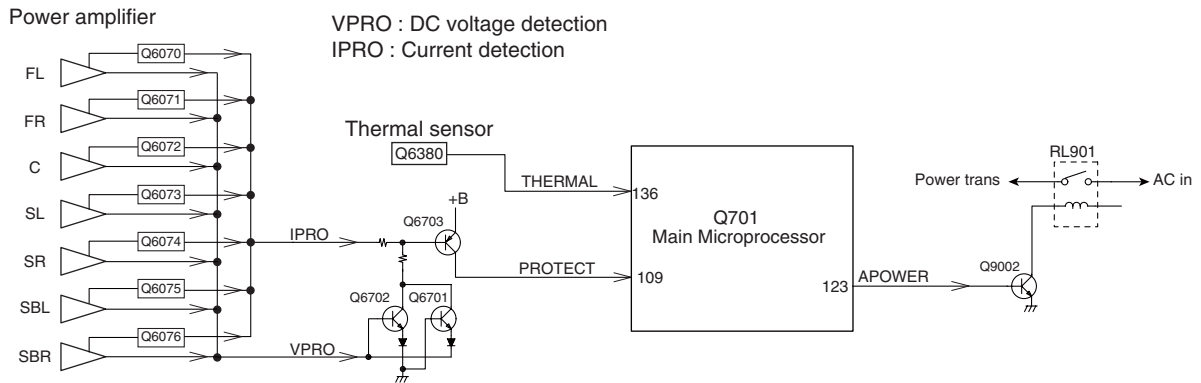

Condition to operate

The unit will go into the Protect mode under the following conditions.

1. Thermal condition

T (°C) Thermal sensor temperature	Protect
100 <	On (after 10 min.)
-30 >	On (immediately)
150 <	On (immediately)
90 < (40°C when power on)	On (immediately)
90 < (The unit powered on longer than 24 hours)	On (immediately)

2. DC voltage condition

The sum of dc voltage of 7 channel speaker outputs is more than 7 V.

3. Current condition

The ac current of speaker outputs is more than 35 A.

This condition is equivalent to TEST-4-35 in OPERATION CHECK-3.

Thermal detection check

[When]

Exchange thermal sensor PC board ass'y (NAETC-9426).

[Procedure]

- Press and hold down **DISPLAY** button, then press **ON/STANDBY** button when the unit is powered on. The microprocessor version will be displayed for 3 seconds.

FL Display
<Ex.> Ver. 1.02/08408A

- Press **TONE** button while the version is displayed.

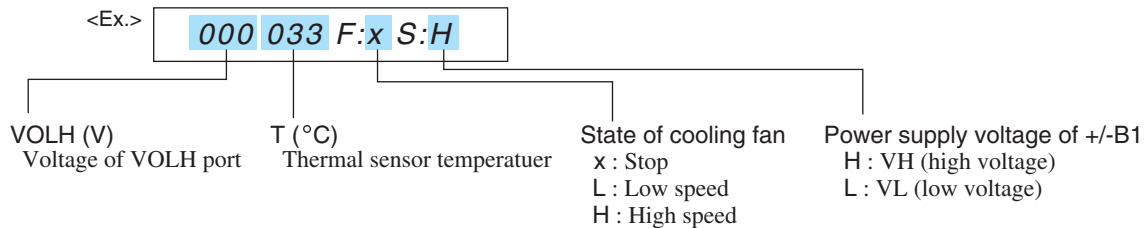

- Confirm that the displayed temperature is within +/-20 °C from the ambient temperature.

- Press **ON/STANDBY** button.



OPERATION CHECK-2

SPEAKER PROTECT-2

DC Voltage detection check

[When]

1. Exchange power transistors (Q6050 - Q6056, Q6060 - Q6066).
2. Exchange amplifier PC board ass'y (NAAF-9424).

[Procedure]

Note : No load. No input.

1. Press and hold down CD button, then press ON/STANDBY button while the unit is powered on.
" *Test - _* " is displayed only for 5 seconds.

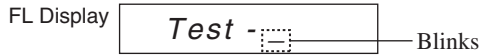

2. Press GAME/TV button while the characters of " *Test - _* " are displayed.
The unit will be in the state of " *Test-4-00* ".

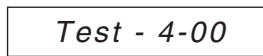

3. Repeatedly press + (TONE) button until the characters of " *Test-4-21* " are displayed.

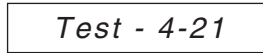

Check whether the operation starts and continues automatically as follows.

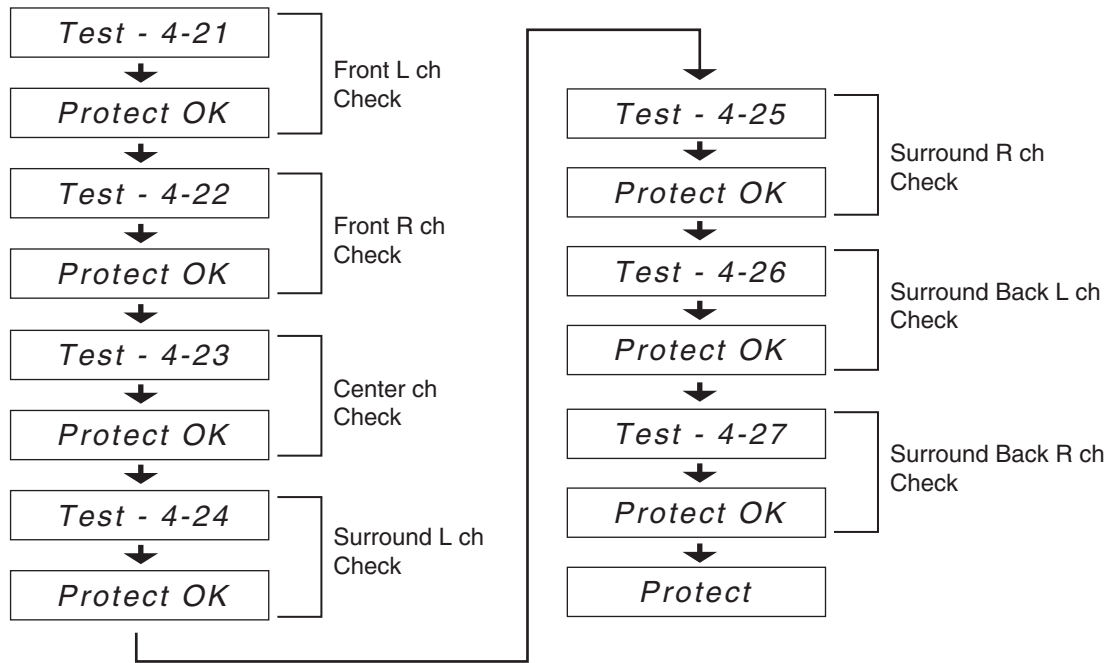

If all channels are OK, the characters of " *Test-4-35* " are displayed.

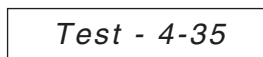

4. Press ON/STANDBY button.



OPERATION CHECK-3

SPEAKER PROTECT-3

Current detection check

[When]

1. Exchange power transistors (Q6050 - Q6056, Q6060 - Q6066).
2. Exchange amplifier PC board ass'y (NAAF-9424).

[Procedure]

Notes : No input.

Do not check two or more channels at the same time.

Do not connect a dummy load to speaker terminal longer than 2 seconds.

1. Press and hold down CD button, then press ON/STANDBY button while the unit is powered on.
" *Test - _* " is displayed for 5 seconds.

FL Display  Blinks

2. Press GAME/TV button, while " *Test - _* " is displayed.
The unit will be in the state of " *Test-4-00* ".



3. Repeatedly press + (TONE) button until " *Test-4-35* " is displayed.
The shape of wave form of <Fig-1> is output from the speaker terminal in this state.



4. Connect the dummy load of 3 ohms to the Front L ch speaker terminals.
At this time, confirm that the speaker relay is not turned off.



5. Connect the dummy load of 1 ohm to the Front L ch speaker terminals.
At this time, confirm that the speaker relay is turned off and " *Protect* " is displayed.



Disconnect the dummy load immediately after checking the display of " *Protect* ".



6. Check other channels according to the same procedure as 4 and 5.

7. Press the ON/STANDBY button.

 → 

<Fig-1>
Test wave form

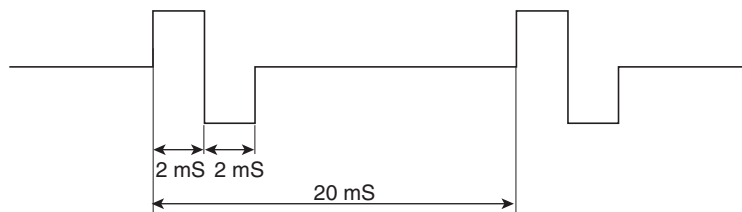

OPERATION CHECK-4 POWER SUPPLY CONTROL

Configuration

The power supply voltage of +/-B1 for power amplifier is changed by the relays (RL6901, 6902).

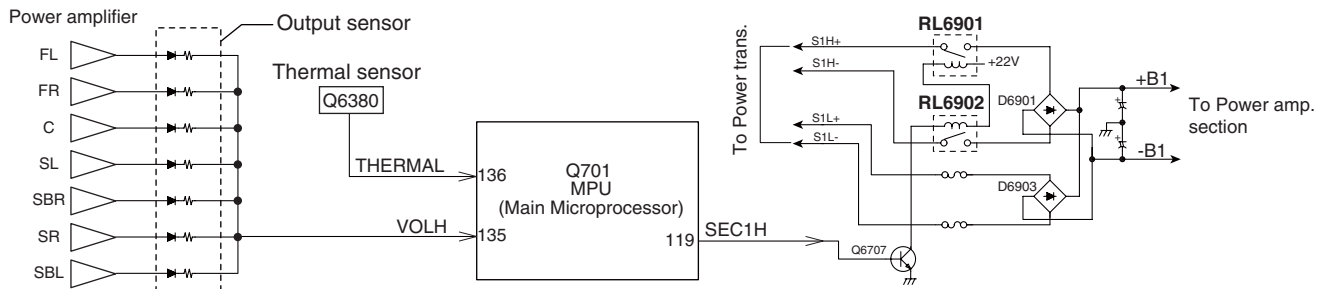

Condition to operate

The power supply voltage of +/-B1 under the following condition.

The state of "VOLH", "T", and "VH or VL" can be confirmed on the FL display. Refer to "OPERATION CHECK-1".

Operation of power supply control (VH or VL)

		VOLH (V) VOLH port of MPU		
		< 0.33	0.33 to 1.65 5 min.	1.65 < 5 sec.
T (°C) Thermal sensor temperature	< 60	VH	VL	VL
	60 <	VL	VL	VL

Operation of relay

	RL6901, 6902
VH : high voltage	ON
VL : low voltage	Off

Output sensor

[When]

Same as the Current detection check on "OPERATION CHECK-3".

[Procedure]

Notes : No output. No input.

- Press and hold down CD button, then press ON/STANDBY button while the unit is powered on.
" Test - _ " is displayed only for 5 seconds.

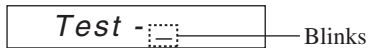

- Press GAME/TV button while " Test - _ " is displayed. The unit will be in the state of " Test-4-00 ".

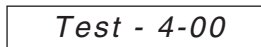

- Repeatedly press + (TONE) button until " Test-4-36 " is displayed.

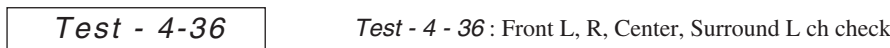

- At this time, confirm that the red characters of " FM STEREO " is displayed.
And, confirm that the relays RL6901 and RL6902 are turned off in 2 or 3 seconds.

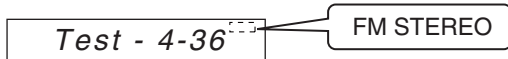

- Press + (TONE) button then " Test-4-37 " will be displayed.

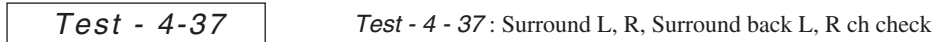

- At this time confirm that the red characters of " FM STEREO " is displayed.
And, confirm that the relays RL6901 and RL6902 are turned off in 2 or 3 seconds.

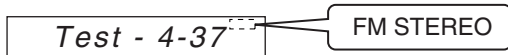

- Press ON/STANDBY button.



Thermal sensor

Same as the Thermal detection in "OPERATION CHECK-1".

OPERATION CHECK-5

COOLING FAN

Note : MWT, MWO, MWF type only

Circuit configuration

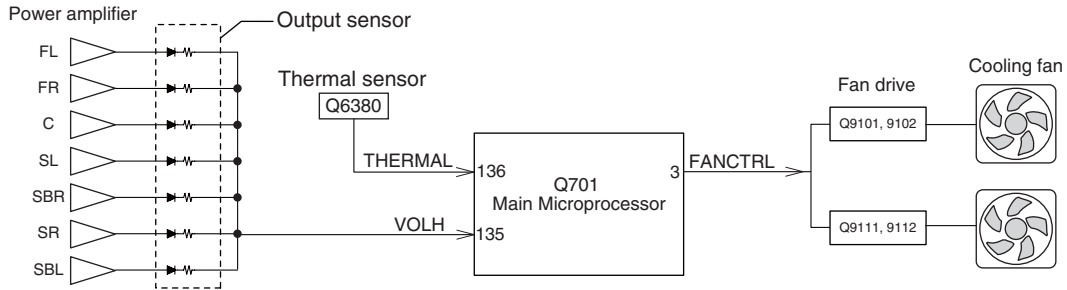

Condition to operate

The cooling fan will stop or rotate at high speed or low speed under the following condition.

Operation of Cooling Fan

		VOLH (V) VOLH port of MPU		
		0 to 0.35	0.35 to 1.75	1.75 to 3.3V
T (°C) Thermal sensor temperature	55 to 110	High Speed	High Speed	High Speed
	-30 to 55	Stop	Low Speed	High Speed

DEBUG MODE-1

DSP DEBUG MODE-1

The operations of DSP and DIR etc are able to checked by the information displayed on FL in this debug mode. This information will help to analysing digital audio no sound trouble.

To set in Debug mode

1. Press and hold down **DISPLAY** button, then press **ON/STANDBY** button while the unit is powered ON.
The version number of microprocessor is displayed only for 3 seconds.

Ver. 1.03/08630A

Version of Main Microprocessor FW
*Number depends on the version.

2. Press **+** (TONE) button within 3 seconds above, the version number of DSP will be displayed for 5 seconds.

DSPSR606:08611A

Version of DSP FW
*Number depends on the version.

3. Press **DISPLAY** button while the DSP version is displayed. The status of DSP and DIR etc will be displayed.

<Ex.>

E1A48K0N/OFFP0O

DSP debug mode

To exit

Press ON/STANDBY button.

Content of Display

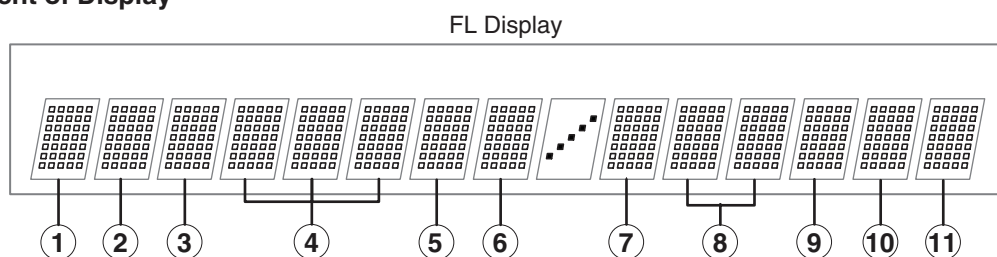

① DIR Input Lock/ Unlock

E = UNLOCK
= LOCK

② DIR Input RX

0 = None
1 = COAXIAL 1
2 = COAXIAL 2
3 = COAXIAL 3
4 = OPTICAL 1
5 = OPTICAL 2
6 = OPTICAL 3
7 = HDMI 1
8 = HDMI 2
9 = HDMI 3
A = HDMI 4
B = HDMI 5
C = HDMI 6
D = FRONT

③ DIR/ ADC Fix Mode

D = Digital(SPDIF)
A = Analog
M = Analog Multich
p = PCM Fixed
d = DTS Fixed

④ Sampling Frequency, Emphasis

32K = 32 kHz without Emphasis
44K = 44.1 kHz without Emphasis
48K = 48kHz without Emphasis
64K = 64 kHz
88K = 88.2 kHz
96K = 96 kHz
176 = 176.4 kHz
192 = 192 kHz
32e = 32 kHz with Emphasis
44e = 44.1 kHz with Emphasis
48e = 48 kHz with Emphasis

⑤ CODEC Clock Mode

N = Normal
U = Up Sampling
H = High Sampling (Double Rate)
D = Down Sampling
Q = Quad Rate

⑥ DIR Detect Type

0 = Analog
1 = PCM
2 = Not PCM
3 = Data
4 = DTS CD (Not used)
5 = Multich
6 = Not Decided

DEBUG MODE-2

DSP DEBUG MODE-2

Content of Display (Continued)

⑦ DSP Port

This figure is displayed in hexadecimal form.
If this is transformed to binary form, each bit indicates the following DSP port status. Refeo to <Fig-1>.

bit 0 = NIC (Normal state)
bit 1 = DEC
bit 2 = BUSY
bit 3 = Exec Wait (Abnormal state)

⑧ DSP Sequence

00 - FE = Boot
2D = Mute control
FF = Free

⑨ DSP Detect Format

P = PCM (Analog)
D = Dolby Digital
d = DTS
A = AAC
S = DSD
p = Dolby Digital+
T = True HD
H = DTSHD High Resolution
M = DTSHD Master Audio
? = Unknown

⑩ DSP Decode

o = Decode OK
x = Decode NG

⑪ Mute output device

This figure are displayed in hexadecimal form.
If these are transformed to binary form, each bit indicates the IC which outputs error and mute. Refeo to <Fig-1>.

bit 0 = Selector IC (Q5501)
bit 1 = Effector
bit 2 = DSP (Q201)
bit 3 = DIR (Q301)

<Fig-1>

Hexadecimal	Translation				Binary
0	0	0	0	0	0000
1	0	0	0	1	0001
2	0	0	1	0	0010
4	0	1	0	0	0100
8	1	0	0	0	1000

bit 0
bit 1
bit 2
bit 3

Trouble Shooting by DSP DEBUG MODE

1. This debug mode will be useful in digital audio no sound or sound drop-out trouble.
2. Check information on FL display, then identify bad parts, and replace or resolder it.
3. Remdies Written below are of typical case. So, more detailed check may need in actual cases.
4. Before replace ICs below, resolder the pins first to save resources.

<Note>

Function	Circuit No.	Schematic Diagrams
MPU (Main microprocessor)	Q701	SD-3
DSP	Q201	SD-7
DIR and DAC	Q301	SD-3
Flash ROM	Q282	SD-7
SDRAM	Q281	SD-7
Audio processor (Selector/ Volume)	Q5501	SD-1

Digit No. on FL	Symptom on FL display	Cause of trouble	Remedy
①	"E" is displayed	No input signal to DIR.	1. Find out which digital input does not work. 2. Confirm where the digital waveform stops between the digital input and DIR. 3. Resolder pins of the bad part or replace it with new one.
④	Displayed frequency is different from input signal.	No input signal to DIR.	The same as above.
⑥	Displayed audio format is different from input signal.	No input signal to DIR.	The same as above.

DEBUG MODE-3

DSP DEBUG MODE-3

Trouble Shooting by DSP DEBUG MODE (Continued)

Digit No. on FL	Symptom on FL display	Cause of trouble	Remedy
⑦	Continue to display "1"	Interface between DSP and MPU is no good.	The same remedy as ⑩-b.
	Continue to display "2"	Connection from DIR to DSP is no good.	The same remedy as ⑨.
	Continue to display "3" to "7"	Interface between DSP and MPU is no good.	The same remedy as ⑩-b.
	Continue to display "8" to "F"	DSP Sequence is no good.	Check ⑧ items.
⑧	Continue to display "03"	Communication between DSP and MPU is no good.	1. The same remedy as ⑩-b. 2. Check the voltage of the power supply pin of DSP. 3. Check the reset port and clock input of DSP by oscilloscope, and find out bad part. 4. Flash ROM firmware is no good. Update. 5. DSP or MPU is broken. Replace MPU. DSP is impossible to replace, so replace with a new PC board.
	Continue to display "05"	Writing from MPU to DSP is no good.	1. Flash ROM firmware is no good, update. 2. Check DSPSDO pin of MPU by oscilloscope. If no signal, find out bad part connected. 3. Flash ROM or SDRAM is no good, replace. 4. DSP or MPU is broken, replace the same method as above 5.
	Continue to display "09" to "10"	DSP program does not run properly. Flash ROM or SDRAM is no good.	1. Flash ROM firmware is no good, update. 2. Flash ROM or SDRAM is broken, replace.
	Continue to display "19"	The unit was powered off during DSP firmware updating.	Initialize the unit. (Press STANDBY/ON button while pushing VCR/DVR button when the unit is powered on.)
	Display "21" to "23", then return and signal format indicator is flashing.	DSP program does not run properly. Flash ROM or SDRAM is no good.	1. Flash ROM firmware is no good, upgrade. 2. Flash ROM or SDRAM is broken, replace.
	Continue to display "24" to "27", or "40" to "43".	DSP program does not run properly. Or audio clock to DSP is no good.	1. Flash ROM program is no good, upgrade. 2. Flash ROM or SDRAM is broken, replace. 3. Check DSP drive clock freq. by oscilloscope. If no signal, find out bad part connected. 4. Check audio clock to DSP by oscilloscope. If no signal, find out bad part connected.
	Continue to display "29" to "32"	DSP setting is failed.	1. Flash ROM firmware is no good, upgrade. 2. Flash ROM or SDRAM is broken, replace.
⑨	Displayed audio encoding format is different from input signal.	Input signal to DSP is no good.	1. Confirm where the digital waveform stops between DIR and DSP by oscilloscope. 2. Q202, P8001 may relate. 3. Resolder pins of the bad part or replace it with new one.
⑩	"x" is displayed.	a. No input signal to DSP.	The same as above.
		b. Interface between DSP and MPU is no good.	1. Confirm where the digital waveform stops between MPU and DSP by oscilloscope. 2. P8001, P8002, P8003 may relate. 3. Resolder pins of the bad part or replace it with new one.
⑪	This identifies IC which outputs error.	The IC outputs error to MPU.	Replace the IC chip. DSP is impossible to replace, so replace with a new PC board.

DEBUG MODE-4

SERVICE INFORMATION MODE

Trouble Shooting by Displaying Service information

This service information display system is helpful in analyze the status when the unit goes into Protect mode and is powered off. Pay attention that the status will change if a button is pushed.

1. Press and hold down **DISPLAY** button, then press **ON/STANDBY** button while the unit is powered ON.
The version of main microprocessor is displayed only for 3 seconds.

<Ex.> Main1.03/08630A — Version of Main microprocessor
*Number depends on the version.

2. Press **SETUP** button within 3 seconds above, the following informations are displayed.

<Ex.> - 80 °F 27 DD Information Displayed

Power off Cause Temperature Volume Level Listenning Mode
P : Protect : xx F or xx C xx xx ---> Refer to the code list below.
- : Other

Listening Mode Code List

Code	Listening Mode	Code	Listening Mode	Code	Listening Mode
01	Pure Audio	26	Neo:6 Cinema	30	DTS-HD High Resolution
02	Direct	27	Neo:6 Music	30	DTS-HD Master Audio
03	Stereo	28	Neural Surround	30	DSD
04	Mono	40	PLII Movie THX	39	+PLIIX Movie
07	Mono Movie	41	PLIIX Movie THX	3A	+PLIIX Music
09	Orchestra	42	Neo:6 Cinema THX	38	Dolby EX
0A	Unplugged	43	PLII Movie THX Games	37	+Neo:6
0B	Studio-Mix	44	Neo:6 Cinema THX Games	31	DTS Matrix
0C	TV Logic	29	Neural-THX	31	DTS Discrete
0D	All CH Stereo	30	Dolby Digital	50	THX Cinema
0E	Full Mono	30	DTS	58	THX Surround EX
0F	PLII Movie T-D	3B	DTS96/24	5C	THX Ultra2 Cinema
20	PLII Movie	30	AAC	5D	THX Music Mode
21	PLII Music	30	MultiCh	5E	THX Games
22	PLII Game	30	Dolby Digital Plus	59	+PLIIX Movie THX
23	PLIIX Movie	30	Dolby TrueHD	57	+Neo:6 THX
24	PLIIX Music			3D	+Neural-THX
25	PLIIX Game			51	DTX Matrix THX
				52	DTS Discrete THX

3. Press **SETUP** button again. The following information are displayed.

<Ex.> 01:23 10hour

Time after Power on Time after Initialize
xx : xx xx hour

4. Press **RETURN** button. The information will be cleared.

<Ex.> ProtectData CLR

DEBUG MODE-5

HDMI DEBUG MODE-1/2

HDMI-related operations can be checked to some extent by displaying HDMI debug mode.

To enter this mode

Hold down **DISPLAY** button for **3** seconds. Information display will last for about 8 seconds.

Content of Display

FL Display

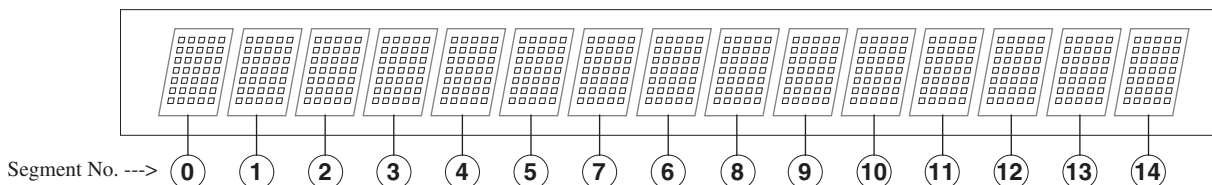

Video Input Format	Status Description	FL segment No. --->	0	1	2	3	4	5	6	7	8	9	10	11	12	13	14
Normal Source Video Formats	Description --->																
	Source Device Video Format : OK Sink Device EDID : OK Normal State	Display ---> (Example)	1	0	8	0	i	/	6	0	→	1	0	8	0	i	
	Source Device Video Format : OK Sink Device Hot plug : Low Error State ---> Remedy [1]		1	0	8	0	i	/	6	0	→	0	F	F			
	Source Device Video Format : OK Sink Device HDCP Authentication : Fail Error State ---> Remedy [2]		1	0	8	0	i	/	6	0	→	[1	0	8	0]
	Source Device Video Format : OK Sink Device Resolution : Error Error State ---> Remedy [3]		1	0	8	0	i	/	6	0	→	1	0	8	0	x	
	Source Device Video Format : OK Sink Device EDID Reading : Error Error State ---> Remedy [4]		1	0	8	0	i	/	6	0	→	1	0	8	0	#	
	Source Device Video Format : OK Sink Device : Busy (Cannot accept HDMI signal) Error State ---> Remedy [5]		1	0	8	0	i	/	6	0	→	1	0	8	0	i	*
Description --->																	

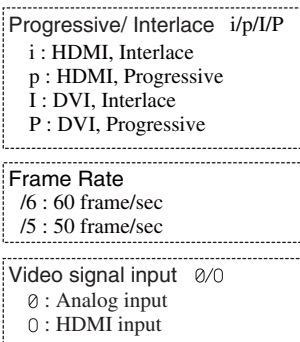

DEBUG MODE-6

HDMI DEBUG MODE-2/2

Video Input Format	Status Description	FL segment No. --->	①	②	③	④	⑤	⑥	⑦	⑧	⑨	⑩	⑪	⑫	⑬	⑭	
Source Device Video resolution is not Determined	Video signal route : HDMI Through Error State ---> Remedy [6]		U	N	K	N	O	W	N	→	-	-	-	-	-	-	-
	Video signal route : Via Video Signal Processor Error State ---> Remedy [7]		U	n	k	n	o	w	n	→	-	-	-	-	-	-	-
Description --->			Input Horizontal Resolution		Input Vertical Resolution		i/p/I/P	Frame Rate									
Source video Format : PC Format	Source Device Video Format : OK, Sink Device EDID : OK Normal State		1	9	2	0	x	1	2	0	0	P	/	6	0		
	Source Device Video Format : OK, Sink Device Hot plug : Low Error State ---> Remedy [8]		1	9	2	0	-	1	2	0	0	P	/	6	0		
	Source Device Video Format : OK, Sink Device HDCP Authentication : Fail Error State ---> Remedy [9]		1	9	2	0	x	1	2	0	0	P	/	6	0		
	Source Device Video Format : OK, Sink Device Busy (Cannot accept HDMI signal) Error State ---> Remedy [10]		1	9	2	0		1	2	0	0	P	/	6	0	*	
	VGA input via DVI-HDMI conversion cable Normal State		#	U	G	A						→		#	U	G	A
	VGA input via HDMI cable Normal State			U	G	A						→			U	G	A

<Notes>

In the case that horizontal resolution is doubled, “#” is marked at the head of the resolution.

In the case that horizontal resolution is quadrupled, “*” is marked at the head of the resolution.

Resolution example : 480p, 576p, 480i, 576i, 240p, 288p

Source device example : Panasonic DVD player's Double Resolution of 480p.

Blue-ray player's Quadruple Resolution of 480p when TrueHD etc. is played back.

Remedy for Error State

Remedy No.	Remedy
[1]	The most possible cause is the hardware trouble of Sink device. Fix it.
[2]	Refer to HDCP and Authentication error in “DEBUG MODE-7”. Follow the procedure.
[3]	Refer to Resolution error in “DEBUG MODE-7”. Follow the procedure.
[4]	Refer to EDID error in “DEBUG MODE-7”. Follow the procedure.
[5]	Check other HDMI Inputs of AV receiver. If NG, the most possible cause is the hardware trouble of Sink device. Fix it.
[6]	Check Source device output signal. No signal, or the format is not supported by both HDMI and AV receiver.
[7]	The same as [6].
[8]	The most possible cause is the hardware trouble of Sink device. Fix it.
[9]	The same as [2].
[10]	The same as [5].

DEBUG MODE-7
HDMI TROUBLESHOOT-1/3

HDMI VIDEO SETUP TROUBLE

This trouble shooting map focuses on the video setup errors regarding HDMI.
 For reference, read TX-SR606 Owner's Manual.
 Analysis written below is of typical cases. So, more detailed check may need in actual cases.

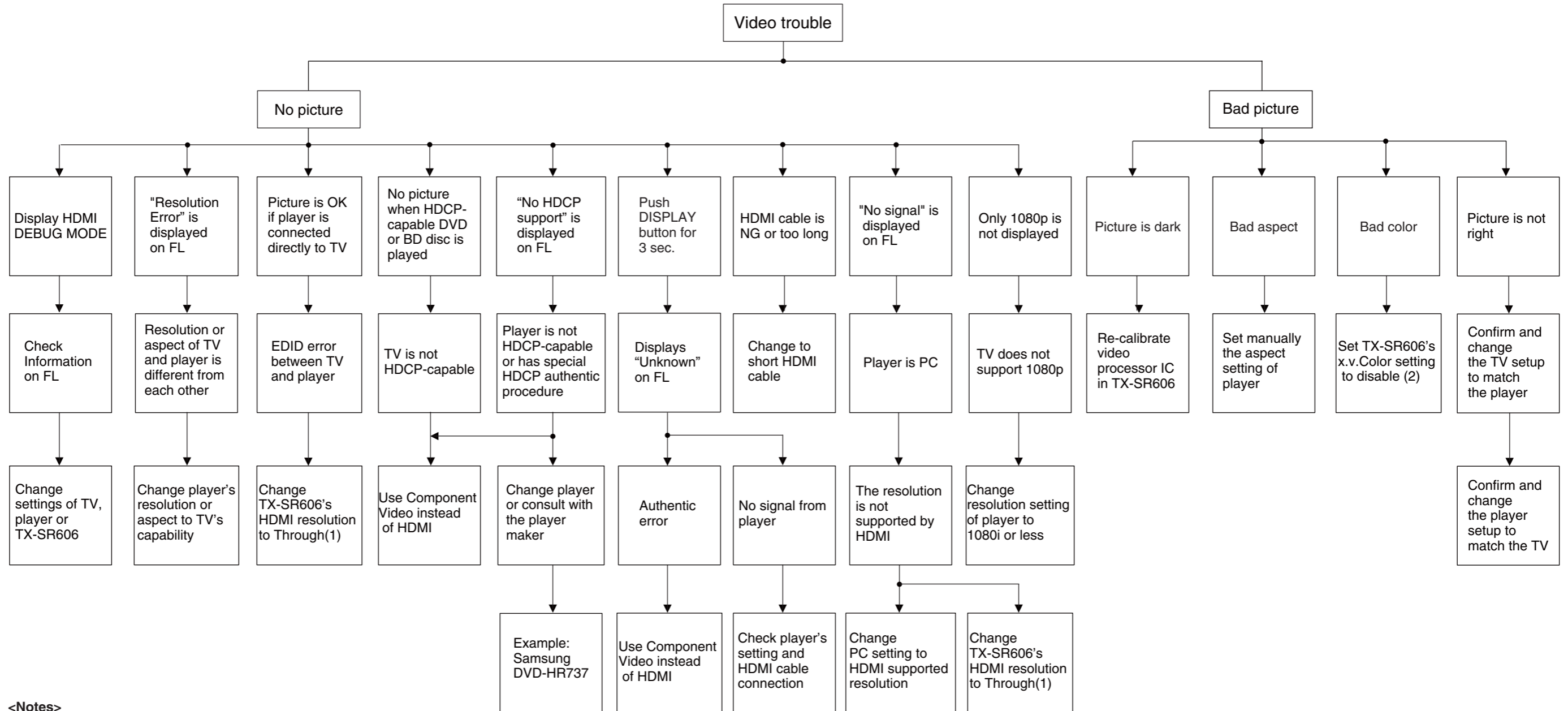

<Notes>
 (1) Refer to Setup Menu 7-5. HDMI Setting
 Resolution : Through.
 (2) Refer to Setup Menu 7-5. HDMI Setting
 x.v.Color : Disable.

DEBUG MODE-8

HDMI TROUBLESHOOT-2/3

HDMI AUDIO SETUP TROUBLE

This trouble shooting map focuses on the audio setups and connections regarding HDMI.
For reference, read TX-SR606 Owner's Manual.
Analysis written below is of typical cases. So, more detailed check may need in actual cases.

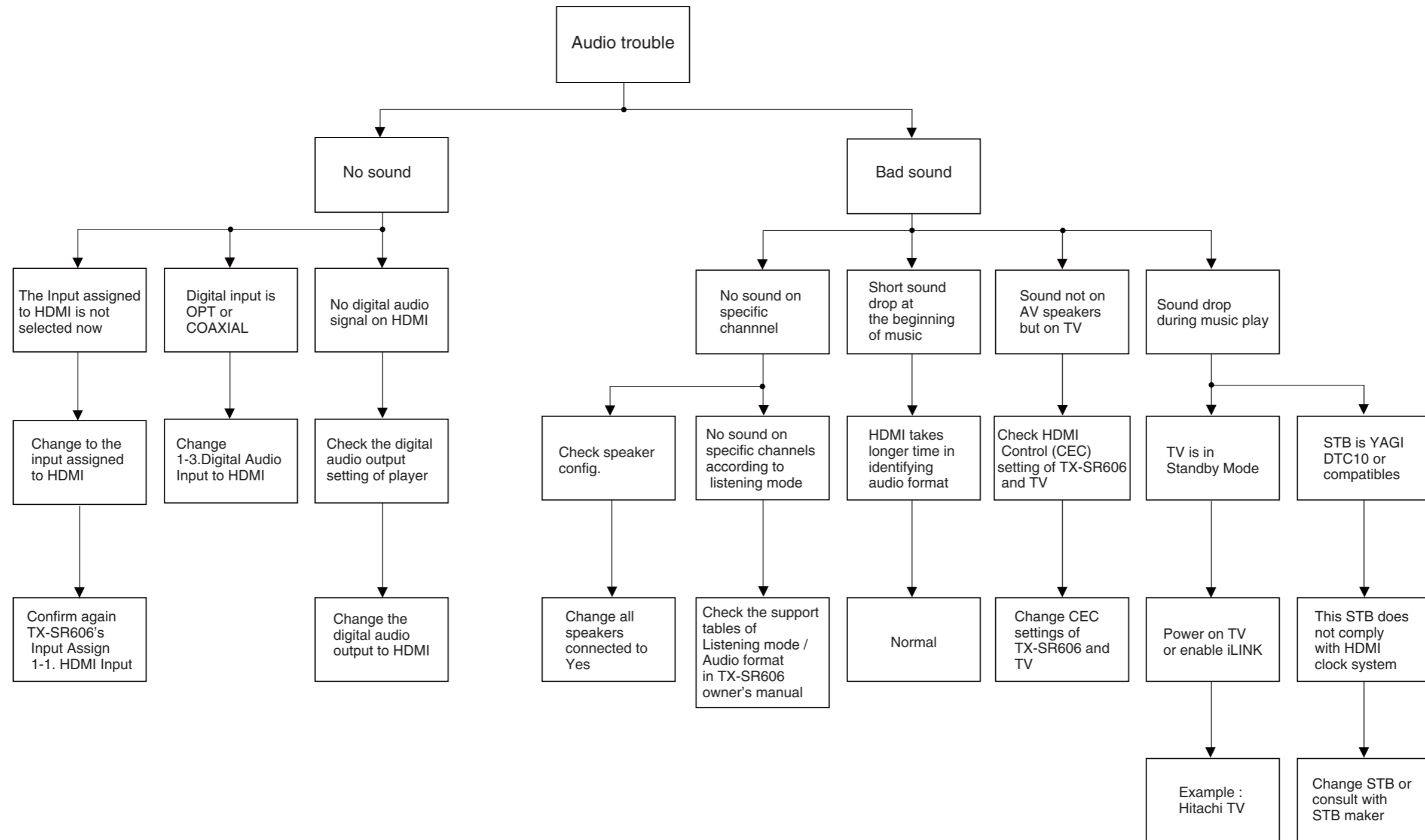

DEBUG MODE-9

HDMI TROUBLESHOOT-3/3

HDMI HARDWARE TROUBLE

<Notes>

1. This trouble shooting map focuses on the HDMI hardware troubles.
For details, refer to TX-SR606 Block Diagrams and Schematic Diagrams.
2. Analysis written below is of typical cases. So, more detailed check may need in actual cases.
3. Before replace ICs or pcb below, resolder the pins first to save resources.

Main Device (IC)

Circuit No.	Function	Description
Q701	Main microprocessor	MPD70F3746
Q8001	Video processor	FLI30502
Q8501	HDMI Receiver	SiI9135
Q8162	HDMI Switch	SiI9185
Q8401	HDMI Transmitter	SiI9134

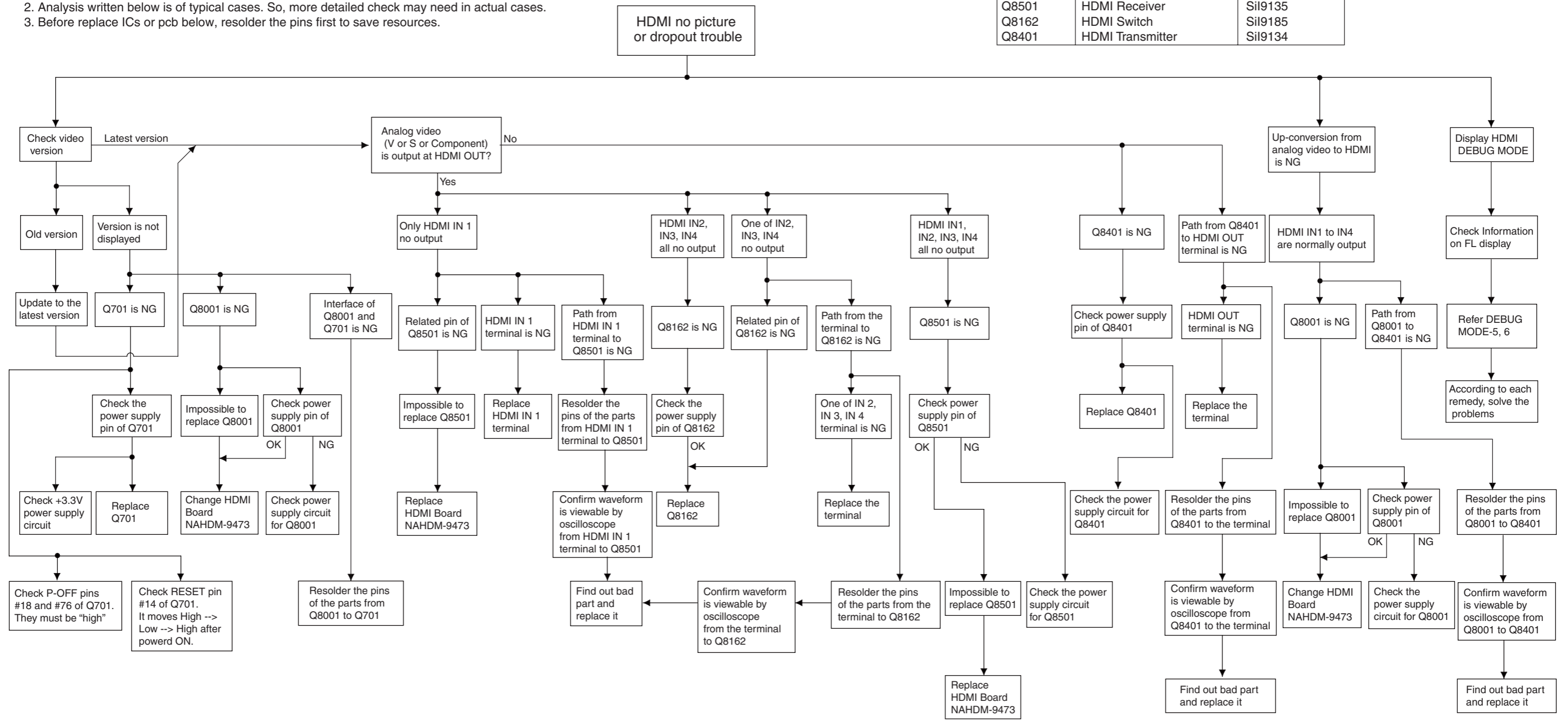

ADJUSTMENT PROCEDURE-1

IDLING CURRENT ADJUSTMENT

[When]

1. Exchange Power transistor (Q6050 - Q6056, Q6060 - Q6066).
2. Amplifier PC board (NAAF-9419).

[Procedure]

Refer to "ADJUSTMENT PROCEDURE-2 " for the adjustment points and the test points.

<Note> No load and No signal

1. Before idling adjustment, turn the trimming resistors fully to counter clockwise.
2. Connect the dc voltmeter to test points, using two 100 ohm resistors between the poles of the jig terminal and the dc voltmeter terminals.

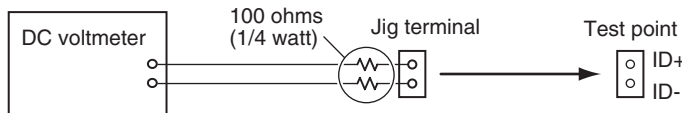

3. Connect the ac power cord to a wall outlet. And press ON/STANDBY button to turn the power on.
4. Adjust the trimming resistors as the following procedure immediately after power on.

Channel	Adjustment point	Test point	Adjustment value
Front Left	R6041	P6081	2.5 mV
Front Right	R6042	P6082	
Center	R6040	P6080	
Surround Left	R6043	P6083	1.5 mV
Surround Right	R6044	P6084	
Surround Back Left	R6045	P6085	
Surround Back Right	R6046	P6086	

5. Wait for 4 - 6 minutes. (Heat running)
6. Re-adjust the trimming resistors as the following procedure.

Channel	Measured value	Adjustment value	Specifications
Front Left, Front Right and Center	In below 9 mV →	9 mV	12 +/- 3 mV
	In case 9 - 11 mV →	Leave it as it is	
	In case over 11 mV →	11 mV	
Surround Left Surround Right Surround Back Left Surround Back Right	In case below 6 mV →	6 mV	9 +/- 3 mV
	In case 6 - 8 mV →	Leave it as it is	
	In case over 8 mV →	8 mV	

<Notes>

Idling currents are stabilized in about 10 minutes after power on.

7. Disconnect the dc voltmeter.
8. Press ON/STANDBY button to turn the power off. And disconnect the ac power cord.

ADJUSTMENT PROCEDURE-2 IDLING CURRENT ADJUSTMENT

Adjustment points and the test points

Adjustment point
(Trimming resistor) Test point

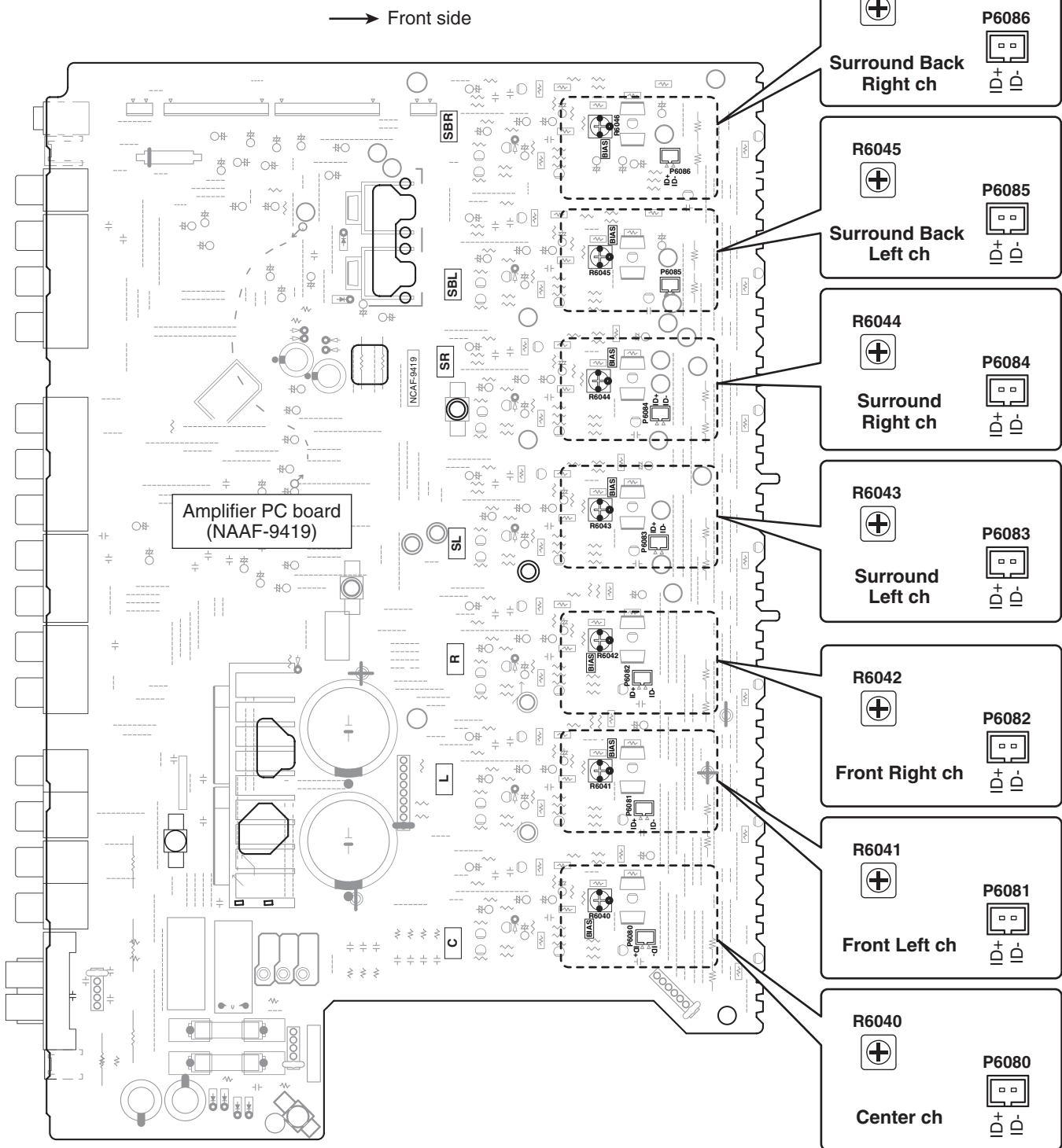

HT-R960**<Note>**

Parts marked by "NSP" are generally unavailable because they are not in our Master Spare Parts List.

**NOTE : THE COMPONENTS IDENTIFIED BY THE MARK
! ARE CRITICAL FOR RISK OF FIRE AND
ELECTRIC SHOCK. REPLACE ONLY WITH PART
NUMBER SPECIFIED.**

<Notes>

<MDC> : Canadian model

<MPP> : European model

EXPLODED VIEW PARTS LIST

	REF. NO.	PART NAME	DESCRIPTION	Q'TY	PART NO. (SN)	REMARKS
EXPLODED	A001	CHASSIS	(FRONT)	1	27100513A	
EXPLODED	A002	SCREW	3TTB+8B(3CM)SR	5	801637	
EXPLODED	A003	B PLATE	---	1	28133425	
EXPLODED	A004	RETAINER	(F)	1	27142099	
EXPLODED	A005	SCREW	3TTB+8B(3CM)SR	2	801637	
EXPLODED	A011	SCREW	2.6TTB+8B(3BC)	18	838426088GR	
EXPLODED	A012	SCREW	2.6TTB+8B(3BC)	3	838426088GR	
EXPLODED	A013	WIRE TIE	BSK-1	8	260208	
EXPLODED	A016	SCREW	3TTB+8B(3CM)SR	1	801637	
EXPLODED	A018	HOLDER	KGLS-22S	3	27190369	
EXPLODED	A019	HOLDER	KGLS-14S	1	27190164	
EXPLODED	A020	HOLDER	KGLS-16RT	2	27190511	
EXPLODED	A021	HOLDER	KGPS-16RF	5	27190991	
EXPLODED	A022	HOLDER	KGLS-10RT	1	27190428A	
EXPLODED	A030	SCREW	4TTC+8C(3BC)	4	830440089GR	
EXPLODED	A031	SPACER	---	1	27270439	
EXPLODED	A033	LABEL	(PT)	1	29363379-1	
EXPLODED	A035	HOLDER	KGLS-14RT	1	27190524	
EXPLODED	A037	BUSHING	S-RELIEF #2271	1	27300750	!

EXPLODED	A039	TAPE	TAPE(CLOTH-16U)	(1)	29110083	
EXPLODED	A040	HEAT SINK	(AS)	1	27160602A	
EXPLODED	A041	BRACKET	(HT-L)	1	27131016B	
EXPLODED	A042	BRACKET	(HT-R)	1	27131017A	
EXPLODED	A043	SCREW	3TTB+8B(3CM)SR	4	801637	
EXPLODED	A044	SCREW	3TTB+8B(3CM)SR	4	801637	
EXPLODED	A046	SCREW	3TTB+8B(3CM)SR	2	801637	
EXPLODED	A047	SCREW	3TTB+8B(3CM)SR	2	801637	
EXPLODED	A048	SCREW	3TTB+8B(3CM)SR	1	801637	
EXPLODED	A049	SCREW	3SMS8W.SW+14B(CU)	14	801634	
EXPLODED	A050	IB CUSHION	W15 x 3t TAPE	1	28141585	
EXPLODED	A052	SCREW	3TTB+8B(3CM)SR	1	801637	
EXPLODED	A055	KNOB	VOLAS(B)	1	28326654A	
EXPLODED	A060	COVER	(B) (Bent)	1	28210010	
EXPLODED	A060	COVER	(B) (Not bent)	1	28210010Z	<MDC>
EXPLODED	A061	SCREW	3TTB+8B(3BC)	6	838430088GR	
EXPLODED	A062	CUSHION	---	2	28141681	
EXPLODED	A066	BOTTOM LEG	TX-SR506	4	27175441A	
EXPLODED	A067	SCREW	3TTB+10B(3BC)	4	838430108GR	
EXPLODED	A068	WASHER	W3 x 8F(3CM)	4	87613008GR	
EXPLODED	A071	CUSHION	---	3	28141688	
EXPLODED	A072	CHASSIS	506	1	---	NSP
EXPLODED	A073	F PANEL	(B)MDC/H960	1	27213089A	<MDC>
EXPLODED	A073	F PANEL	(B)MPP/H960	1	27213090A	<MPP>
EXPLODED	A074	KNOB	(PRE)/B	1	28326618	
EXPLODED	A075	KNOB	(A)/B	1	28326615	
EXPLODED	A076	KNOB	(STNBY)/B	1	28326621	
EXPLODED	A077	BADGE	BADGE	1	28135244	
EXPLODED	A083	CLEAR PLT	HT-R960(B)DD/PP	1	28192193	
EXPLODED	A089	SCREW	3TTB+8B(3BC)	3	838430088GR	
EXPLODED	A093	REAR PANEL	HT-R960MDC	1	27123799A	<MDC>
EXPLODED	A093	REAR PANEL	HT-R960MPP	1	27123800A	<MPP>
EXPLODED	A096	SCREW	3P+6FN(3BC)	5	82143006GR	

EXPLODED:	A097	SCREW	3TTB+8B(3BC)	30	838430088GR	
EXPLODED:	A102	LABEL	(COVER)	1	29364123	
EXPLODED:	A103	LABEL	(SP)	1	29390250A	
EXPLODED:	A104	LABEL	(SP_RE)TX-SR506	1	29390384	
EXPLODED:	A109	LABEL	HOOKUP-ONKYO	1	29363194	<MDC>
EXPLODED:	Q6050	TR	2SC5242-O	1	2202843	!
EXPLODED:	Q6050 or	TR	2SC5242-R	(1)	2202842	!
EXPLODED:	Q6050A	ISO SHEET	AC238	2	223024	
EXPLODED:	Q6050B	ISO SHEET	ISO SHEET	6	223041	
EXPLODED:	Q6051	TR	2SC5242-O	1	2202843	!
EXPLODED:	Q6051 or	TR	2SC5242-R	(1)	2202842	!
EXPLODED:	Q6052	TR	2SC5242-O	1	2202843	!
EXPLODED:	Q6052 or	TR	2SC5242-R	(1)	2202842	!
EXPLODED:	Q6053	TR	2SC5242-O	1	2202843	!
EXPLODED:	Q6053 or	TR	2SC5242-R	(1)	2202842	!
EXPLODED:	Q6054	TR	2SC5242-O	1	2202843	!
EXPLODED:	Q6054 or	TR	2SC5242-R	(1)	2202842	!
EXPLODED:	Q6055	TR	2SC5242-O	1	2202843	!
EXPLODED:	Q6055 or	TR	2SC5242-R	(1)	2202842	!
EXPLODED:	Q6056	TR	2SC5242-O	1	2202843	!
EXPLODED:	Q6056 or	TR	2SC5242-R	(1)	2202842	!
EXPLODED:	Q6060	TR	2SA1962-O	1	2202833	!
EXPLODED:	Q6060 or	TR	2SA1962-R	(1)	2202832	!
EXPLODED:	Q6061	TR	2SA1962-O	1	2202833	!
EXPLODED:	Q6061 or	TR	2SA1962-R	(1)	2202832	!
EXPLODED:	Q6062	TR	2SA1962-O	1	2202833	!
EXPLODED:	Q6062 or	TR	2SA1962-R	(1)	2202832	!
EXPLODED:	Q6063	TR	2SA1962-O	1	2202833	!
EXPLODED:	Q6063 or	TR	2SA1962-R	(1)	2202832	!
EXPLODED:	Q6064	TR	2SA1962-O	1	2202833	!
EXPLODED:	Q6064 or	TR	2SA1962-R	(1)	2202832	!
EXPLODED:	Q6065	TR	2SA1962-O	1	2202833	!
EXPLODED:	Q6065 or	TR	2SA1962-R	(1)	2202832	!

EXPLODED:	Q6066	TR	2SA1962-O	1	2202833	!
EXPLODED:	Q6066 or	TR	2SA1962-R	(1)	2202832	!
EXPLODED:	<Note>					
EXPLODED:	Must use the same HFE rank mutually about the following parts.					
EXPLODED:	Ref. No. : Q6050 - 6056, Q6060 - Q6066					
EXPLODED:	T901	P TRANS	NPT-1574D	1	2301941	!, <MDC>
EXPLODED:	T901	P TRANS	NPT-1574P	1	2301942	!, <MPP>
EXPLODED:	P101	FFC	NCFC7-132512	1	2047132512	
EXPLODED:	P701	FFC	NCFC7-332512	1	2047332512	
EXPLODED:	P901	AC CORD	AS-UC-2	1	253333VOL	!, <MDC>
EXPLODED:	P901 or	AC CORD	AS-UC-2	(1)	253368BLTK	!, <MDC>
EXPLODED:	P901 or	AC CORD	AS-UC-2	(1)	253368AYUN	!, <MDC>
EXPLODED:	P901 or	AC CORD	AS-UC-2	(1)	253368HSN	!, <MDC>
EXPLODED:	P901	AC CORD	AS-CEE-2	1	253306VOL	!, <MPP>
EXPLODED:	P901 or	AC CORD	AS-CEE-2	(1)	253374YUN	!, <MPP>
EXPLODED:	P2801	FFC	NCFC7-131012	1	2047131012	
EXPLODED:	P6601A	P RIVET	JB-407A-C	14	880052	<MPP>
EXPLODED:	F901	FUSE	8A-UL/T-233	1	252329GR	!, <MDC>
EXPLODED:	F901 or	FUSE	8A-T/UL-ST2	(1)	252261GR	!, <MDC>
EXPLODED:	F901	FUSE	4A-SE-EAK FUSE	1	252077GR	!, <MPP>
EXPLODED:	F901 or	FUSE	4A-SE-TL250V	(1)	252277GR	!, <MPP>
EXPLODED:	F901C	LABEL	T4AL250V	1	29361732A	!, <MPP>
EXPLODED:	F6901	FUSE	10A-UL/T-233	1	252330GR	!
EXPLODED:	F6901 or	FUSE	10A-T/UL-ST2	(1)	252333GR	!
EXPLODED:	F6902	FUSE	10A-UL/T-233	1	252330GR	!
EXPLODED:	F6902 or	FUSE	10A-T/UL-ST2	(1)	252333GR	!
EXPLODED:	U01	AMPLIFIER PC board ass'y	NAAF-9419-1J*	1	1B211519-1J	<MDC>
EXPLODED:	U01	AMPLIFIER PC board ass'y	NAAF-9419-1K*	1	1B211519-1K	<MPP>
EXPLODED:	U02	TRANS. SEC. TERMINAL PC board ass'y	NAPS-9420-1J	1	1B211520-1J	<MDC>
EXPLODED:	U02	TRANS. SEC. TERMINAL PC board ass'y	NAPS-9420-1K	1	1B211520-1K	<MPP>
EXPLODED:	U03	THERMAL SENSOR PC board ass'y	NAETC-9421-1J	1	---	NSP, <MDC>
EXPLODED:	U03	THERMAL SENSOR PC board ass'y	NAETC-9421-1K	1	---	NSP, <MPP>
EXPLODED:	U04	HOLDER PC board	NAETC-9422-1J	1	---	NSP, <MDC>

EXPLODED	U04	HOLDER PC board	NAETC-9422-1K	1	---	NSP, <MPP>
EXPLODED	U10	DISPLAY PC board ass'y	NADIS-9430-1L*	1	1B211530-1L	<MDC>
EXPLODED	U10	DISPLAY PC board ass'y	NADIS-9430-1M*	1	1B211530-1M	<MPP>
EXPLODED	U11	SWITCH PC board ass'y	NADIS-9431-1L	1	1B211531-1L	<MDC>
EXPLODED	U11	SWITCH PC board ass'y	NADIS-9431-1M	1	1B211531-1M	<MPP>
EXPLODED	U12	POWER SUPPLY PC board ass'y	NAPS-9432-1L	1	1B211532-1L	<MDC>
EXPLODED	U12	POWER SUPPLY PC board ass'y	NAPS-9432-1M	1	1B211532-1M	<MPP>
EXPLODED	U13	TRANS. SEC. TERMINAL PC board ass'y	NAPS-9433-1L	1	1B211533-1L	<MDC>
EXPLODED	U13	TRANS. SEC. TERMINAL PC board ass'y	NAPS-9433-1M	1	1B211533-1M	<MPP>
EXPLODED	U14	HEADPHONE JACK PC board ass'y	NAETC-9435-1L	1	---	NSP, <MDC>
EXPLODED	U14	HEADPHONE JACK PC board ass'y	NAETC-9435-1M	1	---	NSP, <MPP>
EXPLODED	U17	HOLDER PC board	NAETC-9441-1L	1	---	NSP, <MDC>
EXPLODED	U17	HOLDER PC board	NAETC-9441-1M	1	---	NSP, <MPP>
EXPLODED	U32	MICROPROCESSOR PC board ass'y	NADG-9462-1H*	1	1B211562-1H	NSP, <MDC>
EXPLODED	U32	MICROPROCESSOR PC board ass'y	NADG-9462-1J*	1	1B211562-1J	NSP, <MPP>
EXPLODED	U36	VIDEO PC board ass'y	NAVD-9467-1N*	1	1B211567-1N	<MDC>
EXPLODED	U36	VIDEO PC board ass'y	NAVD-9467-1P*	1	1B211567-1P	<MPP>
EXPLODED	U37	SPEAKER TERMINAL PC board ass'y	NATRM-9468-N	1	1B211568-1N	<MDC>
EXPLODED	U37	SPEAKER TERMINAL PC board ass'y	NATRM-9468-P	1	1B211568-1P	<MPP>
EXPLODED	U41	HDMI PC board ass'y	NAHDM-9473-1A*	1	1B211573-1A	
EXPLODED	U45	TUNER UNIT	ENG06507QFUS	1	240156	<MDC>
EXPLODED	U45 or	TUNER UNIT	FAE385-A11US	(1)	240152	<MDC>
EXPLODED	U45	TUNER UNIT	ENG07505QFEU	1	240158	<MPP>
EXPLODED	U45 or	TUNER UNIT	FAE485-E11EU	(1)	240154	<MPP>

HT-R960

PC BOARD PARTS LIST

- PCB1 **U01** AMPLIFIER PC BOARD (NAAF-9419-1J/ 1K)
- PCB1 **U02** TRANS. SEC. TERMINAL PC BOARD (NAPS-9420-1J/ 1K)
- PCB1 **U03** THERMAL SENSOR PC BOARD (NAETC-9421-1J/ 1K)

PCB1	CIRCUIT NO.	PART NAME	DESCRIPTION	Q'TY	PART NO. (SN)	REMARKS
------	-------------	-----------	-------------	------	---------------	---------

PCB1	Q5000	TR	2SC2240-BL(TPE2_F)	1	2211406T
PCB1	Q5001	TR	2SC2240-BL(TPE2_F)	1	2211406T
PCB1	Q5002	TR	2SC2240-BL(TPE2_F)	1	2211406T
PCB1	Q5003	TR	2SC2240-BL(TPE2_F)	1	2211406T
PCB1	Q5004	TR	2SC2240-BL(TPE2_F)	1	2211406T
PCB1	Q5005	TR	2SC2240-BL(TPE2_F)	1	2211406T
PCB1	Q5006	TR	2SC2240-BL(TPE2_F)	1	2211406T
PCB1	Q5010	TR	2SC2240-BL(TPE2_F)	1	2211406T
PCB1	Q5011	TR	2SC2240-BL(TPE2_F)	1	2211406T
PCB1	Q5012	TR	2SC2240-BL(TPE2_F)	1	2211406T
PCB1	Q5013	TR	2SC2240-BL(TPE2_F)	1	2211406T
PCB1	Q5014	TR	2SC2240-BL(TPE2_F)	1	2211406T
PCB1	Q5015	TR	2SC2240-BL(TPE2_F)	1	2211406T
PCB1	Q5016	TR	2SC2240-BL(TPE2_F)	1	2211406T
PCB1	Q5030	TR	2SA949-Y(TPE6_F)	1	2211354T
PCB1	Q5031	TR	2SA949-Y(TPE6_F)	1	2211354T
PCB1	Q5032	TR	2SA949-Y(TPE6_F)	1	2211354T
PCB1	Q5033	TR	2SA949-Y(TPE6_F)	1	2211354T
PCB1	Q5034	TR	2SA949-Y(TPE6_F)	1	2211354T
PCB1	Q5035	TR	2SA949-Y(TPE6_F)	1	2211354T
PCB1	Q5036	TR	2SA949-Y(TPE6_F)	1	2211354T
PCB1	Q5040	TR	2SC2229-Y(TPE6_F)	1	2211634T
PCB1	Q5041	TR	2SC2229-Y(TPE6_F)	1	2211634T
PCB1	Q5042	TR	2SC2229-Y(TPE6_F)	1	2211634T
PCB1	Q5043	TR	2SC2229-Y(TPE6_F)	1	2211634T
PCB1	Q5044	TR	2SC2229-Y(TPE6_F)	1	2211634T
PCB1	Q5045	TR	2SC2229-Y(TPE6_F)	1	2211634T
PCB1	Q5046	TR	2SC2229-Y(TPE6_F)	1	2211634T
PCB1	Q5050	TR	2SC2240-BL(TPE2_F)	1	2211406T
PCB1	Q5051	TR	2SC2240-BL(TPE2_F)	1	2211406T
PCB1	Q5052	TR	2SC2240-BL(TPE2_F)	1	2211406T
PCB1	Q5053	TR	2SC2240-BL(TPE2_F)	1	2211406T
PCB1	Q5054	TR	2SC2240-BL(TPE2_F)	1	2211406T

PCB1	Q5055	TR	2SC2240-BL(TPE2_F)	1	2211406T
PCB1	Q5056	TR	2SC2240-BL(TPE2_F)	1	2211406T
PCB1	Q5501	IC	R2S15211FP	1	22242297R3
PCB1	Q5503	IC	NJM4580M-D	1	22241448R2
PCB1	Q5600	TR	RN1441	1	2215410R2
PCB1	Q5601	TR	RN1441	1	2215410R2
PCB1	Q5602	TR	RN1441	1	2215410R2
PCB1	Q5603	TR	RN1441	1	2215410R2
PCB1	Q5604	TR	RN1441	1	2215410R2
PCB1	Q5605	TR	RN1441	1	2215410R2
PCB1	Q5606	TR	RN1441	1	2215410R2
PCB1	Q5607	TR	RN1441	1	2215410R2
PCB1	Q5610	TR	RN1441	1	2215410R2
PCB1	Q5630	IC	NJM4580M-D	1	22241448R2
PCB1	Q5670	IC	78M15HF(NJM78M15FA)	1	222780155JRC
PCB1	Q5670 or	IC	UPC78M15AHF-AZ	(1)	222780155NEC
PCB1	Q5670A	HEAT-SINK	HEAT-SINK(RAD-68)	1	27160211
PCB1	Q5670B	SCREW	3P+10FN(3BC)	1	82143010GR
PCB1	Q5671	IC	79M15HF(NJM79M15FA)	1	222790155JRC
PCB1	Q5671 or	IC	UPC79M15HF-AZ	(1)	222790155NEC
PCB1	Q5671A	HEAT-SINK	HEAT-SINK(RAD-68)	1	27160211
PCB1	Q5671B	SCREW	3P+10FN(3BC)	1	82143010GR
PCB1	Q6000	TR	2SC1740S-S	1	2213285T
PCB1	Q6001	TR	2SC1740S-S	1	2213285T
PCB1	Q6002	TR	2SC1740S-S	1	2213285T
PCB1	Q6003	TR	2SC1740S-S	1	2213285T
PCB1	Q6004	TR	2SC1740S-S	1	2213285T
PCB1	Q6005	TR	2SC1740S-S	1	2213285T
PCB1	Q6006	TR	2SC1740S-S	1	2213285T
PCB1	Q6010	TR	2SC1740S-S	1	2213285T
PCB1	Q6011	TR	2SC1740S-S	1	2213285T
PCB1	Q6012	TR	2SC1740S-S	1	2213285T
PCB1	Q6013	TR	2SC1740S-S	1	2213285T

PCB1	Q6014	TR	2SC1740S-S	1	2213285T
PCB1	Q6015	TR	2SC1740S-S	1	2213285T
PCB1	Q6016	TR	2SC1740S-S	1	2213285T
PCB1	Q6030	TR	2SC5171(ONK_Q)	1	2203010
PCB1	Q6030 or	TR	2SC5993-Q_P	(1)	2217161
PCB1	Q6031	TR	2SC5171(ONK_Q)	1	2203010
PCB1	Q6031 or	TR	2SC5993-Q_P	(1)	2217161
PCB1	Q6032	TR	2SC5171(ONK_Q)	1	2203010
PCB1	Q6032 or	TR	2SC5993-Q_P	(1)	2217161
PCB1	Q6033	TR	2SC5171(ONK_Q)	1	2203010
PCB1	Q6033 or	TR	2SC5993-Q_P	(1)	2217161
PCB1	Q6034	TR	2SC5171(ONK_Q)	1	2203010
PCB1	Q6034 or	TR	2SC5993-Q_P	(1)	2217161
PCB1	Q6035	TR	2SC5171(ONK_Q)	1	2203010
PCB1	Q6035 or	TR	2SC5993-Q_P	(1)	2217161
PCB1	Q6036	TR	2SC5171(ONK_Q)	1	2203010
PCB1	Q6036 or	TR	2SC5993-Q_P	(1)	2217161
PCB1	Q6040	TR	2SA1930(ONK_Q)	1	2203000
PCB1	Q6040 or	TR	2SA2140-Q_P	(1)	2217151
PCB1	Q6041	TR	2SA1930(ONK_Q)	1	2203000
PCB1	Q6041 or	TR	2SA2140-Q_P	(1)	2217151
PCB1	Q6042	TR	2SA1930(ONK_Q)	1	2203000
PCB1	Q6042 or	TR	2SA2140-Q_P	(1)	2217151
PCB1	Q6043	TR	2SA1930(ONK_Q)	1	2203000
PCB1	Q6043 or	TR	2SA2140-Q_P	(1)	2217151
PCB1	Q6044	TR	2SA1930(ONK_Q)	1	2203000
PCB1	Q6044 or	TR	2SA2140-Q_P	(1)	2217151
PCB1	Q6045	TR	2SA1930(ONK_Q)	1	2203000
PCB1	Q6045 or	TR	2SA2140-Q_P	(1)	2217151
PCB1	Q6046	TR	2SA1930(ONK_Q)	1	2203000
PCB1	Q6046 or	TR	2SA2140-Q_P	(1)	2217151
PCB1	Q6070	TR	2SC2240-BL(TPE2_F)	1	2211406T
PCB1	Q6070 or	TR	2SC2240-GR	(1)	2211405T

PCB1	Q6071	TR	2SC2240-BL(TPE2_F)	1	2211406T
PCB1	Q6071 or	TR	2SC2240-GR	(1)	2211405T
PCB1	Q6072	TR	2SC2240-BL(TPE2_F)	1	2211406T
PCB1	Q6072 or	TR	2SC2240-GR	(1)	2211405T
PCB1	Q6073	TR	2SC2240-BL(TPE2_F)	1	2211406T
PCB1	Q6073 or	TR	2SC2240-GR	(1)	2211405T
PCB1	Q6074	TR	2SC2240-BL(TPE2_F)	1	2211406T
PCB1	Q6074 or	TR	2SC2240-GR	(1)	2211405T
PCB1	Q6075	TR	2SC2240-BL(TPE2_F)	1	2211406T
PCB1	Q6075 or	TR	2SC2240-GR	(1)	2211405T
PCB1	Q6076	TR	2SC2240-BL(TPE2_F)	1	2211406T
PCB1	Q6076 or	TR	2SC2240-GR	(1)	2211405T
PCB1	Q6380	IC	LM61CIZ	1	22242212
PCB1	Q6380A	RETAINER	(PTH)	1	27141884-1
PCB1	Q6701	TR	2SC2712-GR	1	2213145R2
PCB1	Q6701 or	TR	KTC3875-GR	(1)	2216175R2
PCB1	Q6702	TR	2SC2712-GR	1	2213145R2
PCB1	Q6702 or	TR	KTC3875-GR	(1)	2216175R2
PCB1	Q6703	TR	2SA1163-BL(TE85L_F)	1	2216756R2
PCB1	Q6707	TR	2SC2712-GR	1	2213145R2
PCB1	Q6707 or	TR	KTC3875-GR	(1)	2216175R2
PCB1	D5000	ZENER D	MTZJ5.6B	1	224470562T
PCB1	D5001	ZENER D	MTZJ5.6B	1	224470562T
PCB1	D5002	ZENER D	MTZJ5.6B	1	224470562T
PCB1	D5003	ZENER D	MTZJ5.6B	1	224470562T
PCB1	D5004	ZENER D	MTZJ5.6B	1	224470562T
PCB1	D5005	ZENER D	MTZJ5.6B	1	224470562T
PCB1	D5006	ZENER D	MTZJ5.6B	1	224470562T
PCB1	D5671	ZENER D	MTZJ6.2B	1	224470622T
PCB1	D5672	ZENER D	MTZJ6.2B	1	224470622T
PCB1	D5673	DIODE	1SS133	1	223163T
PCB1	D5674	DIODE	1SS133	1	223163T
PCB1	D5704	C-DIODE	KDS4148U	1	223283R2

PCB1	D5704 or	C-DIODE	1SS352	(1)	223234R2
PCB1	D5704 or	C-DIODE	MA2J111	(1)	223279R2
PCB1	D5705	C-DIODE	KDS4148U	1	223283R2
PCB1	D5705 or	C-DIODE	1SS352	(1)	223234R2
PCB1	D5705 or	C-DIODE	MA2J111	(1)	223279R2
PCB1	D5706	C-DIODE	KDS4148U	1	223283R2
PCB1	D5706 or	C-DIODE	1SS352	(1)	223234R2
PCB1	D5706 or	C-DIODE	MA2J111	(1)	223279R2
PCB1	D5708	C-DIODE	KDS4148U	1	223283R2
PCB1	D5708 or	C-DIODE	1SS352	(1)	223234R2
PCB1	D5708 or	C-DIODE	MA2J111	(1)	223279R2
PCB1	D5709	DIODE	RL1N4003	1	22380260T
PCB1	D5714	C-DIODE	KDS4148U	1	223283R2
PCB1	D5714 or	C-DIODE	1SS352	(1)	223234R2
PCB1	D5714 or	C-DIODE	MA2J111	(1)	223279R2
PCB1	D5715	C-DIODE	KDS4148U	1	223283R2
PCB1	D5715 or	C-DIODE	1SS352	(1)	223234R2
PCB1	D5715 or	C-DIODE	MA2J111	(1)	223279R2
PCB1	D5716	C-DIODE	KDS4148U	1	223283R2
PCB1	D5716 or	C-DIODE	1SS352	(1)	223234R2
PCB1	D5716 or	C-DIODE	MA2J111	(1)	223279R2
PCB1	D5718	C-DIODE	KDS4148U	1	223283R2
PCB1	D5718 or	C-DIODE	1SS352	(1)	223234R2
PCB1	D5718 or	C-DIODE	MA2J111	(1)	223279R2
PCB1	D5719	DIODE	RL1N4003	1	22380260T
PCB1	D6000	C-DIODE	KDS4148U	1	223283R2
PCB1	D6000 or	C-DIODE	1SS352	(1)	223234R2
PCB1	D6000 or	C-DIODE	MA2J111	(1)	223279R2
PCB1	D6001	C-DIODE	KDS4148U	1	223283R2
PCB1	D6001 or	C-DIODE	1SS352	(1)	223234R2
PCB1	D6001 or	C-DIODE	MA2J111	(1)	223279R2
PCB1	D6002	C-DIODE	KDS4148U	1	223283R2
PCB1	D6002 or	C-DIODE	1SS352	(1)	223234R2

PCB1	D6002 or	C-DIODE	MA2J111	(1)	223279R2
PCB1	D6003	C-DIODE	KDS4148U	1	223283R2
PCB1	D6003 or	C-DIODE	1SS352	(1)	223234R2
PCB1	D6003 or	C-DIODE	MA2J111	(1)	223279R2
PCB1	D6004	C-DIODE	KDS4148U	1	223283R2
PCB1	D6004 or	C-DIODE	1SS352	(1)	223234R2
PCB1	D6004 or	C-DIODE	MA2J111	(1)	223279R2
PCB1	D6005	C-DIODE	KDS4148U	1	223283R2
PCB1	D6005 or	C-DIODE	1SS352	(1)	223234R2
PCB1	D6005 or	C-DIODE	MA2J111	(1)	223279R2
PCB1	D6006	C-DIODE	KDS4148U	1	223283R2
PCB1	D6006 or	C-DIODE	1SS352	(1)	223234R2
PCB1	D6006 or	C-DIODE	MA2J111	(1)	223279R2
PCB1	D6010	C-DIODE	KDS4148U	1	223283R2
PCB1	D6010 or	C-DIODE	1SS352	(1)	223234R2
PCB1	D6010 or	C-DIODE	MA2J111	(1)	223279R2
PCB1	D6011	C-DIODE	KDS4148U	1	223283R2
PCB1	D6011 or	C-DIODE	1SS352	(1)	223234R2
PCB1	D6011 or	C-DIODE	MA2J111	(1)	223279R2
PCB1	D6012	C-DIODE	KDS4148U	1	223283R2
PCB1	D6012 or	C-DIODE	1SS352	(1)	223234R2
PCB1	D6012 or	C-DIODE	MA2J111	(1)	223279R2
PCB1	D6013	C-DIODE	KDS4148U	1	223283R2
PCB1	D6013 or	C-DIODE	1SS352	(1)	223234R2
PCB1	D6013 or	C-DIODE	MA2J111	(1)	223279R2
PCB1	D6014	C-DIODE	KDS4148U	1	223283R2
PCB1	D6014 or	C-DIODE	1SS352	(1)	223234R2
PCB1	D6014 or	C-DIODE	MA2J111	(1)	223279R2
PCB1	D6015	C-DIODE	KDS4148U	1	223283R2
PCB1	D6015 or	C-DIODE	1SS352	(1)	223234R2
PCB1	D6015 or	C-DIODE	MA2J111	(1)	223279R2
PCB1	D6016	C-DIODE	KDS4148U	1	223283R2
PCB1	D6016 or	C-DIODE	1SS352	(1)	223234R2

PCB1	D6016 or	C-DIODE	MA2J111	(1)	223279R2
PCB1	D6701	C-DIODE	KDS4148U	1	223283R2
PCB1	D6701 or	C-DIODE	ISS352	(1)	223234R2
PCB1	D6701 or	C-DIODE	MA2J111	(1)	223279R2
PCB1	D6702	C-DIODE	KDS4148U	1	223283R2
PCB1	D6702 or	C-DIODE	ISS352	(1)	223234R2
PCB1	D6702 or	C-DIODE	MA2J111	(1)	223279R2
PCB1	D6703	ZENER D	UDZ3.3B	1	224490330R2
PCB1	D6703 or	ZENER D	UDZS3.3B	(1)	224550330R2
PCB1	D6704	ZENER D	UDZ3.3B	1	224490330R2
PCB1	D6704 or	ZENER D	UDZS3.3B	(1)	224550330R2
PCB1	D6901	DIODE	D10XB60H	1	22380337
PCB1	D6901A	HEAT SINK	RAD-196	1	27160545
PCB1	D6901C	SCREW	3P+10FN(3BC)	2	82143010GR
PCB1	D6902	C-DIODE	KDS4148U	1	223283R2
PCB1	D6902 or	C-DIODE	ISS352	(1)	223234R2
PCB1	D6902 or	C-DIODE	MA2J111	(1)	223279R2
PCB1	D6903	DIODE	D10XB60H	1	22380337
PCB1	D9001	DIODE	RL1N4003	1	22380260T
PCB1	D9002	DIODE	RL1N4003	1	22380260T
PCB1	D9003	DIODE	RL1N4003	1	22380260T
PCB1	D9004	DIODE	RL1N4003	1	22380260T
PCB1	C5000	TF C	ECQ-B50V-221K	1	374722215T
PCB1	C5001	TF C	ECQ-B50V-221K	1	374722215T
PCB1	C5002	TF C	ECQ-B50V-221K	1	374722215T
PCB1	C5003	TF C	ECQ-B50V-221K	1	374722215T
PCB1	C5004	TF C	ECQ-B50V-221K	1	374722215T
PCB1	C5005	TF C	ECQ-B50V-221K	1	374722215T
PCB1	C5006	TF C	ECQ-B50V-221K	1	374722215T
PCB1	C5010	UTSP C	CE04W50V 47M(UTSP)	1	397584707T
PCB1	C5011	UTSP C	CE04W50V 47M(UTSP)	1	397584707T
PCB1	C5012	UTSP C	CE04W50V 47M(UTSP)	1	397584707T
PCB1	C5013	UTSP C	CE04W50V 47M(UTSP)	1	397584707T

PCB1	C5014	UTSP C	CE04W50V 47M(UTSP)	1	397584707T
PCB1	C5015	UTSP C	CE04W50V 47M(UTSP)	1	397584707T
PCB1	C5016	UTSP C	CE04W50V 47M(UTSP)	1	397584707T
PCB1	C5020	UTSP C	CE04W50V-10M(UTSP)	1	397581007T
PCB1	C5021	UTSP C	CE04W50V-10M(UTSP)	1	397581007T
PCB1	C5022	UTSP C	CE04W50V-10M(UTSP)	1	397581007T
PCB1	C5023	UTSP C	CE04W50V-10M(UTSP)	1	397581007T
PCB1	C5024	UTSP C	CE04W50V-10M(UTSP)	1	397581007T
PCB1	C5025	UTSP C	CE04W50V-10M(UTSP)	1	397581007T
PCB1	C5026	UTSP C	CE04W50V-10M(UTSP)	1	397581007T
PCB1	C5040	UTSP C	CE04W25V-220M(UTSP)	1	397552217T
PCB1	C5041	UTSP C	CE04W25V-220M(UTSP)	1	397552217T
PCB1	C5042	UTSP C	CE04W25V-220M(UTSP)	1	397552217T
PCB1	C5043	UTSP C	CE04W25V-220M(UTSP)	1	397552217T
PCB1	C5044	UTSP C	CE04W25V-220M(UTSP)	1	397552217T
PCB1	C5045	UTSP C	CE04W25V-220M(UTSP)	1	397552217T
PCB1	C5046	UTSP C	CE04W25V-220M(UTSP)	1	397552217T
PCB1	C5050	UTSP C	CE04W50V 47M(UTSP)	1	397584707T
PCB1	C5051	UTSP C	CE04W50V 47M(UTSP)	1	397584707T
PCB1	C5052	UTSP C	CE04W50V 47M(UTSP)	1	397584707T
PCB1	C5053	UTSP C	CE04W50V 47M(UTSP)	1	397584707T
PCB1	C5054	UTSP C	CE04W50V 47M(UTSP)	1	397584707T
PCB1	C5055	UTSP C	CE04W50V 47M(UTSP)	1	397584707T
PCB1	C5056	UTSP C	CE04W50V 47M(UTSP)	1	397584707T
PCB1	C5080	CERA C	CC45SL50V-040C	1	345020401T
PCB1	C5081	CERA C	CC45SL50V-040C	1	345020401T
PCB1	C5082	CERA C	CC45SL50V-040C	1	345020401T
PCB1	C5083	CERA C	CC45SL50V-040C	1	345020401T
PCB1	C5084	CERA C	CC45SL50V-040C	1	345020401T
PCB1	C5085	CERA C	CC45SL50V-040C	1	345020401T
PCB1	C5086	CERA C	CC45SL50V-040C	1	345020401T
PCB1	C5090	TF C	ECQ-B50V-101K	1	374721015T
PCB1	C5091	TF C	ECQ-B50V-101K	1	374721015T

PCB1	C5092	TF C	ECQ-B50V-101K	1	374721015T
PCB1	C5093	TF C	ECQ-B50V-101K	1	374721015T
PCB1	C5094	TF C	ECQ-B50V-101K	1	374721015T
PCB1	C5095	TF C	ECQ-B50V-101K	1	374721015T
PCB1	C5096	TF C	ECQ-B50V-101K	1	374721015T
PCB1	C5100	VR C	CE04W100V-22M(VR)	1	394692207T
PCB1	C5101	VR C	CE04W100V-22M(VR)	1	394692207T
PCB1	C5102	VR C	CE04W100V-22M(VR)	1	394692207T
PCB1	C5103	VR C	CE04W100V-22M(VR)	1	394692207T
PCB1	C5104	VR C	CE04W100V-22M(VR)	1	394692207T
PCB1	C5105	VR C	CE04W100V-22M(VR)	1	394692207T
PCB1	C5106	VR C	CE04W100V-22M(VR)	1	394692207T
PCB1	C5110	VR C	CE04W100V-22M(VR)	1	394692207T
PCB1	C5111	VR C	CE04W100V-22M(VR)	1	394692207T
PCB1	C5112	VR C	CE04W100V-22M(VR)	1	394692207T
PCB1	C5113	VR C	CE04W100V-22M(VR)	1	394692207T
PCB1	C5114	VR C	CE04W100V-22M(VR)	1	394692207T
PCB1	C5115	VR C	CE04W100V-22M(VR)	1	394692207T
PCB1	C5116	VR C	CE04W100V-22M(VR)	1	394692207T
PCB1	C5503	TF C	ECQ-B50V-221K	1	374722215T
PCB1	C5504	TF C	ECQ-B50V-221K	1	374722215T
PCB1	C5507	C-CERA C	CC725CH1H-221J1	1	342102214R1
PCB1	C5508	C-CERA C	CC725CH1H-221J1	1	342102214R1
PCB1	C5513	C-CERA C	CC725CH1H-221J1	1	342102214R1
PCB1	C5514	C-CERA C	CC725CH1H-221J1	1	342102214R1
PCB1	C5517	C-CERA C	CC725CH1H-221J1	1	342102214R1
PCB1	C5518	C-CERA C	CC725CH1H-221J1	1	342102214R1
PCB1	C5519	TF C	ECQ-B50V-221K	1	374722215T
PCB1	C5520	TF C	ECQ-B50V-221K	1	374722215T
PCB1	C5521	C-CERA C	CC725CH1H-221J1	1	342102214R1
PCB1	C5522	C-CERA C	CC725CH1H-221J1	1	342102214R1
PCB1	C5523	C-CERA C	CC725CH1H-221J1	1	342102214R1
PCB1	C5524	TF C	ECQ-B50V-221K	1	374722215T

PCB1	C5525	C-CERA C	CC725CH1H-221J1	1	342102214R1
PCB1	C5526	C-CERA C	CC725CH1H-221J1	1	342102214R1
PCB1	C5531	C-CERA C	CC725CH1H-221J1	1	342102214R1
PCB1	C5551	UTSP C	CE04W25V-47M(UTSP)	1	397554707T
PCB1	C5552	UTSP C	CE04W25V-47M(UTSP)	1	397554707T
PCB1	C5553	UTSP C	CE04W25V-47M(UTSP)	1	397554707T
PCB1	C5554	UTSP C	CE04W25V-47M(UTSP)	1	397554707T
PCB1	C5555	UTSP C	CE04W25V-47M(UTSP)	1	397554707T
PCB1	C5556	UTSP C	CE04W25V-47M(UTSP)	1	397554707T
PCB1	C5557	UTSP C	CE04W25V-47M(UTSP)	1	397554707T
PCB1	C5558	UTSP C	CE04W25V-47M(UTSP)	1	397554707T
PCB1	C5559	TF C	ECQ-V50V-474J	1	374724744T
PCB1	C5560	TF C	ECQ-V50V-823J	1	374728234T
PCB1	C5561	TF C	ECQ-B50V-223J	1	374722234T
PCB1	C5562	TF C	ECQ-V50V-474J	1	374724744T
PCB1	C5563	TF C	ECQ-V50V-823J	1	374728234T
PCB1	C5564	TF C	ECQ-B50V-223J	1	374722234T
PCB1	C5565	UTSP C	CE04W25V-47M(UTSP)	1	397554707T
PCB1	C5566	UTSP C	CE04W25V-47M(UTSP)	1	397554707T
PCB1	C5569	UTSP C	CE04W25V-47M(UTSP)	1	397554707T
PCB1	C5570	UTSP C	CE04W25V-47M(UTSP)	1	397554707T
PCB1	C5571	UTSP C	CE04W25V-47M(UTSP)	1	397554707T
PCB1	C5572	UTSP C	CE04W25V-47M(UTSP)	1	397554707T
PCB1	C5573	UTSP C	CE04W25V-47M(UTSP)	1	397554707T
PCB1	C5574	UTSP C	CE04W25V-47M(UTSP)	1	397554707T
PCB1	C5575	UTSP C	CE04W25V-47M(UTSP)	1	397554707T
PCB1	C5576	UTSP C	CE04W25V-47M(UTSP)	1	397554707T
PCB1	C5590	C-CERA C	CC725CH1H-330J1	1	342103304R1
PCB1	C5591	C-CERA C	CC725CH1H-330J1	1	342103304R1
PCB1	C5600	UTSP C	CE04W25V-100M(UTSP)	1	397551017T
PCB1	C5601	UTSP C	CE04W25V-47M(UTSP)	1	397554707T
PCB1	C5602	UTSP C	CE04W25V-47M(UTSP)	1	397554707T
PCB1	C5603	UTSP C	CE04W25V-47M(UTSP)	1	397554707T

PCB1	C5604	UTSP C	CE04W25V-47M(UTSP)	1	397554707T
PCB1	C5605	UTSP C	CE04W25V-47M(UTSP)	1	397554707T
PCB1	C5606	UTSP C	CE04W25V-47M(UTSP)	1	397554707T
PCB1	C5607	UTSP C	CE04W25V-47M(UTSP)	1	397554707T
PCB1	C5630	UTSP C	CE04W25V-47M(UTSP)	1	397554707T
PCB1	C5631	C-CERA C	CC725CH1H-221J1	1	342102214R1
PCB1	C5632	TF C	ECQ-B50V-103J	1	374721034T
PCB1	C5666	UTSP C	CE04W25V-220M(UTSP)	1	397552217T
PCB1	C5667	UTSP C	CE04W25V-220M(UTSP)	1	397552217T
PCB1	C5670	UTSP C	CE04W50V-10M(UTSP)	1	397581007T
PCB1	C5671	UTSP C	CE04W50V-10M(UTSP)	1	397581007T
PCB1	C5672	UTSP C	CE04W25V-220M(UTSP)	1	397552217T
PCB1	C5673	UTSP C	CE04W25V-220M(UTSP)	1	397552217T
PCB1	C5674	UTSP C	CE04W16V-470M(UTSP)	1	397544717T
PCB1	C5675	UTSP C	CE04W16V-470M(UTSP)	1	397544717T
PCB1	C5704	C-CERA C	CC725CH1H-221J1	1	342102214R1
PCB1	C5705	C-CERA C	CC725CH1H-221J1	1	342102214R1
PCB1	C5706	C-CERA C	CC725CH1H-221J1	1	342102214R1
PCB1	C5708	C-CERA C	CK725B1H-103K1	1	332101035R1
PCB1	C5709	UTSP C	CE04W25V-47M(UTSP)	1	397554707T
PCB1	C5710	UTSP C	CE04W25V-47M(UTSP)	1	397554707T
PCB1	C6030	TF C	ECQ-V50V-473J	1	374724734T
PCB1	C6031	TF C	ECQ-V50V-473J	1	374724734T
PCB1	C6032	TF C	ECQ-V50V-473J	1	374724734T
PCB1	C6033	TF C	ECQ-V50V-473J	1	374724734T
PCB1	C6034	TF C	ECQ-V50V-473J	1	374724734T
PCB1	C6035	TF C	ECQ-V50V-473J	1	374724734T
PCB1	C6036	TF C	ECQ-V50V-473J	1	374724734T
PCB1	C6040	UTSP C	CE04W50V 47M(UTSP)	1	397584707T
PCB1	C6041	UTSP C	CE04W50V 47M(UTSP)	1	397584707T
PCB1	C6042	UTSP C	CE04W50V 47M(UTSP)	1	397584707T
PCB1	C6043	UTSP C	CE04W50V 47M(UTSP)	1	397584707T
PCB1	C6044	UTSP C	CE04W50V 47M(UTSP)	1	397584707T

PCB1	C6045	UTSP C	CE04W50V 47M(UTSP)	1	397584707T	
PCB1	C6046	UTSP C	CE04W50V 47M(UTSP)	1	397584707T	
PCB1	C6050	TF C	ECQ-B50V-103J	1	374721034T	
PCB1	C6051	TF C	ECQ-B50V-103J	1	374721034T	
PCB1	C6052	TF C	ECQ-B50V-103J	1	374721034T	
PCB1	C6053	TF C	ECQ-B50V-103J	1	374721034T	
PCB1	C6054	TF C	ECQ-B50V-103J	1	374721034T	
PCB1	C6055	TF C	ECQ-B50V-103J	1	374721034T	
PCB1	C6056	TF C	ECQ-B50V-103J	1	374721034T	
PCB1	C6076	TF C	ECQ-B50V-102J	1	374721024T	<MPP>
PCB1	C6077	TF C	ECQ-B50V-102J	1	374721024T	<MPP>
PCB1	C6086	TF C	ECQ-B50V-103J	1	374721034T	<MPP>
PCB1	C6087	TF C	ECQ-B50V-103J	1	374721034T	<MPP>
PCB1	C6630	C-CERA C	CK725F1E-104Z1	1	332161040R1	
PCB1	C6701	UTSP C	CE04W25V-100M(UTSP)	1	397551017T	
PCB1	C6703	C-CERA C	CK725F1H-104Z1	1	332151040R1	
PCB1	C6704	UTSP C	CE04W50V-1M(UTSP)	1	397580107T	
PCB1	C6706	UTSP C	CE04W50V-10M(UTSP)	1	397581007T	
PCB1	C6901	ELECT C	CE69W69V-10000MA	1	3504425	
PCB1	C6901A	IB CUSHION	W15 x 3t TAPE	1	28141585	
PCB1	C6902	ELECT C	CE69W69V-10000MA	1	3504425	
PCB1	C6902A	IB CUSHION	W15 x 3t TAPE	1	28141585	
PCB1	C6911	C-CERA C	CC725CH1H-102J1	1	342101024R1	
PCB1	C6912	TF C	ECQ-V50V-334J	1	374723344T	
PCB1	C6913	TF C	ECQ-V50V-334J	1	374723344T	
PCB1	C6915	TF C	ECQ-V50V-104J	1	374721044T	
PCB1	C6916	TF C	ECQ-V50V-104J	1	374721044T	
PCB1	C9001	MMT C	MMT50V-334J	1	375523344T	
PCB1	C9003	VR C	CE04W35V-1000M(VR)	1	394661027S	
PCB1	C9004	VR C	CE04W35V-470M(VR)	1	394664717T	
PCB1	R5000	CARBON R	R16J-1K	1	417341024T	
PCB1	R5001	CARBON R	R16J-1K	1	417341024T	
PCB1	R5002	CARBON R	R16J-1K	1	417341024T	

PCB1	R5003	CARBON R	R16J-1K	1	417341024T
PCB1	R5004	CARBON R	R16J-1K	1	417341024T
PCB1	R5005	CARBON R	R16J-1K	1	417341024T
PCB1	R5006	CARBON R	R16J-1K	1	417341024T
PCB1	R5010	CARBON R	R16J-56K	1	417345634T
PCB1	R5011	CARBON R	R16J-56K	1	417345634T
PCB1	R5012	CARBON R	R16J-56K	1	417345634T
PCB1	R5013	CARBON R	R16J-56K	1	417345634T
PCB1	R5014	CARBON R	R16J-56K	1	417345634T
PCB1	R5015	CARBON R	R16J-56K	1	417345634T
PCB1	R5016	CARBON R	R16J-56K	1	417345634T
PCB1	R5020	CARBON R	R16J-330	1	417343314T
PCB1	R5021	CARBON R	R16J-330	1	417343314T
PCB1	R5022	CARBON R	R16J-330	1	417343314T
PCB1	R5023	CARBON R	R16J-330	1	417343314T
PCB1	R5024	CARBON R	R16J-330	1	417343314T
PCB1	R5025	CARBON R	R16J-330	1	417343314T
PCB1	R5026	CARBON R	R16J-330	1	417343314T
PCB1	R5030	CARBON R	R16J-120K	1	417341244T
PCB1	R5031	CARBON R	R16J-120K	1	417341244T
PCB1	R5032	CARBON R	R16J-120K	1	417341244T
PCB1	R5033	CARBON R	R16J-120K	1	417341244T
PCB1	R5034	CARBON R	R16J-120K	1	417341244T
PCB1	R5035	CARBON R	R16J-120K	1	417341244T
PCB1	R5036	CARBON R	R16J-120K	1	417341244T
PCB1	R5040	CARBON R	R16J-2.2K	1	417342224T
PCB1	R5041	CARBON R	R16J-2.2K	1	417342224T
PCB1	R5042	CARBON R	R16J-2.2K	1	417342224T
PCB1	R5043	CARBON R	R16J-2.2K	1	417342224T
PCB1	R5044	CARBON R	R16J-2.2K	1	417342224T
PCB1	R5045	CARBON R	R16J-2.2K	1	417342224T
PCB1	R5046	CARBON R	R16J-2.2K	1	417342224T
PCB1	R5050	CARBON R	R16J-4.7K	1	417344724T

PCB1	R5051	CARBON R	R16J-4.7K	1	417344724T
PCB1	R5052	CARBON R	R16J-4.7K	1	417344724T
PCB1	R5053	CARBON R	R16J-4.7K	1	417344724T
PCB1	R5054	CARBON R	R16J-4.7K	1	417344724T
PCB1	R5055	CARBON R	R16J-4.7K	1	417344724T
PCB1	R5056	CARBON R	R16J-4.7K	1	417344724T
PCB1	R5060	CARBON R	R16J-1.2K	1	417341224T
PCB1	R5061	CARBON R	R16J-1.2K	1	417341224T
PCB1	R5062	CARBON R	R16J-1.2K	1	417341224T
PCB1	R5063	CARBON R	R16J-1.2K	1	417341224T
PCB1	R5064	CARBON R	R16J-1.2K	1	417341224T
PCB1	R5065	CARBON R	R16J-1.2K	1	417341224T
PCB1	R5066	CARBON R	R16J-1.2K	1	417341224T
PCB1	R5080	CARBON R	R16J-470	1	417344714T
PCB1	R5081	CARBON R	R16J-470	1	417344714T
PCB1	R5082	CARBON R	R16J-470	1	417344714T
PCB1	R5083	CARBON R	R16J-470	1	417344714T
PCB1	R5084	CARBON R	R16J-470	1	417344714T
PCB1	R5085	CARBON R	R16J-470	1	417344714T
PCB1	R5086	CARBON R	R16J-470	1	417344714T
PCB1	R5090	CARBON R	R16J-100K	1	417341044T
PCB1	R5091	CARBON R	R16J-100K	1	417341044T
PCB1	R5092	CARBON R	R16J-100K	1	417341044T
PCB1	R5093	CARBON R	R16J-100K	1	417341044T
PCB1	R5094	CARBON R	R16J-100K	1	417341044T
PCB1	R5095	CARBON R	R16J-100K	1	417341044T
PCB1	R5096	CARBON R	R16J-100K	1	417341044T
PCB1	R5100	CARBON R	R16J-100K	1	417341044T
PCB1	R5101	CARBON R	R16J-100K	1	417341044T
PCB1	R5102	CARBON R	R16J-100K	1	417341044T
PCB1	R5103	CARBON R	R16J-100K	1	417341044T
PCB1	R5104	CARBON R	R16J-100K	1	417341044T
PCB1	R5105	CARBON R	R16J-100K	1	417341044T

PCB1	R5106	CARBON R	R16J-100K	1	417341044T
PCB1	R5110	CARBON R	R16J-1K	1	417341024T
PCB1	R5111	CARBON R	R16J-1K	1	417341024T
PCB1	R5112	CARBON R	R16J-1K	1	417341024T
PCB1	R5113	CARBON R	R16J-1K	1	417341024T
PCB1	R5114	CARBON R	R16J-1K	1	417341024T
PCB1	R5115	CARBON R	R16J-1K	1	417341024T
PCB1	R5116	CARBON R	R16J-1K	1	417341024T
PCB1	R5130	CARBON R	R16J-22K	1	417342234T
PCB1	R5131	CARBON R	R16J-22K	1	417342234T
PCB1	R5132	CARBON R	R16J-22K	1	417342234T
PCB1	R5133	CARBON R	R16J-22K	1	417342234T
PCB1	R5134	CARBON R	R16J-22K	1	417342234T
PCB1	R5135	CARBON R	R16J-22K	1	417342234T
PCB1	R5136	CARBON R	R16J-22K	1	417342234T
PCB1	R5160	NF CARBON R	R25J-150	1	415471514T
PCB1	R5161	NF CARBON R	R25J-150	1	415471514T
PCB1	R5162	NF CARBON R	R25J-150	1	415471514T
PCB1	R5163	NF CARBON R	R25J-150	1	415471514T
PCB1	R5164	NF CARBON R	R25J-150	1	415471514T
PCB1	R5165	NF CARBON R	R25J-150	1	415471514T
PCB1	R5166	NF CARBON R	R25J-150	1	415471514T
PCB1	R5170	NF CARBON R	R25J-150	1	415471514T
PCB1	R5171	NF CARBON R	R25J-150	1	415471514T
PCB1	R5172	NF CARBON R	R25J-150	1	415471514T
PCB1	R5173	NF CARBON R	R25J-150	1	415471514T
PCB1	R5174	NF CARBON R	R25J-150	1	415471514T
PCB1	R5175	NF CARBON R	R25J-150	1	415471514T
PCB1	R5176	NF CARBON R	R25J-150	1	415471514T
PCB1	R5180	NF CARBON R	R25J-10	1	415471004T
PCB1	R5181	NF CARBON R	R25J-10	1	415471004T
PCB1	R5182	NF CARBON R	R25J-10	1	415471004T
PCB1	R5183	NF CARBON R	R25J-10	1	415471004T

PCB1	R5184	NF CARBON R	R25J-10	1	415471004T
PCB1	R5185	NF CARBON R	R25J-10	1	415471004T
PCB1	R5186	NF CARBON R	R25J-10	1	415471004T
PCB1	R5190	NF CARBON R	R25J-10	1	415471004T
PCB1	R5191	NF CARBON R	R25J-10	1	415471004T
PCB1	R5192	NF CARBON R	R25J-10	1	415471004T
PCB1	R5193	NF CARBON R	R25J-10	1	415471004T
PCB1	R5194	NF CARBON R	R25J-10	1	415471004T
PCB1	R5195	NF CARBON R	R25J-10	1	415471004T
PCB1	R5196	NF CARBON R	R25J-10	1	415471004T
PCB1	R5200	CARBON R	R16J-22K	1	417342234T
PCB1	R5201	CARBON R	R16J-22K	1	417342234T
PCB1	R5202	CARBON R	R16J-22K	1	417342234T
PCB1	R5203	CARBON R	R16J-22K	1	417342234T
PCB1	R5204	CARBON R	R16J-22K	1	417342234T
PCB1	R5205	CARBON R	R16J-22K	1	417342234T
PCB1	R5206	CARBON R	R16J-22K	1	417342234T
PCB1	R5230	CARBON R	R16J-120K	1	417341244T
PCB1	R5231	CARBON R	R16J-120K	1	417341244T
PCB1	R5232	CARBON R	R16J-120K	1	417341244T
PCB1	R5233	CARBON R	R16J-120K	1	417341244T
PCB1	R5234	CARBON R	R16J-120K	1	417341244T
PCB1	R5235	CARBON R	R16J-120K	1	417341244T
PCB1	R5236	CARBON R	R16J-120K	1	417341244T
PCB1	R5500	C-CARBON R	RN72K1J-331JE	1	435033314R1
PCB1	R5503	C-CARBON R	RN72K1J-331JE	1	435033314R1
PCB1	R5504	C-CARBON R	RN72K1J-331JE	1	435033314R1
PCB1	R5505	C-CARBON R	RN72K1J-222JE	1	435032224R1
PCB1	R5506	C-CARBON R	RN72K1J-222JE	1	435032224R1
PCB1	R5507	C-CARBON R	RN72K1J-331JE	1	435033314R1
PCB1	R5508	C-CARBON R	RN72K1J-331JE	1	435033314R1
PCB1	R5513	C-CARBON R	RN72K1J-331JE	1	435033314R1
PCB1	R5514	C-CARBON R	RN72K1J-331JE	1	435033314R1

PCB1	R5515	C-CARBON R	RN72K1J-222JE	1	435032224R1
PCB1	R5516	C-CARBON R	RN72K1J-222JE	1	435032224R1
PCB1	R5517	C-CARBON R	RN72K1J-331JE	1	435033314R1
PCB1	R5518	C-CARBON R	RN72K1J-331JE	1	435033314R1
PCB1	R5519	C-CARBON R	RN72K1J-331JE	1	435033314R1
PCB1	R5520	C-CARBON R	RN72K1J-331JE	1	435033314R1
PCB1	R5521	C-CARBON R	RN72K1J-331JE	1	435033314R1
PCB1	R5522	C-CARBON R	RN72K1J-331JE	1	435033314R1
PCB1	R5523	C-CARBON R	RN72K1J-331JE	1	435033314R1
PCB1	R5524	C-CARBON R	RN72K1J-331JE	1	435033314R1
PCB1	R5525	C-CARBON R	RN72K1J-331JE	1	435033314R1
PCB1	R5526	C-CARBON R	RN72K1J-331JE	1	435033314R1
PCB1	R5531	C-CARBON R	RN72K1J-101JE	1	435031014R1
PCB1	R5541	C-CARBON R	RN72K1J-224JE	1	435032244R1
PCB1	R5542	C-CARBON R	RN72K1J-224JE	1	435032244R1
PCB1	R5543	C-CARBON R	RN72K1J-224JE	1	435032244R1
PCB1	R5544	C-CARBON R	RN72K1J-224JE	1	435032244R1
PCB1	R5545	C-CARBON R	RN72K1J-224JE	1	435032244R1
PCB1	R5546	C-CARBON R	RN72K1J-224JE	1	435032244R1
PCB1	R5547	C-CARBON R	RN72K1J-224JE	1	435032244R1
PCB1	R5548	C-CARBON R	RN72K1J-224JE	1	435032244R1
PCB1	R5553	C-CARBON R	RN72K1J-224JE	1	435032244R1
PCB1	R5554	C-CARBON R	RN72K1J-224JE	1	435032244R1
PCB1	R5555	C-CARBON R	RN72K1J-224JE	1	435032244R1
PCB1	R5556	C-CARBON R	RN72K1J-224JE	1	435032244R1
PCB1	R5557	C-CARBON R	RN72K1J-224JE	1	435032244R1
PCB1	R5558	C-CARBON R	RN72K1J-224JE	1	435032244R1
PCB1	R5559	C-CARBON R	RN72K1J-224JE	1	435032244R1
PCB1	R5560	C-CARBON R	RN72K1J-224JE	1	435032244R1
PCB1	R5561	C-CARBON R	RN72K1J-224JE	1	435032244R1
PCB1	R5562	C-CARBON R	RN72K1J-224JE	1	435032244R1
PCB1	R5563	C-CARBON R	RN72K1J-224JE	1	435032244R1
PCB1	R5564	C-CARBON R	RN72K1J-224JE	1	435032244R1

PCB1	R5565	C-CARBON R	RN72K1J-224JE	1	435032244R1
PCB1	R5566	C-CARBON R	RN72K1J-224JE	1	435032244R1
PCB1	R5571	C-CARBON R	RN72K1J-223JE	1	435032234R1
PCB1	R5575	C-CARBON R	RN72K1J-224JE	1	435032244R1
PCB1	R5576	C-CARBON R	RN72K1J-224JE	1	435032244R1
PCB1	R5577	C-CARBON R	RN72K1J-103JE	1	435031034R1
PCB1	R5578	C-CARBON R	RN72K1J-103JE	1	435031034R1
PCB1	R5579	C-CARBON R	RN72K1J-224JE	1	435032244R1
PCB1	R5585	C-CARBON R	RN72K1J-182JE	1	435031824R1
PCB1	R5586	C-CARBON R	RN72K1J-182JE	1	435031824R1
PCB1	R5587	C-CARBON R	RN72K1J-103JE	1	435031034R1
PCB1	R5588	C-CARBON R	RN72K1J-103JE	1	435031034R1
PCB1	R5589	CARBON R	R16J-1K	1	417341024T
PCB1	R5590	C-CARBON R	RN72K1J-103JE	1	435031034R1
PCB1	R5591	C-CARBON R	RN72K1J-103JE	1	435031034R1
PCB1	R5592	C-CARBON R	RN72K1J-471JE	1	435034714R1
PCB1	R5593	C-CARBON R	RN72K1J-122JE	1	435031224R1
PCB1	R5594	C-CARBON R	RN72K1J-103JE	1	435031034R1
PCB1	R5595	C-CARBON R	RN72K1J-103JE	1	435031034R1
PCB1	R5596	C-CARBON R	RN72K1J-471JE	1	435034714R1
PCB1	R5597	C-CARBON R	RN72K1J-122JE	1	435031224R1
PCB1	R5598	C-CARBON R	RN72K1J-103JE	1	435031034R1
PCB1	R5599	C-CARBON R	RN72K1J-103JE	1	435031034R1
PCB1	R5600	C-CARBON R	RN72K1J-224JE	1	435032244R1
PCB1	R5601	C-CARBON R	RN72K1J-224JE	1	435032244R1
PCB1	R5602	C-CARBON R	RN72K1J-224JE	1	435032244R1
PCB1	R5603	C-CARBON R	RN72K1J-224JE	1	435032244R1
PCB1	R5604	C-CARBON R	RN72K1J-224JE	1	435032244R1
PCB1	R5605	C-CARBON R	RN72K1J-224JE	1	435032244R1
PCB1	R5606	C-CARBON R	RN72K1J-224JE	1	435032244R1
PCB1	R5607	C-CARBON R	RN72K1J-224JE	1	435032244R1
PCB1	R5610	C-CARBON R	RN72K1J-271JE	1	435032714R1
PCB1	R5611	C-CARBON R	RN72K1J-222JE	1	435032224R1

PCB1	R5612	C-CARBON R	RN72K1J-222JE	1	435032224R1
PCB1	R5613	C-CARBON R	RN72K1J-222JE	1	435032224R1
PCB1	R5614	C-CARBON R	RN72K1J-222JE	1	435032224R1
PCB1	R5615	C-CARBON R	RN72K1J-222JE	1	435032224R1
PCB1	R5616	C-CARBON R	RN72K1J-222JE	1	435032224R1
PCB1	R5617	C-CARBON R	RN72K1J-222JE	1	435032224R1
PCB1	R5620	C-CARBON R	RN72K1J-101JE	1	435031014R1
PCB1	R5621	C-CARBON R	RN72K1J-000JE	1	435030004R1
PCB1	R5622	C-CARBON R	RN72K1J-000JE	1	435030004R1
PCB1	R5623	C-CARBON R	RN72K1J-000JE	1	435030004R1
PCB1	R5624	C-CARBON R	RN72K1J-000JE	1	435030004R1
PCB1	R5625	C-CARBON R	RN72K1J-000JE	1	435030004R1
PCB1	R5626	C-CARBON R	RN72K1J-000JE	1	435030004R1
PCB1	R5627	C-CARBON R	RN72K1J-000JE	1	435030004R1
PCB1	R5630	C-CARBON R	RN72K1J-221JE	1	435032214R1
PCB1	R5631	C-CARBON R	RN72K1J-473JE	1	435034734R1
PCB1	R5632	C-CARBON R	RN72K1J-153JE	1	435031534R1
PCB1	R5633	C-CARBON R	RN72K1J-122JE	1	435031224R1
PCB1	R5634	C-CARBON R	RN72K1J-103JE	1	435031034R1
PCB1	R5660	METAL R	RNU1WCJ-2.2	1	453630224T
PCB1	R5661	METAL R	RNU1WCJ-2.2	1	453630224T
PCB1	R5666	CARBON R	R16J-22	1	417342204T
PCB1	R5667	CARBON R	R16J-22	1	417342204T
PCB1	R5670	METAL O R	RS2WBJ-10	1	441721004F
PCB1	R5671	METAL O R	RS2WBJ-27	1	441722704F
PCB1	R5672	METAL O R	RS2WBJ-10	1	441721004F
PCB1	R5673	METAL O R	RS2WBJ-27	1	441722704F
PCB1	R5674	METAL O R	RS1WBJ-68	1	443626804T
PCB1	R5675	METAL O R	RS1WBJ-68	1	443626804T
PCB1	R5677	METAL O R	RS2WBJ-15	1	441721504F
PCB1	R5678	METAL O R	RS2WBJ-15	1	441721504F
PCB1	R5681	C-CARBON R	RN72K1J-224JE	1	435032244R1
PCB1	R5683	METAL O R	RS1WBJ-68	1	443626804T

PCB1	R5684	METAL O R	RS1WBJ-68	1	443626804T
PCB1	R5689	C-CARBON R	RN72K1J-224JE	1	435032244R1
PCB1	R5690	C-CARBON R	RN72K1J-224JE	1	435032244R1
PCB1	R5691	C-CARBON R	RN72K1J-224JE	1	435032244R1
PCB1	R5692	C-CARBON R	RN72K1J-224JE	1	435032244R1
PCB1	R5693	C-CARBON R	RN72K1J-224JE	1	435032244R1
PCB1	R5694	C-CARBON R	RN72K1J-224JE	1	435032244R1
PCB1	R5695	C-CARBON R	RN72K1J-224JE	1	435032244R1
PCB1	R5814	C-CARBON R	RN72K1J-000JE	1	435030004R1
PCB1	R5820	C-CARBON R	RN72K1J-000JE	1	435030004R1
PCB1	R5822	C-CARBON R	RN72K1J-000JE	1	435030004R1
PCB1	R5823	C-CARBON R	RN72K1J-000JE	1	435030004R1
PCB1	R5824	C-CARBON R	RN72K1J-000JE	1	435030004R1
PCB1	R5825	C-CARBON R	RN72K1J-000JE	1	435030004R1
PCB1	R5826	C-CARBON R	RN72K1J-000JE	1	435030004R1
PCB1	R6000	CARBON R	R16J-5.6K	1	417345624T
PCB1	R6001	CARBON R	R16J-5.6K	1	417345624T
PCB1	R6002	CARBON R	R16J-5.6K	1	417345624T
PCB1	R6003	CARBON R	R16J-5.6K	1	417345624T
PCB1	R6004	CARBON R	R16J-5.6K	1	417345624T
PCB1	R6005	CARBON R	R16J-5.6K	1	417345624T
PCB1	R6006	CARBON R	R16J-5.6K	1	417345624T
PCB1	R6010	CARBON R	R16J-3.9K	1	417343924T
PCB1	R6011	CARBON R	R16J-3.9K	1	417343924T
PCB1	R6012	CARBON R	R16J-3.9K	1	417343924T
PCB1	R6013	CARBON R	R16J-3.9K	1	417343924T
PCB1	R6014	CARBON R	R16J-3.9K	1	417343924T
PCB1	R6015	CARBON R	R16J-3.9K	1	417343924T
PCB1	R6016	CARBON R	R16J-3.9K	1	417343924T
PCB1	R6020	NF CARBON R	R25J-2.2	1	415470224T
PCB1	R6021	NF CARBON R	R25J-2.2	1	415470224T
PCB1	R6022	NF CARBON R	R25J-2.2	1	415470224T
PCB1	R6023	NF CARBON R	R25J-2.2	1	415470224T

PCB1	R6024	NF CARBON R	R25J-2.2	1	415470224T
PCB1	R6025	NF CARBON R	R25J-2.2	1	415470224T
PCB1	R6026	NF CARBON R	R25J-2.2	1	415470224T
PCB1	R6030	CARBON R	R16J-470	1	417344714T
PCB1	R6031	CARBON R	R16J-470	1	417344714T
PCB1	R6032	CARBON R	R16J-470	1	417344714T
PCB1	R6033	CARBON R	R16J-470	1	417344714T
PCB1	R6034	CARBON R	R16J-470	1	417344714T
PCB1	R6035	CARBON R	R16J-470	1	417344714T
PCB1	R6036	CARBON R	R16J-470	1	417344714T
PCB1	R6040	TRIM R	N06HR2KBC	1	5210390T
PCB1	R6041	TRIM R	N06HR2KBC	1	5210390T
PCB1	R6042	TRIM R	N06HR2KBC	1	5210390T
PCB1	R6043	TRIM R	N06HR2KBC	1	5210390T
PCB1	R6044	TRIM R	N06HR2KBC	1	5210390T
PCB1	R6045	TRIM R	N06HR2KBC	1	5210390T
PCB1	R6046	TRIM R	N06HR2KBC	1	5210390T
PCB1	R6050	CARBON R	R16J-3.3K	1	417343324T
PCB1	R6051	CARBON R	R16J-3.3K	1	417343324T
PCB1	R6052	CARBON R	R16J-3.3K	1	417343324T
PCB1	R6053	CARBON R	R16J-3.3K	1	417343324T
PCB1	R6054	CARBON R	R16J-3.3K	1	417343324T
PCB1	R6055	CARBON R	R16J-3.3K	1	417343324T
PCB1	R6056	CARBON R	R16J-3.3K	1	417343324T
PCB1	R6070	NF CARBON R	R25J-120	1	415471214T
PCB1	R6071	NF CARBON R	R25J-120	1	415471214T
PCB1	R6072	NF CARBON R	R25J-120	1	415471214T
PCB1	R6073	NF CARBON R	R25J-120	1	415471214T
PCB1	R6074	NF CARBON R	R25J-120	1	415471214T
PCB1	R6075	NF CARBON R	R25J-120	1	415471214T
PCB1	R6076	NF CARBON R	R25J-120	1	415471214T
PCB1	R6080	NF CARBON R	R25J-0.22	1	415472294T
PCB1	R6081	NF CARBON R	R25J-0.22	1	415472294T

PCB1	R6082	NF CARBON R	R25J-0.22	1	415472294T
PCB1	R6083	NF CARBON R	R25J-0.22	1	415472294T
PCB1	R6084	NF CARBON R	R25J-0.22	1	415472294T
PCB1	R6085	NF CARBON R	R25J-0.22	1	415472294T
PCB1	R6086	NF CARBON R	R25J-0.22	1	415472294T
PCB1	R6090	NF CARBON R	R25J-0.22	1	415472294T
PCB1	R6091	NF CARBON R	R25J-0.22	1	415472294T
PCB1	R6092	NF CARBON R	R25J-0.22	1	415472294T
PCB1	R6093	NF CARBON R	R25J-0.22	1	415472294T
PCB1	R6094	NF CARBON R	R25J-0.22	1	415472294T
PCB1	R6095	NF CARBON R	R25J-0.22	1	415472294T
PCB1	R6096	NF CARBON R	R25J-0.22	1	415472294T
PCB1	R6100	METAL PR	MPR2W+2W 0R22	1	4000234
PCB1	R6101	METAL PR	MPR2W+2W 0R22	1	4000234
PCB1	R6102	METAL PR	MPR2W+2W 0R22	1	4000234
PCB1	R6103	METAL PR	MPR2W+2W 0R22	1	4000234
PCB1	R6104	METAL PR	MPR2W+2W 0R22	1	4000234
PCB1	R6105	METAL PR	MPR2W+2W 0R22	1	4000234
PCB1	R6106	METAL PR	MPR2W+2W 0R22	1	4000234
PCB1	R6130	METAL R	RNU1WCJ-8.2	1	453630824T
PCB1	R6131	METAL R	RNU1WCJ-8.2	1	453630824T
PCB1	R6132	METAL R	RNU1WCJ-8.2	1	453630824T
PCB1	R6133	METAL R	RNU1WCJ-8.2	1	453630824T
PCB1	R6134	METAL R	RNU1WCJ-8.2	1	453630824T
PCB1	R6135	METAL R	RNU1WCJ-8.2	1	453630824T
PCB1	R6136	METAL R	RNU1WCJ-8.2	1	453630824T
PCB1	R6140	C-CARBON R	RN72K1J-223JE	1	435032234R1
PCB1	R6141	C-CARBON R	RN72K1J-223JE	1	435032234R1
PCB1	R6142	C-CARBON R	RN72K1J-223JE	1	435032234R1
PCB1	R6143	C-CARBON R	RN72K1J-223JE	1	435032234R1
PCB1	R6144	C-CARBON R	RN72K1J-223JE	1	435032234R1
PCB1	R6145	C-CARBON R	RN72K1J-223JE	1	435032234R1
PCB1	R6146	C-CARBON R	RN72K1J-223JE	1	435032234R1

PCB1	R6150	C-CARBON R	RN72K1J-123JE	1	435031234R1
PCB1	R6151	C-CARBON R	RN72K1J-123JE	1	435031234R1
PCB1	R6152	C-CARBON R	RN72K1J-123JE	1	435031234R1
PCB1	R6153	C-CARBON R	RN72K1J-123JE	1	435031234R1
PCB1	R6154	C-CARBON R	RN72K1J-123JE	1	435031234R1
PCB1	R6155	C-CARBON R	RN72K1J-123JE	1	435031234R1
PCB1	R6156	C-CARBON R	RN72K1J-123JE	1	435031234R1
PCB1	R6160	CARBON R	R16J-33K	1	417343334T
PCB1	R6161	CARBON R	R16J-33K	1	417343334T
PCB1	R6162	CARBON R	R16J-33K	1	417343334T
PCB1	R6163	CARBON R	R16J-33K	1	417343334T
PCB1	R6164	CARBON R	R16J-33K	1	417343334T
PCB1	R6165	CARBON R	R16J-33K	1	417343334T
PCB1	R6166	CARBON R	R16J-33K	1	417343334T
PCB1	R6170	CARBON R	R16J-47K	1	417344734T
PCB1	R6171	CARBON R	R16J-47K	1	417344734T
PCB1	R6172	CARBON R	R16J-47K	1	417344734T
PCB1	R6173	CARBON R	R16J-47K	1	417344734T
PCB1	R6174	CARBON R	R16J-47K	1	417344734T
PCB1	R6175	CARBON R	R16J-47K	1	417344734T
PCB1	R6176	CARBON R	R16J-47K	1	417344734T
PCB1	R6180	CARBON R	R16J-47K	1	417344734T
PCB1	R6181	CARBON R	R16J-47K	1	417344734T
PCB1	R6182	CARBON R	R16J-47K	1	417344734T
PCB1	R6183	CARBON R	R16J-47K	1	417344734T
PCB1	R6184	CARBON R	R16J-47K	1	417344734T
PCB1	R6185	CARBON R	R16J-47K	1	417344734T
PCB1	R6186	CARBON R	R16J-47K	1	417344734T
PCB1	R6190	C-CARBON R	RN72K1J-224JE	1	435032244R1
PCB1	R6191	C-CARBON R	RN72K1J-224JE	1	435032244R1
PCB1	R6192	C-CARBON R	RN72K1J-224JE	1	435032244R1
PCB1	R6193	C-CARBON R	RN72K1J-224JE	1	435032244R1
PCB1	R6194	C-CARBON R	RN72K1J-224JE	1	435032244R1

PCB1	R6195	C-CARBON R	RN72K1J-224JE	1	435032244R1	
PCB1	R6196	C-CARBON R	RN72K1J-224JE	1	435032244R1	
PCB1	R6197	METAL O R	RS1WBJ-100	1	443621014T	
PCB1	R6701	C-CARBON R	RN72K1J-223JE	1	435032234R1	
PCB1	R6702	C-CARBON R	RN72K1J-103JE	1	435031034R1	
PCB1	R6704	C-CARBON R	RN72K1J-473JE	1	435034734R1	
PCB1	R6706	C-CARBON R	RN72K1J-224JE	1	435032244R1	
PCB1	R6708	C-CARBON R	RN72K1J-333JE	1	435033334R1	
PCB1	R6709	C-CARBON R	RN72K1J-562JE	1	435035624R1	
PCB1	R6710	C-CARBON R	RN72K1J-472JE	1	435034724R1	
PCB1	R6902	C-CARBON R	RN72K1J-102JE	1	435031024R1	
PCB1	R6903	C-CARBON R	RN72K1J-473JE	1	435034734R1	
PCB1	RL6901	RELAY	NRL-1P10A-DC12-140	1	25065584	!
PCB1	RL6901 or	RELAY	NRL-1P10A-DC12-143	(1)	25065588	!
PCB1	RL6902	RELAY	NRL-1P10A-DC12-140	1	25065584	!
PCB1	RL6902 or	RELAY	NRL-1P10A-DC12-143	(1)	25065588	!
PCB1	P302	PLUG	NPLG-15P0970	1	25056020	
PCB1	P303	PLUG	NPLG-15P0970	1	25056020	
PCB1	P304	PLUG	NPLG-3P0958	1	25056008	
PCB1	P5505	TRM-423(SCREW)	NEJITANSI ST3	1	25060495	
PCB1	P6080	PLUG	NPLG-2P130	1	25055146	
PCB1	P6081	PLUG	NPLG-2P130	1	25055146	
PCB1	P6082	PLUG	NPLG-2P130	1	25055146	
PCB1	P6083	PLUG	NPLG-2P130	1	25055146	
PCB1	P6084	PLUG	NPLG-2P130	1	25055146	
PCB1	P6085	PLUG	NPLG-2P130	1	25055146	
PCB1	P6086	PLUG	NPLG-2P130	1	25055146	
PCB1	P6101	CLAMP	WS-2NS	1	27300833	
PCB1	P6602	TRM	NTM-4PDML422	1	25060494	
PCB1	P6900	CRIMP AS	CRIMP AS	1	20799162UL	
PCB1	P6901	CRIMP AS	CRIMP AS	1	2069925226UL	
PCB1	P6902	CRIMP AS	CRIMP AS	1	2069925189UL	
PCB1	P6903	CRIMP AS	CRIMP AS	1	20799163UL	

PCB1	P6904	CRIMP AS	CRIMP AS	1	20799164UL	
PCB1	P6911	RETAINER	(BUS)	1	27142022	
PCB1	P6991	TRM-423(SCREW)	NEJITANSI ST3	1	25060495	
PCB1	P7900	ST JACK	MSJ-035-22	1	25045887	
PCB1	P7900 or	JACK	YKB21-5130	(1)	25045387	
PCB1	P7902	PIN JACK	NPJ-6PDWWRRRR561	1	25045779	
PCB1	P7902 or	PIN JACK	NPJ-6PDBL159	(1)	25045300	
PCB1	P7904	PIN JACK	NPJ-6PDWWRRRR561	1	25045779	
PCB1	P7904 or	PIN JACK	NPJ-6PDBL159	(1)	25045300	
PCB1	P7905	PIN JACK	NPJ-4PDWLRE642	1	25045866	
PCB1	P7906	PIN JACK	NPJ-4PDGNPT643	1	25045867	
PCB1	P7908	PIN JACK	NPJ-1PDP555	1	25045773	
PCB1	F6901C	FUSE HOL	NSCT-1P2031	1	25052133T	!
PCB1	F6901D	FUSE HOL	NSCT-1P2031	1	25052133T	!
PCB1	F6902C	FUSE HOL	NSCT-1P2031	1	25052133T	!
PCB1	F6902D	FUSE HOL	NSCT-1P2031	1	25052133T	!
PCB1	J5500	PVC	1007#24 .2/7HAND B	1	---	NSP
PCB1	J5500 or	PVC	1007#24 .2/7HAND R	(1)	---	NSP
PCB1	JL6402	JUMPER LEAD	JL3 300 B	1	---	NSP
PCB1	JL6402A	WIRE HOL	NSCT-3P874	1	25051087	
PCB1	JL6600	JUMPER LEAD	JL7 250 H	1	---	NSP
PCB1	JL6600A	WIRE HOL	NSCT-7P898	1	25051111	
PCB1	JL6603	JUMPER LEAD	JL9 200 H	1	---	NSP
PCB1	JL6603A	WIRE HOL	NSCT-9P900	1	25051113	
PCB1	JL6604	JUMPER LEAD	JL5 200 H	1	---	NSP
PCB1	JL6604A	WIRE HOL	NSCT-5P896	1	25051109	
PCB1	JL6952	JUMPER LEAD	JL5 150 H	1	---	NSP
PCB1	JL6952A	WIRE HOL	NSCT-5P896	1	25051109	
PCB1	JL6952B	WIRE HOL	NSCT-5P896	1	25051109	
PCB2	U10	DISPLAY PC BOARD (NADIS-9430-1L/ 1M)				
PCB2	U11	SWITCH PC BOARD (NADIS-9431-1L/ 1M)				
PCB2	U12	POWER SUPPLY PC BOARD (NAPS-9432-1L/ 1M)				

PCB2	U13	TRANS. SEC. TERMINAL PC BOARD (NAPS-9433-1L/ 1M)				
PCB2	U14	HEADPHONE JACK PC BOARD (NAETC-9435-1L/ 1M)				
PCB2						
PCB2	CIRCUIT NO.	PART NAME	DESCRIPTION	Q'TY	PART NO. (SN)	REMARKS
PCB2	U7041	REMO SENS	NJL34H380A	1	241365	
PCB2	Q7001	FL TUBE	16-BT-138GNK	1	212268	
PCB2	Q7001A	HOLDER	(FL)	1	27191222C	
PCB2	Q7003	IC	M66005-0001AHP	1	22242208R3	
PCB2	Q7004	TR	2SC2458-GR	1	2212115T	
PCB2	Q7004 or	TR	2SC1740S-R	(1)	2213284T	
PCB2	Q7004 or	TR	2SC1740S-S	(1)	2213285T	
PCB2	Q7005	TR	KRA102M	1	2215770T	
PCB2	Q7005 or	TR	DTA114ES	(1)	2213510T	
PCB2	Q7007	TR	KRC102M	1	2215960T	
PCB2	Q7007 or	TR	DTC114ES	(1)	2213290T	
PCB2	Q7033	TR	KTC3198-GR	1	2215985T	
PCB2	Q7033 or	TR	2SC1815-GR	(1)	2211255T	
PCB2	Q7401	IC	NJM4580D-D	1	22241112	
PCB2	Q7403	TR	KRC111M	1	2216320T	
PCB2	Q7403 or	TR	DTC114TS	(1)	221299T	
PCB2	Q7404	TR	KRC111M	1	2216320T	
PCB2	Q7404 or	TR	DTC114TS	(1)	221299T	
PCB2	D911	DIODE	1SS133	1	223163T	
PCB2	D912	DIODE	1SS133	1	223163T	
PCB2	D921	DIODE	1SS133	1	223163T	
PCB2	D922	DIODE	1SS133	1	223163T	
PCB2	D923	DIODE	1SS133	1	223163T	
PCB2	D924	DIODE	1SS133	1	223163T	
PCB2	D925	DIODE	1SS133	1	223163T	
PCB2	D930	DIODE	1SS133	1	223163T	
PCB2	D931	DIODE	1SS133	1	223163T	
PCB2	D933	DIODE	1SS133	1	223163T	
PCB2	D934	ZENER D	MTZJ5.1B	1	224470512T	

PCB2	D935	DIODE	ISS133	1	223163T	
PCB2	D7002	ZENER D	MTZJ8.2B	1	224470822T	
PCB2	D7033	ZENER D	MTZJ3.9B	1	224470392T	
PCB2	D7151	LED	SLI-343URC-TE7	1	225449T	
PCB2	D7401	ZENER D	MTZJ5.1B	1	224470512T	
PCB2	D7411	ZENER D	MTZJ6.8B	1	224470682T	
PCB2	D7412	ZENER D	MTZJ6.8B	1	224470682T	
PCB2	T902	P TRANS	NPT-1520JQ	1	2301812A	!, <MDC>
PCB2	T902	P TRANS	NPT-1520GQ	1	2301813A	!, <MPP>
PCB2	L7031	CHOKE COIL	NCH-1561 022K	1	233526K022T	
PCB2	L7201	CHOKE COIL	NCH-1561 022K	1	233526K022T	
PCB2	L7202	CHOKE COIL	NCH-1561 022K	1	233526K022T	
PCB2	L7203	CHOKE COIL	NCH-1561 022K	1	233526K022T	
PCB2	L7401	CHOKE COIL	NCH-1561 022K	1	233526K022T	
PCB2	L7402	CHOKE COIL	NCH-1561 022K	1	233526K022T	
PCB2	C901	IS C	LE103-C3.5	1	3800042S	!
PCB2	C901 or	IS C	ECQU2A103MLC	(1)	3800039S	!
PCB2	C902	TF C	ECQ-V50V-104J	1	374721044T	
PCB2	C911	TF C	ECQ-B50V-102J	1	374721024T	
PCB2	C921	CERA C	CK45F50V-223Z	1	335622230T	
PCB2	C922	VR C	CE04W25V-2200M(VR)	1	394652227S	<MDC>
PCB2	C922	VR C	CE04W16V-2200M(VR)	1	394642227S	<MPP>
PCB2	C930	UTSP C	CE04W50V-100M(UTSP)	1	397581017T	
PCB2	C933	UTSP C	CE04W50V-4.7M(UTSP)	1	397580477T	
PCB2	C7001	CERA C	CK45F50V-223Z	1	335622230T	
PCB2	C7002	MMT C	MMT50V-104J	1	375521044T	
PCB2	C7003	CERA C	CC45SL50V-101J	1	345021014T	
PCB2	C7004	CERA C	CC45SL50V-101J	1	345021014T	
PCB2	C7005	CERA C	CC45SL50V-101J	1	345021014T	
PCB2	C7007	CERA C	CC45SL50V-101J	1	345021014T	
PCB2	C7008	UTSP C	CE04W10V-100M(UTSP)	1	397531017T	
PCB2	C7009	MMT C	MMT50V-104J	1	375521044T	
PCB2	C7010	CERA C	CK45F50V-223Z	1	335622230T	

PCB2	C7011	CERA C	CK45F50V-223Z	1	335622230T
PCB2	C7012	CERA C	CK45F50V-223Z	1	335622230T
PCB2	C7013	UTSP C	CE04W50V-47M(UTSP)	1	397584707T
PCB2	C7014	CERA C	CK45F50V-223Z	1	335622230T
PCB2	C7015	ELECT C	CE04W16V-47M(S)	1	353744709T
PCB2	C7016	CERA C	CK45F50V-223Z	1	335622230T
PCB2	C7017	CERA C	CK45F50V-223Z	1	335622230T
PCB2	C7021	CERA C	CK45F50V-103Z	1	335621030T
PCB2	C7022	CERA C	CK45F50V-103Z	1	335621030T
PCB2	C7031	CERA C	CK45F50V-223Z	1	335622230T
PCB2	C7032	CERA C	CK45F50V-223Z	1	335622230T
PCB2	C7033	UTSP C	CE04W50V-10M(UTSP)	1	397581007T
PCB2	C7041	ELECT C	CE04W6.3V-100M(S)	1	353721019T
PCB2	C7043	CERA C	CK45B50V-102K	1	335321025T
PCB2	C7201	TF C	ECQ-B50V-102J	1	374721024T
PCB2	C7202	TF C	ECQ-B50V-223J	1	374722234T
PCB2	C7203	TF C	ECQ-B50V-102J	1	374721024T
PCB2	C7204	TF C	ECQ-B50V-102J	1	374721024T
PCB2	C7301	TF C	ECQ-B50V-471J	1	374724714T
PCB2	C7302	TF C	ECQ-B50V-471J	1	374724714T
PCB2	C7303	MMT C	MMT50V-104J	1	375521044T
PCB2	C7304	MMT C	MMT50V-104J	1	375521044T
PCB2	C7305	MMT C	MMT50V-104J	1	375521044T
PCB2	C7401	UTSP C	CE04W50V-10M(UTSP)	1	397581007T
PCB2	C7402	CERA C	CC45SL50V-101J	1	345021014T
PCB2	C7403	UTSP C	CE04W25V-47M(UTSP)	1	397554707T
PCB2	C7404	CERA C	CC45SL50V-330J	1	345023304T
PCB2	C7405	ELECT C	CE04W16V-10M(S)	1	353741009T
PCB2	C7411	UTSP C	CE04W25V-47M(UTSP)	1	397554707T
PCB2	C7412	UTSP C	CE04W25V-47M(UTSP)	1	397554707T
PCB2	C7421	CERA C	CK45B50V-102K	1	335321025T
PCB2	C9101	MMT C	MMT50V-104J	1	375521044T
PCB2	R921	METAL O R	RS1/2WBJ-47	1	443524704T

PCB2	R934	CARBON R	R16J-100K	1	417341044T
PCB2	R7001	CARBON R	R16J-100K	1	417341044T
PCB2	R7002	CARBON R	R16J-3.3K	1	417343324T
PCB2	R7003	CARBON R	R16J-3.3K	1	417343324T
PCB2	R7004	CARBON R	R16J-220	1	417342214T
PCB2	R7005	CARBON R	R16J-220	1	417342214T
PCB2	R7006	CARBON R	R16J-18K	1	417341834T
PCB2	R7007	CARBON R	R16J-220	1	417342214T
PCB2	R7008	CARBON R	R16J-220	1	417342214T
PCB2	R7021	CARBON R	R16J-10K	1	417341034T
PCB2	R7022	CARBON R	R16J-10K	1	417341034T
PCB2	R7023	CARBON R	R16J-10K	1	417341034T
PCB2	R7024	CARBON R	R16J-10K	1	417341034T
PCB2	R7033	CARBON R	R16J-82	1	417348204T
PCB2	R7041	CARBON R	R16J-100	1	417341014T
PCB2	R7042	CARBON R	R16J-1K	1	417341024T
PCB2	R7101	CARBON R	R16J-330	1	417343314T
PCB2	R7102	CARBON R	R16J-470	1	417344714T
PCB2	R7103	CARBON R	R16J-560	1	417345614T
PCB2	R7104	CARBON R	R16J-820	1	417348214T
PCB2	R7105	CARBON R	R16J-1.2K	1	417341224T
PCB2	R7107	CARBON R	R16J-330	1	417343314T
PCB2	R7108	CARBON R	R16J-470	1	417344714T
PCB2	R7109	CARBON R	R16J-560	1	417345614T
PCB2	R7110	CARBON R	R16J-820	1	417348214T
PCB2	R7111	CARBON R	R16J-1.2K	1	417341224T
PCB2	R7112	CARBON R	R16J-2.2K	1	417342224T
PCB2	R7113	CARBON R	R16J-3.9K	1	417343924T
PCB2	R7114	CARBON R	R16J-12K	1	417341234T
PCB2	R7115	CARBON R	R16J-330	1	417343314T
PCB2	R7116	CARBON R	R16J-470	1	417344714T
PCB2	R7117	CARBON R	R16J-560	1	417345614T
PCB2	R7118	CARBON R	R16J-820	1	417348214T

PCB2	R7119	CARBON R	R16J-1.2K	1	417341224T	
PCB2	R7120	CARBON R	R16J-2.2K	1	417342224T	
PCB2	R7121	CARBON R	R16J-3.9K	1	417343924T	
PCB2	R7122	CARBON R	R16J-12K	1	417341234T	
PCB2	R7123	CARBON R	R16J-330	1	417343314T	
PCB2	R7124	CARBON R	R16J-470	1	417344714T	
PCB2	R7125	CARBON R	R16J-560	1	417345614T	
PCB2	R7126	CARBON R	R16J-820	1	417348214T	
PCB2	R7127	CARBON R	R16J-1.2K	1	417341224T	
PCB2	R7128	CARBON R	R16J-2.2K	1	417342224T	
PCB2	R7129	CARBON R	R16J-3.9K	1	417343924T	
PCB2	R7130	CARBON R	R16J-12K	1	417341234T	
PCB2	R7151	CARBON R	R16J-2.2K	1	417342224T	
PCB2	R7301	CARBON R	R16J-330	1	417343314T	
PCB2	R7302	CARBON R	R16J-330	1	417343314T	
PCB2	R7401	CARBON R	R16J-100	1	417341014T	
PCB2	R7402	CARBON R	R16J-220K	1	417342244T	
PCB2	R7403	CARBON R	R16J-4.7K	1	417344724T	
PCB2	R7404	CARBON R	R16J-220	1	417342214T	
PCB2	R7405	CARBON R	R16J-47K	1	417344734T	
PCB2	R7406	CARBON R	R16J-330	1	417343314T	
PCB2	R7407	CARBON R	R16J-1K	1	417341024T	
PCB2	R7408	CARBON R	R16J-33K	1	417343334T	
PCB2	R7409	CARBON R	R16J-220	1	417342214T	
PCB2	R7410	CARBON R	R16J-220	1	417342214T	
PCB2	R7411	CARBON R	R16J-470	1	417344714T	
PCB2	R7412	CARBON R	R16J-470	1	417344714T	
PCB2	R7413	CARBON R	R16J-220K	1	417342244T	
PCB2	R7414	CARBON R	R16J-100K	1	417341044T	
PCB2	R9101	METAL R	RNU1/2WCJ-0.1	1	453531094T	!, <MDC>
PCB2	R9101	METAL R	RNU1/2WCJ-0.22	1	453532294T	!, <MPP>
PCB2	R9102	METAL R	RNU1/2WCJ-8.2	1	453530824T	
PCB2	RL901	RELAY	NRL-1P5A-DC9-179	1	25065669	!

PCB2	S7001	R ENCODE	EC12E2425WITH WASHER	1	25065655W	
PCB2	S7101	PUSH SW	NPS-111-S681	1	25035718T	
PCB2	S7104	PUSH SW	NPS-111-S681	1	25035718T	
PCB2	S7106	PUSH SW	NPS-111-S681	1	25035718T	
PCB2	S7107	PUSH SW	NPS-111-S681	1	25035718T	
PCB2	S7109	PUSH SW	NPS-111-S681	1	25035718T	
PCB2	S7115	PUSH SW	NPS-111-S681	1	25035718T	
PCB2	S7117	PUSH SW	NPS-111-S681	1	25035718T	
PCB2	S7119	PUSH SW	NPS-111-S681	1	25035718T	
PCB2	S7123	PUSH SW	NPS-111-S681	1	25035718T	
PCB2	S7125	PUSH SW	NPS-111-S681	1	25035718T	
PCB2	S7127	PUSH SW	NPS-111-S681	1	25035718T	
PCB2	S7129	PUSH SW	NPS-111-S681	1	25035718T	
PCB2	S7132	PUSH SW	NPS-111-S681	1	25035718T	
PCB2	S7134	PUSH SW	NPS-111-S681	1	25035718T	
PCB2	S7136	PUSH SW	NPS-111-S681	1	25035718T	
PCB2	S7138	PUSH SW	NPS-111-S681	1	25035718T	
PCB2	S7140	PUSH SW	NPS-111-S681	1	25035718T	
PCB2	S7142	PUSH SW	NPS-111-S681	1	25035718T	
PCB2	S7144	PUSH SW	NPS-111-S681	1	25035718T	
PCB2	S7146	PUSH SW	NPS-111-S681	1	25035718T	
PCB2	S7148	PUSH SW	NPS-111-S681	1	25035718T	
PCB2	S7149	PUSH SW	NPS-111-S681	1	25035718T	
PCB2	S7151	PUSH SW	NPS-111-S681	1	25035718T	
PCB2	S7153	PUSH SW	NPS-111-S681	1	25035718T	
PCB2	S7155	PUSH SW	NPS-111-S681	1	25035718T	
PCB2	S7157	PUSH SW	NPS-111-S681	1	25035718T	
PCB2	S7159	PUSH SW	NPS-111-S681	1	25035718T	
PCB2	S7161	PUSH SW	NPS-111-S681	1	25035718T	
PCB2	S7164	PUSH SW	NPS-111-S681	1	25035718T	
PCB2	S7166	PUSH SW	NPS-111-S681	1	25035718T	
PCB2	P701B	SOCKET	NSCT-33P2163	1	25052266	
PCB2	P901A	PLUG	NPLG-2P631	1	25055675	!

PCB2	P901A or	PLUG	1-1123724-2	(1)	25056402	!
PCB2	P911	PLUG	NPLG-2P631	1	25055675	!
PCB2	P911 or	PLUG	1-1123724-2	(1)	25056402	!
PCB2	P7201	ST JACK	MSJ-064-05A SR	1	25045783	
PCB2	P7201 or	ST JACK	YKB21-5005	(1)	25045724	
PCB2	P7301	PIN JACK	NPJ-7PDB477	1	25045680	
PCB2	P7401	ST JACK	MSJ-035-05C B AG SR type	1	25045879	
PCB2	E7201	TRM-423(SCREW)	NEJITANSI ST3	1	25060495	
PCB2	E7301	RETAINER	(S)	1	27142074	
PCB2	E901	TRM-423(SCREW)	NEJITANSI ST3	1	25060495	
PCB2	E902	TRM-423(SCREW)	NEJITANSI ST3	1	25060495	
PCB2	F901C	FUSE HOL	NSCT-1P2031	1	25052133T	!
PCB2	F901D	FUSE HOL	NSCT-1P2031	1	25052133T	!
PCB2	JL6605	JUMPER LEAD	JL5 350 H	1	---	NSP
PCB2	JL6605A	WIRE HOL	NSCT-5P896	1	25051109	
PCB2	JL7101	JUMPER LEAD	JL9 200 H	1	---	NSP
PCB2	JL7101A	WIRE HOL	NSCT-9P900	1	25051113	
PCB2	JL7101B	WIRE HOL	NSCT-9P900	1	25051113	
PCB2	JL901	JUMPER LEAD	JL5 300 B	1	---	NSP
PCB2	JL901A	WIRE HOL	NSCT-5P876	1	25051089	
PCB2	JL9101	JUMPER LEAD	JL7 350 H	1	---	NSP
PCB2	JL9101A	WIRE HOL	NSCT-7P898	1	25051111	
PCB3	U32	MICROPROCESSOR PC BOARD (NADG-9462-1H /1J)				
PCB3	U33	XM/ DOCK TERMINAL PC BOARD (NARF-9463-1H/ 1J)				
PCB3						
PCB3	CIRCUIT NO.	PART NAME	DESCRIPTION	Q'TY	PART NO. (SN)	REMARKS
PCB3	U301	PHT CP	JSR1165-001recieving	1	24120143	
PCB3	U301 or	PHT CP	GP1FAV51RK0F	(1)	24120129	
PCB3	U302	PHT CP	JSR1165-001recieving	1	24120143	
PCB3	U302 or	PHT CP	GP1FAV51RK0F	(1)	24120129	
PCB3	Q301	IC	CS42528-CQZR-D	1	22242275R2	
PCB3	Q302	IC	TC74VHC157FT	1	22274157ER2TO	

PCB3	Q303	IC	TC7WU04FU(TE12L_F)	1	22240935R2
PCB3	Q304	IC	74HCU04F	1	222740046R2
PCB3	Q305	IC	NJM2860F3-33	1	22242087R2
PCB3	Q306	IC	NJM4580M-D	1	22241448R2
PCB3	Q307	TR	2SC2235-Y(TPE6_F)	1	2211654T
PCB3	Q401	IC	NJM4580M-D	1	22241448R2
PCB3	Q402	IC	NJM4580M-D	1	22241448R2
PCB3	Q403	IC	NJM4580M-D	1	22241448R2
PCB3	Q404	IC	NJM4580M-D	1	22241448R2
PCB3	Q701	IC (MAIN MICROPROCESSOR)	MPD70F3746 (0294)	1	222W0079R302940
PCB3	Q702	IC	S-812C33AUA-C2N	1	22242222R2
PCB3	Q703	IC	S-812C56AUA-C3K	1	22242207R2
PCB3	Q704	IC	TC74VHCT541AFT	1	22274541GR2TO
PCB3	Q705	IC	R1EX25064ASA00A	1	22242581R2
PCB3	Q706	TR	KRC104S	1	2216210R2
PCB3	Q706 or	TR	RN1404	(1)	2214490R2
PCB3	Q707	TR	KRA107S	1	2216350R2
PCB3	Q707 or	TR	RN2407(TE85L_F)	(1)	2216360R2
PCB3	Q707 or	TR	DTA114YKA	(1)	2216480R2
PCB3	Q708	TR	KRC107S	1	2216340R2
PCB3	Q708 or	TR	RN1407	(1)	2216260R2
PCB3	Q708 or	TR	DTC114YKA	(1)	2216470R2
PCB3	Q709	TR	KRC107S	1	2216340R2
PCB3	Q709 or	TR	RN1407	(1)	2216260R2
PCB3	Q709 or	TR	DTC114YKA	(1)	2216470R2
PCB3	Q710	TR	KRA107S	1	2216350R2
PCB3	Q710 or	TR	RN2407(TE85L_F)	(1)	2216360R2
PCB3	Q710 or	TR	DTA114YKA	(1)	2216480R2
PCB3	Q711	TR	KRC107S	1	2216340R2
PCB3	Q711 or	TR	RN1407	(1)	2216260R2
PCB3	Q711 or	TR	DTC114YKA	(1)	2216470R2
PCB3	Q712	TR	KRC104S	1	2216210R2
PCB3	Q712 or	TR	RN1404	(1)	2214490R2

PCB3	Q713	TR	KRA102S	1	2216220R2	
PCB3	Q713 or	TR	RN2402	(1)	2214530R2	
PCB3	D301	C-DIODE	KDS4148U	1	223283R2	
PCB3	D301 or	C-DIODE	1SS352	(1)	223234R2	
PCB3	D301 or	C-DIODE	MA2J111	(1)	223279R2	
PCB3	D302	C-DIODE	KDS4148U	1	223283R2	
PCB3	D302 or	C-DIODE	1SS352	(1)	223234R2	
PCB3	D302 or	C-DIODE	MA2J111	(1)	223279R2	
PCB3	D303	ZENER D	MAZ8100-M	1	224751002R2	
PCB3	D303 or	ZENER D	UDZS10B	(1)	224551000R2	
PCB3	D601	C-DIODE	KDS4148U	1	223283R2	
PCB3	D601 or	C-DIODE	1SS352	(1)	223234R2	
PCB3	D601 or	C-DIODE	MA2J111	(1)	223279R2	
PCB3	D602	C-DIODE	KDS4148U	1	223283R2	
PCB3	D602 or	C-DIODE	1SS352	(1)	223234R2	
PCB3	D602 or	C-DIODE	MA2J111	(1)	223279R2	
PCB3	D603	C-DIODE	KDS4148U	1	223283R2	
PCB3	D603 or	C-DIODE	1SS352	(1)	223234R2	
PCB3	D603 or	C-DIODE	MA2J111	(1)	223279R2	
PCB3	D604	C-DIODE	KDS4148U	1	223283R2	
PCB3	D604 or	C-DIODE	1SS352	(1)	223234R2	
PCB3	D604 or	C-DIODE	MA2J111	(1)	223279R2	
PCB3	D605	C-DIODE	KDS4148U	1	223283R2	
PCB3	D605 or	C-DIODE	1SS352	(1)	223234R2	
PCB3	D605 or	C-DIODE	MA2J111	(1)	223279R2	
PCB3	D2082	C-DIODE	KDS4148U	1	223283R2	<MDC>
PCB3	D2082 or	C-DIODE	1SS352	(1)	223234R2	<MDC>
PCB3	D2082 or	C-DIODE	MA2J111	(1)	223279R2	<MDC>
PCB3	D2083	C-DIODE	KDS4148U	1	223283R2	<MDC>
PCB3	D2083 or	C-DIODE	1SS352	(1)	223234R2	<MDC>
PCB3	D2083 or	C-DIODE	MA2J111	(1)	223279R2	<MDC>
PCB3	X301	CRYSTAL	HC-49US24.576MHz	1	3010423T	
PCB3	X701	CERA LOCK	CSTCR5M00G53-B0	1	3010356R2	

PCB3	L301	CHOKE COIL	BLM21PG221SN1	1	230949R2
PCB3	L302	CHOKE COIL	BLM21PG221SN1	1	230949R2
PCB3	L303	CHOKE COIL	BLM21PG221SN1	1	230949R2
PCB3	L304	CHOKE COIL	LBC2518T4R7M	1	231364M047R2
PCB3	L305	CHOKE COIL	BLM21PG221SN1	1	230949R2
PCB3	L306	CHOKE COIL	LBC2518T470M	1	231364M470R2
PCB3	L307	CHOKE COIL	LBC2518T470M	1	231364M470R2
PCB3	L308	CHOKE COIL	LBC2518T470M	1	231364M470R2
PCB3	L309	CHOKE COIL	LBC2518T2R2M	1	231364M022R2
PCB3	L310	CHOKE COIL	LBC2518T2R2M	1	231364M022R2
PCB3	L313	EMIFIL	BK1608LM182-T	1	230958R1
PCB3	L316	EMIFIL	BK1608LM182-T	1	230958R1
PCB3	L321	EMIFIL	BK1608LM182-T	1	230958R1
PCB3	L322	EMIFIL	BK1608LM182-T	1	230958R1
PCB3	L611	CHOKE COIL	LBC2518T470M	1	231364M470R2
PCB3	C301	UTSP C	CE04W10V-470M(UTSP)	1	397534717T
PCB3	C302	UTSP C	CE04W10V-470M(UTSP)	1	397534717T
PCB3	C303	UTSP C	CE04W25V-100M(UTSP)	1	397551017T
PCB3	C304	UTSP C	CE04W10V-470M(UTSP)	1	397534717T
PCB3	C305	UTSI C	CE04W25V-47M(UTSJ)	1	398054707T
PCB3	C306	UTSP C	CE04W10V-100M(UTSP)	1	397531017T
PCB3	C307	C-CERA C	CK725F1E-104Z1	1	332161040R1
PCB3	C308	C-CERA C	CK725F1E-104Z1	1	332161040R1
PCB3	C309	C-CERA C	CK725F1E-104Z1	1	332161040R1
PCB3	C310	C-CERA C	CC725CH1H-102J1	1	342101024R1
PCB3	C311	C-CERA C	CK725B1H-223K1	1	332102235R1
PCB3	C312	C-CERA C	CK725F1E-104Z1	1	332161040R1
PCB3	C313	C-CERA C	CK725F1E-104Z1	1	332161040R1
PCB3	C314	C-CERA C	CK725F1E-104Z1	1	332161040R1
PCB3	C315	C-CERA C	CK725F1E-104Z1	1	332161040R1
PCB3	C316	C-CERA C	CC725CH1H-221J1	1	342102214R1
PCB3	C317	C-CERA C	CK725F1E-104Z1	1	332161040R1
PCB3	C318	C-CERA C	CC725CH1H-060D1	1	342100602R1

PCB3	C319	C-CERA C	CC725CH1H-060D1	1	342100602R1
PCB3	C320	C-CERA C	CK725F1E-104Z1	1	332161040R1
PCB3	C321	UTSP C	CE04W10V-220M(UTSP)	1	397532217T
PCB3	C322	C-CERA C	CK725F1E-104Z1	1	332161040R1
PCB3	C323	C-CERA C	CK725F1E-104Z1	1	332161040R1
PCB3	C324	UTSP C	CE04W10V-220M(UTSP)	1	397532217T
PCB3	C325	C-CERA C	CC725CH1H-080D1	1	342100802R1
PCB3	C326	C-CERA C	CC725CH1H-080D1	1	342100802R1
PCB3	C328	C-CERA C	CK725F1E-104Z1	1	332161040R1
PCB3	C329	C-CERA C	CK725F1E-104Z1	1	332161040R1
PCB3	C330	C-CERA C	CK725F1E-104Z1	1	332161040R1
PCB3	C332	C-CERA C	CC725CH1H-330J1	1	342103304R1
PCB3	C333	C-CERA C	CC725CH1H-330J1	1	342103304R1
PCB3	C334	C-CERA C	CC725CH1H-330J1	1	342103304R1
PCB3	C335	C-CERA C	CC725CH1H-330J1	1	342103304R1
PCB3	C336	C-CERA C	CK725B1H-103K1	1	332101035R1
PCB3	C337	C-CERA C	CK725B1H-102K1	1	332101025R1
PCB3	C338	C-CERA C	CK725F1E-104Z1	1	332161040R1
PCB3	C339	UTSP C	CE04W50V-47M(UTSP)	1	397584707T
PCB3	C340	C-CERA C	CK725F1E-104Z1	1	332161040R1
PCB3	C351	C-CERA C	CC725CH1H-101J1	1	342101014R1
PCB3	C352	C-CERA C	CC725CH1H-101J1	1	342101014R1
PCB3	C353	C-CERA C	CK725B1C-104K1	1	332121045R1
PCB3	C354	C-CERA C	CK725B1C-104K1	1	332121045R1
PCB3	C355	C-CERA C	CK725F1E-104Z1	1	332161040R1
PCB3	C363	C-CERA C	CC725CH1H-101J1	1	342101014R1
PCB3	C364	C-CERA C	CC725CH1H-101J1	1	342101014R1
PCB3	C365	UTSP C	CE04W25V-47M(UTSP)	1	397554707T
PCB3	C366	UTSP C	CE04W25V-47M(UTSP)	1	397554707T
PCB3	C367	UTSP C	CE04W25V-47M(UTSP)	1	397554707T
PCB3	C368	UTSP C	CE04W25V-47M(UTSP)	1	397554707T
PCB3	C369	C-FILM C	ECHU50V-222J	1	373022224R2
PCB3	C370	C-FILM C	ECHU50V-222J	1	373022224R2

PCB3	C375	C-CERA C	CK725F1A-105Z1	1	332181050R1
PCB3	C376	C-CERA C	CK725F1A-105Z1	1	332181050R1
PCB3	C377	C-CERA C	CK725F1E-104Z1	1	332161040R1
PCB3	C378	C-CERA C	CK725F1E-104Z1	1	332161040R1
PCB3	C379	C-CERA C	CK725F1E-104Z1	1	332161040R1
PCB3	C401	TF C	ECQ-B50V-222J	1	374722224T
PCB3	C402	TF C	ECQ-B50V-222J	1	374722224T
PCB3	C403	TF C	ECQ-B50V-222J	1	374722224T
PCB3	C404	TF C	ECQ-V50V-333J	1	374723334T
PCB3	C405	TF C	ECQ-B50V-222J	1	374722224T
PCB3	C406	TF C	ECQ-B50V-222J	1	374722224T
PCB3	C407	TF C	ECQ-B50V-222J	1	374722224T
PCB3	C408	TF C	ECQ-B50V-222J	1	374722224T
PCB3	C409	UTSP C	CE04W25V-47M(UTSP)	1	397554707T
PCB3	C410	UTSP C	CE04W25V-47M(UTSP)	1	397554707T
PCB3	C411	TF C	ECQ-B50V-331K	1	374723315T
PCB3	C412	TF C	ECQ-B50V-331K	1	374723315T
PCB3	C413	TF C	ECQ-B50V-331K	1	374723315T
PCB3	C414	TF C	ECQ-V50V-333J	1	374723334T
PCB3	C415	C-CERA C	CC725CH1H-331J1	1	342103314R1
PCB3	C416	C-CERA C	CC725CH1H-331J1	1	342103314R1
PCB3	C417	C-CERA C	CC725CH1H-331J1	1	342103314R1
PCB3	C418	C-CERA C	CC725CH1H-331J1	1	342103314R1
PCB3	C421	TF C	ECQ-B50V-331K	1	374723315T
PCB3	C422	TF C	ECQ-B50V-331K	1	374723315T
PCB3	C423	TF C	ECQ-B50V-331K	1	374723315T
PCB3	C424	TF C	ECQ-V50V-333J	1	374723334T
PCB3	C425	C-CERA C	CC725CH1H-331J1	1	342103314R1
PCB3	C426	C-CERA C	CC725CH1H-331J1	1	342103314R1
PCB3	C427	C-CERA C	CC725CH1H-331J1	1	342103314R1
PCB3	C428	C-CERA C	CC725CH1H-331J1	1	342103314R1
PCB3	C601	C-CERA C	CK725F1E-104Z1	1	332161040R1
PCB3	C602	C-CERA C	CK725F1E-104Z1	1	332161040R1

PCB3	C603	UTSP C	CE04W50V-4.7M(UTSP)	1	397580477T	
PCB3	C605	C-CERA C	CK725F1E-104Z1	1	332161040R1	
PCB3	C606	C-CERA C	CK725F1E-104Z1	1	332161040R1	
PCB3	C607	UTSP C	CE04W50V-4.7M(UTSP)	1	397580477T	
PCB3	C608	C-CERA C	CK725F1E-104Z1	1	332161040R1	
PCB3	C609	C-CERA C	CK725F1E-104Z1	1	332161040R1	
PCB3	C610	C-CERA C	CK725B1H-102K1	1	332101025R1	
PCB3	C611	C-CERA C	CK725B1H-102K1	1	332101025R1	
PCB3	C615	UTSP C	CE04W25V-220M(UTSP)	1	397552217T	
PCB3	C616	UTSP C	CE04W25V-220M(UTSP)	1	397552217T	
PCB3	C618	C-CERA C	CC725CH1H-101J1	1	342101014R1	
PCB3	C619	C-CERA C	CC725CH1H-101J1	1	342101014R1	
PCB3	C621	C-CERA C	CK725B1H-102K1	1	332101025R1	
PCB3	C622	C-CERA C	CK725F1E-104Z1	1	332161040R1	
PCB3	C623	C-CERA C	CK725B1H-102K1	1	332101025R1	
PCB3	C624	C-CERA C	CK725B1H-102K1	1	332101025R1	
PCB3	C625	C-CERA C	CK725B1H-102K1	1	332101025R1	
PCB3	C626	C-CERA C	CK725B1H-102K1	1	332101025R1	
PCB3	C627	C-CERA C	CK725B1H-102K1	1	332101025R1	
PCB3	C628	C-CERA C	CK725F1E-104Z1	1	332161040R1	
PCB3	C629	C-CERA C	CK725F1E-104Z1	1	332161040R1	
PCB3	C631	C-CERA C	CK725F1A-105Z1	1	332181050R1	
PCB3	C634	UTSP C	CE04W25V-220M(UTSP)	1	397552217T	
PCB3	C635	UTSP C	CE04W25V-100M(UTSP)	1	397551017T	
PCB3	C636	C-CERA C	CK725F1E-104Z1	1	332161040R1	
PCB3	C637	UTSP C	CE04W25V-100M(UTSP)	1	397551017T	
PCB3	C639	C-CERA C	CK725F1E-104Z1	1	332161040R1	
PCB3	C641	C-CERA C	CK725F1E-104Z1	1	332161040R1	
PCB3	C642	C-CERA C	CK725F1E-104Z1	1	332161040R1	
PCB3	C643	VR C	CE04W6.3V-470M(VR)	1	394624717T	
PCB3	C644	UTSP C	CE04W50V-0.47M(UTSP)	1	397584797T	
PCB3	C647	C-CERA C	CK725F1E-104Z1	1	332161040R1	
PCB3	R106	C-CARBON R	RN72K1J-000JE	1	435030004R1	<MDC>

PCB3	R107	C-CARBON R	RN72K1J-000JE	1	435030004R1	<MDC>
PCB3	R301	C-CARBON R	RN72K1J-331JE	1	435033314R1	
PCB3	R302	C-CARBON R	RN72K1J-331JE	1	435033314R1	
PCB3	R303	C-CARBON R	RN72K1J-331JE	1	435033314R1	
PCB3	R304	C-CARBON R	RN72K1J-331JE	1	435033314R1	
PCB3	R305	C-CARBON R	RN72K1J-470JE	1	435034704R1	
PCB3	R306	C-CARBON R	RN72K1J-331JE	1	435033314R1	
PCB3	R307	C-CARBON R	RN72K1J-331JE	1	435033314R1	
PCB3	R308	C-CARBON R	RN72K1J-470JE	1	435034704R1	
PCB3	R309	C-CARBON R	RN72K1J-331JE	1	435033314R1	
PCB3	R310	C-CARBON R	RN72K1J-152JE	1	435031524R1	
PCB3	R312	C-CARBON R	RN72K1J-470JE	1	435034704R1	
PCB3	R313	C-CARBON R	RN72K1J-151JE	1	435031514R1	
PCB3	R314	C-CARBON R	RN72K1J-221JE	1	435032214R1	
PCB3	R315	C-CARBON R	RN72K1J-470JE	1	435034704R1	
PCB3	R316	C-CARBON R	RN72K1J-470JE	1	435034704R1	
PCB3	R317	C-CARBON R	RN72K1J-331JE	1	435033314R1	
PCB3	R318	C-CARBON R	RN72K1J-331JE	1	435033314R1	
PCB3	R319	C-CARBON R	RN72K1J-331JE	1	435033314R1	
PCB3	R321	C-CARBON R	RN72K1J-331JE	1	435033314R1	
PCB3	R322	C-CARBON R	RN72K1J-470JE	1	435034704R1	
PCB3	R323	C-CARBON R	RN72K1J-331JE	1	435033314R1	
PCB3	R324	C-CARBON R	RN72K1J-221JE	1	435032214R1	
PCB3	R325	C-CARBON R	RN72K1J-151JE	1	435031514R1	
PCB3	R326	C-CARBON R	RN72K1J-105JE	1	435031054R1	
PCB3	R328	C-CARBON R	RN72K1J-221JE	1	435032214R1	
PCB3	R329	C-CARBON R	RN72K1J-221JE	1	435032214R1	
PCB3	R331	C-CARBON R	RN72K1J-331JE	1	435033314R1	
PCB3	R332	C-CARBON R	RN72K1J-331JE	1	435033314R1	
PCB3	R333	C-CARBON R	RN72K1J-331JE	1	435033314R1	
PCB3	R334	C-CARBON R	RN72K1J-331JE	1	435033314R1	
PCB3	R335	C-CARBON R	RN72K1J-331JE	1	435033314R1	
PCB3	R337	C-CARBON R	RN72K1J-103JE	1	435031034R1	

PCB3	R338	C-CARBON R	RN72K1J-103JE	1	435031034R1
PCB3	R339	C-CARBON R	RN72K1J-823JE	1	435038234R1
PCB3	R340	C-CARBON R	RN72K1J-823JE	1	435038234R1
PCB3	R341	C-CARBON R	RN72K1J-470JE	1	435034704R1
PCB3	R342	C-CARBON R	RN72K1J-470JE	1	435034704R1
PCB3	R345	C-CARBON R	RN72K1J-000JE	1	435030004R1
PCB3	R348	C-CARBON R	RN72K1J-333JE	1	435033334R1
PCB3	R349	METAL O R	RS1WBJ-22	1	443622204T
PCB3	R351	C-CARBON R	RN72K1J-750JE	1	435037504R1
PCB3	R352	C-CARBON R	RN72K1J-750JE	1	435037504R1
PCB3	R353	C-CARBON R	RN72K1J-100JE	1	435031004R1
PCB3	R354	C-CARBON R	RN72K1J-100JE	1	435031004R1
PCB3	R355	C-CARBON R	RN72K1J-224JE	1	435032244R1
PCB3	R356	C-CARBON R	RN72K1J-224JE	1	435032244R1
PCB3	R361	C-CARBON R	RN72K1J-103JE	1	435031034R1
PCB3	R362	C-CARBON R	RN72K1J-103JE	1	435031034R1
PCB3	R363	C-CARBON R	RN72K1J-103JE	1	435031034R1
PCB3	R364	C-CARBON R	RN72K1J-103JE	1	435031034R1
PCB3	R365	C-CARBON R	RN72K1J-560JE	1	435035604R1
PCB3	R366	C-CARBON R	RN72K1J-560JE	1	435035604R1
PCB3	R367	C-CARBON R	RN72K1J-560JE	1	435035604R1
PCB3	R368	C-CARBON R	RN72K1J-560JE	1	435035604R1
PCB3	R369	C-CARBON R	RN72K1J-392JE	1	435033924R1
PCB3	R370	C-CARBON R	RN72K1J-392JE	1	435033924R1
PCB3	R371	C-CARBON R	RN72K1J-103JE	1	435031034R1
PCB3	R401	C-CARBON R	RN72K1J-332JE	1	435033324R1
PCB3	R402	C-CARBON R	RN72K1J-332JE	1	435033324R1
PCB3	R403	C-CARBON R	RN72K1J-332JE	1	435033324R1
PCB3	R404	C-CARBON R	RN72K1J-332JE	1	435033324R1
PCB3	R405	C-CARBON R	RN72K1J-332JE	1	435033324R1
PCB3	R406	C-CARBON R	RN72K1J-332JE	1	435033324R1
PCB3	R407	C-CARBON R	RN72K1J-332JE	1	435033324R1
PCB3	R408	C-CARBON R	RN72K1J-332JE	1	435033324R1

PCB3	R411	C-CARBON R	RN72K1J-332JE	1	435033324R1
PCB3	R412	C-CARBON R	RN72K1J-332JE	1	435033324R1
PCB3	R413	C-CARBON R	RN72K1J-332JE	1	435033324R1
PCB3	R414	C-CARBON R	RN72K1J-332JE	1	435033324R1
PCB3	R415	C-CARBON R	RN72K1J-332JE	1	435033324R1
PCB3	R416	C-CARBON R	RN72K1J-332JE	1	435033324R1
PCB3	R417	C-CARBON R	RN72K1J-332JE	1	435033324R1
PCB3	R418	C-CARBON R	RN72K1J-332JE	1	435033324R1
PCB3	R421	C-CARBON R	RN72K1J-471JE	1	435034714R1
PCB3	R422	C-CARBON R	RN72K1J-471JE	1	435034714R1
PCB3	R423	C-CARBON R	RN72K1J-471JE	1	435034714R1
PCB3	R424	C-CARBON R	RN72K1J-471JE	1	435034714R1
PCB3	R425	C-CARBON R	RN72K1J-471JE	1	435034714R1
PCB3	R426	C-CARBON R	RN72K1J-471JE	1	435034714R1
PCB3	R427	C-CARBON R	RN72K1J-471JE	1	435034714R1
PCB3	R428	C-CARBON R	RN72K1J-471JE	1	435034714R1
PCB3	R431	C-CARBON R	RN72K1J-471JE	1	435034714R1
PCB3	R432	C-CARBON R	RN72K1J-471JE	1	435034714R1
PCB3	R433	C-CARBON R	RN72K1J-471JE	1	435034714R1
PCB3	R434	C-CARBON R	RN72K1J-471JE	1	435034714R1
PCB3	R435	C-CARBON R	RN72K1J-471JE	1	435034714R1
PCB3	R436	C-CARBON R	RN72K1J-471JE	1	435034714R1
PCB3	R437	C-CARBON R	RN72K1J-471JE	1	435034714R1
PCB3	R438	C-CARBON R	RN72K1J-471JE	1	435034714R1
PCB3	R441	C-CARBON R	RN72K1J-472JE	1	435034724R1
PCB3	R442	C-CARBON R	RN72K1J-472JE	1	435034724R1
PCB3	R443	C-CARBON R	RN72K1J-472JE	1	435034724R1
PCB3	R444	C-CARBON R	RN72K1J-472JE	1	435034724R1
PCB3	R445	C-CARBON R	RN72K1J-472JE	1	435034724R1
PCB3	R446	C-CARBON R	RN72K1J-472JE	1	435034724R1
PCB3	R447	C-CARBON R	RN72K1J-472JE	1	435034724R1
PCB3	R448	C-CARBON R	RN72K1J-472JE	1	435034724R1
PCB3	R451	C-CARBON R	RN72K1J-472JE	1	435034724R1

PCB3	R452	C-CARBON R	RN72K1J-472JE	1	435034724R1
PCB3	R453	C-CARBON R	RN72K1J-472JE	1	435034724R1
PCB3	R454	C-CARBON R	RN72K1J-472JE	1	435034724R1
PCB3	R455	C-CARBON R	RN72K1J-472JE	1	435034724R1
PCB3	R456	C-CARBON R	RN72K1J-472JE	1	435034724R1
PCB3	R457	C-CARBON R	RN72K1J-472JE	1	435034724R1
PCB3	R458	C-CARBON R	RN72K1J-472JE	1	435034724R1
PCB3	R461	C-CARBON R	RN72K1J-181JE	1	435031814R1
PCB3	R462	C-CARBON R	RN72K1J-181JE	1	435031814R1
PCB3	R463	C-CARBON R	RN72K1J-181JE	1	435031814R1
PCB3	R464	C-CARBON R	RN72K1J-181JE	1	435031814R1
PCB3	R465	C-CARBON R	RN72K1J-181JE	1	435031814R1
PCB3	R466	C-CARBON R	RN72K1J-181JE	1	435031814R1
PCB3	R467	C-CARBON R	RN72K1J-181JE	1	435031814R1
PCB3	R468	C-CARBON R	RN72K1J-181JE	1	435031814R1
PCB3	R471	C-CARBON R	RN72K1J-181JE	1	435031814R1
PCB3	R472	C-CARBON R	RN72K1J-181JE	1	435031814R1
PCB3	R473	C-CARBON R	RN72K1J-181JE	1	435031814R1
PCB3	R474	C-CARBON R	RN72K1J-181JE	1	435031814R1
PCB3	R475	C-CARBON R	RN72K1J-181JE	1	435031814R1
PCB3	R476	C-CARBON R	RN72K1J-181JE	1	435031814R1
PCB3	R477	C-CARBON R	RN72K1J-181JE	1	435031814R1
PCB3	R478	C-CARBON R	RN72K1J-181JE	1	435031814R1
PCB3	R571	C-CARBON R	RN72K1J-000JE	1	435030004R1
PCB3	R572	C-CARBON R	RN72K1J-000JE	1	435030004R1
PCB3	R573	C-CARBON R	RN72K1J-000JE	1	435030004R1
PCB3	R574	C-CARBON R	RN72K1J-000JE	1	435030004R1
PCB3	R575	C-CARBON R	RN72K1J-000JE	1	435030004R1
PCB3	R576	C-CARBON R	RN72K1J-000JE	1	435030004R1
PCB3	R577	C-CARBON R	RN72K1J-000JE	1	435030004R1
PCB3	R578	C-CARBON R	RN72K1J-000JE	1	435030004R1
PCB3	R591	METAL O R	RS1/2WBJ-22	1	443522204T
PCB3	R592	METAL O R	RS1/2WBJ-22	1	443522204T

PCB3	R602	C-CARBON R	RN72K1J-470JE	1	435034704R1
PCB3	R603	C-CARBON R	RN72K1J-103JE	1	435031034R1
PCB3	R604	C-CARBON R	RN72K1J-221JE	1	435032214R1
PCB3	R605	C-CARBON R	RN72K1J-473JE	1	435034734R1
PCB3	R606	C-CARBON R	RN72K1J-000JE	1	435030004R1
PCB3	R607	C-CARBON R	RN72K1J-103JE	1	435031034R1
PCB3	R608	C-CARBON R	RN72K1J-103JE	1	435031034R1
PCB3	R609	C-CARBON R	RN72K1J-105JE	1	435031054R1
PCB3	R610	C-CARBON R	RN72K1J-221JE	1	435032214R1
PCB3	R611	C-CARBON R	RN72K1J-103JE	1	435031034R1
PCB3	R612	C-CARBON R	RN72K1J-221JE	1	435032214R1
PCB3	R613	C-CARBON R	RN72K1J-470JE	1	435034704R1
PCB3	R614	C-CARBON R	RN72K1J-103JE	1	435031034R1
PCB3	R616	C-CARBON R	RN72K1J-470JE	1	435034704R1
PCB3	R617	C-CARBON R	RN72K1J-470JE	1	435034704R1
PCB3	R618	C-CARBON R	RN72K1J-470JE	1	435034704R1
PCB3	R619	C-CARBON R	RN72K1J-470JE	1	435034704R1
PCB3	R620	C-CARBON R	RN72K1J-470JE	1	435034704R1
PCB3	R621	C-CARBON R	RN72K1J-103JE	1	435031034R1
PCB3	R625	C-CARBON R	RN72K1J-470JE	1	435034704R1
PCB3	R627	C-CARBON R	RN72K1J-470JE	1	435034704R1
PCB3	R628	C-CARBON R	RN72K1J-103JE	1	435031034R1
PCB3	R632	C-CARBON R	RN72K1J-103JE	1	435031034R1
PCB3	R637	C-CARBON R	RN72K1J-472JE	1	435034724R1
PCB3	R638	C-CARBON R	RN72K1J-472JE	1	435034724R1
PCB3	R639	C-CARBON R	RN72K1J-272JE	1	435032724R1
PCB3	R640	C-CARBON R	RN72K1J-272JE	1	435032724R1
PCB3	R641	C-CARBON R	RN72K1J-272JE	1	435032724R1
PCB3	R642	C-CARBON R	RN72K1J-272JE	1	435032724R1
PCB3	R643	C-CARBON R	RN72K1J-470JE	1	435034704R1
PCB3	R644	C-CARBON R	RN72K1J-470JE	1	435034704R1
PCB3	R645	C-CARBON R	RN72K1J-102JE	1	435031024R1
PCB3	R646	C-CARBON R	RN72K1J-470JE	1	435034704R1

PCB3	R647	C-CARBON R	RN72K1J-470JE	1	435034704R1	
PCB3	R648	C-CARBON R	RN72K1J-470JE	1	435034704R1	
PCB3	R649	C-CARBON R	RN72K1J-221JE	1	435032214R1	
PCB3	R650	C-CARBON R	RN72K1J-470JE	1	435034704R1	
PCB3	R651	C-CARBON R	RN72K1J-470JE	1	435034704R1	
PCB3	R652	C-CARBON R	RN72K1J-470JE	1	435034704R1	
PCB3	R653	C-CARBON R	RN72K1J-470JE	1	435034704R1	
PCB3	R654	C-CARBON R	RN72K1J-221JE	1	435032214R1	
PCB3	R655	C-CARBON R	RN72K1J-221JE	1	435032214R1	
PCB3	R656	C-CARBON R	RN72K1J-470JE	1	435034704R1	
PCB3	R657	C-CARBON R	RN72K1J-470JE	1	435034704R1	
PCB3	R661	C-CARBON R	RN72K1J-470JE	1	435034704R1	
PCB3	R662	C-CARBON R	RN72K1J-470JE	1	435034704R1	
PCB3	R663	C-CARBON R	RN72K1J-103JE	1	435031034R1	
PCB3	R664	C-CARBON R	RN72K1J-470JE	1	435034704R1	
PCB3	R665	C-CARBON R	RN72K1J-470JE	1	435034704R1	
PCB3	R666	C-CARBON R	RN72K1J-103JE	1	435031034R1	
PCB3	R667	C-CARBON R	RN72K1J-221JE	1	435032214R1	
PCB3	R668	C-CARBON R	RN72K1J-221JE	1	435032214R1	
PCB3	R669	C-CARBON R	RN72K1J-221JE	1	435032214R1	
PCB3	R670	C-CARBON R	RN72K1J-221JE	1	435032214R1	
PCB3	R671	C-CARBON R	RN72K1J-470JE	1	435034704R1	
PCB3	R672	C-CARBON R	RN72K1J-470JE	1	435034704R1	
PCB3	R673	C-CARBON R	RN72K1J-470JE	1	435034704R1	
PCB3	R674	C-CARBON R	RN72K1J-103JE	1	435031034R1	
PCB3	R675	C-CARBON R	RN72K1J-102JE	1	435031024R1	<MPP>
PCB3	R676	C-CARBON R	RN72K1J-105JE	1	435031054R1	
PCB3	R677	C-CARBON R	RN72K1J-221JE	1	435032214R1	
PCB3	R678	C-CARBON R	RN72K1J-221JE	1	435032214R1	
PCB3	R679	C-CARBON R	RN72K1J-103JE	1	435031034R1	
PCB3	R680	C-CARBON R	RN72K1J-103JE	1	435031034R1	
PCB3	R681	C-CARBON R	RN72K1J-103JE	1	435031034R1	
PCB3	R682	C-CARBON R	RN72K1J-103JE	1	435031034R1	

PCB3	R683	C-CARBON R	RN72K1J-103JE	1	435031034R1	
PCB3	R684	C-CARBON R	RN72K1J-000JE	1	435030004R1	
PCB3	R685	C-CARBON R	RN72K1J-000JE	1	435030004R1	
PCB3	R686	C-CARBON R	RN72K1J-103JE	1	435031034R1	
PCB3	R689	C-CARBON R	RN72K1J-470JE	1	435034704R1	
PCB3	R690	C-CARBON R	RN72K1J-470JE	1	435034704R1	
PCB3	R691	C-CARBON R	RN72K1J-470JE	1	435034704R1	
PCB3	R692	C-CARBON R	RN72K1J-470JE	1	435034704R1	
PCB3	R693	C-CARBON R	RN72K1J-102JE	1	435031024R1	<MPP>
PCB3	R695	C-CARBON R	RN72K1J-470JE	1	435034704R1	
PCB3	R696	C-CARBON R	RN72K1J-470JE	1	435034704R1	
PCB3	R697	C-CARBON R	RN72K1J-470JE	1	435034704R1	
PCB3	R698	C-CARBON R	RN72K1J-470JE	1	435034704R1	
PCB3	R699	C-CARBON R	RN72K1J-470JE	1	435034704R1	
PCB3	R700	C-CARBON R	RN72K1J-470JE	1	435034704R1	
PCB3	R701	C-CARBON R	RN72K1J-470JE	1	435034704R1	
PCB3	R703	C-CARBON R	RN72K1J-222JE	1	435032224R1	<MPP>
PCB3	R704	C-CARBON R	RN72K1J-103JE	1	435031034R1	
PCB3	R705	C-CARBON R	RN72K1J-103JE	1	435031034R1	
PCB3	R707	C-CARBON R	RN72K1J-103JE	1	435031034R1	
PCB3	R708	C-CARBON R	RN72K1J-103JE	1	435031034R1	
PCB3	R709	C-CARBON R	RN72K1J-221JE	1	435032214R1	
PCB3	R710	C-CARBON R	RN72K1J-470JE	1	435034704R1	
PCB3	R711	C-CARBON R	RN72K1J-221JE	1	435032214R1	
PCB3	R712	C-CARBON R	RN72K1J-470JE	1	435034704R1	
PCB3	R713	C-CARBON R	RN72K1J-470JE	1	435034704R1	
PCB3	R714	C-CARBON R	RN72K1J-221JE	1	435032214R1	
PCB3	R715	C-CARBON R	RN72K1J-221JE	1	435032214R1	
PCB3	R716	C-CARBON R	RN72K1J-221JE	1	435032214R1	
PCB3	R717	C-CARBON R	RN72K1J-221JE	1	435032214R1	
PCB3	R718	C-CARBON R	RN72K1J-221JE	1	435032214R1	
PCB3	R719	C-CARBON R	RN72K1J-221JE	1	435032214R1	
PCB3	R720	C-CARBON R	RN72K1J-470JE	1	435034704R1	

PCB3	R721	C-CARBON R	RN72K1J-470JE	1	435034704R1	
PCB3	R722	C-CARBON R	RN72K1J-470JE	1	435034704R1	
PCB3	R723	C-CARBON R	RN72K1J-221JE	1	435032214R1	
PCB3	R724	C-CARBON R	RN72K1J-221JE	1	435032214R1	
PCB3	R725	C-CARBON R	RN72K1J-102JE	1	435031024R1	
PCB3	R726	C-CARBON R	RN72K1J-221JE	1	435032214R1	
PCB3	R727	C-CARBON R	RN72K1J-102JE	1	435031024R1	
PCB3	R728	C-CARBON R	RN72K1J-103JE	1	435031034R1	
PCB3	R729	C-CARBON R	RN72K1J-470JE	1	435034704R1	
PCB3	R733	C-CARBON R	RN72K1J-102JE	1	435031024R1	
PCB3	R734	C-CARBON R	RN72K1J-102JE	1	435031024R1	
PCB3	R735	C-CARBON R	RN72K1J-221JE	1	435032214R1	
PCB3	R736	C-CARBON R	RN72K1J-221JE	1	435032214R1	
PCB3	R737	C-CARBON R	RN72K1J-472JE	1	435034724R1	
PCB3	R738	C-CARBON R	RN72K1J-333JE	1	435033334R1	
PCB3	R739	C-CARBON R	RN72K1J-103JE	1	435031034R1	
PCB3	R740	C-CARBON R	RN72K1J-000JE	1	435030004R1	<MDC>
PCB3	R740	C-CARBON R	RN72K1J-103JE	1	435031034R1	<MPP>
PCB3	R741	C-CARBON R	RN72K1J-472JE	1	435034724R1	
PCB3	R742	C-CARBON R	RN72K1J-472JE	1	435034724R1	
PCB3	R743	C-CARBON R	RN72K1J-472JE	1	435034724R1	
PCB3	R744	C-CARBON R	RN72K1J-472JE	1	435034724R1	
PCB3	R745	C-CARBON R	RN72K1J-103JE	1	435031034R1	
PCB3	R746	C-CARBON R	RN72K1J-103JE	1	435031034R1	
PCB3	R747	C-CARBON R	RN72K1J-333JE	1	435033334R1	
PCB3	R748	C-CARBON R	RN72K1J-472JE	1	435034724R1	
PCB3	R749	C-CARBON R	RN72K1J-103JE	1	435031034R1	
PCB3	R750	C-CARBON R	RN72K1J-103JE	1	435031034R1	<MPP>
PCB3	R751	C-CARBON R	RN72K1J-272JE	1	435032724R1	
PCB3	R752	C-CARBON R	RN72K1J-272JE	1	435032724R1	
PCB3	R753	C-CARBON R	RN72K1J-272JE	1	435032724R1	
PCB3	R754	C-CARBON R	RN72K1J-272JE	1	435032724R1	
PCB3	R755	C-CARBON R	RN72K1J-473JE	1	435034734R1	

PCB3	R756	C-CARBON R	RN72K1J-473JE	1	435034734R1	
PCB3	R757	C-CARBON R	RN72K1J-221JE	1	435032214R1	
PCB3	R760	C-CARBON R	RN72K1J-473JE	1	435034734R1	
PCB3	R761	C-CARBON R	RN72K1J-473JE	1	435034734R1	
PCB3	R764	C-CARBON R	RN72K1J-473JE	1	435034734R1	
PCB3	R766	C-CARBON R	RN72K1J-473JE	1	435034734R1	
PCB3	R767	C-CARBON R	RN72K1J-473JE	1	435034734R1	
PCB3	R768	C-CARBON R	RN72K1J-222JE	1	435032224R1	<MPP>
PCB3	R769	C-CARBON R	RN72K1J-103JE	1	435031034R1	
PCB3	R770	C-CARBON R	RN72K1J-103JE	1	435031034R1	
PCB3	R771	C-CARBON R	RN72K1J-273JE	1	435032734R1	
PCB3	R772	C-CARBON R	RN72K1J-101JE	1	435031014R1	
PCB3	R773	C-CARBON R	RN72K1J-101JE	1	435031014R1	
PCB3	R774	C-CARBON R	RN72K1J-224JE	1	435032244R1	
PCB3	R775	C-CARBON R	RN72K1J-103JE	1	435031034R1	
PCB3	R777	C-CARBON R	RN72K1J-272JE	1	435032724R1	
PCB3	R778	C-CARBON R	RN72K1J-272JE	1	435032724R1	
PCB3	R781	C-CARBON R	RN72K1J-272JE	1	435032724R1	
PCB3	R782	C-CARBON R	RN72K1J-103JE	1	435031034R1	
PCB3	R783	C-CARBON R	RN72K1J-103JE	1	435031034R1	
PCB3	R785	C-CARBON R	RN72K1J-103JE	1	435031034R1	
PCB3	R787	C-CARBON R	RN72K1J-222JE	1	435032224R1	
PCB3	R788	C-CARBON R	RN72K1J-103JE	1	435031034R1	
PCB3	R789	C-CARBON R	RN72K1J-103JE	1	435031034R1	
PCB3	R790	C-CARBON R	RN72K1J-473JE	1	435034734R1	
PCB3	R792	C-CARBON R	RN72K1J-222JE	1	435032224R1	
PCB3	R793	C-CARBON R	RN72K1J-102JE	1	435031024R1	
PCB3	P302A	SOCKET	NSCT-15P2195	1	25052298	
PCB3	P303A	SOCKET	NSCT-15P2195	1	25052298	
PCB3	P304A	SOCKET	NSCT-3P2183	1	25052286	
PCB3	P307	PIN JACK	NPJ-2PDO0626	1	25045847	
PCB3	P307 or	PIN JACK	NPJ-2PDO445	(1)	25045640	
PCB3	P602	PVC	#18 1015 BlackL=60mm	1	---	NSP

PCB3	P701A	SOCKET	NSCT-33P2126	1	25052229	
PCB3	P702A	SOCKET	NSCT-9P2427	1	25052530	
PCB3	P708A	SOCKET	NSCT-13P2106	1	25052209	
PCB3	P2004A	PLUG	NPLG-15P0970	1	25056020	
PCB3	P2005A	PLUG	NPLG-15P0970	1	25056020	
PCB3	P8001A	PLUG	IMSA-9111B-16	1	25056620	
PCB3	P8002A	PLUG	IMSA-9111B-16	1	25056620	
PCB3	P8003A	PLUG	IMSA-9111B-16	1	25056620	
PCB3	J101	PVC	1007#24 .2/7HAND B	1	---	NSP
PCB3	JL6402B	WIRE TRAP	NPLG-3P586	1	25055624	
PCB4	U36	VIDEO PC BOARD (NAVD-9467-1N/ 1P)				
PCB4	U37	SPEAKER TERMINAL PC BOARD (NATRM-9468-1N/ 1P)				
PCB4						
PCB4	CIRCUIT NO.	PART NAME	DESCRIPTION	Q'TY	PART NO. (SN)	REMARKS
PCB4	Q3001	IC	AN15880A-VT	1	22242319R3	
PCB4	Q6601	TR	KRC105S	1	2217290R2	
PCB4	Q6601 or	TR	RN1405	(1)	2214500R2	
PCB4	Q6602	TR	KRC105S	1	2217290R2	
PCB4	Q6602 or	TR	RN1405	(1)	2214500R2	
PCB4	Q6603	TR	KRC105S	1	2217290R2	
PCB4	Q6603 or	TR	RN1405	(1)	2214500R2	
PCB4	Q6604	TR	KRC105S	1	2217290R2	
PCB4	Q6604 or	TR	RN1405	(1)	2214500R2	
PCB4	Q9001	TR	2SC2235-Y(TPE6_F)	1	2211654T	
PCB4	Q9001 or	TR	2SC2235-O(TPE6_F)	(1)	2211653T	
PCB4	Q9002	TR	KRC105S	1	2217290R2	
PCB4	Q9002 or	TR	RN1405	(1)	2214500R2	
PCB4	Q9022	IC	MPC2905BHF	1	22278005DBNE	
PCB4	Q9022 or	IC	78M05AHF(MPC78M05AHF)	(1)	222780055NEC	
PCB4	Q9031	IC	MPC2905BHF	1	22278005DBNE	
PCB4	Q9031A	SCREW	3P+10FN(3BC)	1	82143010GR	
PCB4	Q9031B	HEAT SINK	RAD-140	1	27160471	

PCB4	D3028	C-DIODE	KDS4148U	1	223283R2	
PCB4	D3028 or	C-DIODE	1SS352	(1)	223234R2	
PCB4	D3028 or	C-DIODE	MA2J111	(1)	223279R2	
PCB4	D3029	C-DIODE	KDS4148U	1	223283R2	
PCB4	D3029 or	C-DIODE	1SS352	(1)	223234R2	
PCB4	D3029 or	C-DIODE	MA2J111	(1)	223279R2	
PCB4	D6600	C-DIODE	KDS4148U	1	223283R2	
PCB4	D6600 or	C-DIODE	1SS352	(1)	223234R2	
PCB4	D6600 or	C-DIODE	MA2J111	(1)	223279R2	
PCB4	D6603	C-DIODE	KDS4148U	1	223283R2	
PCB4	D6603 or	C-DIODE	1SS352	(1)	223234R2	
PCB4	D6603 or	C-DIODE	MA2J111	(1)	223279R2	
PCB4	D6605	C-DIODE	KDS4148U	1	223283R2	
PCB4	D6605 or	C-DIODE	1SS352	(1)	223234R2	
PCB4	D6605 or	C-DIODE	MA2J111	(1)	223279R2	
PCB4	D6607	C-DIODE	KDS4148U	1	223283R2	
PCB4	D6607 or	C-DIODE	1SS352	(1)	223234R2	
PCB4	D6607 or	C-DIODE	MA2J111	(1)	223279R2	
PCB4	D9001	DIODE	RL1N4003	1	22380260T	
PCB4	D9002	DIODE	RL1N4003	1	22380260T	
PCB4	D9005	ZENER D	UDZS36B	1	224553600R2	
PCB4	D9011	DIODE	D5SBA20	1	22380130	
PCB4	D9011A	SCREW	3P+10FN(3BC)	1	82143010GR	
PCB4	D9011B	HEAT SINK	RAD-083	1	27160271	
PCB4	D9012	C-DIODE	KDS4148U	1	223283R2	
PCB4	D9012 or	C-DIODE	1SS352	(1)	223234R2	
PCB4	D9012 or	C-DIODE	MA2J111	(1)	223279R2	
PCB4	D9013	DIODE	RL1N4003	1	22380260T	
PCB4	D9014	C-DIODE	KDS4148U	1	223283R2	
PCB4	D9014 or	C-DIODE	1SS352	(1)	223234R2	
PCB4	D9014 or	C-DIODE	MA2J111	(1)	223279R2	
PCB4	D9015	C-DIODE	KDS4148U	1	223283R2	
PCB4	D9015 or	C-DIODE	1SS352	(1)	223234R2	

PCB4	D9015 or	C-DIODE	MA2J111	(1)	223279R2	
PCB4	D9016	ZENER D	UDZS7.5B	1	224550750R2	
PCB4	D9017	C-DIODE	KDS4148U	1	223283R2	
PCB4	D9017 or	C-DIODE	1SS352	(1)	223234R2	
PCB4	D9017 or	C-DIODE	MA2J111	(1)	223279R2	
PCB4	D9022	DIODE	RL1N4003	1	22380260T	
PCB4	D9023	C-DIODE	KDS4148U	1	223283R2	
PCB4	D9023 or	C-DIODE	1SS352	(1)	223234R2	
PCB4	D9023 or	C-DIODE	MA2J111	(1)	223279R2	
PCB4	L6600	S COIL	S-1.3C	1	231176S	<MPP>
PCB4	L6601	S COIL	S-1.3C	1	231176S	<MPP>
PCB4	L6602	S COIL	S-1.3C	1	231176S	<MPP>
PCB4	L6603	S COIL	S-1.3C	1	231176S	<MPP>
PCB4	L6604	S COIL	S-1.3C	1	231176S	<MPP>
PCB4	L6605	S COIL	S-1.3C	1	231176S	<MPP>
PCB4	L6606	S COIL	S-1.3C	1	231176S	<MPP>
PCB4	C3001	VR C	CE04W16V-100M(VR)	1	394641017T	
PCB4	C3002	C-CERA C	CK725F1E-104Z1	1	332161040R1	
PCB4	C3003	UTSP C	CE04W50V-22M(UTSP)	1	397582207T	
PCB4	C3004	VR C	CE04W6.3V-470M(VR)	1	394624717T	
PCB4	C3005	C-CERA C	CK725F1E-104Z1	1	332161040R1	
PCB4	C3006	VR C	CE04W16V-100M(VR)	1	394641017T	
PCB4	C3007	VR C	CE04W6.3V-470M(VR)	1	394624717T	
PCB4	C3008	C-CERA C	CK725F1E-104Z1	1	332161040R1	
PCB4	C3009	VR C	CE04W6.3V-470M(VR)	1	394624717T	
PCB4	C3010	C-CERA C	CK725F1E-104Z1	1	332161040R1	
PCB4	C3011	VR C	CE04W6.3V-470M(VR)	1	394624717T	
PCB4	C3012	C-CERA C	CK725F1E-104Z1	1	332161040R1	
PCB4	C3013	VR C	CE04W16V-100M(VR)	1	394641017T	
PCB4	C3014	C-CERA C	CK725F1E-104Z1	1	332161040R1	
PCB4	C3015	C-CERA C	CK725F1E-104Z1	1	332161040R1	
PCB4	C3017	VR C	CE04W6.3V-470M(VR)	1	394624717T	
PCB4	C3018	VR C	CE04W6.3V-470M(VR)	1	394624717T	

PCB4	C3019	C-CERA C	CK725F1E-104Z1	1	332161040R1
PCB4	C3021	VR C	CE04W6.3V-470M(VR)	1	394624717T
PCB4	C3022	VR C	CE04W16V-100M(VR)	1	394641017T
PCB4	C3023	C-CERA C	CK725F1E-104Z1	1	332161040R1
PCB4	C3024	VR C	CE04W6.3V-470M(VR)	1	394624717T
PCB4	C3030	C-CERA C	CK725B1H-102K1	1	332101025R1
PCB4	C3031	C-CERA C	CK725B1H-102K1	1	332101025R1
PCB4	C3032	C-CERA C	CK725B1H-102K1	1	332101025R1
PCB4	C3033	UTSP C	CE04W50V-10M(UTSP)	1	397581007T
PCB4	C3034	UTSP C	CE04W50V-10M(UTSP)	1	397581007T
PCB4	C3035	C-CERA C	CK725F1E-104Z1	1	332161040R1
PCB4	C3036	UTSP C	CE04W50V-10M(UTSP)	1	397581007T
PCB4	C3037	UTSP C	CE04W50V-10M(UTSP)	1	397581007T
PCB4	C3038	C-CERA C	CK725F1E-104Z1	1	332161040R1
PCB4	C3039	C-CERA C	CK725B1H-102K1	1	332101025R1
PCB4	C3040	UTSP C	CE04W50V-10M(UTSP)	1	397581007T
PCB4	C3041	UTSP C	CE04W50V-10M(UTSP)	1	397581007T
PCB4	C3042	C-CERA C	CK725F1E-104Z1	1	332161040R1
PCB4	C3043	C-CERA C	CK725B1H-102K1	1	332101025R1
PCB4	C3044	UTSP C	CE04W50V-1M(UTSP)	1	397580107T
PCB4	C3045	UTSP C	CE04W50V-1M(UTSP)	1	397580107T
PCB4	C3046	UTSP C	CE04W50V-1M(UTSP)	1	397580107T
PCB4	C3047	UTSP C	CE04W50V-1M(UTSP)	1	397580107T
PCB4	C3048	UTSP C	CE04W50V-1M(UTSP)	1	397580107T
PCB4	C3049	UTSP C	CE04W50V-1M(UTSP)	1	397580107T
PCB4	C3050	C-CERA C	CK725B1H-102K1	1	332101025R1
PCB4	C3054	VR C	CE04W6.3V-470M(VR)	1	394624717T
PCB4	C3055	VR C	CE04W6.3V-470M(VR)	1	394624717T
PCB4	C3061	UTSP C	CE04W50V-10M(UTSP)	1	397581007T
PCB4	C3062	C-CERA C	CC725CH1H-101J1	1	342101014R1
PCB4	C3063	C-CERA C	CC725CH1H-101J1	1	342101014R1
PCB4	C3064	C-CERA C	CC725CH1H-101J1	1	342101014R1
PCB4	C3065	C-CERA C	CC725CH1H-101J1	1	342101014R1

PCB4	C3066	C-CERA C	CC725CH1H-101J1	1	342101014R1	
PCB4	C3067	C-CERA C	CC725CH1H-101J1	1	342101014R1	
PCB4	C3068	C-CERA C	CC725CH1H-470J1	1	342104704R1	
PCB4	C3069	C-CERA C	CC725CH1H-470J1	1	342104704R1	
PCB4	C3070	C-CERA C	CC725CH1H-470J1	1	342104704R1	
PCB4	C3084	VR C	CE04W6.3V-470M(VR)	1	394624717T	
PCB4	C3085	VR C	CE04W6.3V-470M(VR)	1	394624717T	
PCB4	C3086	C-CERA C	CK725F1E-104Z1	1	332161040R1	
PCB4	C3090	C-CERA C	CK725B1H-102K1	1	332101025R1	
PCB4	C3091	C-CERA C	CK725B1H-102K1	1	332101025R1	
PCB4	C6600	TF C	ECQ-B50V-103J	1	374721034T	
PCB4	C6602	TF C	ECQ-B50V-103J	1	374721034T	
PCB4	C6603	TF C	ECQ-B50V-103J	1	374721034T	
PCB4	C6605	TF C	ECQ-B50V-103J	1	374721034T	
PCB4	C6607	TF C	ECQ-B50V-103J	1	374721034T	
PCB4	C6640	TF C	ECQ-B50V-103J	1	374721034T	<MPP>
PCB4	C6641	TF C	ECQ-B50V-103J	1	374721034T	<MPP>
PCB4	C6642	TF C	ECQ-B50V-103J	1	374721034T	<MPP>
PCB4	C6643	TF C	ECQ-B50V-103J	1	374721034T	<MPP>
PCB4	C6644	TF C	ECQ-B50V-103J	1	374721034T	<MPP>
PCB4	C6645	TF C	ECQ-B50V-103J	1	374721034T	<MPP>
PCB4	C6646	TF C	ECQ-B50V-103J	1	374721034T	<MPP>
PCB4	C6650	TF C	ECQ-B50V-102J	1	374721024T	<MPP>
PCB4	C6651	TF C	ECQ-B50V-102J	1	374721024T	<MPP>
PCB4	C6652	TF C	ECQ-B50V-102J	1	374721024T	<MPP>
PCB4	C6653	TF C	ECQ-B50V-102J	1	374721024T	<MPP>
PCB4	C6654	TF C	ECQ-B50V-102J	1	374721024T	<MPP>
PCB4	C6655	TF C	ECQ-B50V-102J	1	374721024T	<MPP>
PCB4	C6656	TF C	ECQ-B50V-102J	1	374721024T	<MPP>
PCB4	C9001	VR C	CE04W63V-470M(VR)	1	394674717S	
PCB4	C9005	UTSP C	CE04W50V 47M(UTSP)	1	397584707T	
PCB4	C9006	C-CERA C	CK725F1E-104Z1	1	332161040R1	
PCB4	C9011	VR C	CE04W16V-10000M(VR)	1	394641037S	

PCB4	C9012	TF C	ECQ-V50V-334J	1	374723344T
PCB4	C9013	UTSP C	CE04W50V-2.2M(UTSP)	1	397580227T
PCB4	C9014	UTSP C	CE04W50V-1M(UTSP)	1	397580107T
PCB4	C9023	UTSP C	CE04W50V-10M(UTSP)	1	397581007T
PCB4	C9025	VR C	CE04W6.3V-470M(VR)	1	394624717T
PCB4	C9030	UTSP C	CE04W25V-220M(UTSP)	1	397552217T
PCB4	C9031	C-CERA C	CK725F1E-104Z1	1	332161040R1
PCB4	C9032	VR C	CE04W6.3V-470M(VR)	1	394624717T
PCB4	R3001	C-CARBON R	RN72K1J-000JE	1	435030004R1
PCB4	R3002	C-CARBON R	RN72K1J-000JE	1	435030004R1
PCB4	R3003	C-CARBON R	RN72K1J-000JE	1	435030004R1
PCB4	R3011	C-CARBON R	RN72K1J-750JE	1	435037504R1
PCB4	R3012	C-CARBON R	RN72K1J-750JE	1	435037504R1
PCB4	R3013	C-CARBON R	RN72K1J-750JE	1	435037504R1
PCB4	R3014	C-CARBON R	RN72K1J-750JE	1	435037504R1
PCB4	R3015	C-CARBON R	RN72K1J-750JE	1	435037504R1
PCB4	R3016	C-CARBON R	RN72K1J-750JE	1	435037504R1
PCB4	R3017	C-CARBON R	RN72K1J-750JE	1	435037504R1
PCB4	R3018	C-CARBON R	RN72K1J-750JE	1	435037504R1
PCB4	R3019	C-CARBON R	RN72K1J-750JE	1	435037504R1
PCB4	R3020	C-CARBON R	RN72K1J-750JE	1	435037504R1
PCB4	R3021	C-CARBON R	RN72K1J-750JE	1	435037504R1
PCB4	R3022	C-CARBON R	RN72K1J-750JE	1	435037504R1
PCB4	R3023	C-CARBON R	RN72K1J-750JE	1	435037504R1
PCB4	R3024	C-CARBON R	RN72K1J-750JE	1	435037504R1
PCB4	R3025	C-CARBON R	RN72K1J-750JE	1	435037504R1
PCB4	R3026	C-CARBON R	RN72K1J-750JE	1	435037504R1
PCB4	R3027	C-CARBON R	RN72K1J-750JE	1	435037504R1
PCB4	R3028	C-CARBON R	RN72K1J-750JE	1	435037504R1
PCB4	R3029	C-CARBON R	RN72K1J-750JE	1	435037504R1
PCB4	R3030	C-CARBON R	RN72K1J-750JE	1	435037504R1
PCB4	R3031	C-CARBON R	RN72K1J-750JE	1	435037504R1
PCB4	R3038	METAL R	RNU1/2WCJ-1	1	453530104T

PCB4	R3041	C-CARBON R	RN72K1J-750JE	1	435037504R1	
PCB4	R3042	C-CARBON R	RN72K1J-750JE	1	435037504R1	
PCB4	R3043	C-CARBON R	RN72K1J-750JE	1	435037504R1	
PCB4	R3050	C-CARBON R	RN72K1J-000JE	1	435030004R1	
PCB4	R3051	C-CARBON R	RN72K1J-000JE	1	435030004R1	
PCB4	R3052	C-CARBON R	RN72K1J-000JE	1	435030004R1	
PCB4	R3053	C-CARBON R	RN72K1J-000JE	1	435030004R1	
PCB4	R3054	C-CARBON R	RN72K1J-000JE	1	435030004R1	
PCB4	R3055	C-CARBON R	RN72K1J-000JE	1	435030004R1	
PCB4	R3056	C-CARBON R	RN72K1J-000JE	1	435030004R1	
PCB4	R3057	C-CARBON R	RN72K1J-000JE	1	435030004R1	
PCB4	R3058	C-CARBON R	RN72K1J-000JE	1	435030004R1	
PCB4	R3059	C-CARBON R	RN72K1J-000JE	1	435030004R1	
PCB4	R3060	C-CARBON R	RN72K1J-000JE	1	435030004R1	
PCB4	R3061	C-CARBON R	RN72K1J-000JE	1	435030004R1	
PCB4	R3062	C-CARBON R	RN72K1J-000JE	1	435030004R1	
PCB4	R3063	C-CARBON R	RN72K1J-000JE	1	435030004R1	
PCB4	R3066	C-CARBON R	RN72K1J-000JE	1	435030004R1	
PCB4	R3067	C-CARBON R	RN72K1J-000JE	1	435030004R1	
PCB4	R3068	C-CARBON R	RN72K1J-000JE	1	435030004R1	
PCB4	R3069	C-CARBON R	RN72K1J-000JE	1	435030004R1	
PCB4	R3070	C-CARBON R	RN72K1J-000JE	1	435030004R1	
PCB4	R3071	C-CARBON R	RN72K1J-000JE	1	435030004R1	
PCB4	R3072	C-CARBON R	RN72K1J-000JE	1	435030004R1	
PCB4	R3073	C-CARBON R	RN72K1J-000JE	1	435030004R1	
PCB4	R3074	C-CARBON R	RN72K1J-000JE	1	435030004R1	
PCB4	R3075	C-CARBON R	RN72K1J-000JE	1	435030004R1	
PCB4	R3084	C-CARBON R	RN72K1J-750JE	1	435037504R1	
PCB4	R3085	C-CARBON R	RN72K1J-750JE	1	435037504R1	
PCB4	R3086	C-CARBON R	RN72K1J-750JE	1	435037504R1	
PCB4	R3089	C-CARBON R	RN72K1J-750JE	1	435037504R1	
PCB4	R6600	C-CARBON R	RN72K2E-220JE	1	435222204R1	<MPP>
PCB4	R6601	C-CARBON R	RN72K2E-220JE	1	435222204R1	<MPP>

PCB4	R6602	C-CARBON R	RN72K2E-220JE	1	435222204R1	<MPP>
PCB4	R6603	C-CARBON R	RN72K2E-220JE	1	435222204R1	<MPP>
PCB4	R6604	C-CARBON R	RN72K2E-220JE	1	435222204R1	<MPP>
PCB4	R6605	C-CARBON R	RN72K2E-220JE	1	435222204R1	<MPP>
PCB4	R6606	C-CARBON R	RN72K2E-220JE	1	435222204R1	<MPP>
PCB4	R6610	C-CARBON R	RN72K2E-220JE	1	435222204R1	<MPP>
PCB4	R6611	C-CARBON R	RN72K2E-220JE	1	435222204R1	<MPP>
PCB4	R6612	C-CARBON R	RN72K2E-220JE	1	435222204R1	<MPP>
PCB4	R6613	C-CARBON R	RN72K2E-220JE	1	435222204R1	<MPP>
PCB4	R6614	C-CARBON R	RN72K2E-220JE	1	435222204R1	<MPP>
PCB4	R6615	C-CARBON R	RN72K2E-220JE	1	435222204R1	<MPP>
PCB4	R6616	C-CARBON R	RN72K2E-220JE	1	435222204R1	<MPP>
PCB4	R6690	METAL O R	RS1/2WBJ-33	1	443523304T	<MDC>
PCB4	R6690	METAL O R	RS1/2WBJ-33	1	443523304T	<MPP>
PCB4	R6691	METAL O R	RS1/2WBJ-390	1	443523914T	
PCB4	R6692	METAL O R	RS1/2WBJ-390	1	443523914T	
PCB4	R6693	C-CARBON R	RN72K1J-000JE	1	435030004R1	
PCB4	R9001	METAL O R	RS1WBJ-220	1	443622214T	
PCB4	R9002	C-CARBON R	RN72K1J-822JE	1	435038224R1	
PCB4	R9003	C-CARBON R	RN72K1J-822JE	1	435038224R1	
PCB4	R9004	C-CARBON R	RN72K1J-333JE	1	435033334R1	
PCB4	R9011	METAL R	RNU1/2WCJ-4.7	1	453530474T	
PCB4	R9012	METAL R	RNU1/2WCJ-1	1	453530104T	
PCB4	R9013	METAL R	RNU1/2WCJ-1	1	453530104T	
PCB4	R9014	C-CARBON R	RN72K1J-104JE	1	435031044R1	
PCB4	R9029	METAL R	RNU1WCJ-0.22	1	453632294T	
PCB4	R9030	METAL O R	RS2WBJ-22	1	442722204F	
PCB4	R9031	METAL R	RNU2WCJ-3.3	1	452730334F	
PCB4	R9032	METAL R	RNU2WCJ-3.3	1	452730334F	
PCB4	R9033	METAL R	RNU1/2WCJ-1	1	453530104T	
PCB4	R9035	METAL R	RNU1/2WCJ-1	1	453530104T	
PCB4	R9036	C-CARBON R	RN72K1J-000JE	1	435030004R1	
PCB4	RL6600	RELAY	NRL-2P5A-DC24-129	1	25065563A	

PCB4	RL6600 or	RELAY	NRL-2P5A-DC24-158	(1)	25065618
PCB4	RL6600 or	RELAY	NRL-2P5A-DC24-193	(1)	25065703
PCB4	RL6602	RELAY	NRL-2P5A-DC24-129	1	25065563A
PCB4	RL6602 or	RELAY	NRL-2P5A-DC24-158	(1)	25065618
PCB4	RL6602 or	RELAY	NRL-2P5A-DC24-193	(1)	25065703
PCB4	RL6603	RELAY	NRL-2P5A-DC24-129	1	25065563A
PCB4	RL6603 or	RELAY	NRL-2P5A-DC24-158	(1)	25065618
PCB4	RL6603 or	RELAY	NRL-2P5A-DC24-193	(1)	25065703
PCB4	RL6605	RELAY	NRL-2P5A-DC24-129	1	25065563A
PCB4	RL6605 or	RELAY	NRL-2P5A-DC24-158	(1)	25065618
PCB4	RL6605 or	RELAY	NRL-2P5A-DC24-193	(1)	25065703
PCB4	RL6607	RELAY	NRL-2P5A-DC24-129	1	25065563A
PCB4	RL6607 or	RELAY	NRL-2P5A-DC24-158	(1)	25065618
PCB4	RL6607 or	RELAY	NRL-2P5A-DC24-193	(1)	25065703
PCB4	P2004B	SOCKET	NSCT-15P2195	1	25052298
PCB4	P2005B	SOCKET	NSCT-15P2195	1	25052298
PCB4	P2801A	SOCKET	NSCT-13P2106	1	25052209
PCB4	P3001	PIN JACK	NPJ-10PDBY621	1	25045842
PCB4	P3001 or	PIN JACK	NPJ-10PDBY478	(1)	25045681
PCB4	P3002	PIN JACK	NPJ-5PDBY622	1	25045843
PCB4	P3002 or	PIN JACK	NPJ-5PDBY479	(1)	25045682
PCB4	P3003	PIN JACK	NPJ-10PDBY621	1	25045842
PCB4	P3003 or	PIN JACK	NPJ-10PDBY478	(1)	25045681
PCB4	P3005	PIN JACK	NPJ-9PDGLRGLRGLR563	1	25045781
PCB4	P3005 or	PIN JACK	NPJ-9PDGLR519	(1)	25045731
PCB4	P6601	TRM	NTM-2PDMCR400	1	25060472
PCB4	P6602	TRM	NTM-4PDMNRR420	1	25060492
PCB4	P6603	TRM	NTM-4PDMNRR420	1	25060492
PCB4	P6604	TRM	NTM-4PDMNRR420	1	25060492
PCB4	E9001	TRM-423(SCREW)	NEJITANSI ST3	1	25060495
PCB4	E9002	RETAINER	(JOINT)	1	27142069
PCB4	JL6600B	SOCKET	NSCT-7P99	1	25050271
PCB4	JL6603B	SOCKET	NSCT-9P101	1	25050273

PCB4	JL6604B	SOCKET	NSCT-5P97	1	25050269	
PCB4	JL6605B	SOCKET	NSCT-5P97	1	25050269	
PCB4	JL8001	JUMPER LEAD	JL5 100 B	1	---	NSP
PCB4	JL8001A	WIRE HOL	NSCT-5P876	1	25051089	
PCB4	JL901B	WIRE TRAP	NPLG-5P588	1	25055626	
PCB4	JL9101B	SOCKET	NSCT-7P99	1	25050271	
PCB4	JL9102	JUMPER LEAD	JL7 150 UL2651#24	1	---	NSP
PCB4	JL9102A	WIRE HOL	NSCT-7P878	1	25051091	
PCB4	JL9102B	WIRE HOL	NSCT-7P878	1	25051091	
PCB5	U41	HDMI PC BOARD (NAHDM- 9473-1A)				
PCB5						
PCB5	CIRCUIT NO.	PART NAME	DESCRIPTION	Q'TY	PART NO. (SN)	REMARKS
PCB5	Q201	IC	D788E001BRFP266	1	22242502R3	NSP
PCB5	Q202	IC	TC74VHC157FT	1	22274157ER2TO	
PCB5	Q203	IC	TC7WU04FU(TE12L_F)	1	22240935R2	
PCB5	Q205	IC	TC74VHC541FT(EKJ)	1	22274541E1R2TO	
PCB5	Q271	IC	SI8008TM	1	22242323R2	
PCB5	Q272	IC	TA48033AF(TE16L_NQ)	1	22278033DR2TO	
PCB5	Q272 or	IC	NJM2391DL1-33	(1)	22278033DR2JR	
PCB5	Q272 or	IC	TA48033BF(TE16L_NQ)	(1)	22278033DBR2TO	
PCB5	Q272 or	IC	BA33BC0FP	(1)	22278033DR2RH	
PCB5	Q273	IC	BD7820	1	22242300R2	
PCB5	Q281	IC	M12L64164A-7TG	1	22242441R3	
PCB5	Q281 or	IC	K4S641632K-UC60	(1)	22242462R2	
PCB5	Q282	IC (DSP ROM)	ES29LV160ET-70TG (0277)	1	222W0069R302776	
PCB5	Q282 or	IC (DSP ROM)	S29AL016D70TFI010 (0277)	(1)	222W0063R302776	
PCB5	Q8001	IC	FLI30502	1	22242481R3	NSP
PCB5	Q8002	IC	TC74VCX162244FT(EL_F)	1	2227C244DR2TO	
PCB5	Q8003	IC	TC74VCX162244FT(EL_F)	1	2227C244DR2TO	
PCB5	Q8005	IC	TA48033AF(TE16L_NQ)	1	22278033DR2TO	
PCB5	Q8005 or	IC	TA48033BF(TE16L_NQ)	(1)	22278033DBR2TO	
PCB5	Q8006	IC	SI8008TM	1	22242323R2	

PCB5	Q8007	IC	TA48033AF(TE16L_NQ)	1	22278033DR2TO
PCB5	Q8007 or	IC	TA48033BF(TE16L_NQ)	(1)	22278033DBR2TO
PCB5	Q8008	IC	TA48018AF(TE16L_NQ)	1	22278018DR2TO
PCB5	Q8008 or	IC	BA18BC0FP	(1)	22278018DR2RH
PCB5	Q8009	IC	XC6213B182MR	1	22242443R2
PCB5	Q8080	IC	S-24CS16A0I-J8V1G	1	22242326R2
PCB5	Q8081	IC	74LCX74MTCX_F40	1	22242483R2
PCB5	Q8082	IC	NC7SZ08P5X_F042	1	22242482R2
PCB5	Q8085	IC (VIDEO)	SST25VF016B (0262)	1	222W0081R20262A
PCB5	Q8090	TR	RN2402	1	2214530R2
PCB5	Q8090 or	TR	KRA102S	(1)	2216220R2
PCB5	Q8091	TR	2SA1162-GR	1	2214375R2
PCB5	Q8161	IC	TA48018AF(TE16L_NQ)	1	22278018DR2TO
PCB5	Q8161 or	IC	BA18BC0FP	(1)	22278018DR2RH
PCB5	Q8162	IC	SII9185ACTU	1	22242471R3
PCB5	Q8305	IC	S-812C50BUC-C5ET2G	1	22242407R2
PCB5	Q8306	IC	NC7SZ08P5X_F042	1	22242482R2
PCB5	Q8306 or	IC	TC7SZ08FU(TE85L_F)	(1)	22242071R2TO
PCB5	Q8309	IC	SN74CB3T3306DCT	1	22242454R2
PCB5	Q8401	IC	SII9134CTU	1	22242394R3
PCB5	Q8404	IC	XC6213B182MR	1	22242443R2
PCB5	Q8405	IC	SN74CB3Q3305PWR	1	22242258R2
PCB5	Q8501	IC	SII9135CTU	1	22242393R3
PCB5	Q8501 or	IC	SII9135ACTU	(1)	22242576R3
PCB5	Q8593	IC	SI8008TM	1	22242323R2
PCB5	Q8595	IC	TA48018AF(TE16L_NQ)	1	22278018DR2TO
PCB5	Q8595 or	IC	BA18BC0FP	(1)	22278018DR2RH
PCB5	Q8604	TR	DTA144EE	1	2216380R2
PCB5	Q8606	TR	DTC144EE	1	2216390R2
PCB5	Q8607	TR	2SK3019	1	2216520R2
PCB5	Q8608	IC	SN74CB3T3306DCT	1	22242454R2
PCB5	Q8609	TR	DTC144EE	1	2216390R2
PCB5	Q8610	IC	S-24CS02AFT-V-G	1	22242360R2

PCB5	Q8610 or	IC	BR24L02FV-W	(1)	22242069R2
PCB5	Q8651	IC	TA48018AF(TE16L_NQ)	1	22278018DR2TO
PCB5	Q8651 or	IC	BA18BC0FP	(1)	22278018DR2RH
PCB5	Q8652	IC	XC6213B332MR	1	22242277R2
PCB5	Q8653	IC	TA48033AF(TE16L_NQ)	1	22278033DR2TO
PCB5	Q8653 or	IC	NJM2391DL1-33	(1)	22278033DR2JR
PCB5	Q8653 or	IC	TA48033BF(TE16L_NQ)	(1)	22278033DBR2TO
PCB5	Q8653 or	IC	BA33BC0FP	(1)	22278033DR2RH
PCB5	Q8654	IC	TA48018AF(TE16L_NQ)	1	22278018DR2TO
PCB5	Q8654 or	IC	BA18BC0FP	(1)	22278018DR2RH
PCB5	D201	DIODE	RB070M-30	1	22380361R2
PCB5	D201 or	C-DIODE	CRS09(TE85L_Q)	(1)	223274R2
PCB5	D203	C-DIODE	1SR154-400	1	22380284R2
PCB5	D204	C-DIODE	KDS4148U	1	223283R2
PCB5	D204 or	C-DIODE	1SS352	(1)	223234R2
PCB5	D204 or	C-DIODE	MA2J111	(1)	223279R2
PCB5	D205	C-DIODE	1SR154-400	1	22380284R2
PCB5	D8001	DIODE	RB070M-30	1	22380361R2
PCB5	D8001 or	C-DIODE	CRS09(TE85L_Q)	(1)	223274R2
PCB5	D8090	C-DIODE	KDS4148U	1	223283R2
PCB5	D8090 or	C-DIODE	1SS352	(1)	223234R2
PCB5	D8090 or	C-DIODE	MA2J111	(1)	223279R2
PCB5	D8091	C-DIODE	KDS4148U	1	223283R2
PCB5	D8091 or	C-DIODE	1SS352	(1)	223234R2
PCB5	D8091 or	C-DIODE	MA2J111	(1)	223279R2
PCB5	D8301	DIODE	DAN217T146	1	223285R2
PCB5	D8301 or	C-DIODE	1SS226(TE85L_F)	(1)	223266R2
PCB5	D8302	C-DIODE	KDS4148U	1	223283R2
PCB5	D8302 or	C-DIODE	1SS352	(1)	223234R2
PCB5	D8302 or	C-DIODE	MA2J111	(1)	223279R2
PCB5	D8591	DIODE	RB070M-30	1	22380361R2
PCB5	D8591 or	C-DIODE	CRS09(TE85L_Q)	(1)	223274R2
PCB5	D8601	ZENER D	MAZ8036	1	224750360R2

PCB5	D8601 or	ZENER D	UDZS3.6B	(1)	224550360R2
PCB5	X201	CRYSTAL	HC-49USSMD17.734MHz	1	3010442R2
PCB5	X201A	CUSHION	(BUTYL)	1	28141748
PCB5	X8001	CRYSTAL	FCX-03-19.6608M	1	3010439R2
PCB5	X8501	CRYSTAL	HC-49-28.332MHz	1	3010417R2
PCB5	L201	CHOKE COIL	BLM21PG221SN1	1	230949R2
PCB5	L202	CHOKE COIL	BLM21PG221SN1	1	230949R2
PCB5	L203	C-CARBON R	RN72K1J-000JE	1	435030004R1
PCB5	L204	EMIFIL	BK1608LM182-T	1	230958R1
PCB5	L205	CHOKE COIL	LBC2518T470M	1	231364M470R2
PCB5	L206	EMIFIL	BK1608LM182-T	1	230958R1
PCB5	L219	CHOKE COIL	BLM21PG221SN1	1	230949R2
PCB5	L241	EMIFIL	ACF451832-333-T	1	230978R2
PCB5	L251	CHOKE COIL	BLM21PG221SN1	1	230949R2
PCB5	L261	EMIFIL	BK1608LL241-T	1	230959R1
PCB5	L271	CHOKE COIL	NCH-2541	1	231363K470A
PCB5	L271 or	COIL	0182-7310-470K-RB	(1)	231389
PCB5	L281	CHOKE COIL	BLM21PG221SN1	1	230949R2
PCB5	L282	CHOKE COIL	BLM21PG221SN1	1	230949R2
PCB5	L283	CHOKE COIL	BLM21PG221SN1	1	230949R2
PCB5	L8001	CHOKE COIL	BLM21PG221SN1	1	230949R2
PCB5	L8002	CHOKE COIL	LBC2518T4R7M	1	231364M047R2
PCB5	L8003	CHOKE COIL	LBC2518T4R7M	1	231364M047R2
PCB5	L8004	CHOKE COIL	BLM21PG221SN1	1	230949R2
PCB5	L8005	CHOKE COIL	BLM21PG221SN1	1	230949R2
PCB5	L8006	CHOKE COIL	LBC2518T4R7M	1	231364M047R2
PCB5	L8007	CHOKE COIL	LBC2518T4R7M	1	231364M047R2
PCB5	L8008	CHOKE COIL	LBC2518T4R7M	1	231364M047R2
PCB5	L8010	CHOKE COIL	BLM21PG221SN1	1	230949R2
PCB5	L8012	CHOKE COIL	BLM21PG221SN1	1	230949R2
PCB5	L8013	CHOKE COIL	BLM21PG221SN1	1	230949R2
PCB5	L8014	CHOKE COIL	NCH-2541	1	231363K470A
PCB5	L8014 or	COIL	0182-7310-470K-RB	(1)	231389

PCB5	L8015	CHOKO COIL	BLM21PG221SN1	1	230949R2
PCB5	L8019	EMIFIL	BK1608LL241-T	1	230959R1
PCB5	L8070	CHOKO COIL	LBC2518T4R7M	1	231364M047R2
PCB5	L8090	CHOKO COIL	LBC2518T4R7M	1	231364M047R2
PCB5	L8161	CHOKO COIL	BLM21PG221SN1	1	230949R2
PCB5	L8162	CHOKO COIL	BLM21PG221SN1	1	230949R2
PCB5	L8163	CHOKO COIL	BLM21PG221SN1	1	230949R2
PCB5	L8401	CHOKO COIL	BLM21PG221SN1	1	230949R2
PCB5	L8402	CHOKO COIL	BLM21PG221SN1	1	230949R2
PCB5	L8403	CHOKO COIL	BLM21PG221SN1	1	230949R2
PCB5	L8404	CHOKO COIL	BLM21PG221SN1	1	230949R2
PCB5	L8405	CHOKO COIL	BLM21PG221SN1	1	230949R2
PCB5	L8406	C-R NET	MNR12E0APJ000	1	43464900002R2
PCB5	L8407	C-R NET	MNR12E0APJ000	1	43464900002R2
PCB5	L8408	CHOKO COIL	BLM21PG221SN1	1	230949R2
PCB5	L8409	C-R NET	MNR12E0APJ000	1	43464900002R2
PCB5	L8410	C-R NET	MNR12E0APJ000	1	43464900002R2
PCB5	L8505	CHOKO COIL	BLM21PG221SN1	1	230949R2
PCB5	L8507	CHOKO COIL	NCH-2541	1	231363K470A
PCB5	L8507 or	COIL	0182-7310-470K-RB	(1)	231389
PCB5	L8508	CHOKO COIL	BLM21PG221SN1	1	230949R2
PCB5	L8601	CHOKO COIL	BLM21PG221SN1	1	230949R2
PCB5	L8602	CHOKO COIL	BLM21PG221SN1	1	230949R2
PCB5	L8603	CHOKO COIL	BLM21PG221SN1	1	230949R2
PCB5	L8604	CHOKO COIL	BLM21PG221SN1	1	230949R2
PCB5	L8605	CHOKO COIL	BLM21PG221SN1	1	230949R2
PCB5	L8606	CHOKO COIL	BLM21PG221SN1	1	230949R2
PCB5	L8607	CHOKO COIL	BLM21PG221SN1	1	230949R2
PCB5	L8608	EMIFIL	BK1608LM182-T	1	230958R1
PCB5	C201	C-CERA C	CK725F1E-104Z1	1	332161040R1
PCB5	C202	C-CERA C	CK725F1E-104Z1	1	332161040R1
PCB5	C203	C-CERA C	CK725F1E-104Z1	1	332161040R1
PCB5	C204	C-CERA C	CK725F1E-104Z1	1	332161040R1

PCB5	C205	C-CERA C	CK725F1E-104Z1	1	332161040R1
PCB5	C206	C-CERA C	CK725F1E-104Z1	1	332161040R1
PCB5	C207	C-CERA C	CK725F1E-104Z1	1	332161040R1
PCB5	C208	C-CERA C	CK725F1E-104Z1	1	332161040R1
PCB5	C209	C-CERA C	CK725F1E-104Z1	1	332161040R1
PCB5	C210	C-CERA C	CK725F1E-104Z1	1	332161040R1
PCB5	C211	C-CERA C	CK725F1E-104Z1	1	332161040R1
PCB5	C212	C-CERA C	CK725F1E-104Z1	1	332161040R1
PCB5	C213	C-CERA C	CK725F1E-104Z1	1	332161040R1
PCB5	C214	C-CERA C	CK725F1E-104Z1	1	332161040R1
PCB5	C215	C-CERA C	CK725F1E-104Z1	1	332161040R1
PCB5	C216	C-CERA C	CK725F1E-104Z1	1	332161040R1
PCB5	C217	C-CERA C	CK725F1E-104Z1	1	332161040R1
PCB5	C218	CHIP ELECT C	CEWX4V-220M	1	3981G2217R2
PCB5	C219	C-CERA C	CK725F1A-105Z1	1	332181050R1
PCB5	C220	C-CERA C	CK725F1E-104Z1	1	332161040R1
PCB5	C221	C-CERA C	CK725F1E-104Z1	1	332161040R1
PCB5	C222	C-CERA C	CK725F1E-104Z1	1	332161040R1
PCB5	C223	C-CERA C	CK725F1E-104Z1	1	332161040R1
PCB5	C224	C-CERA C	CK725F1E-104Z1	1	332161040R1
PCB5	C225	C-CERA C	CK725F1E-104Z1	1	332161040R1
PCB5	C226	C-CERA C	CK725F1E-104Z1	1	332161040R1
PCB5	C227	C-CERA C	CK725F1E-104Z1	1	332161040R1
PCB5	C228	C-CERA C	CK725F1E-104Z1	1	332161040R1
PCB5	C229	C-CERA C	CK725F1E-104Z1	1	332161040R1
PCB5	C230	C-CERA C	CK725F1E-104Z1	1	332161040R1
PCB5	C231	C-CERA C	CK725F1E-104Z1	1	332161040R1
PCB5	C232	C-CERA C	CK725F1E-104Z1	1	332161040R1
PCB5	C233	C-CERA C	CK725F1E-104Z1	1	332161040R1
PCB5	C234	C-CERA C	CK725F1E-104Z1	1	332161040R1
PCB5	C235	CHIP ELECT C	CEWX4V-220M	1	3981G2217R2
PCB5	C238	C-CERA C	CC725CH1H-060D1	1	342100602R1
PCB5	C239	C-CERA C	CC725CH1H-060D1	1	342100602R1

PCB5	C241	CHIP ELECT C	CEWX4V-220M	1	3981G2217R2
PCB5	C242	C-CERA C	CK725F1E-104Z1	1	332161040R1
PCB5	C243	C-CERA C	CC725CH1H-101J1	1	342101014R1
PCB5	C244	C-CERA C	CK725F1E-104Z1	1	332161040R1
PCB5	C245	C-CERA C	CK725F1E-104Z1	1	332161040R1
PCB5	C246	C-CERA C	CK725F1E-104Z1	1	332161040R1
PCB5	C247	C-CERA C	CK725F1E-104Z1	1	332161040R1
PCB5	C251	C-CERA C	CK725F1A-105Z1	1	332181050R1
PCB5	C252	C-CERA C	CK725F1E-104Z1	1	332161040R1
PCB5	C270	CHIP ELECT C	CEWX4V-22M	1	3981G2207R2
PCB5	C271	CD C	UCD1E221MNL1GS	1	396652217R2
PCB5	C272	C-CERA C	CK725B1H-223K1	1	332102235R1
PCB5	C273	C-CERA C	CK725F1E-104Z1	1	332161040R1
PCB5	C274	CD C	UCD1A471MNL1GS	1	396634717R2
PCB5	C275	C-CERA C	CK725F1E-104Z1	1	332161040R1
PCB5	C276	CHIP ELECT C	CEWX4V-100M	1	3981G1017R2
PCB5	C277	C-CERA C	CK725F1E-104Z1	1	332161040R1
PCB5	C278	CHIP ELECT C	CEWX4V-100M	1	3981G1017R2
PCB5	C279	C-CERA C	CK725F1E-104Z1	1	332161040R1
PCB5	C281	CHIP ELECT C	CEWX4V-220M	1	3981G2217R2
PCB5	C282	C-CERA C	CK725F1E-104Z1	1	332161040R1
PCB5	C283	C-CERA C	CC725CH1H-102J1	1	342101024R1
PCB5	C284	CHIP ELECT C	CEWX4V-220M	1	3981G2217R2
PCB5	C285	C-CERA C	CK725F1E-104Z1	1	332161040R1
PCB5	C286	C-CERA C	CK725F1E-104Z1	1	332161040R1
PCB5	C287	C-CERA C	CK725F1E-104Z1	1	332161040R1
PCB5	C288	C-CERA C	CK725F1E-104Z1	1	332161040R1
PCB5	C289	C-CERA C	CK725F1E-104Z1	1	332161040R1
PCB5	C290	C-CERA C	CK725F1E-104Z1	1	332161040R1
PCB5	C291	C-CERA C	CK725F1E-104Z1	1	332161040R1
PCB5	C292	C-CERA C	CK725F1E-104Z1	1	332161040R1
PCB5	C295	C-CERA C	CK725F1E-104Z1	1	332161040R1
PCB5	C8001	CHIP ELECT C	CEWX4V-22M	1	3981G2207R2

PCB5	C8002	C-CERA C	CK725F1E-104Z1	1	332161040R1
PCB5	C8003	C-CERA C	CK725B1H-103K1	1	332101035R1
PCB5	C8004	C-CERA C	CK725F1E-104Z1	1	332161040R1
PCB5	C8005	CHIP ELECT C	CEWX4V-22M	1	3981G2207R2
PCB5	C8006	C-CERA C	CC725CH1H-120J1	1	342101204R1
PCB5	C8007	C-CERA C	CC725CH1H-120J1	1	342101204R1
PCB5	C8008	C-CERA C	CK725F1E-104Z1	1	332161040R1
PCB5	C8009	C-CERA C	CK725F1E-104Z1	1	332161040R1
PCB5	C8010	C-CERA C	CK725F1E-104Z1	1	332161040R1
PCB5	C8011	CHIP ELECT C	CEWX4V-22M	1	3981G2207R2
PCB5	C8012	C-CERA C	CK725F1E-104Z1	1	332161040R1
PCB5	C8013	C-CERA C	CK725F1E-104Z1	1	332161040R1
PCB5	C8014	C-CERA C	CK725F1E-104Z1	1	332161040R1
PCB5	C8015	C-CERA C	CK725F1E-104Z1	1	332161040R1
PCB5	C8016	C-CERA C	CK725F1E-104Z1	1	332161040R1
PCB5	C8017	C-CERA C	CK725F1E-104Z1	1	332161040R1
PCB5	C8018	C-CERA C	CK725F1E-104Z1	1	332161040R1
PCB5	C8019	C-CERA C	CK725F1E-104Z1	1	332161040R1
PCB5	C8021	C-CERA C	CK725F1E-104Z1	1	332161040R1
PCB5	C8023	C-CERA C	CK725F1E-104Z1	1	332161040R1
PCB5	C8024	C-CERA C	CK725F1E-104Z1	1	332161040R1
PCB5	C8025	C-CERA C	CK725F1E-104Z1	1	332161040R1
PCB5	C8026	CHIP ELECT C	CEWX4V-22M	1	3981G2207R2
PCB5	C8027	CHIP ELECT C	CEWX4V-22M	1	3981G2207R2
PCB5	C8028	C-CERA C	CK725F1E-104Z1	1	332161040R1
PCB5	C8029	C-CERA C	CK725F1E-104Z1	1	332161040R1
PCB5	C8030	C-CERA C	CK725F1E-104Z1	1	332161040R1
PCB5	C8031	C-CERA C	CK725F1E-104Z1	1	332161040R1
PCB5	C8032	C-CERA C	CK725F1E-104Z1	1	332161040R1
PCB5	C8033	C-CERA C	CK725F1E-104Z1	1	332161040R1
PCB5	C8034	C-CERA C	CK725F1E-104Z1	1	332161040R1
PCB5	C8035	CHIP ELECT C	CEWX4V-22M	1	3981G2207R2
PCB5	C8036	CHIP ELECT C	CEWX4V-22M	1	3981G2207R2

PCB5	C8037	CHIP ELECT C	CEWX4V-22M	1	3981G2207R2
PCB5	C8038	C-CERA C	CK725F1E-104Z1	1	332161040R1
PCB5	C8039	C-CERA C	CK725F1E-104Z1	1	332161040R1
PCB5	C8040	C-CERA C	CK725F1E-104Z1	1	332161040R1
PCB5	C8041	C-CERA C	CK725F1E-104Z1	1	332161040R1
PCB5	C8042	C-CERA C	CK725F1E-104Z1	1	332161040R1
PCB5	C8043	C-CERA C	CK725F1E-104Z1	1	332161040R1
PCB5	C8044	C-CERA C	CK725F1E-104Z1	1	332161040R1
PCB5	C8045	C-CERA C	CK725F1E-104Z1	1	332161040R1
PCB5	C8046	C-CERA C	CK725F1E-104Z1	1	332161040R1
PCB5	C8047	C-CERA C	CK725F1E-104Z1	1	332161040R1
PCB5	C8048	C-CERA C	CK725F1E-104Z1	1	332161040R1
PCB5	C8049	C-CERA C	CK725F1E-104Z1	1	332161040R1
PCB5	C8050	C-CERA C	CK725F1E-104Z1	1	332161040R1
PCB5	C8051	C-CERA C	CK725F1E-104Z1	1	332161040R1
PCB5	C8052	C-CERA C	CK725F1E-104Z1	1	332161040R1
PCB5	C8053	C-CERA C	CK725F1E-104Z1	1	332161040R1
PCB5	C8054	C-CERA C	CK725F1E-104Z1	1	332161040R1
PCB5	C8055	C-CERA C	CK725F1E-104Z1	1	332161040R1
PCB5	C8056	C-CERA C	CK725F1E-104Z1	1	332161040R1
PCB5	C8057	C-CERA C	CK725F1E-104Z1	1	332161040R1
PCB5	C8058	C-CERA C	CK725F1E-104Z1	1	332161040R1
PCB5	C8059	C-CERA C	CK725F1E-104Z1	1	332161040R1
PCB5	C8060	C-CERA C	CK725F1E-104Z1	1	332161040R1
PCB5	C8061	C-CERA C	CK725F1E-104Z1	1	332161040R1
PCB5	C8062	C-CERA C	CK725F1E-104Z1	1	332161040R1
PCB5	C8063	C-CERA C	CK725F1E-104Z1	1	332161040R1
PCB5	C8064	C-CERA C	CK725F1E-104Z1	1	332161040R1
PCB5	C8065	C-CERA C	CK725F1E-104Z1	1	332161040R1
PCB5	C8066	C-CERA C	CK725F1E-104Z1	1	332161040R1
PCB5	C8067	C-CERA C	CK725F1E-104Z1	1	332161040R1
PCB5	C8068	C-CERA C	CK725F1E-104Z1	1	332161040R1
PCB5	C8069	C-CERA C	CK725F1E-104Z1	1	332161040R1

PCB5	C8070	CHIP ELECT C	CEWX4V-22M	1	3981G2207R2
PCB5	C8071	C-CERA C	CK725F1E-104Z1	1	332161040R1
PCB5	C8072	CHIP ELECT C	CEWX4V-100M	1	3981G1017R2
PCB5	C8073	C-CERA C	CK725F1E-104Z1	1	332161040R1
PCB5	C8075	CD C	UCD1A471MNL1GS	1	396634717R2
PCB5	C8076	CD C	UCD1E221MNL1GS	1	396652217R2
PCB5	C8077	C-CERA C	CK725B1H-223K1	1	332102235R1
PCB5	C8078	C-CERA C	CK725F1E-104Z1	1	332161040R1
PCB5	C8080	C-CERA C	CK725F1E-104Z1	1	332161040R1
PCB5	C8082	C-CERA C	CK725F1E-104Z1	1	332161040R1
PCB5	C8083	C-CERA C	CK725F1E-104Z1	1	332161040R1
PCB5	C8084	CHIP ELECT C	CEWX4V-100M	1	3981G1017R2
PCB5	C8085	C-CERA C	CK725F1E-104Z1	1	332161040R1
PCB5	C8086	C-CERA C	CK725F1E-104Z1	1	332161040R1
PCB5	C8087	C-CERA C	CK725F1E-104Z1	1	332161040R1
PCB5	C8088	CHIP ELECT C	CEWX4V-22M	1	3981G2207R2
PCB5	C8089	C-CERA C	CK725F1E-104Z1	1	332161040R1
PCB5	C8090	C-CERA C	CK725F1E-104Z1	1	332161040R1
PCB5	C8091	C-CERA C	CK725F1E-104Z1	1	332161040R1
PCB5	C8092	C-CERA C	CK725F1E-104Z1	1	332161040R1
PCB5	C8093	C-CERA C	CK725F1E-104Z1	1	332161040R1
PCB5	C8094	CHIP ELECT C	CEWX4V-220M	1	3981G2217R2
PCB5	C8095	C-CERA C	CK725F1E-104Z1	1	332161040R1
PCB5	C8096	CHIP ELECT C	CEWX4V-100M	1	3981G1017R2
PCB5	C8097	CHIP ELECT C	CEWX4V-220M	1	3981G2217R2
PCB5	C8098	C-CERA C	CK725F1A-105Z1	1	332181050R1
PCB5	C8099	C-CERA C	CK725F1A-105Z1	1	332181050R1
PCB5	C8101	C-CARBON R	RN72K1J-022JE	1	435030224R1
PCB5	C8102	C-CERA C	CK725B1H-102K1	1	332101025R1
PCB5	C8103	C-CERA C	CK725F1E-104Z1	1	332161040R1
PCB5	C8104	C-CERA C	CK725F1E-104Z1	1	332161040R1
PCB5	C8105	C-CERA C	CK725F1E-104Z1	1	332161040R1
PCB5	C8106	C-CERA C	CK725F1E-104Z1	1	332161040R1

PCB5	C8107	C-CERA C	CK725F1E-104Z1	1	332161040R1
PCB5	C8121	C-CERA C	CK725B1H-102K1	1	332101025R1
PCB5	C8122	C-CERA C	CK725B1H-102K1	1	332101025R1
PCB5	C8141	C-CERA C	CK725B1H-102K1	1	332101025R1
PCB5	C8142	C-CERA C	CK725B1H-102K1	1	332101025R1
PCB5	C8161	C-CERA C	CK725F1E-104Z1	1	332161040R1
PCB5	C8162	CHIP ELECT C	CEWX4V-100M	1	3981G1017R2
PCB5	C8163	C-CERA C	CK725B1H-102K1	1	332101025R1
PCB5	C8164	CHIP ELECT C	CEWX4V-22M	1	3981G2207R2
PCB5	C8165	C-CERA C	CK725F1E-104Z1	1	332161040R1
PCB5	C8166	CHIP ELECT C	CEWX4V-22M	1	3981G2207R2
PCB5	C8167	C-CERA C	CK725F1E-104Z1	1	332161040R1
PCB5	C8168	CHIP ELECT C	CEWX4V-22M	1	3981G2207R2
PCB5	C8169	C-CERA C	CK725F1E-104Z1	1	332161040R1
PCB5	C8170	C-CERA C	CK725F1E-104Z1	1	332161040R1
PCB5	C8171	C-CERA C	CK725F1E-104Z1	1	332161040R1
PCB5	C8172	C-CERA C	CK725F1E-104Z1	1	332161040R1
PCB5	C8173	C-CERA C	CK725F1E-104Z1	1	332161040R1
PCB5	C8174	C-CERA C	CK725F1E-104Z1	1	332161040R1
PCB5	C8175	C-CERA C	CK725F1E-104Z1	1	332161040R1
PCB5	C8176	C-CERA C	CK725F1E-104Z1	1	332161040R1
PCB5	C8177	C-CERA C	CK725F1E-104Z1	1	332161040R1
PCB5	C8178	C-CERA C	CK725F1E-104Z1	1	332161040R1
PCB5	C8179	C-CERA C	CK725F1E-104Z1	1	332161040R1
PCB5	C8180	C-CERA C	CK725F1E-104Z1	1	332161040R1
PCB5	C8181	C-CERA C	CK725F1E-104Z1	1	332161040R1
PCB5	C8198	CD C	UCD1E221MNL1GS	1	396652217R2
PCB5	C8199	CD C	UCD1E221MNL1GS	1	396652217R2
PCB5	C8326	C-CERA C	CK725F1E-104Z1	1	332161040R1
PCB5	C8327	C-CERA C	CK725F1A-105Z1	1	332181050R1
PCB5	C8328	CHIP ELECT C	CEWX16V-22M	1	398142207R2
PCB5	C8329	C-CERA C	CK725F1A-105Z1	1	332181050R1
PCB5	C8330	C-CERA C	CK725F1A-105Z1	1	332181050R1

PCB5	C8331	C-CERA C	CK725F1E-104Z1	1	332161040R1
PCB5	C8348	C-CERA C	CK725B1H-102K1	1	332101025R1
PCB5	C8399	C-CERA C	CK725B1H-102K1	1	332101025R1
PCB5	C8401	CHIP ELECT C	CEWX4V-22M	1	3981G2207R2
PCB5	C8402	CHIP ELECT C	CEWX4V-22M	1	3981G2207R2
PCB5	C8403	C-CERA C	CK725F1A-105Z1	1	332181050R1
PCB5	C8404	C-CERA C	CK725B1H-102K1	1	332101025R1
PCB5	C8405	C-CERA C	CK725F1A-105Z1	1	332181050R1
PCB5	C8406	C-CERA C	CK725B1H-102K1	1	332101025R1
PCB5	C8407	C-CERA C	CC725CH1H-100D1	1	342101002R1
PCB5	C8408	CHIP ELECT C	CEWX4V-22M	1	3981G2207R2
PCB5	C8409	CHIP ELECT C	CEWX4V-22M	1	3981G2207R2
PCB5	C8410	C-CERA C	CK725F1A-105Z1	1	332181050R1
PCB5	C8411	C-CERA C	CK725B1H-102K1	1	332101025R1
PCB5	C8412	C-CERA C	CK725F1A-105Z1	1	332181050R1
PCB5	C8413	C-CERA C	CK725B1H-102K1	1	332101025R1
PCB5	C8414	C-CERA C	CK725F1A-105Z1	1	332181050R1
PCB5	C8415	C-CERA C	CK725B1H-102K1	1	332101025R1
PCB5	C8416	C-CERA C	CK725B1H-102K1	1	332101025R1
PCB5	C8417	C-CERA C	CK725F1A-105Z1	1	332181050R1
PCB5	C8418	CHIP ELECT C	CEWX4V-22M	1	3981G2207R2
PCB5	C8419	C-CERA C	CK725B1H-102K1	1	332101025R1
PCB5	C8420	C-CERA C	CK725F1A-105Z1	1	332181050R1
PCB5	C8421	C-CERA C	CK725B1H-102K1	1	332101025R1
PCB5	C8422	C-CERA C	CK725F1A-105Z1	1	332181050R1
PCB5	C8423	C-CERA C	CK725B1H-102K1	1	332101025R1
PCB5	C8424	C-CERA C	CK725F1A-105Z1	1	332181050R1
PCB5	C8425	C-CERA C	CK725B1H-102K1	1	332101025R1
PCB5	C8426	C-CERA C	CK725F1A-105Z1	1	332181050R1
PCB5	C8427	C-CERA C	CK725B1H-102K1	1	332101025R1
PCB5	C8428	C-CERA C	CK725F1A-105Z1	1	332181050R1
PCB5	C8429	C-CERA C	CK725B1H-102K1	1	332101025R1
PCB5	C8430	C-CERA C	CK725F1A-105Z1	1	332181050R1

PCB5	C8431	C-CERA C	CK725B1H-102K1	1	332101025R1
PCB5	C8432	C-CERA C	CK725F1A-105Z1	1	332181050R1
PCB5	C8433	C-CERA C	CK725B1H-102K1	1	332101025R1
PCB5	C8434	C-CERA C	CK725F1A-105Z1	1	332181050R1
PCB5	C8435	C-CERA C	CK725F1A-105Z1	1	332181050R1
PCB5	C8436	C-CERA C	CK725F1A-105Z1	1	332181050R1
PCB5	C8437	CHIP ELECT C	CEWX4V-22M	1	3981G2207R2
PCB5	C8438	C-CERA C	CK725B1H-102K1	1	332101025R1
PCB5	C8441	C-CERA C	CK725F1A-105Z1	1	332181050R1
PCB5	C8442	C-CERA C	CK725F1A-105Z1	1	332181050R1
PCB5	C8443	CHIP ELECT C	CEWX4V-220M	1	3981G2217R2
PCB5	C8444	C-CERA C	CK725F1A-105Z1	1	332181050R1
PCB5	C8501	C-CERA C	CK725F1A-105Z1	1	332181050R1
PCB5	C8502	CHIP ELECT C	CEWX4V-22M	1	3981G2207R2
PCB5	C8503	C-CERA C	CK725B1H-102K1	1	332101025R1
PCB5	C8504	C-CERA C	CK725B1H-102K1	1	332101025R1
PCB5	C8505	CHIP ELECT C	CEWX4V-22M	1	3981G2207R2
PCB5	C8506	C-CERA C	CK725F1A-105Z1	1	332181050R1
PCB5	C8507	C-CERA C	CK725B1H-102K1	1	332101025R1
PCB5	C8508	C-CERA C	CK725F1A-105Z1	1	332181050R1
PCB5	C8509	C-CERA C	CK725B1H-102K1	1	332101025R1
PCB5	C8510	C-CERA C	CK725F1A-105Z1	1	332181050R1
PCB5	C8511	C-CERA C	CK725B1H-102K1	1	332101025R1
PCB5	C8512	C-CERA C	CK725F1A-105Z1	1	332181050R1
PCB5	C8513	C-CERA C	CK725B1H-102K1	1	332101025R1
PCB5	C8514	C-CERA C	CK725F1A-105Z1	1	332181050R1
PCB5	C8515	C-CERA C	CK725B1H-102K1	1	332101025R1
PCB5	C8516	C-CERA C	CK725F1A-105Z1	1	332181050R1
PCB5	C8517	C-CERA C	CK725B1H-102K1	1	332101025R1
PCB5	C8518	C-CERA C	CK725F1A-105Z1	1	332181050R1
PCB5	C8519	C-CERA C	CK725B1H-102K1	1	332101025R1
PCB5	C8520	C-CERA C	CK725F1A-105Z1	1	332181050R1
PCB5	C8521	C-CERA C	CK725B1H-102K1	1	332101025R1

PCB5	C8522	C-CERA C	CK725F1A-105Z1	1	332181050R1
PCB5	C8523	C-CERA C	CK725B1H-102K1	1	332101025R1
PCB5	C8524	C-CERA C	CK725F1A-105Z1	1	332181050R1
PCB5	C8525	C-CERA C	CK725B1H-102K1	1	332101025R1
PCB5	C8529	CHIP ELECT C	CEWX4V-22M	1	3981G2207R2
PCB5	C8530	C-CERA C	CK725F1A-105Z1	1	332181050R1
PCB5	C8531	C-CERA C	CK725B1H-102K1	1	332101025R1
PCB5	C8532	C-CERA C	CK725F1A-105Z1	1	332181050R1
PCB5	C8533	C-CERA C	CK725B1H-102K1	1	332101025R1
PCB5	C8534	C-CERA C	CK725F1A-105Z1	1	332181050R1
PCB5	C8535	C-CERA C	CK725B1H-102K1	1	332101025R1
PCB5	C8536	C-CERA C	CK725F1A-105Z1	1	332181050R1
PCB5	C8537	C-CERA C	CK725B1H-102K1	1	332101025R1
PCB5	C8538	C-CERA C	CK725F1A-105Z1	1	332181050R1
PCB5	C8539	C-CERA C	CK725B1H-102K1	1	332101025R1
PCB5	C8540	C-CERA C	CK725F1A-105Z1	1	332181050R1
PCB5	C8541	C-CERA C	CK725B1H-102K1	1	332101025R1
PCB5	C8542	C-CERA C	CK725F1A-105Z1	1	332181050R1
PCB5	C8543	C-CERA C	CK725B1H-102K1	1	332101025R1
PCB5	C8544	C-CERA C	CK725F1A-105Z1	1	332181050R1
PCB5	C8545	C-CERA C	CK725B1H-102K1	1	332101025R1
PCB5	C8546	C-CERA C	CK725F1A-105Z1	1	332181050R1
PCB5	C8547	C-CERA C	CK725B1H-102K1	1	332101025R1
PCB5	C8548	C-CERA C	CK725F1A-105Z1	1	332181050R1
PCB5	C8549	C-CERA C	CK725B1H-102K1	1	332101025R1
PCB5	C8550	C-CERA C	CK725F1A-105Z1	1	332181050R1
PCB5	C8551	C-CERA C	CK725B1H-102K1	1	332101025R1
PCB5	C8552	C-CERA C	CK725F1A-105Z1	1	332181050R1
PCB5	C8553	C-CERA C	CK725B1H-102K1	1	332101025R1
PCB5	C8554	C-CERA C	CK725F1A-105Z1	1	332181050R1
PCB5	C8555	C-CERA C	CK725B1H-102K1	1	332101025R1
PCB5	C8556	C-CERA C	CK725F1A-105Z1	1	332181050R1
PCB5	C8557	C-CERA C	CK725B1H-102K1	1	332101025R1

PCB5	C8558	C-CERA C	CK725F1A-105Z1	1	332181050R1
PCB5	C8559	C-CERA C	CK725B1H-102K1	1	332101025R1
PCB5	C8560	C-CERA C	CK725F1A-105Z1	1	332181050R1
PCB5	C8561	C-CERA C	CK725B1H-102K1	1	332101025R1
PCB5	C8562	C-CERA C	CK725F1A-105Z1	1	332181050R1
PCB5	C8563	C-CERA C	CK725B1H-102K1	1	332101025R1
PCB5	C8564	CHIP ELECT C	CEWX4V-22M	1	3981G2207R2
PCB5	C8565	CHIP ELECT C	CEWX4V-22M	1	3981G2207R2
PCB5	C8566	C-CERA C	CK725B1H-102K1	1	332101025R1
PCB5	C8567	C-CERA C	CK725F1A-105Z1	1	332181050R1
PCB5	C8568	CHIP ELECT C	CEWX4V-22M	1	3981G2207R2
PCB5	C8569	C-CERA C	CK725B1H-102K1	1	332101025R1
PCB5	C8570	C-CERA C	CK725F1A-105Z1	1	332181050R1
PCB5	C8571	CHIP ELECT C	CEWX4V-22M	1	3981G2207R2
PCB5	C8572	C-CERA C	CK725B1H-102K1	1	332101025R1
PCB5	C8573	C-CERA C	CK725F1A-105Z1	1	332181050R1
PCB5	C8574	C-CERA C	CC725CH1H-070D1	1	342100702R1
PCB5	C8575	C-CERA C	CC725CH1H-070D1	1	342100702R1
PCB5	C8601	C-CERA C	CK725F1A-105Z1	1	332181050R1
PCB5	C8602	CHIP ELECT C	CEWX4V-100M	1	3981G1017R2
PCB5	C8603	C-CERA C	CK725F1A-105Z1	1	332181050R1
PCB5	C8604	C-CERA C	CK725F1A-105Z1	1	332181050R1
PCB5	C8605	CHIP ELECT C	CEWX4V-220M	1	3981G2217R2
PCB5	C8606	C-CERA C	CK725F1E-104Z1	1	332161040R1
PCB5	C8607	CHIP ELECT C	CEWX4V-100M	1	3981G1017R2
PCB5	C8608	C-CERA C	CK725F1A-105Z1	1	332181050R1
PCB5	C8609	CHIP ELECT C	CEWX4V-100M	1	3981G1017R2
PCB5	C8675	CHIP ELECT C	CEWX4V-100M	1	3981G1017R2
PCB5	C8676	C-CERA C	CK725F1A-105Z1	1	332181050R1
PCB5	C8680	CD C	UCD1A471MNL1GS	1	396634717R2
PCB5	C8682	C-CERA C	CK725B1H-223K1	1	332102235R1
PCB5	C8683	CD C	UCD1E221MNL1GS	1	396652217R2
PCB5	C8684	C-CERA C	CK725F1E-104Z1	1	332161040R1

PCB5	C8685	C-CERA C	CK725F1E-104Z1	1	332161040R1
PCB5	C8687	C-CERA C	CK725F1E-104Z1	1	332161040R1
PCB5	C8690	C-CERA C	CK725F1A-105Z1	1	332181050R1
PCB5	C8691	C-CERA C	CK725F1A-105Z1	1	332181050R1
PCB5	C8692	C-CERA C	CK725F1A-105Z1	1	332181050R1
PCB5	C8698	C-CERA C	CK725B1H-102K1	1	332101025R1
PCB5	C8699	C-CERA C	CK725B1H-102K1	1	332101025R1
PCB5	R10	C-CARBON R	RN72K1J-000JE	1	435030004R1
PCB5	R11	C-CARBON R	RN72K1J-000JE	1	435030004R1
PCB5	R12	C-CARBON R	RN72K1J-000JE	1	435030004R1
PCB5	R13	C-CARBON R	RN72K1J-000JE	1	435030004R1
PCB5	R200	C-CARBON R	RN72K1J-221JE	1	435032214R1
PCB5	R201	C-CARBON R	RN72K1J-103JE	1	435031034R1
PCB5	R202	C-CARBON R	RN72K1J-103JE	1	435031034R1
PCB5	R203	C-CARBON R	RN72K1J-103JE	1	435031034R1
PCB5	R205	C-CARBON R	RN72K1J-103JE	1	435031034R1
PCB5	R206	C-CARBON R	RN72K1J-221JE	1	435032214R1
PCB5	R207	C-CARBON R	RN72K1J-221JE	1	435032214R1
PCB5	R208	C-CARBON R	RN72K1J-103JE	1	435031034R1
PCB5	R209	C-CARBON R	RN72K1J-470JE	1	435034704R1
PCB5	R210	C-R NET	RM7LJ330X04	1	43484733004R2
PCB5	R211	C-R NET	RM7LJ330X04	1	43484733004R2
PCB5	R212	C-R NET	RM7LJ330X04	1	43484733004R2
PCB5	R213	C-R NET	RM7LJ330X04	1	43484733004R2
PCB5	R214	C-R NET	RM7LJ330X04	1	43484733004R2
PCB5	R215	C-R NET	RM7LJ330X04	1	43484733004R2
PCB5	R216	C-R NET	RM7LJ330X04	1	43484733004R2
PCB5	R217	C-R NET	RM7LJ330X04	1	43484733004R2
PCB5	R218	C-R NET	RM7LJ330X04	1	43484733004R2
PCB5	R221	C-CARBON R	RN72K1J-750JE	1	435037504R1
PCB5	R230	C-CARBON R	RN72K1J-331JE	1	435033314R1
PCB5	R231	C-CARBON R	RN72K1J-331JE	1	435033314R1
PCB5	R232	C-CARBON R	RN72K1J-331JE	1	435033314R1

PCB5	R233	C-CARBON R	RN72K1J-470JE	1	435034704R1
PCB5	R234	C-CARBON R	RN72K1J-331JE	1	435033314R1
PCB5	R235	C-CARBON R	RN72K1J-331JE	1	435033314R1
PCB5	R236	C-CARBON R	RN72K1J-470JE	1	435034704R1
PCB5	R237	C-CARBON R	RN72K1J-331JE	1	435033314R1
PCB5	R238	C-CARBON R	RN72K1J-221JE	1	435032214R1
PCB5	R239	C-CARBON R	RN72K1J-470JE	1	435034704R1
PCB5	R240	C-CARBON R	RN72K1J-331JE	1	435033314R1
PCB5	R241	C-CARBON R	RN72K1J-331JE	1	435033314R1
PCB5	R242	C-CARBON R	RN72K1J-470JE	1	435034704R1
PCB5	R243	C-CARBON R	RN72K1J-221JE	1	435032214R1
PCB5	R244	C-CARBON R	RN72K1J-470JE	1	435034704R1
PCB5	R245	C-CARBON R	RN72K1J-103JE	1	435031034R1
PCB5	R250	C-CARBON R	RN72K1J-472JE	1	435034724R1
PCB5	R251	C-CARBON R	RN72K1J-221JE	1	435032214R1
PCB5	R252	C-CARBON R	RN72K1J-331JE	1	435033314R1
PCB5	R253	C-CARBON R	RN72K1J-470JE	1	435034704R1
PCB5	R254	C-CARBON R	RN72K1J-470JE	1	435034704R1
PCB5	R255	C-CARBON R	RN72K1J-470JE	1	435034704R1
PCB5	R256	C-CARBON R	RN72K1J-470JE	1	435034704R1
PCB5	R257	C-CARBON R	RN72K1J-470JE	1	435034704R1
PCB5	R258	C-CARBON R	RN72K1J-470JE	1	435034704R1
PCB5	R259	C-CARBON R	RN72K1J-331JE	1	435033314R1
PCB5	R260	C-CARBON R	RN72K1J-470JE	1	435034704R1
PCB5	R261	C-CARBON R	RN72K1J-470JE	1	435034704R1
PCB5	R262	C-CARBON R	RN72K1J-331JE	1	435033314R1
PCB5	R263	C-CARBON R	RN72K1J-331JE	1	435033314R1
PCB5	R264	C-CARBON R	RN72K1J-331JE	1	435033314R1
PCB5	R265	C-CARBON R	RN72K1J-331JE	1	435033314R1
PCB5	R266	C-CARBON R	RN72K1J-221JE	1	435032214R1
PCB5	R267	C-CARBON R	RN72K1J-331JE	1	435033314R1
PCB5	R268	C-CARBON R	RN72K1J-331JE	1	435033314R1
PCB5	R269	C-CARBON R	RN72K1J-331JE	1	435033314R1

PCB5	R270	C-CARBON R	RN72K1J-221JE	1	435032214R1
PCB5	R271	C-CARBON R	RN72K1J-105JE	1	435031054R1
PCB5	R272	C-CARBON R	RN72K1J-151JE	1	435031514R1
PCB5	R273	C-CARBON R	RN72K1J-470JE	1	435034704R1
PCB5	R274	C-CARBON R	RN72K1J-470JE	1	435034704R1
PCB5	R275	C-CARBON R	RN72K1J-470JE	1	435034704R1
PCB5	R279	C-CARBON R	RN72K1J-470JE	1	435034704R1
PCB5	R281	C-CARBON R	RN72K1J-103JE	1	435031034R1
PCB5	R282	C-CARBON R	RN72K1J-103JE	1	435031034R1
PCB5	R283	C-CARBON R	RN72K1J-103JE	1	435031034R1
PCB5	R284	C-CARBON R	RN72K1J-103JE	1	435031034R1
PCB5	R285	C-CARBON R	RN72K1J-103JE	1	435031034R1
PCB5	R286	C-CARBON R	RN72K1J-331JE	1	435033314R1
PCB5	R287	C-CARBON R	RN72K1J-103JE	1	435031034R1
PCB5	R288	C-CARBON R	RN72K1J-103JE	1	435031034R1
PCB5	R289	C-CARBON R	RN72K1J-472JE	1	435034724R1
PCB5	R290	C-CARBON R	RN72K1J-472JE	1	435034724R1
PCB5	R291	C-CARBON R	RN72K1J-332JE	1	435033324R1
PCB5	R292	C-CARBON R	RN72K1J-333JE	1	435033334R1
PCB5	R293	C-CARBON R	RN72K1J-152JE	1	435031524R1
PCB5	R294	C-CARBON R	RN72K1J-152JE	1	435031524R1
PCB5	R295	C-CARBON R	RN72K1J-333JE	1	435033334R1
PCB5	R296	C-CARBON R	RN72K1J-393JE	1	435033934R1
PCB5	R297	C-CARBON R	RN72K1J-393JE	1	435033934R1
PCB5	R8001	C-R NET	RM7LJ103X04	1	43484710304R2
PCB5	R8002	C-CARBON R	RN72K1J-103JE	1	435031034R1
PCB5	R8003	C-CARBON R	RN72K1J-221JE	1	435032214R1
PCB5	R8004	C-CARBON R	RN72K1J-103JE	1	435031034R1
PCB5	R8005	C-CARBON R	RN72K1J-103JE	1	435031034R1
PCB5	R8006	C-CARBON R	RN72K1J-470JE	1	435034704R1
PCB5	R8007	C-CARBON R	RN72K1J-470JE	1	435034704R1
PCB5	R8008	C-CARBON R	RN72K1J-470JE	1	435034704R1
PCB5	R8009	C-CARBON R	RN72K1J-103JE	1	435031034R1

PCB5	R8010	C-CARBON R	RN72K1J-470JE	1	435034704R1
PCB5	R8011	C-CARBON R	RN72K1J-470JE	1	435034704R1
PCB5	R8012	C-CARBON R	RN72K1J-470JE	1	435034704R1
PCB5	R8013	C-CARBON R	RN72K1J-470JE	1	435034704R1
PCB5	R8014	C-CARBON R	RN72K1J-470JE	1	435034704R1
PCB5	R8015	C-CARBON R	RN72K1J-470JE	1	435034704R1
PCB5	R8016	C-R NET	RM7LJ220X04	1	43484722004R2
PCB5	R8017	C-R NET	RM7LJ220X04	1	43484722004R2
PCB5	R8018	C-R NET	RM7LJ220X04	1	43484722004R2
PCB5	R8019	C-R NET	RM7LJ220X04	1	43484722004R2
PCB5	R8020	C-R NET	RM7LJ220X04	1	43484722004R2
PCB5	R8021	C-R NET	RM7LJ220X04	1	43484722004R2
PCB5	R8022	C-R NET	RM7LJ220X04	1	43484722004R2
PCB5	R8023	C-R NET	RM7LJ220X04	1	43484722004R2
PCB5	R8029	C-CARBON R	RN72K1J-103JE	1	435031034R1
PCB5	R8030	C-CARBON R	RN72K1J-103JE	1	435031034R1
PCB5	R8031	C-CARBON R	RN72K1J-103JE	1	435031034R1
PCB5	R8032	C-CARBON R	RN72K1J-103JE	1	435031034R1
PCB5	R8039	C-CARBON R	RN72K1J-560JE	1	435035604R1
PCB5	R8041	C-CARBON R	RN72K1J-103JE	1	435031034R1
PCB5	R8042	C-CARBON R	RN72K1J-220JE	1	435032204R1
PCB5	R8043	C-CARBON R	RN72K1J-750JE	1	435037504R1
PCB5	R8044	C-CARBON R	RN72K1J-220JE	1	435032204R1
PCB5	R8045	C-CARBON R	RN72K1J-680JE	1	435036804R1
PCB5	R8046	C-CARBON R	RN72K1J-220JE	1	435032204R1
PCB5	R8047	C-CARBON R	RN72K1J-750JE	1	435037504R1
PCB5	R8048	C-CARBON R	RN72K1J-680JE	1	435036804R1
PCB5	R8049	C-CARBON R	RN72K1J-471JE	1	435034714R1
PCB5	R8050	C-CARBON R	RN72K1J-103JE	1	435031034R1
PCB5	R8051	C-CARBON R	RN72K1J-220JE	1	435032204R1
PCB5	R8052	C-CARBON R	RN72K1J-750JE	1	435037504R1
PCB5	R8053	C-CARBON R	RN72K1J-220JE	1	435032204R1
PCB5	R8054	C-CARBON R	RN72K1J-750JE	1	435037504R1

PCB5	R8055	C-CARBON R	RN72K1J-220JE	1	435032204R1
PCB5	R8056	C-CARBON R	RN72K1J-750JE	1	435037504R1
PCB5	R8057	C-CARBON R	RN72K1J-680JE	1	435036804R1
PCB5	R8058	C-CARBON R	RN72K1J-471JE	1	435034714R1
PCB5	R8059	C-R NET	RM7LJ103X04	1	43484710304R2
PCB5	R8060	C-CARBON R	RN72K1J-680JE	1	435036804R1
PCB5	R8061	C-CARBON R	RN72K1J-471JE	1	435034714R1
PCB5	R8062	C-R NET	RM7LJ103X04	1	43484710304R2
PCB5	R8063	C-CARBON R	RN72K1J-680JE	1	435036804R1
PCB5	R8064	C-CARBON R	RN72K1J-471JE	1	435034714R1
PCB5	R8065	C-CARBON R	RN72K1J-222JE	1	435032224R1
PCB5	R8066	C-CARBON R	RN72K1J-222JE	1	435032224R1
PCB5	R8068	C-CARBON R	RN72K1J-103JE	1	435031034R1
PCB5	R8070	C-CARBON R	RN72K1J-272JE	1	435032724R1
PCB5	R8071	C-CARBON R	RN72K1J-272JE	1	435032724R1
PCB5	R8075	C-CARBON R	RN72K1J-750JE	1	435037504R1
PCB5	R8076	C-CARBON R	RN72K1J-750JE	1	435037504R1
PCB5	R8077	C-CARBON R	RN72K1J-750JE	1	435037504R1
PCB5	R8080	C-CARBON R	RN72K1J-272JE	1	435032724R1
PCB5	R8081	C-CARBON R	RN72K1J-272JE	1	435032724R1
PCB5	R8085	C-CARBON R	RN72K1J-103JE	1	435031034R1
PCB5	R8087	C-CARBON R	RN72K1J-103JE	1	435031034R1
PCB5	R8090	C-CARBON R	RN72K1J-680JE	1	435036804R1
PCB5	R8091	C-CARBON R	RN72K1J-222JE	1	435032224R1
PCB5	R8092	C-CARBON R	RN72K1J-333JE	1	435033334R1
PCB5	R8108	C-CARBON R	RN72K1J-470JE	1	435034704R1
PCB5	R8109	C-CARBON R	RN72K1J-473JE	1	435034734R1
PCB5	R8110	C-CARBON R	RN72K1J-472JE	1	435034724R1
PCB5	R8113	C-CARBON R	RN72K1J-103JE	1	435031034R1
PCB5	R8114	C-CARBON R	RN72K1J-000JE	1	435030004R1
PCB5	R8115	C-CARBON R	RN72K1J-000JE	1	435030004R1
PCB5	R8123	C-CARBON R	RN72K1J-103JE	1	435031034R1
PCB5	R8129	C-CARBON R	RN72K1J-473JE	1	435034734R1

PCB5	R8130	C-CARBON R	RN72K1J-472JE	1	435034724R1
PCB5	R8143	C-CARBON R	RN72K1J-103JE	1	435031034R1
PCB5	R8149	C-CARBON R	RN72K1J-473JE	1	435034734R1
PCB5	R8150	C-CARBON R	RN72K1J-472JE	1	435034724R1
PCB5	R8160	C-CARBON R	RN72K1J-103JE	1	435031034R1
PCB5	R8161	C-CARBON R	RN72K1J-681JE	1	435036814R1
PCB5	R8162	C-CARBON R	RN72K1J-101JE	1	435031014R1
PCB5	R8163	C-CARBON R	RN72K1J-222JE	1	435032224R1
PCB5	R8164	C-CARBON R	RN72K1J-222JE	1	435032224R1
PCB5	R8165	C-CARBON R	RN72K1J-103JE	1	435031034R1
PCB5	R8332	C-CARBON R	RN72K1J-102JE	1	435031024R1
PCB5	R8333	C-CARBON R	RN72K1J-103JE	1	435031034R1
PCB5	R8334	C-CARBON R	RN72K1J-182JE	1	435031824R1
PCB5	R8335	C-CARBON R	RN72K1J-182JE	1	435031824R1
PCB5	R8336	C-CARBON R	RN72K1J-472JE	1	435034724R1
PCB5	R8337	C-CARBON R	RN72K1J-473JE	1	435034734R1
PCB5	R8338	C-CARBON R	RN72K1J-473JE	1	435034734R1
PCB5	R8339	C-CARBON R	RN72K2E-470JE	1	435224704R1
PCB5	R8401	C-R NET	RM7LJ220X04	1	43484722004R2
PCB5	R8402	C-CARBON R	RN72K1J-221JE	1	435032214R1
PCB5	R8403	C-R NET	RM7LJ220X04	1	43484722004R2
PCB5	R8404	C-CARBON R	RN72K1J-220JE	1	435032204R1
PCB5	R8405	C-CARBON R	RN72K1J-220JE	1	435032204R1
PCB5	R8408	C-CARBON R	RN72K1J-220JE	1	435032204R1
PCB5	R8409	C-CARBON R	RN72K1J-101JE	1	435031014R1
PCB5	R8410	C-CARBON R	RN72K1J-681JE	1	435036814R1
PCB5	R8411	C-CARBON R	RN72K1J-472JE	1	435034724R1
PCB5	R8414	C-CARBON R	RN72K1J-472JE	1	435034724R1
PCB5	R8415	C-CARBON R	RN72K1J-472JE	1	435034724R1
PCB5	R8416	C-R NET	RM7LJ220X04	1	43484722004R2
PCB5	R8417	C-R NET	RM7LJ220X04	1	43484722004R2
PCB5	R8418	C-R NET	RM7LJ220X04	1	43484722004R2
PCB5	R8419	C-R NET	RM7LJ220X04	1	43484722004R2

PCB5	R8420	C-R NET	RM7LJ220X04	1	43484722004R2
PCB5	R8421	C-R NET	RM7LJ220X04	1	43484722004R2
PCB5	R8422	C-R NET	RM7LJ220X04	1	43484722004R2
PCB5	R8423	C-R NET	RM7LJ220X04	1	43484722004R2
PCB5	R8424	C-R NET	RM7LJ220X04	1	43484722004R2
PCB5	R8425	C-CARBON R	RN72K1J-220JE	1	435032204R1
PCB5	R8426	C-CARBON R	RN72K1J-473JE	1	435034734R1
PCB5	R8427	C-CARBON R	RN72K1J-473JE	1	435034734R1
PCB5	R8429	C-CARBON R	RN72K1J-220JE	1	435032204R1
PCB5	R8431	C-CARBON R	RN72K1J-472JE	1	435034724R1
PCB5	R8432	C-CARBON R	RN72K1J-220JE	1	435032204R1
PCB5	R8442	C-CARBON R	RN72K1J-102JE	1	435031024R1
PCB5	R8465	C-CARBON R	RN72K1J-102JE	1	435031024R1
PCB5	R8501	C-CARBON R	RN72K1J-330JE	1	435033304R1
PCB5	R8502	C-CARBON R	RN72K1J-330JE	1	435033304R1
PCB5	R8503	C-CARBON R	RN72K1J-330JE	1	435033304R1
PCB5	R8504	C-R NET	RM7LJ330X04	1	43484733004R2
PCB5	R8505	C-R NET	RM7LJ330X04	1	43484733004R2
PCB5	R8506	C-CARBON R	RN72K1J-120JE	1	435031204R1
PCB5	R8507	C-R NET	RM7LJ330X04	1	43484733004R2
PCB5	R8508	C-R NET	RM7LJ330X04	1	43484733004R2
PCB5	R8509	C-R NET	RM7LJ330X04	1	43484733004R2
PCB5	R8510	C-R NET	RM7LJ330X04	1	43484733004R2
PCB5	R8511	C-R NET	RM7LJ330X04	1	43484733004R2
PCB5	R8512	C-R NET	RM7LJ330X04	1	43484733004R2
PCB5	R8513	C-R NET	RM7LJ330X04	1	43484733004R2
PCB5	R8514	C-CARBON R	RN72K1J-472JE	1	435034724R1
PCB5	R8516	C-CARBON R	RN72K1J-101JE	1	435031014R1
PCB5	R8517	C-CARBON R	RN72K1J-101JE	1	435031014R1
PCB5	R8518	C-CARBON R	RN72K1J-472JE	1	435034724R1
PCB5	R8519	C-CARBON R	RN72K1J-151JE	1	435031514R1
PCB5	R8520	C-CARBON R	RN72K1J-330JE	1	435033304R1
PCB5	R8521	C-CARBON R	RN72K1J-330JE	1	435033304R1

PCB5	R8522	C-R NET	RM7LJ330X04	1	43484733004R2
PCB5	R8523	C-CARBON R	RN72K1J-330JE	1	435033304R1
PCB5	R8524	C-CARBON R	RN72K1J-330JE	1	435033304R1
PCB5	R8591	C-CARBON R	RN72K1J-332JE	1	435033324R1
PCB5	R8592	C-CARBON R	RN72K1J-333JE	1	435033334R1
PCB5	R8593	C-CARBON R	RN72K1J-152JE	1	435031524R1
PCB5	R8594	C-CARBON R	RN72K1J-152JE	1	435031524R1
PCB5	R8595	C-CARBON R	RN72K1J-101JE	1	435031014R1
PCB5	R8597	C-CARBON R	RN72K1J-101JE	1	435031014R1
PCB5	R8629	C-CARBON R	RN72K1J-562JE	1	435035624R1
PCB5	R8630	C-CARBON R	RN72K1J-562JE	1	435035624R1
PCB5	R8633	C-CARBON R	RN72K1J-102JE	1	435031024R1
PCB5	R8634	C-CARBON R	RN72K1J-103JE	1	435031034R1
PCB5	R8637	C-CARBON R	RN72K1J-102JE	1	435031024R1
PCB5	R8638	C-CARBON R	RN72K1J-473JE	1	435034734R1
PCB5	R8639	C-CARBON R	RN72K1J-473JE	1	435034734R1
PCB5	R8642	C-CARBON R	RN72K1J-562JE	1	435035624R1
PCB5	R8643	C-CARBON R	RN72K1J-562JE	1	435035624R1
PCB5	R8648	C-CARBON R	RN72K1J-473JE	1	435034734R1
PCB5	R8650	C-CARBON R	RN72K1J-473JE	1	435034734R1
PCB5	R8662	C-CARBON R	RN72K1J-105JE	1	435031054R1
PCB5	R8931	C-CARBON R	RN72K1J-333JE	1	435033334R1
PCB5	R8932	C-CARBON R	RN72K1J-152JE	1	435031524R1
PCB5	R8933	C-CARBON R	RN72K1J-152JE	1	435031524R1
PCB5	R8934	C-CARBON R	RN72K1J-332JE	1	435033324R1
PCB5	P2801B	SOCKET	NSCT-13P2143	1	25052246
PCB5	P8001B	SOCKET	IMSA-9111S-16L	1	25053258
PCB5	P8002B	SOCKET	IMSA-9111S-16L	1	25053258
PCB5	P8003B	SOCKET	IMSA-9111S-16L	1	25053258
PCB5	P8011	SOCKET	NSCT-4P2238	1	25052341
PCB5	P8101	SOCKET	YKF45-7037V	1	25053253R3
PCB5	P8121	SOCKET	YKF45-7037V	1	25053253R3
PCB5	P8141	SOCKET	YKF45-7037V	1	25053253R3

PCB5	P8302	SOCKET	YKF45-7037V	1	25053253R3
PCB5	P8601	SOCKET	YKF45-7037V	1	25053253R3
PCB5	JL8001B	WIRE TRAP	NPLG-5P588	1	25055626

ONKYO CORPORATION

Sales & Product Planning Div. : 2-1, Nisshin-cho, Neyagawa-shi, OSAKA 572-8540, JAPAN
Tel: 072-831-8023 Fax: 072-831-8163

ONKYO U.S.A. CORPORATION

18 Park Way, Upper Saddle River, N.J. 07458, U.S.A.
Tel: 201-785-2600 Fax: 201-785-2650 <http://www.us.onkyo.com/>

ONKYO EUROPE ELECTRONICS GmbH

Liegnitzerstrasse 6, 82194 Groebenzell, GERMANY
Tel: +49-8142-4401-0 Fax: +49-8142-4401-555 <http://www.eu.onkyo.com/>

ONKYO EUROPE UK Office

Suite 1, Gregories Court, Gregories Road, Beaconsfield, Buckinghamshire, HP9 1HQ
UNITED KINGDOM Tel: +44-(0)1494-681515 Fax: +44(0)-1494-680452

ONKYO CHINA LIMITED

Units 2102-2107, Metroplaza Tower I, 223 Hing Fong Road, Kwai Chung,
N.T., HONG KONG Tel: 852-2429-3118 Fax: 852-2428-9039
<http://www.ch.onkyo.com/>

