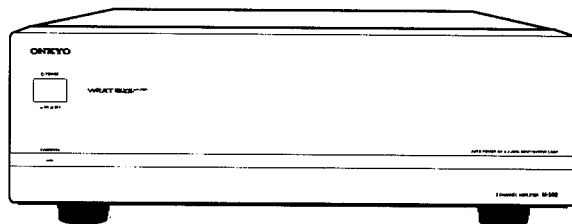

**ONKYO® SERVICE MANUAL****2 CHANNEL  
AMPLIFIER  
MODEL M-282****Black model**

BMDD	120 V AC, 60 Hz
------	-----------------

**SAFETY-RELATED COMPONENT WARNING!!**

COMPONENTS IDENTIFIED BY MARK  $\triangle$  ON THE SCHEMATIC DIAGRAM AND IN THE PARTS LIST ARE CRITICAL FOR RISK OF FIRE AND ELECTRIC SHOCK. REPLACE THESE COMPONENTS WITH ONKYO PARTS WHOSE PARTS NUMBERS APPEAR AS SHOWN IN THIS MANUAL.

MAKE LEAKAGE-CURRENT OR RESISTANCE MEASUREMENTS TO DETERMINE THAT EXPOSED PARTS ARE ACCEPTABLY INSULATED FROM THE SUPPLY CIRCUIT BEFORE RETURNING THE APPLIANCE TO THE CUSTOMER.

**TABLE OF CONTENTS**

Specifications .....	2
Service procedures .....	2
Adjustment and confirmation procedures.....	3
Panel view .....	4
Parts list .....	6
Exploded view .....	7
PC board view .....	9
Schematic diagram .....	11
PC board-parts list .....	13
IC block diagram .....	14
Block diagram .....	15
Packing view .....	16



# SPECIFICATIONS

## AMPLIFIER SECTION

Power Output:	100 Watts per channel min. RMS at 8 ohms, both channel driven from 20 to 20,000 Hz with no more than 0.08 % total harmonic distortion.
	125 Watts per channel min. RMS at 6 ohms, both channel driven from 1 kHz with no more than 0.1 % total harmonic distortion.
Dynamic Power Output:	2 × 140 Watts at 8 ohms
Total Harmonic Distortion:	0.08 % at rated power
IM Distortion:	0.08 % at rated power
Damping Factor:	100 at 8 ohms
Input Sensitivity and Impedance:	1 V, 50 kohms
Output Level and Impedance:	1 V, 10 kohms
Rated Speaker Impedance:	6 ohms MIN
Frequency Response:	10 Hz ~ 100 kHz, ±1 dB
Signal-to-Noise Ratio:	110 dB (IHF A, 0.5 V input)

## GENERAL

Power Supply:	AC 120 V, 60 Hz
Power Consumption:	2.5 A
Dimensions (W × H × D):	435 × 145 × 316 mm 17-1/8" × 5-1/16" × 12-7/16"
Weight:	8.5 kg, 18.7 lbs.

Specifications and features are subject to change without notice.

# SERVICE PROCEDURES

## 1. Replacing the fuses

 This symbol located near the fuses indicates that the fuse used is slow operating type. For continued protection against fire hazard, replace with same type fuse. For fuse rating refer to the marking adjacent to the symbol.

 Ce symbole indique que le fusible utilise est a lene. Pour une protection permanente, n'utiliser que fusibles de meme type. Ce dernier est la qu le present symbol est appse.

CIRCUIT NO.	PART NO.	DESCRIPTION
F901	252164 	5A-UL/T-237, Primary

## 2. Safety-check out

After correcting the original service problem perform the following safety check before releasing the set to the customer. Connect the insulating-resistance tester between the plug of power supply cord and screw on the back panel.

Specifications: More than 50 MΩ at 500 V

# ADJUSTMENT AND CONFIRMATION PROCEDURES

## Idling current adjustment

Before Idling adjustment, turn the trimming resistors R533 and R534 to counter clockwise. Connect the DC voltmeter to sockets P511 and P512.

After turn POWER to ON, adjust the trimming resistors R533 and R534 so that the reading of voltmeter becomes  $2.0 \pm 0.1$  mV.

After adjustment, attach the top cover. After about 5 minutes of heat running, readjust R533 and R534 according to the following procedures.

2.5 mV to 4.5 mV: Adjust to 4.5 mV to 5.0 mV.

4.5 mV to 5.5 mV: Keep that value.

5.5 mV to 9mV: Adjust to 5.0mV to 5.5mV.

Note: No load and No signal

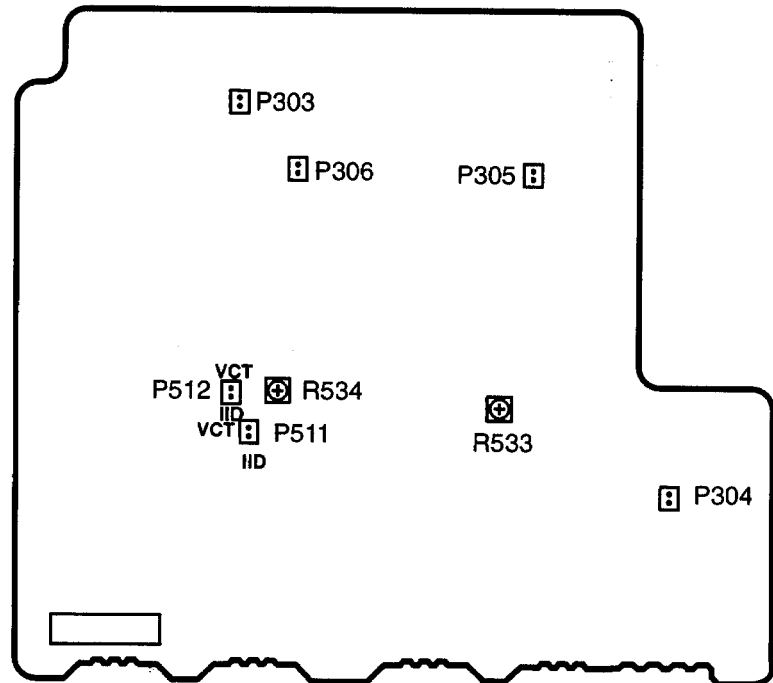

## Confirmation of protection circuit

### 1. Confirmation of DC detection circuit

Apply DC 3 V to INPUT terminals with no load.

Confirm that the speaker relay turns OFF immediately and the secondary relay turns OFF after 2 seconds.

Apply DC -3V to INPUT terminals with no load.

Confirm that the speaker relay turns OFF immediately and the secondary relay turns OFF after 2 seconds.

### 2. Confirmation of Current detection circuit

Connect Differential circuit and apply the 50 Hz square signal to the INPU terminal.

Adjust the attenuator or Volume so that the output level becomes 35 V p-p.

Confirm that the speaker relay turns OFF when a 2 ohm load is connected.

Confirm that the speaker relay turns OFF immediately and secondary relay turns off after 2 seconds when a 0.5 ohm load is connected to the speaker terminal of left or right channel.

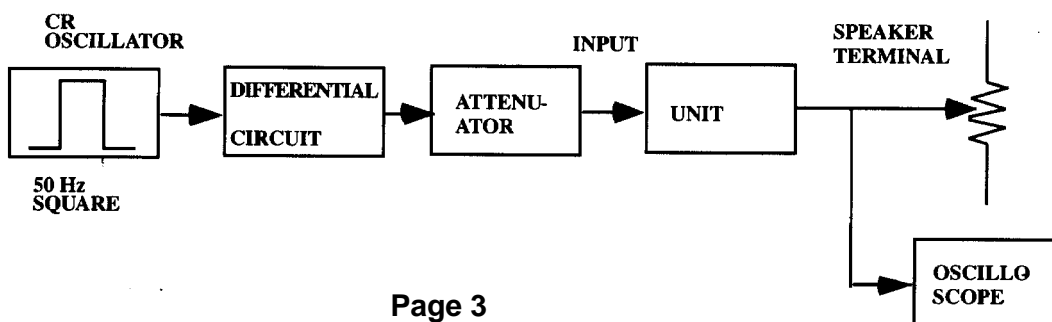

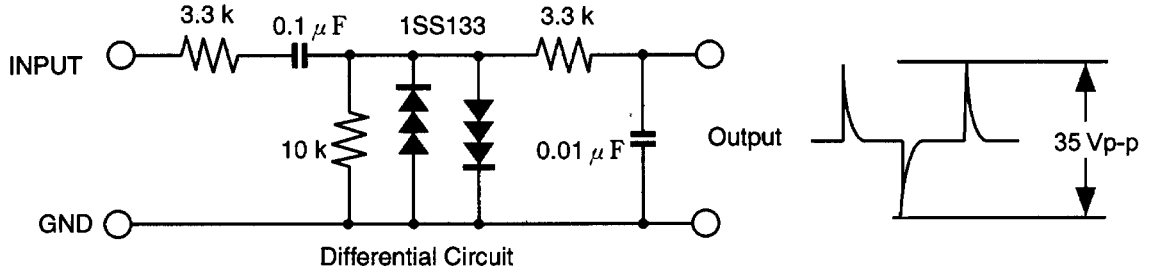

### Confirmation of trigger switch

Trigger switch: Audio	LED	Secondary relay	Muting transistor	Speaker relay
Turn POWER switch to ON.	Flashing red.	On	On	Off
After 5 seconds.	1. Light red when signal is not applied to the input terminal. Light orange when signal is applied.  2. Light orange when signal is applied to the input terminal. Light red when signal is not applied more than 4 minutes.		1. Off when signal is not applied to the input terminal. On when signal is applied.  2. On when signal is applied to the input terminal.	On
Trigger switch: Off	Flashing red.	On	On	Off
Turn POWER switch to ON.	Light orange		Off	On
After 5 seconds.				
Trigger switch: 12V	Flashing red.	Off	On	Off
Turn POWER switch to ON.	1. Light red when signal is not applied to the trigger input terminal. Light orange when signal is applied.	Off	On	Off
After 5 seconds.	2. Light orange when signal is applied to the trigger input terminal.	On	Off	On
		On	Off	On

## PANEL VIEWS

### Front Panel

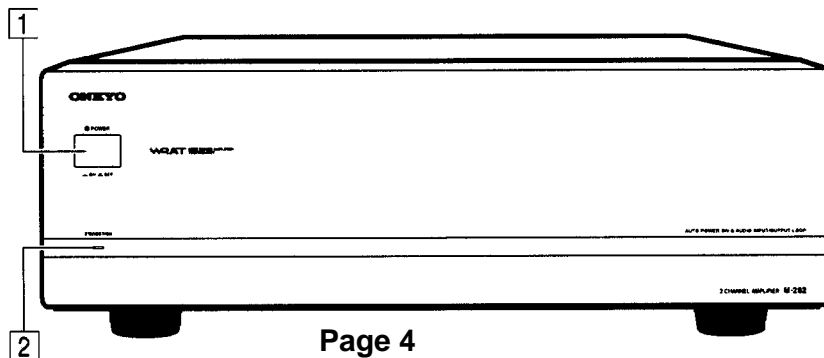

## 1 POWER

After plugging in the power cord into the rear panel and wall outlet, pressing this switch connects the M-282 to the AC mains. The function of this switch differs depending on the setting of the TRIGGER switch on the rear panel. Before turning on the power, be sure to set the TRIGGER switch. Besides, before turning on the power, make sure all cables are properly connected.

The TRIGGER switch is factory set to OFF.

### When the TRIGGER switch is set to OFF

Pressing the POWER switch turns on the M-282. The STANDBY/ON indicator lights orange after flashing red for 5 seconds.

Press the POWER switch again to turn off the M-282.

### When the TRIGGER switch is set to 12V TRIGGER

If no signal is supplied to the 12V TRIGGER IN jack, pressing the POWER switch enters the standby state and the STANDBY/ON indicator lights red.

If 12V DC is supplied to the 12V TRIGGER IN jack, pressing the POWER switch turns on the M-282 and the STANDBY/ON indicator lights orange after flashing red for 5 seconds.

If the M-282 is in the standby state, the M-282 turns on automatically when 12V DC is supplied to the 12V TRIGGER IN jack.

When the signal input to the 12V TRIGGER IN jack is interrupted, the indicator lights red and the M-282 enters standby state (Auto Power On/Off Function).

Press the POWER switch to turn off the M-282.

### When the TRIGGER switch is set to AUDIO

If no signal is supplied to the AUDIO IN jacks, pressing the POWER switch enters the standby state and the STANDBY/ON indicator lights red after flashing red for 5 seconds.

If an audio signal is supplied to the AUDIO IN jacks, pressing the POWER switch turns on the M-282 and the STANDBY/ON indicator lights orange after flashing red for 5 seconds.

If the M-282 is in the standby state, the M-282 turns on automatically when an audio signal is supplied to the AUDIO IN jacks.

When the signal input to the AUDIO IN jacks is not supplied for more than 4 minutes, the indicator turns to red and the M-282 enters standby state (Auto Power On/Off Function).

Press the POWER switch to turn off the M-282.

### Note:

You cannot use the Auto Power On Function when the power is turned off. To use the Auto Power On Function, leave the M-282 in the standby state once the M-282 enters the standby state.

## 2 STANDBY/ON indicator

The STANDBY/ON indicator lights red when the M-282 is in the standby state and lights orange when the M-282 is turned on.

## Rear Panel

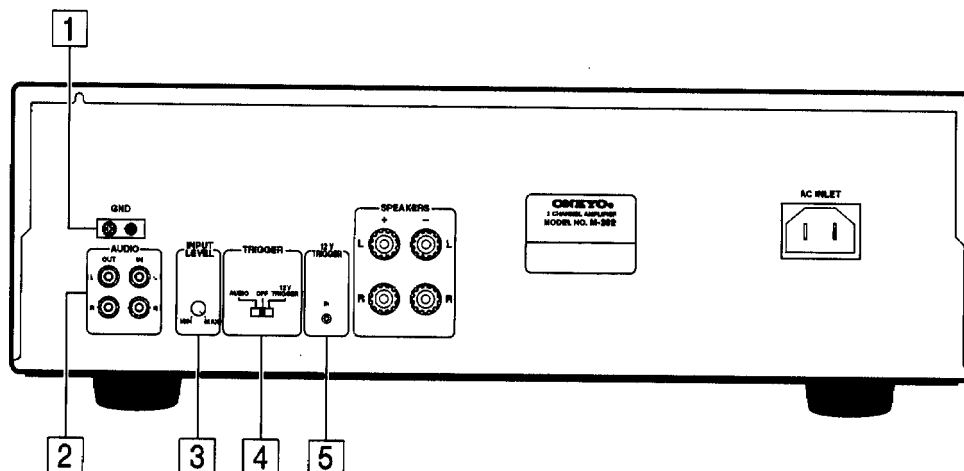

### 1 GND

Use this GND terminal for connecting the ground (or earth) wire of other component if humming noise is heard.

### 2 AUDIO IN/OUT

These are the analog audio inputs and outputs. Use an RCA-type audio connection cable to connect the output jacks of the device to the AUDIO IN jacks on the M-282. When connecting a control amplifier or preamplifier, connect the PRE OUT jacks to the AUDIO IN jacks.

If you connect the AUDIO OUT jacks of the M-282 to the AUDIO IN jacks of another M-282, the signal input at the AUDIO IN jacks of the M-282 is also output from the AUDIO OUT jacks (Audio In/Out Link Function).

If you set the TRIGGER switch to AUDIO, the power of the connected M-282 turns on automatically when an audio signal is supplied to the AUDIO IN jacks (Auto Power On/Off Function).

### 3 INPUT LEVEL

Turn this INPUT LEVEL control to adjust the input level of the signal from the AUDIO IN jacks. Normally, set to MAX.

### Note:

When a CD player is connected to the M-282, be sure to adjust the INPUT LEVEL control.

### 4 TRIGGER

Set this TRIGGER switch before turning on the M-282.

To turn on the M-282 with the signal input from the 12V TRIGGER IN jack, set the TRIGGER switch to 12V TRIGGER. To turn on the M-282 with the signal input from the AUDIO IN jack, set the TRIGGER switch to AUDIO (Auto Power On/Off Function). If you do not use Auto Power Function, set the TRIGGER switch to OFF.

### 5 12V TRIGGER IN

If the connected control amplifiers or preamplifiers have a 12V TRIGGER output jack, use 1/8-inch 2P mini-jack cable to connect the 12V TRIGGER IN jack on the M-282. This jack works on between 5 to 12 volts DC. When the M-282 is in the standby state and the TRIGGER switch is set to 12V TRIGGER, you can switch the M-282 between the on and standby states with operations at the control amplifier or preamplifier.

### Note:

When a plug is connected to the 12V TRIGGER jack, be sure to connect the analog output jacks (or PRE OUT jacks) of the device to the AUDIO IN jacks of the M-282. Otherwise, no sound will be produced.

## PARTS LIST

REF. NO.	PART NO.	DESCRIPTION
1	27111191	Front bracket
2	838430107	3TTB+10S(BC), self-tapping screw
3	27100321B	Chassis
4	27190511	KGLS-16RF,Holder
5	27190991	Holder
6	830440089	4TTC+8C(BC), Self-tapping screw
7	27160379	Heat sink
8	801433	3SMS8W.SW+14B(BC),Special screw
9	27141530A	Retainer HS
10	27141671	Retainer
11	838130088	3TTB+8B, Self-tapping screw
12	28198902	Facet
13	28325465	Knob, power
14	28199223	Film
15	27212262	Front panel
16	838430088	3TTB+8B(BC), Self-tapping screw
17	27122785	Rear panel
18	838440089	4TTB+8C(BC), Self-tapping screw
19	87643010	W3*10F(BC), Flat washer
20	838930088	3TTB+8B(UN), Self-tapping screw
21	28184663	Top cover
22	27175321A	Leg
23	28141332	Cushion
24	838430167	3TTB+16S(BC),Self-tapping screw
25	223025	AC262,Isolated sheet
26	260208	Wire tie
D911	22380038 or	RBV602 or
	22380274	RS603M,Diode
F901	252164	△ 5A-UL/T-237, Fuse
Q521,Q522	2202823 or	* 2SC5200-O or
	2202822	* 2SC5200-R,Transistor
Q523,Q524	2202813 or	* 2SA1943-O or
	2202812	* 2SA1943-R,Transistor
T901	2301216	△ NPT-1281D,Power transformer
U1	1A893523-1A	NAAF-7023-1A, Main circuit PC board ass'y
U2	1A893524-1A	NAETC-7024-1A,Inlet terminal PC board ass'y
U3	1A893525-1A	NASW-7025-1A,Power switch PC board ass'y
U4	1A893526-1A	NAETC-7026-1A, Power indicator PC board ass'y
U5	1A893527-1A	NAETC-7027-1A, Terminal PC board ass'y
U6	1A893528-1A	NAETC-7028-1A, Power transformer PC board ass'y

NOTE: THE COMPONENTS IDENTIFIED BY MARK △ ARE CRITICAL FOR RISK OF FIRE AND ELECTRIC SHOCK. REPLACE ONLY WITH PART NUMBER SPECIFIED.

CAUTION: Replacement for transistor of mark \* , if necessary must be made from the same beta group (HFE) as the original type.

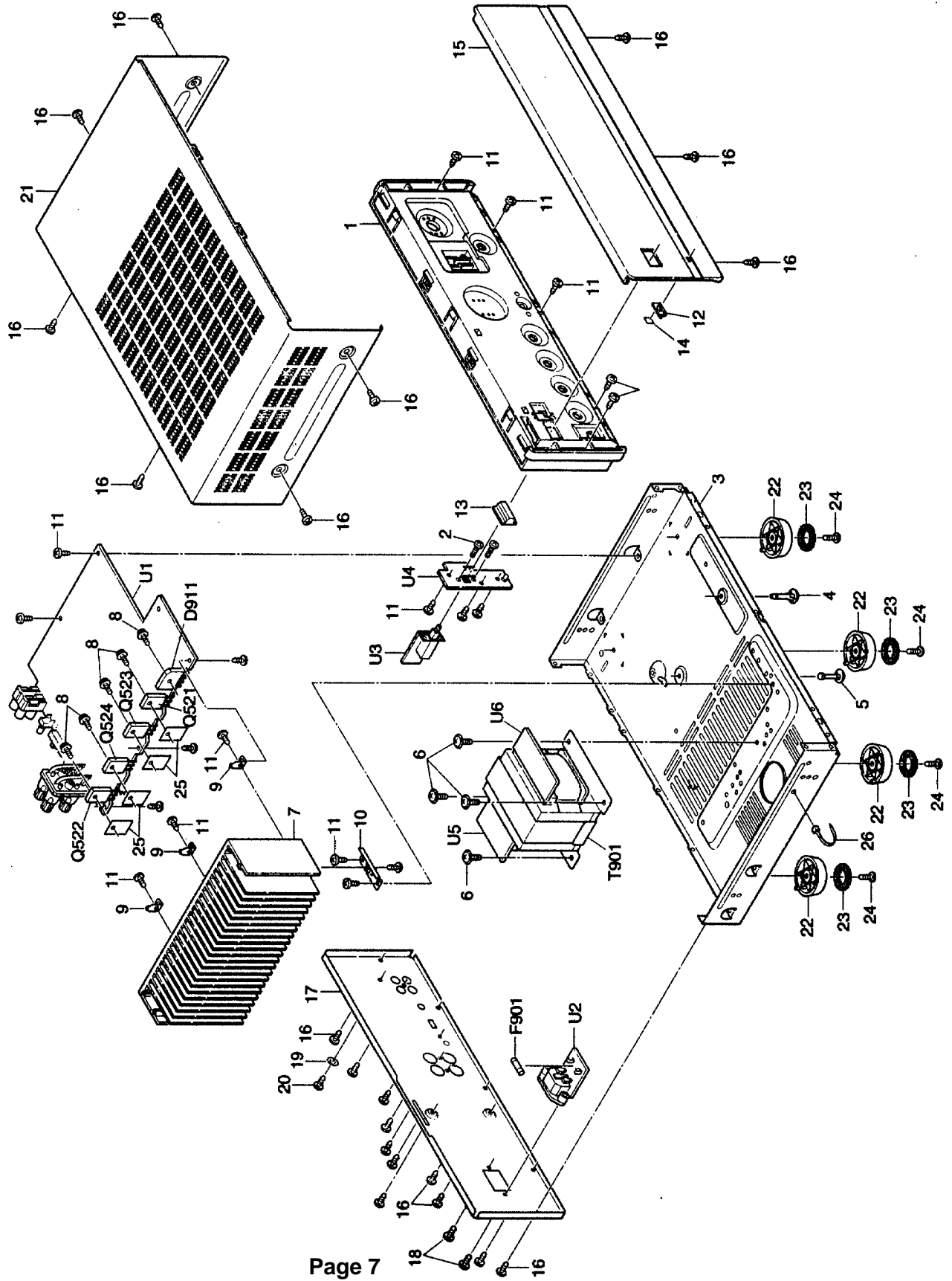







# SCHEMATIC DIAGRAM

1

2

3

4

5

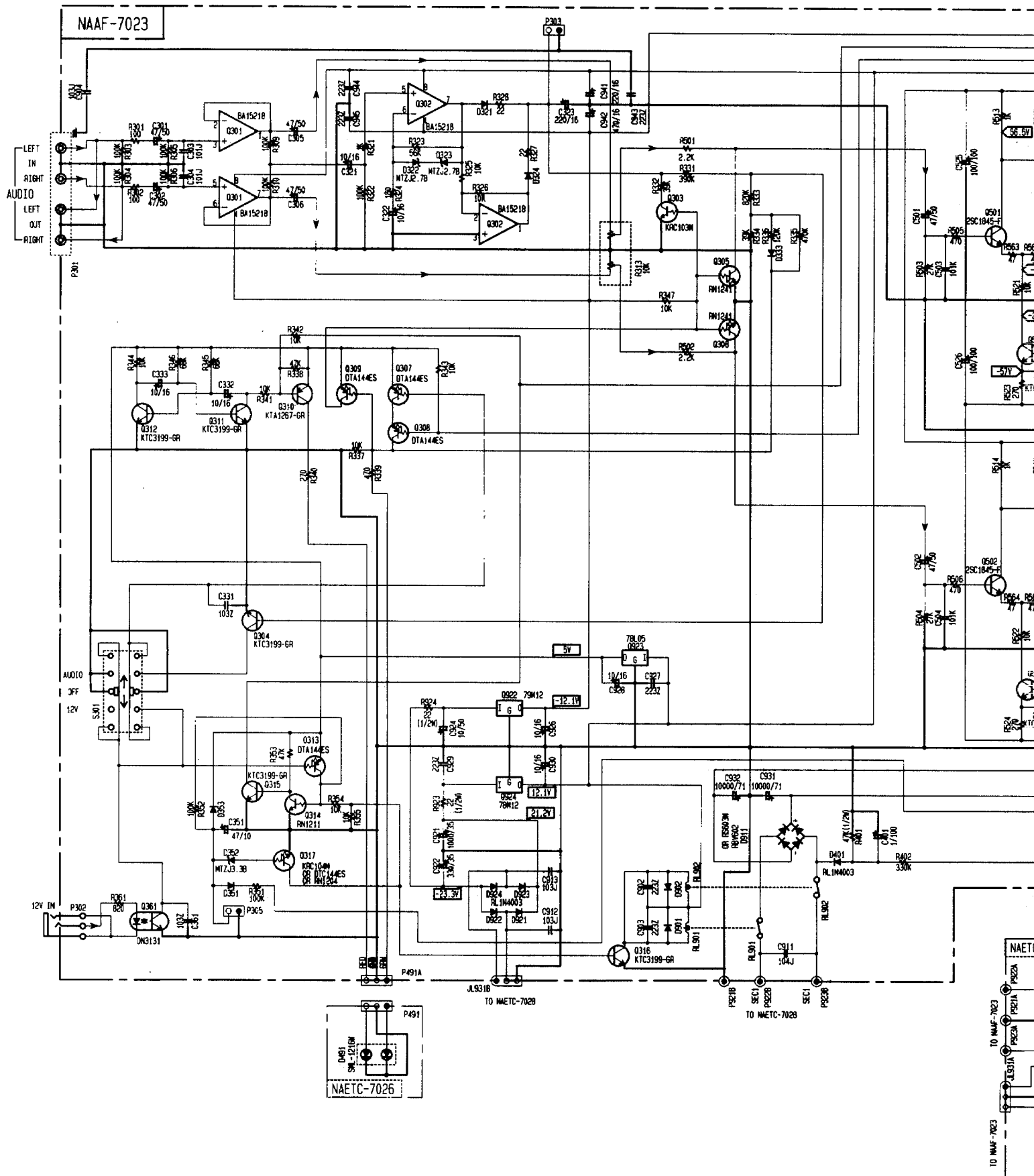

# PRINTED CIRCUIT BOARD PARTS LIST

CAUTION: Replacement for transistor of mark must be made from the same beta g the original type.

## MAIN CIRCUIT PC BOARD (NAAF-7023-1A)

CIRCUIT NO.	PART NO.	DESCRIPTION	CIRCUIT NO.	PART NO.	DESCRIPTION
<b>ICs</b>			<b>Diodes</b>		
Q301,Q302	22240111	BA15218	D321,D324	223163 or	1SS133 or
Q401	222584	TA7317P	D331-D333	223205	1SS270A
Q922	222790125	79M12HF	D322,D323	224470272	MTZJ2.7B
Q923	222780053	78L05	D352	224470332	MTZJ3.3B
Q924	222780125	78M12HF	D351,D353	223163 or	1SS133 or
<b>Transistors</b>			D501	223205	1SS270A
Q303	2215810 or	KRC103M or	D401	22380260 or	RL1N4003 or
	2213160	DTC124ES	D921-D924	22380032	1SR139-100
Q304	2215864,	KTC3199-GR,	D511,D512	223163 or	1SS133 or
Q311,Q312	2213284 or	2SC1740S-R or	D901,D902	223205	1SS270A
Q315,Q316	2213285	2SC1740S-S	<b>Coils</b>		
Q305,Q306	2213631 or	RN1241-A or	L501,L502	231176S	S-1.3C
	2213632	RN1241-B	<b>Relays</b>		
Q307-Q309	2213750 or	DTA144ES or	RL501	25065598	NRL-2P3A-DC12-148
Q313	2216310	KRA104M	RL901	25065561,	NRL-1P5A-DC12-127,
Q310	2215995,	KTA1267-GR,	RL902	25065515 or	NRL-1P5A-DC12-096 or
	2213354 or	2SA933S-R or	<b>Switch</b>		
	2213355	2SA933S-S	S301	25065609	NSS-23204
Q314	2213600,	RN1211,	<b>Capacitors</b>		
	221299 or	DTC114TS or	C301,C302	354784709	47 $\mu$ F,50V, Elect.
	2216320	KRC111M	C305,C306	354784709	47 $\mu$ F,50V, Elect.
Q317	2215820,	KRC104M,	C321,C322	354741009	10 $\mu$ F,16V, Elect.
	221282 or	DTC144ES or	C323	354742219	220 $\mu$ F,16V, Elect.
	2213560	RN1204	C332,C333	354741009	10 $\mu$ F,16V, Elect.
Q501-Q504	2211732, *	2SC1845-F,	C351	354734709	47 $\mu$ F,10V, Elect.
	2210755, *	2SC1775A-E,	C401	354790109	1 $\mu$ F,100V, Elect.
	2210756 or *	2SC1775A-F or	C403	354763309	33 $\mu$ F,35V, Elect.
	2211733 *	2SC1845-E	C404	354784799	0.47 $\mu$ F,50V, Elect.
Q505,Q506	2215843,	KTA1024-O,	C405	354721019	100 $\mu$ F,6.3V, Elect.
Q511,Q512	2211353 or	2SA949-O or	C501,C502	354784709	47 $\mu$ F,50V, Elect.
Q527,Q528	2215844	KTA1024-Y	C503,C504	374721015	100pF $\pm$ 10%,50V,Plastic
Q507,Q508	2211732,	2SC1845-F,	C507,C508	354762219	220 $\mu$ F,35V, Elect.
Q525,Q526	2210755,	2SC1775A-E,	C513,C514	354722219	220 $\mu$ F,6.3V, Elect.
	2210756 or	2SC1775A-F or	C521,C522	354784709	47 $\mu$ F,50V, Elect.
	2211733	2SC1845-E	C525,C526	354791019	100 $\mu$ F,100V,Elect.
Q509,Q510	2215864,	KTC3199-GR,	C529,C530	374721044	0.1 $\mu$ F $\pm$ 5%,50V,Plastic
Q515,Q516	2213284 or	2SC1740S-R or	C537,C538	374724734	0.047 $\mu$ F $\pm$ 5%,50V,Plastic
	2213285	2SC1740S-S	C583	354780109	1 $\mu$ F,50V, Elect.
Q513,Q514	2215853,	KTC3206-O,	C904	374721034	0.01 $\mu$ F $\pm$ 5%,50V,Plastic
	2211633 or	2SC2229-O or	C911	374731044	0.1 $\mu$ F $\pm$ 5%,100V,Plastic
	2215854	KTC3206-Y	C912,C913	374721034	0.01 $\mu$ F $\pm$ 5%,50V,Plastic
Q517,Q518	2203434 or	KTD2061-Y or	C921	354761029	1000 $\mu$ F,35V,Elect.
	2203010	2SC5171	C922	354763319	330 $\mu$ F,35V,Elect.
Q519,Q520	2203424 or	KTB1369-Y or	C924	354781009	10 $\mu$ F,50V, Elect.
	2203000	2SA1930	C926,C928	354741009	10 $\mu$ F,16V, Elect.
Q521,Q522	2202823 or *	2SC5200-O or	C930	354741009	10 $\mu$ F,16V, Elect.
	2202822 *	2SC5200-R	C931,C932	3504363	10000 $\mu$ F,71V,Elect.
Q523,Q524	2202813 or *	2SA1943-O or	C941	354742219	220 $\mu$ F,16V, Elect.
	2202812 *	2SA1943-R	C942	354744719	470 $\mu$ F,16V, Elect.
Q583	2211792,	2SA992-F,	<b>Resistors</b>		
	2211793 or	2SA992-E or	R313	5112484	N09RGL10KB14F,Variable
	2215885	KTA1268-GR	R401	443524734	47k $\Omega$ $\pm$ 5%,1/2W,Metal oxide
<b>Photo coupler</b>			R511,R512	443526804	68 $\Omega$ $\pm$ 5%,1/2W,Metal oxide
Q361	24120043,	ON3131,	R529-R532	443521014	100 $\Omega$ $\pm$ 5%,1/2W,Metal oxide
	24120044 or	ON3131-R or	R533,R534	5210259	N06HR2KBC,Trimming
	24120045	ON3131-S	R539,R540	443521014	100 $\Omega$ $\pm$ 5%,1/2W,Metal oxide

CIRCUIT NO.	PART NO.	DESCRIPTION
<b>Resistors</b>		
R541,R542	443528204	82 $\Omega$ $\pm$ 5%,1/2W,Metal oxide
R545,R546	4000201 or	RF-5EGKR22 or
R545,R546	4000132	RGC55 0.22, Metal plate
R551,R552	453630824	8.2 $\Omega$ $\pm$ 5%,1W,Metal
R581,R582	443523314	330 $\Omega$ $\pm$ 5%,1/2W,Metal oxide
R583-R586	453530224	2.2 $\Omega$ $\pm$ 5%,1/2W,Metal
R591,R592	4500171F	2.2 $\Omega$ $\pm$ 5%,1/4W,Metal
R923,R594	443522204	22 $\Omega$ $\pm$ 5%,1/2W,Metal oxide
<b>Terminals</b>		
P301	25045582 or	NPJ-4PDRW393 or
	25045491	NPJ-4PDBL308
P302	25045504	NPJ-1PDBL319
P501	25060300	NTM-4PDMN231
<b>Socket</b>		
JL931B	25051107	NSCT-3P894
<b>Plugs</b>		
P303,P305	25055038	NPLG-2P29
P491A	25055441	NPLG-3P423
P511,P512	25055038	NPLG-2P29
<b>Heat sink</b>		
Q924A	27160176	HEAT-SINK
<b>Screw</b>		
Q924B	82143010	3P+10FN(BC),Pan head

**INLET TERMINAL PC BOARD (NAETC-7024-1A)**

CIRCUIT NO.	PART NO.	DESCRIPTION
P901A	25055960	$\Delta$ NPLG-2P913, Inlet
F901A	252164	$\Delta$ 5A-UL/T-237, Fuse
F901,F902	25052133	$\Delta$ NSCT-1P2031,Fuse holder

**POWER SWITCH PC BOARD (NAETC-7025-1A)**

CIRCUIT NO.	PART NO.	DESCRIPTION
S901	25035550	$\Delta$ NPS-111-L512P,Switch
C901	3500196S	$\Delta$ RE275V-103M,IS capacitor

**POWER INDICATOR PC BOARD (NAETC-7026-1A)**

CIRCUIT NO.	PART NO.	DESCRIPTION
D491	225375	SML1216C,LED
P491	2002E280630	NSAS-6P0904,Socket

**POWER TRANSFORMER PC BOARD (NAETC-7028-1A)**

CIRCUIT NO.	PART NO.	DESCRIPTION
R991,R992	453530224	$\Delta$ 2.2 $\Omega$ $\pm$ 5%,1/2W,Metal
JL931A	25051107	NSCT-3P894,Socket

NOTE: THE COMPONENTS IDENTIFIED BY MARK  $\Delta$  ARE CRITICAL FOR RISK OF FIRE AND ELECTRIC SHOCK. REPLACE ONLY WITH PART NUMBER SPECIFIED.

**BLOCK DIAGRAM**

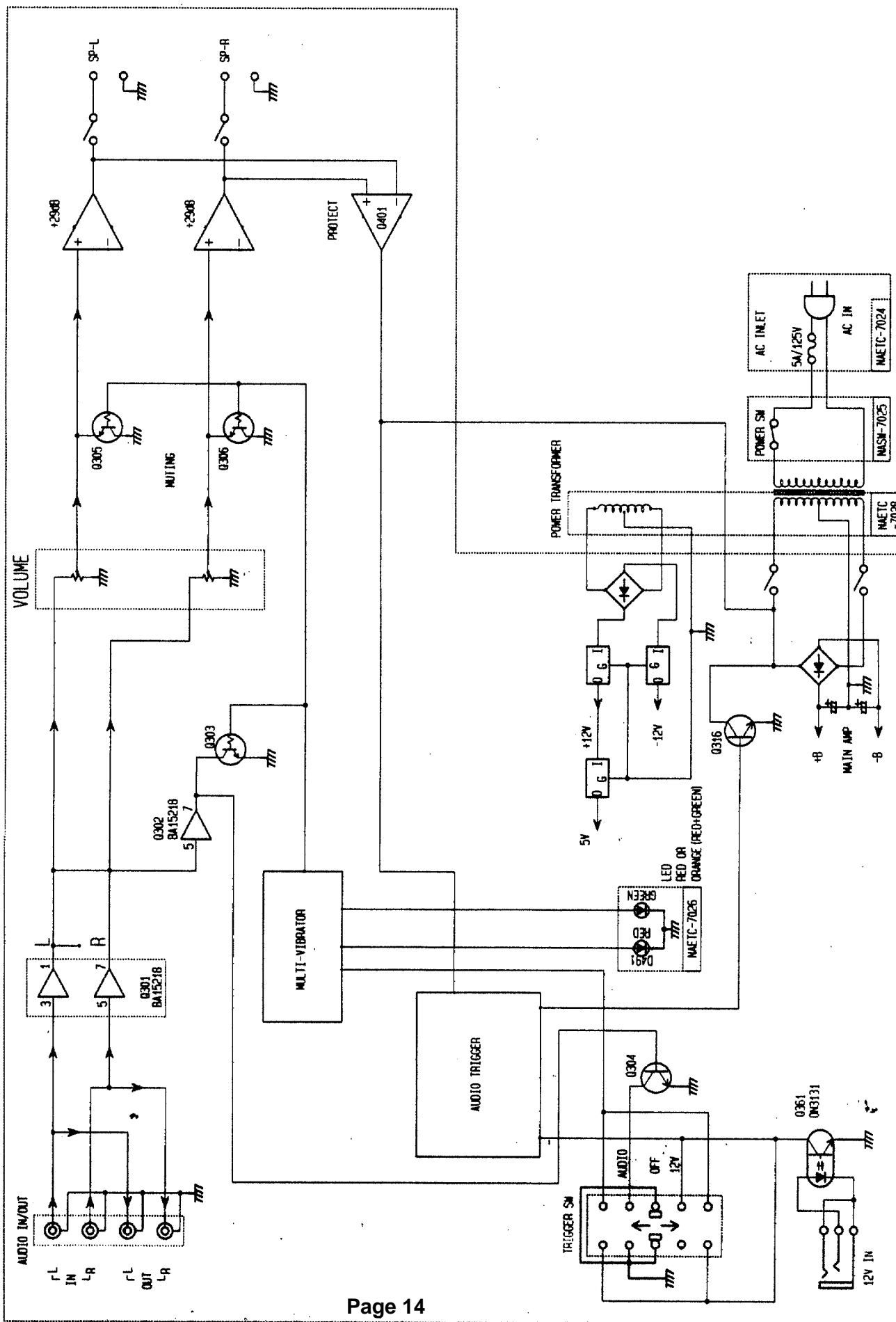

# PACKING VIEW

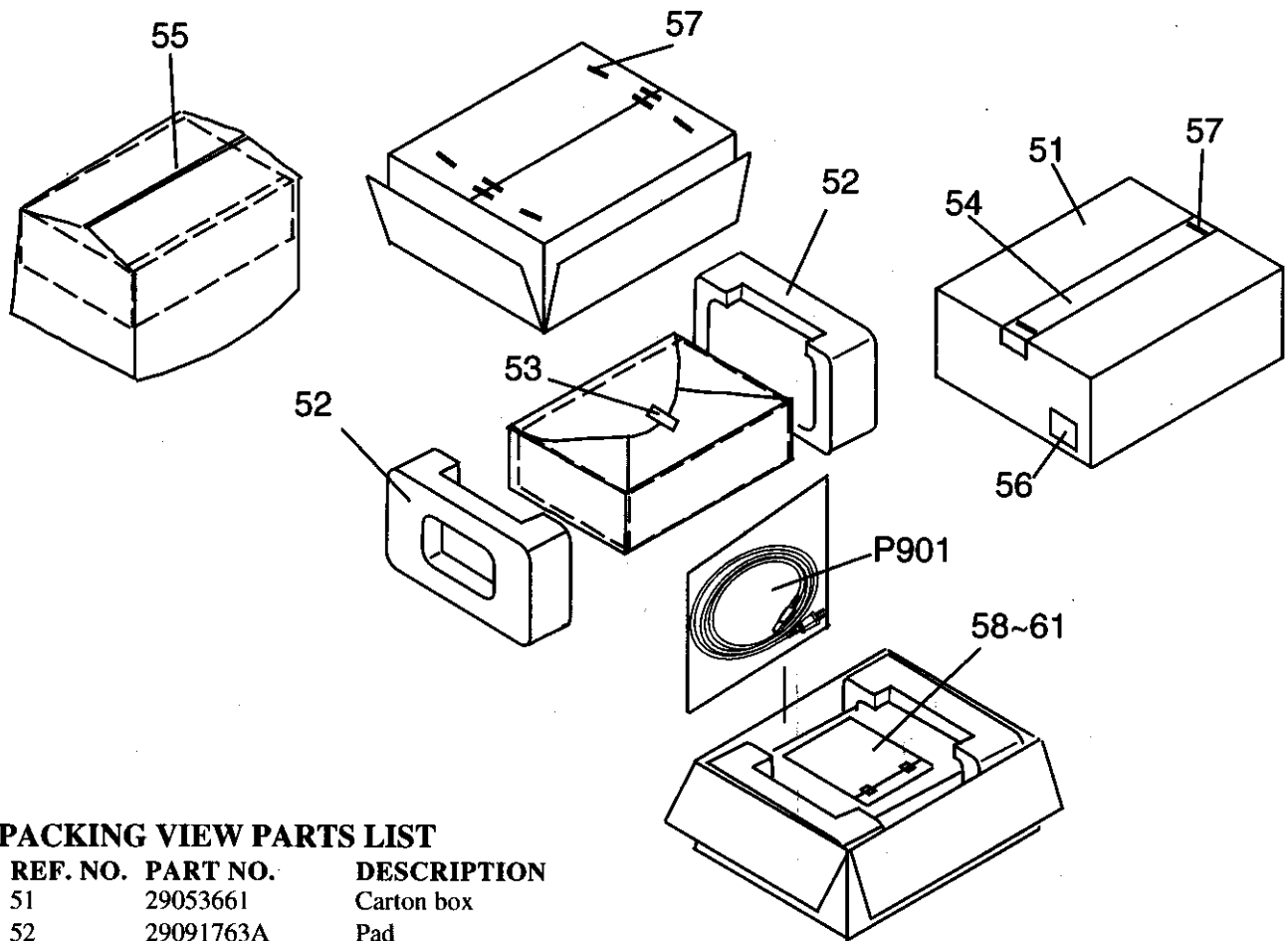

## PACKING VIEW PARTS LIST

REF. NO.	PART NO.	DESCRIPTION
51	29053661	Carton box
52	29091763A	Pad
53	261504	Paper tape
54	29110098	PP tape
55	29100034-1A	850*650, Polybag
56	29362761	Label UPC
57	282301	Staple
58	29100097-1A	350*250, Polybag
59	29343003	Instruction manual
60	29365083A	Warranty card
61	29095866	Sheet
P901	253297KAW ▲	AS-UC-2, Power supply cord

## ONKYO CORPORATION

Sales & Product Planning Div. : 2-1, Nisshin-cho, Neyagawa-shi, OSAKA 572-8540, JAPAN  
Tel: 072-831-8111 Fax: 072-833-5222

## ONKYO U.S.A. CORPORATION

200 Williams Drive, Ramsey, N.J. 07446, U.S.A.  
Tel: 201-825-7950 Fax: 201-825-8150 E-mail: onkyousa.com