

ONKYO SERVICE MANUAL

QUARTZ SYNTHESIZED TUNER AMPLIFIER MODEL R-30

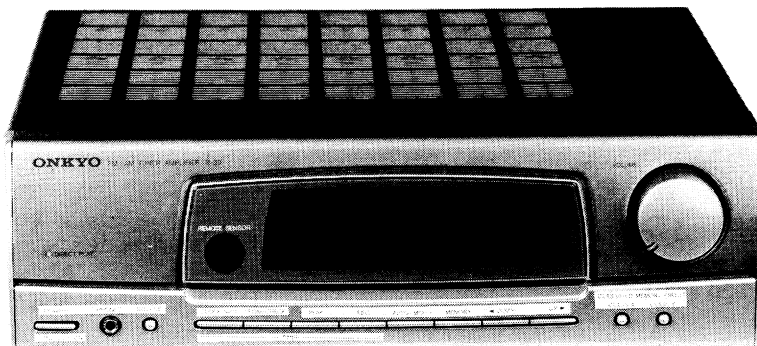

Black and Silver models

MD, MDN, BHMD, BHMDN	120V AC, 60Hz
MP, MPV, MPF, BHMP, BHMPV, BHMPF	230V AC, 50Hz
MW, BHMW	120 or 220V AC, 50/60Hz
MQA, BHMQA	240V AC, 50Hz

SAFETY-RELATED COMPONENT WARNING!!
COMPONENTS IDENTIFIED BY MARK Δ ON THE SCHEMATIC DIAGRAM AND IN THE PARTS LIST ARE CRITICAL FOR RISK OF FIRE AND ELECTRIC SHOCK. REPLACE THESE COMPONENTS WITH ONKYO PARTS WHOSE PART NUMBERS APPEAR AS SHOWN IN THIS MANUAL.

MAKE LEAKAGE-CURRENT OR RESISTANCE MEASUREMENTS TO DETERMINE THAT EXPOSED PARTS ARE ACCEPTABLY INSULATED FROM THE SUPPLY CIRCUIT BEFORE RETURNING THE APPLIANCE TO THE CUSTOMER.

TABLE OF CONTENTS

Specifications	2
Service procedures	3
Exploded view	4
Parts list	5
Block diagram.....	6
120V model.....	6
Other models.....	7
Microprocessor connection diagram	8
Terminal descriptions.....	9
IC block diagrams and descriptions	10
Adjustment procedures.....	14
Printed circuit board view from bottom side	17
Schematic diagram	19
120V model.....	19
Other models.....	23
Printed circuit board parts list	29
Packing view	32



SPECIFICATIONS

Tuner Amplifier R-30

Amplifier section

Power Output:	30 watts per channel, min. RMS, at 6 ohms, both channels driven, from 40 Hz to 20 kHz, with no more than 0.5 % THD.
Musical Power Output:	2 x 45 watts at 6 ohms, 1 kHz (DIN)
Continuous Power Output:	2 x 32 watts at 6 ohms, 1 kHz (DIN)
Total Harmonic Distortion:	0.5 % at rated power
IM Distortion:	0.5 % at rated power
Damping Factor:	25 at 6 ohms
Frequency Response:	40 – 20,000 Hz \pm 3 dB (DIRECT)
Sensitivity and Impedance:	
CD/Tape Play:	150mV/50 kohms
Tape Rec:	150 mV/3.5 kohms
Mono out:	IV, 600 ohms
Signal-to-Noise Ratio:	
CD/Tape:	100dB (IHF-A)
Phono:	80dB (IHF-A)
Tone Controls:	
Super Bass:	+15dB at 45Hz
Bass:	\pm 10dB at 100Hz
Treble:	\pm 10dB at 10kHz
Muting:	-45dB

Tuner section

FM:

Tuning Range:	
European models:	87.5 – 108.0MHz (50kHz steps)
U.S.A. and Canadian models:	87.9 – 107.9MHz (200kHz steps)
Usable Sensitivity:	
Mono:	11.2 dBf, 1.0 μ V, 75 ohms 0.9 μ V (S/N 26dB, 40kHz Devi.) 75 ohms DIN
Stereo:	18.0dBf, 2.2 μ V, 75 ohms 23 μ V (S/N 46dB, 40kHz Devi.) 75 ohms DIN
50dB Quieting Sensitivity:	
Mono:	18.2dBf, 2.2 μ V, 75 ohms
Stereo:	37.2dBf, 20 μ V, 75 ohms
Capture Ratio:	1.5dB
Image Rejection Ratio:	85dB
IF Rejection Ratio:	90dB
Signal-to-Noise Ratio:	
Mono:	73dB
Stereo:	66dB
Selectivity:	50dB DIN (\pm 300kHz, 40kHz dev.)
AM Suppression Ratio:	50dB
Harmonic Distortion:	
Mono:	0.15%
Stereo:	0.30%
Frequency Response:	30 – 15,000Hz \pm 1.5dB
Stereo Separation:	40dB at 1kHz

AM:

Tuning Range:	
European models:	522 – 1611kHz (9kHz steps)
U.S.A. and Canadian models:	530 – 1710kHz (10kHz steps)
Saudi Arabia and Worldwide models:	531 – 1602kHz (9kHz steps)
Usable Sensitivity:	30 μ V
Image Rejection Ratio:	40dB
IF Rejection Ratio:	40dB
Signal-to-Noise Ratio:	40dB
Harmonic Distortion:	0.8%

General

Power Supply:	
European models:	AC230V, 50Hz
U.S.A. and Canadian models:	AC120V, 60Hz
U.K. and Australian models:	AC 240V, 50Hz
Worldwide models:	120 and 220V switchable, 50/60Hz
Dimensions (W x H x D):	275 x 85 x 317 mm 10 13/16" x 3 3/8" x 12 1/2"
Weight:	4.5kg., 9.9lbs.

Remote control transmitter RC-229S

Transmitter:	Infrared
Signal range:	Approx. 5 meters (16ft. 4")
Power supply:	Two "AA" batteries (1.5V x 2)

SERVICE PROCEDURES

1. Replacing the fuses

For continued protection against fire hazard, replace only with same type and same rating fuse.

CircuitNo. PartNo. Description

F901 252149 Δ 2.5A-TSC, Primary fuse (D/W)

F901 252071 Δ 1.25A-SE-EAK, Primary fuse
(P/Q)

F902 252071 Δ 1.25A-SE-EAK, AC outlet fuse (P)

F902 252071 Δ 1.25A-SE-EAK,
Primary fuse (W)

NOTE: (D) :Only 120V model

(P) :Only 230V model

(W) :Only Worldwide model

(Q) :Only 240V model

2. Change of FM/AM band step

With the exception of the Worldwide model, a BAND STEP selector switch is not provided.

(FM)

BAND STEP	J719	J720
200kHz→50kHz	Short	Open
50kHz→200kHz	Open	Open

(AM)

BAND STEP	J721
10kHz→9kHz	Short
9kHz→10kHz	Open

—Worldwide model—

Worldwide models are equipped with a step band selector switch. This switch is located on the back panel. This switch is set to 50kHz(FM) and 9kHz(AM) at the factory, but may have to be reset to 100kHz and 10kHz depending on the area where the unit is used.

	FM step	AM step
Europe:	50kHz	9kHz
U.S.A.:	200kHz	10kHz

3. Memory preservation

This unit does not require memory preservation batteries. A built-in memory power back-up system preserves contents of the memory during power failures and even when the unit is unplugged. The unit must be plugged in and the power switch turned on and off once in order to charge the back-up system. Note that since this is not a permanent memory the power switch must be turned on and off a few times each month to keep the back-up system operative. The period of time during which memory contents are preserved after power has last been turned off varies depending on climate and placement of the unit. On the average, memory contents are protected over a period of 3 to 4 weeks (a minimum of 2 weeks) after the last time power has been turned off. This period is shorter when the unit is exposed to very high humidity or used in an area with an extremely humid climate.

4. Safety-check out

(Only U.S.A. model)

After correcting the original service problem perform the following safety check before releasing the set to the customer.

Connect the insulating-resistance tester between the plug of power supply cord and terminal GND on the back panel. Specifications: 3.3 Mohm \pm 10% at 500V.

5. Change of voltage

Worldwide models are equipped with a voltage selector to conform with local power supplies. This switch is located on the back panel. Be sure to set this switch to match the voltage of the power supply in your area before turning the power switch on.

This switch is set to 220V at the factory. Voltage is changed by sliding the groove in the switch with the screwdriver to the right or left. Confirm that the switch has been moved all the way to the right or left before turning the power switch on.

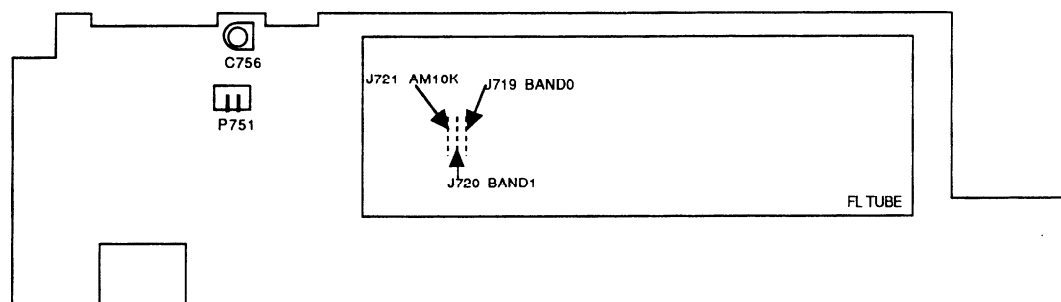

EXPLODED VIEW

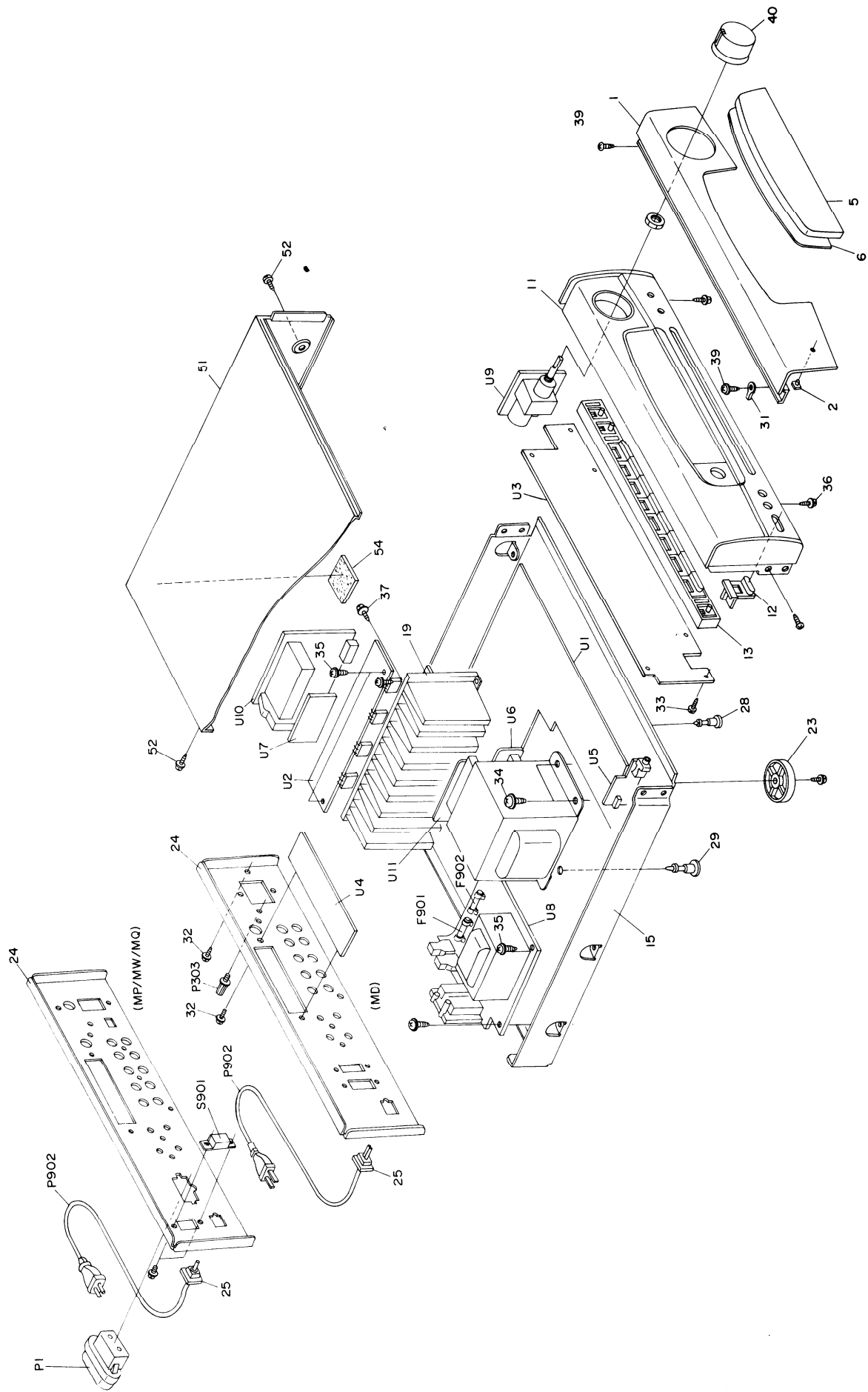

PARTS LIST

REF.NO.	PART NO.	DESCRIPTION	REF.NO.	PART NO.	DESCRIPTION	REF.NO.	PART NO.	DESCRIPTION
1	27211430B	Front panel <S>	P901	252149	2.5A-TSC,Primary fuse <D/W>	UB	1A366544-1	NAPS-4544-1,Power supply circuit pc board ass'y <D>
2	27211431B	Front panel 	P902	252071	1.25A-SE-EAK,Primary fuse <P>			
5	28158782Y	Facet	P903	25060044	1.25A-SE-EAK,Primary fuse <P/W>			
6	28151632B	Clear plate <S>	P901	25050337	Ground terminal			
	28151633B	Clear plate 	P902	253173Y or	NSCT-2P164,AC outlet <P/W>			
11	28133286-1	Back plate <S>		25050346	NSCT-2P173,AC outlet <Q>			
	28133287-1	Back plate 		253142HITSY	AS-UC-7#18,			
	27110710BY	Front bracket <S>		253164Y or	Power supply cord <D>			
	27110711BY	Front bracket 		253175Y	AS-CEE,	U9	1A366545-1	NAAF-4545-1,Volume circuit, pc board ass'y
12	28324637Y	Knob,power <S>		253170	Power supply cord <P/W>	U10	1A366546-1	NARF-4546-1,Front end circuit pc board ass'y <D>
	28324638Y	Knob,power 	Q505,Q506	2202303,	AS-SAA,Power supply cord <Q>			
13	28324639Y	Knob,selector <S>		2202304 or	25C4512-O,			
	28324640Y	Knob,selector 		2202305	25C4512-Y or	U11	1A366547-1	NAETC-4547-1,Power transformer pc board
15	27100259AY	Chassis	Q507,Q508	2202313,	25A1726-P,Power amplifier transistors			
17	27150347Y	Shield plate (knob)		2202314 or	25A1726-Y or			
19	27160312BY	Radiator	S901	2202315	2SA1726-P,Power amplifier transistors			
23	27175252-1AY	Leg	T901	2300812Y	NSS-22113P,Voltage selector switch <W>			
24	27121598Y	Rear panel <D>		2300813Y	NPT-1146D,Power transformer <D>			
	27121599Y	Rear panel <P>		2300814Y	NPT-1146F,Power transformer <P>			
	27121623Y	Rear panel <V>		2300815Y	NPT-1146DG,Power transformer <W>			
	27121600Y	Rear panel <W>	U1	1A366538-1	NPT-1146Q,Power transformer <Q>			
	27121601AY	Rear panel <Q>		1A366538-1A	NAAR-4538-1,Main circuit pc board ass'y <D>			
25	27300750	Bushing,cord		1A366538-1B	NAAR-4538-1A,Main circuit pc board ass'y <P/Q>			
28	27190428A	KGLS-10RT,Holder	U2	1A366539-1	NAAR-4538-1B,Main circuit pc board ass'y <W>			
29	27190524	KGLS-14RT,Holder	U3	1A366540-1	NAAF-4539-1,Main amplifier circuit pc board ass'y			
31	2061112100	Cord ass'y		1A366540-1A	NADG-4540-1,Microprocessor circuit pc board ass'y <D>			
32	834430088	3TTS-8B(BC),Self-tapping screw		1A366540-1B	NADG-4540-1A,Microprocessor circuit pc board ass'y <P/Q>			
33	833426080	2.6TTB-8B(BC),Self-tapping screw	U4	1A366541-1	NADG-4540-1B,Microprocessor circuit pc board ass'y <W>			
34	830440089	4TTC-8C(BC),Self-tapping screw		1A366541-1A	NAETC-4541-1,Speaker terminal pc board ass'y <D>			
35	831130088	3TTW-8B,Self-tapping screw			NAETC-4541-1A,Speaker terminal pc board ass'y <P/W/Q>			
36	838430088	3TTB-8B(BC),Self-tapping screw	U5	1A366542-1	NASW-4542-1,Headphone terminal pc board ass'y			
37	801433	3SMS8W,SW+14B(BC),Self-tapping screw	U6	1A366543-1	NAETC-4543-1,Power transformer pc board			
39	833430080	3TTP-8P(BC),Self-tapping screw	U7	1A366557-1	NAAF-4557-1,Equalizer amplifier pc board ass'y			
40	28324641Y	Knob,volume <S>						
	28324642Y	Knob,volume 						
51	28184519Y	Top cover						
52	838430088	3TTB-8B(BC),Self-tapping screw						
54	28141184	Cushion						
55	834230108	3TTS-10B(Ni),Nickel self-tapping screw <P/W/Q>						

NOTE: <D>:120 V model only
 <P>:230 V model only
 <Q>:240 V model only
 <W>:Worldwide model only
 <V>:Germany model only
 <S>:Silver model only
 :Black model only

NOTE: THE COMPONENTS IDENTIFIED BY MARK  ARE CRITICAL FOR RISK OF FIRE AND ELECTRIC SHOCK. REPLACE ONLY WITH PARTS NUMBER SPECIFIED.

BLOCK DIAGRAM

-120V MODEL-

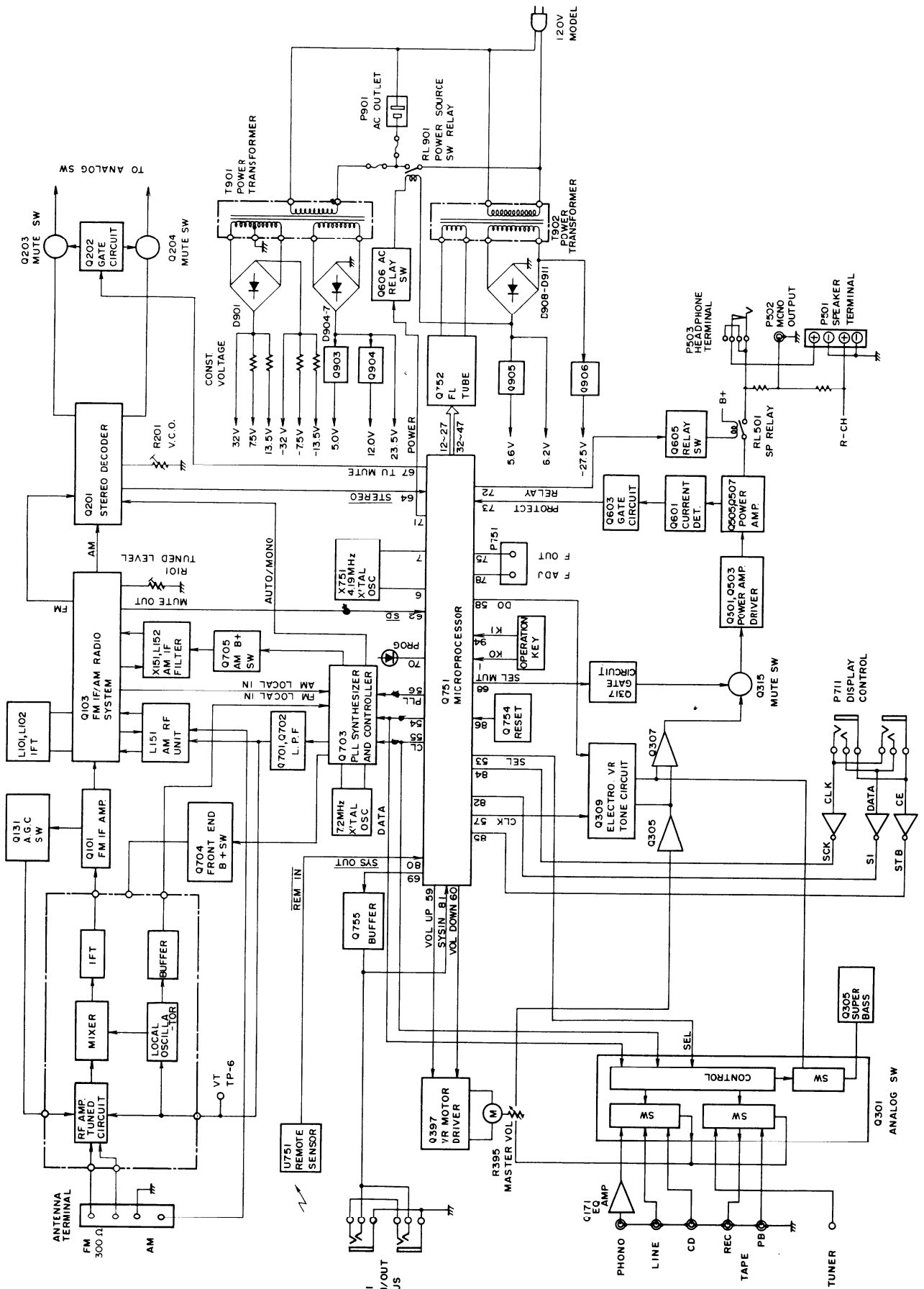

MICROPROCESSOR CONNECTION DIAGRAM

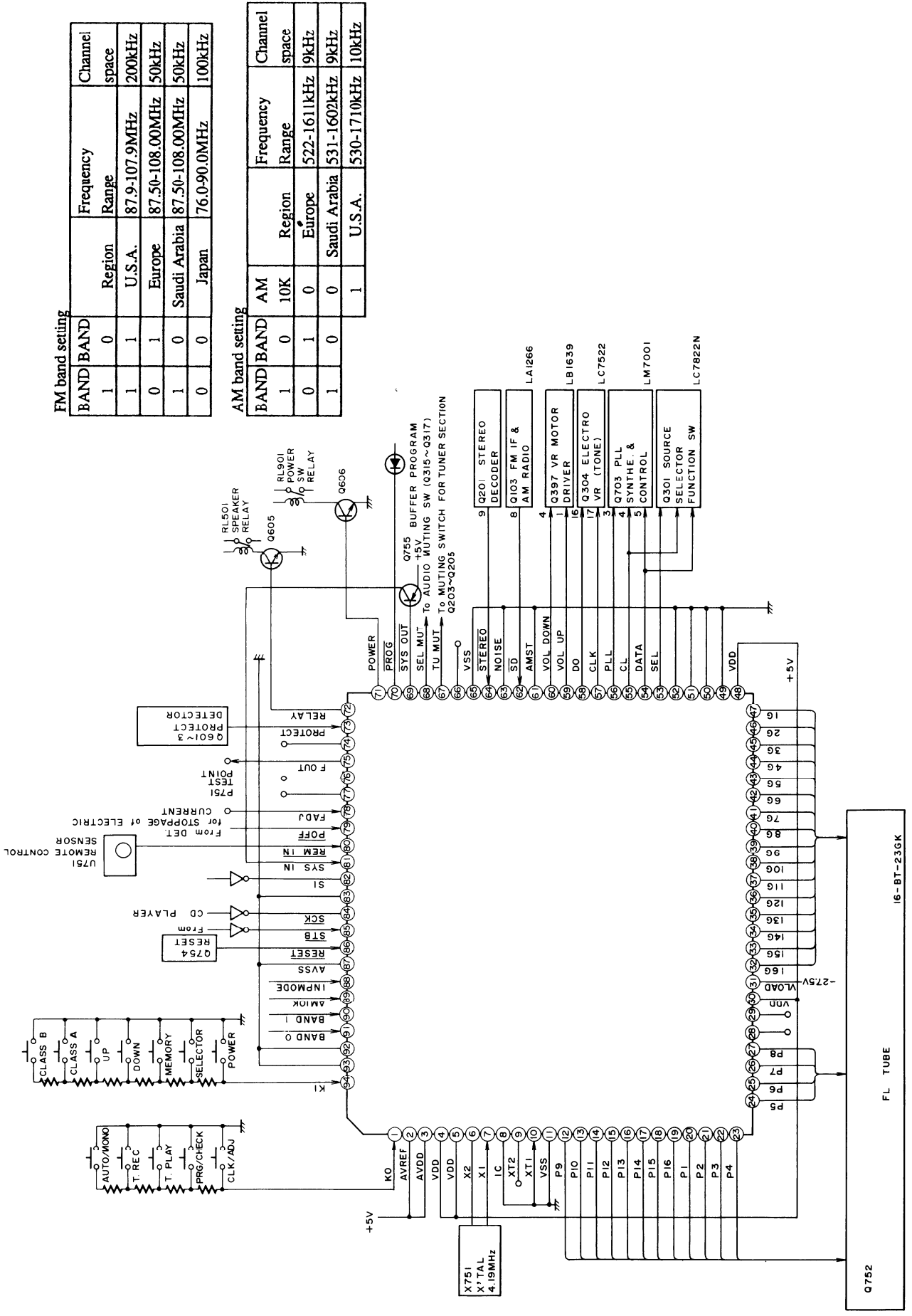

FM band setting

BAND	Region	Frequency Range	Channel space
1	U.S.A.	87.9-107.9MHz	200kHz
0	Europe	87.50-108.00MHz	50kHz
1	Saudi Arabia	87.50-108.00MHz	50kHz
0	Japan	76.0-90.0MHz	100kHz

AM band setting

BAND	Region	Frequency Range	Channel space
1	U.S.A.	530-1710kHz	10kHz
0	Europe	522-1611kHz	9kHz
1	Saudi Arabia	531-1602kHz	9kHz
0	U.S.A.	530-1710kHz	10kHz

TERMINAL DESCRIPTIONS

Pin No.	Symbol	Description
1	K0	Operation key input terminal
2	AVREF	Reference voltage input terminal for AD converter
3	AVDD	Power supply terminal for AD converter (+5V)
4	VDD	Positive power supply terminal (+5V)
5	VDD	Positive power supply terminal (+5V)
6	X2	Crystal oscillator connection terminals for main system clock.
7	X1	Connect the 4.19MHz crystal oscillator.
8	IC	Internal connection terminal. Connect to the ground.
9	XT2	Not used.
10	XT1	Not used. Connect to the ground.
11	VSS	Ground terminal
12~19	P9~P16	Segment output terminals
20~27	P1~P8	Segment output terminals
28,29	NC	Not used.
30	VDD	Positive power supply terminal (+5V)
31	VLOAD	Pull down resistor connection terminal for controller and driver
32~47	I6G~I1G	Grid output terminals
48	VDD	Positive power supply terminal (+5V)
49~52	NC	Not used.
53	SEL	Connect to the terminal CE of the function switch LC7822N.
54	DATA	Connect to the terminal DI of the function switch LC7822N and the terminal DATA of PLL IC LM7001.
55	CL	Connect to the terminal CL of the function switch LC7822N and the terminal CL of PLL IC LM7001.
56	PLL	Connect to the terminal CE of PLL IC LM7001.
57	CLK	Connect to the terminal CLK of the electro volume LC7522.
58	DO	Connect to the terminal DI of the electro volume LC7522.
59	VOL UP	Volume control output terminals.
60	VOL DOWN	Operation #59 #60
		STOP H H
		UP H L
		DOWN L H
		Power off L L

Pin No.	Symbol	Description
61	NC	Not used.
62	SD	Broadcast detection input terminal
63	NOISE	Noise detection terminal. Not used.
64	STERBO	FM stereo broadcast detection input terminal
65	VSS	Ground terminal
66	NC	Not used.
67	TU MUT	Muting output terminal of tuner section
68	SEL MUT	Muting output terminal of amplifier section
69	SYSOUT	System code output terminal
70	PROG	Program indication output terminal
71	POWER	Power source relay control output terminal
72	RELAY	Speaker relay control output terminal
73	PROTECT	Protection circuit operation detection input terminal
74	NC	Not used.
75	FOUT	Output terminal for the frequency adjustment of the crystal oscillation
76,77	NC	Not used.
78	FADI	Crystal oscillation adjustment mode input terminal
79	POFF	Detection input terminal for the stoppage of electric current
80	REM IN	Remote control signal input terminal
81	SYS IN	System code input terminal
82	SI	Serial data input terminal for indication from CD player
83	NC	Not used.
84	SCK	Serial clock input terminal for indication from CD player
85	STB	Strobe signal input terminal of serial data for indication from CD player
86	RESET	Reset input terminal
87	AVSS	Reference ground terminal of AD converter
88	INPMODE	Initializing input terminal for operation mode changeover of input selector
89	AM10K	Initializing input terminal for the region of AM band setting
90	BAND1	Initializing input terminal for the region of FM band setting
91	BAND0	Initializing input terminal for the region of FM band setting
92,93	NC	Not used.
94	K1	Operation key input terminal

IC BLOCK DIAGRAMS AND DESCRIPTIONS

16-BT-23GK (Fluorescent Indicator Tube)

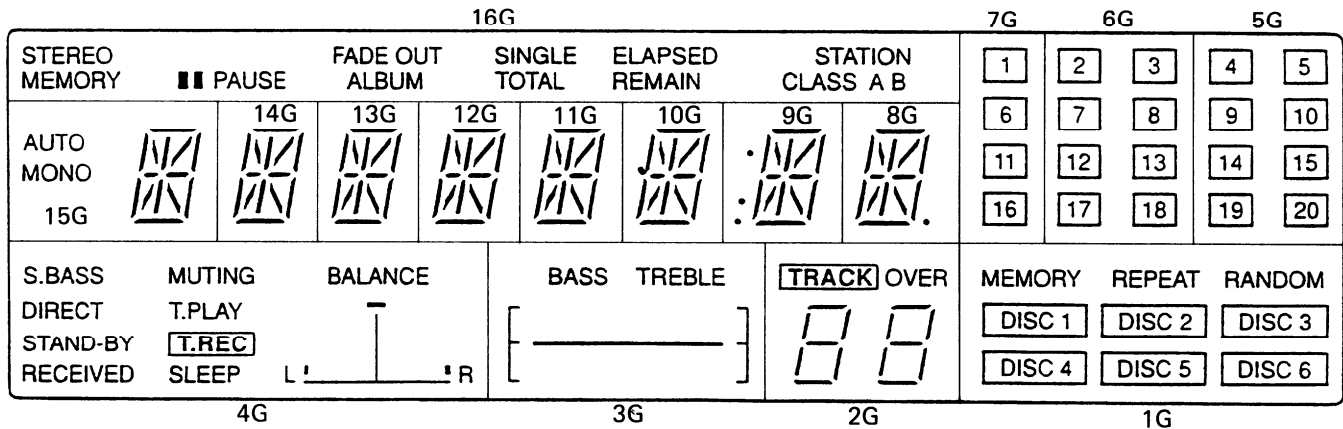

	16G	15G	14G	13G	12G	11G	10G	9G	8G	7G	6G	5G	4G	3G	2G	1G
P1	STEREO	AUTO	-	-	-	-	-	-	-	<1>	<2>	<4>	S.BASS	S2	TRACK	MEMORY
P2	MEMORY	MONO	-	-	-	-	-	-	-	<6>	<7>	<9>	DIRECT	B1	2a	REPEAT
P3	PAUSE	h	h	h	h	h	h	h	h	<11>	<12>	<14>	STAND-BY	B2	2b	RANDOM
P4	FADE OUT	b	b	b	b	b	b	b	b	<16>	<17>	<19>	RECEIVED	B3	2f	<DISC1>
P5	ALBUM	m	m	m	m	m	m	m	m	-	<3>	<5>	MUTING	B4	2g	<DISC2>
P6	SINGLE	c	c	c	c	c	c	c	c	-	<8>	<10>	T.PLAY	B5	2c	<DISC3>
7P	TOTAL	r	r	r	r	r	r	r	r	-	<13>	<15>	T.REC	B6	2e	<DISC4>
P8	ELAPSED	p	p	p	p	p	p	p	p	-	<18>	<20>	SLEEP	-	2d	<DISC5>
P9	REMAIN	a	a	a	a	a	a	a	a	1	2	4	S1	-	OVER	<DISC6>
P10	STATION	j	j	j	j	j	j	j	j	6	7	9	L3	B7	1a	DISC1
P11	CLASS	k	k	k	k	k	k	k	k	11	12	14	L2	B8	1b	DISC2
P12	A	f	f	f	f	f	f	f	f	16	17	19	L1	B9	1f	DISC3
P13	B	g	g	g	g	g	g	g	g	-	3	5	R1	B10	1g	DISC4
P14	C	e	e	e	e	e	e	e	e	-	8	10	R2	B11	1c	DISC5
P15	D	n	n	n	n	n	n	n	n	-	13	15	R3	B12	1e	DISC6
P16	-	d	d	d	d	d	d	d	d	-	18	20	-	-	1d	-

TC74HC14AP (Hex Inverting Schmitt Trigger)

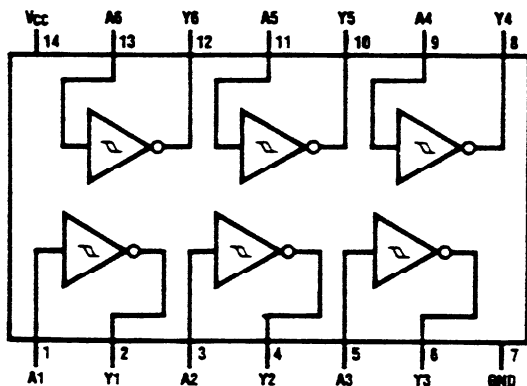

LC7822N (Analog Switch)

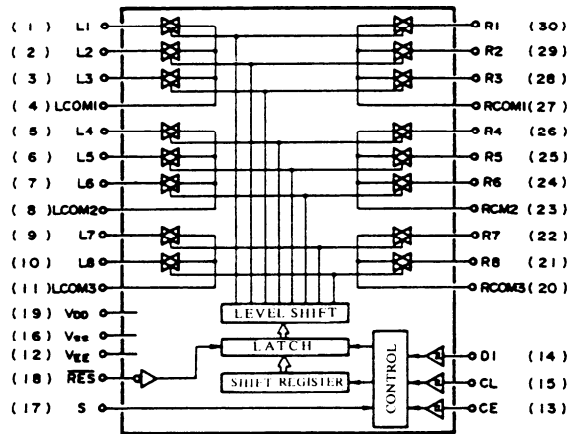

Pin No.	Terminal	Description	
1,30	PHONO	Input/output terminals of analogue switches.	
2,29	LINE		
3,28	CD		
4,27	LCOM1		
5,26	TUNER		Change over the analogue switch at the serial data of microprocessor.
6,25	TAPE REC.		
7,24	TAPE PLAY		
8,23	LCOM2		
9,22	S.BASS		
10,21			
11,20	LCOM3		
12	VEE	Negative power supply terminal.(-15V)	
13	CE	Chip enable terminal.Connect to the terminal PLL of the microprocessor.	
14	DI	Serial data input terminal.Connect to the terminal DATA of the microprocessor.	
15	CL	Serial clock terminal.Connect to the terminal CL of the microprocessor.	
16	Vss	Ground terminal.	
17	S	Select terminal.	
18	RES	Reset terminal.	
19	VDD	Power supply terminal.(+5V)	

AN7470 (FM Stereo Decoder)

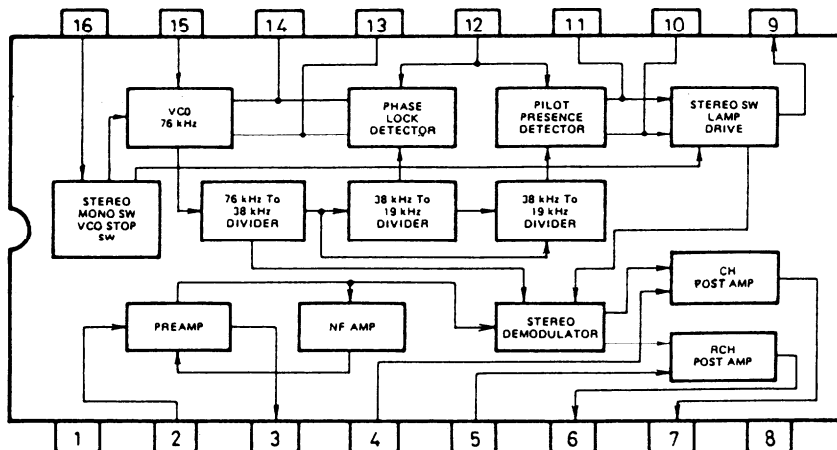

LC7522 (Electro Volume)

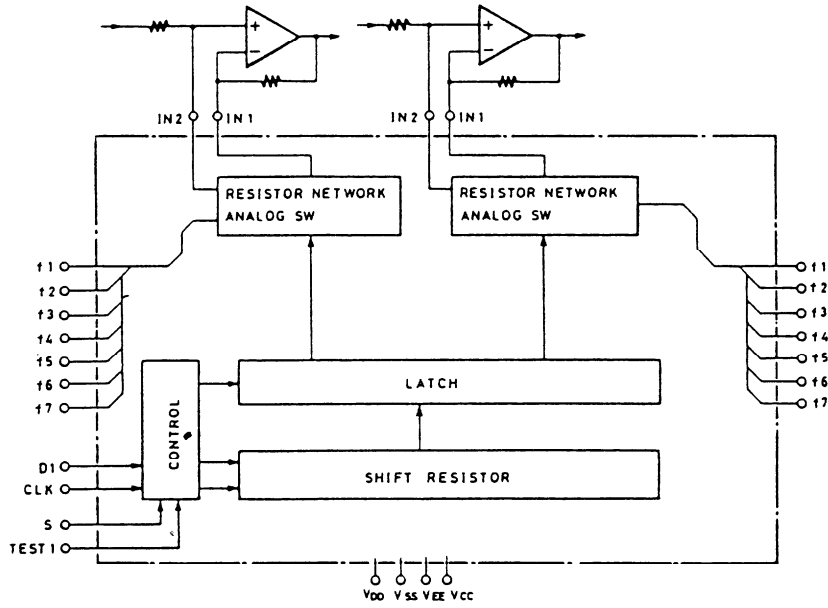
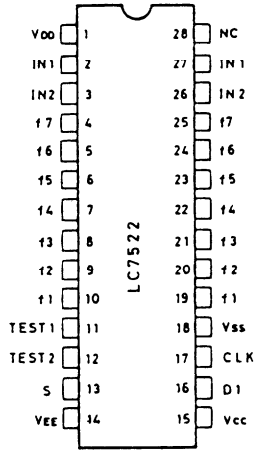

Pin No.	Symbol	Description
1	VDD	Positive power supply for audio signal.
2,27	IN1	Audio signal input terminal.
3,26	IN2	Audio signal input terminal.
4~10 19~25	f1~f7	Band pass filter connection terminal.
11	TEST1	Test terminal.
12	TEST2	
13	S	Selector terminal.
14	VEE	Negative power supply for audio signal.
15	VCC	Power supply terminal.
16	DI	Data input terminal from the microprocessor.
17	CLK	Clock input terminal from the microprocessor.
18	VSS	Ground terminal.

LB1639 (Volume Motor Drive)

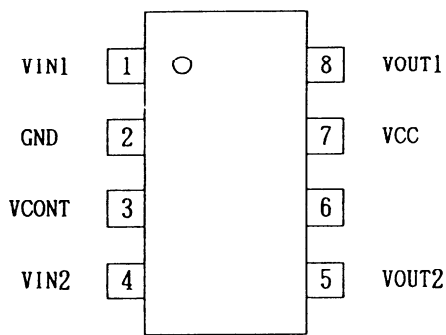

VIN1	VIN2	VOUT1	VOUT2	
H	L	H	L	CD
L	H	L	H	CCD
H	H	OFF	OFF	STOP
L	L	OFF	OFF	STOP

μPC1225H (Power Amplifier Driver)

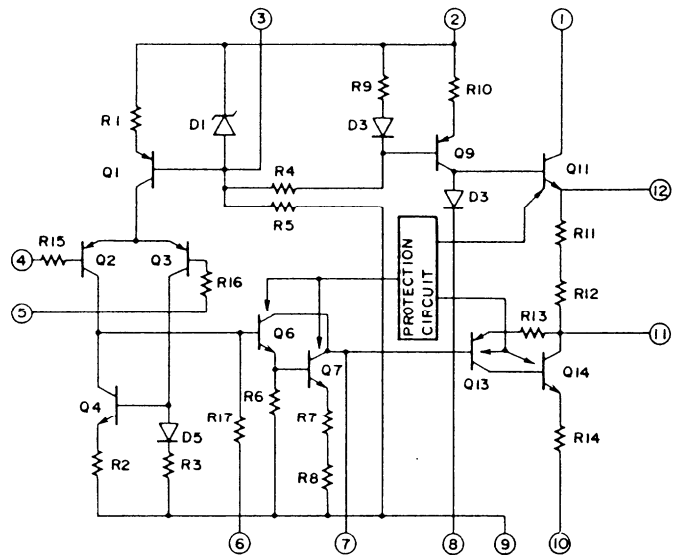

LA1266 (FM IF and AM Radio System)

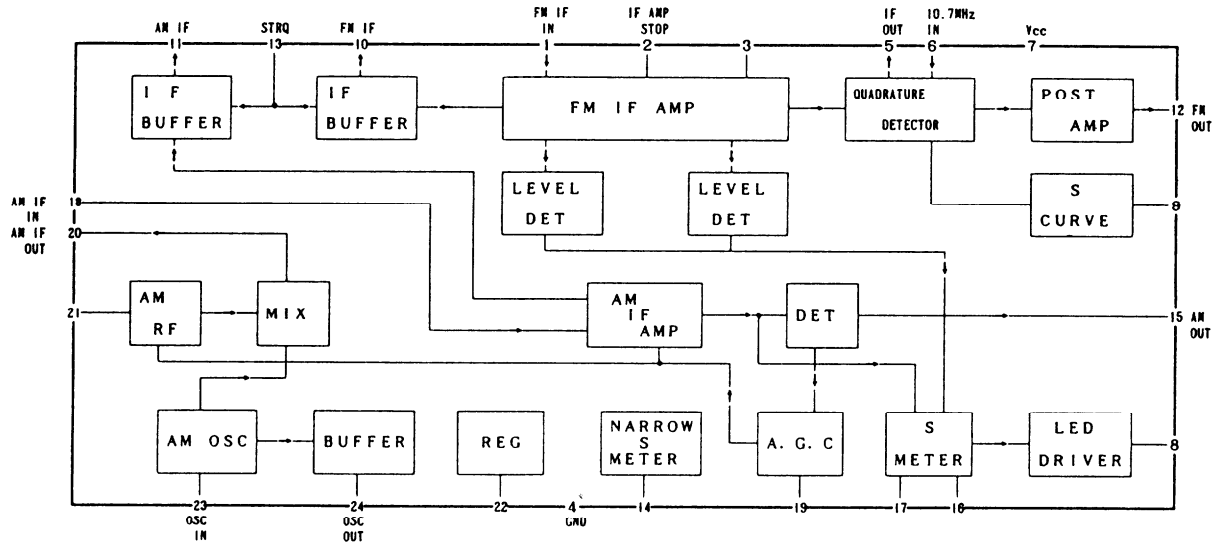

ADJUSTMENT PROCEDURES

Preparation

• Input

FM mono: 1kHz, 75kHz devi., 60dB/ μ V
 FM stereo: 1kHz, L+R 67.5kHz devi.: Pilot signal
 19kHz 7.5kHz devi.
 AM: 400Hz, 30% mod.,

• Output

Connect the non-inductive type resistor of 8 ohms to the speaker terminal A of left and right channels unless otherwise noted.

• Standard knob position

Input selector CD
 VOLUME Maximum
 BASS/TREBLE CENTER

Clock Frequency adjustment

Set the input selector switch to FM.

Set the tuning to 99.1 MHz.

Short between terminals + B and FADJ with the short clip, and connect the frequency counter to terminal F-OUT.

Adjust C756 so that the counter reading becomes $1,048,576 \pm 3\text{Hz}$. (NOTE:+B=+5V line)

After adjustment, disconnect the short clip and frequency counter.

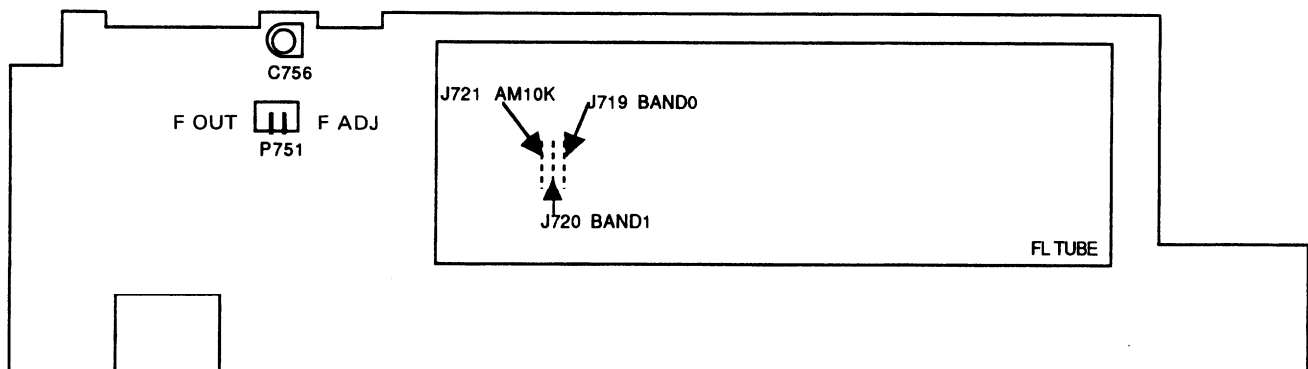

Step	Connection of instrument	FM SG output	Stereo modulator output	Turning dial setting	Output indicator	Adjustment	Adjust for	Remarks
1	Fig. 1	99.1MHz 1kHz, 75kHz devi. 65dB(60dB)	-	99.1 MHz	DC voltmeter	L101	0V ± 30mV	Mode switch: MONO Repeat the steps 1 and 2 until no further adjustment is necessary
2		99.1MHz 17.2dB(12dB) (120V model) 19.2dB(14dB) (Other models)	-	99.1 MHz	Distortion analyzer	R101	Minimum	Mode switch: AUTO Remove F102 when this adjustment can not.
1	Fig. 3	99.1MHz 16.2dB(11dB) (120V model) 18.2dB(14dB) (Other models)	-	99.1 MHz	Oscilloscope	R101	Output	Mode switch: AUTO Remove F102 when this adjustment can not.
2		98.00MHz 1kHz, 75kHz devi. 65dB(60dB)	-	98.00MHz	Frequency counter	R201	19kHz ± 10Hz	Mode switch: STEREO
1	Fig. 2	98.00MHz 1kHz, 75kHz devi. 65dB(60dB)	-	98.00MHz	Frequency counter	R201	19kHz ± 10Hz	Mode switch: STEREO
2		999kHz (990kHz) 400Hz, 30% mod. 60dB/m	999kHz (999kHz) 400Hz, 30% mod. 60dB/m	L or Rch. 1kHz	Distortion analyzer	IF on the front end	Minimum	Don't turn more than ±180°

AM SG output	Tuned frequency	Output indicator	Adjustment point	Adjust for
522kHz (530kHz)	522kHz (530kHz)	Digital DC voltmeter	OSC on RF block (L151)	1.3V ± 0.1V
603kHz (600kHz) 400Hz, 30% mod. 60dB/m	603kHz (603kHz)	AC voltmeter	RF on RF block (L151)	Maximum
999kHz (990kHz) 400Hz, 30% mod. 60dB/m	999kHz (999kHz)	AC voltmeter	L152	Maximum

() : 120V model

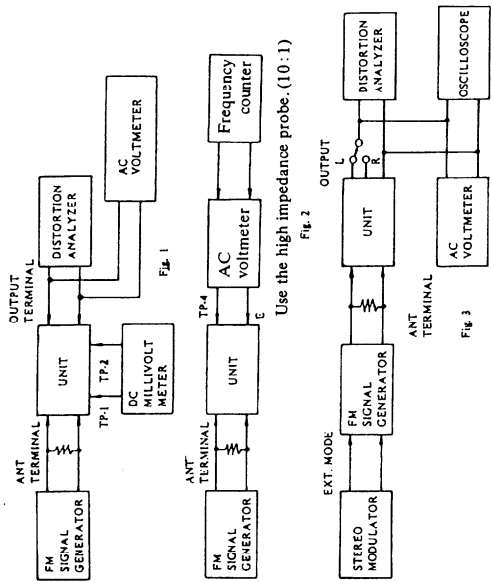
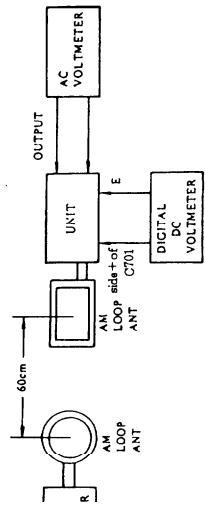

Reference specifications
 FM T uned voltages
 (Side + of C701 and ground)
 87.50MHz 1.6 ± 0.5V } 50kHz step models
 108.00MHz 8.0 ± 0.5V }
 87.9MHz 6 ± 0.5V }
 107.9MHz 8.0 ± 0.5V } 200kHz step models
 Auto stop level
 AM: Less than 68dB/m
 FM: Less than 18 dBz
 AM T uned voltage
 522kHz 1.3 ± 0.5V } 9kHz step models
 1611kHz 7.2 ± 0.5V }
 530kHz 1.3 ± 0.5V } 10kHz step models
 1710kHz 7.6 ± 0.5V }

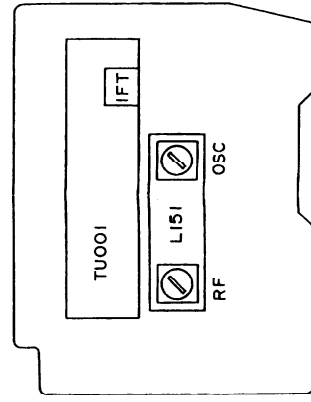

SCHEMATIC DIAGRAM

V MODEL -

A

B

C

D

E

F

G

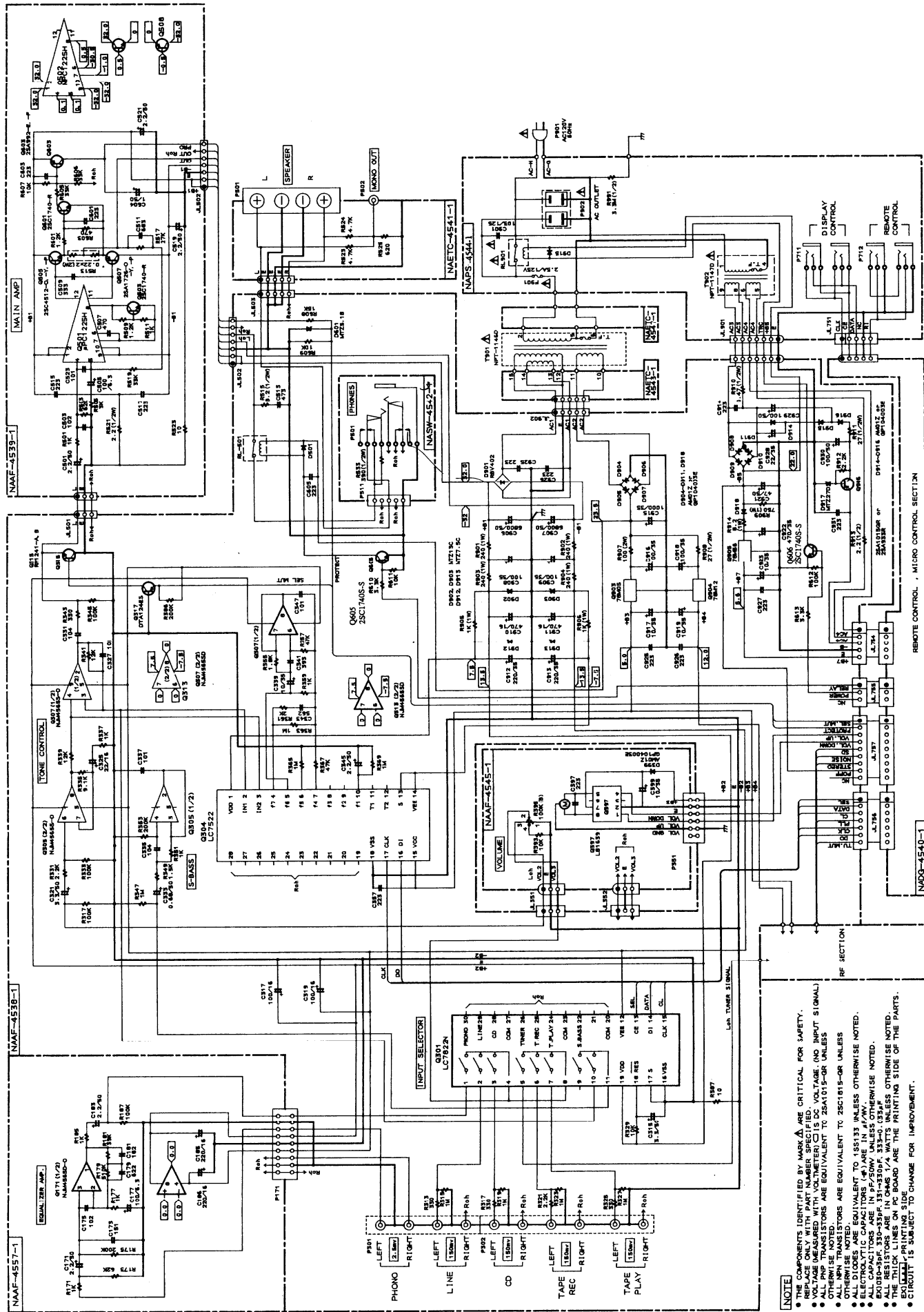

- NOTE**
- THE COMPONENTS IDENTIFIED BY MARK Δ ARE CRITICAL FOR SAFETY.
 - REPLACE ONLY WITH PART NUMBER SPECIFIED. Δ FOR TAPES AND INPUT SIGNAL.
 - ALL PNP TRANSISTORS ARE EQUIVALENT TO 2SA1015-OR UNLESS OTHERWISE NOTED.
 - ALL DIODES ARE EQUIVALENT TO 2SC1815-OR UNLESS OTHERWISE NOTED.
 - ELECTROLYTIC CAPACITORS (Φ) ARE IN μ F/V.
 - EXCEPT 330-330F, 150-150V, 150-150V UNLESS OTHERWISE NOTED.
 - ALL RESISTORS ARE IN OHMS 1/4 WATT UNLESS OTHERWISE NOTED.
 - THE THICK LINES ON PC BOARD ARE THE PRINTING SIDE OF THE PARTS.
 - CIRCUIT IS SUBJECT TO CHANGE FOR IMPROVEMENT.

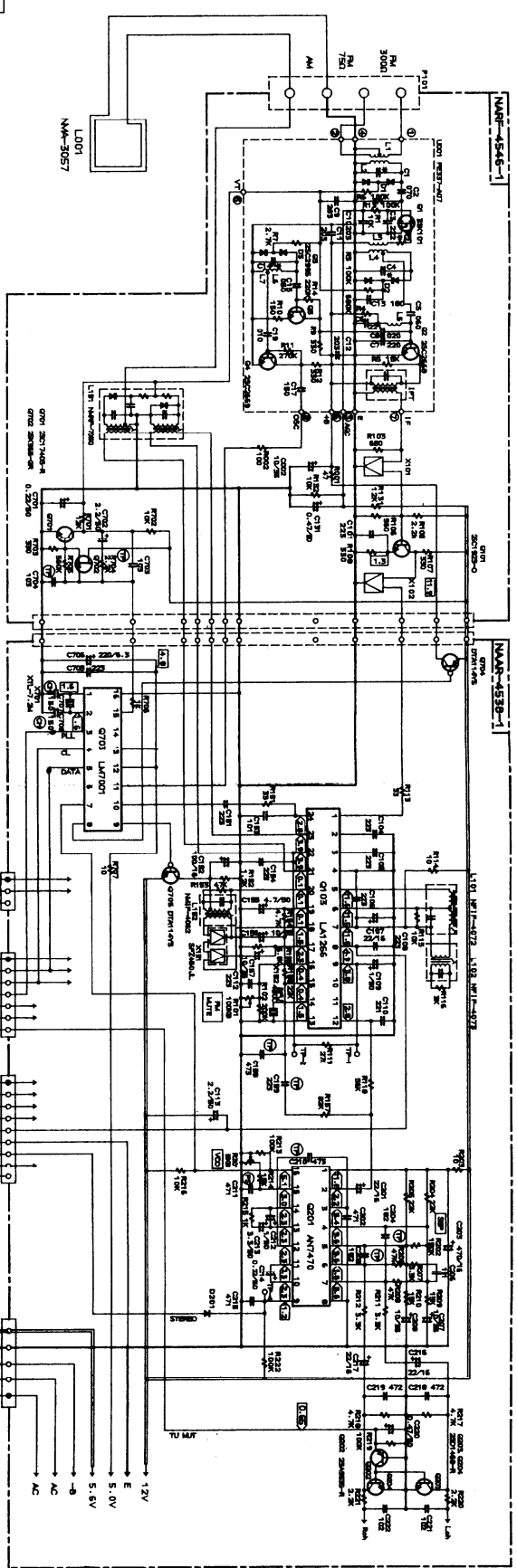

NOTE

- THE COMPONENTS IDENTIFIED BY MARK Δ ARE CRITICAL FOR SAFETY.
- RESISTORS ARE SHOWN WITH TOLERANCE. RESISTOR VALUES IN Ω, K, M, OR VOLTAGE (NO INPUT SIGNAL).
- ALL PNP TRANSISTORS ARE EQUIVALENT TO 2SA1015-Q98 UNLESS OTHERWISE NOTED.
- ALL DIODES ARE EQUIVALENT TO 1SS133 UNLESS OTHERWISE NOTED.
- ELECTROLYTIC CAPACITORS (CAP) ARE IN μF/MV.
- ALL RESISTORS ARE IN Ω UNLESS OTHERWISE NOTED.
- ALL RESISTORS ARE IN OHMS 1/4 WATT UNLESS OTHERWISE NOTED.
- FOR TYPICAL PRINTING SIDE OF THE PRINTING BOARD.
- CIRCUIT IS SUBJECT TO CHANGE FOR IMPROVEMENT.

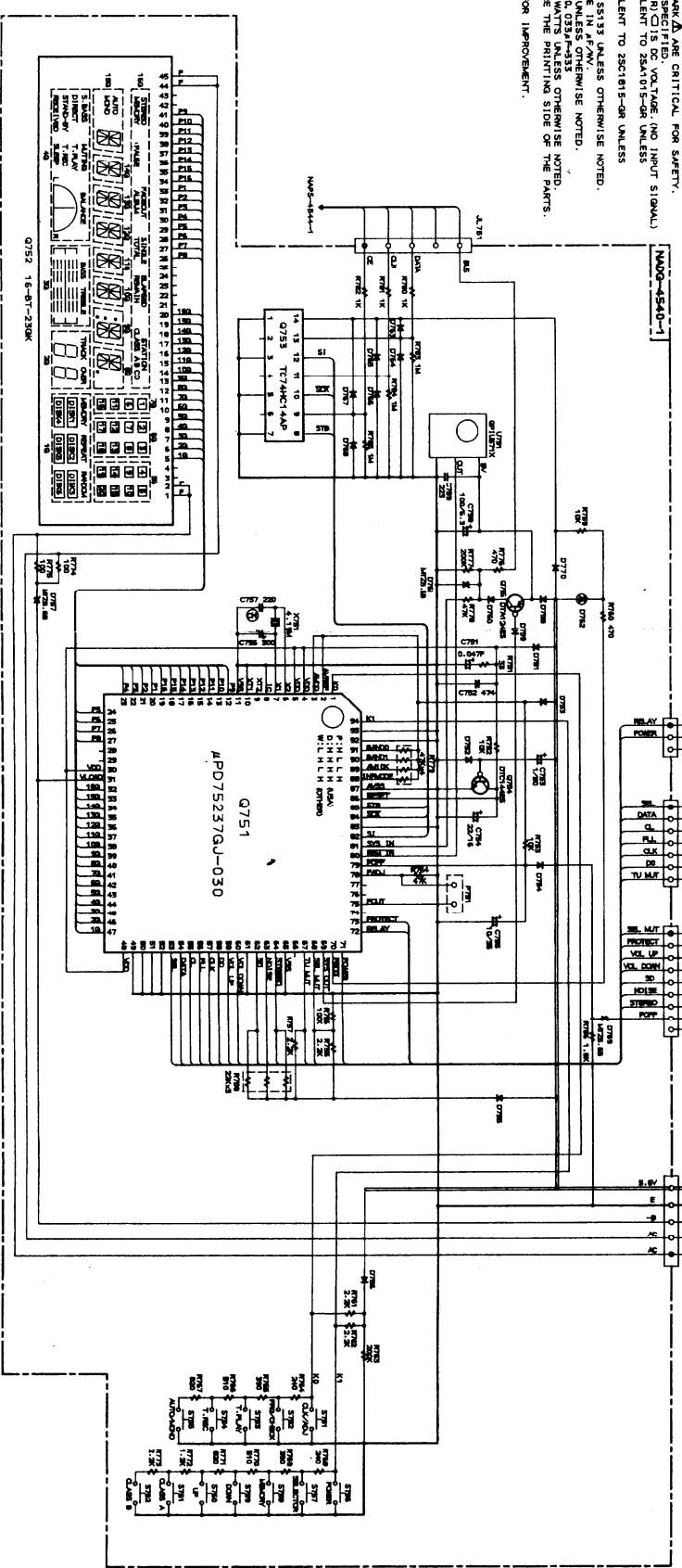

PRINTED CIRCUIT BOARD PARTS LIST

MAIN CIRCUIT PC BOARD(NAAR-4538-1/1A/1B)

CIRCUIT NO.	PART NO.	DESCRIPTION	CIRCUIT NO.	PART NO.	DESCRIPTION
			C211	370134714	470pF±5%,100V,Plastic
Q103	22240039	LA1266	C213,C315	354780339	3.3 μ F,50V,Elect.
Q201	22240242	AN7470	C214	354782299	0.22 μ F,50V,Elect.
Q301	22240270	LC7822N	C216,C217	354742209	22 μ F,16V,Elect.
Q304	22240219	LC7522	C220	354784799	0.47 μ F,50V,Elect.
Q305-Q308	22240273	NJM4565S-D	C317,C319	354741019	100 μ F,16V,Elect.
Q703	22240090	LM7001	C321,C322	354780339	3.3 μ F,50V,Elect.
Q903	222780055	78M05HF	C325,C326	354742209	22 μ F,16V,Elect.
Q904	222780125	78M12HF	C331,C332	374721044	0.1 μ F±5%,50V,Plastic
Q905	222780565JRC	78M56	C333,C334	354786899	0.68 μ F,50V,Elect.
	Transistors		C335,C336	374721044	0.1 μ F±5%,50V,Plastic
Q102	2210746	2SC945A-P <P/W/Q>	C339,C340	354761009	10 μ F,35V,Elect.
Q202	2213354	2SA933S-R	C341,C342	374723934	0.039 μ F±5%,50V,Plastic
Q203,Q204	2212794	2SD1468-R	C343,C344	374725624	5600pF±5%,50V,Plastic
Q315,Q316	2213631 or	RN1241-A or	C345,C346	354780229	2.2 μ F,50V,Elect.
	2213632	RN1241-B	C513,C514	374724734	0.047 μ F±5%,50V,Plastic
Q317	2212600	DTA124ES	C706	354722219	220 μ F,6.3V,Elect.
Q605,Q606	2213285	2SC1740S-S	C906,C907	3504207	6800 μ F,50V,Elect.
Q704,Q705	2213090	DTA114YS	C908,C909	354761019	100 μ F,35V,Elect.
Q906	2213354	2SA933S-R	C910,C911	354744719	470 μ F,16V,Elect.
	Diodes		C912,C913	354742219	220 μ F,16V,Elect.
D201,D501	223163	1SS133	C915	354761029	1000 μ F,35V,Elect.
D601	224450512	MTZ5.1B	C916,C918	354761019	100 μ F,35V,Elect.
D901	22380022	RRV402	C917,C919	354761009	10 μ F,35V,Elect.
D902,D903	224451303	MTZ13C	C921	354784709	47 μ F,50V,Elect.
D904-D911	22380046 or	AM01Z or	C922	354764719	470 μ F,35V,Elect.
D914-D916	22380035	GP104003E	C923	354761009	10 μ F,35V,Elect.
D912,D913	224450753	MTZ7.5C	C928	354762209	22 μ F,35V,Elect.
D917	224452704	MTD27D	C929,C930	354781019	100 μ F,50V,Elect.
D918	22380046 or	AM01Z or		Resistors	
	22380035	GP104003E	R101	5210070 or	N06HR100KBD,
	Coils and Transformers			5210221	Semi-fixed
L101	233401	NMIF-4072	R201	5210062 or	N06HR4.7KBD or
L102	233402	NMIF-4073		5210216	N06HR5KBD,Semi-fixed
L103	233383	NMC-6070 <P/W/Q>	R515,R516	442520824	8.2 Ω ±5%,1/2W,Metal oxide film
L152	232139	NMIF-4062	R901-R904	441622414	240 Ω ±5%,1W,Metal oxide film
L201,L202	233355A	NMC-4059 <P/W/Q>	R905,R906	441621024	1k Ω ±5%,1W,Metal oxide film
	Relay			Resistors	
RL501	25065339	NRL-2P5A-DC24-046	R907	441721014	100 Ω ±5%,2W,Metal oxide film
	Ceramic filters,		R908,R911	442522704	27 Ω ±5%,1/2W,Metal oxide film
X103	3010137	SFE10.7MMK <P/W/Q>	R909	441627514	750 Ω ±5%,1W,Metal oxide film
X151	3010123	SFZ450JL	R910	442524794	0.47 Ω ±5%,1/2W,Metal oxide film
X152	3010076	BFU450C	R913	442520224	2.2 Ω ±5%,1/2W,Metal oxide film
	X'ial		R914	441620824	8.2 Ω ±5%,1W,Metal oxide film
X701	3010141 or	XTL7.2M		Terminals	
	3010158		P301	25045303	NPJ-4PDBL162
	Capacitors		P302	25045300	NPJ-6PDBL159
C107,C201	354742209	22 μ F,16V,Elect.		Sockets	
C109,C212	354780109	1 μ F,50V,Elect.	JL351a,JL352a	25050267	NSCT-3P95
	Capacitors		JL754a	25050527	NSCT-5P350
C113	354780229	2.2 μ F,50V,Elect.	JL755a	25050525	NSCT-3P348
C152	354741019	100 μ F,16V,Elect.	JL756a	25050529	NSCT-7P352
C155	354780479	4.7 μ F,50V,Elect.	JL757a	25050531	NSCT-9P354
C156,C157	354761009	10 μ F,35V,Elect.		Plugs	
C158	374724734	0.047 μ F±5%,50V,Plastic	P111a,P112a	25055258	NPLG-6P241
C159	374722234	0.022 μ F±5%,50V,Plastic	P351a	25055497	NPLG-6P472
C203	354744719	470 μ F,16V,Elect.		25055038	NPLG-2P29
C204,C205	374721824	1800pF±5%,50V,Plastic <D>		25055042	NPLG-3P32
	374721224	1200pF±5%,50V,Plastic <P/Q>		Switch	
	374721524	1500pF±5%,50V,Plastic <W>	S701	25065414	NSS-22155 <W>
C207,C208	354761009	10 μ F,35V,Elect.			
C210	374724734	0.047 μ F±5%,50V,Plastic			

CAUTION: Replacement for transistor of mark *, if necessary, must be made from the same beta group (H FE) as the original type.

MAIN AMPLIFIER CIRCUIT PC BOARD(NAAF-4539-1)

CIRCUIT NO.	PART NO.	DESCRIPTION
ICs		
Q501,Q502	22240108	μ PC1225H
Transistors		
Q503,Q504	2213284	2SC1740S-R
Q505,Q506	2202303,	☆ 2SC4512-O,
	2202304 or	☆ 2SC4512-Y or
	2202305	☆ 2SC4512-P
Q507,Q508	2202313,	☆ 2SA1726-O,
	2202314 or	☆ 2SA1726-Y or
	2202315	☆ 2SA1726-P
Q601,Q602	2213284	2SC1740S-R
Q603	2211792 or	2SA992-F or
	2211793	2SA992-E
Capacitors		
C501,C502	354780229	2.2 μ F,50V,Elect.
C505,C506	354721019	100 μ F,6.3V,Elect.
C509,C510	374723334	0.033 μ F \pm 5%,50V,Plastic
C511,C512	374726834	0.068 μ F \pm 5%,50V,Plastic
C519,C521	354780229	2.2 μ F,50V,Elect.
C604	354780109	1 μ F,50V,Elect.
Resistors		
R513,R514	45000131	0.22 Ω \pm 5%,Metal plate
R521	442520224	2.2 Ω \pm 5%,1/2W,Metal oxide film

MICROPROCESSOR CIRCUIT PC BOARD(NADG-4540-1/1A/1B)

CIRCUIT NO.	PART NO.	DESCRIPTION
Opto. receivng module		
U751	24130007	GP1U571X
FL tube		
Q752	212114	16-BT-23GK
ICs		
Q751	22240633Y	μ PD75237GL-030
Q753	222740145TOS	TC74HC14AP
Transistors		
Q754	221282	DTC144ES
Q755	2212600	DTA124ES
Diodes		
D751-D756	223163	1SS133
D757,D761	224450562	MTZ5.6B
D758-D760	223163	1SS133
D762	225141	SEL2213C
D763-D768	223163	1SS133
D769	224450562	MTZ5.6B
D770	223163	1SS133
X'tal		
X751	3010121A	XTL-4.19M
Capacitors		
C751	3000060	0.047F,5.5V,Super
C752	375524744	0.47 μ F \pm 5%,50V,Plastic
C753	354780109	1 μ F,50V,Elect.
C754	354742209	22 μ F,16V,Elect.
C755	354761009	10 μ F,35V,Elect.
C756	3060029	NTC-30P25,Trimmer
C758	354721019	100 μ F,6.3V,Elect.
Resistors		
R758	49163223403	22k Ω \times 3,1/10W,Array
R779	49163473404	47k Ω \times 4,1/10W,Array
Switches		
S751-S762	25035548	NPS-111-S510

CIRCUIT NO.	PART NO.	DESCRIPTION
Plug		
P751	25055495	NPLG-2P470
Holders		
	27190893Y	FL
	27190811Y	LED
Bracket		
	27141575	RI

SPEAKER TERMINAL PC BOARD(NAETC-4541-1/1A)

CIRCUIT NO.	PART NO.	DESCRIPTION
P501	25060116	NTM-4PDMLO50,Terminal,speaker
P502	25045302	NPJ-1PDBL161,Terminal,MONO OUT

HEADPHONE TERMINAL PC BOARD(NASW-4542-1)

CIRCUIT NO.	PART NO.	DESCRIPTION
R533,R534	442523914	390 Ω \pm 5%,1/2W,Metal oxide film resistor
P501	25045372	LGS6517-0202,Headphone terminal
P511	25055319	NPLG-5P302,Plug

POWER SUPPLY CIRCUIT PC BOARD(NAPS-4544-1/1A/1B/1C)

CIRCUIT NO.	PART NO.	DESCRIPTION
C901	3500065A	▲ DE7150FZ103PAC400V/125V,IS capacitor
C901a	27301216	▲ SB1925A,Cover,capacitor <P/W/Q>
D915	223163	1SS133,Diode
F901	252149	▲ 2.5A-TSC,Primary fuse <D/W>
	252071	▲ 1.25A-SE-EAK,Primary fuse <P/Q>
F901a	25050065	▲ YSH-403T,Fuseholder
F901b	29360626-1Y	Rating label,fuse <D>
	29360606	Rating label,fuse <P/W/Q>
F902	252071	▲ 1.25A-SE-EAK,Primary fuse <P/W>
F902a	25050065	▲ YSH-403T,Fuseholder <P/W>
JL751a	25050527	NSCT-5P350,Socket
JL901a	25050271	NSCT-7P99,Socket
P711	25045330	HSJ-2PDBL184,Terminal RI
P712	25045370	HSJ-2PDGR213,Terminal,CD display
P901	25050409	▲ NSCT-4P234,AC outlet <D>
R991	431523355	▲ 3.3M Ω ,1/2W,Solid resistor <D>
RL901	25065357Y	▲ NRL-1P5A-DC24-051,Relay <D>
	25065341Y	▲ NRL-1P15A-DC24-047,Relay <P/W/Q>
T902	2300816Y	▲ NPT-1147D,Power transformer <D>
	2300817Y	▲ NPT-1147P,Power transformer <P>
	2300818Y	▲ NPT-1147DG,Power transformer <W>
	2300819Y	▲ NPT-1147Q,Power transformer <Q>

VOLUME CIRCUIT PC BOARD(NAAF-4545-1)

CIRCUIT NO.	PART NO.	DESCRIPTION
Q399	22240322	LB1639,IC
D399	22380046 or	AM01Z or
	22380035	GP104003E,Diode
C399	354761009	10 μ F,35V,Elect. capacitor
R395	5142009Y	N16RGM100KBT20F,Variable resistor
P351	25050444	NSCT-6P268,Socket

FRONT END CIRCUIT PC BOARD(NARF-4546-1/1A)

CIRCUIT NO.	PART NO.	DESCRIPTION
U001	240088	FE337-A07,Front end <D>
	240089	FE415-G11,Front end <P/W/Q>
Q101	2211723	2SC1923-O,Transistor
Q131	2213284	2SC1740S-R,Transistor <P/W/Q>
Q701	2213284	2SC1740S-R,Transistor
Q702	2212445	2SK365-GR,F.E.T

CIRCUIT NO.	PART NO.	DESCRIPTION
D131,D132	223132	1K60,Diode <P/W/Q>
L151	232148	NMRF-7050,RF block
X101,X102	3010071	SFE10.7MA5,Ceramic filter <D>
	3010137	SFE10.7MMK,Ceramic filter <P/W/Q>
C002	354761009	10 μ F,35V,Elect. capacitor
C131	354784799	0.47 μ F,50V,Elect. capacitor
C132	354742209	22 μ F,16V,Elect. capacitor <P/W/Q>
C701	354782299	0.22 μ F,50V,Elect. capacitor
C702	354780229	2.2 μ F,50V,Elect. capacitor
C703,C704	374721034	0.01 μ F \pm 5%,50V,Plastic capacitor
C704	374721034	0.01 μ F \pm 5%,50V,Plastic capacitor
P101	25060160	NTM-4PDML086,Antenna terminal <D>
	25060117	NTM-2PDML051,Antenna terminal <P/W/Q>
P111,P112	25050302	NSCT-6P129,Socket

EQUALIZER AMPLIFIER PC BOARD(NAAF-4557-1)

CIRCUIT NO.	PART NO.	DESCRIPTION
	IC	
Q171	22240191	NJM4565D-D
	Capacitors	
C171,C172	354780229	2.2 μ F,50V,Elect.
C177,C178	354721019	100 μ F,6.3V,Elect.
C179,C180	374726224	6200pF \pm 5%,50V,Plastic
C181,C182	374721824	1800pF \pm 5%,50V,Plastic
C183,C184	354780229	2.2 μ F,50V,Elect.
C185,C186	354742219	220 μ F,16V,Elect.
	Plug	
P171	25055334	NPLG-9P317

NOTE: <D>: Only 120V model
 <P>: Only 230V model
 <W>: Only Worldwide model
 <Q>: Only 240V model

NOTE:
 THE COMPONENTS IDENTIFIED BY MARK Δ ARE CRITICAL
 FOR RISK OF FIRE AND ELECTRIC SHOCK. REPLACE ONLY
 WITH PART NUMBER SPECIFIED.

PACKING VIEW

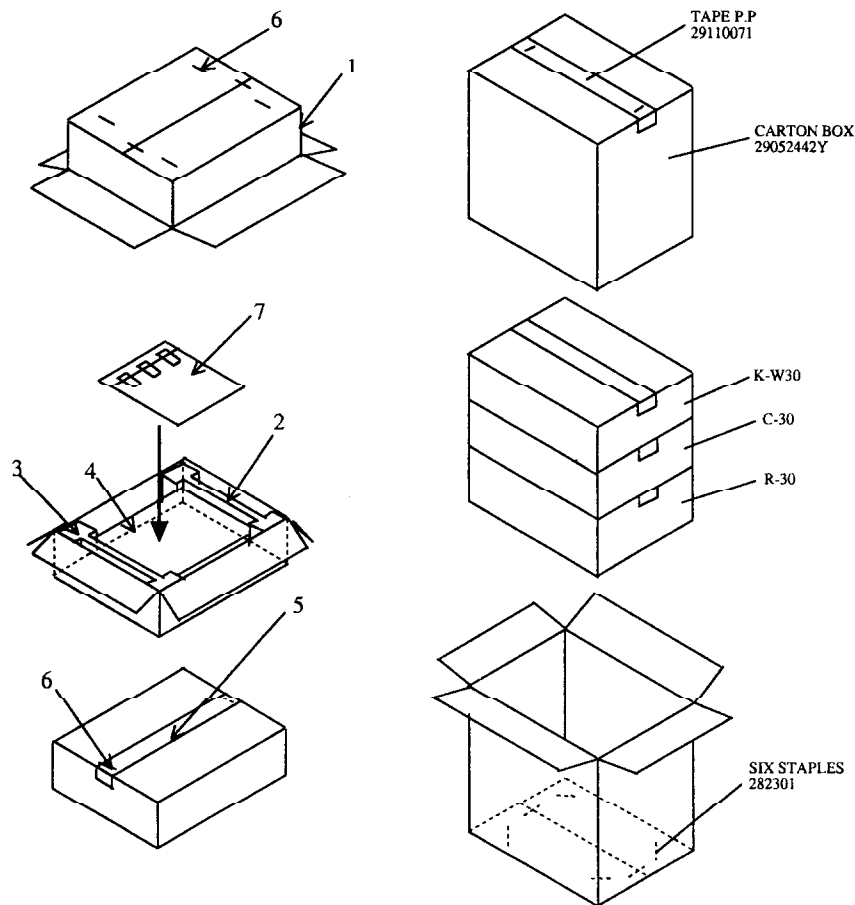

NOTE: <D>: 120V model only
 <P>: 230V model only
 <W>: Worldwide model only
 <Q>: 240V model only
 <F>: French model only
 <S>: Silver model only
 : Black model only

REF.NO.	PART NO.	DESCRIPTION	REF.NO.	PART NO.	DESCRIPTION
1	29052423AY	Master carton box <S>	292112	292112	FM antenna <P/W/Q>
	29052424AY	Master carton box 	232140	232140	NMA-3057, AM loop antenna
2	29091576Y	Pad F	24140229Y	24140229Y	RC-229S, Remote control transmitter
3	29091577Y	Pad R	3010194Y	3010194Y	Two batteries
4	29100037A	Styrene bag	29341747AY	29341747AY	Instruction manual
5	29110071	PP tape	29341748AY	29341748AY	Instruction manual <P/W>
6	282301	Sealing hook	29341749AY	29341749AY	Instruction manual <P/W>
7	Accessory bag ass'y		28341785	28341785	Instruction sheet
	2010098A	Three connection cords	25065448	25065448	YAE21-0235, FM antenna adaptor <F/W/Q>
	2010221	Three cords RI	29100097	29100097	Styrene bag
	292111	FM antenna <D>	25053018	25053018	CV-K-1, Conversion plug <W>

ONKYO CORPORATION

International Division: Onarimon Yusen Bldg., 23-5,
 Nishi-Shimbashi 3-chome, Minato-ku, TOKYO 105, JAPAN
 Tel: 03-3432-6987 Fax: 03-3436-6979

ONKYO U.S.A. CORPORATION

200 Williams Drive, Ramsey, N.J. 07446, U.S.A.
 Tel: 201-825-7950 Fax: 201-825-8150

ONKYO EUROPE

Immeuble Le Diamant, Domaine Technologique de Saclay, 4 Rue René Razel,
 91892 SACLAY, FRANCE Tel: (1) 69 33 14 15 Fax: (1) 69 41 29 66

ONKYO FRANCE

Immeuble Le Diamant, Domaine Technologique de Saclay, 4 Rue René Razel,
 91892 SACLAY, FRANCE Tel: (1) 69 33 14 00 Fax: (1) 69 41 35 84

ONKYO DEUTSCHLAND GMBH ELECTRONICS

Industriestrasse 20, W-8034 Germering, GERMANY
 Tel: 089 84 93 20 Fax: 089 84 93 226 TLX: 05-21726 ONKY D