

# ONKYO SERVICE MANUAL

## POWERED SUBWOOFER MODEL SKW-100

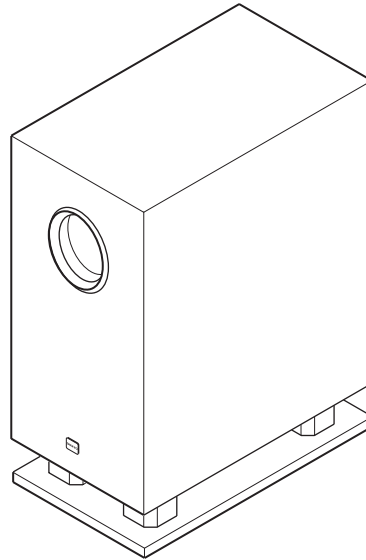

### Black models

DD	120V AC, 60Hz
----	---------------

### SAFETY-RELATED COMPONENT WARNING!!

COMPONENTS IDENTIFIED BY MARK  ON THE SCHEMATIC DIAGRAM AND IN THE PARTS LIST ARE CRITICAL FOR RISK OF FIRE AND ELECTRIC SHOCK. REPLACE THESE COMPONENTS WITH ONKYO PARTS WHOSE PART NUMBERS APPEAR AS SHOWN IN THIS MANUAL.

MAKE LEAKAGE-CURRENT OR RESISTANCE MEASUREMENTS TO DETERMINE THAT EXPOSED PARTS ARE ACCEPTABLY INSULATED FROM THE SUPPLY CIRCUIT BEFORE RETURNING THE APPLIANCE TO THE CUSTOMER.

# ONKYO®

IMAGINATIVE SIGHT & SOUND

## SPECIFICATION

Type	Bass-reflex with built-in power amplifier
Frequency response	30 Hz-150 Hz
Output power	150 W Dynamic
Input sensitivity	220 mV
Input impedance	15 kΩ
Woofers	8 inch cone type
Power supply	AC120V, 60Hz
Power consumption	75 W
Dimensions (WxHxD)	9-1/4" x 20-5/16" x 16-3/16" / 235 x 516 x 411 mm
Weight	29.1 lbs. / 13.2 kg

Specifications and appearance may subject to change for improvement without prior notice.

## SERVICE PROCEDURES

### 1. Replacing the fuse

 This symbol located near the fuses indicates that the fuse used is fast operating type. For continued protection against fire hazard, replace with same type fuse. For fuse rating refer to the marking adjacent to the symbol.

 Ce symbole indique que le fusible utilise est a rapide. Pour une protection permanente, n'utiliser que fusibles de meme type. Ce dernier est la qu le present symbol est appse.

CIRCUIT NO.	PART NO.	DESCRIPTION
F902,903	HWF1180406100	T4AL/250V, Fuse

A

B

C

D

EXPLODED VIEW

1

2

3

4

5

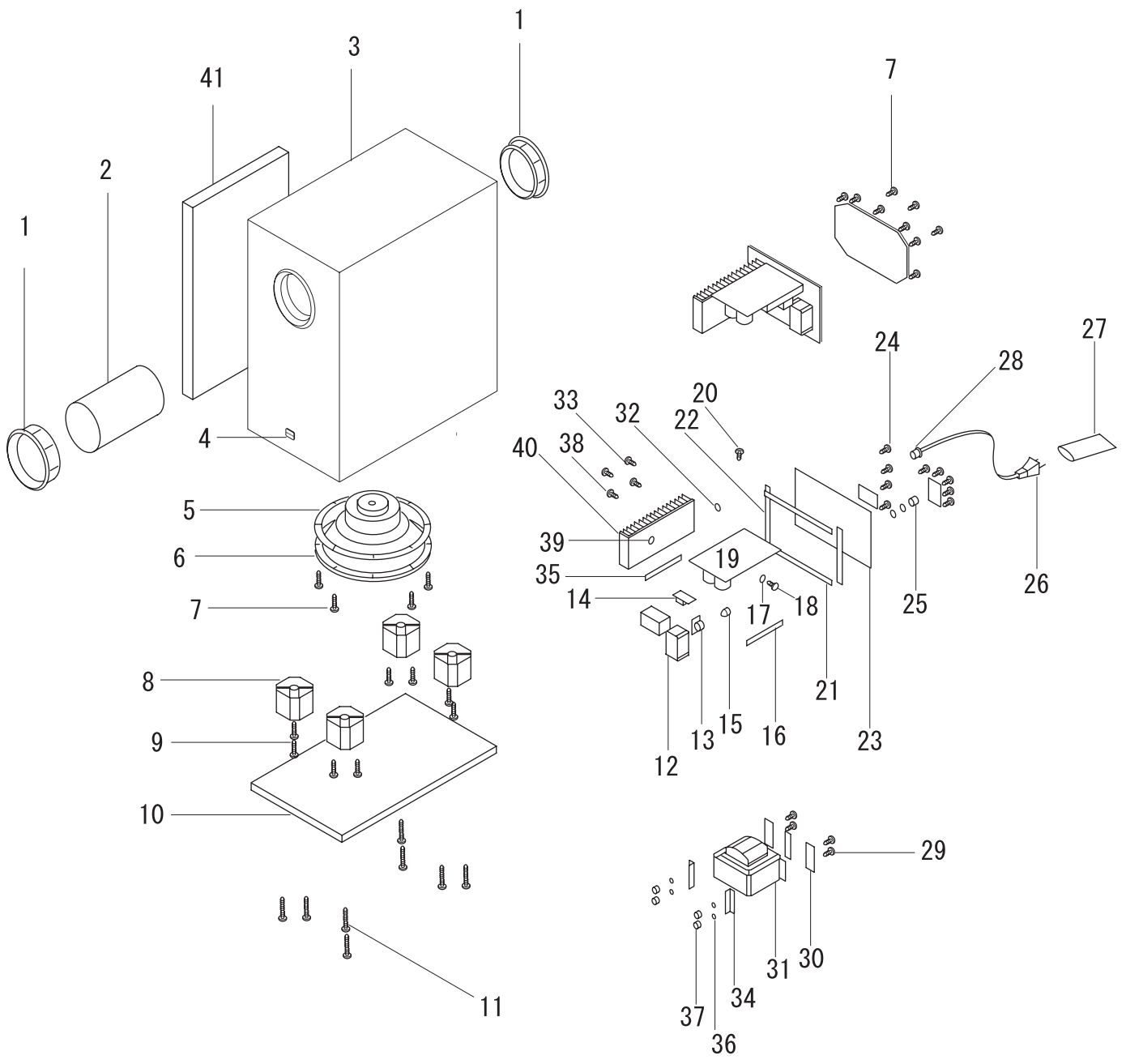

**A**                      **B**                      **C**                      **D**

# SCHEMATIC DIAGRAM

1  
2  
3  
4  
5

**U1** MAIN PC BOARD (LVM0199C011)

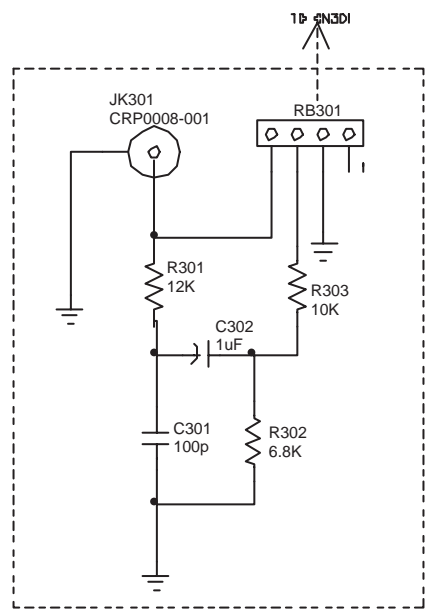
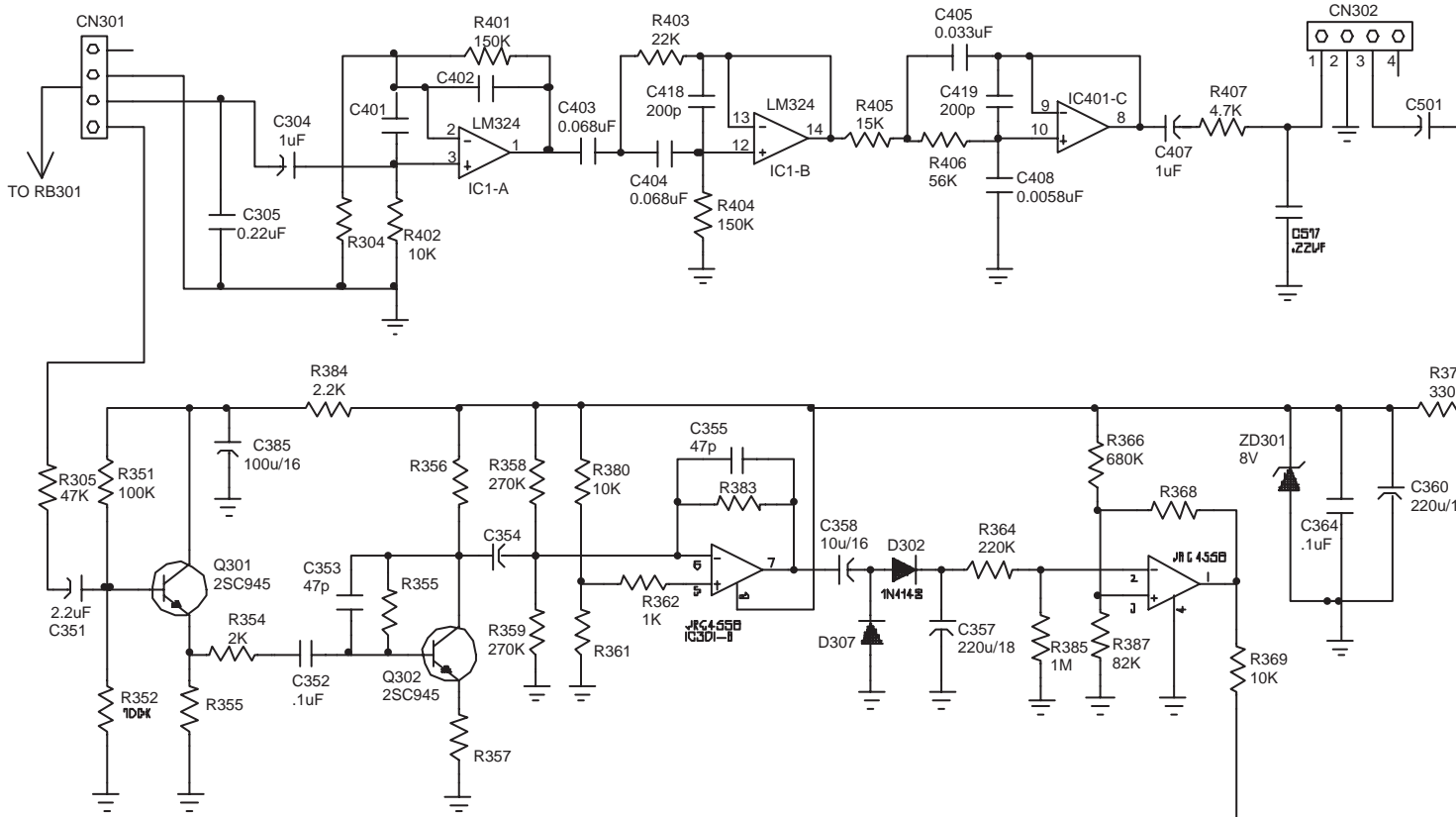

**U3** JACK PC BOARD (LVM0199C21)

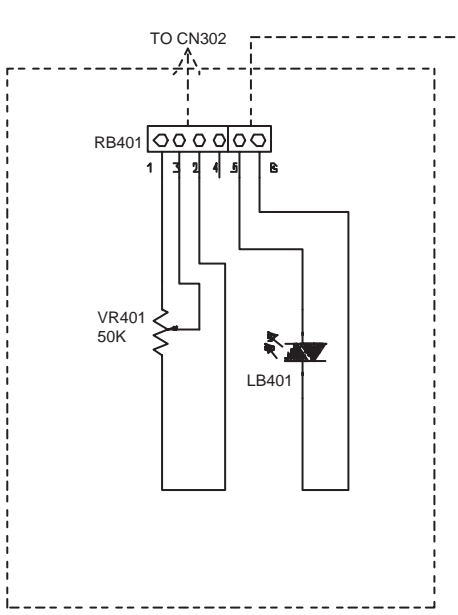

**U2** VOLUME PC BOARD (LVA0222C001)

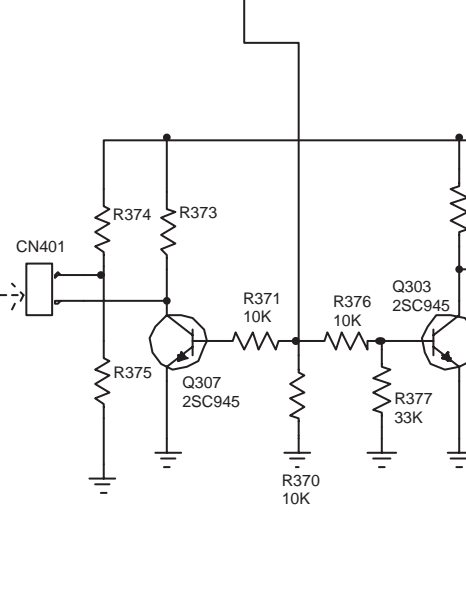

E

F

G

H

TO RB401

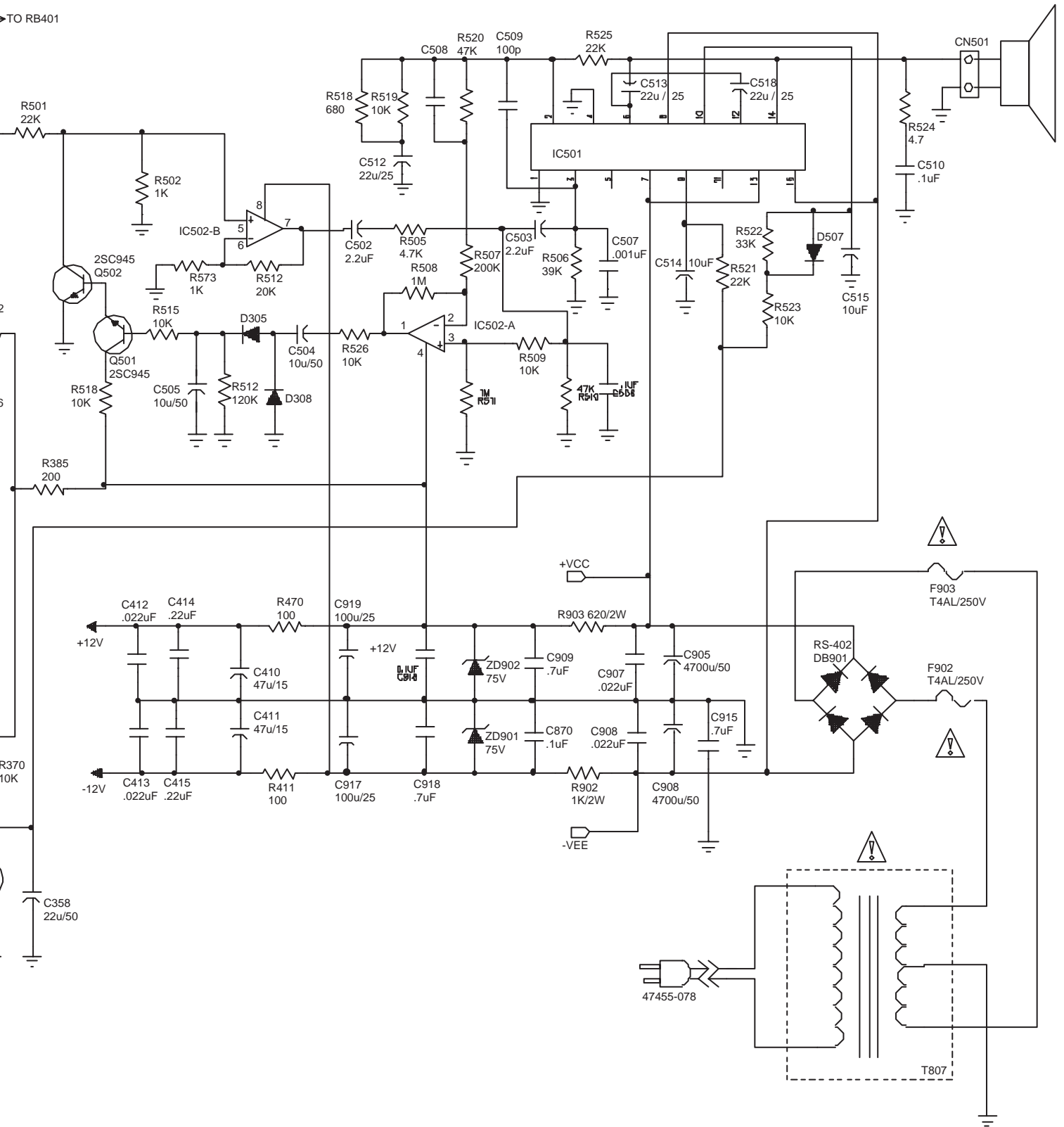

SCHEMATIC DIAGRAM

U1 MAIN PC BOARD (LVM0199C011)

1  
2  
3  
4  
5

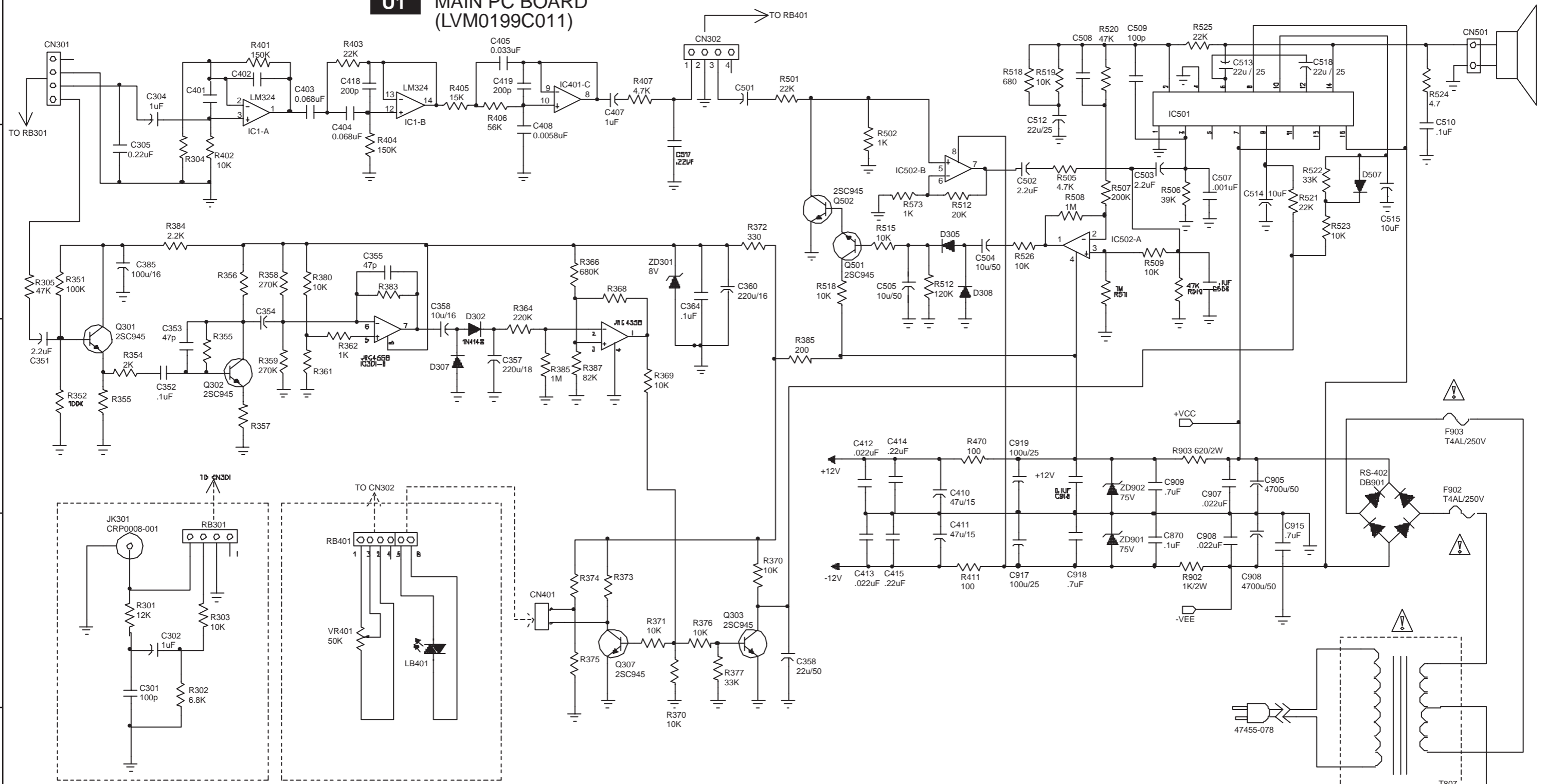

U3 JACK PC BOARD (LVM0199C21)

U2 VOLUME PC BOARD (LVA0222C001)

A

B

C

D

PRINT CIRCUIT BOARD VIEW

**U1** MAIN PC BOARD (LVM0199C011)

1

2

3

4

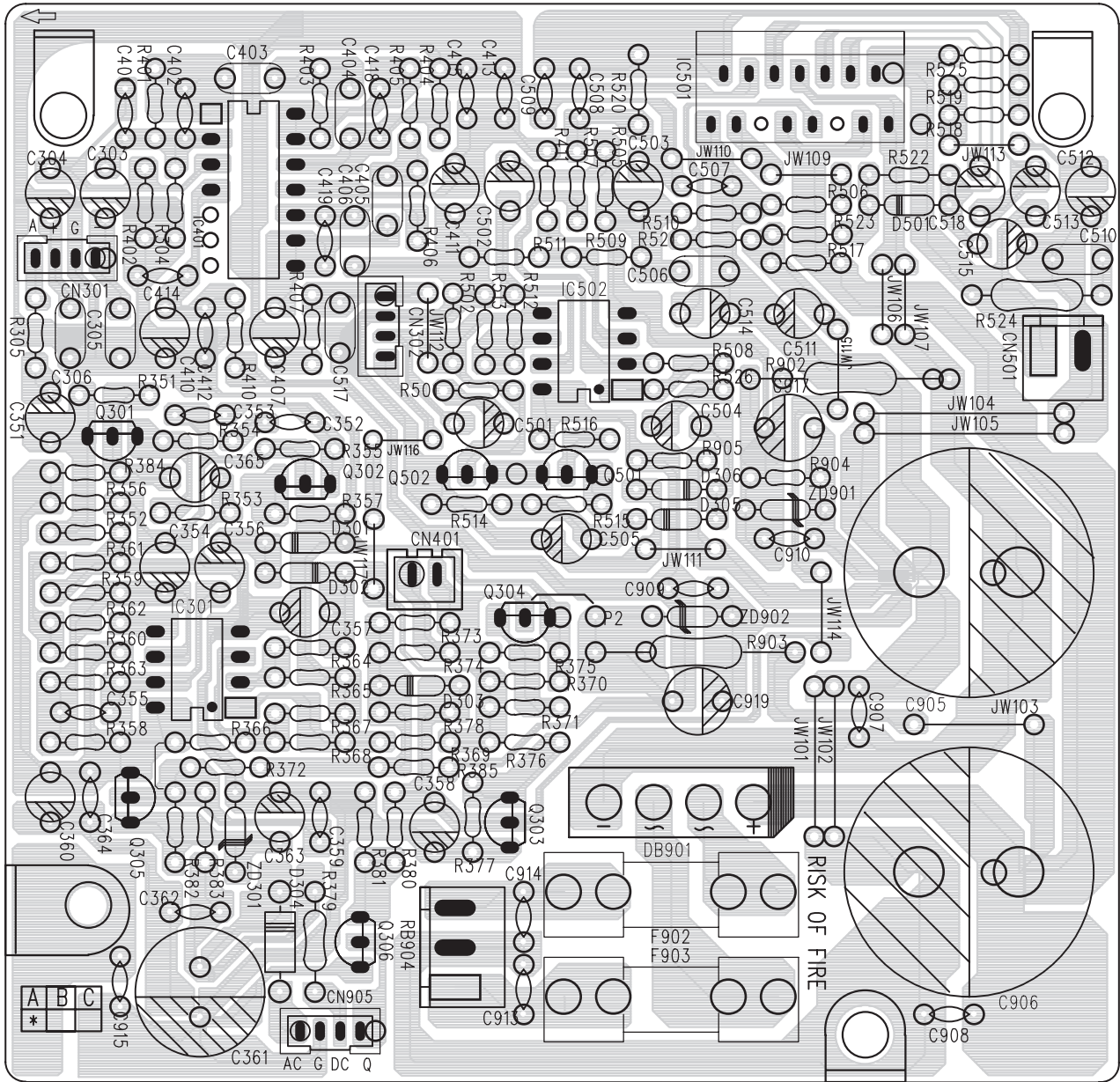

**U2** VOLUME PC BOARD (LVM0199C021)

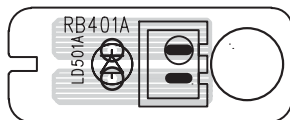

**U3** JACK PC BOARD (LVA0222C001)

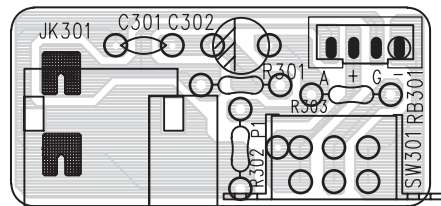

5

**SKW-100**

Ref. No.	Part No	Description
1	BPR0018C001	Pote tube
2	DPP9630-158	Paper duct
3	EVM056C001	Wood box
4		Logo
5	IVE0037-001	Sponge
6	FSWA080-312	SPK driver
7	H011109-316	Screw
8	BPE0007C001	Foot
9	H011708-325	Screw
10	EVB0001C001	Wood board
11	H011708-370	Screw
12	BPC0021-001	Rear cover
13	APE0222C001	VR/LED ass'y
14	APE0199CC23	Jack ass'y
15	DLH0014-002	LED holder
16	GSE0117C001	PCB BKT
17	DSS0007-002	Washer
18	H121003-310	Screw
19	APE0199CD13	PCB ass'y
20	H121009-308	Screw
21	IVE0183C001	Sponge
22	IVE0182C001	Sponge
23	GSP0047C001	Rear plate
24	H121009-312	Screw
25	BPK5018-003	Volume knob
26	47455-D65	Line cord
27	IVP0001-003	Polybag
28	DBU3050-110	Bushing
29	H110504-325	Screw
30	ICU0007-001	Rubber pad
31	TT11201C012	PWR trans
32	HWF8040-010	Washer FIB
33	H110303-308	Screw
34	GSE0110-001	Bracket
35	GSE0206-001	PCB bracket
36	HWT8540-110	Washer
37	HNM4070-130	Nut
38	H110303-314	Screw
39	GSE0093-002	PCB bracket
40	GAL0044C002	Heat sink
	<b>2210746</b>	<b>2SC945</b>
	<b>RHI4558-001</b>	<b>JRC4558D</b>
	<b>RHI0324-001</b>	<b>LM324N (14 PIN)</b>
	<b>RHI7293-001</b>	<b>TDA7293 (15 PIN)</b>
41		Sound absorber



---

**ONKYO CORPORATION**

Sales & Product Planning Div. : 2-1, Nisshin-cho, Neyagawa-shi, OSAKA 572-8540, JAPAN  
Tel: 072-831-8111 Fax: 072-833-5222

**ONKYO U.S.A. CORPORATION**

18 Park Way, Upper Saddle River, N.J. 07458, U.S.A.  
Tel: 201-785-2600 Fax: 201-785-2650 E-mail: onkyo@onkyousa.com

