

# ONKYO SERVICE MANUAL

## POWERED SUBWOOFER MODEL SKW-204(B)/(S)/(Y)



Black, Silver and Yellow models

B MDC	120V AC, 60Hz	S MPA	230-240V AC, 50Hz
B MPP	230-240V AC, 50Hz	S MWT	120/220-240V AC, 50/60Hz
S MPP	230-240V AC, 50Hz	Y MWT	120/220-240V AC, 50/60Hz

### SAFETY-RELATED COMPONENT WARNING!!

COMPONENTS IDENTIFIED BY MARK  ON THE SCHEMATIC DIAGRAM AND IN THE PARTS LIST ARE CRITICAL FOR RISK OF FIRE AND ELECTRIC SHOCK. REPLACE THESE COMPONENTS WITH ONKYO PARTS WHOSE PART NUMBERS APPEAR AS SHOWN IN THIS MANUAL.

MAKE LEAKAGE-CURRENT OR RESISTANCE MEASUREMENTS TO DETERMINE THAT EXPOSED PARTS ARE ACCEPTABLY INSULATED FROM THE SUPPLY CIRCUIT BEFORE RETURNING THE APPLIANCE TO THE CUSTOMER.

**EXPLODED VIEWS-1  
AMPLIFIER SECTION**

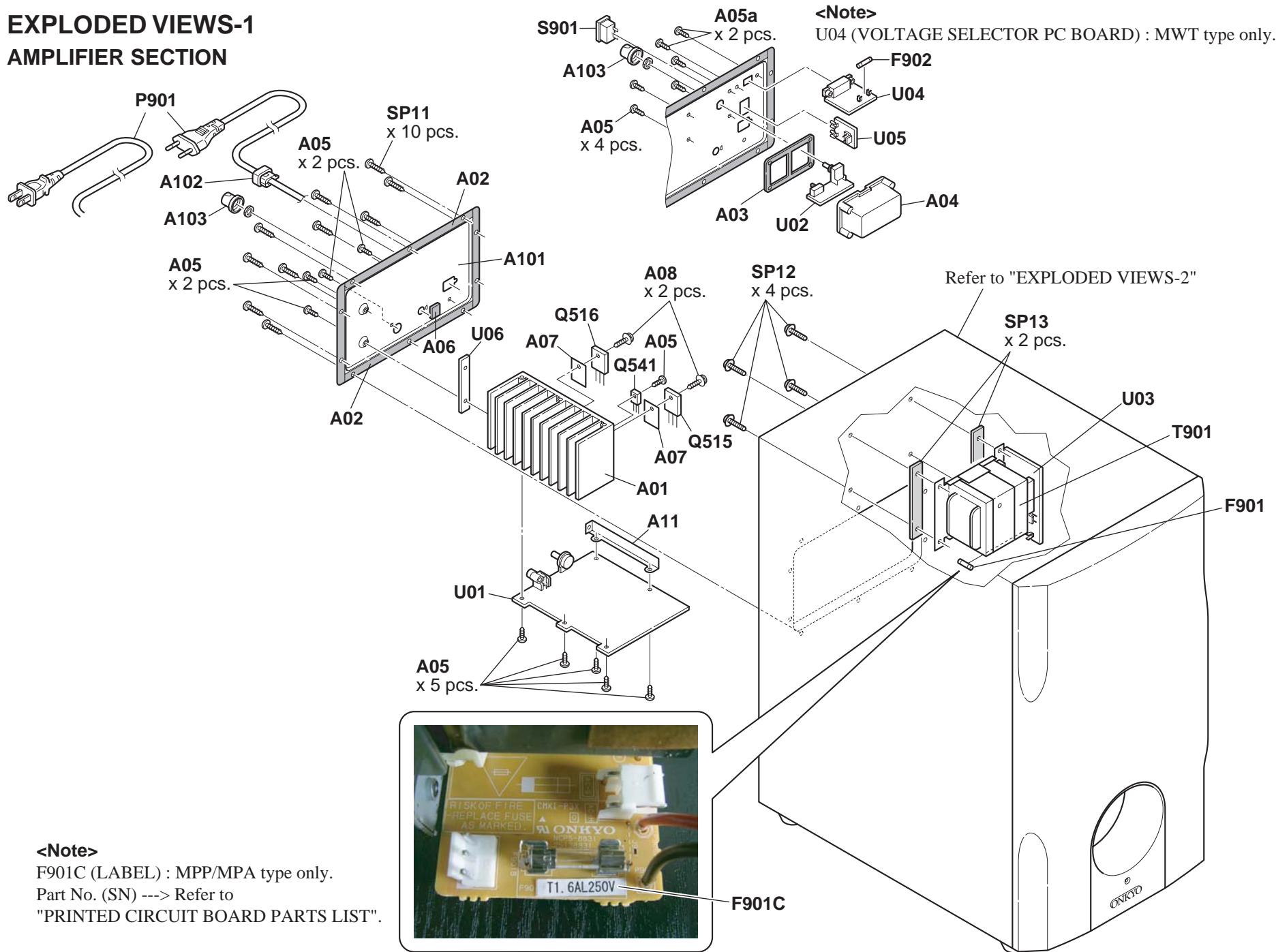

## EXPLODED VIEWS-2 SPEAKER SECTION

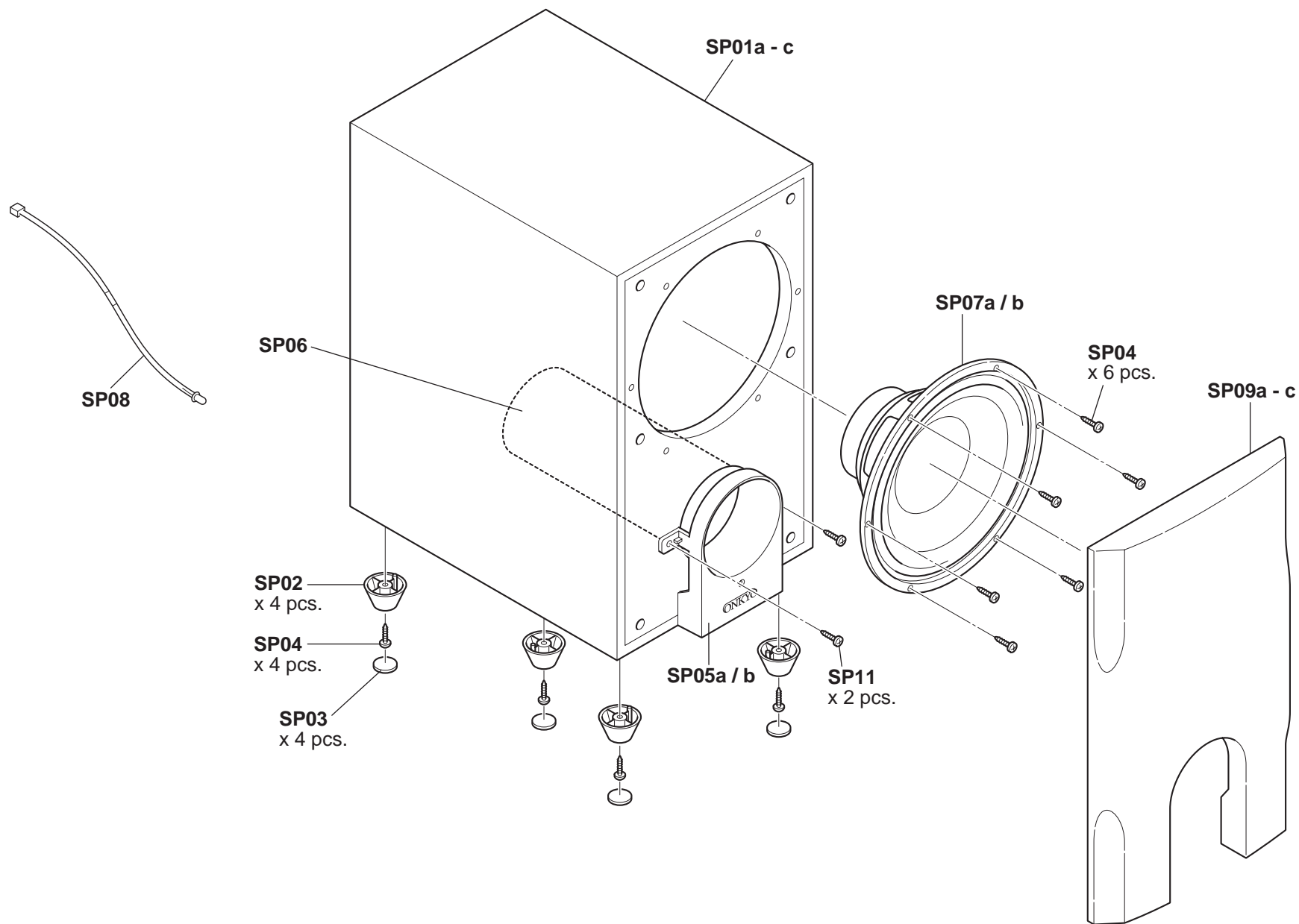

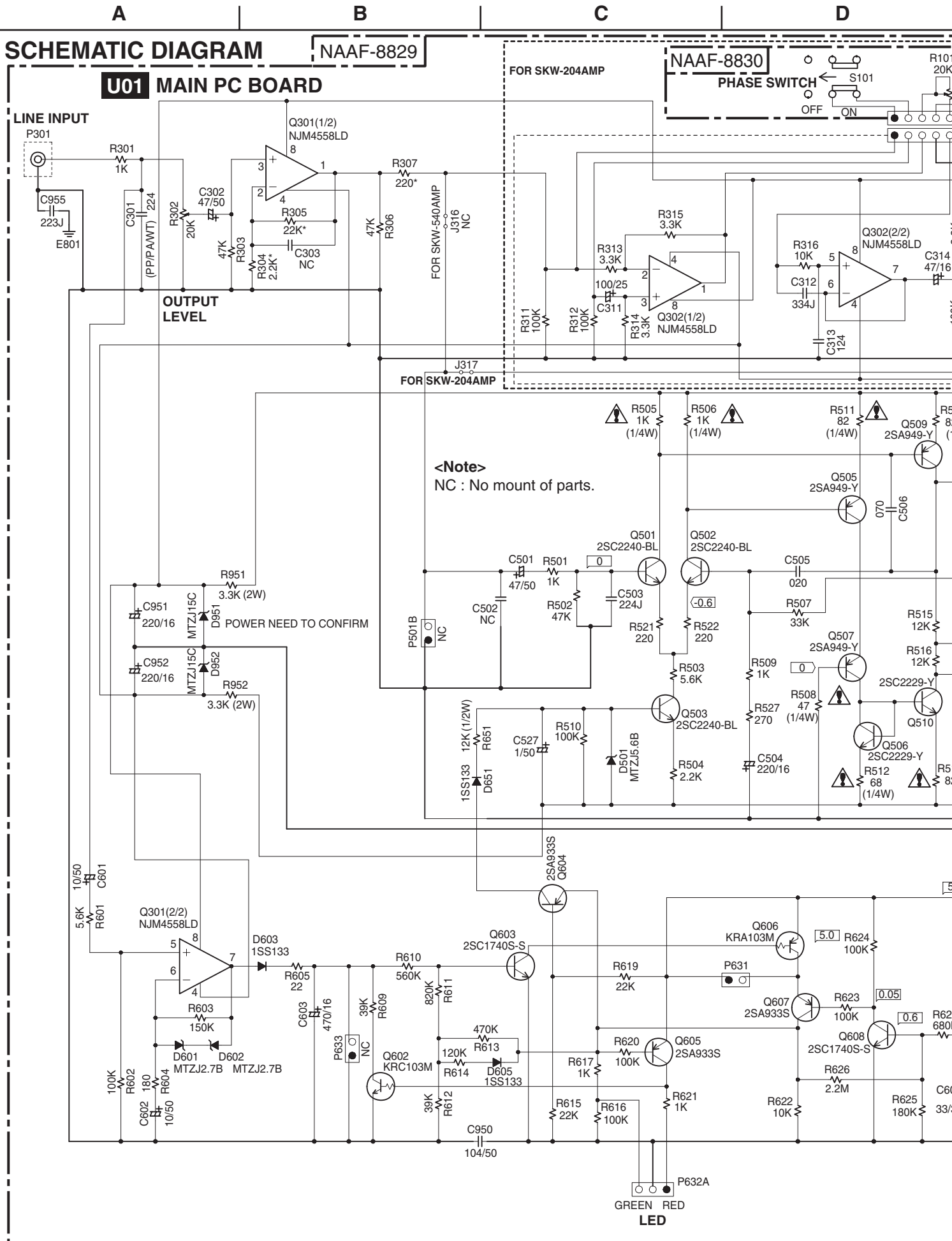

E

F

G

H

**U02 FREQUENCY ADJUSTMENT PC BOARD**  
PHASE SWITCH AND FREQUENCY ADJUST.  
FOR SKW-204AMP

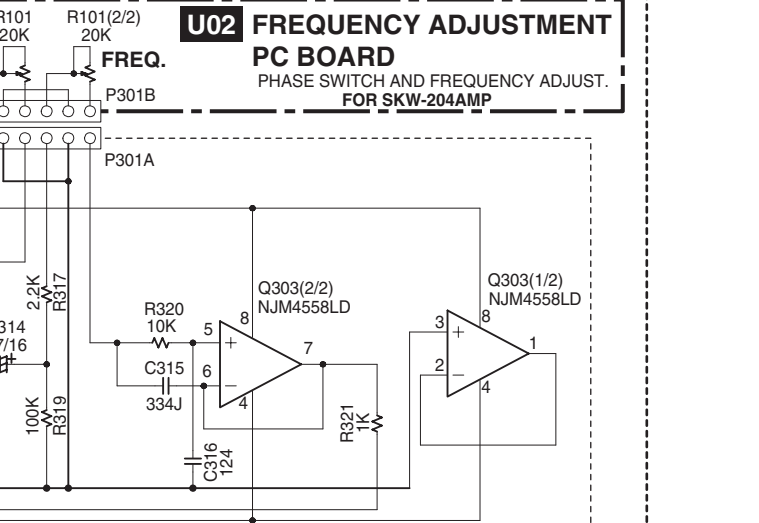

**NOTE**

- THE COMPONENTS IDENTIFIED BY MARK ARE CRITICAL FOR SAFETY. REPLACE ONLY WITH PART NUMBER SPECIFIED.
- VOLTAGE (MEASURED WITH VOLTMETER) IS DC VOLTAGE. (NO INPUT SIGNAL).
- ALL PNP TRANSISTORS ARE EQUIVALENT TO 2SA1015-GR UNLESS OTHERWISE NOTED.
- ALL NPN TRANSISTORS ARE EQUIVALENT TO 2SC1815-GR UNLESS OTHERWISE NOTED.
- ALL DIODES ARE EQUIVALENT TO 1SS133 UNLESS OTHERWISE NOTED.
- ELECTROLYTIC CAPACITORS ( ) ARE IN uF/WV.
- ALL CAPACITORS ARE IN pF/50V UNLESS OTHERWISE NOTED.  
EX) 030- 3pF 330- 33pF 331- 330pF 333- 0.033uF
- ALL RESISTORS ARE IN OHMS 1/4WATTS UNLESS OTHERWISE NOTED.
- THE THICK LINES ON PC BOARD ARE THE PRINTING SIDE OF THE PARTS.  
EX) PRINTING SIDE
- CIRCUIT IS SUBJECT TO CHANGE FOR IMPROVEMENT.

**CAUTION**

FOR CONTINUED PROTECTION AGAINST FIRE HAZARD, REPLACE ONLY WITH FUSE OF SAME TYPE AND RATING INDICATED.



**ATTENTION**

AFIN D'ASSURER UNE PROTECTION PERMANENTE CONTRE LES RISQUES D'INCENDIE, REMPLACER UNIQUEMENT PAR UN FUSIBLE DE MEME TYPE ET CALIBRATION COMME INDIQUE.



THIS SYMBOL LOCATED NEAR THE FUSE INDICATES THAT THE FUSE USED IS SLOW OPERATING TYPE FOR CONTINUED PROTECTION AGAINST FIRE HAZARD, REPLACE WITH SAME TYPE FUSE. FOR FUSE RATING REFER TO THE MARKING ADJACENT TO THE SYMBOL.



CE SYMBOLE INDIQUE QUE LE FUSIBLE UTILISE EST LENT. POUR UNE PROTECTION PERMANENTE, UTILISER QUE DES FUSIBLES DE MEME TYPE. CE DERNIER EST INDIQUE LA QU LE PRESENT SYMBOLE EST APPOSE.

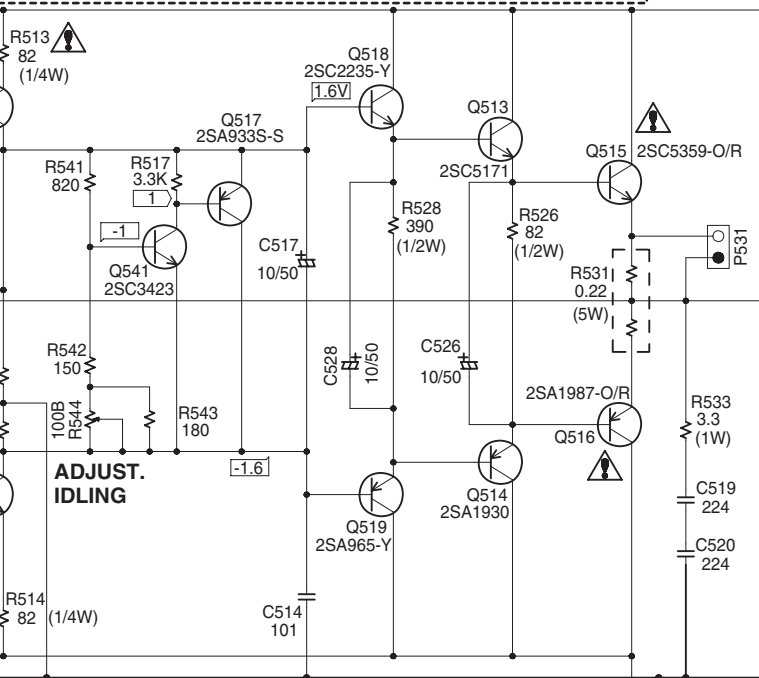

**SPEAKER**

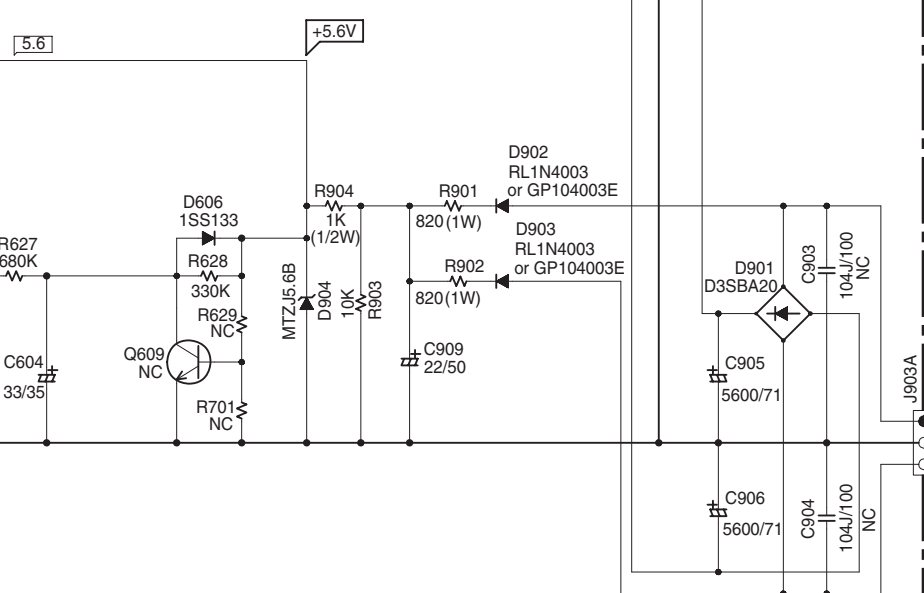

**U03 POWER TRANSFORMER PC BOARD**

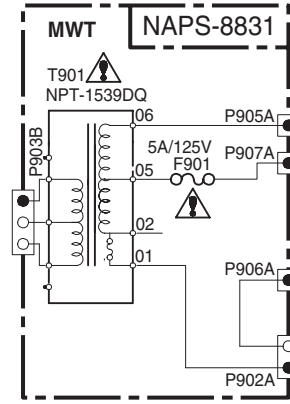

**U04 VOLTAGE SELECTOR PC BOARD**

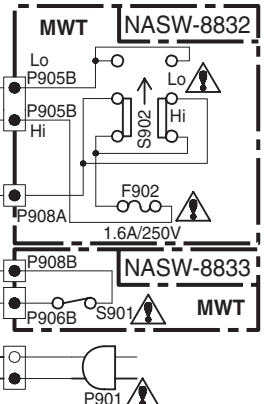

**U05 POWER SWITCH PC BOARD**

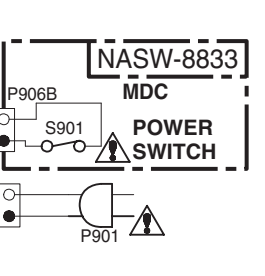
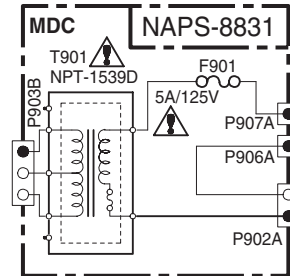
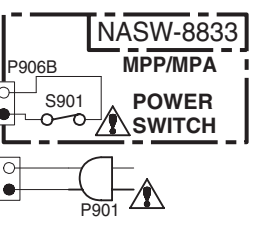
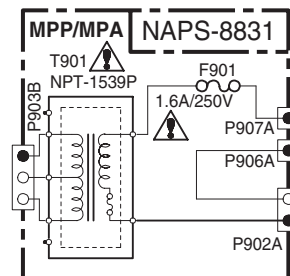

A

B

C

D

PRINTED CIRCUIT BOARD VIEWS-1

**U01** MAIN PC BOARD (NAAF-8829)

Component side

1

2

3

4

5

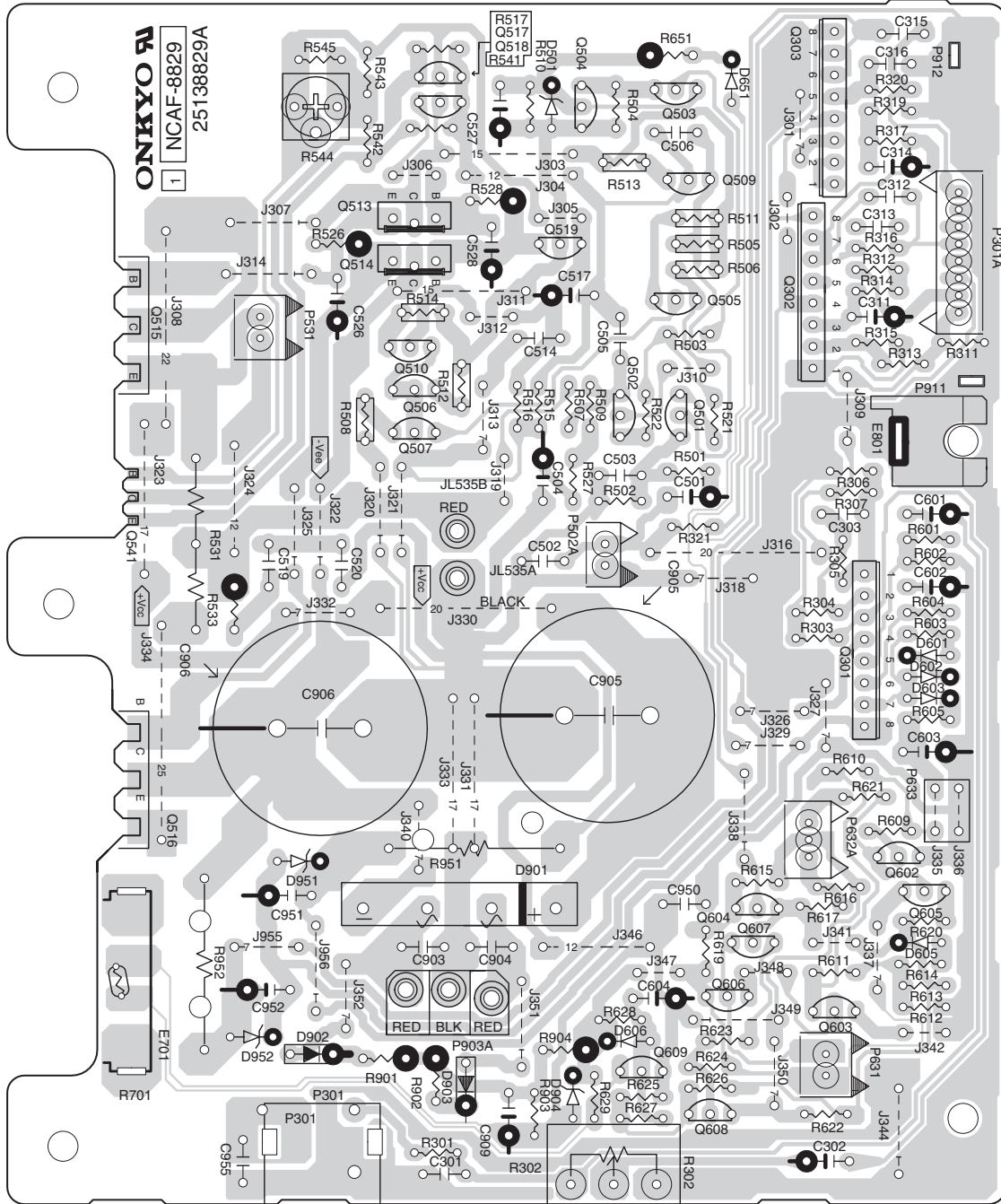

A

B

C

D

PRINTED CIRCUIT BOARD VIEWS-2

1

**U03** POWER TRANSFORMER PC BOARD (NAPS-8831)

Component side

2

3

4

5

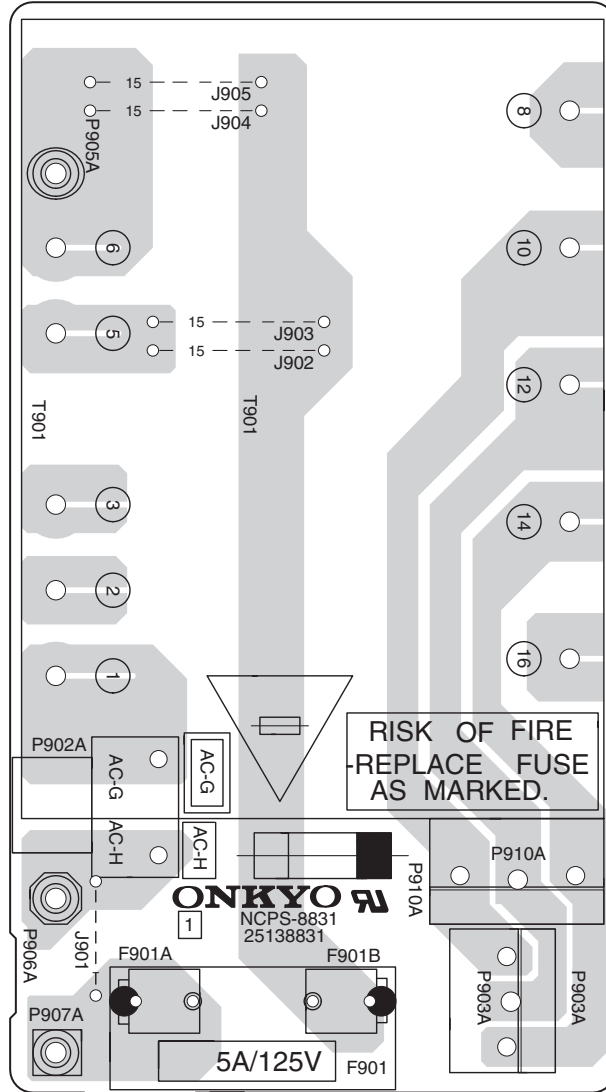

A

B

C

D

PRINTED CIRCUIT BOARD VIEWS-3

1

**U02** FREQUENCY ADJUSTMENT PC BOARD (NAAF-8830)

Component side

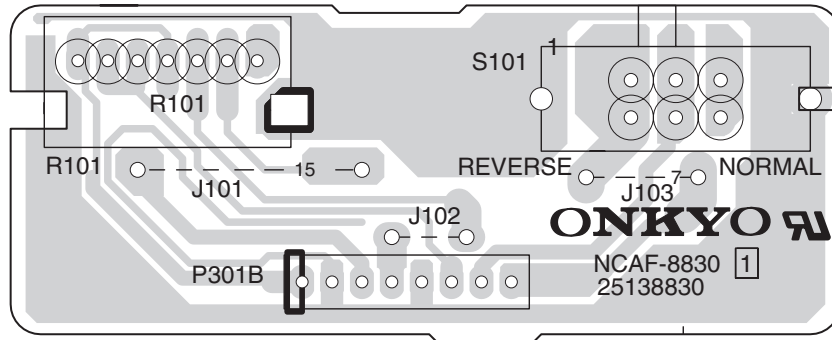

2

**U04** VOLTAGE SELECTOR PC BOARD (NASW-8832)

Component side

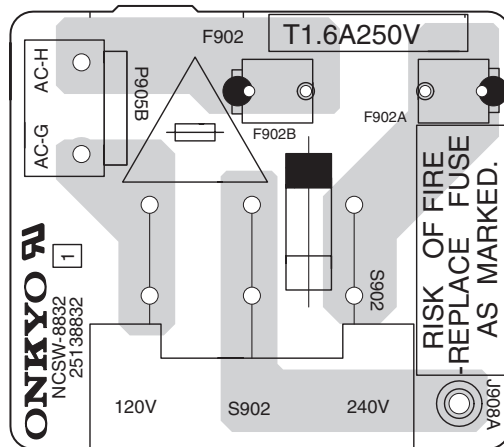

<Note>  
MWT type only

3

4

**U05** POWER SWITCH PC BOARD (NASW-8833)

Component side

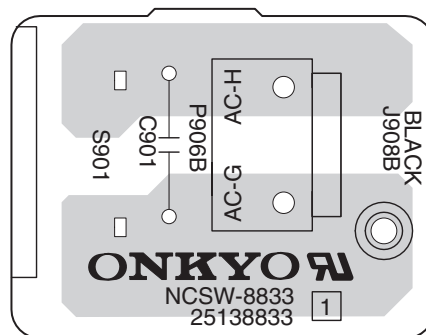

5



## ADJUSTMENT PROCEDURE

### ADJUSTMENT OF IDLING CURRENT

#### [When]

1. Exchange transistors (Q505 - Q519).
2. Exchange MAIN PC board ass'y (NAAF-8829).

#### [Procedure]

<Note> No speaker load and No input signal.

1. Short test point P631 for amplifier is under active mode.
2. Adjust the trimming resistor R544 so that the reading of multimeter becomes 52 ohm to 53 ohm.
3. Connect the DC voltmeter to test point P531. <Fig-1>
4. Connect the AC power cord into a wall outlet.
5. Press POWER button to turn on the unit.
6. Confirm the voltage of above point after 6 minutes to 8 minutes. (Heat running)
7. When less than 3.20 mV : Readjust the trimming resistor above so that the voltage becomes 4.5 mV to 5.0 mV.  
When 3.30 mV to 5.20 mV : Not necessary to adjust.  
When 5.21 mV to 10.0 mV : Readjust the trimming resistor above so that the voltage becomes 5.0 mV to 5.5 mV.  
When 10.1 mV to 20.0 mV : Readjust the trimming resistor above so that the voltage becomes 5.6 mV to 6.0 mV.
8. Press POWER button to turn off the unit.
9. Disconnect the DC voltmeter.
10. Disconnect the AC power cord from a wall outlet.

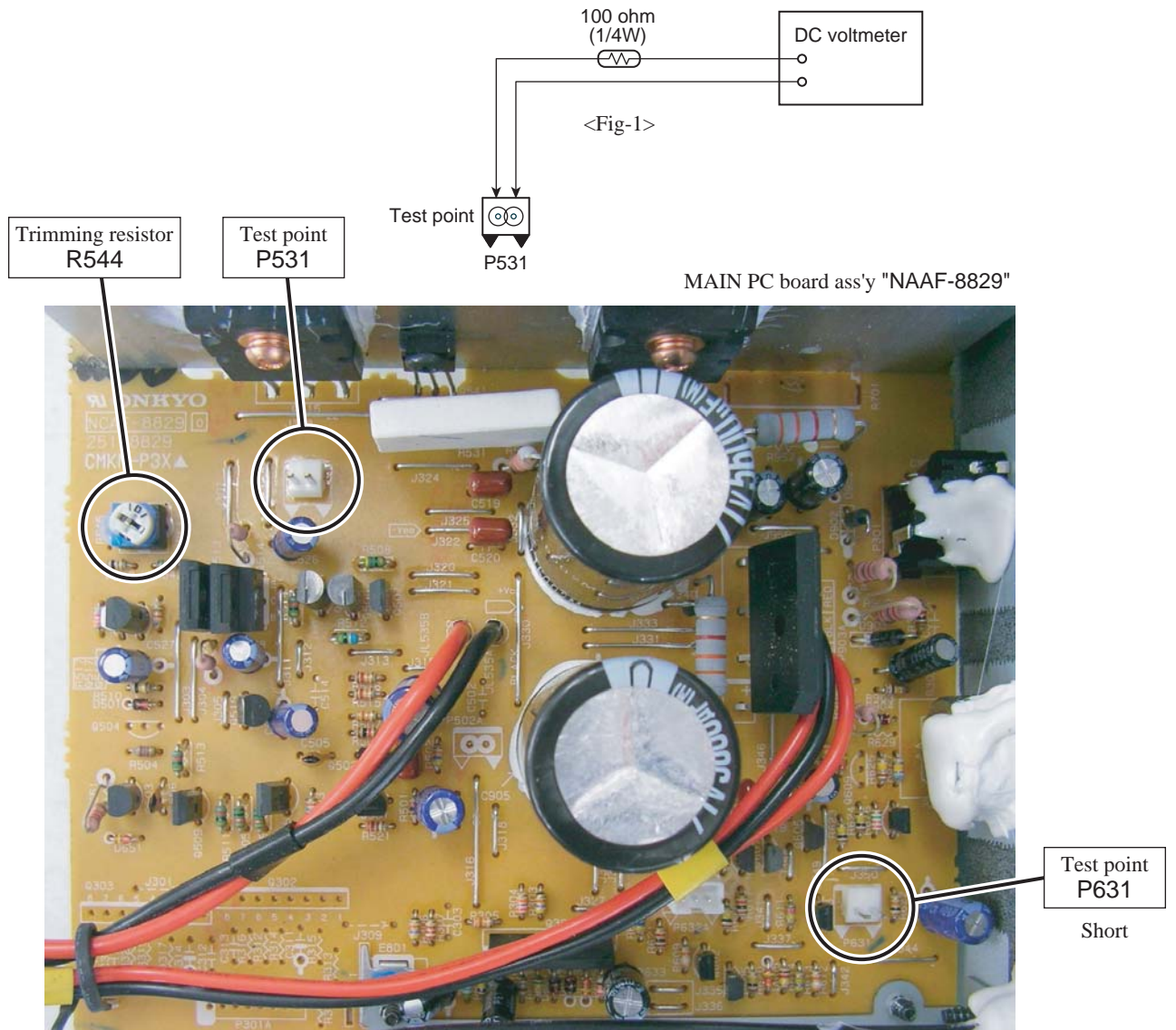

# PACKING PROCEDURE

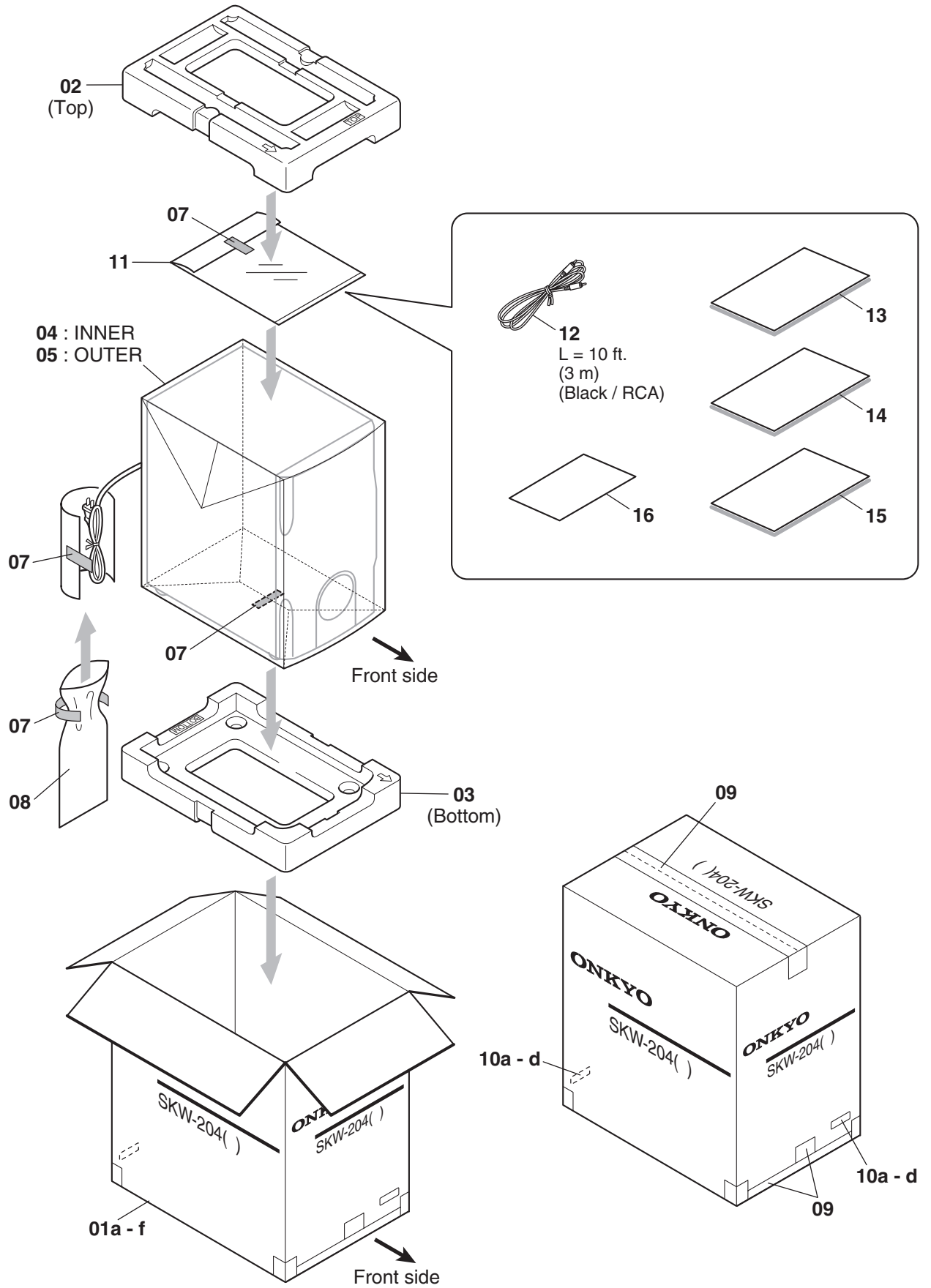

**ONKYO CORPORATION**

Sales & Product Planning Div. : 2-1, Nisshin-cho, Neyagawa-shi, OSAKA 572-8540, JAPAN  
Tel: 072-831-8023 Fax: 072-831-8124

**ONKYO U.S.A. CORPORATION**

18 Park Way, Upper Saddle River, N.J. 07458, U.S.A.  
Tel: 201-785-2600 Fax: 201-785-2650 <http://www.us.onkyo.com/>

**ONKYO EUROPE ELECTRONICS GmbH**

Liegnitzerstrasse 6, 82194 Groebenzell, GERMANY  
Tel: +49-8142-4401-0 Fax: +49-8142-4401-555 <http://www.eu.onkyo.com/>

**ONKYO EUROPE UK Office**

Suite 1, Gregories Court, Gregories Road, Beaconsfield, Buckinghamshire, HP9 1HQ  
UNITED KINGDOM Tel: +44-(0)1494-681515 Fax: +44(0)-1494-680452

**ONKYO CHINA LIMITED**

Units 2102-2107, Metroplaza Tower I, 223 Hing Fong Road, Kwai Chung,  
N.T., HONG KONG Tel: 852-2429-3118 Fax: 852-2428-9039  
<http://www.ch.onkyo.com/>

