

# ONKYO® SERVICE MANUAL

## STEREO CASSETTE

## TAPE DECK

## Model TA-1900

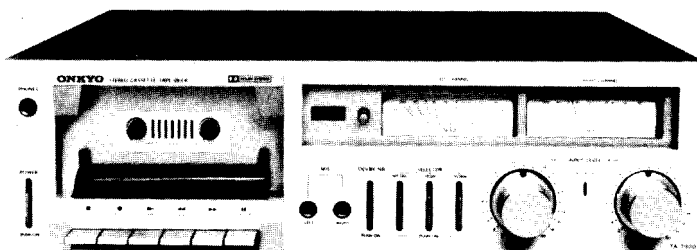

### TABLE OF CONTENTS

Item	Page
Specifications	2
Features	2
Service procedures	3
Mechanism operation	3
Alignment procedures	4
Exploded view	6
Mechanism-exploded view	7
PC board view (G/W model)	9
PC board-parts list (G/W model)	10
Schematic diagram (G/W model)	11
PC board view (D model)	13
PC board-parts list (D model)	14
Schematic diagram (D model)	15
Component location	17
Packing procedures	18

**ONKYO®**  
**AUDIO COMPONENTS**

## SPECIFICATIONS

<b>Track System :</b>	4-track, 2-channel stereo	<b>Outputs :</b>	Line Out : 2
<b>Recording System :</b>	AC bias		Output level :
<b>Erasing System :</b>	AC erase		350 mV (at 0 VU)
<b>Tape Speed :</b>	4.8 cm/sec.		Optimum load impedance :
<b>Wow and Flutter :</b>	0.07% (WRMS)		more than 50 k $\Omega$
<b>Frequency Response :</b>	30 – 14,000 Hz (30 – 13,000 Hz $\pm$ 3dB) (normal position tape)		DIN Jack : 1 (Only Q, W/G model)
	30 – 15,000 Hz (30 – 14,000 Hz $\pm$ 3dB) (high position tape)		Standard output level :
	30 – 15,000 Hz (30 – 14,000 Hz $\pm$ 3dB) (metal position tape)		350 mV (0VU)
<b>Signal-to-Noise Ratio :</b>	56 dB (metal position tape, Dolby NR out)	<b>Motor :</b>	Optimum load impedance :
	A noise reduction of 10 dB above 5 kHz and 5 dB at 1 kHz is possible with the Dolby NR in	<b>Heads :</b>	more than 50 k $\Omega$
<b>Input Jacks :</b>	Microphone Jacks : 2	<b>Semiconductors :</b>	Headphone Jack : 1
	Minimum input level :		Optimum impedance :
	0.3 mV/600 $\Omega$		8 $\Omega$ /200 $\Omega$
	Input impedance :		DC servo motor : 1
	5 k $\Omega$		hard permalloy head and three-gap ferrite erase head
	Optimum mic impedance :		TR : 16 Diodes : 11 IC : 2
	600 $\Omega$ – 50 k $\Omega$		LED : 6 (Only Q, W/G model)
	Line In : 2	<b>Power supply :</b>	TR : 14 Diodes : 11 IC : 2
	Minimum input level :		LED : 6 (Only D model)
	50 mV		120V/60Hz, 220V/50Hz, 120/220V, 50/60Hz or 240V/50Hz
	Input impedance :	<b>Power Consumption :</b>	12W
	50 k $\Omega$	<b>Dimensions :</b>	418(W) x 120(H) x 290(D) mm
	DIN Jack : 1 (Only Q, W/G model)		16-1/2" x 4-3/4" x 11-7/16"
	Minimum input level :	<b>Weight :</b>	4.8 kg (10,6 lbs).
	0.1mV/ 1k $\Omega$	<b>Accessories :</b>	Pin-type connecting cords : 2
	Input impedance :		
	1 k $\Omega$		

\*Specifications and external appearance are subject to change without notice because of product improvements.

## FEATURES

### Hard Permalloy Head for Metal Tapes

To bring out the full potential of metal tape formulations, the TA-1900 employs a new hard permalloy having superior magnetic properties for the rec/pb head. The result is a wide dynamic range, extended high range frequency response and excellent resistance to abrasion.

### Direct Loading System

The convenient direct loading system facilitates sure and quick loading and unloading of cassettes. And because everything is up front, the inner parts are readily accessible for cleaning and demagnetizing.

### Dolby Noise Reduction System

When turned on during recording and playback, this system reduces tape hiss and raises S/N ratio by up to 10 dB above 5 kHz.

### Full Auto-Stop Mechanism

Full automatic stop at the end of the tape safeguards both tapes and tape transport from undue strain.

You are now the owner of a very high quality stereo cassette tape deck. To ensure many long years of listening enjoyment free of trouble, read this manual carefully and familiarize yourself with all facets of operation. Failure to do so may result in loss of performance and also in possible malfunction.

**MECHANISM-EXPLODED VIEW**

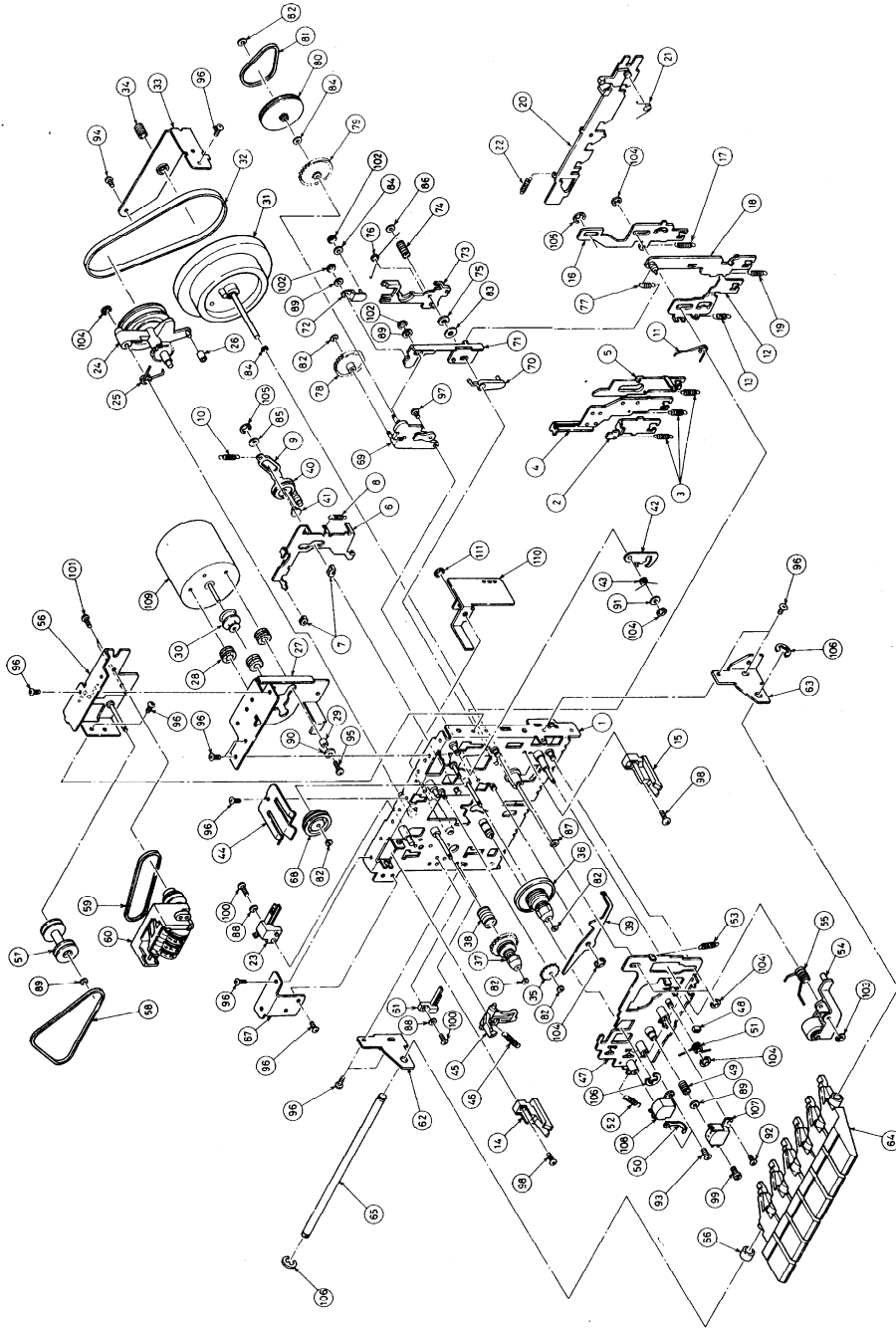

REF. NO.	PARTS NO.	DESCRIPTION
41	24610467	Bush
42	24603161	Lever
43	24605232	Spring for 42
44	24603233	Spring Plate
45	24603162	Lever
46	24605234	Spring for 45
47	24610468	Slide ass'y
48	24610469	Spacer
49	24605235	Spring for azimuth
50	24610455	Terminal
51	24605236	Spring for 47
52	24603237	Spring for 47
53	24605238	Spring for 47
54	24610471	Pinch lever ass'y
55	24605239	Spring for 54
56	24610472	Bracket, counter
57	24601078	Pulley
58	24602093	Belt
59	24602094	Belt, counter
60	24601074	Counter
61	24603163	Mixing switch
62	24610473	Bracket
63	24610474	Bracket
64	28320444	Button
65	24604038	Shaft, button
66	24604039	Pipe
67	24610475	Bracket
68	24610476	Clutch, auto-stop
69	24610477	Base
70	24610478	Arm
71	24603164	Lever
72	24610479	Arm
73	24610480	Arm
74	24605240	Spring
75	24610481	Washer
76	24605241	Spring
77	24605242	Spring
78	24602095	Gear
79	24602096	Gear
80	24601079	Pulley
81	24602097	Belt
82	24610482	φ 1.6 x φ 3.5 x 10.25, Washer
83	24610483	φ 1.9 x φ 8 x 10.5, Washer
84	24610484	φ 2.1 x φ 4 x 10.25, Washer
85	24610485	φ 4.1 x φ 8 x 10.25, Washer
86	24610486	φ 1.55 x φ 6 x 10.5, Washer
87	24610487	φ 1.9 x φ 5 x 10.5, Washer
88	24610488	φ 2, Washer
89	24610489	φ 2.6, Washer
90	24610490	φ 3, Washer
91	82112004	2 x 4, Screw
92	82112006	2 x 6, Screw
93	801177	2.6 x 5, Screw
94	801178	2.6 x 8, Screw
95	833126047	2.6 x 4, Screw
96	833126087	2.6 x 5, Screw
97	833126087	2.6 x 8, Screw
98	81512006	2 x 6, Screw
99	833120062	3 x 6, Screw
100	833120062	3 x 6, Screw
101	890096	CS2, Circlip
102	893015	E-1.5, Stop ring
103	893015	E-2.5, Stop ring
104	893015	E-3, Stop ring
105	893010	E-4, Stop ring
106	893040	E-4, Stop ring
107	24600022	Roller, play idler
108	24600022	Motor ass'y
109	24603231	Arm, pause
110	24610465	Bracket, motor
111	893025	E-2.5, Circlip

**MECHANISM EXPLODED VIEW - PARTS LIST**

REF. NO.	PARTS NO.	DESCRIPTION
1	24610456	Chassis
2	24603153	Lever, stop
3	24605221	Spring for 2, 4 & 5
4	24603154	Lever, recording
5	24603155	Lever, playback
6	24603156	Lever, brake
7	24610457	Brake rubber
8	24605222	Spring for 6
9	24603157	Lever, play idler
10	24605224	Spring for 9
11	24603158	Spring for fast forward
12	24603158	Spring for fast forward
13	24603225	Spring for 12
14	27190084	Holder (L)
15	27190083	Holder (R)
16	24610458	Slide, rewind
17	24605226	Spring for 16
18	24603159	Lever, pause
19	24605227	Spring for 18
20	24610459	Slide
21	24605228	Spring for auto-stop
22	24605229	Spring for 20
23	24603160	Lever switch, motor
24	24610460	Clutch
25	24605230	Spring
26	24604036	Pipe
27	24610461	Bracket, motor
28	24610462	Cushion
29	24604037	Pipe
30	24601076	Motor ass'y (30 & 109)
31	24601077	Pulley
32	24602088	Flywheel
33	24602089	Belt
34	24610463	Bracket
35	24610464	Bearing
36	24607092	Gear
37	24602090	Take-up reel
38	24602091	Supply reel
39	24605231	Arm, pause
40	24610465	Bracket, motor
41	24610466	Router, play idler

## SERVICE PROCEDURES

### Head Cleaning

Sound quality is greatly influenced by accumulation of magnetic particles on the recording/playback head. For the clearest possible sound, be sure to clean the head periodically, normally 2 – 3 times a month. A dirty head will cause:

- Poor sound quality (loss of high sounds)
- Decreased volume
- Skipping
- Poor erasing (incomplete erasure of previous recording)

To prevent these problems, clean the head and capstan shaft with a cleaning pen or a cotton swab dipped in a little alcohol.

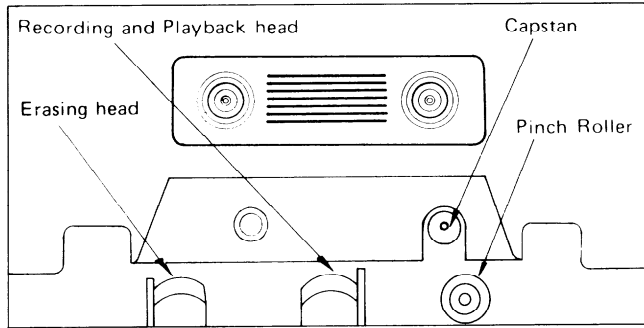

### Pinch Roller Cleaning

If the pinch roller is dirty, the tape may become tangled and damaged by wrapping around the roller. Clean the pinch roller when cleaning the head. Use a special cleaner and cotton swab. Head cleaning materials must never be used for the pinch roller.

### Demagnetizing

Residual magnetism builds up in the head after the cassette deck had been used for a long period. This build-up introduces noise and static into recording tapes and lowers the high frequency range. To prevent this, demagnetize the erasing and recording/playback heads as other affected metal parts (like the capstan shaft) once every 50 hours of use. Keep the tape deck power OFF while using the demagnetizer. Also place recording tapes far away from the work area.

## TAPE SELECTOR GUIDE

TAPE SELECTOR BRAND	EQ/BIAS NORMAL (120 μs)	EQ/BIAS HIGH (70 μs)	EQ/BIAS METAL (70 μs)
*MAXELL	XL-I	XL-II	MX
AGFA	SUPER HIGH DYNAMIC	CHROM	
AMPEX	GRAND MASTER I	GRAND MASTER II	
BASF	Professional I Studio I	Professional II Studio II	Metal IV
FUJI	FL FX-1	FX-II	
MAXELL	LN UD	CR	
MEMOREX	MEMOREX (120 μ)	MEMOREX (70 μ)	
RKO	BROADCAST-I		
SCOTCH	MASTER I	MASTER II	METAFINE
SONY	LN HFX SHF LNX	CR EHF (CD-α)	METALLIC
TKD	AD ED D OD	SA SA-X	MA MA-R

## MECHANISM OPERATION

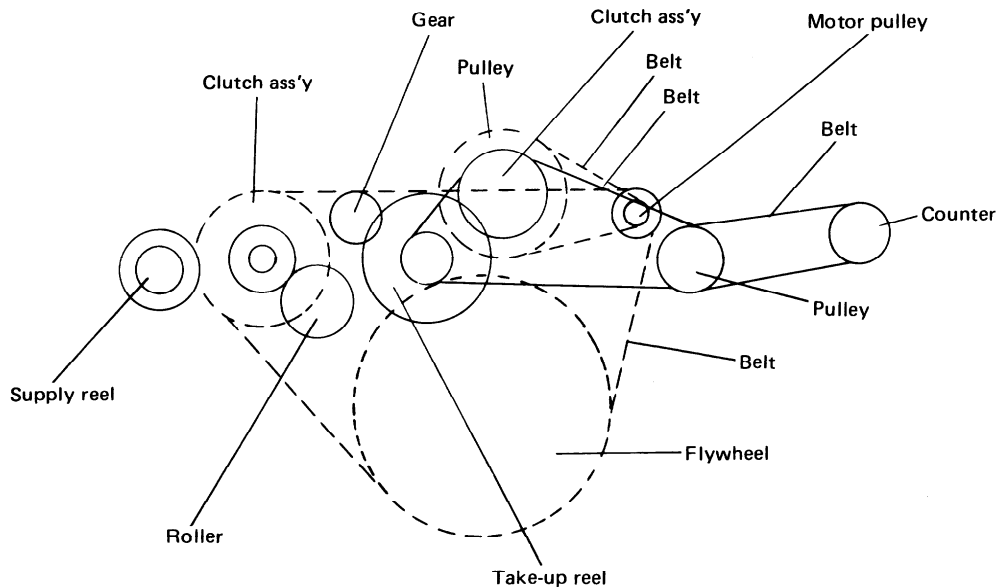

## ALIGNMENT PROCEDURES

### PRECAUTIONS

#### 1. Tape required :

- (1) Blank tape
 

MAXELL	UD-XL/I	(Normal)
	UD-XL/II	(High)
	MX	(Metal)
- (2) Test tape
 

VICTOR	VTT-658	10 kHz, -15 dB
TEAC	MTT-111	3 kHz, -10 dB
	MTT-150	Dolby level calibration-tone.

### 1. PLAYBACK MODE ADJUSTMENT

#### 1-1 Head azimuth adjustment

##### PROCEDURES :

- 1) Play the 10 kHz portion of the test tape VTT-658 back. Adjust the head azimuth adjusting screw for maximum V.T.V.M. read.
- 2) If the peak output reads of the right and left channels are different, set the screw to obtain the mechanical center between the peaks.
- 3) After adjustment, lock the screw with bond.

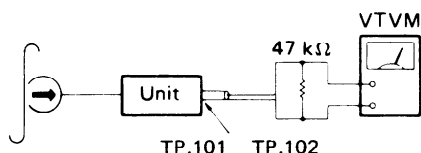

#### 1-2 Tape speed adjustment

##### PROCEDURES :

Play the 3 kHz portion of the test tape MTT-111 back. Adjust the tape speed adjusting semi-fixed resistor in the motor for 3,000 to 3,010 Hz counter indication.

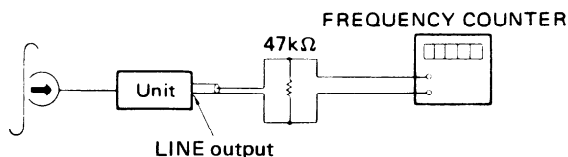

#### 1-3 Playback output adjustment

##### PROCEDURES :

- 1) Play the test tape MTT-150 back, adjust R 119 and R120 for 775 mV V.T.V.M. read.

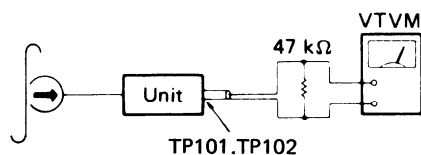

### 2. Instrument required :

- (1) AC VTVM
- (2) Frequency counter
- (3) AF oscillator
- (4) Attenuator

### 3. The switches and controls should be set as follows unless otherwise specified.

- |                        |        |
|------------------------|--------|
| Tape selector switch : | Normal |
| Dolby NR switch :      | Out    |
| Accubias adjust :      | Center |

#### 1-4 VU meter adjustment

##### PROCEDURES :

- 1) Play the test tape MTT-150 back.
- 2) Adjust R 183 and R 184 until the VU meter pointer deflects to the Dolby mark (∞, +3 dB) on the meter.

### 2. RECORDING MODE ADJUSTMENT

#### 2-1 Record bias adjustment

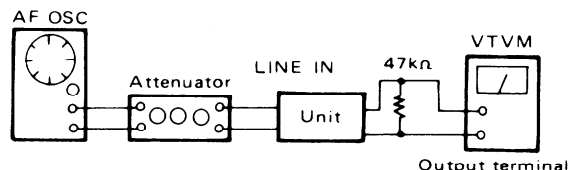

- 1) Press the pause key, and put the tape deck into recording mode. Apply a 400 Hz signal to the Line input terminals, and adjust the AF oscillator output so that the VU meter reads 0 VU.
- 2) Then set the input level to -10 dB, and release the pause switch to record on the tape. Read the output level when this recording is played back again.
- 3) Next change the frequency of the oscillator to 8 kHz, and record again as described above. During playback of this recording, obtain the same output level as with the 400 Hz recording by readjusting R189 and R190

#### 2-3 Record-playback output level adjustment

##### PROCEDURES :

- 1) Connect the 1 kHz input signal to the line in terminal.
- 2) Connect the VTVM to the output terminal.
- 3) Set the tape deck in the recording mode of operation.
- 4) Adjust the attenuator for 350 mV VTVM read.
- 5) Set the deck in the playback mode of operation.
- 6) Adjust the R155 and R156 for 350 mV VTVM read.

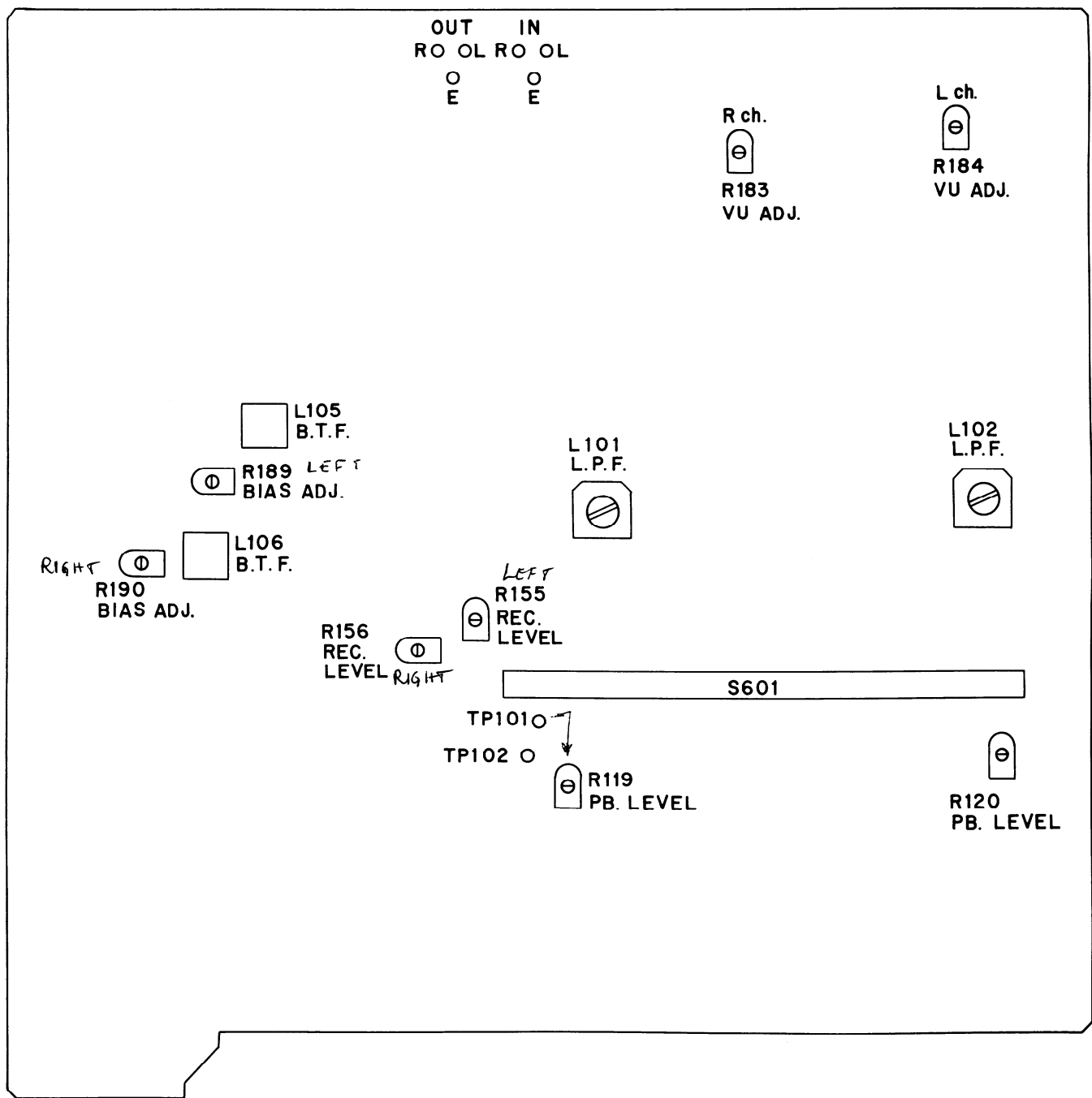

**3. Current consumption (motor)**

Playback :	Less than 100 mA
Recording :	Less than 100 mA
Fast forward :	Less than 130 mA
Rewind :	Less than 130 mA
Auto-Stop	
Playback-Stop :	Less than 180 mA

**4. Mechanism specifications**

- 1) Tape speed : 4.8 cm/sec. (3,000 Hz~ 3,010 Hz) Use a standard test tape, VTT-658 (3 kHz) or equipment.
- 2) Wow and Flutter : Less than 0.09% (WRMS)
- 3) Take-up torque : 35 - 70 gr-cm
- 4) F.F. torque : 60 - 150 gr-cm
- 5) Rewind torque : 60 - 150 gr-cm
- 6) Rewind time : Less than 100 sec.  
(Use a C-60 cassette tape)
- 7) Automatic shut-off time : Less than 5 sec.

**SCHEMATIC DIAGRAM**  
120V model

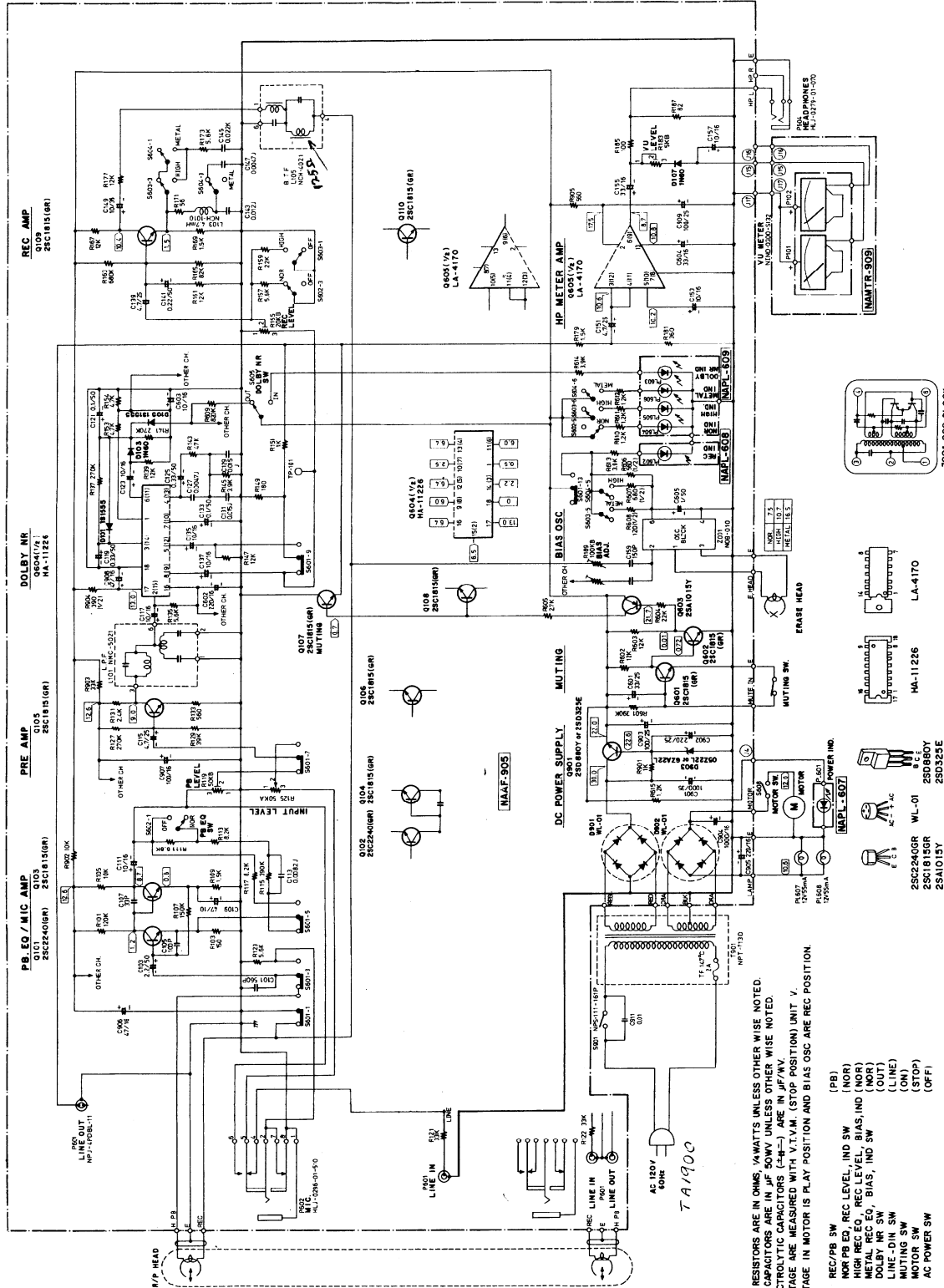

- NOTES**
- ALL RESISTORS ARE IN OHMS,  $\mu$ WATTS UNLESS OTHERWISE NOTED.
  - ALL CAPACITORS ARE IN  $\mu$ F 50WV UNLESS OTHERWISE NOTED.
  - ELECTROLYTIC CAPACITORS (E-F) ARE IN  $\mu$ F/WV.
  - VOLTAGE IS MEASURED WITH V.T.M. (STOP POSITION) UNIT V.
  - VOLTAGE IN MOTOR IS PLAY POSITION AND BIAS OSC ARE REC POSITION.
- S801 REC/PB SW (PB)  
 S802 NOR PB ED, REC LEVEL, IND SW (NOR)  
 S803 HIGH REC EQ, REC LEVEL, BIAS, IND (NOR)  
 S804 REC EQ, BIAS, IND SW (NOR)  
 S805 DOLBY NR SW (OUT)  
 S806 LINE-DIN SW (LINE)  
 S807 MUTING SW (ON)  
 S808 MOTOR SW (STOP)  
 S809 AC POWER SW (OFF)

**ONKYO CORPORATION**

2001 OSC BLOCK  
SCHEMATIC DIAGRAM  
BOTTOM VIEW

**SCHEMATIC DIAGRAM**

G/W model

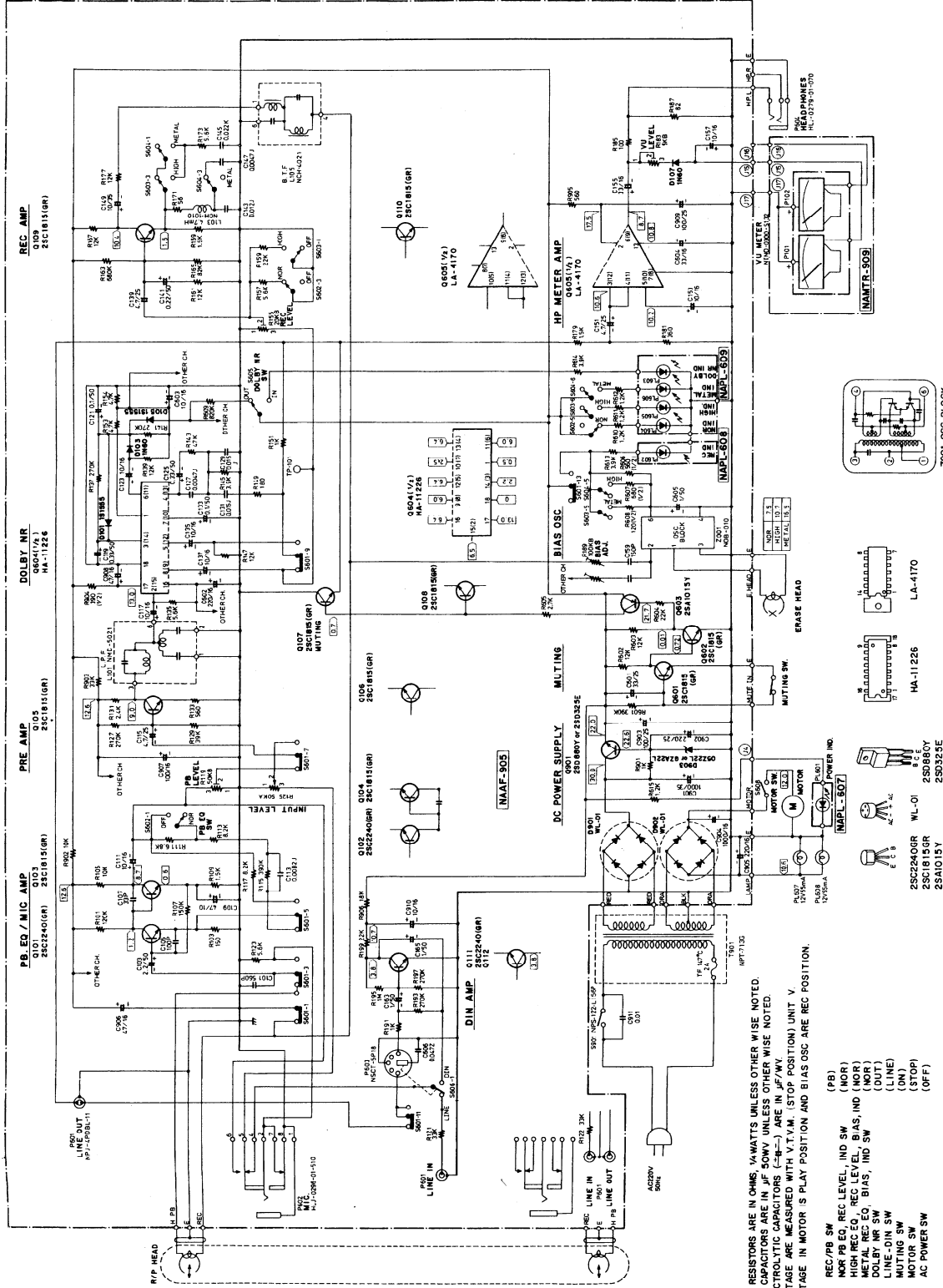



# EXPLODED VIEW

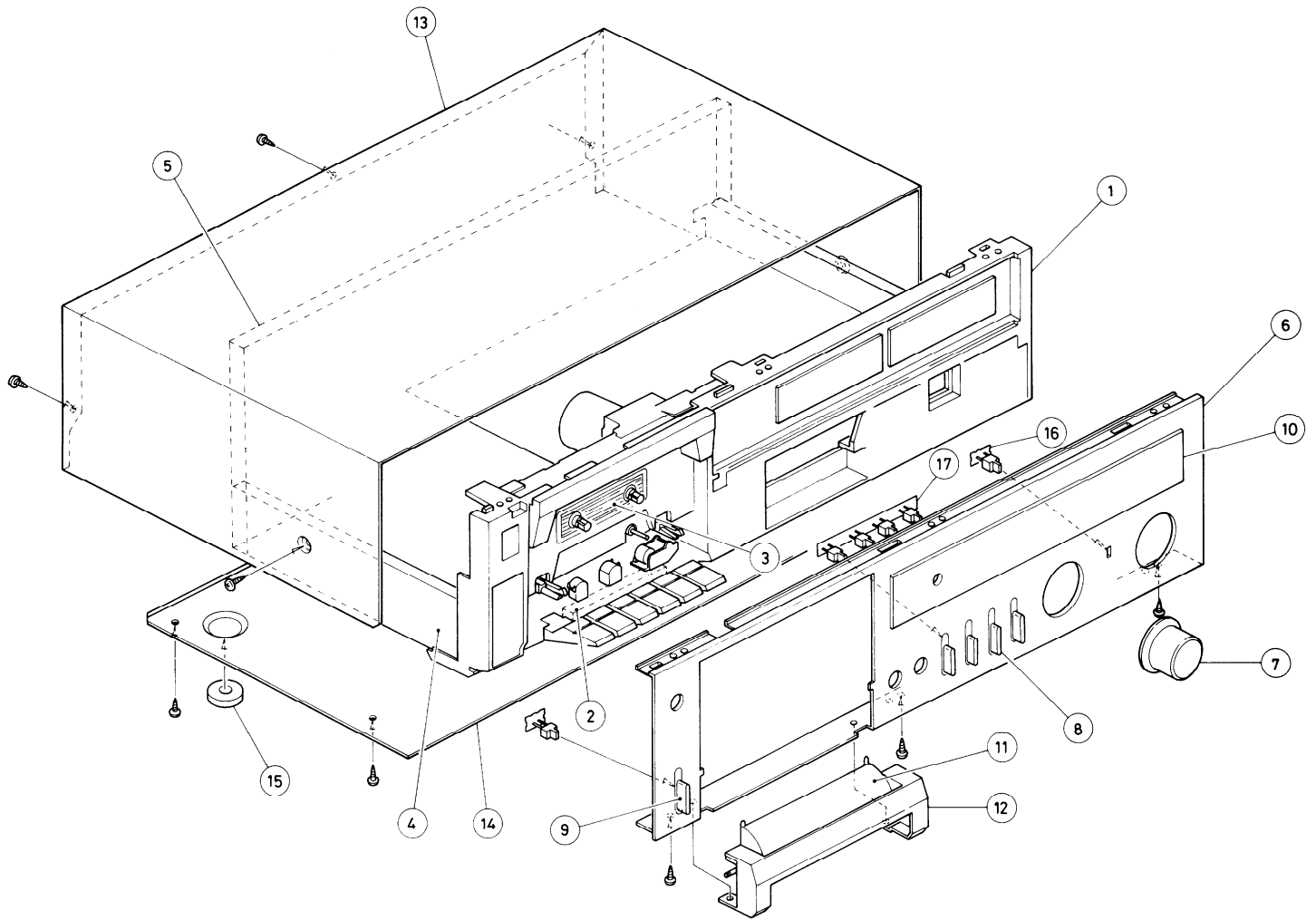

## EXPLODED VIEW – PARTS LIST

REF. NO.	PARTS NO.	DESCRIPTION
1	27110114	Front bracket
2	28140270A	Cushion
3	27262065	Plate
4	27115072	Side bracket
5	27120250	Back panel (D model)
	27120251	Back panel (G model)
	27120252	Back panel (W model)
6	16319121	Front panel ass'y
7	28320442	Input level control knob
8	28320445	Knob, push
	27267073	Guide, push
9	28320341A	Knob, power
	27267078	Guide, power
10	28191062	Glass plate
11	27300320	Head cover
12	27300319	Cassette frame
13	28184091	Top cover
14	27170085	Bottom board
15	27175011B	Leg
16	16319507	NAPL-907, Indicator pc board ass'y
17	16319508	NAPL-908, Indicator pc board ass'y

**PRINTED CIRCUIT BOARD – PARTS LIST  
REC. AND PLAYBACK AMPLIFIER PC BOARD**

<b>CIRCUIT NO.</b>	<b>PARTS NO.</b>	<b>DESCRIPTION</b>
<b>Transistors</b>		
Q101, Q102	2211405	2SC2240 (GR)
Q103 – Q110	2211255	2SC1815 (GR)
Q111, Q112	2211405	2SC2240 (GR)
Q601, Q602	2211255	2SC1815 (GR)
Q603	2211454	2SA1015 (Y)
Q901	2201074 or 2201035	2SD880 (Y) or 2SD325 (E)
<b>ICs</b>		
Q604	222460	HA-11226
Q605	222543	LA-4170
<b>Diodes</b>		
D101, D102	223133 or	DS442X or
D105, D106	223105	1S1555
D103, D104	223132	1K60
D107, D108	223132	1K60
D901, D902	223862	WL-01
D903	224123 or 224068	GZA22L or 05Z22L
<b>Coils</b>		
L101, L102	233221	NMC-5021
L103, L104	24606072	NCH-1010
L105, L106	233146	NCH-4021
Z001	24606102	NOB-010
<b>Resistors</b>		
R119, R120	5215023	N08HR50KBC, Semi-fixed
R125, R126	5146024	N16RL50KA35, Input level variable
R155, R156	5215022	N08HR20KBC, Semi-fixed
R183, R184	5215020	N08HR5KBC, Semi-fixed
R189, R190	5215024	N08HR100KBC, Semi-fixed
R606	441525614	560Ω, 1/2W, Metal oxide film
R607	441526814	680Ω, 1/2W, Metal oxide film
R608	441521214	120Ω, 1/2W, Metal oxide film
<b>Capacitors</b>		
C103, C104	352780229T	2.2μF, 50V, Elect.
C109, C110	352734709T	47μF, 10V, Elect.
C111, C112	352741009T	10μF, 16V, Elect.
C115, C116	352750479T	4.7μF, 25V, Elect.
C117, C118	352741009T	10μF, 16V, Elect.
C119, C120	352783399T	0.33μF, 50V, Elect.
C121, C122	352781099T	0.1μF, 50V, Elect.
C123, C124	352741009T	10μF, 16V, Elect.
C125, C126	352783399T	0.33μF, 50V, Elect.
C133, C134	352781099T	0.1μF, 50V, Elect.
C135 – C138	352741009T	10μF, 16V, Elect.
C139, C140	352750479T	4.7μF, 25V, Elect.
C141, C142	352782299T	0.22μF, 50V, Elect.
C149, C150	352761009T	10μF, 35V, Elect.
C151, C152	352750479T	4.7μF, 25V, Elect.
C153, C154	352741009T	10μF, 16V, Elect.
C155, C156	352743309T	33μF, 16V, Elect.
C157, C158	352741009T	10μF, 16V, Elect.
C163 – C166	352780109T	1μF, 50V, Elect.
C601	352753309T	33μF, 25V, Elect.
C602	352742219	220μF, 16V, Elect.
C603	352741009T	10μF, 16V, Elect.
C604	352743309T	33μF, 16V, Elect.
C605	352780109T	1μF, 50V, Elect.
C901	352761029	1,000μF, 35V, Elect.
C902	352752219	220μF, 25V, Elect.
C903	352751019T	100μF, 25V, Elect.
C904	352741029	1,000μF, 16V, Elect.
C905	352742219	220μF, 16V, Elect.
C906	352744709	47μF, 16V, Elect.
C907	352741019	100μF, 16V, Elect.
C908	352744709	47μF, 16V, Elect.
C909	352751019T	100μF, 25V, Elect.
C910	352741009T	10μF, 16V, Elect.
<b>Switches &amp; Terminals</b>		
S601	25065129	NSS-14261, Slide switch
S602 – S605	25035213	NPS-362-122-L177, Push switch
P601	25045020	NPJ-4PDBL11, Input/output terminal
P602	25045057	HLJ-0296-01-510, Mic Jack
P603	25050064	NSCT-5P18, DIN socket

**INDICATOR PC BOARDS**

<b>CIRCUIT NO.</b>	<b>PARTS NO.</b>	<b>DESCRIPTION</b>
PL601	225028	GL9PG59, L.E.D
PL602, PL603	225029	GL9PR9, L.E.D
PL604 – PL606	225028	GL9PG59, L.E.D

**PRINTED CIRCUIT BOARD – PARTS LIST  
REC. AND PLAYBACK AMPLIFIER PC BOARD**

<b>CIRCUIT NO.</b>	<b>PARTS NO.</b>	<b>DESCRIPTION</b>
<b>Transistors</b>		
Q101, Q102	2211405	2SC2240 (GR)
Q103 – Q110	2211255	2SC1815 (GR)
Q601, Q602	2211255	2SC1815 (GR)
Q603	2211454	2SA1015 (Y)
Q901	2201074 or 2201035	2SD880 (Y) or 2SD325 (E)
<b>ICs</b>		
Q604	222460	HA-11226
Q605	222543	LA-4170
<b>Diodes</b>		
D101, D102	223133 or	DS442X or
D105, D106	223105	1S1555
D103, D104	223132	1K60
D107, D108	223132	1K60
D901, D902	223862	WL-01
D903	224123 or 224068	GZA22L or 05Z22L
<b>Coils</b>		
L101, L102	233221	NMC-5021
L103, L104	24606072	NCH-1010
L105, L106	233146	NCH-4021
Z001	24606102	NOB-010
<b>Resistors</b>		
R119, R120	5215023	N08HR50KBC, Semi-fixed
R125, R126	5146024	N16RL50KA35, Input level variable
R155, R156	5215022	N08HR20KBC, Semi-fixed
R183, R184	5215020	N08HR5KBC, Semi-fixed
R189, R190	5215024	N08HR100KBC, Semi-fixed
R606	441525614	560 $\Omega$ , 1/2W, Metal oxide film
R607	441526814	680 $\Omega$ , 1/2W, Metal oxide film
R608	441521214	120 $\Omega$ , 1/2W, Metal oxide film
<b>Capacitors</b>		
C103, C104	352780229T	2.2 $\mu$ F, 50V, Elect.
C109, C110	352734709T	47 $\mu$ F, 10V, Elect.
C111, C112	352741009T	10 $\mu$ F, 16V, Elect.
C115, C116	352750479T	4.7 $\mu$ F, 25V, Elect.
C117, C118	352741009T	10 $\mu$ F, 16V, Elect.
C119, C120	352783399T	0.33 $\mu$ F, 50V, Elect.
C121, C122	352781099T	0.1 $\mu$ F, 50V, Elect.
C123, C124	352741009T	10 $\mu$ F, 16V, Elect.
C125, C126	352783399T	0.33 $\mu$ F, 50V, Elect.
C133, C134	352781099T	0.1 $\mu$ F, 50V, Elect.
C135 – C138	352741009T	10 $\mu$ F, 16V, Elect.
C139, C140	352750479T	4.7 $\mu$ F, 25V, Elect.
C141, C142	352782299T	0.22 $\mu$ F, 50V, Elect.
C149, C150	352761009T	10 $\mu$ F, 35V, Elect.
C151, C152	352750479T	4.7 $\mu$ F, 25V, Elect.
C153, C154	352741009T	10 $\mu$ F, 16V, Elect.
C155, C156	352743309T	33 $\mu$ F, 16V, Elect.
C157, C158	352741009T	10 $\mu$ F, 16V, Elect.
C601	352753309T	33 $\mu$ F, 25V, Elect.
C602	352742219	220 $\mu$ F, 16V, Elect.
C603	352741009T	10 $\mu$ F, 16V, Elect.
C604	352743309T	33 $\mu$ F, 16V, Elect.
C605	352780109T	1 $\mu$ F, 50V, Elect.
C901	352761029	1,000 $\mu$ F, 35V, Elect.
C902	352752219	220 $\mu$ F, 25V, Elect.
C903	352751019T	100 $\mu$ F, 25V, Elect.
C904	352741029	1,000 $\mu$ F, 16V, Elect.
C905	352742219	220 $\mu$ F, 16V, Elect.
C906	352744709	47 $\mu$ F, 16V, Elect.
C907	352741019	100 $\mu$ F, 16V, Elect.
C908	352744709	47 $\mu$ F, 16V, Elect.
C909	352751019T	100 $\mu$ F, 25V, Elect.
<b>Switches &amp; Terminals</b>		
S601	25065129	NSS-14261, Slide switch
S602 – S605	25035213	NPS-362-122-L177, Push switch
P601	25045020	NPJ-4PDBL11, Input/output terminal
P602	25045057	HLJ-0296-01-510, DIN socket

**INDICATOR PC BOARDS**

<b>CIRCUIT NO.</b>	<b>PARTS NO.</b>	<b>DESCRIPTION</b>
PL601	225028	GL9PG59, L.E.D
PL602, PL603	225029	GL9PR9, L.E.D
PL604 – PL606	225028	GL9PG59, L.E.D

## COMPONENT LOCATION

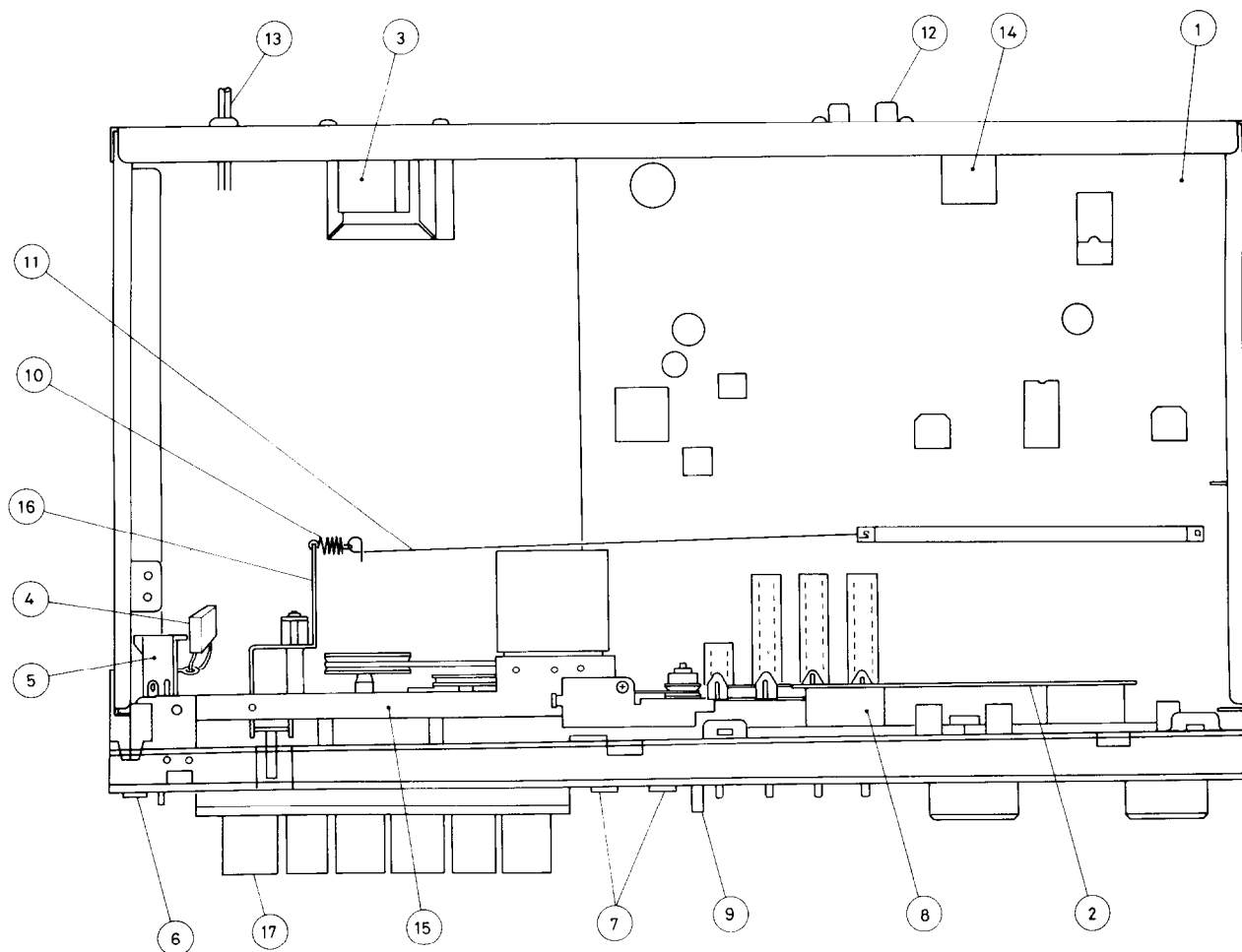

### COMPONENT LOCATION – PARTS LIST

#### D model

#### REF. CIRCUIT

NO.	NO.	PARTS NO.	DESCRIPTION
1	U1	16319505	NAAF-905, Rec./pb amplifier pc board ass'y
2	U5	16319509	NAMTR-909, Meter pc board ass'y
3	T901	230411	NPT-713D, Power transformer
4	C911	3500054	0.01 $\mu$ F, 125V, UL capacitor
5	S901	25035197	NPS-111-L161P, Power switch
6	P604	25045067	HLJ-0279-01-070, Stereo headphone jack
7		25045057	Mic. jack
8	P101, P102	243132	NIND-0300S132, VU meter
		210108	12V, 55mA, Meter illumination lamp
9		28320448	Counter knob
10		27180040	Spring, recording
11		27180061	Spring, recording
12		25045020	Output terminal
13		253099A	AS-UC-3, Power supply cord
		270025	SR-3P-4, Strainrelief
15		244017	NDM-12, Cassette deck ass'y
16		24603152	Lever, recording
17		28320444	Button

#### W/G model

#### REF. CIRCUIT

NO.	NO.	PARTS NO.	DESCRIPTION
1	U1	16322505A	NAAF-905a, Rec./pb amplifier pc board ass'y
2	U5	16319509	NAMTR-909, Meter pc board ass'y
3	T901	230412	NPT-713G, Power transformer (G)
		230413	NPT-713DG, Power transformer (W)
4	C911	3500058	0.01 $\mu$ F, 250V, IS capacitor (G)
	C911, C912	3500058	0.01 $\mu$ F, 250V, IS capacitor (W)
5	S901	25035192	NPS-122-L156P, Power switch (G)
		25035207	NPS-121-L171P, Power switch (W)
6	P604	25045067	HLJ-0279-01-070, Stereo headphone jack
7		25045057	Mic. Jack
8	P101, P102	243132	NIND-0300S132, VU meter
		210108	12V, 55 mA, Meter illumination lamp
9		28320448	Counter knob
10		27180040	Spring, recording
11		27180061	Spring, recording
12		25045020	Output terminal
13		253083	AS-CEE-3, Power supply cord
		270280	SR-4K-4, Strainrelief
14		25050064	DIN socket
15		244017	NDM-12, Cassette deck ass'y
16		24603152	Lever, recording
17		28320444	Button
		25065123	NSS-1258P, Voltage selector (W)

(G) : Only 220V model

(W) : Only 120/220V model

## PACKING PROCEDURES

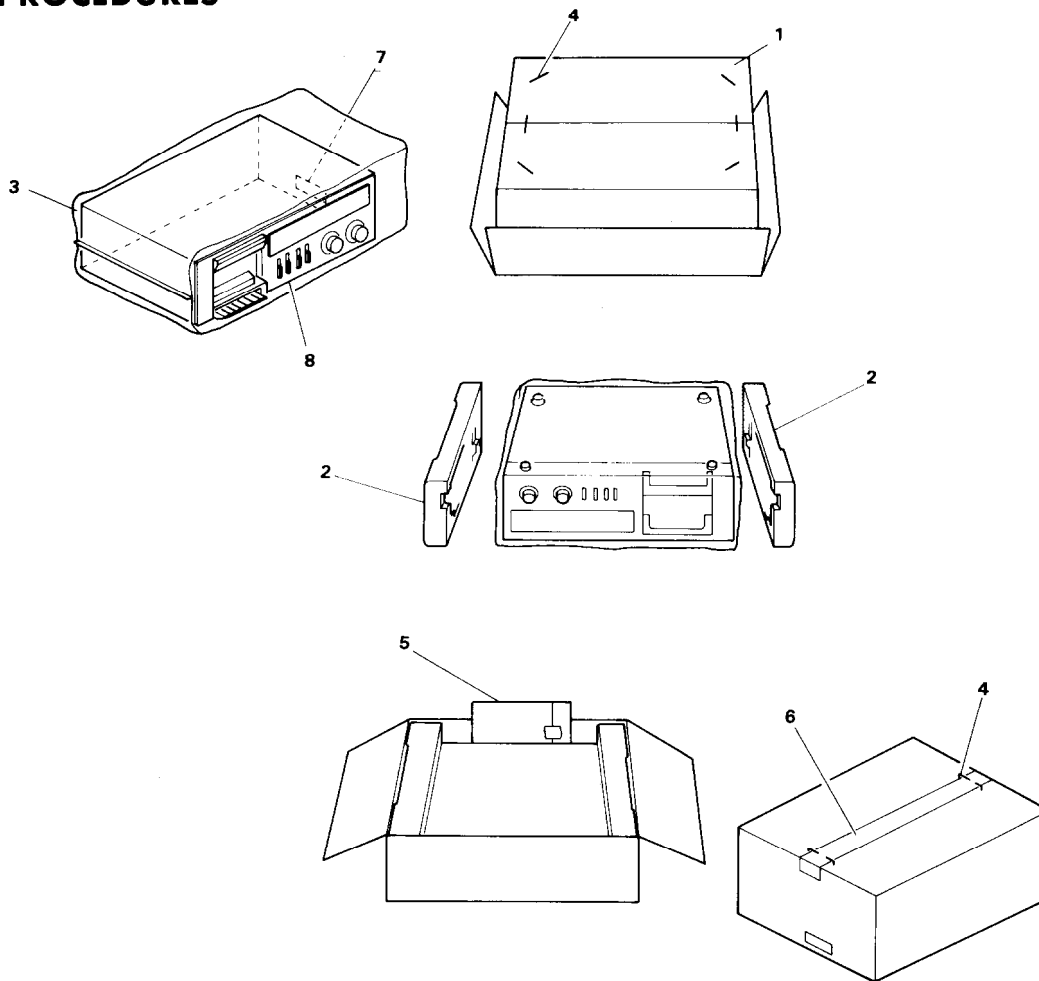

### PACKING PROCEDURES – PARTS LIST

#### D model

REF. NO.	PARTS NO.	DESCRIPTION
1	29050383	Master carton box
2	29090535	Pad
3	29100037	650 x 500 mm, Poly bag
4	282301	Sealing hook
5	29358002	Service station list
	29340445	Instruction manual
	29365006	Warranty card
	253074	Connection cable
	29100005	330 x 220 mm, Poly bag
6	260012	50 x 150 mm, Tape
7	29360298	Label
8	293041	Caution label

#### G/W model

REF. NO.	PARTS NO.	DESCRIPTION
1	29050383	Master carton box
2	29090535	Pad
3	29100037	650 x 500 mm, Poly bag
4	282301	Sealing hook
5	29340446	Instruction manual
	29365005-3	Warranty card (G)
	253074	Connection cable
	25055018	CV-K-1, Conversion plug (W)
	29100005	330 x 220 mm, Poly bag
6	260012	50 x 300 mm, Tape

(G) : Only Germany model

(W) : Only W model

### ONKYO CORPORATION

International Division : No. 24 Mori Bldg., 23-5, 3-chome, Nishi-Shinbashi, Minato-ku, Tokyo Japan  
Telex : 2423551 ONKYO J. Phone : 03-432-6981

### ONKYO U.S.A. CORPORATION

#### Eastern Office

42-07 20th Avenue, Long Island City, New York 11105, U.S.A. Phone : (212) 728-4639

#### Midwest Office

935 Sivert Drive, Wooddale, Illinois 60191, U.S.A. Phone : (312) 595-2970

C/O Damark Industries Inc.

20520 Nordhoff Chatsworth, Cal. 91311, U.S.A. Phone : (213) 998-6501

### ONKYO DEUTSCHLAND GMBH, ELECTRONICS

8034 München-Germering, Industriestrasse 18, West Germany. Telex : 521726 Telefon : (089)-845-5041