

ONKYO. SERVICE MANUAL

STEREO CASSETTE TAPE DECK Model TA-2010

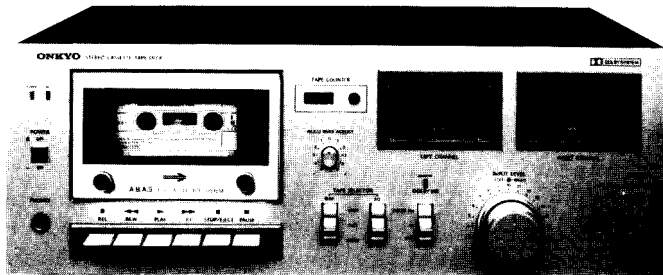

TABLE OF CONTENTS

Item	Page
Specifications	2
Voltage conversion	2
Mechanism operation	3
Exploded view	4
Component location	5
Alignment procedures	6
Service procedures	8
Mechanism-exploded view	9
Schematic diagram	11
Printed circuit board view	13
PC board-parts list	14
Block diagram	15
Features	15
Packing procedures	16

ONKYO.
AUDIO COMPONENTS

SPECIFICATIONS

Track System: 4-track, 2-channel stereo
 Recording System: AC bias
 Erasing System: AC erase
 Tape Speed: 4.8 cm/sec.
 Wow and Flutter: 0.08% (WRMS)
 Frequency Response: 20 ~ 14,000 Hz (Normal)
 20 ~ 16,000 Hz (FeCr)
 20 ~ 16,000 Hz (High)
 Signal-to-Noise Ratio: Dolby NR out, FeCr tape: 54 dB
 A noise reduction of 10 dB above 5 kHz and 5 dB at 1 kHz is possible with the Dolby NR in.
 Input Jacks: Microphone Jacks: 2
 Minimum input level: 0.3 mV
 Input impedance: 5 kΩ
 Optimum mic impedance: 200Ω ~ 50 kΩ
 Line in Jacks: 2
 Minimum input level: 50mV
 Input impedance: 50 kΩ

Outputs: LINE: 2 HEADPHONES: 1
 LINE: Output level 0.480V (at 0 VU)
 impedance over 50 kΩ
 HEADPHONE: 8Ω/200Ω
 Motor: DC servo-motor
 Heads: Hard Permalloy Heads
 Components: TR: 15 Diodes: 11 IC: 2
 LED: 3
 Power Supply: AC 120V 60 Hz (U.S.A. model)
 AC 110/120/220/240V 50/60Hz (Universal model)
 Power Consumption: 8.5 W
 Dimensions: 418(W) × 150(H) × 250(D) mm
 16-7/16" × 5-5/16" × 9-13/16"
 Weight: 4.8 kg. (10.6 lbs.)
 Accessories: Pin-type connecting cords: 2

* Specifications and external appearance are subject to change without prior notice because of product improvements.

Current consumption (motor)

Playback: 65 – 100 mA
 Recording: 65 – 100 mA
 Fast forward: 65 – 90 mA
 Rewind: 65 – 80 mA
 Auto-Stop
 Playback-Stop: 140 – 160 mA

Mechanism specifications

- 1) Tape speed: 4.8 cm/sec. (3 kHz +3%, -2%)
 Use a standard test tape, VTT-658 (3 kHz) or equipment.
- 2) Wow and Flutter: Less than 0.08% (WRMS)
- 3) Take-up torque: 35 – 70 gr-cm
- 4) F.F. torque: 55 – 130 gr-cm
- 5) Rewind torque: 55 – 130 gr-cm
- 6) Rewind time: Less than 110 sec. (use a C-60 cassette tape)
- 7) Automatic shut-off time: Less than 5 sec.

VOLTAGE CONVERSION (Universal model)

This model is equipped with a universal power transformer to permit operation at either power source of 110, 120, 220 or 240V AC 50/60Hz.

To convert the unit to a different power source voltage, change the plug as illustrated in the drawing below.

CAUTION: DISCONNECT POWER SUPPLY CORD FROM AC OUTLET BEFORE CONVERTING VOLTAGE.

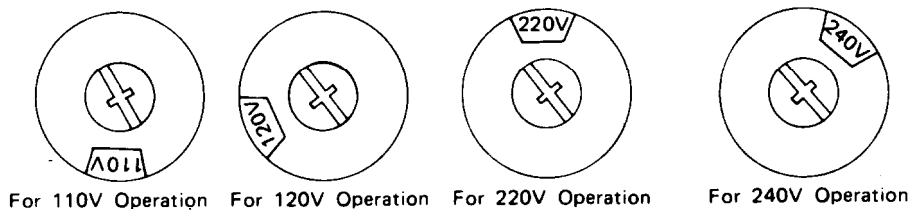
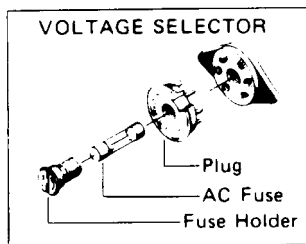

MECHANISM OPERATION

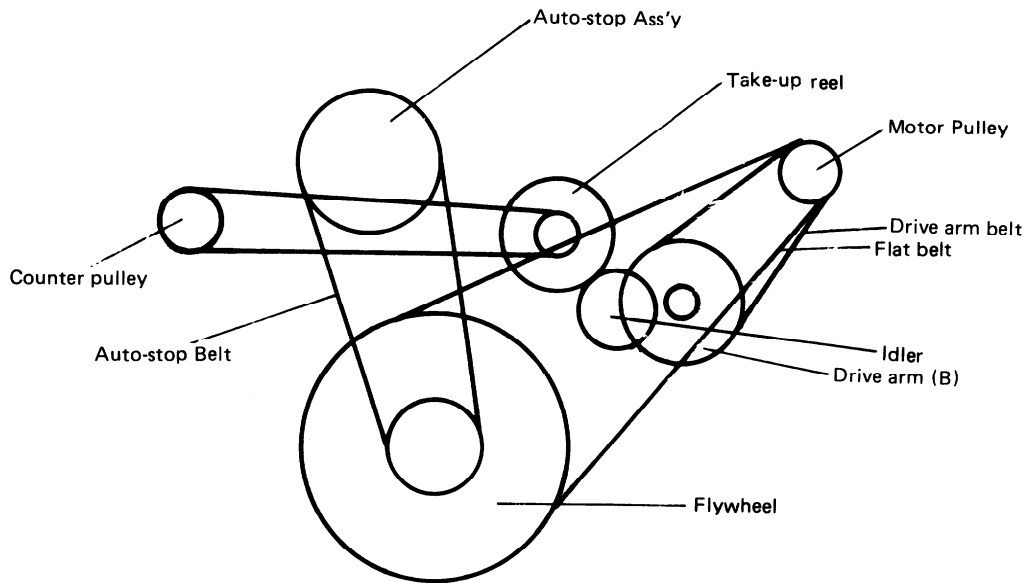

1. Play operation

Upon pressing the PLAY button, the head chassis shifts upward, and the idler which is linked to the chassis engages the drive arm AS-B and take-up reel to drive the take-up reel. During play, the rotation torque is determined by a slip mechanism which consists of a felt pad inside the reel platform.

2. Fast forward operation

Upon pressing the FF button, the drive arm AS-B moves to its right, and the gear on the drive arm AS-B engages the idler gear. Since the idler gear is constantly engaged with the gear on the take-up reel platform, this drives the take-up reel platform. During fast forward, the rotation torque is determined by a slip mechanism which consists of a felt pad inside the drive arm AS-B.

3. Rewind operation

Upon pressing the REW button, the drive arm AS-B moves to its left, and the gear on the drive arm AS-B

engages the gear on the supply reel platform to drive the supply reel. During rewind, the rotation torque is determined by a slip mechanism which consists of a felt pad inside the drive arm AS-B.

4. Pause operation

Upon pressing the PAUSE button, the pinch roller lever is moved by the pause lever and disengaged from the capstan, and at the same time the idler pulley is disengaged from the take-up reel platform and drive arm AS-B.

5. Auto-stop operation

When the tape winds to its end and reel platform rotation halts, the sensor connected to the reel platform stops in a vertical position. Since the worm gear is rotating, the hook of the stopped sensor and the worm gear make contact, and then the sensor is pushed downward. Next, the stop lever is pushed downward by the sensor to operate the lock-plate and disengage the buttons.

MECHANISM-EXPLODED VIEW

PARTS LIST

REF. NO.	PARTS NO.	DESCRIPTION
1	24610202	Chassis
2	24603094	Recording lever
3	24603095	Rewind lever
4	24603096	Play lever
5	24603097	Fast forward lever
6	24603098	Stop/eject lever
7	24603099	Pause lever
8	24610203	Fixture plate, lever
9	24610204	Switch plate
10	24605125	Spring for 2, 3, 4 & 5
11	24605126	Spring for 6 & 7
12	24610205	Collar (F)
13	24603073	Lock plate
14	24605127	Spring for 13
15	24603100	Cancellation lever (F)
16	24605128	Spring for 15
17	24603101	Latch lever
18	24610206	Stop plate
19	24605129	Spring for 18
20	24610207	Idler ass'y
21	24605130	Spring for 20
22	24610208	Pause support plate
23	24610209	Fast forward collar
24	24610210	Switch plate
25	24605131	Plate spring
26	24610211	Drive arm (B)
27	24605132	Spring for 26
28	24605133	Spring for 26
29	24610212	Sensor
30	24610213	Auto-stop ass'y
31	24605134	Spring, pause
32	24602047	Flywheel
33	24605135	Spring for 32
34		Chassis, flywheel
35-1	24610216	Head chassis
35-2	24600011	Rec./pb head
35-3	24600012	Erase head
35-4	24605136	Spring for 35-2
35-5	800005	2.5 x 5 x 0.2, Eyelet
35-6	801198	M2 x 12, Screw
35-7	83812008	M2 x 8, Screw
36	28320331	Button
37	28320329	Rec. button
38	28320330	Stop/eject button
39	24604030	Button shaft
40	24605137	Spring for 39
41	24602048	Counter belt
42	24610217	Mechanism cover plate
43	24610218	Cylinder
44	24610219	Cassette case
45	24610220	Stopper
46	24610221	Bracket, tape mechanism
50	24601036	Motor
50-1	25610222	Bracket, motor
50-2	801176	+2.6 x 4, Screw
50-3	24601037	Motor pulley
50-4	801183	M2 x 4, Screw
51-1	24610223	Bracket switch
51-2	24606075	Slide switch
51-3	83312606	M2.6 x 6, Screw
51-4	24605138	Spring for 51-2
52	24602049	Idler gear
53	24602050	Supply reel
54	24605139	Spring for 53
55	24602051	Take-up reel
56	24605140	Spring for 55
57	24610224	Clutch plate
58	24610225	Pinch roller
59	24605141	Spring for 58
60	24610201	Lock plate
61	24605142	Spring for 44
62	24606084	Switch
63	24605143	Spring for 17
65	834126082	M2.6 x 8, Screw
66	834126062	M2.6 x 6, Screw
67	831126062	M2.6 x 6, Screw
68	831130062	M3 x 6, Screw
69	838126044	M2.6 x 4, Screw
70	833120068	M2 x 6, Screw
71	833126108	M2.6 x 10, Screw
72	833126068	M2.6 x 6, Screw
73	833130068	M3 x 6, Screw
74	24610134	1.6 x 4, Mylar washer
75	24610226	2.2 x 5, Mylar washer
76	24610227	1.5 x 4, Mylar washer
77	24610228	5.2 x 12, Mylar washer
78	24610229	2.1 x 10, Poly slider washer
79	24610230	Washer
80	24602052	Flat belt
81	24602053	Drive arm belt
82	24602054	Auto-stop belt

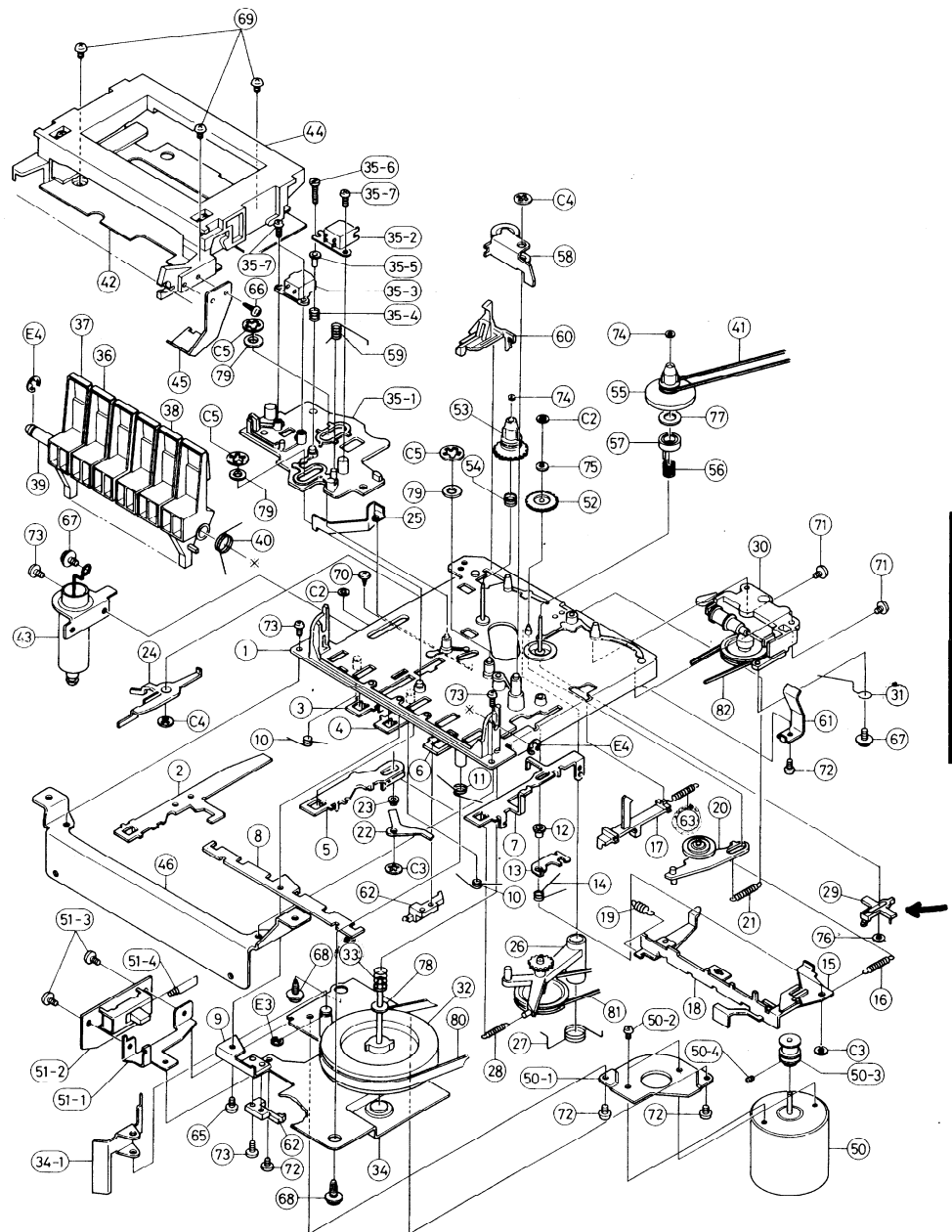

REF. NO.	PARTS NO.	DESCRIPTION
E4	893040	E-4, Circlip
C2	890006	CS2, Retaining clip
C3	890007	CS3, Retaining clip
C4	890008	CS4, Retaining clip
C5	890009	CS5, Retaining clip

TA-2010D
TA-2010D

9

10

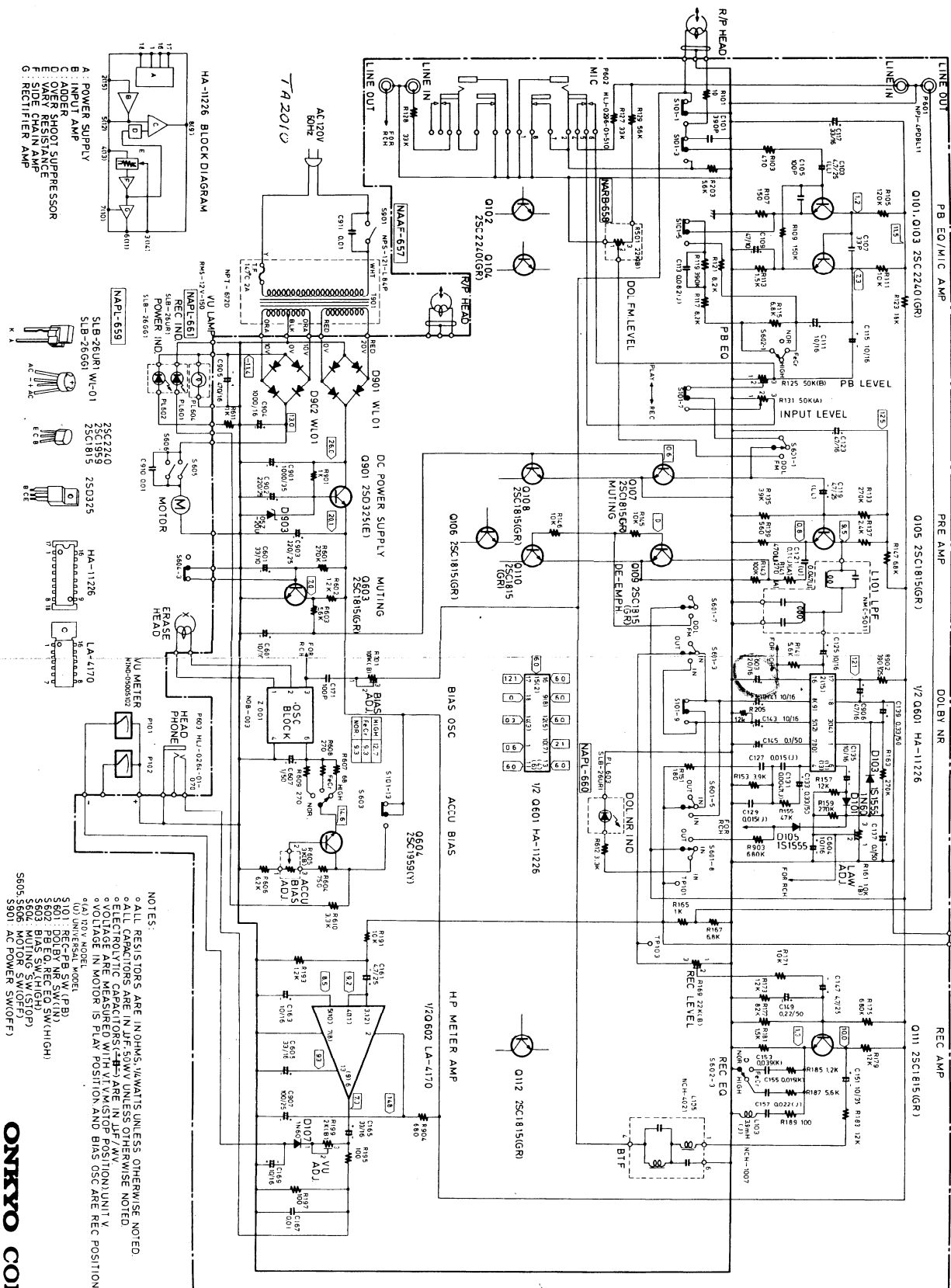

EXPLODED VIEW

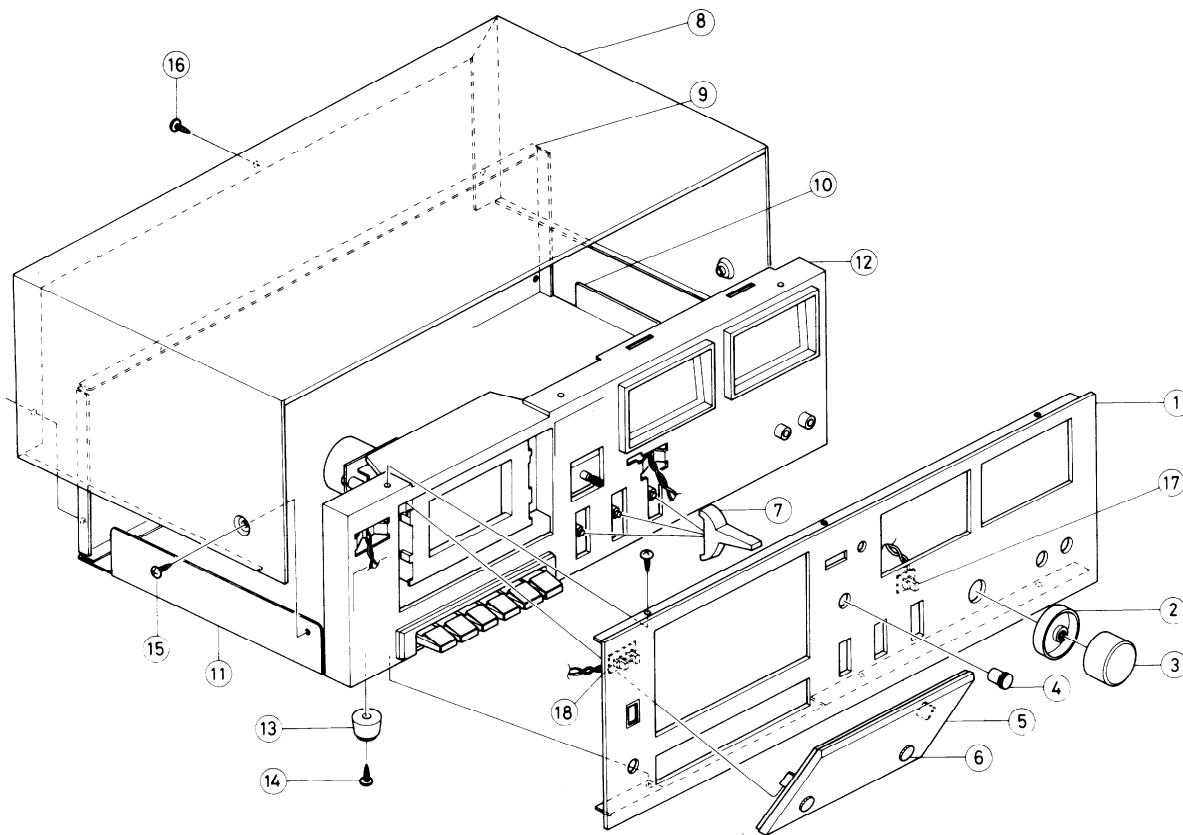

EXPLODED VIEW – PARTS LIST

120V model

REF. NO.	PARTS NO.	DESCRIPTION
1	27210125	Front panel
2	28320321	Knob (L)
3	28320320	Knob (R)
4	28320290	Knob, accu.
5	27300207	Glass
	GLASS → 27300208	Cassette door
6	801196	Decoration screw
	27270036	Spacer
	870052	Washer
	800129	Nut
7	28320322	Knob, lever
8	28184053	Top cover
9	27120163	Back panel
10,11	27170056A	Bottom board
12	27110081	Front bracket
13	27175009	Leg
14	831130162	3STW+16BQ, Tapping screw
15	833140087	4TTP+8S, Tap screw
16	834430062	3STS+6BQ(BC), Tapping screw
17	16419560	NAPL-660, Dolby indicator pc board complete
18	16419559	NAPL-659, Rec./power indicator pc board complete

244010 NDM TRANSPORT

243102 NIND-0500S102 METER

Universal model

REF. NO.	PARTS NO.	DESCRIPTION
1	27210125	Front panel
2	28320321	Knob (L)
3	28320320	Knob (R)
4	28320290	Knob, accu.
5	27300207	Glass
	27300208	Cassette door
6	801196	Decoration screw
	27270036	Spacer
	870052	Washer
	800129	Nut
7	28320322	Knob, lever
8	28184053	Top cover
9	27120168	Back panel
10,11	27170056A	Bottom board
12	27110081	Front bracket
13	27175009	Leg
14	831130162	3STW+16BQ, Tapping screw
15	833140087	4TTP+8S, Tap screw
16	834430062	3STS+6BQ(BC), Tapping screw
17	16419560	NAPL-660, Dolby indicator pc board complete
18	16419559	NAPL-659, Rec./power indicator pc board complete

COMPONENT LOCATION

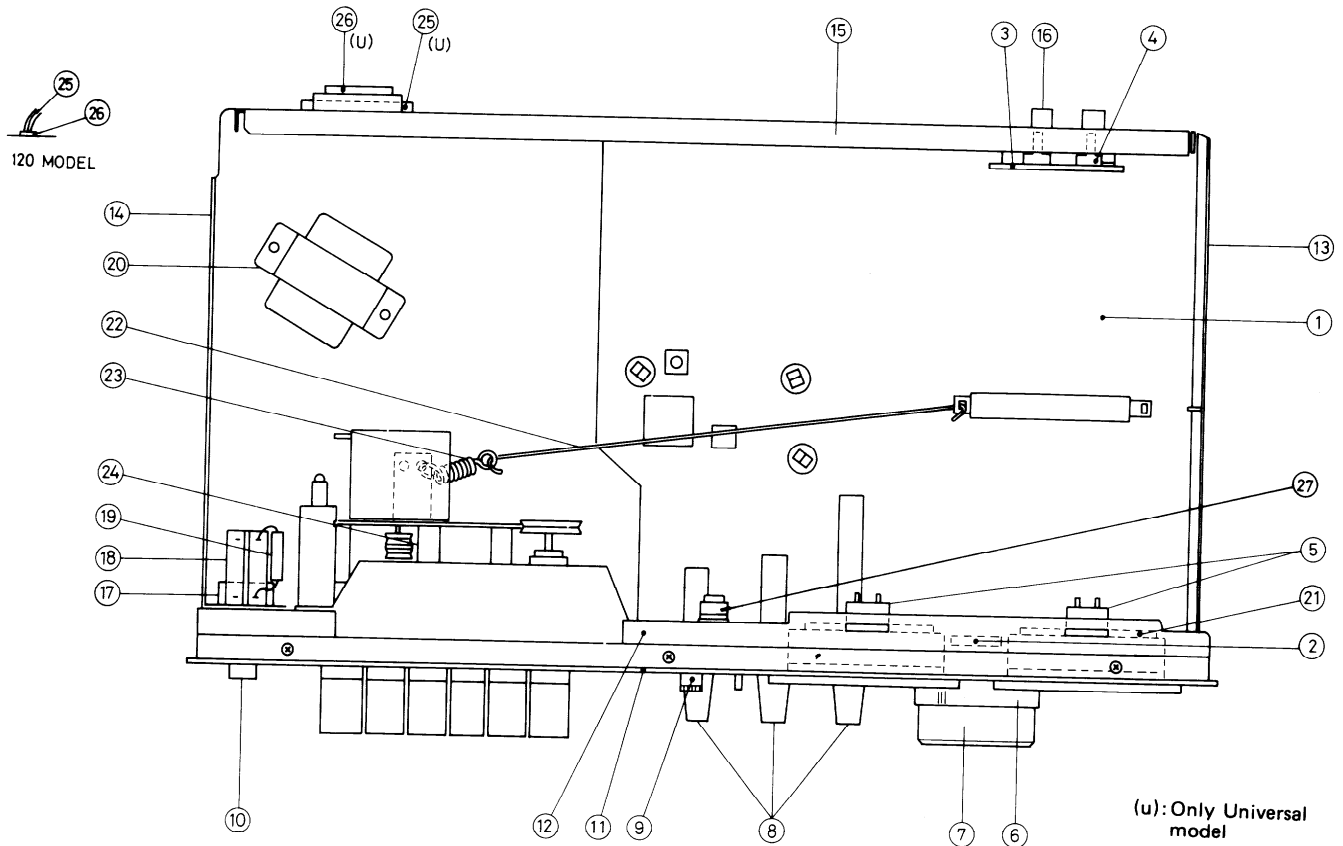

COMPONENT LOCATION – PARTS LIST

120V model

REF. NO.	CIRCUIT NO.	PARTS NO.	DESCRIPTION
1	U1	16419557	NAAF-657, Rec/pb amplifier pc board complete
2	U5	16419561	NAPL-661, Meter illumination pc board complete
3	U2	16419558	NARB-658, Dolby FM pc board complete
4	R501,R502	5225101	N10HR22KBD, Dolby FM level adjustment semi-fixed resistor
5	P101,P102	243102	NIND-0500S102, VU meter
6		28320320	Knob (R)
7		28320321	Knob (L)
8		28320322	Knob, lever
9		28320290	Knob, volume
	R605	5146012	N16RC3KB15, Bias adjustment variable resistor
10			Power knob ass'y
		27267048	Power switch guide
		28320319	Power switch knob
		27180038	Spring
11		16419121	Front panel
12		27110081	Front bracket
13,14		27170056A	Bottom board
15		27120163	Back panel
16	P601	25045020	NPJ-4PDBL-11, Input/output terminal
17	P603	25045046	HLJ0264-01-070, Stereo headphone jack
18	S901	25035119	NPS-121-L84, Power switch
19	C911	3504012	UL125V103M, UL capacitor
20	T901	230293	NPT-672D, Power transformer
21		27130151	Bracket, meter
22		27180039	Spring
23		27180040	Spring
24	Z001	244010	NDM-05, Tape deck mechanism ass'y
25		253099	AS-UC3, Power supply cord
26		270025	SR-3P4, Strainrelief
27		24601022	Counter

Universal model

REF. NO.	CIRCUIT NO.	PARTS NO.	DESCRIPTION
1	U1	16420557A	NAAF-657A, Rec/pb amplifier pc board complete
2	U5	16419561	NAPL-661, Meter illumination pc board complete
3	U2	16419558	NARB-658, Dolby FM pc board complete
4	R501,R502	5225101	N10HR22KBD, Dolby FM level adjustment semi-fixed resistor
5	P101,P102	243102	NIND-0500S102, VU meter
6		28320320	Knob (R)
7		28320321	Knob (L)
8		28320322	Knob, lever
9		28320290	Knob, volume
	R605	5146012	N16RC3KB15, Bias adjustment variable resistor
10			Power knob ass'y
		27267048	Power switch guide
		28320319	Power switch knob
		27180038	Spring
11		16419121	Front panel
12		27110081	Front bracket
13,14		27170056A	Bottom board
15		27120168	Back panel
16	P601	25045020	NPJ-4PDBL-11, Input/output terminal
17	P603	25045046	HLJ0264-01-070, Stereo headphone jack
18	S901	25035034	NPS-121-L, Power switch
19	C911,C912	3500052	PME 271Y510CEE, IS capacitor
20	T901	230295	NPT-672ADGQ, Power transformer
21		27130151	Bracket, meter
22		27180039	Spring
23		27180040	Spring
24	Z001	244010	NDM-05, Tape deck mechanism ass'y
25		25050018	3P Inlet
26		25050021	X-17240, Voltage selector
		252016	0.3A-T, Fuse
27		24601022	Counter

ELECTRICAL ADJUSTMENT PROCEDURES

PRECAUTIONS

1. Tape required:

- (1) Blank tape

MAXELL	UD-XL/I	(Normal)
	UD-XL/II	(CrO2)
SONY	Duad	(FeCr)

- (2) Test tape

VICTOR	VTT-658	10 kHz, -15 dB
TEAC	MTT-111	3 kHz, -10 dB
	MTT-150	Dolby level calibration tone.

2. Instrument required:

- (1) AC VTVM
- (2) Frequency counter
- (3) AF oscillator
- (4) Attenuator

1. PLAYBACK MODE ADJUSTMENT

1-1. Head azimuth adjustment

PROCEDURES:

- 1) Play the 10 kHz portion of the test tape VTT-658 back. Adjust the head azimuth adjusting screw for maximum V.T.V.M. read.
- 2) If the peak output reads of the right and left channels are different, set the screw to obtain the mechanical center between the peaks.
- 3) After adjustment, lock the screw with bond.

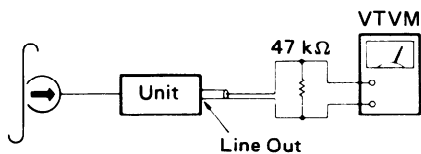

1-2. Tape speed adjustment

PROCEDURES:

Play the 3 kHz portion of the test tape MTT-111 back. Adjust the tape speed adjusting semi-fixed resistor in the motor for 3,000 to 3,010 Hz counter indication.

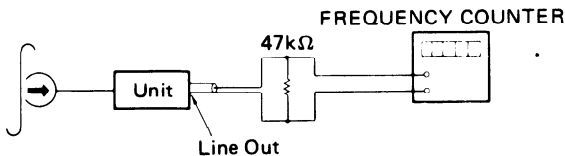

1-3. Playback output adjustment

PROCEDURES:

- 1) Play the test tape MTT-150 back, adjust R125 and R126 for 775 mV V.T.V. M. read.
- 2) Proceed both for the left and right channels in the same manner.

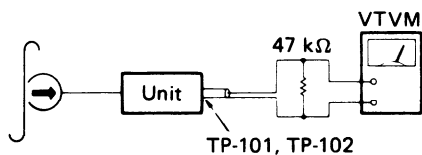

3. The switches and controls should be set as follows unless otherwise specified.

Tape selector bias switch:	Normal
Tape selector equalizer switch:	Normal
Dolby NR switch:	Out

1-4. VU meter adjustment

PROCEDURES:

- 1) Play the test tape MTT-150 back.
- 2) Adjust R199 and R200 until the VU meter pointer deflects to the Dolby mark (∞, +3dB) on the meter.

2. RECORDING MODE ADJUSTMENT

2-1. Dolby circuit adjustment

PROCEDURES:

- 1) Connect the 5 kHz, 10mV input signal to the line in terminal.
- 2) Connect the VTVM to the TP-103 terminal.
- 3) Set the tape deck in the recording mode of operation.
- 4) Adjust the input level volume for 23.5mV VTVM read.
- 5) Turn the Dolby NR (MPX Filter) switch to ON.
- 6) Adjust R161 for 60mV VTVM read.

2-2. Record bias adjustment

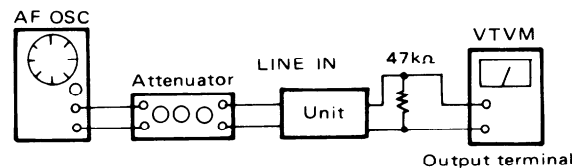

- 1) Press the pause key, and put the tape deck into recording mode. Apply a 400Hz signal to the Line input terminals, and adjust the AF oscillator output so that the VU meter reads 0VU.
- 2) Then set the input level to -20dB, and release the pause switch to record on the tape. Read the output level when this recording is played back again.
- 3) Next change the frequency of the oscillator to 8kHz, and record again as described above. During playback of this recording, obtain the same output level as with the 400Hz recording by readjusting R201 and R202.

- 4) Adjust the attenuator for 0.775mV VTVM read.
- 5) Set the deck in the playback mode of operation.
- 6) Adjust the R169 and R170 for $\pm 0.7\text{dBm}$ (0.718V -0.837V) VTVM read.

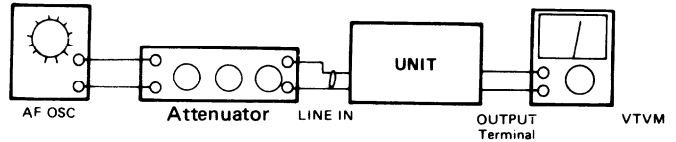

2-3. Record-playback output level adjustment

PROCEDURES:

- 1) Connect the 1 kHz input signal to the line in terminal.
- 2) Connect the VTVM to the output terminal.
- 3) Set the tape deck in the recording mode of operation.

3. DOLBY FM LEVEL ADJUSTMENT

- 1) Set the input selector switch to the DOLBY FM.
- 2) Connect the AF oscillator to the line input terminal and the AC VTVM to the line output terminal.
- 3) Set the AF oscillator to 400Hz, 250mV.
- 4) Adjust the output voltage to 1.1V with R501 and R502 on the back panel.

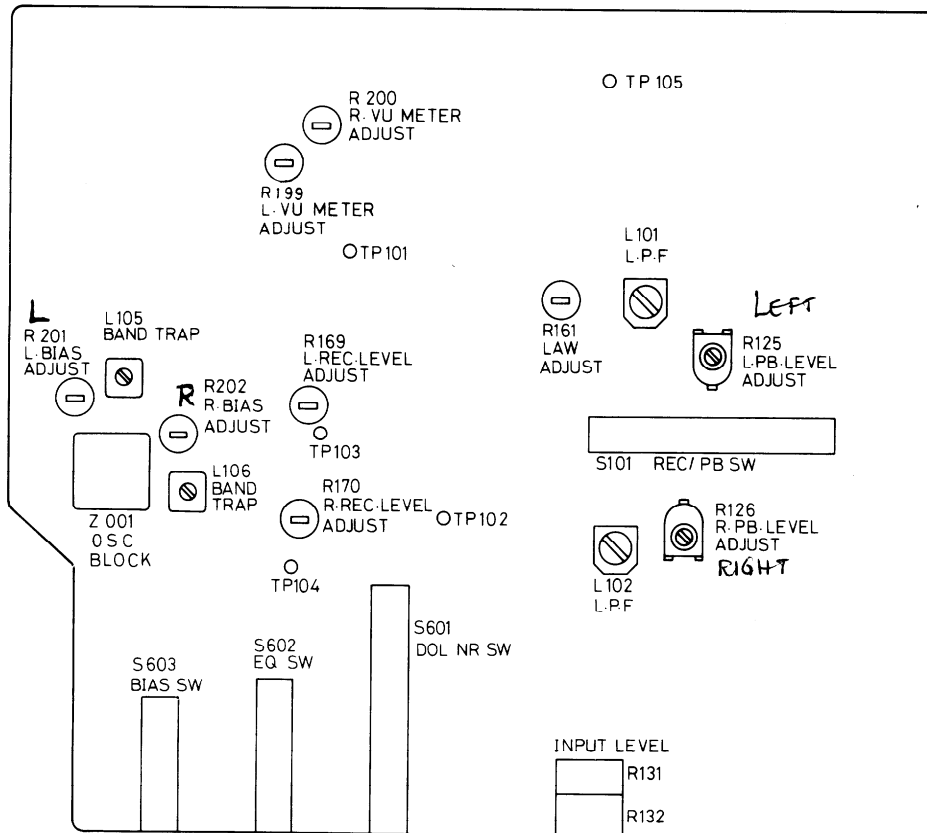

SERVICE PROCEDURES

1. Removal the cassette door

Press the STOP/EJECT key to open the cassette door, then lift the door up and out to remove as illustrated below.

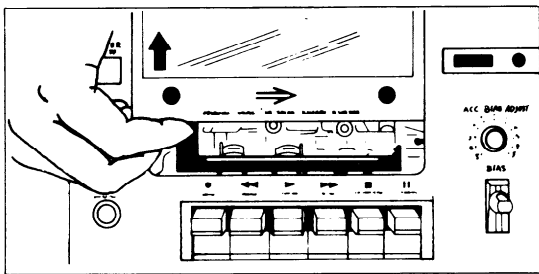

2. Removal the front panel

Remove four screws which hold the top cover to side bracket and lift the top cover up. Pull out the input, and adjust knobs.

Pull out three lever knobs. Remove six screws which hold the front panel to the front bracket.

3. Replacement of pinch roller assembly

- * Remove the pinch roller spring.
- * Remove the retaining clip which serves to secure the pinch roller.
- * When removing the retaining clip, cut it with a pair of nippers.
- * Therefore, once the retaining clip has been removed, it cannot be re-used, so please attach a new one when re-assembling.

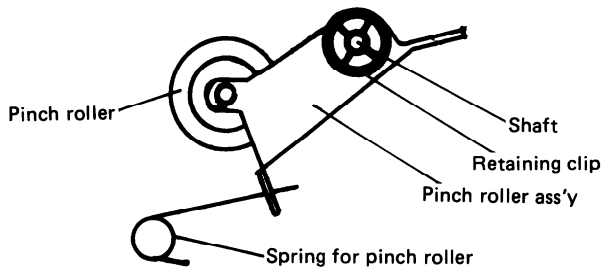

4. Replacement of motor

Set the flat belt and square belt located on the motor pulley to the belt hanger which is located just in front of the pulley, and take out the 2 motor attachment screws. How the motor can be removed.

5. Replacement of belt

Set the 2 belts from the motor pulley onto the belt hanger. Then remove the 3 angle attachment screws. Then replace with new belts.

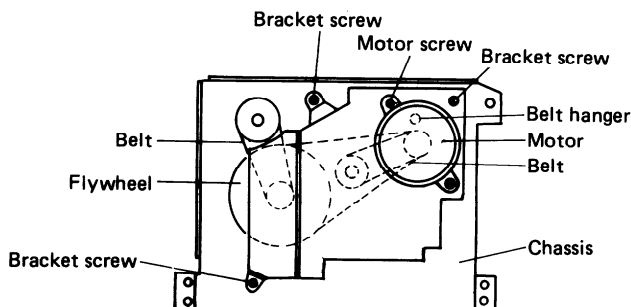

6. Replacement of reel platform

Remove the mechanism cover plate and take off the nylon washer from the reel platform spindle. Then replace the reel platform. Use a new nylon washer when re-inserting the reel platform.

7. Adjustment of the eject mechanism

The speed of the opening and closing action of the cassette compartment can be controlled by the adjustment screw at the rear of the cylinder as shown in the graph. By turning the screw to the left, speed becomes faster, and to the right, slower.

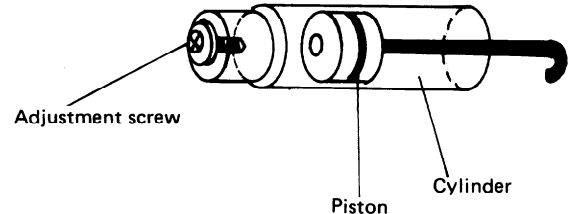

8. Cleaning and Demagnetizing

Head Cleaning

Sound quality is greatly influenced by accumulation of magnetic particles on the recording/playback head.

For clearest possible sound, be sure to clean the head periodically, normally 2 ~ 3 times a month.

A dirty head will cause:

- * Poor sound quality (loss of high sounds)
- * Decrease volume
- * Skipping
- * Poor erasing (incomplete erasure of previous recording)

To prevent these problems, clean the head and capstan shaft with a cleaning pen or a cotton swab dipped in a little alcohol.

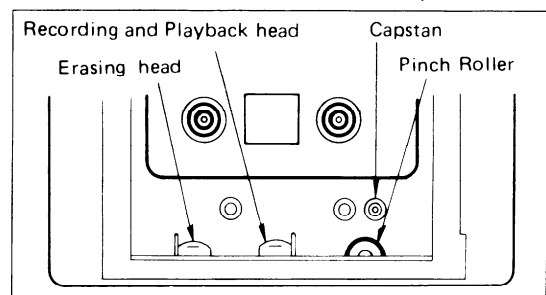

Pinch Roller Cleaning

If the pinch roller is dirty, the tape may become tangled and damaged by wrapping around the roller. Clean the pinch roller when cleaning the head. Use a special cleaner and cotton swab. Head cleaning materials must never be used for the pinch roller.

Demagnetizing

Residual magnetism builds up in the head after the cassette deck has been used for a long period. This build-up introduces noise and static into recording tapes and lowers the high frequency range. To prevent this, demagnetize the erasing and recording/playback heads, as well as other affected metal parts (like the capstan shaft) once every 50 hours of use. Keep tape deck Power OFF while using the demagnetizer. Also place recording tapes far away from the work area.

PC BOARD — PARTS LIST

REC., AND PLAYBACK PC BOARD (NAAF-657) — PARTS LIST

CIRCUIT NO.	PARTS NO.	DESCRIPTION
	ICs	
Q601	222460	HA-11226
Q602	222543	LA-4170
	Transistors	
Q101-Q104	2211405	2SC2240(GR)
Q105-Q112	2211255	2SC1815(GR)
Q603	2211255	2SC1815(GR)
Q604	2211544	2SC1959(Y)
Q901	2201035	2SD325(E)
	Diodes	
D101,D102	223103	1N60
D103-D106	223105	1S1555
D107,D108	223103	1N60
D901,D902	223862	WL01
D903	224067	05Z20U
	Coils	
L101,L102	233145	NMC-5011
L103,L104	24606069	NCH-1007
L105,L106	233146	NCH-4021
	Oscillator block	
Z001	24606078A	NOB-003
	Resistors	
R125,R126	5225058	N10HR50KBC, Semi-fixed
R131,R132	5104081	N16RKL50KA30F, Input level control variable
R161	5225015	N10HR10KBD, Semi-fixed
R169,R170	5225032	N10HR22KBD, Semi-fixed
R199,R200	5225005	N10HR2.2KBD, Semi-fixed
R201, R202	5225016	N10HR100KBD, Semi-fixed
	Capacitors	
C103,C104	392850477	4.7 μ F, 25V, LL
C109,C110	352734701	47 μ F, 10V, Elect.
C111,C112	352741001	10 μ F, 16V, Elect.
C115,C116	352741001	10 μ F, 16V, Elect.
C117,C118	352743301	33 μ F, 16V, Elect.
C119,C120	392850477	4.7 μ F, 25V, LL
C123,C124	352744701	47 μ F, 16V, Elect.
C125,C126	352741001	10 μ F, 16V, Elect.
C133,C134	392883397	0.33 μ F, 50V, LL
C135,C136	352741001	10 μ F, 16V, Elect.
C137,C138	392881097	0.1 μ F, 50V, LL
C139,C140	392883397	0.33 μ F, 50V, LL
C141,C142	352741001	10 μ F, 16V, Elect.
C143,C144	352741001	10 μ F, 16V, Elect.
C145,C146	392881097	0.1 μ F, 50V, LL
C147,C148	352750471	4.7 μ F, 25V, Elect.
C149,C150	392882297	0.22 μ F, 50V, LL
C151,C152	352761001	10 μ F, 35V, Elect.
C161,C162	352750471	4.7 μ F, 25V, Elect.
C163,C164	352741001	10 μ F, 16V, Elect.
C165,C166	352743301	33 μ F, 16V, Elect.
C169,C170	352741001	10 μ F, 16V, Elect.
C601	352743301	33 μ F, 16V, Elect.
C602	352741001	10 μ F, 16V, Elect.
C603	352732211	220 μ F, 10V, Elect.
C604	352741001	10 μ F, 16V, Elect.
C605	352743301	33 μ F, 16V, Elect.
C607	352780101	1 μ F, 50V, Elect.
C901	352761021	1,000 μ F, 35V, Elect.
C902,C903	352752211	220 μ F, 25V, Elect.
C904	352741021	1,000 μ F, 16V, Elect.
C905	352744711	470 μ F, 16V, Elect.
C906	352744701	47 μ F, 16V, Elect.
C907	352751011	100 μ F, 25V, Elect.
	Switches	
S101	25065086	NSS-12347, Rec./Pb. selector switch
S601	25040059	NLS-183-1515-L33, Dolby selector
S602	25040060	NLS-143-1515-L34, Equalizer selector
S603	25040061	NLS-123-1515-L35, Bias current selector
	Terminal	
P601	25045020	NPJ-4PDBL11, Input/Output
	Mic. jack	
P602	25045057	HLJ-0296-01-510
R501,R502	5225101	N10HR22KBD, Semi-fixed resistor
PL601	225032	SLB-26UR1, L.E.D.
PL602	225033	SLB-26GG1, L.E.D.
PL603	225032	SLB-26UR1, L.E.D.
PL604	210065	PL12V150mA, Pilot lamp

BLOCK DIAGRAM

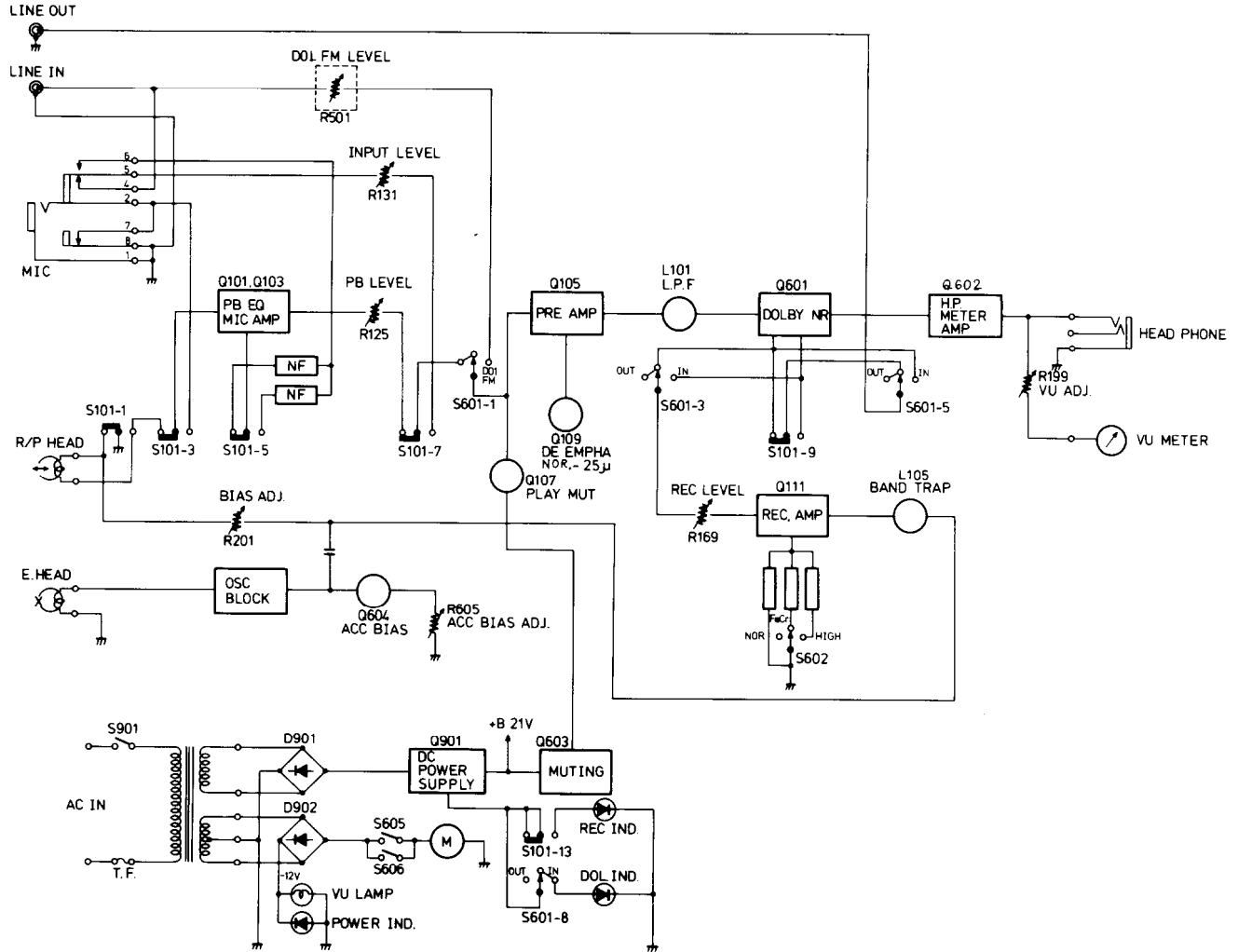

FEATURES

Super Hard Permalloy Head (WIDEX HEAD)

The TA-2010 uses a WIDEX HEAD, which features both a core and case constructed out of Super Hard Permalloy. Because this type head has ten times the abrasion resistance of Permalloy heads of the past, it maintains high performance over many years of use. The WIDEX HEAD is also completely shielded from magnetic interference.

for each tape type. Accu-Bias goes beyond conventional tape selectors to find the accurate bias for each type of tape you use.

Dolby Noise Reduction System

Equipped with a built in Dolby NR System which reduces tape hiss to a minimum, the TA-2010 has a tape selector lever with three positions which allows for maximum noise reduction no matter what kind of tape is being used.

Built-in Dolby FM Decoder

With the TA-2010 you will be right up to date for recording and listening with the increasingly popular Dolby FM broadcasts. No need for an extra adaptor or a new tuner/receiver especially designed for Dolby FM. The improved S/N ratio makes noise practically non-existent and results in greatly improved output levels at high frequencies.

Separate 3-Way Bias and Equalization Selectors

The TA-2010 is designed to handle all major types of cassette tapes available on the market today. And in combination with the Accu-Bias control, optimum bias levels are assured for every tape used.

Full Auto-Stop Mechanism

Full automatic stop at the end of the tape safeguards both tapes and tape transport from undue strain.

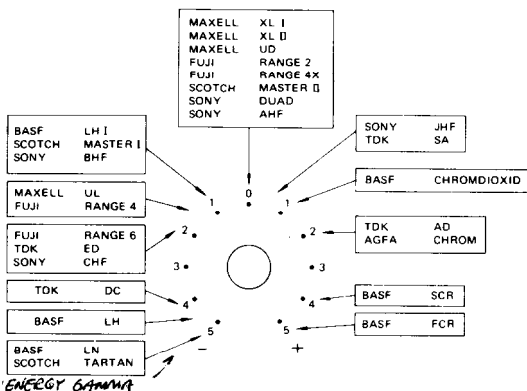

Accu-Bias Adjust System

The amount of bias current applied to the tape during recording has a great effect on frequency response, not to mention distortion and signal-to-noise ratio. Since the optimum bias current for any tape depends on that tape's magnetic characteristics, you need a way of varying the bias

PACKING PROCEDURES

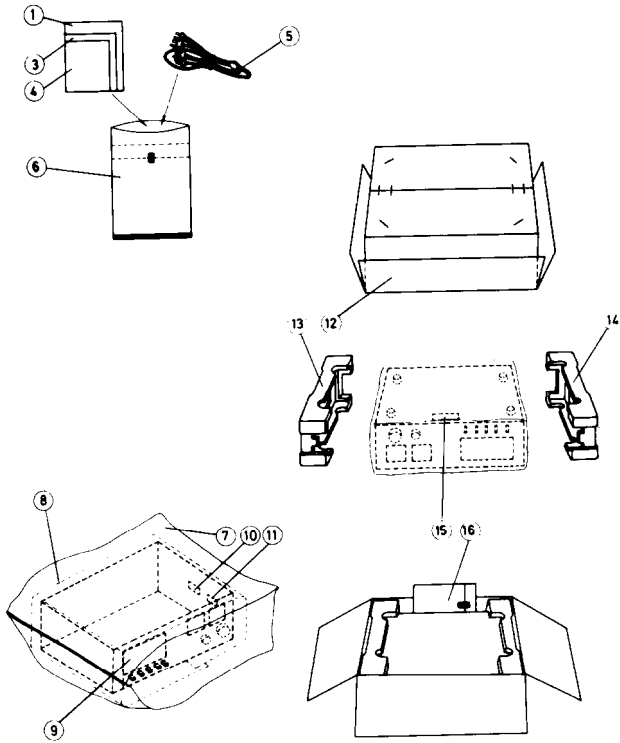

U.S.A. model

REF. NO.	PARTS NO.	DESCRIPTION
1	29340322	Instruction manual
3	29358002	Service station list
4	29365006	Warranty card
5	253074	Pin-pin connection cord
6	29100005	330 x 220 mm, Poly bag
7	29100037	650 x 500 mm, Poly bag
8	29095064	400 x 900 mm, Protection sheet
9	29095079	Protection sheet
10	282969	Caution label (A)
11	29380040	Cabinet composite label
12	29050249	Carton box
13	29090397	Pad (R)
14	29090396	Pad (L)
15	293041	Caution label
16	16419119	Accessory bag complete

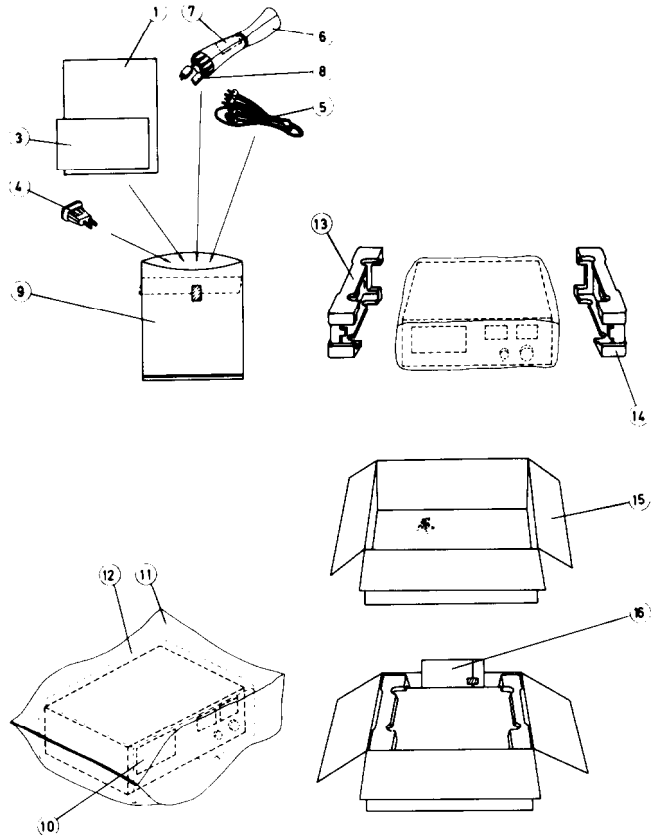

Universal model

REF. NO.	PARTS NO.	DESCRIPTION
1	29340336	Instruction manual
3	29365005	Warranty card (G)
4	25055018	Conversion plug
5	253074	Pin-pin connection cord
6	290076	AC cord wrapper
7	29380038	Voltage tag
8	253083	Power supply cord (U)
	293089	Power supply cord (G)
9	29100006	330 x 250 mm, Poly bag
10	29095079	Protection sheet
11	29100037	650 x 500 mm, Poly bag
12	29095064	400 x 900 mm, Protection sheet
13	29090396	Pad (L)
14	29090397	Pad (R)
15	29050249	Carton box
16		Accessory bag complete (U)
		Accessory bag complete (G)

Note: U: Universal model
G: Germany model

ONKYO CORPORATION

International Division: No. 24 Mori Bldg., 23-5, 3-chome, Nishi-Shinbashi, Minato-ku, Tokyo, Japan
Telex: 2423551 ONKYO J. Phone: 03-432-6981

ONKYO U.S.A. CORPORATION

Eastern Office
42-07 20th Avenue, Long Island City, New York 11105, U.S.A. Phone: (212) 728-4639
Midwest Office
935 Sivert Drive, Wooddale, Illinois 60191, U.S.A. Phone: (312) 595-2970

ONKYO DEUTSCHLAND GMBH, ELECTRONICS

8034 München-Germering, Industriestrasse 18, West Germany. Telex: 521726 Telefon: (089)-84-5041