

ONKYO® SERVICE MANUAL

STEREO CASSETTE TAPE DECK MODEL TA2025

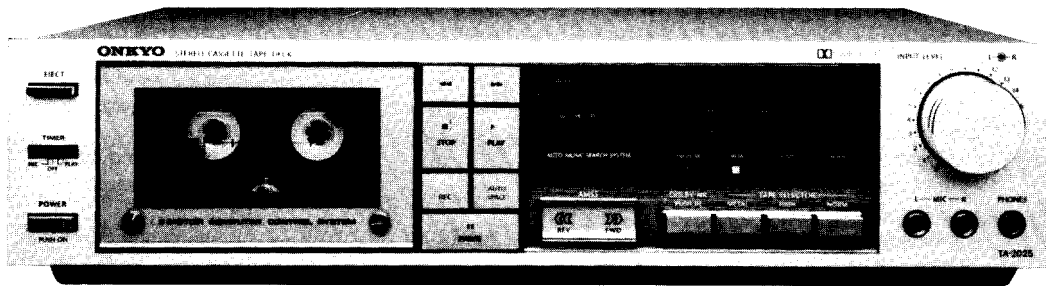

TABLE OF CONTENTS

Item	Page
Specifications	●
Special mode of operation	●
Component location	●
parts list	●
Exploded view	●
Adjustment procedures	●
Block diagram	●
Tape mechanism exploded view	●
Printed circuit board view from component location	●
Printed circuit board-parts list	●
Block diagram of IC	●
Packing procedures	●



SPECIFICATIONS

D model

Track Format:	4-track, 2-channel stereo	
Recording System:	AC bias	
Erasing System:	AC erase	
Tape Speed:	4.8 cm/sec. (1-7/8 i.p.s.)	
Wow & Flutter:	0.045% (WRMS)	
Frequency Response:	20 – 15,000 Hz (30 – 14,000 Hz \pm 3 dB) (normal position tape) 20 – 16,000 Hz (30 – 15,000 Hz \pm 3 dB) (high position tape) 20 – 17,000 Hz (30 – 16,000 Hz \pm 3 dB) (metal position tape)	
Signal-to-Noise Ratio:	60 dB (Metal tape, Dolby Out) A noise reduction of 10 dB above 5 kHz and 5 dB at 1 kHz is possible with the Dolby NR in.	
Input Jacks:	Microphone Jacks: 2	
	Minimum input level:	0.3 mV/600 Ω
	Input impedance:	5 k Ω
	Line In Jacks: 2	
	Minimum input level:	50 mV
	Input impedance:	50 k Ω
Outputs:	Line Out Jacks: 2	
	Standard output level:	500 mV (0 dB)
	Optimum load impedance:	Over 50 k Ω
	Headphone Jack: 1	
		8 Ω – 200 Ω
Motors:	DC servo: 1	
	DC: 2	
Heads:	Rec/pb head: Hard Permalloy	
	Erase head: Ferrite	
Semiconductors:	TR: 41 Diodes; 28	
	IC: 10 LED: 8	
Power Consumption:	18 watts	
Dimensions:	418(W) x 100(H) x 270(D) mm (16-1/2" x 3-15/16" x 10-5/8")	
Weight:	4.5 kg. (9.9 lbs.)	

* Specifications and external appearance are subject to change without prior notice due to product improvements.

Mechanism specifications

- 1) Tape speed: 4.8 cm/sec. (3,000 Hz ~ 3,060 Hz)
Use a standard test tape
VTT-658 (3 kHz) or equipment.
- 2) Wow and Flutter: Less than 0.08% (WRMS)
- 3) Take-up torque: 35 – 55 gr-cm
- 4) F.F. torque: 70 – 140 gr-cm
- 5) Rewind torque: 70 – 140 gr-cm
- 6) Rewind time: Less than 90 sec.
(Use a C-60 cassette tape)

G/W Model

Track Format:	4-track, 2-channel stereo	
Recording System:	AC bias	
Erasing System:	AC erase	
Tape Speed:	4.8 cm/sec. (1-7/8 i.p.s.)	
Wow & Flutter:	0.045% (WRMS)	
Frequency Response:	20 – 15,000 Hz (30 – 14,000 Hz \pm 3 dB) (normal position tape) 20 – 16,000 Hz (30 – 15,000 Hz \pm 3 dB) (high position tape) 20 – 17,000 Hz (30 – 16,000 Hz \pm 3 dB) (metal position tape)	
Signal-to-Noise Ratio:	60 dB (Metal tape, Dolby Out) A noise reduction of 10 dB above 5 kHz and 5 dB at 1 kHz is possible with the Dolby NR in.	
Input Jacks:	Microphone Jacks: 2	
	Minimum input level:	0.3 mV/600 Ω
	Input impedance:	5 k Ω
	Line In Jacks: 2	
	Minimum input level:	50 mV
	Input impedance:	50 k Ω
Outputs:	DIN In Jack: 1	
	Minimum input level:	0.1 mV/1 k Ω
	Input impedance:	2.7 k Ω
	Line Out Jacks: 2	
	Standard output level:	500 mV (0 dB)
	Optimum load impedance:	over 50 k Ω
	DIN Out Jack: 1	
	Standard output level:	500 mV (0 dB)
	Optimum load impedance:	over 50 k Ω
	Headphone Jack: 1	
		8 Ω – 200 Ω over 50 k Ω
Motors:	DC servo: 1	
	DC: 2	
Heads:	Rec/pb head: Hard Permalloy	
	Erase head: Ferrite	
Semiconductors:	TR: 43 Diodes; 3	
	IC: 10 LED: 8	
Power Supply:	G model: 220 V, 50 Hz	
	W model: 120/220 V, 50/60 Hz	
	Q model: 240 V, 50 Hz	
Power Consumption:	18 watts	
Dimensions:	418(W) x 100(H) x 270(D) mm (16-1/2" x 3-15/16" x 10-5/8")	
Weight:	4.5 kg. (9.9 lbs.)	

SPECIAL MODE OF OPERATION

1. Using the AMSS Function

The AMSS (Automatic Music Search System) automatically locates the beginning of each song on a tape and plays the first 15 seconds (approximately) of each one. It is particularly useful to rapidly check the contents of a cassette. When AMSS FWD is pressed during normal tape playback the tape is rapidly wound to the beginning of the next song and, as the play indicator flashes on and off, the first 15 or 16 seconds of that song is played. Then the tape is rapidly wound to the beginning of the next song and, again, the first 15 or 16 seconds is played. This process is repeated until the PLAY button is depressed or the end of the tape is reached. When AMSS REV is pressed, the same process is performed in the reverse direction. If you want to hear the entire song, press the PLAY button to cancel the AMSS function and return to normal playback. The AMSS circuit operates by detection the blank sections between songs. If the space between songs is too short, the AMSS circuit may go on to the next blank space of sufficient length. In order to assure that the blank sections between songs on your cassettes are sufficiently long, you should use the auto space button to insert these spaces when making recordings.

Note: AMSS REV may not operate properly if there is a very quiet section followed by a very loud section in the 15 to 16 second long portion played at the beginning of one of the songs. If this occurs, press AMSS REV again to continue AMSS REV operation.

2. Voltage Selector (on Rear Panel)

W model is equipped with a voltage selector. If the unit you own has a voltage selector, be sure it is set to the proper voltage before the power is turned on. To change the selector to conform to the power supply in your area, insert the tip of a screwdriver in the groove of the switch and slide it all the way to the left or right.

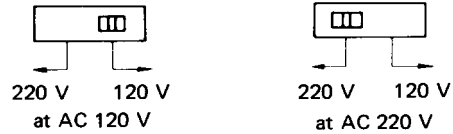

Note: Units not equipped with a voltage selector can only be used in areas where the power supply agrees with the voltage specified on the rear panel.

COMPONENT LOCATION

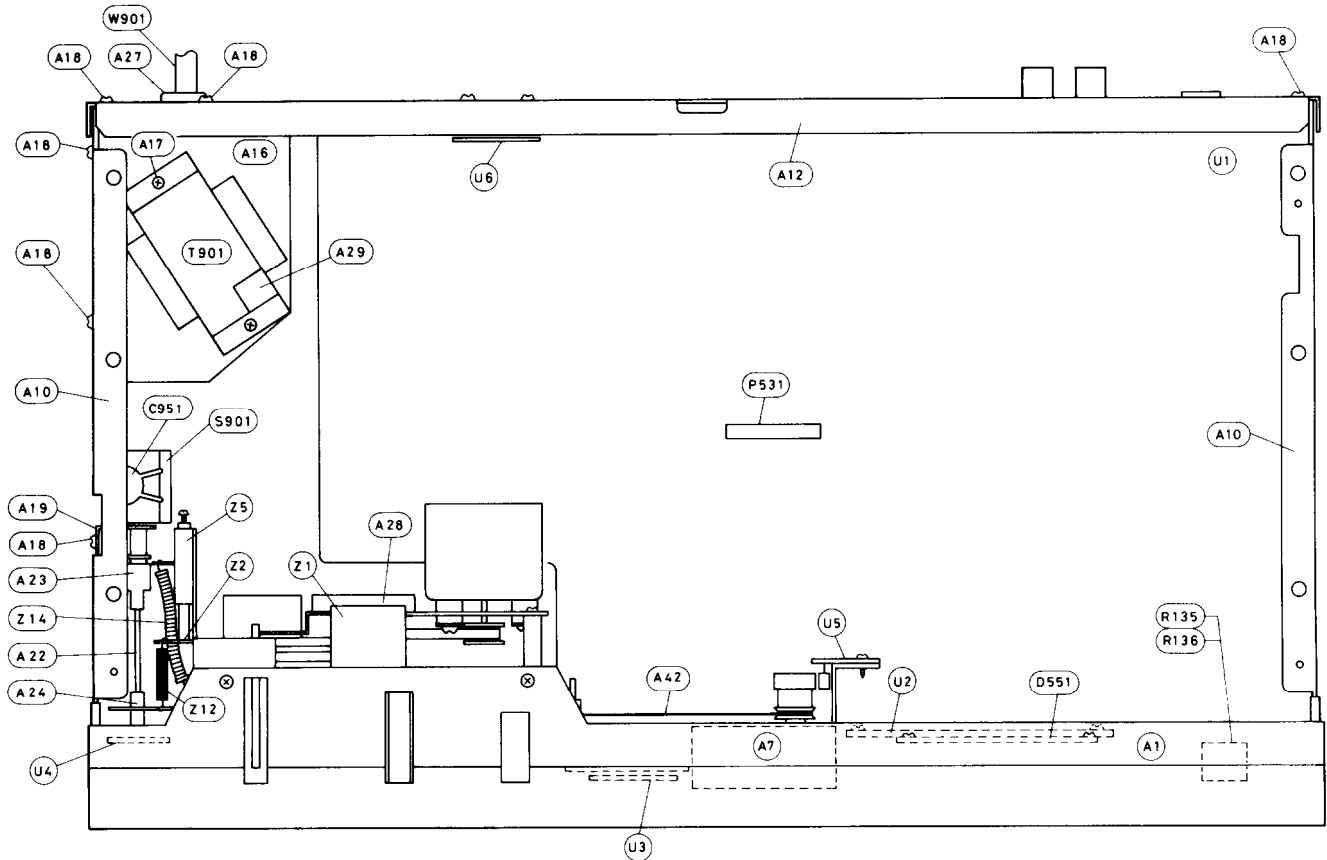

REF. NO.	PARTS NO.	DESCRIPTION	REF. NO.	PARTS NO.	DESCRIPTION
A1	27110154-1	Front bracket	A32	24610643	Tape mirror
A2	27140586	Bracket, pc board	A34	27190135-1	Holder, left side
A3	834130088	3TTS+8B, Tap screw	A35	27190136-1	Holder, right side
A4	27130282	Bracket, pc board	A36	27300445-1	Case, cassette
A5	27270089	Spacer	A37	838126088	2.6TTB+8B, Tap screw
A6	831130068	3TTW+6B, Tap screw	A38	27180102	Spring
A7	24601100	Counter	A39	27300446	Lever
A8	27140587A	Bracket, auto-stop	A40	27180101-1	Spring
A9	28320387	Knob, counter	A41	28140376	Cushion
A10	27115096A	Side bracket	A42	24602128	Belt, counter
A11	833130080	3TTP+8P, Tapping screw	A45	838126088	2.6TTB+8B, Tap screw
A12	27120363	Back panel (D)	A48	82542610	2.6B+10FN(BC), Screw
	27120364	Back panel (G)	A49	863126	N-2.6FN(BC), Nut
	27120365	Back panel (W)	A51	82112604	2.6P+4F, Pan head screw
A13	834130068	3TTS+6B, Tap screw	A53	800137	M3x6x1t, Nut
A14	838126088	2.6TTB+8B, Tap screw	A54	8771301010	W3x10F, Washer
A15	833130080	3TTP+8P, Tap screw	A57	27190123A	Holder
A16	27130247-1A	Bracket, power transformer	A59	29110029	Adhesive tape
A17	833140087	4TTP+8S, Tap screw	A351	28184126A	Top cover
A18	834130068	3TTS+6B, Tap screw	A352	834430068	3TTS+6B(BC), Tap screw
A19	27140478	Bracket, power	A353	834130068	3TTS+6B, Tap screw
A20	834130068	3TTS+6B, Tap screw	A501	1621812	Front panel ass'y
A21	82113006	3P+6FN, Pan head screw	A502	834130088	3TTS+8B, Tap screw
A22	27260069	Shaft, power switch	A503	833130080	3TTP+8P, Tapping screw
A23	28320135	Connector	A505	28140252	Cushion
A24	27273016	Joint	A507	28191104A	Clear plate
A25	28140233	Cushion	A508	27267158	Guide, switch
A26	28140291	Cushion	A509	27267109	Guide, power
A27	270025	SR-3P4, Strainrelief (D)	A512	27300444	Lid
	270280	SR-4K-4, Strainrelief (G/W)	A513	801249	Screw
A28	28175045	Shielded plate	A514	870085	Washer
A29	28140020	Cushion	A518	27180021	Spring
A30	223004-1	Terminal	A522	260701	Adhesive tape
A31	28130132	Dial plate	A523	29110029	Adhesive tape

EXPLODED VIEW

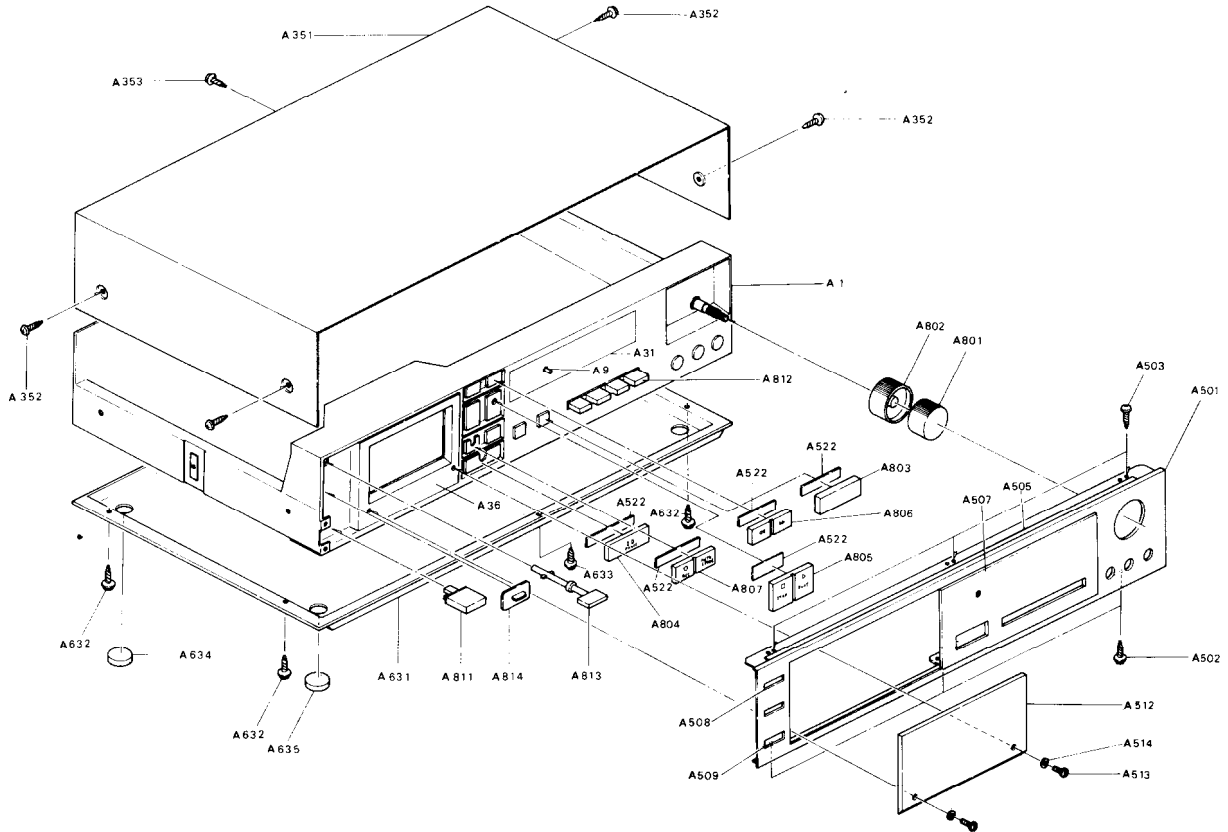

REF. NO.	PARTS NO.	DESCRIPTION	REF. NO.	PARTS NO.	DESCRIPTION
A631	27170116A	Bottom board	U1	16389555	NAAF-1255, Rec/pb amplifier and control pc board ass'y (D)
A632	831130068	3TTW+6B, Tap screw		16224555A	NAAF-1255A, Rec/pb amplifier and control pc board ass'y (G/W)
A633	831130088	3TTW+8B, Tap screw	U2	16389556	NADIS-1256, Dolby and tape selector indicator L.E.D pc board ass'y
A634	27175028	Leg	U3	16389557	NASW-1257, Control switch pc board ass'y
A635	28143014A	Leg	U4	16389558	NASW-1258, Timer switch pc board ass'y
A636	838130068	3TTP+6B, Tap screw	U5	16389559	NAPD-1259, Hall IC pc board ass'y
A801	28320671	Knob, input level, left side	U6	16218513	NARM-1313, Remote control terminal pc board ass'y
A802	28320672	Knob, input level, right side	Z1	244031-1	Tape deck mechanism
A803	28320683	Knob, REV/FWD	Z2	27140588A	Bracket, eject
A804	16389704	Knob, pause	Z3	27300447A	Lever, eject
A805	16389705	Knob, stop/play	Z4	27300448	Locked plate
A806	28320681A	Knob, FF/Rew	Z5	24610508	Damper
A807	16389706	Knob, Rec/Auto space	Z6	833125059	2.5TTP+5C, Tap screw
A811	28320573	Knob, push	Z7	870090	Washer
A812	28320742	Knob, selector	Z8	833126060	2.6TTP+6P, Tapping screw
A813	28320678	Knob, eject	Z9	8930301S	ES-3S, Circlip
A814	28320640	Knob, switch	Z12	27180109	Spring
C951	3500060	0.01 μ F, 125V, Capacitor, CS (D)	Z14	27180114-1	Spring
C951	3500065A	0.01 μ F, AC400V, Capacitor, IS (G)	Z16	834126068	2.6TTP+6B, Tap screw
C951, C952	3500065A	0.01 μ F, AC400V, Capacitor, IS (W)		25065123	NSS-1258P, Voltage selector (W)
	27300080	Cover, Capacitor			
D551	225099	TLM8102, L.E.D, meter	Note:		(D) : Only 120V model
P531	25050071	NSAS-12P038, Socket, meter			(G) : Only 220V model
R135, R136	5104133	N16RK50KA25F, Variable resistor, input level			(W) : Only 120/220V model
S901	25035224	NPS-121-L188P, Power switch (D)			
	25035192	NPS-122-L156P, Power switch (G)			
	25035207	NPS-121-L171P, Power switch (W)			
T901	230581	NPT-762D, Power transformer (D)			
	230583	NPT-762G, Power transformer (G)			
	230582	NPT-762DG, Power transformer (W)			
W901	253099A	AS-UC-3, Power supply cable (D)			
	253083	AS-CEE, Power supply cable (G/W)			

ADJUSTMENT PROCEDURES

PRECAUTIONS

- Before adjustment, clean the following parts with an alcohol moistend swab.
 - * record/playback head
 - * erase head
 - * pinch roller
 - * capstan
 - * rubber belt
- Do not use magnitized screwdriver for adjustments.
- Demagnetize record/playback head with a head demagnetizer.
- The switches and controls should be set as follows unless otherwise specified.

TAPE SEL	NORM
DOLBY NR	OUT
INPUT LEVEL	0
TIMER	OFF

1. Play torque adjustment

Play the torque meter TW-2111 back.

Adjust the R707 so that torque of take-up reel becomes 40 gr-cm.

2. Tape speed adjustment

Connect the frequency counter to the line output terminal. Play the MTT-111 back.

Adjust the semi-fixed resistor on the motor control pc board so that the counter indication becomes 3,000 Hz.

3. Head azimuth adjustment

- Play the test tape VTT-658 back.
- Adjust the head azimuth screw so that the phase relationship between L-and R-channels approximates 0 degrees as indicated on the oscilloscope.
- At this time confirm that play back output level is approximately the maximum value on the AC voltmeter.
- Then confirm that the phase difference of the respective frequency is with in the rated value 90 degrees or less in the range of 40 Hz to 10 kHz is required.
- Secure the screw with the locking paint.

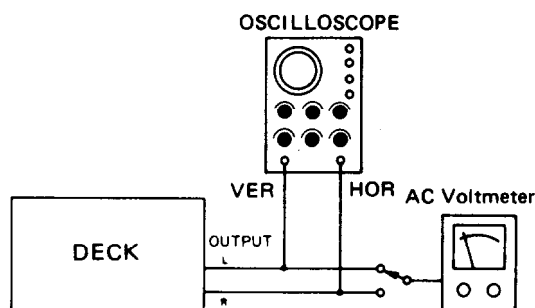

TEST EQUIPMENT/TOOLS REQUIRED:

- Audio oscillator
- Digital frequency counter
- Oscilloscope
- Attenuator
- AC voltmeter
- Non-magnetic screw drive
- Blank tapes (completely erased)

NORMAL	UD-XL/I
HIGH	UD-XL/II
METAL	MX
- Test tapes

VTT-658	:	10 kHz, - 15 dB
MTT-111	:	3 kHz, - 10 dB
MTT-150	:	Dolby level calibration 400 Hz tone 200 nWb/m
TW-2111	:	Torque meter

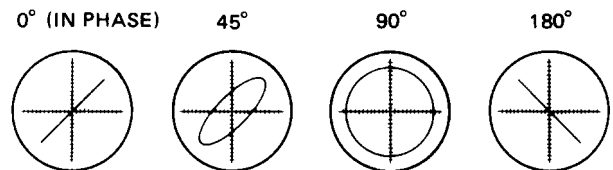

Confirming phase relationship

4. Playback output level adjustment

Connect the AC voltmeter to the TP-R and TR-L terminals. Play the MTT-150 back.

Adjust the R111 and R112 so that the indication of AC voltmeter becomes 580 mV.

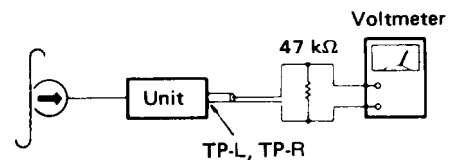

5. Level meter adjustment

Play the MTT-150 back.

Adjust the R533 so that the 0 dB of level meter light on.

6. Bias current adjustment

Insert the normal blank tape into the cassette holder. Apply the 400 Hz signal to the line input terminal. Press the rec and pause button together and set the tape deck to the recording mode. Adjust the input level volume or AF oscillator so that the 0 dB of level meter light on. Reduce the input level by 20 dB with the attenuator. Record the 400 Hz and 10 kHz signals on the tape. Adjust the R205 and R206 so that the 400 Hz and 10 kHz playback signal become the same level.

7. Recording level adjustment

Apply the 700 Hz signal to the line input terminal. Insert the normal blank tape into the cassette holder. Connect the AC voltmeter to the line output terminal. Set the tape deck to the recording mode. Adjust the input volume or AF oscillator output so that the 0 dB of level meter light on. Reduce the input level by 3 dB. Record the 700 Hz signal on the tape and adjust the R181 and R182 so that the level of recording and playback become same.

Connection diagram

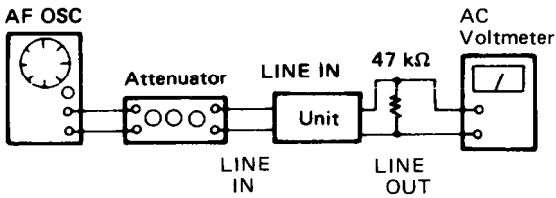

8. Hall IC clearance

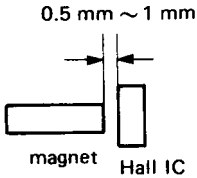

9. Adjustment of the eject mechanism

The speed of the opening and closing action of the cassette compartment can be controlled by the adjustment screw at the rear of the cylinder as shown in the graph. By turning the screw to the left, speed becomes faster, and to the right, and to the right, slower.

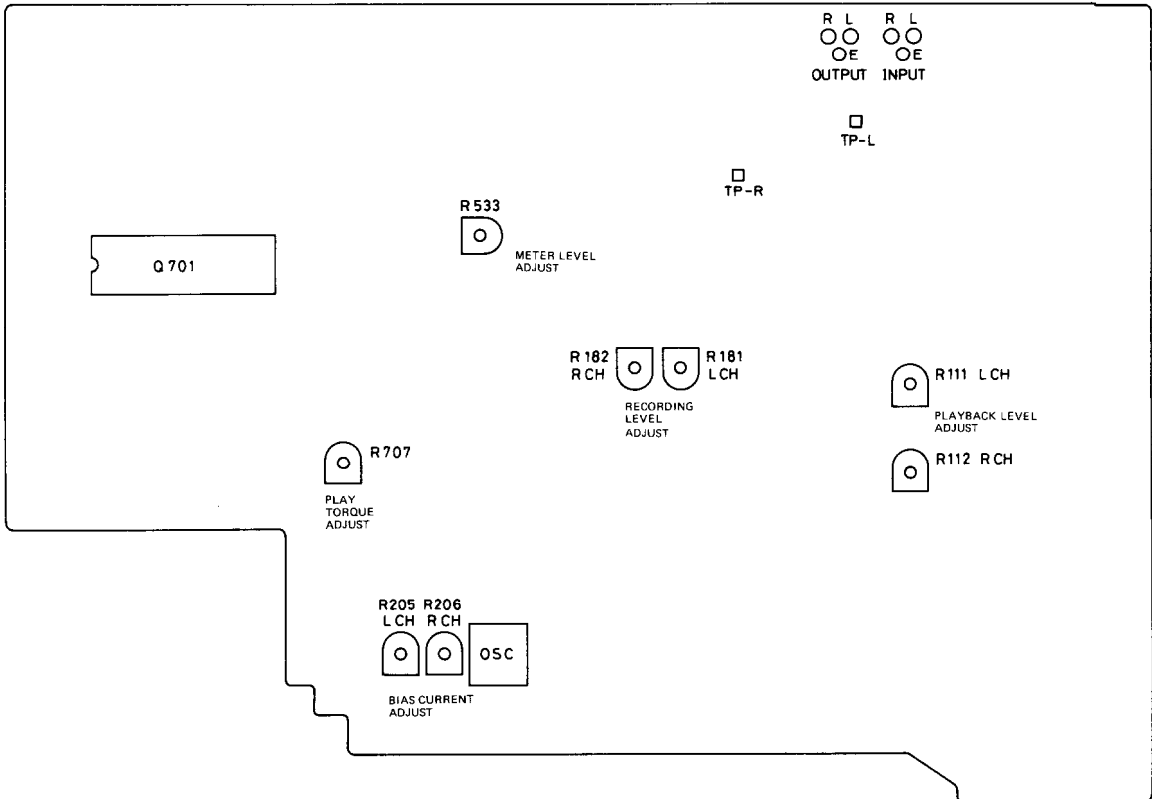
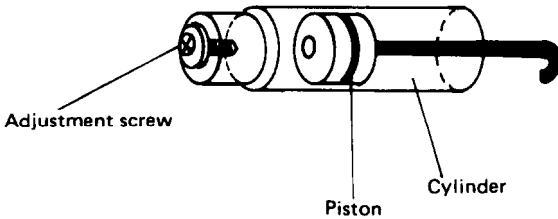

BLOCK DIAGRAM

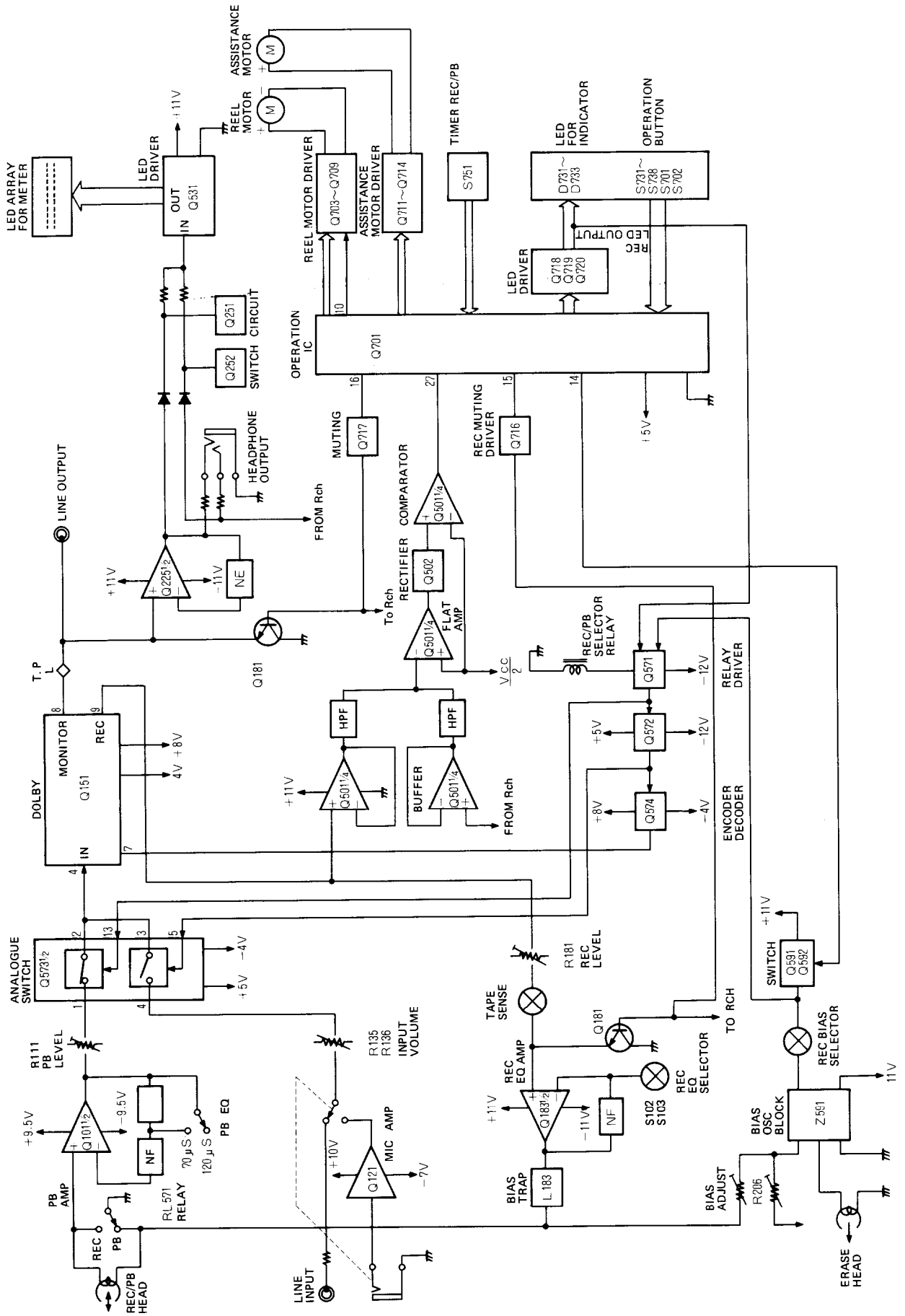

TAPE MECHANISM EXPLODED VIEW

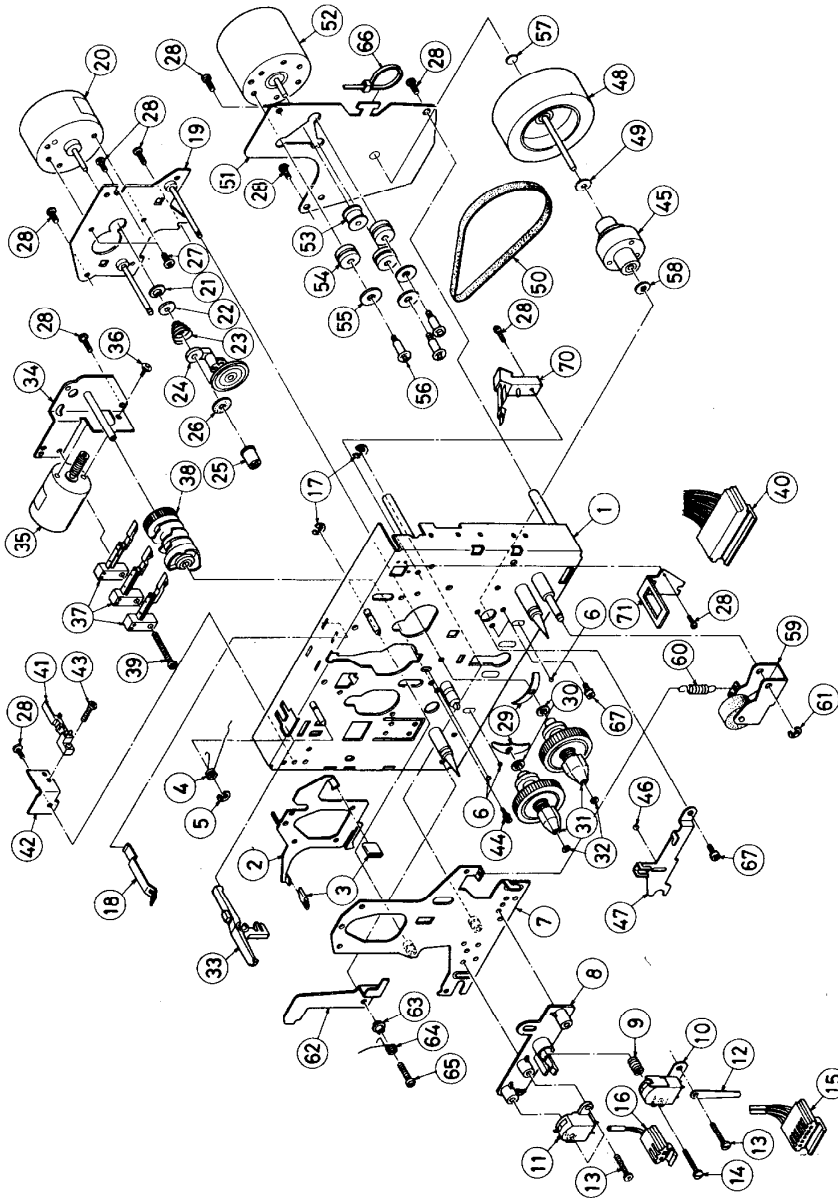

REF. NO.	PARTS NO.	DESCRIPTION
31	24602136	Reel stand
32	24610349	Washer
33	24603205	Recording lever
34	24610668	Chassis
35	24601103	Motor, assistance
36	801259	M2x3, Screw
37	24606119	Leafswitch
38	24602133	Cam gear
39	833125209	M2.5x20, Pan head screw
40	25050127	Connector, 10P (Before change)
41	25050117	Connector, 11P (After change)
42	24603129	Leafswitch
43	24610660	Chassis
44	833125069	M2.5x6, Pan head screw
45	801250	M2x4, Pan head screw
46	24610674	Capstan holder
47	24610279	3/8" steelball
48	24610669	Head holding plate
49	24602135	Flywheel
50	24610515	Washer
51	24602134	Belt
52	24610670	Flywheel holding plate
53	24601085	Capstan motor ass'y (See No. 69)
54	24601107	Motor pulley
55	24610451	Cushion
56	24610452	Flat washer
57	801252	Screw, motor
58	24610671	Thrust stand
59	24610673	Plain washer
60	24610672	Pinch arm ass'y 2, 3, 3, 0
61	24603370	Spring
62	8930201	E2, Circlip
63	24610345	Locked plate
64	24610344	Collar
65	24605184	Spring
66	833125109	M2.5x10, Pan head screw
67	260208	Binder
68	801181	M2.6x6, Pan head screw
69	24601106	Reel motor/idler ass'y (20-26)
70	24601113	Capstan motor ass'y (52, 53)
71	24606104	Leafswitch
71	24610659	Protection plate

REF. NO. PARTS NO. DESCRIPTION

1	24610663	Mechanism chassis
2	24610664	Brake plate
3	24610376	Rubber, brake
4	24605304	Spring
5	8930251	E2.5, Circlip
6	24610351	2a, steelball
7	24610665	Head chassis
8	24610346	Head stand
9	24605185	Spring
10	24600018	Res/playback head
11	24600025	Erase head
12	24610666	Holder, lead wire
13	82512012	M2x13, Binding screw
14	801198	M2x1.4, Flange screw
15	25050115	Connector, rec/job head
16	25050113	Connector, erase head
17	8930302	E3, Circlip
18	24605183	Cassette holding spring
19	24610667	Motor chassis
20		Reel motor (See No. 68)
21	24610373	Stand, spring
22	24610374	Washer
23	24605194	Spring
24	24602076	Idler lever ass'y
25	24601102	Motor pulley
26	24610375	Felt
27	82512603	M2.6x3, Binding screw
28	833125059	Pan head screw
29	24605303	Back tension spring
30	24610992	Washer

PRINTED CIRCUIT BOARD-PARTS LIST

REC. AND PLAYBACK AMPLIFIER PC BOARD (NAAF-1125) – PARTS LIST

CIRCUIT NO.	PARTS NO.	DESCRIPTION	CIRCUIT NO.	PARTS NO.	DESCRIPTION
			D903, D904	2239631 or 224111	RD12EB1 or GZA12L
			D905	2239472, 2239473 or 224096	RD5.6EB2, RD5.6EB3 or GZA5.6U
	ICs			Capacitors	
Q101	222655	NJM4562DD	C107, C108	352721019	100μF, 6.3V, Elect.
Q151, Q152	222635	TA7629P, Dolby	C121–C124	352780109	1μF, 50V, Elect.
Q183	222465	NJM4558D	C151, C152	352780109	1μF, 50V, Elect.
Q225	222654	NJM4556D	C153, C154	352732219	220μF, 10V, Elect.
Q501	222604	LM324N	C155, C156	352741009	10μF, 16V, Elect.
Q531	222507	TA7612P, Meter drive	C159, C160	352741009	10μF, 16V, Elect.
Q573	222575	TC4066BP, Analogic, switch	C167, C168	352781099	0.1μF, 50V, Elect.
Q701	222637	TMP4315AP-1011, Micro computer	C169, C170	352783399	0.33μF, 50V, Elect.
	Transistors		C171, C172	352741009	10μF, 16V, Elect.
Q121, Q122	2211406	2SC2240(BL)	C181, C182	352741009	10μF, 16V, Elect.
Q181, Q182	2211255	2SC1815(GR)	C183, C184	352784799	0.47μF, 50V, Elect.
Q221, Q222	2211255	2SC1815(GR)	C193, C194	352741009	10μF, 16V, Elect.
Q223, Q224	2210274	2SK30A(Y), [G/W]	C221, C222	352741009	10μF, 16V, Elect.
Q251, Q252	2211255	2SC1815(GR)	C251, C252	352780339	3.3μF, 50V, Elect.
Q502	2211454, 2211453, 2212124 or 2212123	2SA1015(Y), 2SA1015(O), 2SA1048(Y) or 2SA1048(O)	C503	352741009	10μF, 16V, Elect.
Q571	2211706	2SD655(F)	C504, C505	352780109	1μF, 50V, Elect.
Q572, Q574	2211254, 2211253, 2212114 or 2212113	2SC1815(Y), 2SC1815(O), 2SC2458(Y) or 2SC2458(O)	C571	352781099	0.1μF, 50V, Elect.
Q591	2211706	2SD655(F)	C572	352780229	2.2μF, 50V, Elect.
Q592	2211454 or 2212124	2SA1015(Y) or 2SA1048(Y)	C591	352721019	100μF, 6.3V, Elect.
Q702	2211611 or 2211612	2SD471(K) or 2SD471(L)	C592	352780109	1μF, 50V, Elect.
Q703, Q704	2211554	2SA562TM(Y)	C703	352780229	2.2μF, 50V, Elect.
Q705, Q707	2212114, 2212113, 2211254 or 2211253	2SC2458(Y), 2SC2458(O), 2SC1815(Y) or 2SC1815(O)	C704, C705	352780109	1μF, 50V, Elect.
Q709, Q715	2211544 or 2211543	2SC1959(Y) or 2SC1959(O)	C709	352781099	0.1μF, 50V, Elect.
Q710	2201060	2SD549	C710	352780109	1μF, 50V, Elect.
Q711, Q712	2211554	2SA562TM(Y)	C711	352741009	10μF, 16V, Elect.
Q713, Q714	2211706	2SD655(F)	C902	352752229	2,200μF, 25V, Elect.
Q716–Q720	2211454, 2211453, 2212124 or 2212123	2SA1015(Y), 2SA1015(O), 2SA1048(Y) or 2SA1048(O)	C903	352751029	1,000μF, 25V, Elect.
Q721, Q722	2211254, 2211253, 2212114 or 2212113	2SC1815(Y), 2SC1815(O), 2SC2458(Y) or 2SC2458(O)	C908–C911	352741019	100μF, 16V, Elect.
Q901	2201285 or 2201286	2SD882(Q) or 2SD882(P)	C913	3504168	13,000μF, 25V, Elect.
Q902, Q903	2201275 or 2201276	2SB772(Q) or 2SB772(P)	C931, C932	352780109	1μF, 50V, Elect.
Q904	2201074	2SD880(Y)	C933	352741019	100μF, 16V, Elect.
Q905	2212114	2SC2458(Y)	C934	352732219	220μF, 10V, Elect.
Q906	2211563	2SB562(C)	C935	352721019	100μF, 6.3V, Elect.
	Diodes		C936	352731019	100μF, 10V, Elect.
D221, D222	223133 or 223105	DS442X or [G/W] 1S1555	R111, R112	5215046	N08HR50KBC, Semi-fixed
D251, D252	223103 or 223132	1N60 or 1K60	R181, R182	5215045	N08HR10KBC, Semi-fixed
D253–D256	223133 or 223106	DS442X or 1S1554	R205, R206	5215047	N08HR100KBC, Semi-fixed
D501, D571	223133 or 223105	DS442X or 1S1555	R533	5215045	N08HR10KBC, Semi-fixed
D531–D534	2239513 or 224100	RD6.8EB3 or GZA6.8U	R593	441524714KF	470Ω, 1/2W, Metal oxide film
D572	2239551 or 224102	RD8.2EB1 or GZA7.5U	R595	441521024KF	1kΩ, 1/2W, Metal oxide film
D701	223133 or 223105	DS442X or 1S1555	R702	441521004KF	10Ω, 1/2W, Metal oxide film
D703	223103 or 223132	1N60 or 1K60	R707	5215042	N08HR1KBC, Semi-fixed
D705–D711	223133 or 223105	DS442X or 1S1555	R711	441723904KF	39Ω, 2W, Metal oxide film
D712	223103 or 223132	1N60 or 1K60	R717–R726	49121392410	3.9kΩx10, 1/8W, Network
D901	223868	2W02	R727–R736	49121562410	5.6kΩx10, 1/8W, Network
D902	223804 or 223848	SR1K-2 or GP08B	R742–R746	49121223405	22kΩx5, 1/8W, Network
			R901, R903	441520224F	2.2Ω, 1/2W, Metal oxide film
			R904, R906		
			R907	441622704KF	27Ω, 1W, Metal oxide film
				Coils	
			L151, L152	233246	NMC5030
			L181, L182	24606072	NCH-1010
			L183, L184	233186	NCH-3032
			L592	233235	NCH-2050
			Z591	24606117	NOB-018
				Osc. block	
			L701	232100	NMIF-6030
				Transformer	
				Switches	
			S101–S104	25035285	NPS-222-262-L251, Dolby/Tape selector
			S701, S702	25035286	NPS-111-L252, Search
				Plugs	
			P101	25055037	NPLG-6P28
			P102	25055038	NPLG-2P29
			P531	25065133	NPLG-12P18
			P701	25055046	NPLG-10P34 (Before change)
				25055052	NPLG-11P40 (After change)

CIRCUIT NO.	PARTS NO.	DESCRIPTION
Jacks		
P121, P122	25045111	HLJ-4305-01-010, Microphone
P502	25045110	HLJ-4305-01-020, Stereo headphone
Terminal		
P501	25045084	NPJ4PDKBL42, Input/output
P503	25050064	NSCT-5P18, DIN [G/W]
Relay		
RL571	25065174	NRL-2P1ADC12-09

DOLBY AND TAPE SELECTOR INDICATOR L.E.D PC BOARD (NADIS-1256)

CIRCUIT NO.	PARTS NO.	DESCRIPTION
D601	225084	SLP-153B, Dolby, L.E.D
D602-D604	225085	SLP-253B, Tape selector, L.E.D

CONTROL SWITCH PC BOARD (NASW-1257)

CIRCUIT NO.	PARTS NO.	DESCRIPTION
D731, D733	225059	SEL1110S, Rec/Pause indicator L.E.D
D732	225060	SEL1301E, Play indicator L.E.D
S731-S738	25035275	NPS-111-S239, Push switch
	27190086	Holder

TIMER SWITCH PC BOARD (NASW-1258)

CIRCUIT NO.	PARTS NO.	DESCRIPTION
S751	25065170	NSS-2377, Timer switch

HALL IC PC BOARD (NAPD-1259)

CIRCUIT NO.	PARTS NO.	DESCRIPTION
Q751	222558 or 222599	DN6838 or TL170C, IC

REMOTE CONTROL TERMINAL PC BOARD (NARM-1313)

CIRCUIT NO.	PARTS NO.	DESCRIPTION
	25050070	NSCT-7P20, DIN terminal

Note: G : Only 220V model
W : Only 120/220V model

BLOCK DIAGRAM OF IC

TMP4315AP-1011

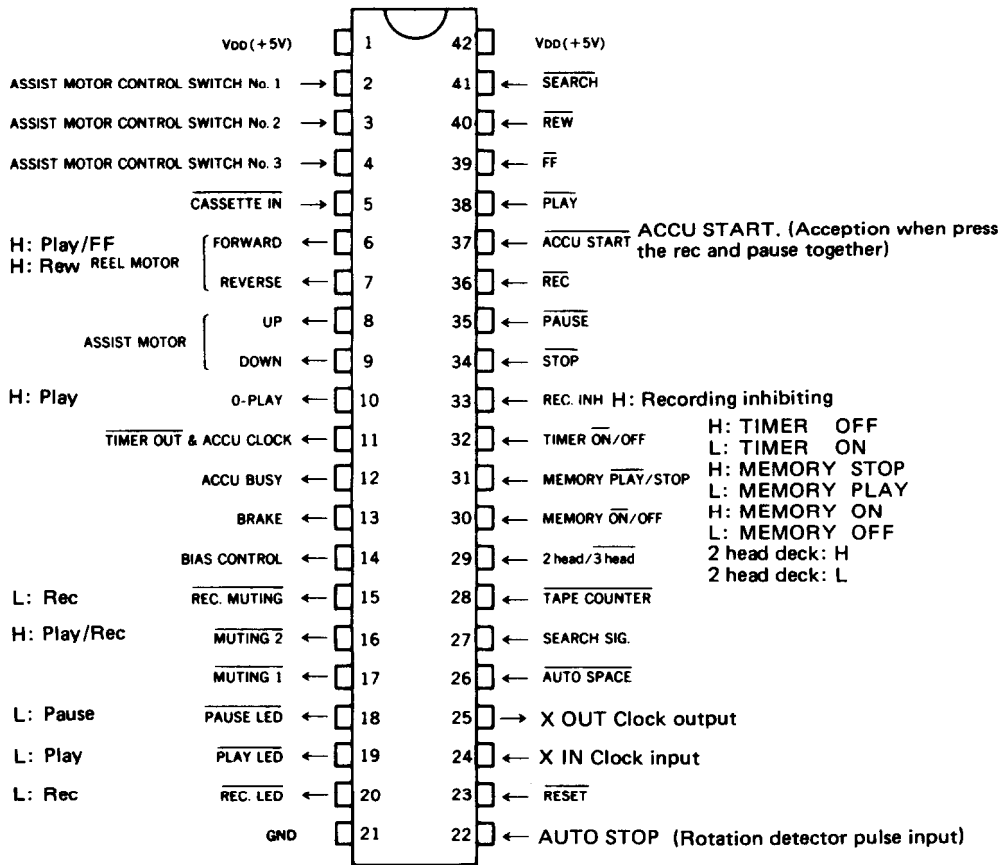

TC4066BP (Analogue switch)

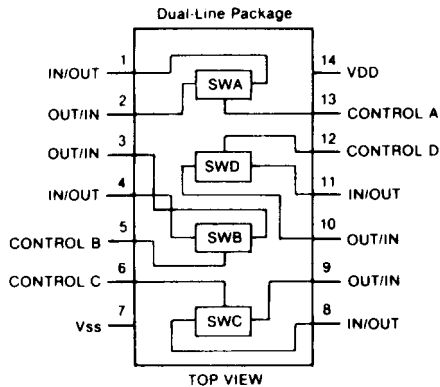

NJM4556/4558 (Operational amplifier)

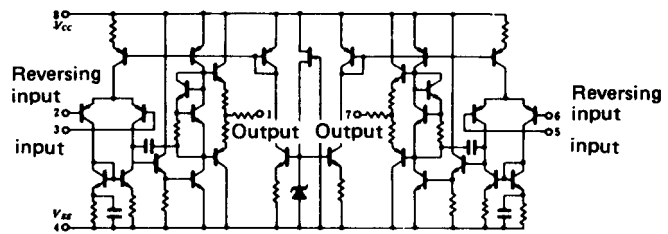

TA7629P (Dolby B type noise reduction)

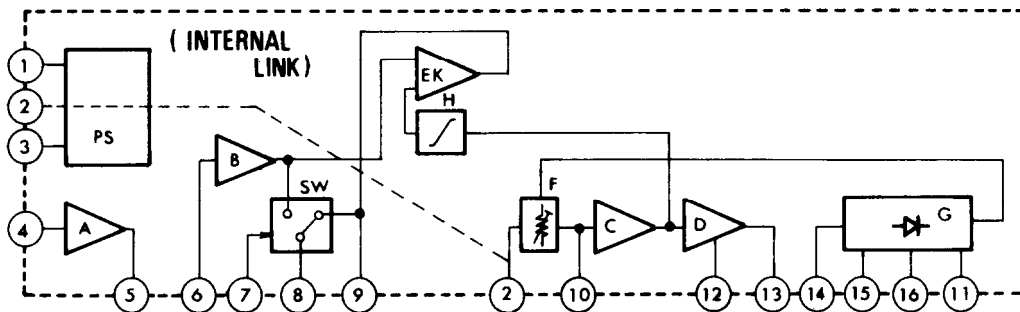

PACKING PROCEDURES

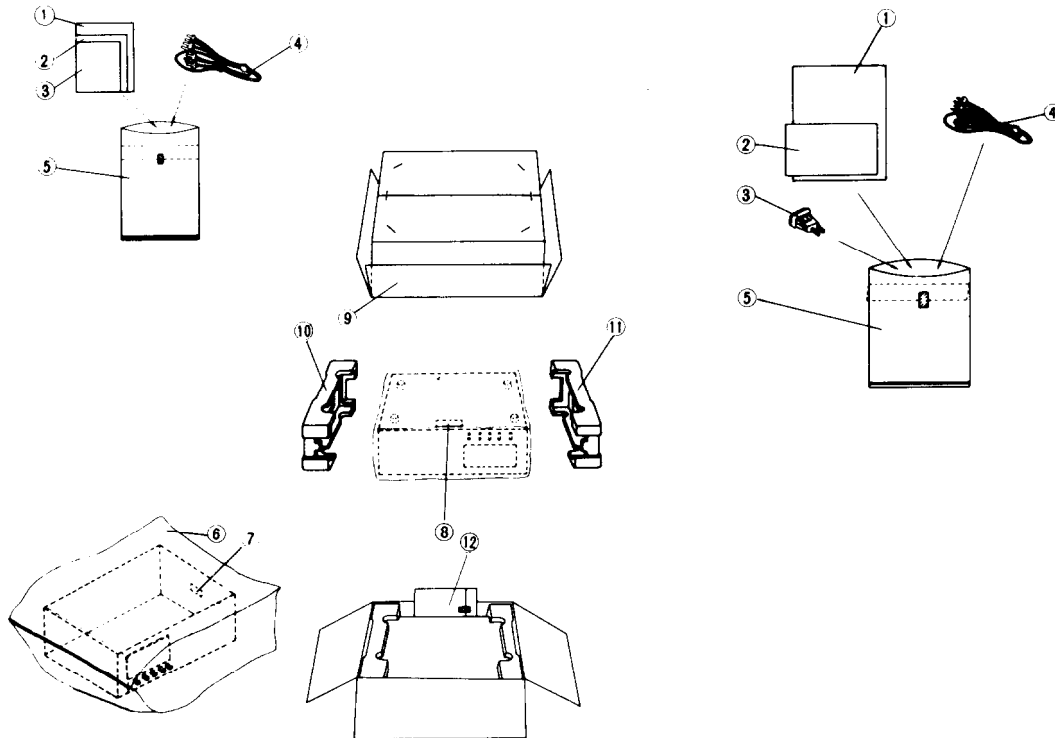

120V model

REF. NO.	PARTS NO.	DESCRIPTION
1	29340587	Instruction manual
2	29358002	Service station list (D)
3	29365006-1	Warranty card (D)
4	253074	Pin-pin connection cord
5	29100005	330 x 220 mm, Poly bag
6	29100037	650 x 500 mm, Poly bag
7	29360363	Caution label (D)
8	29360378	Caution label (D)
9	29050537	Carton box
10	29090647	Pad (R)
11	29090646	Pad (L)
12		Accessory bag complete

(D) : Only U.S.A. model

G/W model

REF. NO.	PARTS NO.	DESCRIPTION
1	29340588	Instruction manual
2	29365005-3	Warranty card (G)
3	25055040	Conversion plug (W)
4	253074	Pin-pin connection cord
5	29100005	330 x 220 mm, Poly bag
6	29100037	650 x 500 mm Poly bag
9	29050537	Carton box
10	29090647	Pad (R)
11	29090646	Pad (L)
12		Accessory bag complete

(G) : Only West Germany

(W) : Only 120/220V model

ONKYO CORPORATION

International Division: No. 24 Mori Bldg., 23-5, 3-chome, Nishi-Shinbashi, Minato-ku, Tokyo, Japan
Telex: 2423551 ONKYO J. Phone: 03-432-6981

ONKYO U.S.A. CORPORATION

Eastern Office: 200 Williams Drive, Ramsey, N.J. 07446 Tel. 201-825-7950
Midwest Office: 107 North Lively Blvd., Elk Grove, IL 60007 Tel. 312-364-5010
Western Office: 8607 Canoga Ave., Canoga Park, CA, 91304 Tel. 213-314-8114

ONKYO DEUTSCHLAND GMBH, ELECTRONICS

8034 München-Germering, Industriestrasse 18, West Germany. Telex: 521726 Telefon: (089)-84-3071

SCHEMATIC DIAGRAM

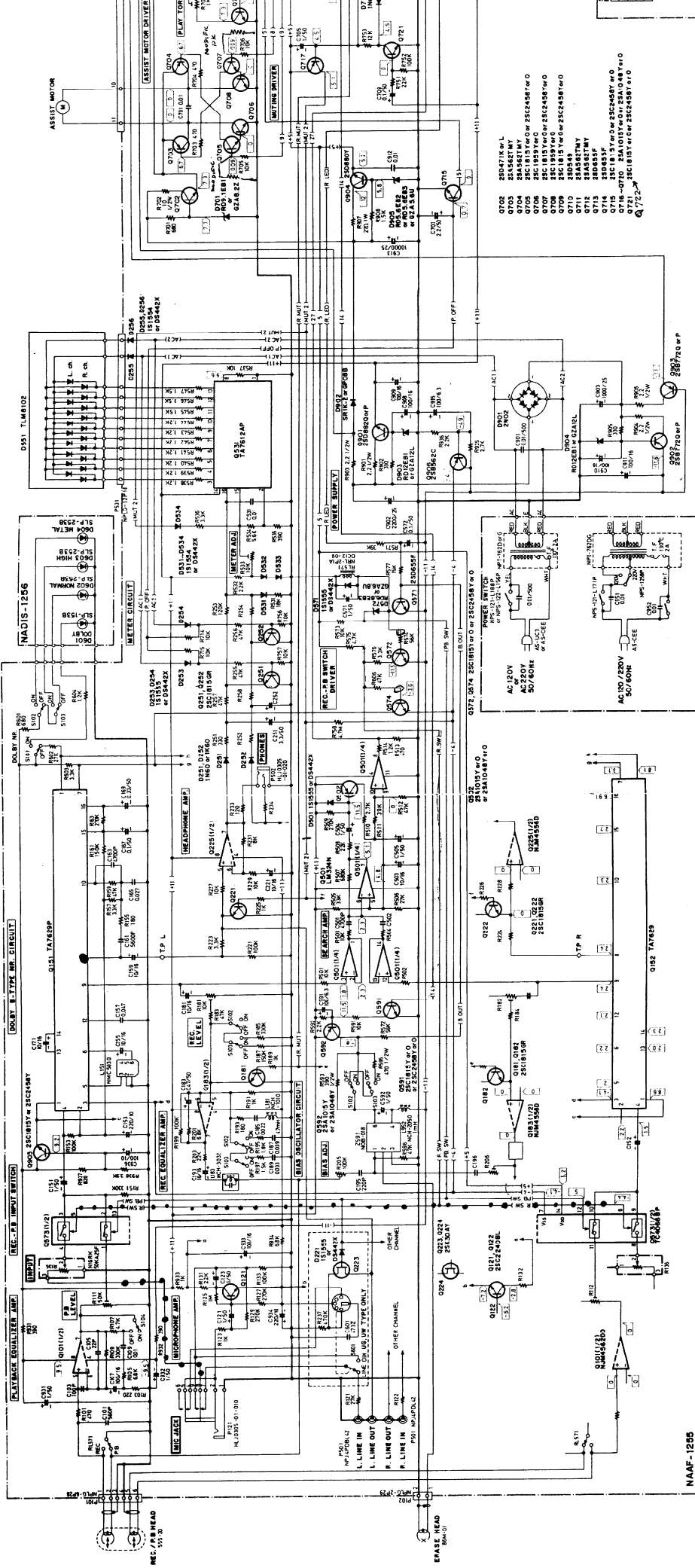

NAAF-1255

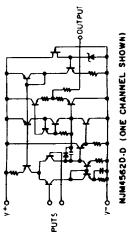
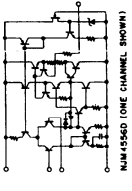
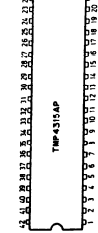
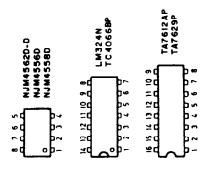

- Q02 2N6471KPL
- Q03 2N5464
- Q04 2N5465
- Q05 2N5466
- Q06 2N5467
- Q07 2N5468
- Q08 2N5469
- Q09 2N5470
- Q10 2N5471
- Q11 2N5472
- Q12 2N5473
- Q13 2N5474
- Q14 2N5475
- Q15 2N5476
- Q16 2N5477
- Q17 2N5478
- Q18 2N5479
- Q19 2N5480
- Q20 2N5481
- Q21 2N5482
- Q22 2N5483
- Q23 2N5484
- Q24 2N5485

- D01 1N4001
- D02 1N4002
- D03 1N4003
- D04 1N4004
- D05 1N4005
- D06 1N4006
- D07 1N4007
- D08 1N4008
- D09 1N4009
- D10 1N4010
- D11 1N4011
- D12 1N4012
- D13 1N4013
- D14 1N4014
- D15 1N4015
- D16 1N4016
- D17 1N4017
- D18 1N4018
- D19 1N4019
- D20 1N4020
- D21 1N4021
- D22 1N4022
- D23 1N4023
- D24 1N4024

- R01 100Ω
- R02 1KΩ
- R03 10KΩ
- R04 100KΩ
- R05 1MΩ
- R06 10MΩ
- R07 100MΩ
- R08 1GΩ
- R09 10GΩ
- R10 100GΩ
- R11 1TΩ
- R12 10TΩ
- R13 100TΩ
- R14 1PTΩ
- R15 10PTΩ
- R16 100PTΩ
- R17 1000PTΩ
- R18 10000PTΩ
- R19 100000PTΩ
- R20 1000000PTΩ
- R21 10000000PTΩ
- R22 100000000PTΩ
- R23 1000000000PTΩ
- R24 10000000000PTΩ

- C01 10pF
- C02 100pF
- C03 1nF
- C04 10nF
- C05 100nF
- C06 1μF
- C07 10μF
- C08 100μF
- C09 1mF
- C10 10mF
- C11 100mF
- C12 1F
- C13 10F
- C14 100F
- C15 1000F
- C16 10000F
- C17 100000F
- C18 1000000F
- C19 10000000F
- C20 100000000F
- C21 1000000000F
- C22 10000000000F
- C23 100000000000F
- C24 1000000000000F

- S01 AC 120V SWITCH
- S02 MICROWAVE SWITCH
- S03 REC-SEARCH SWITCH
- S04 REC-TAP SWITCH

- T01 POWER TRANSFORMER
- T02 MICROWAVE TRANSFORMER

- IC1 N1M4550
- IC2 N1M4552
- IC3 N1M4554

- R01 100Ω
- R02 1KΩ
- R03 10KΩ
- R04 100KΩ
- R05 1MΩ
- R06 10MΩ
- R07 100MΩ
- R08 1GΩ
- R09 10GΩ
- R10 100GΩ
- R11 1TΩ
- R12 10TΩ
- R13 100TΩ
- R14 1PTΩ
- R15 10PTΩ
- R16 100PTΩ
- R17 1000PTΩ
- R18 10000PTΩ
- R19 100000PTΩ
- R20 1000000PTΩ
- R21 10000000PTΩ
- R22 100000000PTΩ
- R23 1000000000PTΩ
- R24 10000000000PTΩ

- C01 10pF
- C02 100pF
- C03 1nF
- C04 10nF
- C05 100nF
- C06 1μF
- C07 10μF
- C08 100μF
- C09 1mF
- C10 10mF
- C11 100mF
- C12 1F
- C13 10F
- C14 100F
- C15 1000F
- C16 10000F
- C17 100000F
- C18 1000000F
- C19 10000000F
- C20 100000000F
- C21 1000000000F
- C22 10000000000F
- C23 100000000000F
- C24 1000000000000F

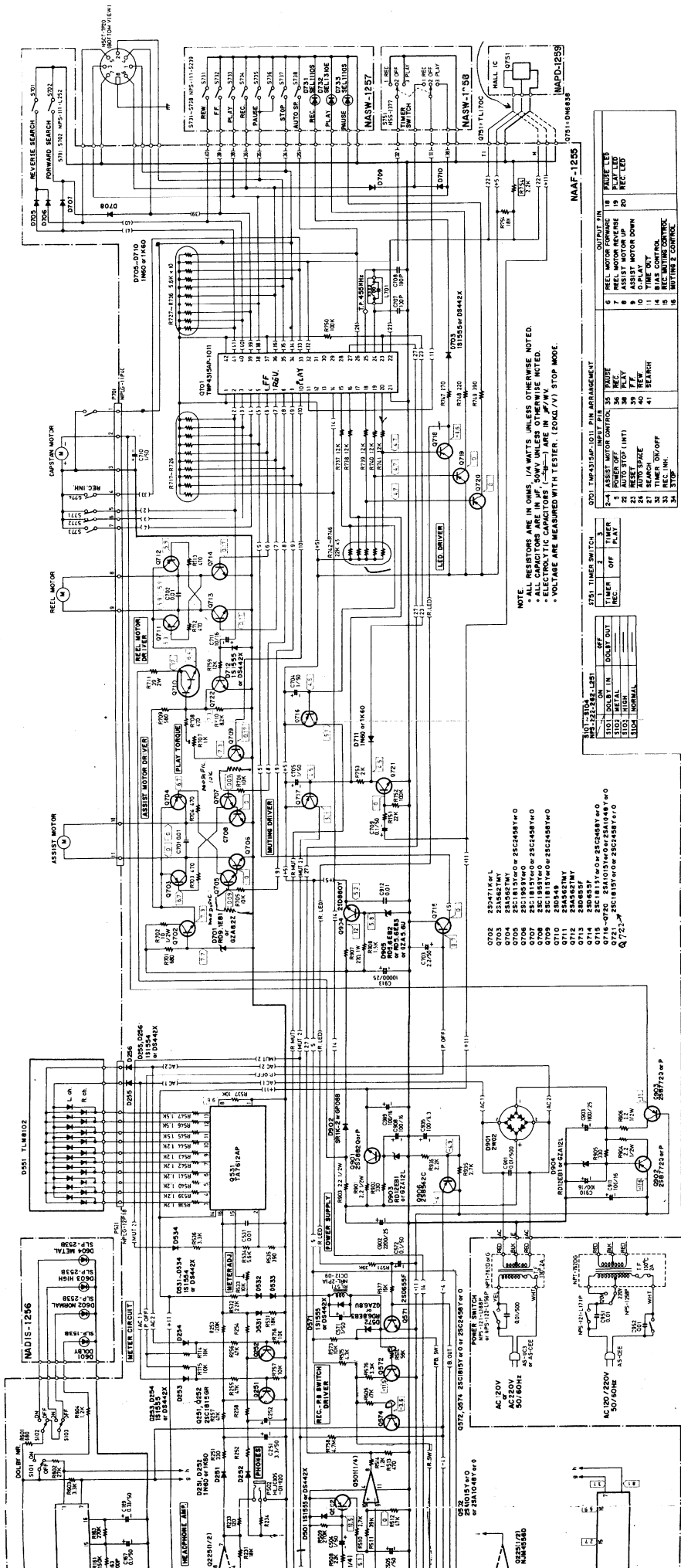

NOTE
 * ALL RESISTORS ARE IN OHMS, 1/4 WATT UNLESS OTHERWISE NOTED.
 * ALL CAPACITORS ARE IN μF, 50V UNLESS OTHERWISE NOTED.
 * VOLTAGE ARE MEASURED WITH TESTER. (200Ω/V) STOP MODE.

0751 TIME SWITCH

1	OFF
2	OFF
3	OFF
4	OFF
5	OFF
6	OFF
7	OFF
8	OFF
9	OFF
10	OFF
11	OFF
12	OFF
13	OFF
14	OFF
15	OFF
16	OFF
17	OFF
18	OFF
19	OFF
20	OFF
21	OFF
22	OFF
23	OFF
24	OFF
25	OFF
26	OFF
27	OFF
28	OFF
29	OFF
30	OFF
31	OFF
32	OFF
33	OFF
34	OFF
35	OFF
36	OFF
37	OFF
38	OFF
39	OFF
40	OFF
41	OFF
42	OFF
43	OFF
44	OFF
45	OFF
46	OFF
47	OFF
48	OFF
49	OFF
50	OFF
51	OFF
52	OFF
53	OFF
54	OFF
55	OFF
56	OFF
57	OFF
58	OFF
59	OFF
60	OFF
61	OFF
62	OFF
63	OFF
64	OFF
65	OFF
66	OFF
67	OFF
68	OFF
69	OFF
70	OFF
71	OFF
72	OFF
73	OFF
74	OFF
75	OFF
76	OFF
77	OFF
78	OFF
79	OFF
80	OFF
81	OFF
82	OFF
83	OFF
84	OFF
85	OFF
86	OFF
87	OFF
88	OFF
89	OFF
90	OFF
91	OFF
92	OFF
93	OFF
94	OFF
95	OFF
96	OFF
97	OFF
98	OFF
99	OFF
100	OFF

0751 MOTOR CONTROL SWITCH

1	OFF
2	OFF
3	OFF
4	OFF
5	OFF
6	OFF
7	OFF
8	OFF
9	OFF
10	OFF
11	OFF
12	OFF
13	OFF
14	OFF
15	OFF
16	OFF
17	OFF
18	OFF
19	OFF
20	OFF
21	OFF
22	OFF
23	OFF
24	OFF
25	OFF
26	OFF
27	OFF
28	OFF
29	OFF
30	OFF
31	OFF
32	OFF
33	OFF
34	OFF
35	OFF
36	OFF
37	OFF
38	OFF
39	OFF
40	OFF
41	OFF
42	OFF
43	OFF
44	OFF
45	OFF
46	OFF
47	OFF
48	OFF
49	OFF
50	OFF
51	OFF
52	OFF
53	OFF
54	OFF
55	OFF
56	OFF
57	OFF
58	OFF
59	OFF
60	OFF
61	OFF
62	OFF
63	OFF
64	OFF
65	OFF
66	OFF
67	OFF
68	OFF
69	OFF
70	OFF
71	OFF
72	OFF
73	OFF
74	OFF
75	OFF
76	OFF
77	OFF
78	OFF
79	OFF
80	OFF
81	OFF
82	OFF
83	OFF
84	OFF
85	OFF
86	OFF
87	OFF
88	OFF
89	OFF
90	OFF
91	OFF
92	OFF
93	OFF
94	OFF
95	OFF
96	OFF
97	OFF
98	OFF
99	OFF
100	OFF

