

ONKYO SERVICE MANUAL

STEREO CASSETTE TAPE DECK MODEL TA-2050

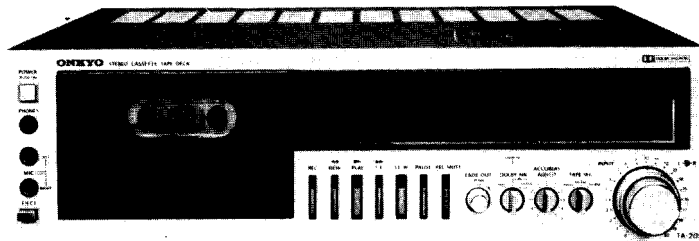

TABLE OF CONTENTS

Item	Page
Specifications	2
Electrical adjustment procedures	2
Exploded view	4
Features	4
Service procedures	5
Precautions	6
Mechanism operation	6
Mechanism adjustments	6
Mechanism exploded view	7
Printed circuit board view	9
Schematic diagram	11
Printed circuit board-parts list	14
Block diagram	15
Circuit description	15
Component location	17
Packing procedures	18

ONKYO
AUDIO COMPONENTS

SPECIFICATIONS

Track System :	4-track, 2-channel stereo	Outputs :	Line Out : 2
Recording System :	AC bias		Output level :
Erasing System :	AC erase		350 mV (at 0 dB)
Tape Speed :	4.8 cm/sec.		Optimum load impedance :
Wow and Flutter :	0.045% (WRMS)		over 50 k Ω
Frequency Response :	20 – 17,000 Hz		Headphone Jack : 1
	(30 – 16,000 Hz \pm 3 dB)		8 Ω / 200 Ω
	(normal position tape)	Motor :	PLL DD motor (capstan)
	20 – 18,000 Hz		+ DC motor
	(30 – 17,000 Hz \pm 3dB)	Heads :	Special hard permalloy heads
	(high position tape)	Components :	TR : 53 Diodes : 29 IC : 6
	20 – 19,000 Hz		LED : 4
	(30 – 18,000 Hz \pm 3 dB)	Power Supply :	AC 120 V/60 Hz,
	(metal position tape)		220 V/50 Hz, 120/120 V
Signal -to-Noise Ratio :	Dolby NR out, 60 dB		50 /60 Hz, 240V/50 Hz
	(metal position tape)	Power Consumption :	35 W
	A noise reduction of 10 dB	Dimensions :	418(W) x 120(H) x 270(D)mm
	above 5 kHz and 5 dB at		16-1/2" x 4-3/4" x 10-5/8"
	1 kHz is possible with the	Weight :	6.4 kg (14.1 lbs.)
	Dolby NR in	Accessories :	Pin-type connecting cords : 2
Input Jacks:	Microphone Jacks : 2		
	Minimum input level :		
	0.3 mV/600 Ω		
	Input impedance : 5 k Ω		
	Optimum mic impedance :		
	600 Ω – 50 k Ω		
	Line In : 2		
	Minimum input level :		
	50 mV		
	Input impedance : 50 k Ω		

*Specifications and external appearance are subject to change without notice because of product improvements.

ELECTRICAL ADJUSTMENT PROCEDURES

PRECAUTIONS

1. Tape required:

(1) Blank tape			
MAXELL	UD-XL/I	(Normal)	
	UD-XL/II	(High)	
	MX	(Metal)	
(2) Test tape			
VICTOR	VTT-658	10 kHz, -15 dB	
TEAC	MTT-111	3 kHz, -10 dB	
	MTT-150	Dolby level calibration tone.	

2. Instrument required:

- (1) AC VTVM
- (2) Frequency counter
- (3) AF oscillator
- (4) Attenuator

3. The switches and controls should be set as follows unless otherwise specified.

Tape selector switch :	Normal
Dolby NR switch :	Out
Accubias adjust :	Center

1. PLAY BACK MODE ADJUSTMENT

1-1 Head azimuth adjustment

PROCEDURES :

- 1) Play the 10 kHz portion of the test tape VTT-658 back. Adjust the head azimuth adjusting screw for maximum V.T.V.M. read.
- 2) If the peak output reads of the right and left channels are different, set the screw to obtain the mechanical center between the peaks.
- 3) After adjustment, lock the screw with bond.

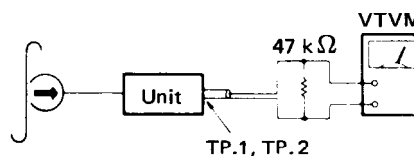

1-2 Tape speed adjustment

PROCEDURES :

Play the 3 kHz portion of the test tape MTT-111 back. Adjust the tape speed adjusting semi-fixed resistor in the motor for 3,000 to 3,010 Hz counter indication.

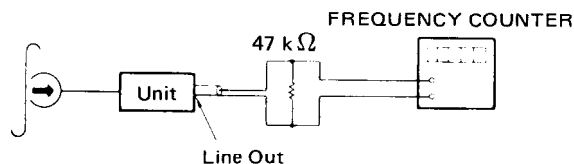

1-3 Playback output adjustment

PROCEDURES :

1) Play the test tape MTT-150 back, adjust R139 and R140 for 775 mV V.T.V.M. read

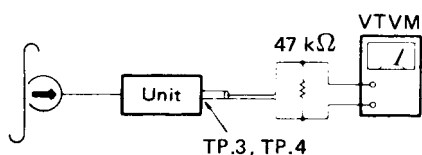

1-4 VU meter adjustment

PROCEDURES :

1) Play the test tape MTT-150 back.
2) Adjust R227 and R228 until the VU meter pointer deflects to the Dolby mark (∞, +3dB) on the meter.

2. RECORDING MODE ADJUSTMENT

2-1 Dolby circuit adjustment

PROCEDURES :

1) Connect the 5 kHz, 10 mV input signal to the line in terminal.
2) Connect the VTVM to the TP-1 terminal.
3) Set the tape deck in the recording mode of operation.
4) Adjust the input level volume for 23.5 mV VTVM read.
5) Turn the Dolby NR (MPX Filter) switch to ON.
6) Adjust R175 for 60 mV VTVM read.

2-2 Record bias adjustment

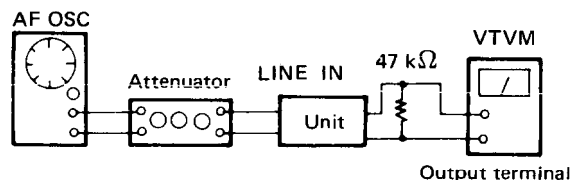

1) Press the pause key, and put the tape deck into recording mode. Apply a 400 Hz signal to the Line input terminals, and adjust the AF oscillator output so that the VU meter reads 0 VU.

2) Then set the input level to - 20 dB, and release the pause switch to record on the tape. Read the output level when this recording is played back again.
3) Next change the frequency of the oscillator to 8 kHz, and record again as described above. During playback of this recording, obtain the same output level as with the 400 Hz recording by readjusting R519 and R520

2-3 Record-playback output level adjustment

PROCEDURES:

1) Connect the 1 kHz input signal to the line in terminal.
2) Connect the VTVM to the output terminal.
3) Set the tape deck in the recording mode of operation.
* 4) Adjust the attenuator for 350mV VTVM read.
5) Set the deck in the playback mode of operation.
6) Adjust the R183 and R184 for 350 mV VTVM read.

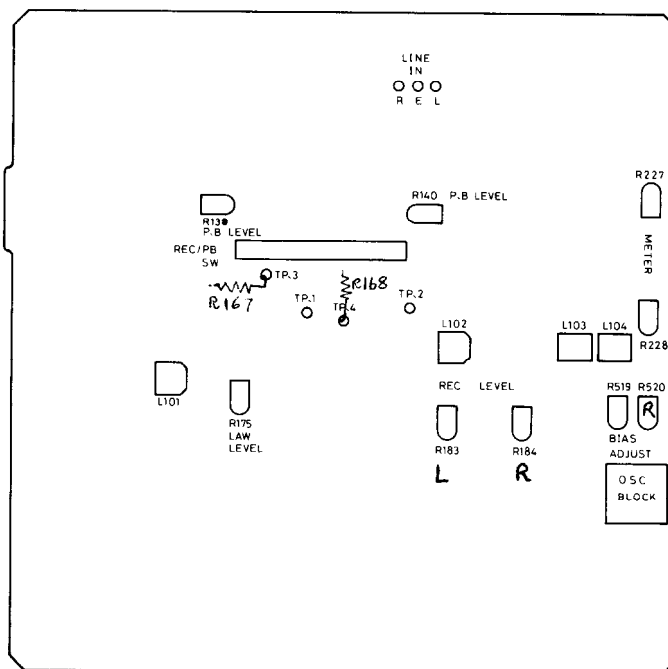

Adjustment point

EXPLODED VIEW

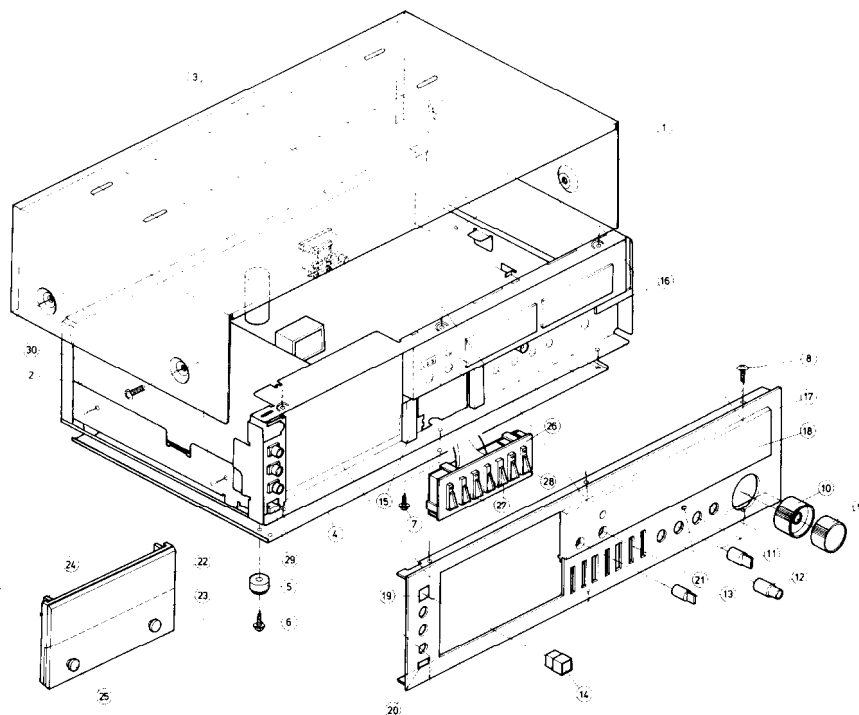

EXPLODED VIEW – PARTS LIST

Ref. No.	Part No.	Description
1	28184069	Top cover
2	838440109	4TTB + 10BC, Tap screw
3	28140106	55 x 10 x 2, Cushion
4	27170069	Bottom board
5	27175009	Leg
6	831130102	3STW + 10BQ, Tapping screw
7	831130082	3STW + 8BQ, Tapping screw
8	838130062	3STS + 6BQ, Tapping screw
9	28320393	Knob (L)
10	28320394	Knob (R)
11	28320424	Knob (SEL)
12	28320391	Knob (F)
13	28320388	Knob (M)
14	28320385	Knob (POW)
15	28140217	45 x 10 x 5 mm, Cushion
16	28140250	30 x 12 x 3 mm, Cushion
17	16359121	Front panel ass'y
18	28191049	Glass plate
19	27267062	Guide (POW)
20	27267061	Guide (E)
21	28198526	Facet
	27270042	Spacer
22	27300264	Cassette lid
23	27262054-1	Plate
24	27300265	Lid
25	870052	Washer
	801173B	Special screw
26	27267060	Guide (L)
27	28320389	Knob (P)
28	28320390	Knob (REC)
29	28320386A	Knob (EJECT)
	27180021	Spring
30	27120216	Back panel (120V model)
	27120217	Back panel (220V model)
	27120218	Back panel (120/220V model)
	27120230	Back panel (Australia model)

FEATURES

- Special Hard Permalloy Head Designed for Metal Tapes**
- Extremely Quiet and Accurate 2-Motor DD-Motor Drive**
The integrated motor/flywheel DD motor drive mechanism featured in the TA-2050 is particularly effective in reducing level deviations, intermodulation distortion, and wow and flutter.
- Dolby Noise Reduction System and MPX Filter**
- Peal Level Meters**
Accurate indication of the rapidly changing peak level values enables recording levels to be set far more precisely than average-level reading VU meters.
- ACCUBIAS Adjust System**
- Feather-Touch Controls Plus Electronic Logic**
- Audio Timer Start**
- Fade Out Mechanism**
This convenient function enables the end of recorded tapes to be erased gradually for smooth fade outs instead of the sudden cut-offs experienced when the program does not fit on the tape. Note that this is an independent control designed to avoid accidental use.
- Remote Control Unit Terminal**
- 3-Step Eq/Bias Tape Selector**
- Convenient Memory Operation**
The memory stop and memory play mechanism is particularly useful for repeated play of any desired tune, and also for checks of just-recorded programs.

SERVICE PROCEDURES

1. Removal the cassette lid

Press the STOP/EJECT key to open the cassette lid, then lift the door up and out to remove as illustrated below.

2. Cleaning and demagnetizing

Head cleaning

Sound quality is greatly influenced by accumulation of magnetic particles on the recording/playback head. For the clearest possible sound, be sure to clean the head periodically, normally 2 – 3 times a month. A dirty head will cause :

- Poor sound quality (loss of high sounds)
- Decreased volume
- Skipping
- Poor erasing (incomplete erasure of previous recording)

To prevent these problems, clean the head and capstan shaft with a cleaning pen or cotton swab dipped in a little alcohol.

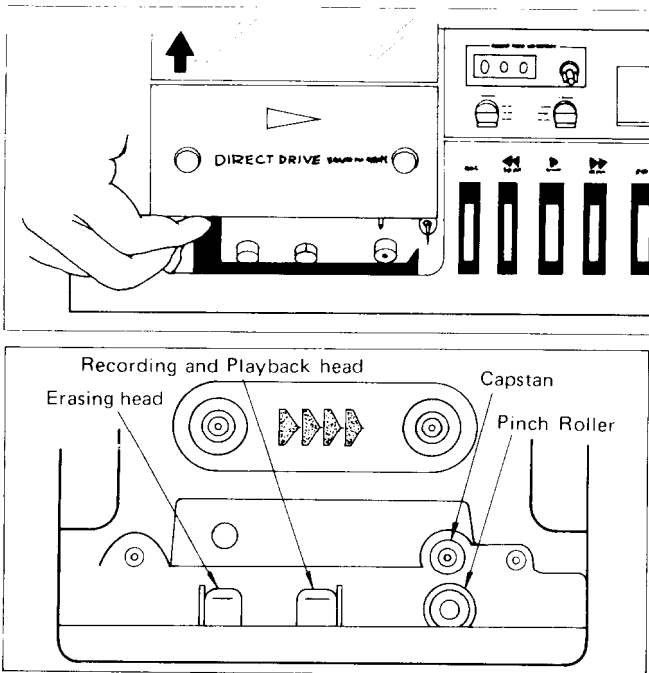

Pinch Roller Cleaning

If the pinch roller is dirty, the tape may become tangled and damaged by wrapping around the roller. Clean the pinch roller when cleaning the head. Use a special cleaner and cotton swab. Head cleaning materials must never be used for the pinch roller.

Demagnetizing

Residual magnetism builds up in the head after the cassette deck has been used for a long period of time. This build-up introduces noise and static into recording tapes and lowers the high frequency range. To prevent this, demagnetize the erasing and recording/playback head, as well as other affected metal parts (like the capstan shaft) once every 50

hours of use. Keep the tape deck power OFF while using the demagnetizer. Also place tapes far away from the work area.

3. Removal the front panel

Remove four screws which hold the top cover to side bracket and lift the top cover up. Remove five screws which hold the front panel to the front bracket.

4. Replacement of reel motor

- 1) Remove the printed circuit board (78).
- 2) Remove the three screws which hold the motor bracket (66) and the chassis (22).
- 3) Remove the two screws which hold the electromagnetic brake ass'y (63) and the reel platform case (64).
- 4) Replace the reel motor ass'y.

5. Replacement of drive motor

- 1) Remove the two screws which hold the cassette guide (30) and the cassette case (39).
- 2) Remove the screw (41) and Remove the cassette guide (30) and the cassette case (39) from the pin of side bracket.
- 3) Remove the printed circuit board (78).
- 4) Remove the two screws (83).

6. ACCUBIAS Adjust System

Although the tape deck is equipped with an ACCUBIAS system for fine bias adjustment, with most tapes you will get excellent results by just leaving the bias adjustment knob in the center clickstop position. Nevertheless, some tapes may require additional bias adjustment in order to give flat frequency response. In those cases, refer to the following diagram. For tapes not listed, use the 0 setting.

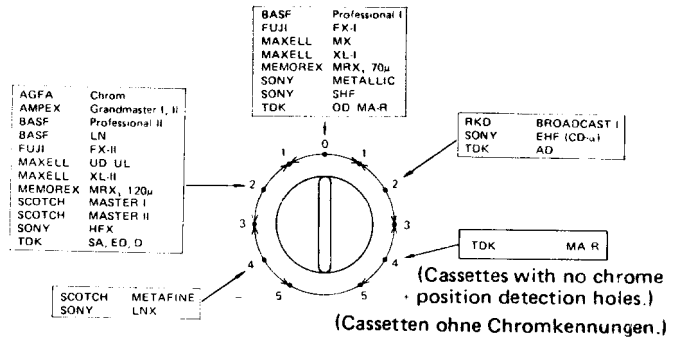

7. Fade Out Function

To fade out the sound at the end of a recording, depress the Fade Out control and turn it slowly clockwise as far as it will go. Fade out should be performed while listening to a tape so the speed of the fading out (i.e., rate at which the control is turned) can be matched to each tape.

PRECAUTIONS

1. AC Fuse

For continued protection against fire hazard, replace only with same type and same rating fuse.

Model	Parts No.	Description
120V	252045	1.0A (ST-6)
220V	252063	0.5A-SE-EAK
120/220V	252001	1A-T
240V	252063	0.5A-SE-EAK

2. Voltage selector (on Rear Panel)

Some units are equipped with a voltage selector. If the unit you own has a voltage selector, be sure it is set to the proper voltage before the power is turned on. To change the selector to conform to the power supply in your area, insert the tip of a screwdriver in the groove of the switch and slide it all the way to the left or right.

NOTE :

Units not equipped with a voltage selector can only be used in areas where the power supply agrees with the voltage specified on the rear panel.

MECHANISM OPERATION

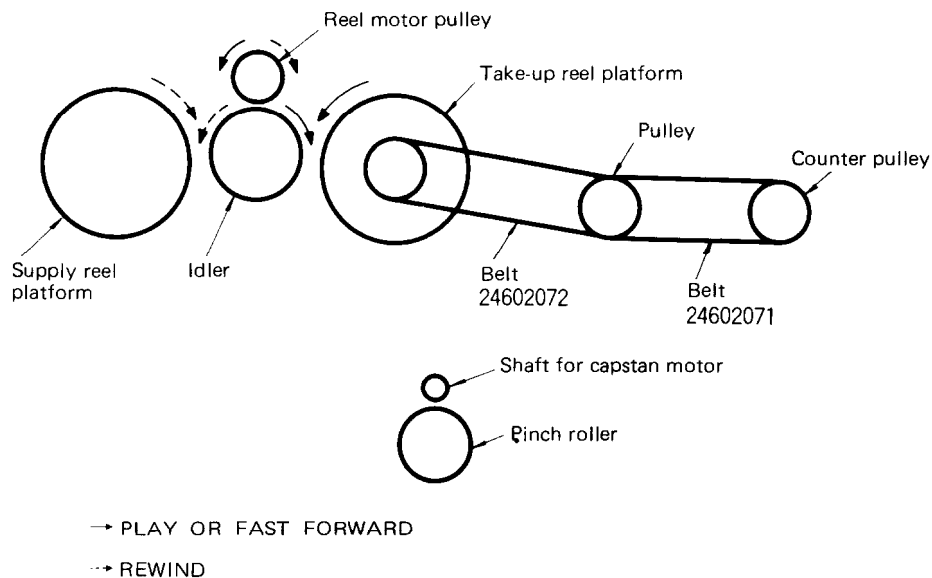

MECHANISM ADJUSTMENT

1. Hall IC clearance

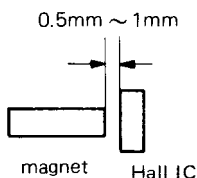

2. Current Consumption

	Reel motor		Capstan motor
PLAY	180 mA		110 mA
FF	110 mA		-
REW	110 mA		110 mA
AUTO	PLAY	190 mA	120 mA
STOP	FF. REW	120 mA	-

3. Play torque

- 1) Play the torque tape back.
- 2) Adjust R431 for 55g/cm to ~~60g~~g/cm torque tape indication.

4. Mechanism specifications

- 1) Tape speed : 4.8 cm/sec. (3kHz, 0, +10Hz)
Use a standard test tape, VTT-658 (3 kHz) or equipment
- 2) Wow and Flutter : Less than 0.045 % (WRMS)
- 3) Take-up torque : 55 – 60 gr-cm
- 4) F.F. torque : 60 – 130 gr-cm
- 5) Rewind torque : 60 – 130 gr-cm
- 6) Rewind time : 90 sec. (use a C-60 cassette tape)
- 7) Automatic shut-off time : Less than 3 sec.

MECHANISM EXPLODED VIEW

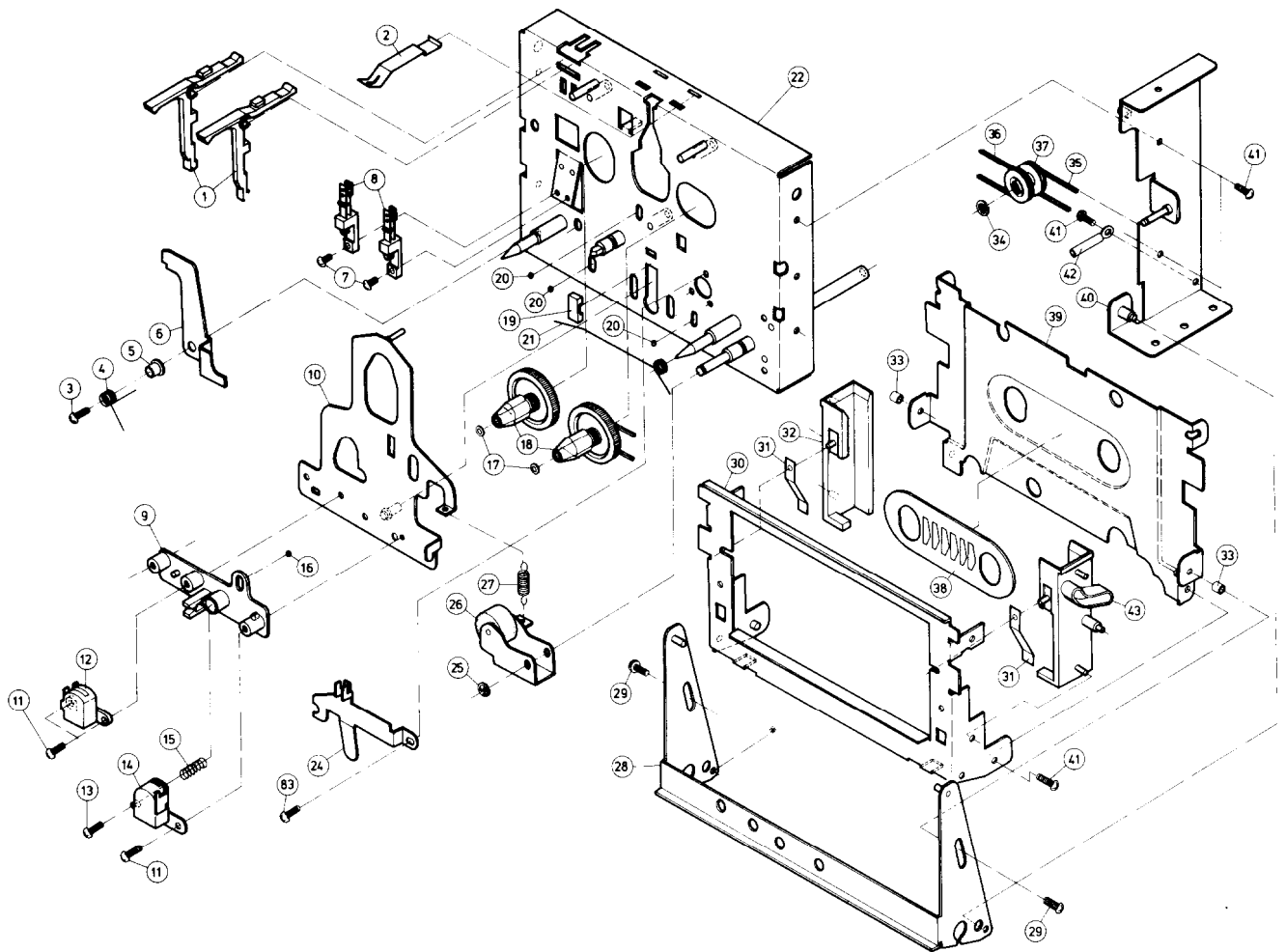

Ref No.	Parts No.	Description	Ref. No.	Parts No.	Description
1	24603130	Sensing lever	21	24605186	Spring
2	24605183	Cassette holding spring	22	24610352	Chassis
3	83312689	2.6 x 8, Pan head screw	23	801176	2.6 x 6, Pan head screw
4	24605184	Compression spring	24	24610353	Head holding plate
5	24610344	Collar	25	8930201	Circlip
6	24610345	Locked plate	26	24610354	Pinch roller arm ass'y
7	82112005	2 x 5, Pan head screw	27	24605187	Tension spring
8	24603128	Leaf switch	28	24610355	Loading mechanism ass'y
9	24610346	Head chassis	29	82112605	2.6 x 5, Pan head screw
10	24610347	Sub-chassis	30	24610356	Cassette guide ass'y
11	82512012	2 x 12, Binding screw	31	24605188	Spring
12	24660019	Erase head	32	24610357	Cassete holder (L)
13	801198	2 x 14, Pan head screw	33	24610358	Collar
14	24600018	Rec./pb. head	34	8930151	Circlip
15	24605185	Compression spring	35	24602071	Counter belt
16	24610348	Steelball	36	24602072	Reel belt
17	24610349	Plastic washer	37	24601051	Pulley
18	24602075	Reel ass'y	38	24610359	Plate
19	24610350	Stopper	39	24610360	Cassette back plate
20	24610351	Steelball	40	24610361	Side bracket

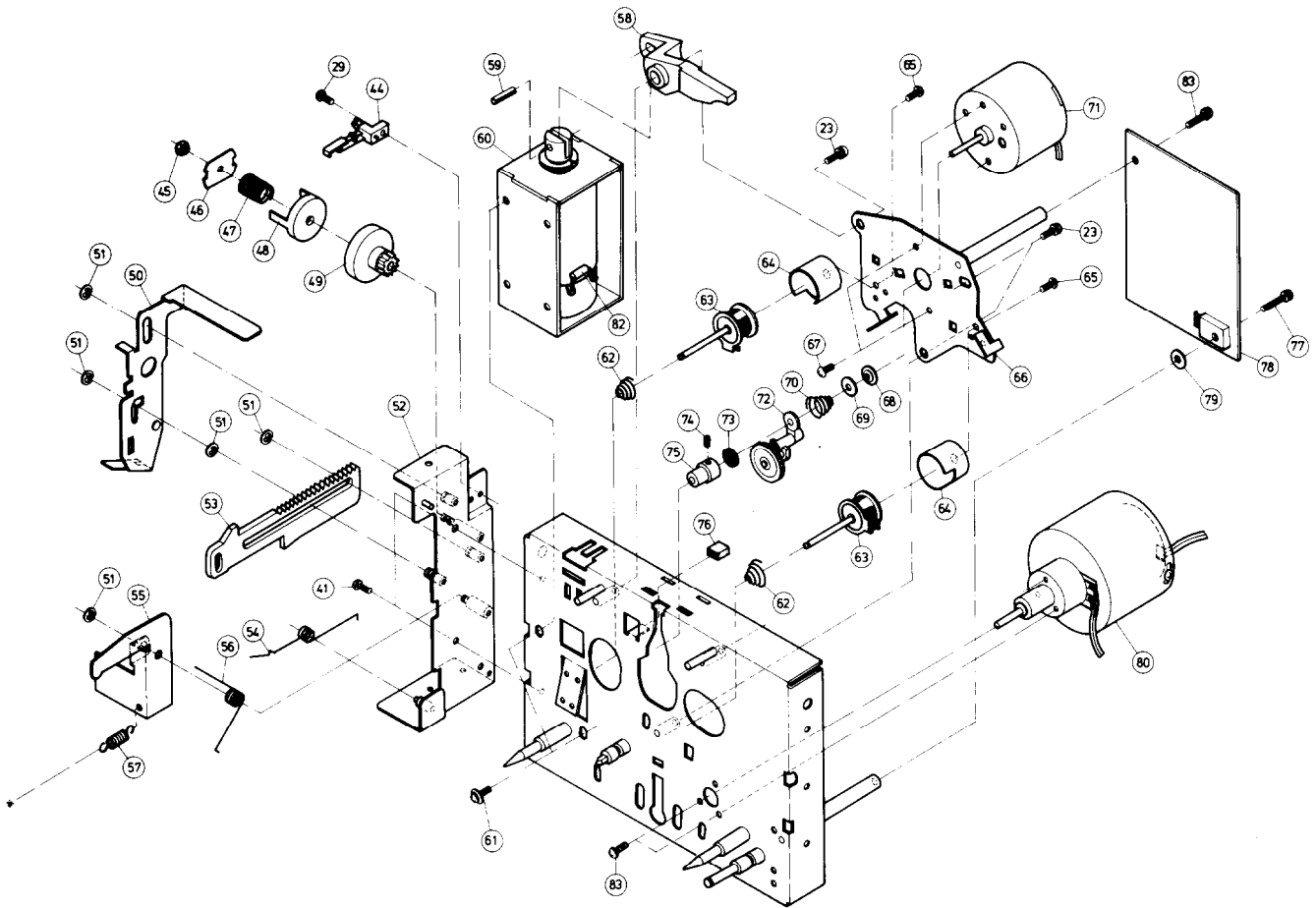

Ref. No.	Parts No.	Description
41	833126069	2.6 x 6, Pan head screw
42	24610362	Clamper
43	24610363	Holder (R)
44	24603129	Leaf switch
45	863120	Hexagon nut
46	24610364	Plate
47	24605189	Compression spring
48	24602073	Friction wheel
49	24602074	Gear
50	24610365	Eject lever
51	8930251	Circlip
52	24610366	Side bracket
53	24610367	Slider
54	24605190	Spring
55	24610368	Cancellation plate
56	24605191	Spring
57	24605192	Spring
58	24603131	Lever, head
59	24610369	Spring pin
60	24606098	Solenoid coil

Ref. No.	Parts No.	Description
61	801220	L=6, Pan head screw
62	24605193	Spring
63	24610370	Electro-magnetic brake ass'y
64	24610371	Reel platform
	24601056	Reel motor ass'y
65	82512004	2 x 4, Binding screw
66	24610372	Plate, motor holding
67	82512603	Binding screw
68	24610373	Receptacle for spring
69	24610374	Washer
70	24605194	Tension spring
71	24601054	Reel motor
72	24602076	Idler lever ass'y
73	24610375	Cushion
74	801221	2 x 2.5, Sems screw
75	24601052	Motor pulley
76	24610376	brake rubber
77	801187	2.6 x 8, Pan head screw
78	24606097	Printed circuit board
79	24601053	Insulator plate
80	24610337	Drive motor
82	24606099	Diode
83	801187	2.6 x 8, Pan head screw

SCHEMATIC DIAGRAM

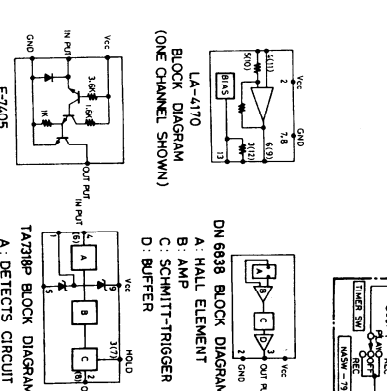
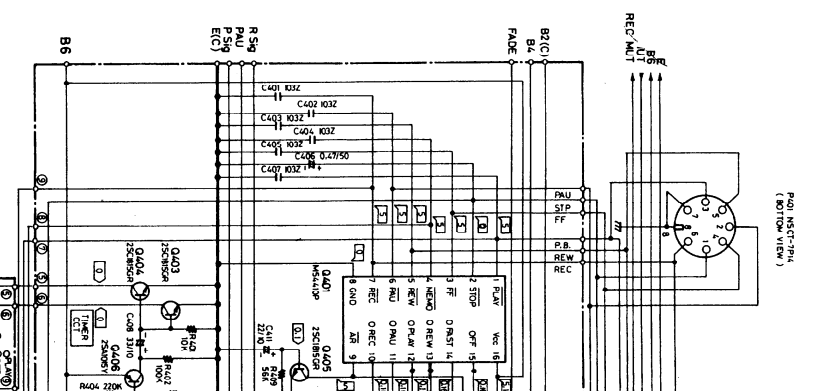
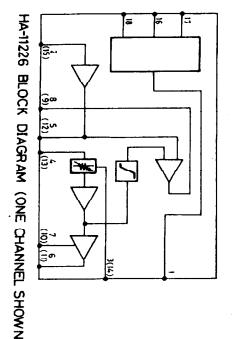
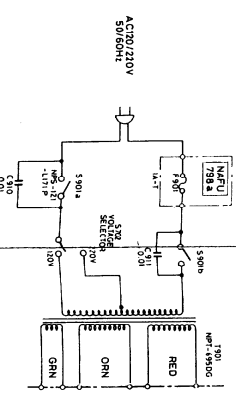
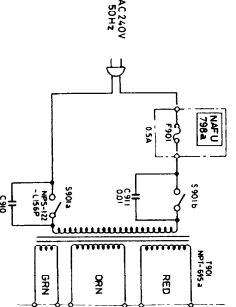
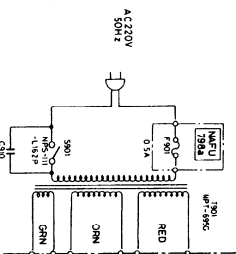
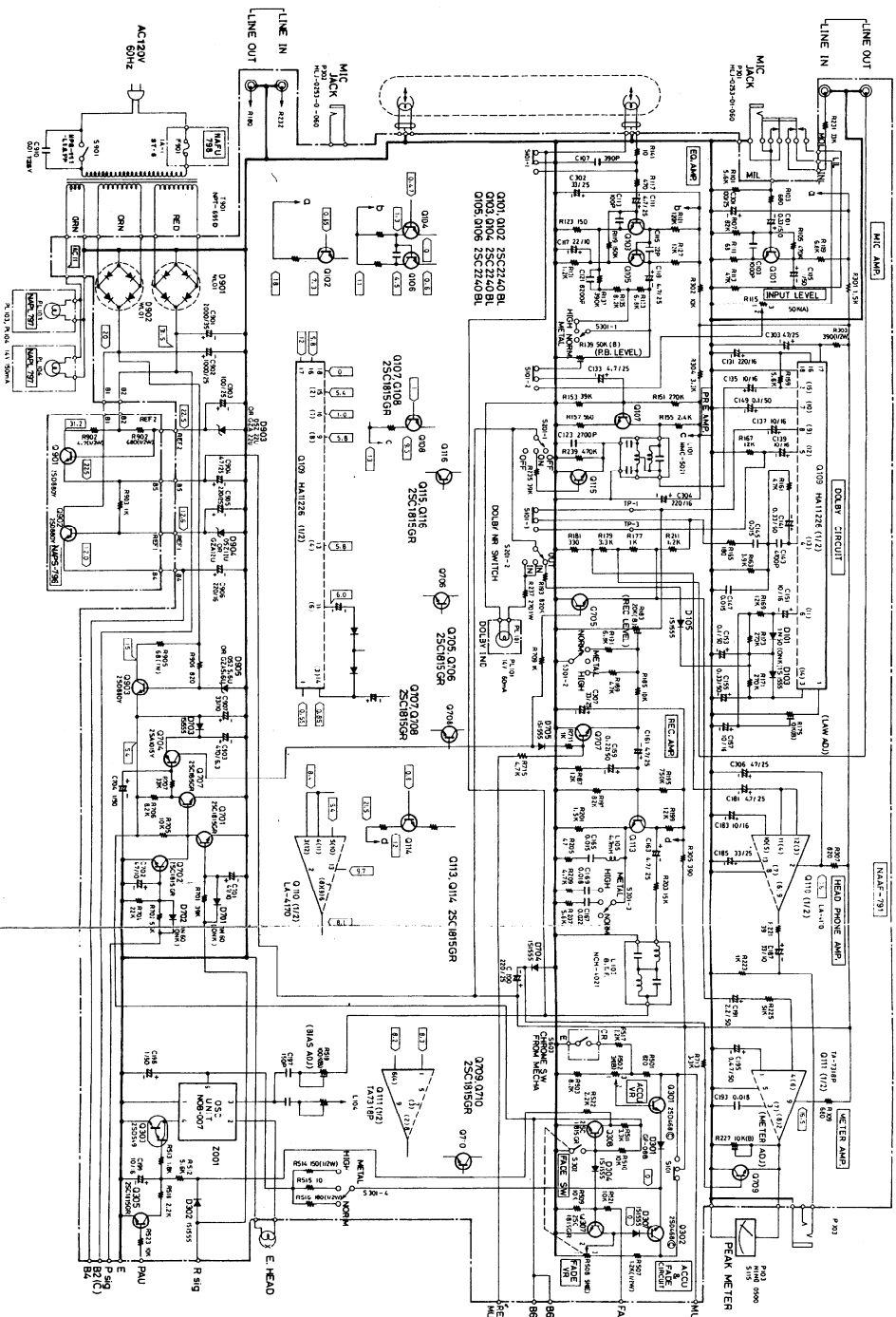

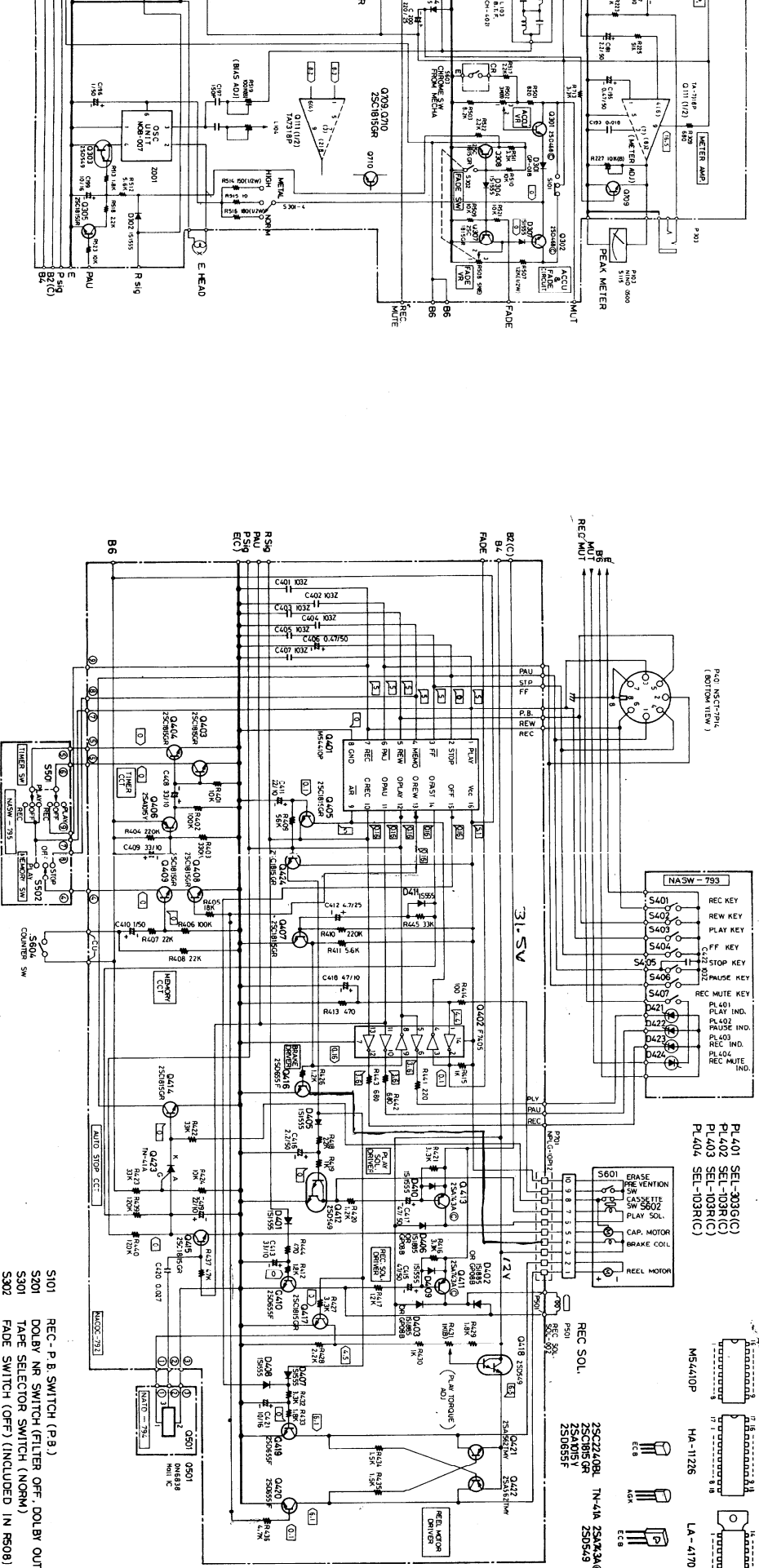

- PL401 SEL-303(C)
- PL402 SEL-103R(C)
- PL403 SEL-103R(C)
- PL404 SEL-103R(C)

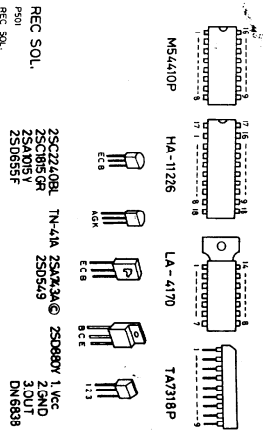

- S101 REC - P B SWITCH (P.B.)
- S201 DOLBY NR SWITCH (FILTER OFF, DOLBY OUT)
- S301 TAPE SELECTOR SWITCH (NORM)
- S302 FADE SWITCH (OFF) (INCLUDED IN R808)
- S801 TIMER SWITCH (OFF)
- S502 MEMORY SWITCH (OFF)
- S601 ERASE PREVISION SWITCH (OFF)
- S602 CASSETTE SWITCH (IN)
- S603 CHRM SW SWITCH (OFF)
- S604 COUNTER SWITCH (OFF) (INCLUDED IN COUNTER)

NOTE:

- ALL RESISTORS ARE IN OHMS 1/4 WATTS, UNLESS OTHERWISE NOTED.
- ALL CAPASITORS ARE IN μ F 50V, UNLESS OTHERWISE NOTED.
- ELECTROLYTIC CAPASITORS (- E -) ARE IN μ FW.
- VOLTAGE ARE MEASURED WITH V. T. V. M. WITH CASSETTE TAPE OUT. UNIT: VOLT.

ONKYO CORPORATION

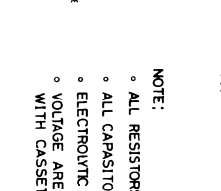
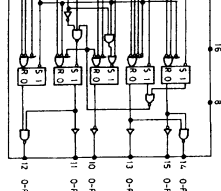
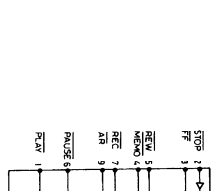
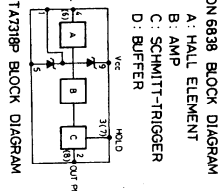
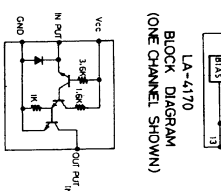
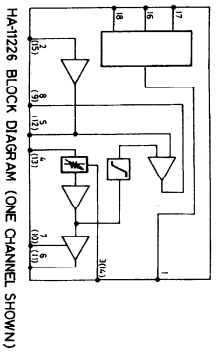

PRINED CIRCUIT BOARD-PARTS LIST

Rec. and playback amplifier pc board (NAAF-791) – Parts list

Circuit No.	Parts No.	Description
ICs		
Q109	222460	HA-11226
Q110	222543	LA-4170
Q111	222509	TA-7318P
Transistors		
Q101–Q106	2211406	2SC2240 (BL)
Q107, Q108	2211255	2SC1815 (GR)
Q113–Q116	2211255	2SC1815 (GR)
Q301, Q302	2211683	2SD468 (C)
Q303	2211952	2SC1472K (B)
Q305, Q307	2211255	2SC1815 (GR)
Q308		
Q701–Q703	2211255	2SC1815 (GR)
Q704	2211454	2SA1015 (Y)
Q705–Q710	2211255	2SC1815 (GR)
Q903	2201035	2SD325 (E)
Diodes		
D101, D102	223103	1N60
D103–D106	223133 or 223105	DS442X or 1S1555
D301	223848	GP-08B
D302, D304	223133 or 223105	DS442X or 1S1555
D307	223105	1S1555
D701, D702	223103	1N60
D703–D705	223133 or 223105	DS442X or 1S1555
D901, D902	223862	WL-01
D903	224124 or 224069	GZA22U or 05Z22U
D904	224112 or 224057	GZA12U or 05Z12U
D905	224096 or 224041	GZA5.6U or 05Z5.6U
Coils		
L101, L102	233221	NMC-5021
L103, L104	233146	NCH4021
L105, L106	24606072	NCH-1010
Oscillator block		
Z001	24606094	NOB-007
Resistors		
R115, R116	5104097	N16RKL50KA35F, Input level variable
R139, R140	5215023	N08HR50KBC, Playback level semi-fixed
R175	5215021	N08HR10KBC, Law level semi-fixed
R183, R184	5215022	N08HR20KBC, Recording level semi-fixed
R227, R228	5215021	N08HR10KBC, Meter adjustment semi-fixed
R502	5104098	N16RLC3KB15, Accubias variable
R508	5146018-1	N16RLS5KE20, Fade out variable
R514	441521514	150Ω, 1/2W, Metal oxide film
R516	441521814	180Ω, 1/2W, Metal oxide film
R519, R520	5215024	N08HR100KBC, Bias current semi-fixed
R905	441626804	68Ω, 1W, Metal oxide film
Capacitors		
C101, C102	392883397T	0.33 μF, 50V, LL
C105, C106	352780109T	1 μF, 50V, Elect.
C111, C112	392850477T	4.7 μF, 25V, LL
C117, C118	352732209T	22 μF, 10V, Elect.
C119, C120	352750479T	4.7 μF, 25V, Elect.
C131	352744719	470 μF, 16V, Elect.
C133, C134	392850477T	4.7 μF, 25V, LL
C135–C140	352741009T	10 μF, 16V, Elect.
C141, C142	392883397T	0.33 μF, 50V, LL

C149, C150	352781099T	0.1 μF, 50V, Elect.
C151, C152	352741009T	10 μF, 16V, Elect.
C153, C154	352781099T	0.1 μF, 50V, Elect.
C155, C156	352783399T	0.33 μF, 50V, Elect.
C157	352741009T	10 μF, 16V, Elect.
C159, C160	352782299T	0.22 μF, 50V, Elect.
C161, C162	352750479T	4.7 μF, 25V, Elect.
C163, C164	352780479T	4.7 μF, 50V, Elect.
C181, C182	352750479T	4.7 μF, 25V, Elect.
C183, C184	352741009T	10 μF, 16V, Elect.
C185	352753309T	33 μF, 25V, Elect.
C187, C188	352733309T	33 μF, 10V, Elect.
C191, C192	352780229T	2.2 μF, 50V, Elect.
C195	352784799T	0.47 μF, 50V, Elect.
C196	352780109T	1 μF, 50V, Elect.
C199	352741009T	10 μF, 16V, Elect.
C200	352752219	220 μF, 25V, Elect.
C301	352751019T	100 μF, 25V, Elect.
C302	352753309T	33 μF, 25V, Elect.
C303	352754709T	47 μF, 25V, Elect.
C304	352742219T	220 μF, 16V, Elect.
C306	352754709T	47 μF, 25V, Elect.
C307	352753309	33 μF, 25V, Elect.
C701, C702	352734709T	47 μF, 10V, Elect.
C703	352724719	470 μF, 6.3V, Elect.
C704	352780109T	1 μF, 50V, Elect.
C901	352762229	2,200 μF, 35V, Elect.
C902	352751029	1,000 μF, 25V, Elect.
C903	352751019T	100 μF, 25V, Elect.
C904	352754709T	47 μF, 25V, Elect.
C905	352752219	220 μF, 25V, Elect.
C906	352742219	220 μF, 16V, Elect.
C907	352733309T	33 μF, 10V, Elect.
Switches		
S101	25065087	R/P selector
S201	25030165	NRS-123-15U, Dolby
S301	25030148	NRS-183-15ZV, Tape selector
Terminal		
P101	25045020	NPJ4PDBL11, Input/output
Solenoid		
P501	24606092A	SOL-002
Lamp		
PL101	210086	PL14V60mA W 0.9
Switch circuit pc board (NASW-793) – Parts list		
Circuit No.	Parts No.	Description
L.E.Ds		
PL401	2250101	SEL-103R (C)
PL402	2250261	SEL-303G (C)
PL403, PL404	2250101	SEL-103R (C)
Switches		
S401-S407	25035089	NPS-111-S54
Auto stop circuit pc board (NATD-794) – Parts list		
Circuit No.	Parts No.	Description
Q501	222558	DN6838
Switch pc board (NASW-795) – Parts list		
S501, S502	25030149	NRS-123-20U, Timer, Memory
Power supply pc board (NAPS-796) – Parts list		
Q901, Q902	2201074	2SD880 (Y), Transistor
R901	441526814	680 Ω, 1/2W, Metal oxide film resistor
R902	451530474	4.7 Ω, 1/2W, Metal resistor
R904	441720104	1 Ω, 2W, Metal oxide film resistor
Lamp pc board (NAPL-797) – Parts list		
	210090	150 mA, 14V, Lamp

BLOCK DIAGRAM

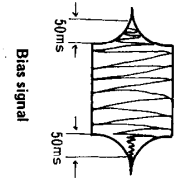
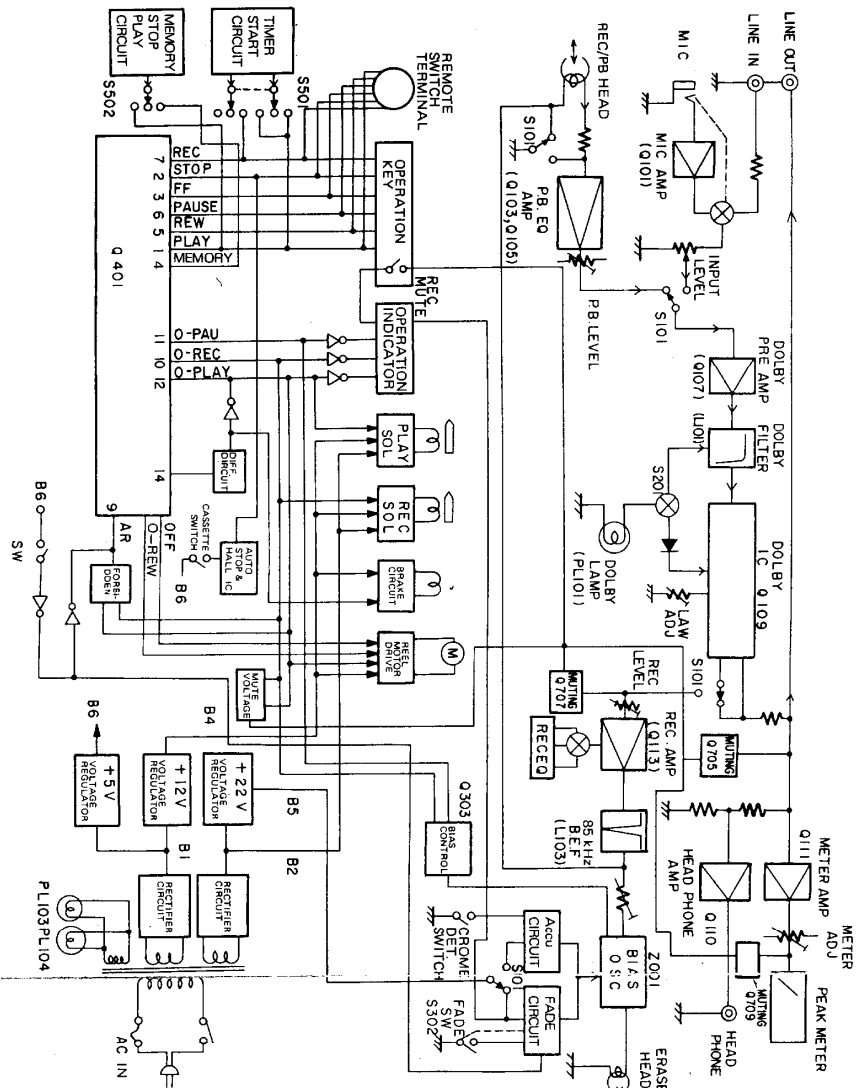

2. Bias Oscillator Circuit
 The circuit designed to prevent head magnetization incorporates a time constant circuit consisting of R512, R513 and C199 and which smooths out the rising and falling edges of the bias voltage when the recording switch is turned on and off.
 Q308 is used to ensure proper discharge of the C199 capacitor. Without this transistor, the C199 discharge would cause the bias voltage falling edge to become too long. If the recording switch was released within that time, the bias would be cut suddenly, resulting in magnetization of the head.

3. Reel Motor Drive Circuit
 Q419 and Q422 are turned on during fast forward mode, and Q420 and Q421 are likewise turned on during rewind mode, thereby passing current to the reel motor. Since the current passed to the motor during these two modes is applied in opposite directions the motor will also be rotated in opposite directions. The current applied during playback mode is passed in the same way as in fast forward mode, but in this case, Q417 is also turned on. R428 is thus short circuited, resulting in a drop in the supply voltage applied to the motor (approx. 3V). R431 is used to adjust the torque for playback mode.

4. Brake Circuit
 This circuit is designed to apply a current to the reel brake coil for 500 to 700 msec. whenever switching from fast forward mode to stop or playback modes, and from rewind mode to stop and playback modes. The application of this brake prevents the generation of tape slack.
 Operation Q407 is turned off and Q416 turned on whenever switching from fast forward or rewind mode to stop or playback mode, resulting in a current being passed to the brake coil.

CIRCUIT DESCRIPTIONS

1. FADE OUT circuit
 This circuit activates the bias oscillator during playback mode. The current passed through the erase head is varied by variable resistor, resulting in erasure of the recorded signal. The main conditions for fade out mode include (1) intact erasure prevention tabs in the cassette half, and (2) the tape deck be in playback mode.
 Operation Q307 is turned off when the FADE switch is pressed, and the voltage appearing at the emitter of Q302 when the FADE VR is turned becomes the B voltage for the OSC unit. At the same time, Q308 is turned off by the FADE switch, and Q303 turned on, resulting in the oscillator being activated. A current is thus passed through the erase head to start fade out mode.

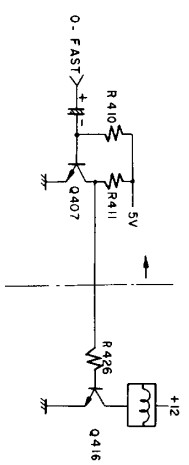
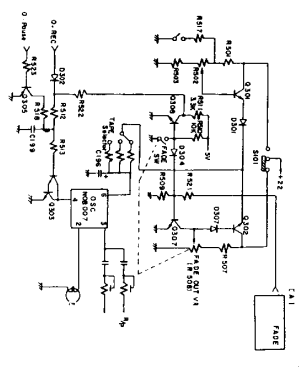

COMPONENT LOCATION

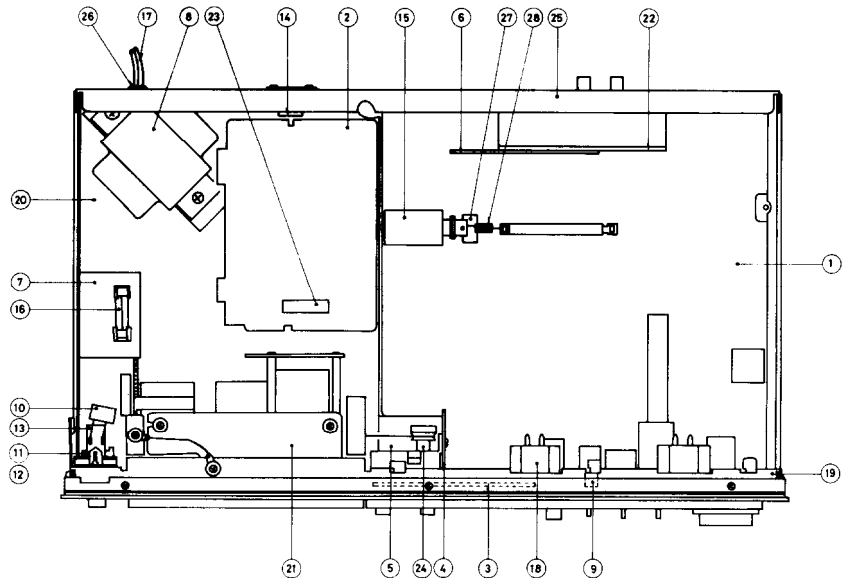

Component location – Parts list

120V model

Ref. Circuit No. No.	Parts No.	Description	4	U4	16398594	NATD-794, Auto-stop detector pc board
1	U1	16398591 NAAF-791, Rec./pb. amplifier pc board	5	U5	16398595	NASW-795, Switch pc board
2	U2	16398592 NACOC-792, Control circuit pc board	6	U6	16398596	NAPS-796, Power supply circuit pc board
3	U3	16398593 NASW-793, Switch circuit pc board	7	U8	16398598	NAFU-798, Fuse pc board (W model) NAFU-798A, Fuse pc board (G model)
4	U4	16398594 NATD-794, Auto-stop detector pc board	8	T901	230371	NPT-695G, Power transformer (G model)
5	U5	16398595 NASW-795, Switch pc board			230372	NPT-695DG, Power transformer (W model)
6	U6	16398596 NAPS-796, Power supply circuit pc board	9	PL101	210051	PL12V 30mAW1.5, Dolby indicator lamp
7	U8	16398598 NAFU-798, Fuse pc board	10	C910	3500058	PME265MB510, 0.01 μF, IS capacitor (G model)
8	T901	230370 NPT-695D, Power transformer		C910, C911	3500058	PME265MB510, 0.01 μF, IS capacitor (W model)
9	PL101	210051 PL12V 30 mAW 1.5, Dolby indicator lamp	11	P303	25045067	HLJ-0279-01-070, Stereo headphone jack
10	C910	3504012 ULCS125V 103M, ULCS capacitor	12	P301, P302	25045068	HLJ-0253-01-060, Microphone jack
11	P303	25045067 HLJ-0279-01-070, Stereo headphone jack	13	S901	25035198	NPS-111-L162P, Power switch (G model)
12	P301, P302	25045068 HLJ-0253-01-060, Microphone jack		S901	25035207	NPS-121-L171P, Power switch (W model)
13	S901	25035197 NPS-111-L161P, Power switch	14	P401	25050045	NSCT-7P-14, Remote switch terminal
14	P401	25050045 NSCT-7P-14, Remote switch terminal	15	P501	24606092	SOL-002, Solenoid coil
15	P501	24606092 SOL-002, Solenoid coil	16	F901	252001	0.5 A-SE-EAWK, AC fuse, (G model)
16	F901	252045 1.0A (ST-6), AC fuse,		F901	252001	1A-T, AC fuse (W model)
17		253099A AS-UC-3, Power supply cord	17		253083	AS-CEE, Power supply cord
18	P103, P104	243115 NIND-0500S115, Peak indicator meter	18	P103, P104	243115	NIND-0500S115, Peak indicator meter
19		27110099A Front bracket	19		27110099A	Front bracket
20		27100040A Chassis	20		27100040A	Chassis
21	Z001	244013 NDM-08, Tape mechanism ass'y	21	Z001	244013	NDM-08, Tape mechanism ass'y
22		27160046E Radiator	22		27160046E	Radiator
23		25050059 Socket ass'y	23		25050059	Socket ass'y
24		24601050 Counter	24		24601050	Counter
		28320387 Counter knob			28320387	Counter knob
25		27120216 Back panel	25		27120217	Back panel (G model)
26		270025 SR-3P-4, Strainrelief			27120228	Back panel (W model)
27		28140183 Cushion	26		270280	SR-4K-4, Strainrelief
28		27180050 Spring	27		28140183	Cushion
			28		27180050	Spring
				S902	25065123	NSS-1258P, Voltage selector (W model)

G/W model

Ref. Circuit No. No.	Parts No.	Description
1	U1	16398591 NAAF-791, Rec./pb. amplifier pc board
2	U2	16398592 NACOC-792, Control circuit pc board
3	U3	16398593 NASW-793, Switch circuit pc board

(W) : Only 120V/220V model
(G) : Only 220V model

PACKING PROCEDURES

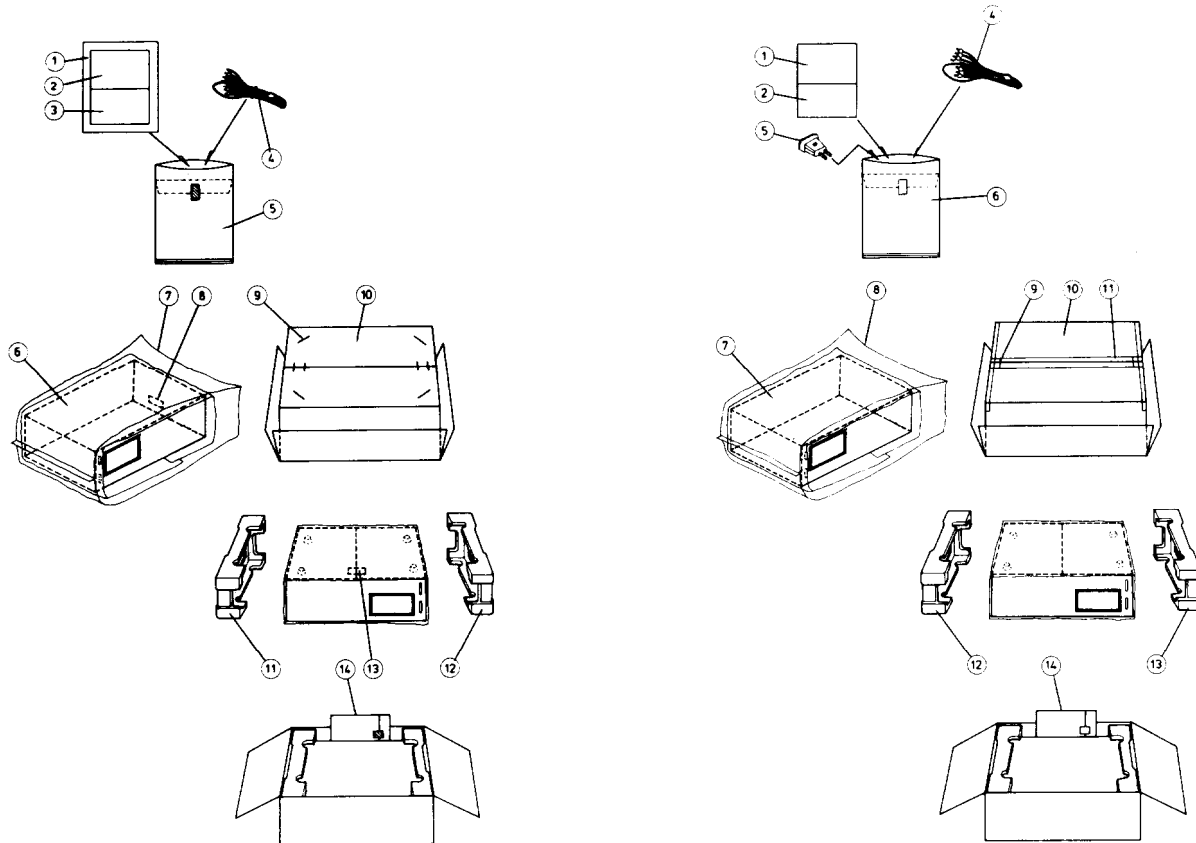

Ref. No.	Parts No.	Description
1	29340414	Instruction manual
2	29358002	Service station list (D)
3	29365006	Warranty card (D)
4	253074	Pin-pin connection cord
5	29100005	330 x 220 mm, Poly bag
6	29095064-1	400 x 900 mm, Protection sheet
7	29100037	650 x 500 mm, Poly bag
8	29360298	Label (D)
9	282301	Sealing hook
10	29050349	Carton box
11	29090480	Pad (R)
12	29090479	Pad (L)
13	293041	Caution label (D)
14		Accessory bag
	29095125	Protection sheet for door

(D) : Only U.S.A. model

Ref. No.	Parts No.	Description
1	29340415	Instruction manual
2	29365005-3	Warranty card (G)
4	253074	Pin-pin connection cord
5	25055018	Conversion plug (W)
6	29100006	330 x 250 mm, Poly bag
7	29095064-1	400 x 900 mm, Protection sheet
8	29100037	650 x 500 mm, Poly bag
9	282301	Sealing hook
10	29050349	Carton box
11	260012	Damplon tape
12	29090480	Pad (R)
13	29090479	Pad (L)
14		Accessory bag
	29095125	Protection sheet for door

(G) : Only Germany model

(W) : Only 120/220V model

ONKYO CORPORATION

International Division : No. 24 Mori Bldg., 23-5, 3-chome, Nishi-Shinbashi, Minato-ku, Tokyo, Japan
 Telex : 2423551 ONKYO J. Phone : 03-432-6981

ONKYO U.S.A. CORPORATION

Eastern Office
 42-07 20th Avenue, Long Island City, New York 11105, U.S.A. Phone : (212) 728-4639
 Midwest Office
 935 Sivert Drive, Wooddale, Illinois 60191, U.S.A. Phone : (312) 595-2970

ONKYO DEUTSCHLAND GMBH, ELECTRONICS

8034 München-Germering, Industriestrasse 18, West Germany. Telex : 521726 Telefon : (089)-84-5041