

ONKYO SERVICE MANUAL

STEREO CASSETTE TAPE DECK MODEL TA-2060

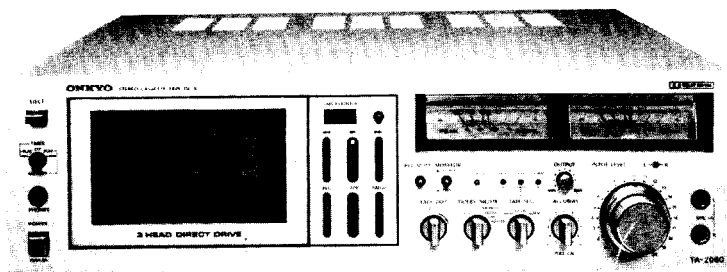

TABLE OF CONTENTS

Item	Page
Specifications	2
Features	3
Common modes of operation	3
Adjustment procedures	4
Service procedures	7
Exploded view	8
Mechanism-exploded view	9
Record and playback amplifier pc board view from bottom side (220V model)	11
Control pc board view from bottom side	14
Record and playback amplifier pc board view from bottom side (120V model)	15
Line amplifier pc board view from bottom side	18
Back tension and motor control pc board view from bottom side	19
Connection diagram for motor control pc board	19
Power supply pc board view from bottom side	20
Semi-conductor view	20
Component location	21
Packing procedures	22

ONKYO
AUDIO COMPONENTS

ADJUSTMENT PROCEDURES

PRECAUTIONS

1. Before adjustment, clean the following parts with an alcohol moistend swab.

- * record/playback head
- * erase head
- * pinch roller
- * capstan
- * rubber belt

2. Do not use magnetized screwdriver for adjustments.

3. Demagnetize record/playback head with a head demagnetizer.

4. The switches and controls should be set as follows unless otherwise specified.

TAPE SEL.	NORM
DOLBY NR/HX	OUT
FADE OUT	OUT
OUTPUT	MAX
INPUT LEVEL	0
ACCUBIAS	Center
TIMER/MEMORY	OFF

TEST EQUIPMENT/TOOLS REQUIRED:

Audio oscillator

Digital frequency counter

Oscilloscope

Attenuator

AC voltmeter

Non-magnetic screw drive

Blank tapes (completely erased)

NORMAL	UD-XL/ I
HIGH	UD-XL/ II
METAL	MX

Test tapes

VTT-658	: 10 kHz, -15 dB
MTT-111	: 3 kHz, -10 dB
MTT-150	: Dolby level calibration 400 Hz tone 200 nWb/m

TW-2111 : Torque meter

MC-12C or : Mirror tape

MC-9C

1. Hall IC position adjustment

Press the eject button to open the cassette lid, then lift the lid up and out to remove. Remove the two screws holding the cassette chassis and holder plate.

Adjust the clearance between the hall IC and magnet becomes 0.3 to 0.9 mm as shown below.

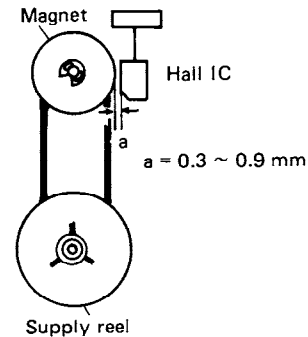

Fig. 1

2. Back tension adjustment

Play the torque meter TW-2111 back.

Adjust the VR21 on the motor control pc board so that the torque of supply reel hand becomes 3 to 6 gr-cm.

3. Play torque adjustment

Play the torque meter TW-2111 back.

Adjust the R721 so that the torque of take-up reel hand becomes 40 gr-cm.

4. Tape speed adjustment

Play the 3 kHz portion of the test tape MTT-111 back.

Adjust the VR1 on the motor control pc board so that the counter indication reads 3,000 Hz.

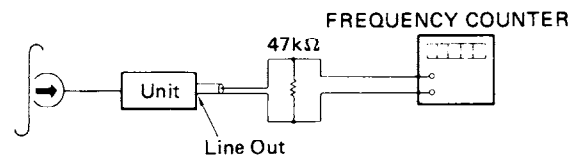

Fig. 2

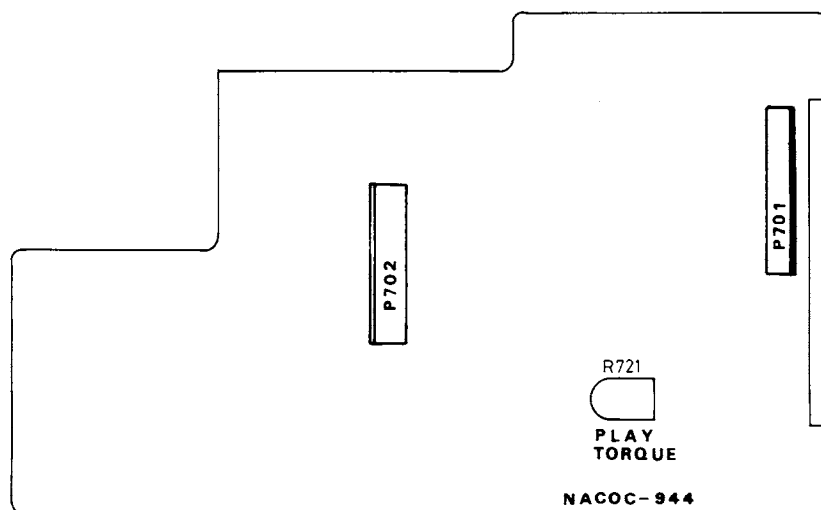

Fig. 3 Control pc board-adjustment point

5. Head azimuth adjustment

- 1) Play the test tape VTT-658 back.
- 2) Adjust the head azimuth screw (3) so that the phase relationship between L- and R-channels approximates 0 degrees as indicated on the oscilloscope.
- 3) At this time confirm that play back output level is approximately the maximum value on the AC voltmeter.
- 4) Then confirm that the phase difference of the respective frequency is within the rated value. 90 degrees or less in the range of 40 Hz to 10 kHz is required.
- 5) Secure the screw with the locking paint.

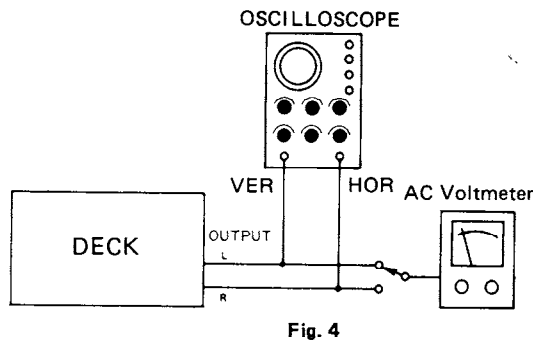

Fig. 4

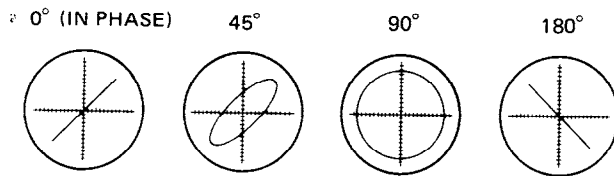

Fig. 5 Confirming phase relationship

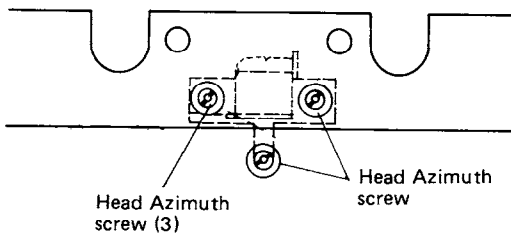

Fig. 6

Note: Perform the adjustment as shown below when the record/playback head is replaced.

1. Insert the mirror cassette tape into the cassette holder.
2. Play the mirror tape back.
3. Adjust the three azimuth screws so that the tape passes to the center of cassette guide as shown below.

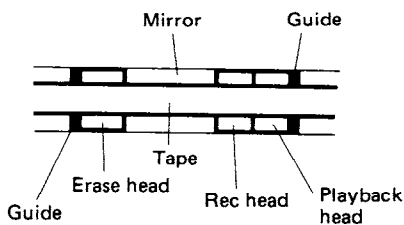

Fig. 7

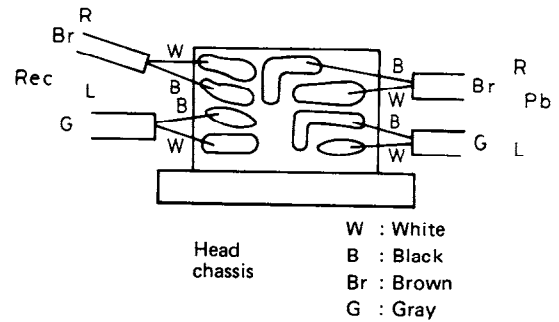

Fig. 8 Wiring view

4. Play the test tape VTT-658 back.
5. Adjust the head azimuth screws so that the AC voltmeter reads maximum.
6. Insert the normal blank tape into the cassette holder.
7. Apply the 10 kHz signal to the line-in terminals.
8. Set the monitor switch to the source position.
9. Adjust the AF oscillator output or input level volume so that the peak level meter reads 0VU.
10. Then set the attenuator for -10 dB input level, put the tape deck into the recording mode.
11. Set the monitor switch to the tape position.
12. Adjust the three azimuth screws so that the left and right channel outputs become the same and maximum level.

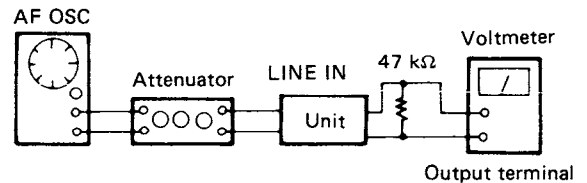

Fig. 9

6. Playback output adjustment

Play the test tape MTT-150 back. $TP3 \rightarrow TP4$
Adjust R119 and R120 so that the AC voltmeter reads 775 mV. 0vu meter reading

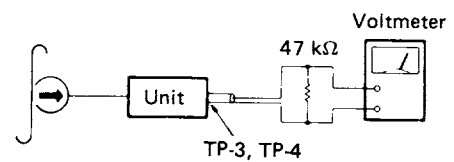

Fig. 10

7. Peak meter adjustment

- 1) Apply the 5 kHz signal to the line-in terminals.
- 2) Adjust the AF oscillator output or input level volume so that the AC voltmeter reads 1,100 mV.
- 3) Adjust the R341 and R342 so that the peak meter reads 0VU.

Note: Connect the test equipment as shown Fig. 9.

8. LAW adjustment

- 1) Connect the test equipment as shown in Fig. 10.
- 2) Apply the 5 kHz signal to the line-in terminals.
- 3) Set the monitor switch to the source position.
- 4) Adjust the attenuator so that the AC voltmeter reads 23.4 mV.
- 5) Connect the test equipment as shown in Fig. 11.
- 6) Turn the Dolby NR switch to the Dolby position.
- 7) Adjust the R351 and R352 so that the AC voltmeter reads 60 mV.

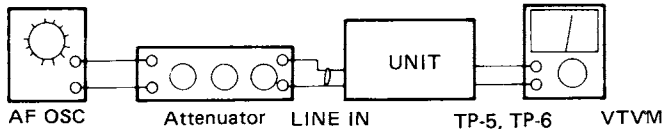

Fig. 11

9. Accubias adjustment

- 1) Pull out the auto accubias control knob and set the monitor switch to the source position.
- 2) Set the R517 and R516 to the position as shown below.

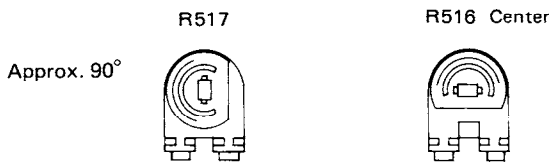

Fig. 12

- 3) Adjust the R516 so that the large indication of right channel meter becomes 0VU.
- 4) Adjust the R517 so that the meter of 333 Hz and 10 kHz indicates same calibration.
- 5) Adjust the R340 so that the meters of right and left channel indicate same calibration.
- 6) After adjustment, depress the accubias knob.

10. Record level and bias current adjustment

- 1) Insert the normal blank tape into the cassette holder.
- 2) Set the monitor switch to the source position.
- 3) Apply the 1,000 Hz signal to the line-in terminals.
- 4) Press the pause and record buttons and put the tape deck into recording mode.
- 5) Adjust the AF oscillator output or input level volume so that the VU meters read 0VU. (AC voltmeter reads 775 mV.)
- 6) Then set the attenuator so that the AC voltmeter reads 77.5 mV.
- 7) Release the pause button and record on the tape.
- 8) Set the monitor switch to the tape position.
- 9) Adjust the R263 and R264 so that AC voltmeter reads 77.5 mV. *20 dB Less (-20 dB)*
- 10) Next change the frequency of 400 Hz, and record again.
- 11) Read the output level when the monitor switch is set to the tape position.
- 12) Next change the frequency of the 10 kHz and record again.
- 13) Adjust the R574 and R575 so that the 400 Hz and 10 kHz levels become is same.

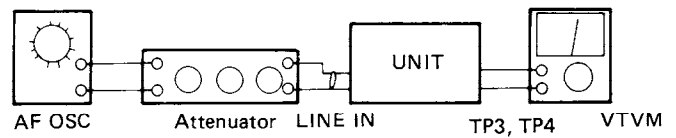

Fig. 13

11. Lid opening speed adjustment

Adjust the screw as shown below so that the lid opening speed becomes 0.3 to 2 sec.

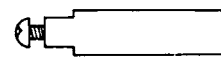

Fig. 14

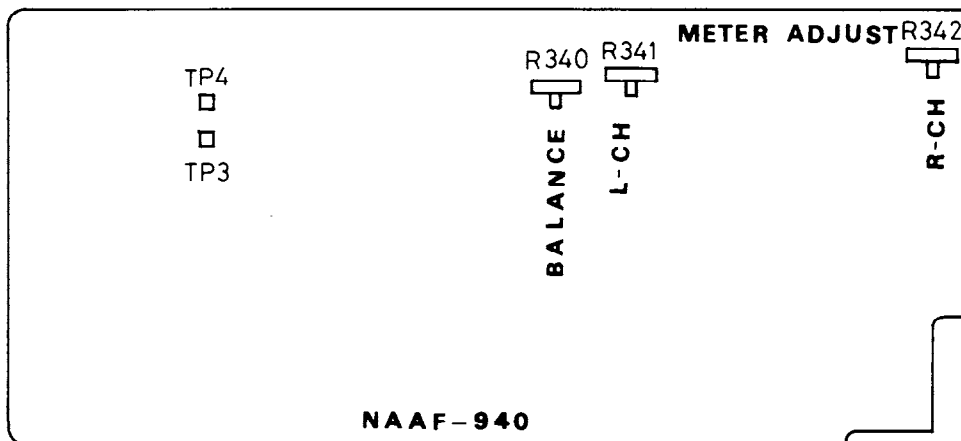
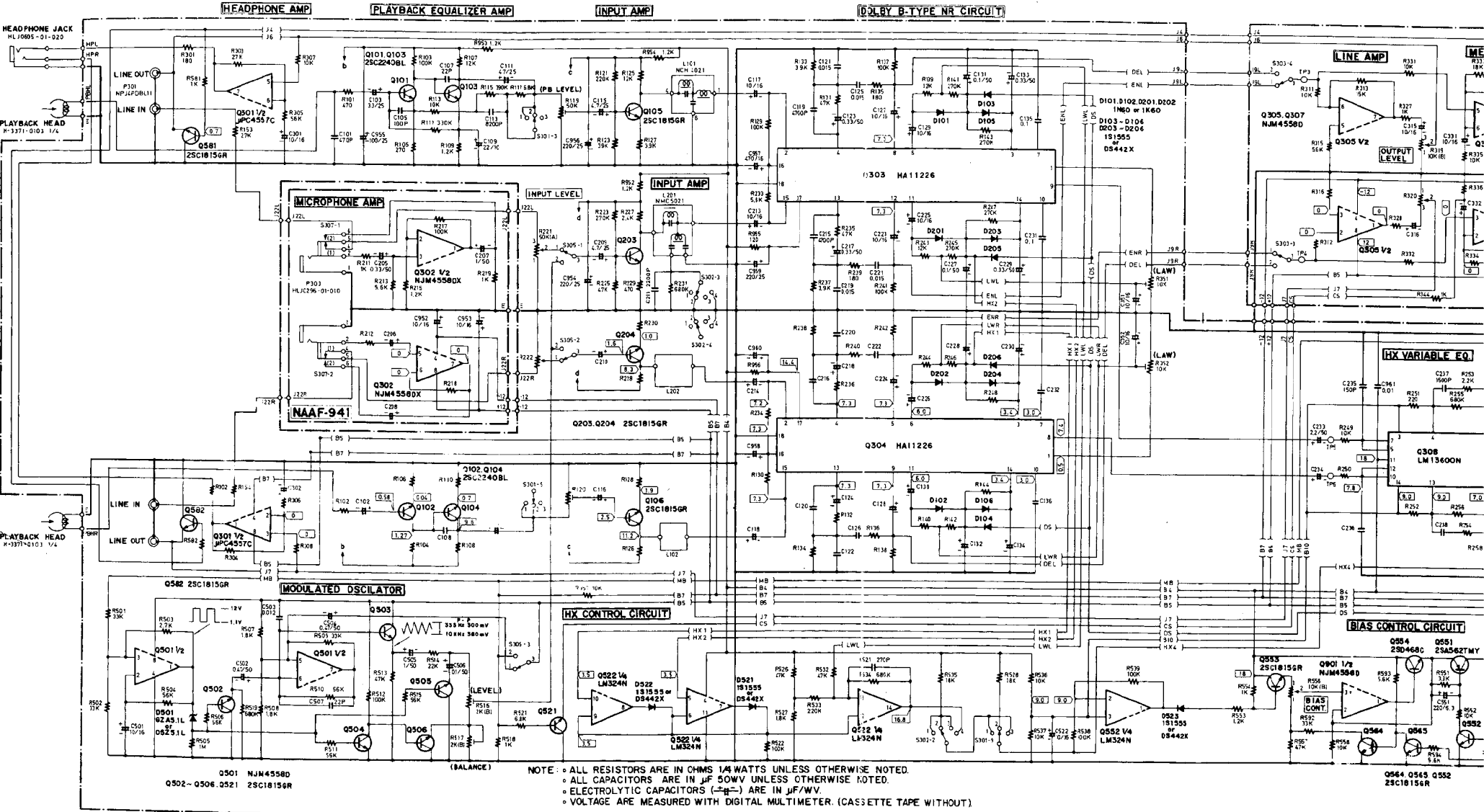
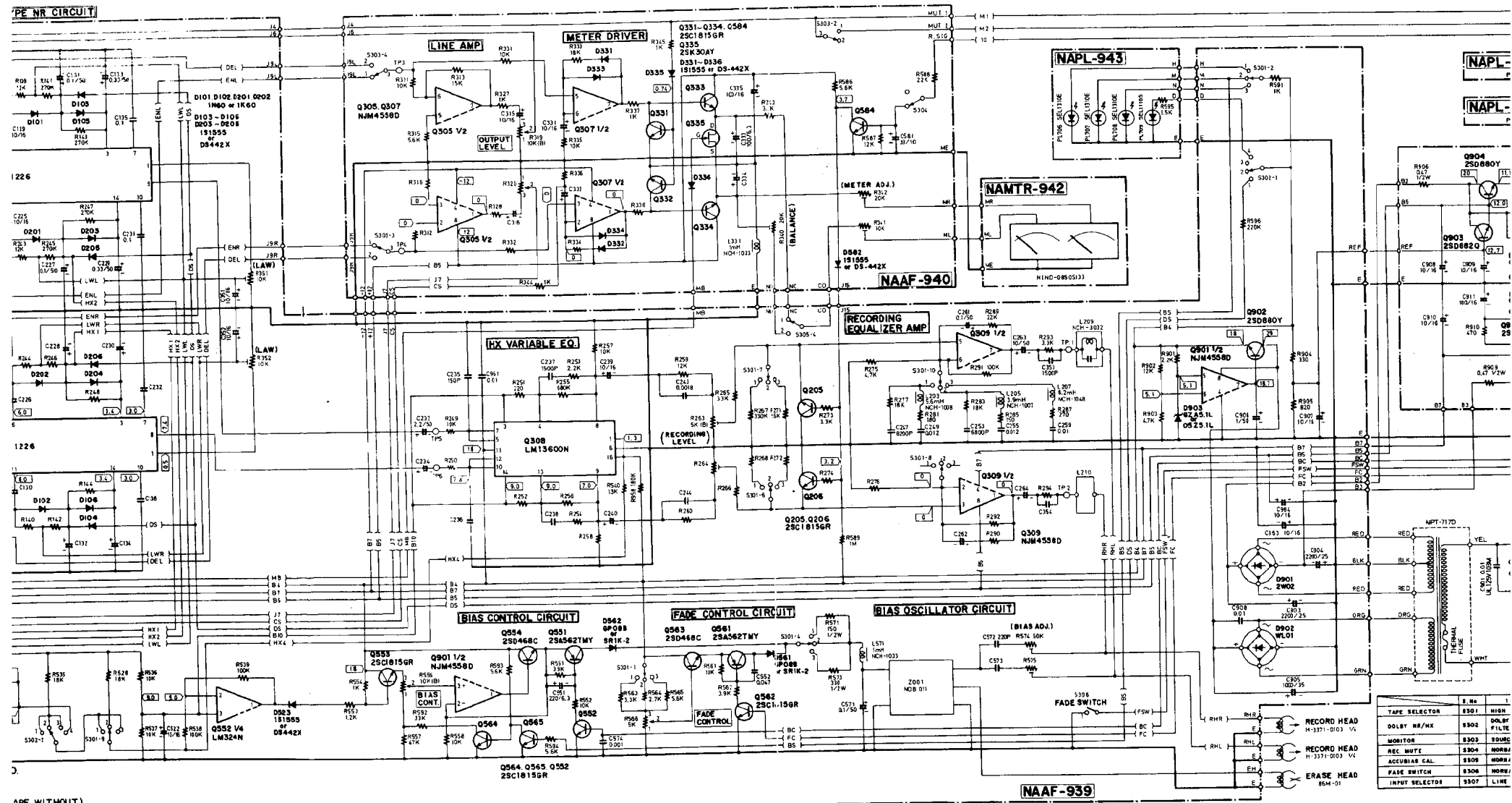

Fig. 15 Audio amplifier and meter drive pc board-adjustment points



NOTE: • ALL RESISTORS ARE IN OHMS 1/4 WATTS UNLESS OTHERWISE NOTED.
 • ALL CAPACITORS ARE IN μF 50V UNLESS OTHERWISE NOTED.
 • ELECTROLYTIC CAPACITORS (E) ARE IN $\mu F/VV$.
 • VOLTAGE ARE MEASURED WITH DIGITAL MULTIMETER. (CASSETTE TAPE WITHOUT)

PE NR CIRCUIT



APE WITHOUT.)

	8 Pin	1 Pin
TAPE SELECTOR	8301	NIEN
DOLBY NR/NX	8302	DOLBY FILTE
MONITOR	8303	8306
REC MUTE	8304	NORMA
ACCURATE CAL.	8305	NORMA
FADE SWITCH	8306	NORMA
INPUT SELECTOR	8307	LINE

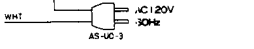
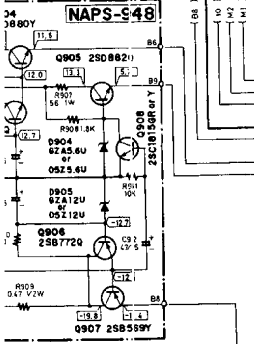
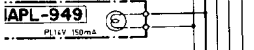
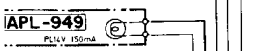
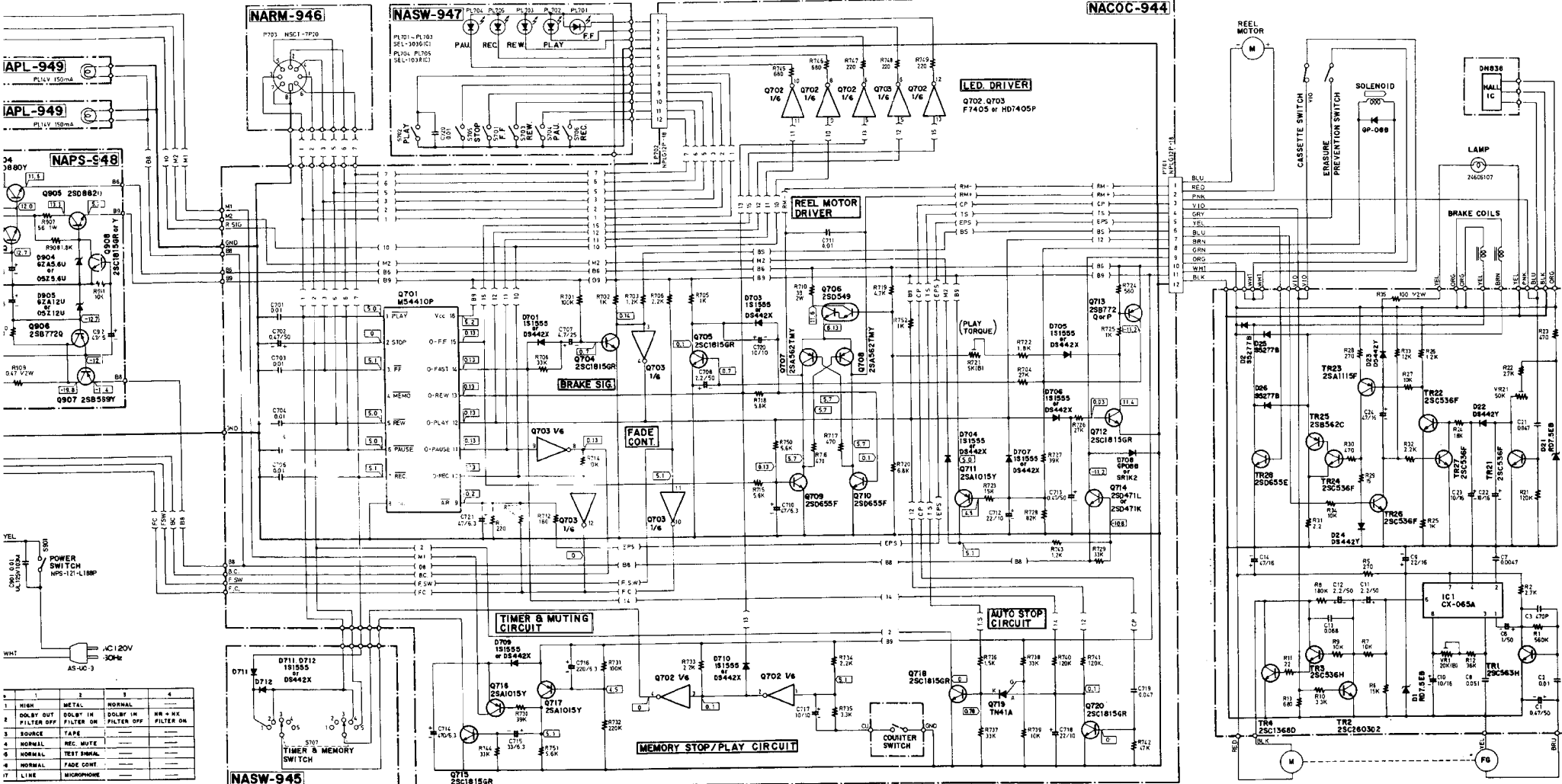

1	HIGH	METAL	NORMAL	
2	DOLBY OUT FILTER OFF	DOLBY IN FILTER ON	DOLBY IN FILTER OFF	NR + NR FILTER ON
3	SOURCE	TAPE		
4	NORMAL	REC. MUTE		
5	NORMAL	TEST SIGNAL		
6	NORMAL	FADE CONT.		
7	LINE	MICROPHONE		

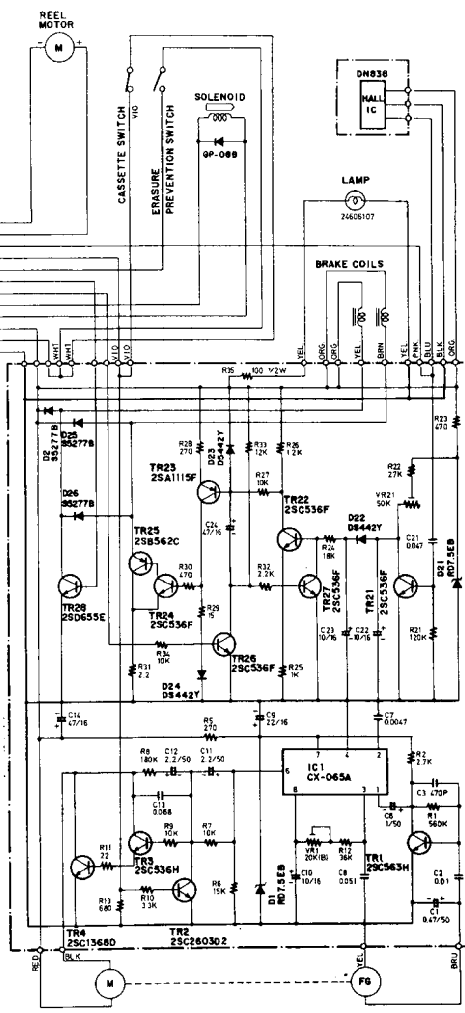

MECHANISM-EXPLODED VIEW

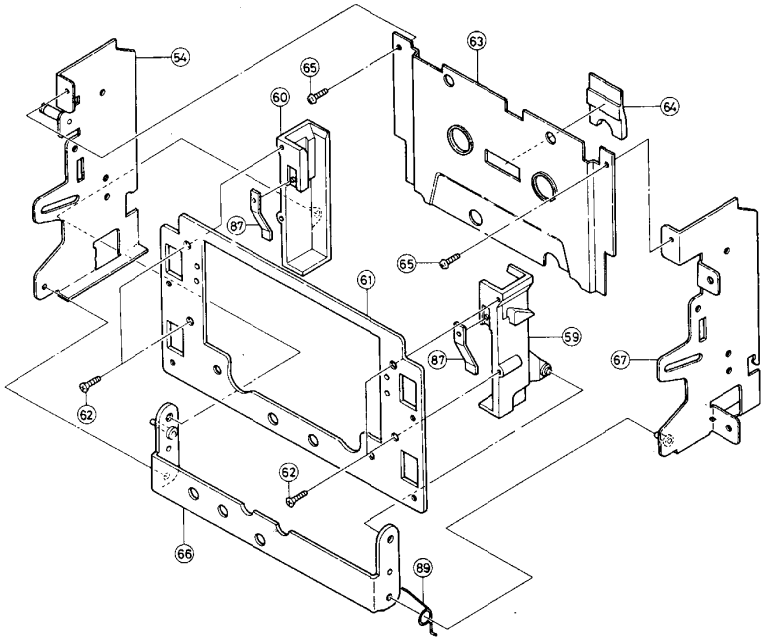
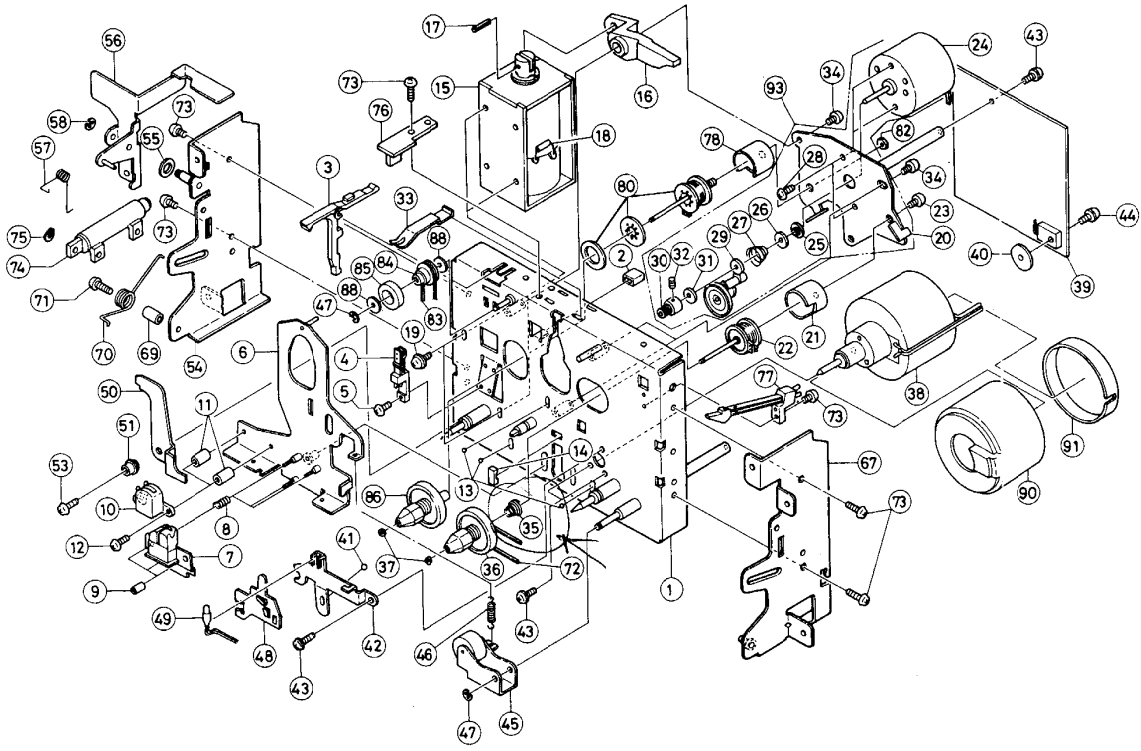

REF. NO.	PARTS NO.	DESCRIPTION
1	24610491	Chassis ass'y
2	24610376	Rubber, brake
3	24603130	Lever, chrome tape detector
4	24603128	Leaf switch, record preventing
5	82112004	M2x4, Pan head machine screw
6	24610492	Chassis, head
7	24600024	Head, record and playback
8	24605243	Spring
9	24610495	Nut, head azimuth
10	24600025	Erase head
11	24610493	Spacer
12	82512012	Bind screw
13	24610351	Steelball
14	24610350	Stopper
15	24606098	Solenoid
16	24603131	Lever, head
17	24610369	Pin, spring
18	223848	GP-08B, Diode
19	801220	M3x6, Pan head screw with spring washer
20	24610372	Bracket, motor
21	24610371	Case, reel platform
22	24610494	Bobbin ass'y

REF. NO.	PARTS NO.	DESCRIPTION
23	82512304	M2.3x4, Bind screw
24	24601054	Reel motor
25	24610373	Catcher, spring
26	24610374	Washer
27	24605194	Spring
28	82512603	M2.6x3, Bind screw
29	24602076	Lever, idler
30	24601052	Pulley, motor
31	24610375	Felt
32	801221	Screw
33	24605183	Spring, cassette holding
34	801176	Pan head screw
35	24605193	Spring
36	24602098	Take-up reel
37	24610349	Washer
38	24601055	Capstan motor
39	24606106	Motor and back tension control p.c.b.
40	24610377	Insulator washer
41	24610279	3φ, steelball
42	24610496	Plate, head pressure
43	801181	M2.6x6, Pan head screw
44	801178	M2.6x8, Pan head screw

REF. NO.	PARTS NO.	DESCRIPTION
45	24610497	Pinch arm ass'y
46	24605244	Spring
47	8930201	Circlip
48	24610498	Holder, lamp
49	24606107	50mA, 8V, Lamp
50	24610345	Lock plate
51	24610344	Collar
53	833125089	2.5x8, Pan head screw
54	24610499	Bracket, side
55	24610452	Washer
56	24610500	Lever, canceller
57	24605245	Spring
58	8930302	E3, Circlip
59	24610501	Holder, cassette
60	24610502	Holder, cassette
61	24610503	Mount plate
62	835426082	2.6x8, Tapping screw
63	24610504	Plate
64	24610505	Tube
65	833225059	Screw
66	24610506	Bracket ass'y, cassette holder
67	24610507	Bracket, side

REF. NO.	PARTS NO.	DESCRIPTION
69	24610516	Spacer
70	24605246	Spring
71	833130129	3x12, Pan head screw
72	24602099	Belt, counter
73	833125059	2.5x5, Pan head screw
74	24610508	Damper
75	24610514	Clip link
76	24606105	Hall IC p.c.b.
77	24606104	Leaf switch
78	24610509	Case, reel platform
79	24610519	Bracket ass'y
80	863730	M3, Nut
81	24602100	Belt
82	24602101	Pulley
83	24610512	Magnet
84	24602102	Reel, supply
85	24605188	Spring
86	24610515	φ2.5, washer
87	24605247	Spring
88	24610517	Cap
89	24610518	Cap
90	24610515	Cap
91	24601055	Reel motor/Idler ass'y (20, 24~32)

RECORD AND PLAYBACK AMPLIFIER PC BOARD (NAAF-939a) – PARTS LIST

CIRCUIT NO.	PARTS NO.	DESCRIPTION	CIRCUIT NO.	PARTS NO.	DESCRIPTION
	ICs			Capacitors	
Q301	222603	μPC4557C	C227, C228	392881097	0.1μF, 50V, LL
Q303, Q304	222460	HA-11226	C229, C230	392883397	0.33μF, 50V, LL
Q308	222602 or 222617	LM13600N or NE5517N	C231, C232	384121044	0.1μF±2%, 50V, DT
Q309, Q501	222465	NJM4558D	C233, C234	352780229	2.2μF, 50V, Elect.
Q522	222604	LM324N	C237, C238	379121524	1.500pF±5%, 50V, DEW
Q901	222465	NJM4558D	C239, C240	352741009	10μF, 16V, Elect.
	Transistors		C243, C244	379121824	1,800pF±5%, 50V, DEW
Q101–Q104	2211406	2SC2240(BL)	C249, C250	379121234	12,000pF±5%, 50V, DEW
Q105, Q106	2211255	2SC1815(GR)	C255, C256	379121234	12,000pF±5%, 50V, DEW
Q151, Q152	2210274	2SK30A(Y), F.E.T	C259, C260	379121034	10,000pF±5%, 50V, DEW
Q201, Q202	2211406	2SC2240(BL)	C261, C262	352781099	0.1μF, 50V, Elect.
Q203–Q206	2211255	2SC1815(GR)	C263, C264	352781009	10μF, 50V, Elect.
Q502–Q506	2211255	2SC1815(GR)	C301, C302	352741009	10μF, 16V, Elect.
Q521	2211255	2SC1815(GR)	C351, C352	352741009	10μF, 16V, Elect.
Q551, Q561	2211554	2SA562TM(Y)	C501	352741009	10μF, 16V, Elect.
Q552, Q553	2211255	2SC1815(GR)	C502	352784799	0.47μF, 50V, Elect.
Q554	2211683	2SD468(C)	C503	379121234	0.012μF±5%, 50V, DEW
Q562	2211255	2SC1815(GR)	C504	352784799	0.47μF, 50V, Elect.
Q563	2211683	2SD468(C)	C505	352780109	1μF, 50V, Elect.
Q564, Q565	2211255	2SC1815(GR)	C506	352781099	0.1μF, 50V, Elect.
Q581–Q583	2211255	2SC1815(GR)	C522	352741009	10μF, 16V, Elect.
Q902	2201074	2SD880(Y)	C551	352722219	220μF, 6.3V, Elect.
	Diodes		C552	379124734	0.047μF±20%, 50V, DEW
D101, D102	223103 or 223132	1N60 or 1K60	C571	352781099	0.1μF, 50V, Elect.
D103–D106	223105 or 223133	1S1555 or DS-442X	C903, C904	352752229	2,200μF, 25V, Elect.
D151, D152	223133	DS-442X	C905	352761029	1,000μF, 35V, Elect.
D201, D202	223103 or 223132	1N60 or 1K60	C906	352780109	1μF, 50V, Elect.
D203–D206	223105 or 223133	1S1555 or DS-442X	C907, C951	352741009	10μF, 16V, Elect.
D501	224038 or 224093	05Z5.1L or GZA5.1L	C954, C956	352752219	220μF, 25V, Elect.
D521–D523	223105 or 223133	1S1555 or DS-442X	C955	352751019	100μF, 25V, Elect.
D561, D562	223804 or 223848	SR1K-2 or GP08B	C957, C958	352744719	470μF, 16V, Elect.
D901	223868	2W02	C959, C960	352752219	220μF, 25V, Elect.
D902	223862	WL-01	C963, C964	352741009	10μF, 16V, Elect.
D903	224038 or 224093	05Z5.1L or GZA5.1L			
	Coils		Resistors		
L101, L102	233146	NCH4021	R119, R120	5215023	N08HR50KBC, Semi-fixed
L201, L202	233221	NMC5021	R221, R222	5104106	N16RKL50KA40F, Variable
L203, L204	24606070	NCH-1008	R263, R264	5215020	N08HR5KBC, Semi-fixed
L205, L206	24606069	NCH-1007	R351, R352	5215021	N08HR10KBC, Semi-fixed
L207, L208	24606108	NCH-1048	R516, R517	5215019	N08HR2KBC, Semi-fixed
L209, L210	233186	NCH-3032	R556	5104105	N16RLS10KB20M, Variable
L571	233188	NCH-1033	R566	5104107	N16RLS5K20M, Variable
	Oscillator block		R571	441521514	150Ω, ½W, Metal oxide film
Z001	24606103	NOB-011	R573	441523314	330Ω, ½W, Metal oxide film
	Capacitors		R574, R575	5215023	N08HR50KBC, Semi-fixed
C103, C104	392850337	3.3μF, 25V, LL			
C109, C110	352732209	22μF, 10V, Elect.			
C111, C112	352750479	4.7μF, 25V, Elect.			
C113, C114	379128224	8,200pF±5%, 50V, DEW			
C115, C116	392850477	4.7μF, 25V, LL			
C117, C118	352741009	10μF, 16V, Elect.			
C119, C120	384124723	4,700pF±2%, 50V, DT			
C121, C122	384121533	15,000pF±2%, 50V, DT			
C123, C124	392883397	0.33μF, 50V, LL			
C125, C126	384121533	15,000pF±2%, 50V, DT			
C127–C130	352741009	10μF, 16V, Elect.			
C131, C132	392881097	0.1μF, 50V, LL			
C133, C134	392883397	0.33μF, 50V, LL			
C135, C136	384121044	0.1μF±5%, 50V, DT			
C201, C202	392880107	1μF, 50V, LL			
C203, C204	352780109	1μF, 50V, Elect.			
C209, C210	392850477	4.7μF, 25V, LL			
C213, C214	352741009	10μF, 16V, Elect.			
C215, C216	384124723	4,700pF±2%, 50V, DT			
C217, C218	392883397	0.33μF, 50V, LL			
C219–C222	384121533	15,000pF±2%, 50V, DT			
C223, C224	352741009	10μF, 16V, Elect.			
C225, C226	352741009	10μF, 16V, Elect.			
				Switches	
			S301	25030174	NRSM-1103-20SS, Tape selector
			S302	25030173	NRSM-144-20SS, Dolby NR
				Terminal	
			P301	25045020	NPJ-4PDBL11, Tape input/output
				Socket	
			P302	25050064	NSCT5P18, DIN
				Radiator	
				27160029	
				Lead wires	
			J9	79119	JL-4-290-5-5-P2.5
			J16	79124	JL-5-110-5-5-P2.5
			J18	79120	JL-5-140-5-5-P2.5
			J21	79118	JL-4-160-5-5-P2.5
			J22	79122	JL-4-145-5-5-P2.5
				Screws	
				831130082	3STW+8BQ, Tapping
				82113006	3P+6FN, Pan head
				Plates	
				27300130	Ground
				28175032	Insulator

CIRCUIT NO.	PARTS NO.	DESCRIPTION
	ICs	
Q701	222555	M54410P
Q702, Q703	222556	HD7405P or F7405
	Transistors	
Q704, Q705	2211255	2SC1815(GR)
Q706	2201060	2SD549
Q707, Q708	2211554	2SA562TM(Y)
Q709, Q710	2211706	2SD655(F)
Q711	2211454	2SA1015(Y)
Q712	2211255	2SC1815(GR)
Q713	2201275 or 2201276	2SB772(Q) or 2SB772(R)
Q714	2211612 or 2211611	2SD471(L) or 2SD471(K)
Q715	2211255	2SC1815(GR)
Q716, Q717	2211454	2SA1015(Y)
Q718, Q720	2211255	2SC1815(GR)
Q719	2211571	TN41A, F.E.T
	Diodes	
D701, D703	223105 or	1S1555 or
D704-D707	223133	DS-442X
D708	223804 or	SR1K-2 or
	223848	GP08B
D709, D710	223105 or	1S1555 or
	223133	DS-442X

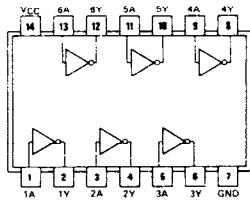

HD7405, F7405

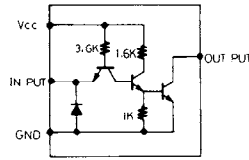

7405
SCHEMATIC DIAGRAM
(ONE CIRCUIT SHOWN)

CIRCUIT NO.	PARTS NO.	DESCRIPTION
	Capacitors	
C702	352784799	0.47 μ F, 50V, Elect.
C707	352750479	4.7 μ F, 25V, Elect.
C708	352780229	2.2 μ F, 50V, Elect.
C710	352724709	47 μ F, 6.3V, Elect.
C712	352732209	22 μ F, 10V, Elect.
C713	352784799	0.47 μ F, 50V, Elect.
C714	352724719	470 μ F, 6.3V, Elect.
C715	352723309	33 μ F, 6.3V, Elect.
C716	352722219	220 μ F, 6.3V, Elect.
C717	352731009	10 μ F, 10V, Elect.
C718	352732209	22 μ F, 10V, Elect.
C720	352731009	10 μ F, 10V, Elect.
C721	352724709	47 μ F, 6.3V, Elect.
	Resistors	
R710	442722704	27 Ω , 2W, Metal oxide film
R721	5215020	N08HR5KBC, Semi-fixed
	Plugs	
P701, P702	25065133	NPLG-12P-18
	Lead wires	
J1	79118	JL4-160-5-5-P2.5
J6	79120	JL5-220-5-5-P2.5

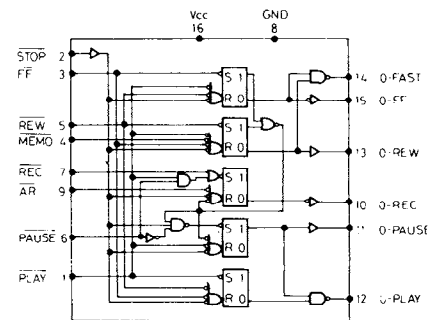

M54410P BLOCK DIAGRAM

TA-2060 BLOCK DIAGRAM

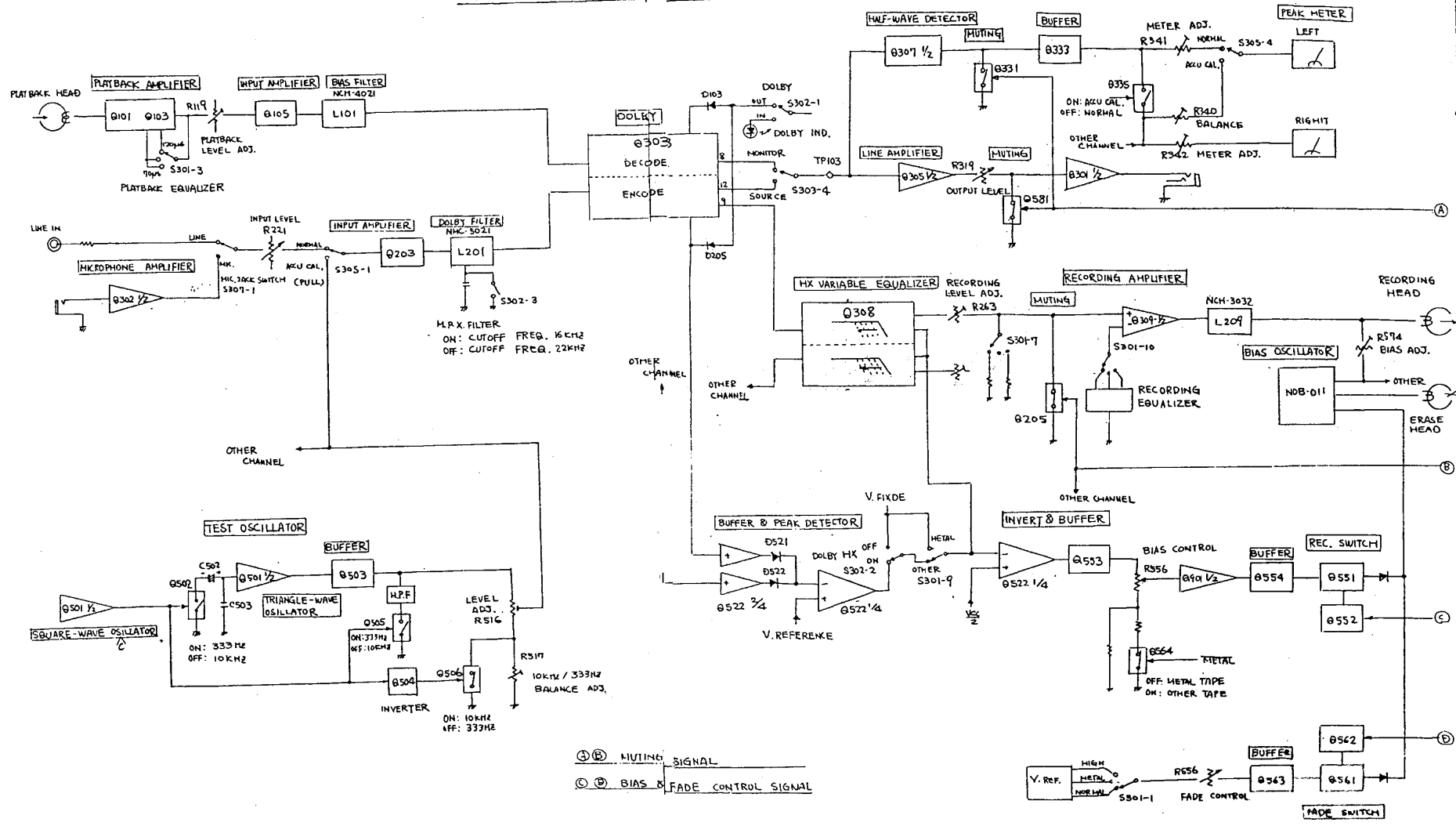

RECORD AND PLAYBACK AMPLIFIER PC BOARD (NAAF-939) – PARTS LIST

CIRCUIT NO.	PARTS NO.	DESCRIPTION	CIRCUIT NO.	PARTS NO.	DESCRIPTION
	ICs			Capacitors	
Q301	222603	μ PC4557C	C237, C238	379121524	1,500pF \pm 5%, 20V, DEW
Q303, Q304	222460	HA-11226	C239, C240	352741009	10 μ F, 16V, Elect.
Q308	222602 or	LM13600N or	C243, C244	379121824	1,800pF \pm 5%, 50V, DEW
	222617	NE5517N	C249, C250	379121234	12,000pF \pm 5%, 50V, DEW
Q309, Q501	222465	NJM4558D	C255, C256	379121234	12,000pF \pm 5%, 50V, DEW
Q522	222604	LM324N	C259, C260	379121034	10,000pF \pm 5%, 50V, DEW
Q901	222465	NJM4558D	C261, C262	352781099	0.1 μ F, 50V, Elect.
	Transistors		C263, C264	352781009	10 μ F, 50V, Elect.
Q101–Q104	2211406	2SC2240(BL)	C301, C302	352741009	10 μ F, 16V, Elect.
Q105, Q106	2211255	2SC1815(GR)	C351, C352	352741009	10 μ F, 16V, Elect.
Q203–Q206	2211255	2SC1815(GR)	C501	352741009	10 μ F, 16V, Elect.
Q502–Q506	2211255	2SC1815(GR)	C502	352784799	0.47 μ F, 50V, Elect.
Q521	2211255	2SC1815(GR)	C503	379121234	0.012 μ F \pm 5%, 50V, DEW
Q551, Q561	2211554	2SA562TM(Y)	C504	352784799	0.47 μ F, 50V, Elect.
Q552, Q553	2211255	2SC1815(GR)	C505	352780109	1 μ F, 50V, Elect.
Q554	2211683	2SD468(C)	C506	352781099	0.1 μ F, 50V, Elect.
Q562	2211255	2SC1815(GR)	C522	352741009	10 μ F, 16V, Elect.
Q563	2211683	2SD468(C)	C551	352722219	220 μ F, 6.3V, Elect.
Q564, Q565	2211255	2SC1815(GR)	C552	379124734	0.047 μ F \pm 20%, 50V, DEW
Q581, Q582	2211255	2SC1815(GR)	C571	352781099	0.1 μ F, 50V, Elect.
Q902	2201074	2SD880(Y)	C903, C904	352752229	2,200 μ F, 25V, Elect.
	Diodes		C905	352761029	1,000 μ F, 35V, Elect.
D101, D102	223103 or	1N60 or	C906	352780109	1 μ F, 50V, Elect.
	223132	1K60	C907	352741009	10 μ F, 16V, Elect.
D103–D106	223105 or	1S1555 or	C954, C956	352752219	220 μ F, 25V, Elect.
	223133	DS-442X	C955	352751019	100 μ F, 25V, Elect.
D201, D202	223103 or	1N60 or	C957, C958	352744719	470 μ F, 16V, Elect.
	223132	1K60	C959, C960	352752219	220 μ F, 25V, Elect.
D203–D206	223105 or	1S1555 or	C963, C964	352741009	10 μ F, 16V, Elect.
	223133	DS-442X			
D501	224038 or	05Z5.1L or	R119, R120	5215023	N08HR50KBC, Semi-fixed
	224093	GZA5.1L	R221, R222	5104106	N16RKL50KA40F, Variable
D521–D523	223105 or	1S1555 or	R263, R264	5215020	N08HR5KBC, Semi-fixed
	223133	DS-442X	R351, R352	5215021	N08HR10KBC, Semi-fixed
D561, D562	223804 or	SR1K-2 or	R516, R517	5215019	N08HR2KBC, Semi-fixed
	223848	GP08B	R556	5104105	N16RLS10KB20M, Variable
D901	223868	2W02	R566	5104107	N16RLS5K20M, Variable
D902	223862	WL-01	R571	441521514	150 Ω , 1/2W, Metal oxide film
D903	224038 or	05Z5.1L or	R573	441523314	330 Ω , 1/2W, Metal oxide film
	224093	GZA5.1L	R574, R575	5215023	N08HR50KBC, Semi-fixed
	Coils			Resistors	
L101, L102	233146	NCH4021	S301	25030174	NRSM-1103-20SS, Tape selector
L201, L202	233221	NMC5021	S302	25030173	NRSM-144-20SS, Dolby NR
L203, L204	24606070	NCH-1008			
L205, L206	24606069	NCH-1007			
L207, L208	24606108	NCH-1048	P301	25045020	NPJ-4PDBL11, Tape input/output
L209, L210	233186	NCH-3032			
L571	233188	NCH-1033			
	Oscillator block			Radiator	
Z001	24606103	NOB-011		27160029	
	Capacitors			Lead wires	
C103, C104	392850337	3.3 μ F, 25V, LL	J9	79119	JL4-290-5-5-P2.5
C109, C110	352732209	22 μ F, 10V, Elect.	J16	79124	JL5-110-5-5-P2.5
C111, C112	352750479	4.7 μ F, 25V, Elect.	J18	79120	JL5-140-5-5-P2.5
C113, C114	379128224	8,200pF \pm 5%, 50V, DEW	J21	79118	JL4-160-5-5-P2.5
C115, C116	392850477	4.7 μ F, 25V, LL	J22	79122	JL4-145-5-5-P2.5
C117, C118	352741009	10 μ F, 16V, Elect.			
C119, C120	384124723	4.700pF \pm 2%, 50V, DT			
C121, C122	384121533	15,000pF \pm 2%, 50V, DT			
C123, C124	392883397	0.33 μ F, 50V, LL			
C125, C126	384121533	15,000pF \pm 2%, 50V, DT			
C127–C130	352741009	10 μ F, 16V, Elect.			
C131, C132	392881097	0.1 μ F, 50V, LL			
C133, C134	392883397	0.33 μ F, 50V, LL			
C135, C136	384121044	0.1 μ F \pm 5%, 50V, DT			
C209, C210	392850477	4.7 μ F, 25V, LL			
C213, C214	352741009	10 μ F, 16V, Elect.			
C215, C216	384124723	4.700pF \pm 2%, 50V, DT			
C217, C218	392883397	0.33 μ F, 50V, LL			
C219–C222	384121533	15,000pF \pm 3%, 50V, DT			
C223, C224	352741009	10 μ F, 16V, Elect.			
C225, C226	352741009	10 μ F, 16V, Elect.			
C227, C228	392881097	0.1 μ F, 50V, LL			
C229, C230	392883397	0.33 μ F, 50V, LL			
C231, C232	384121044	0.1 μ F \pm 2%, 50V, DT			
C233, C234	352780229	2.2 μ F, 50V, Elect.			
				Screws	
				831130082	3STW+8BQ, Tapping
				82113006	3P+6FN, Pan head
				Plates	
				27300130	Ground
				28175032	Insulator

**LINE AMPLIFIER AND METER DRIVE CIRCUIT
PC BOARD (NAAF-940) -- PARTS LIST**

CIRCUIT NO.	PARTS NO.	DESCRIPTION
	IC	
Q305, Q307	222465	NJM-4558D
	Transistors	
Q331-Q334	2211255	2SC1815(GR)
Q335	2210274	2SK30A(Y), F.E.T
Q584	2211255	2SC1815(GR)
	Diodes	
D331-D336	223105 or	1S1555 or
D582	223133	DS-442X
D581	224059 or	05Z13U or (Only G model)
	224114	GZA13U
	Capacitors	
C315, C316	352741009	10 μ F, 16V, Elect.
C331, C332	352741009	10 μ F, 16V, Elect.
C333, C334	352721019	100 μ F, 6.3V, Elect.
C335	352741019	100 μ F, 16V, Elect.
C581	352733309	33 μ F, 10V, Elect.
	Resistors	
R319, R320	5148053	N16RGL10KB15, Output level variable
R340, R342	5215011	N08HR20KBA, Semi-fixed
R341	5215010	N08HR10KBA, Semi-fixed
	Coil	
L331	233188	NCH-1033
	Switches	
S303, S304	25035219	NPS-142-123-LS183, Tape monitor/Rec. mute push

**MICROPHONE AMPLIFIER PC BOARD
(NAAF-941) -- PARTS LIST**

CIRCUIT NO.	PARTS NO.	DESCRIPTION
	IC	
Q302	222502	NJM-4558DX
	Capacitors	
C205, C206	392883397	0.33 μ F, 50V, LL
C207, C208	352780109	1 μ F, 50V, Elect.
C952, C953	352741009	10 μ F, 16V, Elect.
	Jack	
P303	25045078	HLJ0296-01-010, Microphone

METER PC BOARD (NAMTR-942) -- PARTS LIST

CIRCUIT NO.	PARTS NO.	DESCRIPTION
	243113	NIND-0850S133, Output meter

**TAPE INDICATOR PC BOARD
(NAPL-943) -- PARTS LIST**

CIRCUIT NO.	PARTS NO.	DESCRIPTION
	L.E.Ds	
PL706-PL708	225060	SEL1301E, Green, High, Metal & Normal
PL709	225059	SEL1110S, Red, Dolby HX
	Lead wire	
	79129	JL5-250-5-5-P2.5
	Holder	
	27190086	

**METER ILLUMINATION LAMP PC BOARD
(NAPL-949) -- PARTS LIST**

210090	PL14V150mA, Lamp
--------	------------------

**TIMER/MEMORY SWITCH PC BOARD
(NASW-945) -- PARTS LIST**

CIRCUIT NO.	PARTS NO.	DESCRIPTION
D711, D712	223133 or	DS-442X or
	223105	1S1555, Diode
S707	25030171	NRS-225-20SBU, Rotary switch

**REMOTE TERMINAL PC BOARD
(NARM-946) -- PARTS LIST**

25050070	NSCT-7P20, DIN socket
79128	JL6-240-5-5-P2.5, Lead wire

**OPERATION KEY PC BOARD
(NASW-947) -- PARTS LIST**

CIRCUIT NO.	PARTS NO.	DESCRIPTION
PL701-PL703	2250261	SEL-303G(C), L.E.D, Green
PL704, PL705	2250101	SEL-103R(C), L.E.D. Red
S701- S706	25035089	NPS-111-S54, Push switch
	25050071	NSAS-12P038, Socket
	27190085	Holder (L)

COMPONENT LOCATION

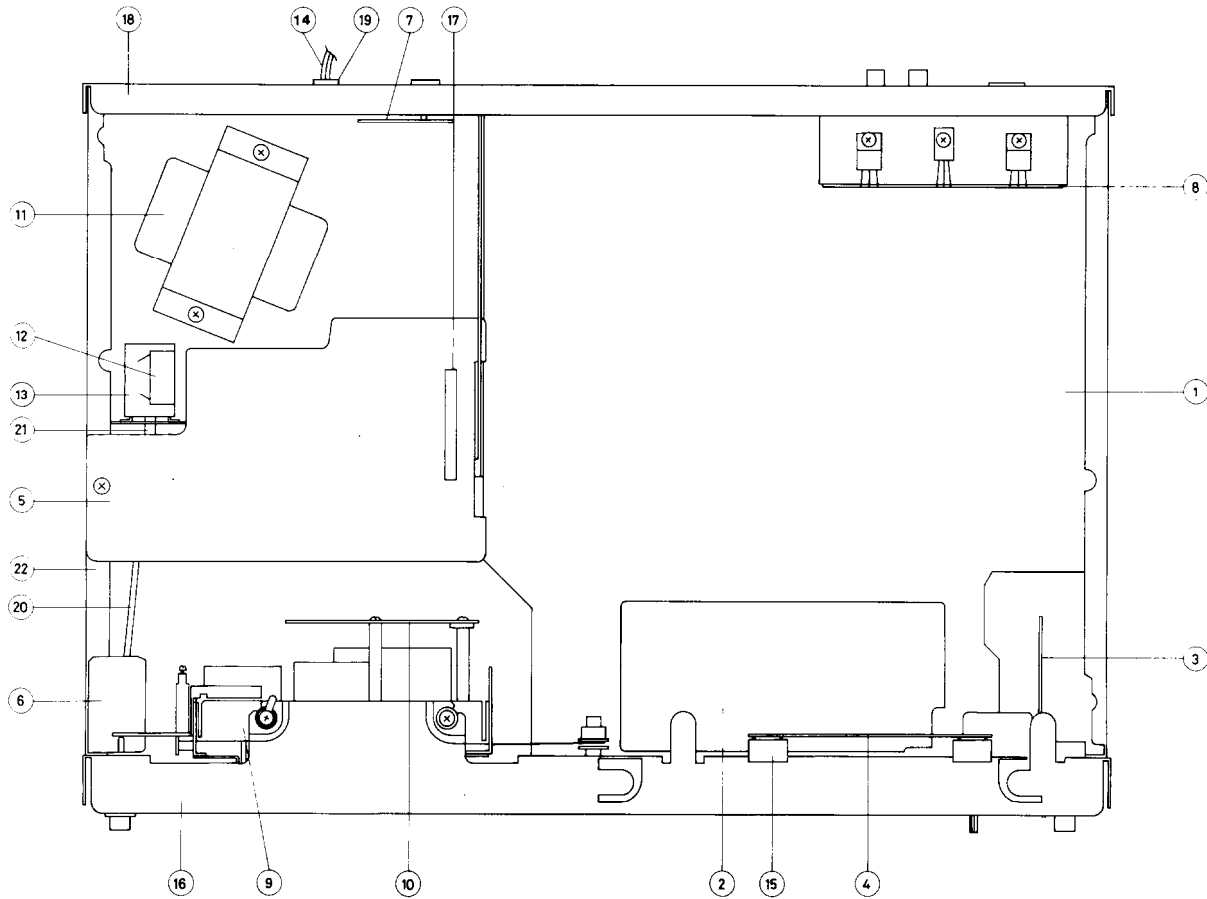

COMPONENT LOCATION – PARTS LIST

120V model

REF. NO.	CIRCUIT NO.	PARTS NO.	DESCRIPTION
1	U1	16299539	NAAF-939, Rec. and playback amplifier p.c.b.
2	U2	16299540B	NAAF-940b, Line amplifier and meter drive circuit p.c.b.
3	U3	16299541	NAAF-941, Microphone amplifier p.c.b.
4	U4	16299542	NAMTR-942, Meter p.c.b.
5	U6	16299544	NACOC-944, Control p.c.b.
6	U7	16299545	NASW-945, Timer/memory p.c.b.
7	U8	16299546	NARM-946, Remote control p.c.b.
8	U10	16299548	NAPS-948, Power supply p.c.b.
9	Z001	244018	NDM-13, Deck mechanism ass'y $\frac{1}{2} \times \frac{1}{2} =$
10		24606106	Motor and back tension circuit p.c.b.
11	T901	230437	NPT-717D, Power transformer
12	C901	3500057	UL125V, 103M, Capacitor
13		25035224	NPS-121-L188P, Power switch
14		253099A	AS-UC-3, Power supply cord
15		243133	NIND-0850S133, VU meter
16		27110116A	Bracket, front
17		25050069	NSAS-12P037, Socket, 12P
18		27120259	Back panel
19		270025	SR-3P-4, Strainrelief
20		27260040	Shaft, switch
21		28320135	Push knob
22		27115073	Side bracket

220V model

REF. NO.	CIRCUIT NO.	PARTS NO.	DESCRIPTION
1	U1	16302539A	NAAF-939a, Rec. and playback amplifier p.c.b.
2	U2	16302540	NAAF-940, Line amplifier and meter drive circuit p.c.b.
3	U3	16299541	NAAF-941, Microphone amplifier p.c.b.
4	U4	16299542	NAMTR-942, Meter p.c.b.
5	U6	16299544	NACOC-944, Control p.c.b.
6	U7	16299545	NASW-945, Timer/memory p.c.b.
7	U8	16299546	NARM-946, Remote control p.c.b.
8	U10	16299548	NAPS-948, Power supply p.c.b.
9	Z001	244018	NDM-13, Deck mechanism ass'y
10		24606106	Motor and back tension circuit p.c.b.
11	T901	230438	NPT-717G, Power transformer
12	C901	3500058	PME265MB510, 0.01 μ F, Capacitor
13		25035192	NPS-121-L156P, Power switch
14		253083	AS-CEE, Power supply cord
15		243133	NIND-0850S133, VU meter
16		27110116A	Bracket, front
17		25050069	NSAS-12P037, Socket, 12P
18		27120260	Back panel
19		270280	SR-4K-4, Strainrelief
20		27260040	Shaft, switch
21		28320135	Push knob
22		27115073	Side bracket