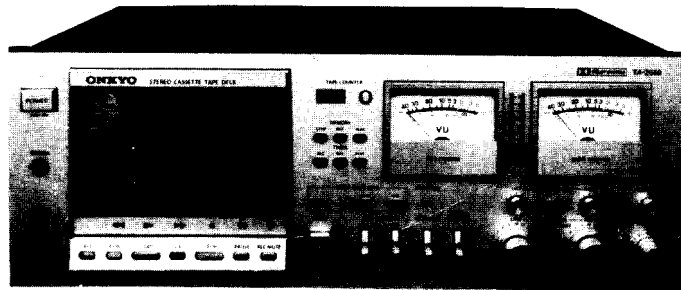

ONKYO. SERVICE MANUAL

STEREO CASSETTE TAPE DECK

Model TA-2080

**TABLE OF CONTENTS**

Item	Page
Specifications	2
Features	2
Mechanism operation	3
Auto accu. bias circuit	4
Control panel circuit description	8
Voltage conversion	10
Component location	11
Exploded view	12
Electrical adjustment procedures	14
Mechanism exploded view	17
Block diagram	19
Connection diagram	21
Mechanism operation-schematic diagram	22
Mechanism operation p.c.b. view	23
Auto accu. bias-schematic diagram	25
Auto accu. bias p.c.b. view	27
Rec./pb. ampli.-schematic diagram	29
Rec./pb. ampli. p.c.b. view	31
Rec./pb. ampli. p.c.b.-parts list	33
Packing procedures	34

ONKYO.
AUDIO COMPONENTS

1. SPECIFICATIONS

Track Format:	4 track, 2 channels
Erase System:	AC erase
Tape Speed:	4.8 cm/sec
Wow & Flutter:	0.045% (WRMS)
Fast Forward and Rewind Time:	90 sec (C-60)
Frequency Response:	20 ~ 20,000 Hz Metal 20 ~ 18,000 Hz High 20 ~ 16,000 Hz Normal
Signal-to-Noise Ratio:	62 dB (Metal tape: Dolby NR OUT) \downarrow $3\frac{1}{2}$ THD
Distortion:	2.0% (0 VU at 1 kHz)
Transistors:	119
PUT	1
IC	15
Diodes:	48
LED:	2
Input Terminals:	Microphone jacks: 2 Minimum input level 0.3 mV/600 Ω Input impedance 5 k Ω Optimum load impedance 200 Ω ~ 50 k Ω Line in jacks: 2 Minimum input level 50 mV Input impedance 100 k Ω

Current consumption (motor)

Playback:	70 - 100 mA
Recording:	70 - 100 mA
Fast forward:	90 - 130 mA
Rewind:	90 - 130 mA
Auto-Stop	
Playback-Stop:	110 - 140 mA
F.F.-Stop:	230 - 280 mA

2. FEATURES

Fully Automatic Accu-Bias Control

In order to ensure that the frequency response of each cassette tape is as flat as possible, it is necessary to adjust the recording bias for each tape accurately.

Onkyo's unique Auto Accu-Bias control in the TA-2080 performs this important task completely automatically.

So no matter what kind of tape is employed, the TA-2080 will automatically adjust for optimum recording quickly and accurately.

3-Head Deck with High Quality Sendust Heads-Superb Performance with the New Metal Tapes

The TA-2080 features separate recording and playback heads incorporated in a single compact head case.

Each head has been designed and developed to achieve new heights of hi-fi performance in the critical electromagnetic transduction process. The use of Sendust, an extremely robust alloy (of very high retentivity) in the core of each head permits full advantage to be taken of high performance metal tapes, resulting in an expanded upper dynamic range and further reduction in distortion. Furthermore, the 3-head arrangement allows direct monitoring of just recorded programs.

Output jacks:	Line out jacks: 2 Standard output level 0.775 V (0 VU) Optimum load impedance over 50 k Ω Headphones 8 Ω ~ 200 Ω
Motors:	2 Motor system PLL DC Servo-motor (CAPSTAN) DC motor (REEL)
Power Supply:	AC 110/120/220/240V 50/60 Hz, AC 240V 50 Hz or AC 120V 60 Hz
Power Consumption:	45W
Dimensions:	438(W) x 160(H) x 365(D) mm 17-1/4" x 6-5/16" x 14-3/8"
Weight:	10.2 kg (22.5 lbs)
Accessories:	Pin-Pin type connecting cords: 2

* Specifications and external appearance are subject to change without prior notice because of product improvements.

Mechanism specifications

- 1) Tape speed: 4.8 cm/sec. (3kHz +3Hz, -1.5Hz)
Use a standard test tape, VTT-658 (3kHz) or equipment.
- 2) Wow and Flutter: Less than 0.045% (WRMS)
- 3) Take-up torque: 35 - 60 gr-cm
- 4) F.F. torque; 70 - 160 gr-cm
- 5) Rewind torque: 70 - 160 gr-cm
- 6) Rewind time: Less than 80 sec. (use a C-60 cassette tape)
- 7) Automatic shut-off time: Less than 5 sec.
- 8) Timer start time: 1 sec. - 3 sec.

Special Laminated Core Erase Head

The special laminated structure of the erase head core is more than sufficient to completely erase the newer metal tapes where the coercivity is more than double that of most other tapes.

Feather-touch Controls Plus Electronic Logic

Besides streamlining tape deck operations with efficient and easy to use feather-touch push-button controls, the TA-2080 is also equipped with electronic logic circuits to protect both tapes and motor from undue strain.

This is accomplished by the incorporation of special circuits connected the STOP position which momentarily stop the tape whenever a switch to another transport mode is made.

Built-in Dolby NR System with Switchable MPX Filter and Separate Dolby Recording Calibration Controls

The built-in Dolby NR system reduces characteristic tape hiss by a very significant margin without affecting the quality of sound. A special feature of this Dolby circuit is the highly reliable single-chip 2-channel monolithic IC (one channel being used for encoding and the other for decoding) which ensures greater stability during Dolby recording

and playback operations. Recording performance is also improved by the Dolby recording calibration controls used to ensure optimum recording settings with different types of tapes. Furthermore, a built-in MPX filter removes the pilot signal when recording FM broadcasts to prevent beat interference.

High Grade Level Meters with Left/Right 10-Point LED Peak Indicator Lamps

With high grade logarithmic compressed wide range level meters plus independent left/right high precision 10-point LED peak indicator lamps, recording level settings are made easier and more accurate. Even program sources of very

wide dynamic range will be recorded true-to-the-original with practically negligible distortion.

You are now the owner of a very high quality stereo cassette tape deck. To ensure many long years of listening enjoyment free of trouble, read this manual carefully and familiarize yourself with all facets of operation. Failure to do so may result in loss of performance, and also in possible malfunction.

3. MECHANISM OPERATION

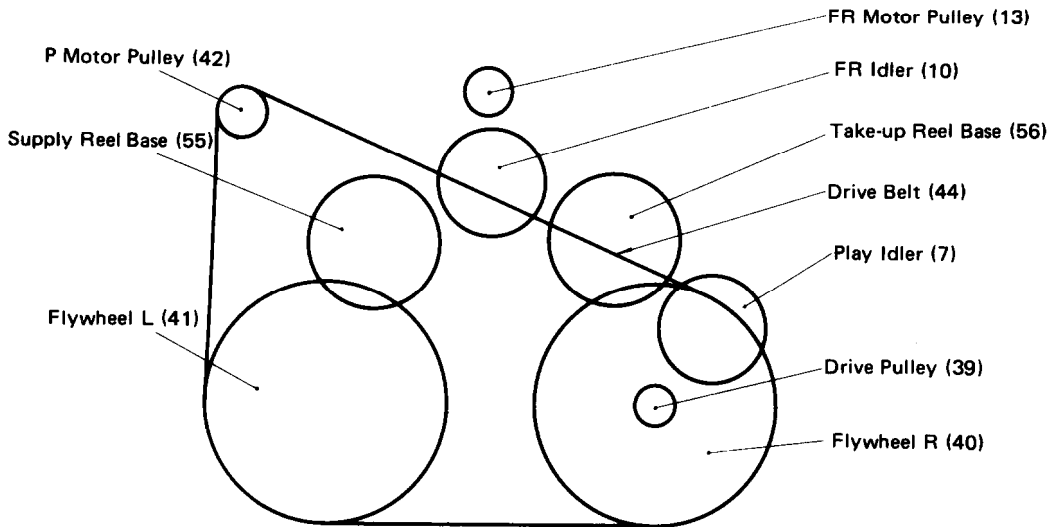

Note: the figure following each part name is the part number as shown in the exploded view.

Fig. 1 Mechanism operation diagram

1. Play Mode

At the start of play mode, solenoid C (105) is activated, resulting in the sub-chassis assembly (17) being thrust upwards, and the play idler (7) being pressed against the drive pulley (39) and take-up reel base (56) by the P-coupled lever (49), thereby driving the take-up reel. Play torque is adjusted by the amount of friction applied to the piece of felt located in the center of the take-up reel.

2. Fast Forward Mode

When the FF key is pressed, solenoid B (106) is activated and the FR idler (10) is pressed against the FR motor pulley (13) and take-up reel base (56) by plunger lever B (15) to commence fast forward mode. FF

torque is adjusted by the amount of friction applied to the piece of felt located in the FR idler.

3. Rewind Mode

Operation during rewind mode is much the same as during fast forward, the main difference being that the FR motor is made to rotate in the opposite direction by having its polarity inverted. And since the motor rotates in the opposite direction, the FR motor pulley (13) is pressed against the supply reel base (55).

4. AUTO ACCU-BIAS CIRCUIT

As a result of the developments in cassette tapes over the last decade, a very wide range of different tapes has become available on the market. And since there are significant differences in the bias characteristics between different tapes, there will be differences in frequency response when these tapes are played in the same cassette tape deck. In order to compensate these differences and obtain a flat frequency response, many decks have been equipped with bias adjustment controls which permit the user to adjust the bias current to a level suitable for the tape being used (decreasing the bias in tape A and increasing the bias in tape B in fig. 2 permits a flat frequency response to be obtained as shown by the dotted line). The purpose of the Auto Accu-Bias circuit, however, is to perform this adjustment by a completely automatic system.

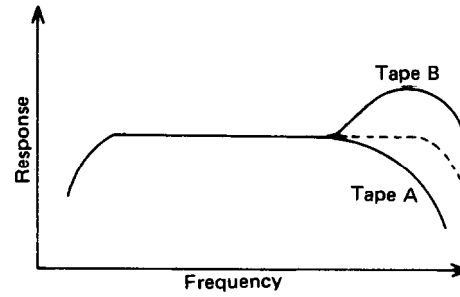

Fig. 2

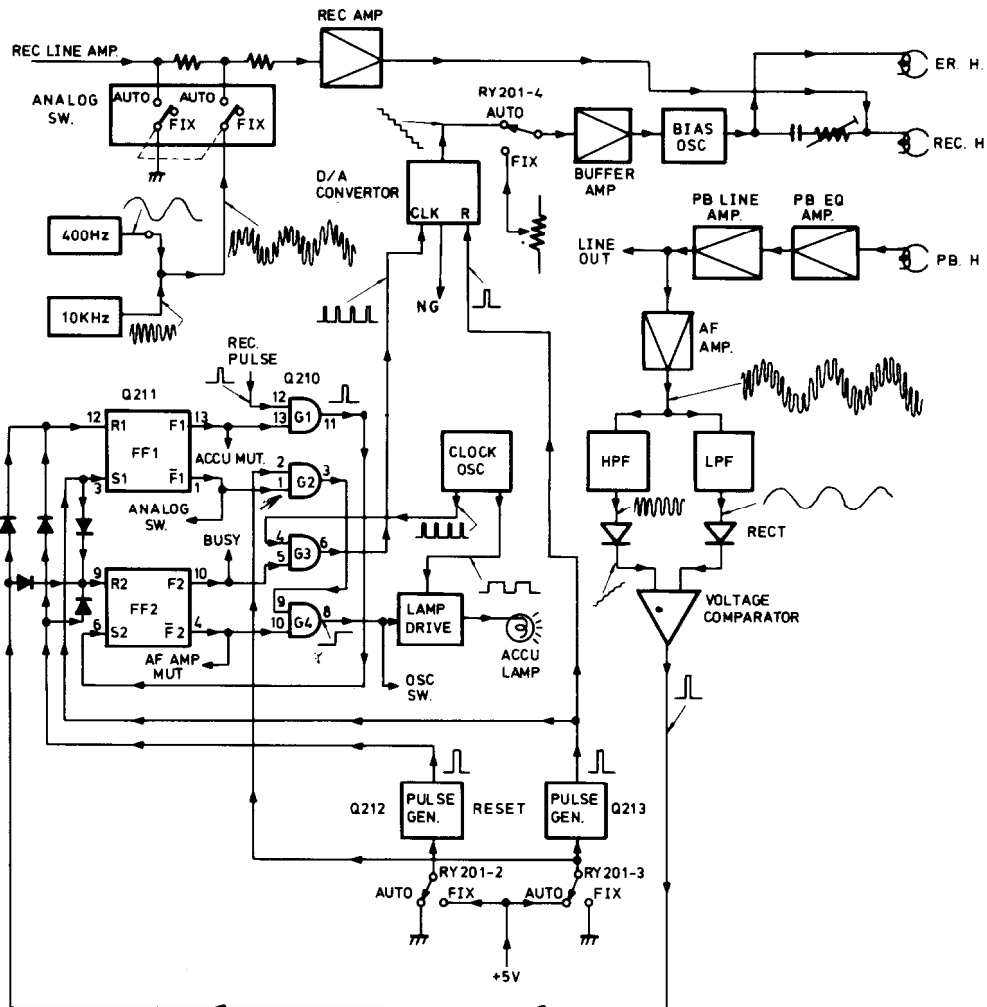

Fig. 3 Auto-accu bias circuit block diagram

1. Operational Principles

See Fig. 3 for the block diagram of the Auto Accu-Bias circuit. Optimum bias for the tape is adjusted automatically in the following way.

When the bias current is varied stepwise from 'large' to 'small' through 16 steps, and 400Hz and 10kHz signals of equal level are mixed and recorded on the tape, and then monitored immediately, the level of the mid-range signal shows very little change as the bias current is varied (see fig. 4). The level of the high frequency signal, however, changes considerably across the same variation range.

By passing the playback signal through high-pass and low-pass filters to separate the signal into the 400Hz and 10kHz signals, and then rectifying each signal, DC voltages in proportion to the signal levels may be obtained (see fig. 4). These 2 DC voltages are then compared by a voltage comparator, and when the levels of the 2 signals (400Hz and 10kHz) are equal the comparator output will switch from low to high level, thereby producing a pulse which is used to halt the stepwise variations in bias current.

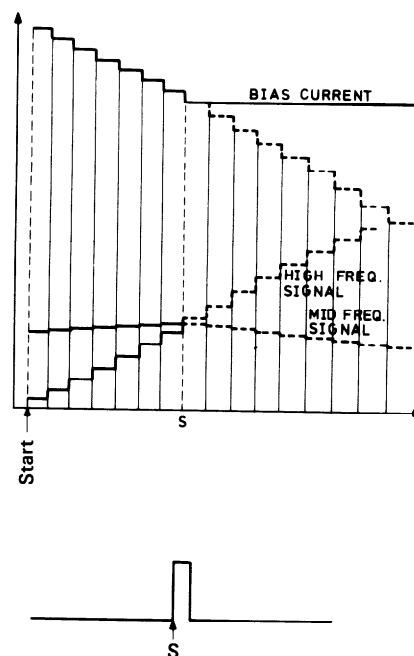

Fig. 4

2. Major Circuits

(1) Audio amplifier (Q202 and Q238)

This amplifier stage amplifies the playback mixed signal to about 1V. L201 serves as a bias trap coil, while Q201 prevents misoperation due to transient outputs when starting to record the mixed signal (and is muted when not in auto accu-bias adjustment mode).

(2) Voltage comparator

This stage compares the voltages applied to terminal nos. 2 and 3 of Q205. When the input voltage applied to terminal no. 3 is lower than that applied to terminal no. 2, output terminal no. 6 is switched to low level, while if the voltage is higher, or equal, the output is switched to high level. Furthermore, when there is no AF amplifier output, a 50mV signal is applied via R517 to terminal no. 2 to switch the output terminal to low level.

(3) Analog switch

Q208 and Q209 operate as the AF signal selector switch used to switch either the mixed signal required for auto accu-bias adjustment, or the normal recording signal, to the input terminal of the recording amplifier.

(4) Oscillator switch

This circuit serves to switch the power supply on and off for the 400Hz and 10kHz oscillators. Q222 is the actual switching stage, while Q221 and Q220 serve as the control drive circuit. Q222 is turned on only during the automatic bias adjustment.

(5) Clock stage

This circuit generates the clock pulses to be applied to Q233 of the D/A converter employed to vary the bias current in precise steps. Q224 and Q225 form an astable multi-vibrator which generates clock

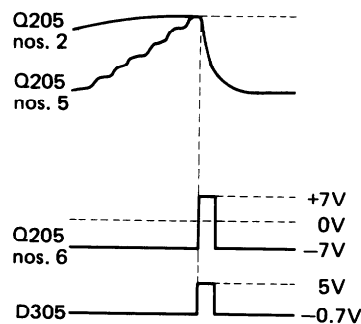

Fig. 5

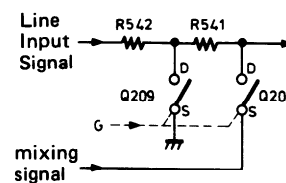

Fig. 6

pulse signals passed via the Q226 buffer amplifier. The Q224 output is used to light up the ACCU BIAS indicator lamp.

(6) AND gates

Q210 contains 4 AND gates used in the control of supply of clock pulses to Q233 in the D/A converter, the ACCU lamp, and Q211 in the R-S flip-flop stage.

(7) R-S flip-flop stage

Q211 contains 4 NOR gates combined to form 2 pairs of R-S flip-flops. These 2 flip-flops are set to AUTO and FIXED mode, and are used to maintain the adjusted condition after completion of the automatic bias adjustment.

(8) D/A converter

This D/A converter is formed by Q233, R564 ~ R568, and Q234. Q233 is a 4-bit binary counter designed to count the number of clock pulses applied to terminal no. 14. The result of the counting operations is always presented at output terminals nos. 8, 9, 10, and 11 in binary code form. When this binary code is compounded by R564 ~

R568, a current is obtained which varies in stepwise fashion in response to changes in the binary code. This current is then converted into a stepwise varied voltage by Q234.

(9) Level shift stage

This circuit converts the output voltage (0 ~ 5V) of Q210 in the AND gates stage into the input voltage (7 ~ 12 V) for Q233 in the D/A converter. Level shift for the reset pulse signal is performed by Q229 and Q230, while level shift for the clock pulse signals is performed by Q231 and Q232.

(10) Reset stage

For AUTO/FIXED mode switching, pulse signals are generated by Q212 and Q213 and used in the initialization of the Q233 binary counter and the 2 pairs of R-S flip-flops. Q212 is activated to switch from AUTO to FIXED mode, while Q213 is activated to switch from FIXED to AUTO mode.

3. Overall Operation

(1) AUTO MODE Setting

When the AUTO position (S201) of the AUTO/FIXED mode selector is set, Q215 is turned on by the voltage on the B4 terminal, resulting in a current flowing from the 12V line to ground via the coil of relay RY201, S201, Q215, and S202. The RY201 relay is thus activated, closing contact RY201-1 for the relay to be self held via the Q217, S202 to ground route. Consequently, contacts RY201-2 and RY201-3 of the reset stage relay are switched over to the AUTO position, resulting in a single pulse being generated by Q213. Power is also supplied to the clock stage via contact RY201-3 to commence the blinking on/off action of the ACCU-BIAS indicator lamp.

(2) Initialization

The Q213 output pulse sets the FF1 R-S flip-flop while resetting FF2 via D308. Outputs F1 and F2 are switched to high level (H) while F1 and F2 are switched to low level (L), thereby enabling pulse signals to be passed through gate G1. The G3 gate, on the other hand, is closed to pulse signals.

At the same time, a level shifted pulse is applied from Q213 to the reset terminal (2) of the Q233 binary counter which is thereby initialized (reset to no count status) to provide maximum bias level. Line out is muted by F1 (ACCU MUT).⁽⁴⁾

(3) Start of Automatic Bias Adjustment

When recording is then started, an output start pulse (REC PLS) is generated by the tape transport stage (NACOC-662) and passed through gate G1 to set flip-flop FF2, resulting in F2 being set to H, and $\bar{F}2$ to L. Consequently, a clock pulse is passed through gate G3, level shifted, and then applied to the Q233 binary counter, and a stepwise varying voltage synchronized with the clock pulse signals by the D/A converter appears at the Q235 output. Since this output voltage is the bias oscillator power

supply voltage, the bias will also be varied in stepwise fashion while being recorded. The FF1 flip-flop, on the other hand, remains in the initialized state, which means $\bar{F}1$ will be L, and the G2 gate output also L. So no matter what the $\bar{F}2$ output may be, the G4 gate output will be L, which means that the OSC SW Q220 will be off and Q222 on, and the 400Hz and 10 kHz oscillators will be operating with the mixed signal output applied to the analog switch. Furthermore, since the analog switch Q223, Q208, and Q209 will be on while $\bar{F}1$ is at L, the mixed signal will be passed via Q208 to the recording amplifier (see fig. 6), and be subsequently recorded on the tape while the bias is being stepped down in successive steps.

(4) Flat Frequency Response Detection and Bias Setting

Since the G4 gate output has been set to L the AF amplifier is no longer muted by Q201, resulting in the playback mixed signal being amplified immediately (by this AF amplifier) and passed through low-pass and high-pass filters to recover the original 400Hz and 10kHz signals. Each signal is then rectified into a DC voltage, and applied to terminals 2 and 3 of Q205 of the voltage comparator. These 2 voltages are in proportion to the respective levels of the 400Hz and 10kHz playback signals. Terminal 3 voltage varies in the same manner (see fig. 5) as the bias (i.e. in successive steps), but terminal 2 voltage remains more or less the same, so at a certain point both voltages will become equal to each other. At that moment, the output of the Q205 voltage comparator will be switched from L to H, and FF1 and FF2 be reset via D306 and D307. Consequently, F1 and F2 will be switched to L and $\bar{F}1$ and $\bar{F}2$ switched to H, resulting in the G4 gate output also being switched to H. The clock oscillator output which had been switched on and off repeatedly until that moment will remain on to subsequently light up the ACCU-BIAS lamp continuously. And since F2 has been switched to L, the G3 gate will block the clock pulses, and the Q233 binary counter of the D/A converter will stop counting. Note, however, that the counter output will hold the final count result in binary code form, and maintain that status until reset. This means that the D/A converter output voltage will be maintained at the value corresponding to the final count of the binary counter, and that the bias, too, will also be held at the level reached at that time. And since F1 is at L, the G1 gate will block the start pulses (REC PLS), thereby preventing the recording start start-pulses from setting FF2 from that point onwards. This means that the automatic adjustment process will not be repeated when normal recording and playback modes are used after the initial adjustment. And with F2 at H, the AF amplifier muting Q201 will be turned on to mute the playback signal.

(5) Recording Auto-Stop and Return to Line Input

The recording mode is released automatically once the automatic bias adjustment has been completed. And if the memory rewind has been already set, the tape will automatically rewind to the start of the tape and then stop. This series of operations is controlled by F2 in FF2. F2 is set to H at the start of the auto accu-bias adjustment, and then switched to L upon completion. The "drop" stroke involved in the switching from H to L is detected (a pulse signal is applied to terminal 10 of Q701 by C710 in the NACOC-662 tape transport stage) and the tape transport is stopped. Furthermore, since F1 will be L when FF1 is set to AUTO mode, and then switched to H upon completion of the automatic bias adjustment, the analog switch will be on during that interval, and off during all other times. In other words, the analog switch is turned off at the end of the bias adjustment, thereby permitting the normal line input signal (see fig. 6) to be recorded at the optimum bias level which has just been set automatically. And since the G4 gate output is switched to H, Q222 in the oscillator switch is turned off to inhibit the generation of the 400 Hz and 10kHz signals. The switching of F1 to L also cancels the LINE OUT muting (ACCU MUT).

(6) Release of AUTO Mode

To switch the automatically adjusted bias back to fixed bias, or to switch AUTO mode to FIXED mode (noting that once the automatic adjustment process has been commenced, mode switching will not be possible until the process has been completed) press the FIX switch (S-202). Relay RY201 will thereby be released, resulting in the RY201-1 switch (formed from the contact of the RY201 relay) being turned off to release the self held relay. The RY201-2 and RY201-3 switches (which are also formed from the relay contacts) are switched to the FIXED position (see Reset stage), resulting in a single output pulse from Q212 which is passed via D309 and D310 to reset FF1 and FF2. F1 and F2 are consequently set to L, the G1 gate cuts off the start pulse, and the G3 gate cuts off the clock pulse, thereby preventing any further automatic bias adjustment. And since F1 is switched to H, the analog switch is turned off to enable line inputs to be received. Furthermore, when RY201-3 (contact for the reset stage relay) is switched to the FIXED position, the +5V power supply for the clocked stage, lamp driver, and oscillator switch is interrupted, thereby inhibiting the generation of clock pulses, and the 400Hz and 10kHz signals. The terminal 2 input of the G2 gate is switched to L, resulting in the G4 gate output also being switched to L, thereby turning the ACCU-BIAS lamp off.

(7) Mode when Power Switched On

When the tape deck power switch is turned on, the RY201 relay driver circuit will be "open", so RY201-1 and S201 will be in the FIXED position.

(8) Miscellaneous

(a) Busy signal

The tape deck has been designed to prevent misoperation while the automatic bias adjustment operation is in progress. For this reason, the tape transport function keys (REC, PLAY, STOP, etc.) will have no effect until the adjustment has been completed. When the "drop" stroke of the BUSY signal (which had been at H) is detected, tape transport is stopped at the completion of the bias adjustment operation (as was described above in section 5/).

(b) NG signal

If the frequency response fails to reach "flat" status after the bias has been progressively varied in 16 steps during the automatic bias adjustment procedure, the NG signal is employed to switch the mode over automatically to FIXED. Terminal 11 of the D/A converter Q233 is switched from H to L (as the 17th step). This drop stroke is detected by Q218 (relay driver circuit), resulting in Q217 being turned off, and the RY201 relay being released (as was described above in section 6/) to switch over to FIXED mode. And since the BUSY signal is switched to L, tape transport will also be stopped.

(c) When AUTO mode setting key is pressed during playback in FIXED mode

If the AUTO mode key is pressed during playback in FIXED mode, the AUTO mode will be set up as described in section 1) above, and the ACCU-BIAS lamp will commence to blink on and off. However, since there will be no input start pulse signals unless the recording mode is commenced, there will be no automatic bias adjustment. The lamp will simply continue to blink on and off while proceeding in the previous playback mode.

(d) When the FIXED mode key is pressed during automatic bias adjustment

As has already been described in section (6) switch over to FIXED mode is not possible while the automatic bias adjustment is in progress. Since the REC SIG of the NACOC-662 tape transport stage is H, the Q216 relay driver circuit will be on, thereby short circuiting the S202 FIXED mode switch.

(e) When the AUTO mode setting key is pressed during recording in FIXED mode

In this case, too, it is not possible to set AUTO mode. The ACCU lamp remains off, and the recording continues in FIXED mode. Since REC SIG is H during recordings, Q214 of the relay driver circuit will be on, and Q215 off, thereby making the AUTO mode setting switch S201 inoperative.

5. CONTROL PANEL CIRCUIT DESCRIPTION

1. Power Supply Circuit and Tape Slack Elimination Circuit

When the power is first switched on, a +12V voltage is applied to the B3 line, and passed via R951 to charge up C951. Once the potential on this capacitor reaches 0.4V (approx.) a current will flow through to the base of Q952. The circuit containing Q951 and Q952 will thus become a positive feedback circuit which will subsequently turn on very rapidly. The zener diode connected to the base of Q952 clamps the output voltage applied to the logic circuit to 5V.

If a cassette tape has already been loaded in the cassette compartment, the 5V will be applied via cassette switch B and cassette switch A to the one-shot multiple circuit consisting of Q704 and Q705. Since there will be no charge on C708 at this time, Q705 will turn off and Q704 turn on. This status will be inverted, however, about 0.7 sec. later due to the time constant of the integrating circuit formed by R707, C707, and C708. And during the short period that Q705 remains off, the tape slack elimination operation is performed.

Q706 is turned on when Q705 is turned off, the resultant output being passed via R737 to activate the play solenoid drive circuit (see section 2). The output is also passed via D707 to pin 21 of the IC in parallel with the rewind mode output, thereby resulting in simultaneous operation with rewind mode. Since Q704 is on during this period, pin 14 will be at low level, thereby inhibiting all IC outputs except the muting output by switching the outputs to high impedance. Q702 is also turned off during this period, thereby operating in such a way as to prevent the reception of any input signals from the operation mode switches.

If there is no tape cassette in the compartment when the power is switched on, cassette switch A will remain open to prevent the tape slack elimination operation from proceeding. Once a tape is loaded and cassette switch A is closed, the +5V is applied to the transistor circuit to eliminate tape slack. Note that cassette switch B will close only when the compartment door has been properly closed.

2. Play Mode

When IC input terminal pin 4 is switched to low level, a 5V output voltage appears at pin 15 and is applied to Q723 via R736. Q724 is thus turned on, resulting in +B3 being passed through this transistor and partly applied to the play solenoid, and partly to C718. While this capacitor is being charged, Q725 is also turned on, resulting in the play solenoid also being activated by -B7. So for a brief period, a large current is passed through the solenoid, thereby increasing its attractive force. Once C718 is fully charged, Q725 is turned off, and the current from B3 is passed via D709 to ground.

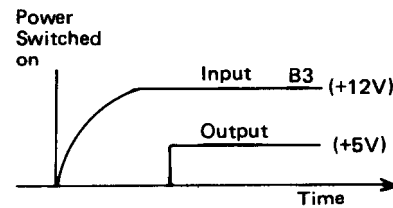

Fig. 7

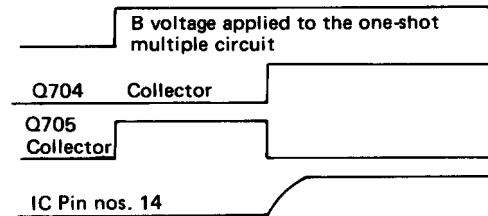

Fig. 8

3. Fast Forward and Rewind Modes

A 5V output voltage appears at pin 21 when input pin 2 is temporarily switched to low level, and at pin 22 when pin 3 is switched to low level. The pin 21 output is applied to Q721 via R729, while the pin 22 output is also applied to Q721 but via R730. This transistor is consequently turned on, and all subsequent operations are exactly the same as for play mode. In other words, the brake solenoid is activated when the input is either a FF or REW input.

If, for example, there is an output on pin 22 in the reel motor drive circuit (shown in the accompanying diagram), Q716 will be turned on, resulting in a flow of current through R727 to turn Q719 on. In other words, the current from B3 is passed via Q719, the motor, and Q716.

If, on the other hand, an output is applied to pin 21, Q717 and Q718 will both be turned on in exactly the same way, resulting in current flowing through the reel motor in the opposite direction to rotate the motor in reverse.

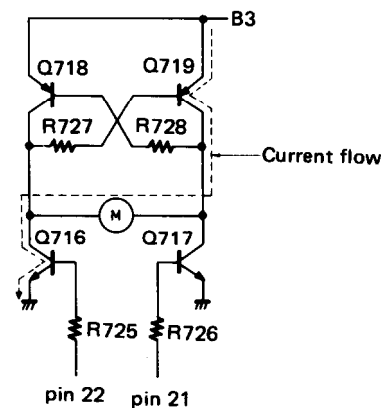

Fig. 9

4. The TC9121P Clock Circuit

This IC incorporates a clock circuit whose cycle period is determined by capacitor and resistor connected in parallel between pin 13 and ground. This clock circuit is employed to determine the period of time that the muting signal is delayed when commencing play mode, and the temporary stop involved when switching directly to play mode from fast forward and rewind modes. Also note that play mode is not commenced immediately when the PLAY key is pressed during stop mode, but is delayed for a short period in the same way as when switching directly from fast forward and rewind modes. Although response to key inputs is delayed, response to the PLAY key input is speeded up by employing a fast clock period determined by C724 and R744 during stop mode. But once the deck is operated in play, fast forward, or rewind modes, the clock period is lengthened to suitable values for muting and the temporary delay involved in direct switching to another mode. This is achieved by applying a 5V output to pin 17 during all modes except stop. This output is passed via the integrating circuiting containing R746 and C720 to turn Q728 on after a certain fixed time, thereby adding C719 in parallel with C724. This consequently lengthens the clock period.

5. REC Pulse Generator Circuit

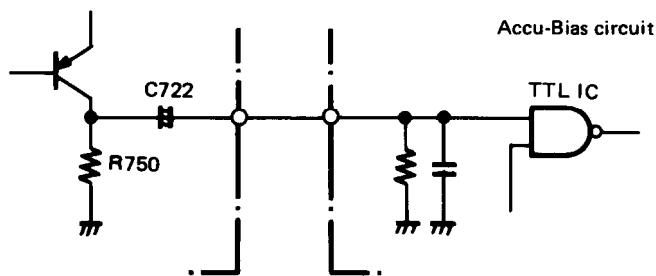

Fig. 10

This circuit generates the command signal required to start the Auto Accu-Bias circuit. When the play solenoid is activated during recording mode, a single pulse output signal is generated after a very short period. During recording mode, the emitter of Q729 is connected to the IC output terminal pin 16 where a 5V output voltage appears, while the base is connected to the collector of Q723 in the play solenoid drive circuit (after being divided by R748 and R747). When Q723 is off, a potential of approximately 5.4V is applied to the base of Q729, thereby applying reverse bias in respect to the emitter (irrespective of whether there is an output on pin 16 or not). Since there will be a 5V output voltage on pin 16 during recording mode, Q723 will be turned on, a base current will flow through Q729, and the output appear at R750. This output is then passed to C722, and the resultant charge current flowing through the Accu-Bias circuit activates the TTL IC.

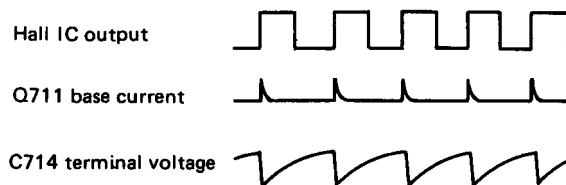

Fig. 11

The 5V output voltage appearing at IC pin 17 during all modes except stop is passed via R719 to charge up C714. However, until the tape end is reached, the take-up reel will continue to rotate, thereby generating on-off pulse signals from the Hall IC. These signals are passed via C715 to Q711, which is turned on, and consequently prevents C714 from being fully charged up (as shown in the accompanying diagram).

However, once the end of the tape is reached, the Hall IC output signals cease and Q711 remains off, permitting C714 to be charged up to the power supply voltage level. Once this voltage exceeds the value set by the voltage divided by R718 and R717 and applied to the gate of Q710, the anode and cathode of Q710 will commence to pass current, resulting in the charge on C714 being passed to the base of Q709 via Q710. The Q709 transistor reduces the IC input pin 12 (Z input) to ground level, thereby constituting a stop signal.

In order to block the auto-stop mechanism during pause mode, Q711 is turned on by IC pin 19 (0-pause) via R720 to prevent charge up of C714.

7. Timer REC/PLAY Circuit

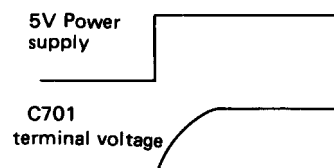
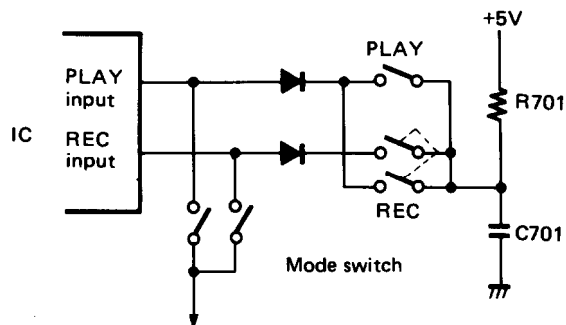

Fig. 12

When the tape deck power supply is turned on, a voltage of rapid rise time is applied to the IC from the 5V power supply, thereby activating the IC. However, when the **TIMER REC** switch is set, and the **PLAY** and **REC** inputs passed via D703 and D704 to C701, there will be no charge on C701 at the instant that the 5V voltage is first applied, making it appear that low level inputs are applied to the **REC** and **PLAY** input terminals to set the IC in **REC** mode.

Note, however, that as was described above under section 1, the IC inhibit terminal pin 14 ($\overline{\text{INH}}$) is switched to low level to inhibit outputs in order to activate the tape slack elimination circuit. The inhibit terminal is then switched to high level to commence recording mode.

8. Memory Stop/Play Circuit

When pin 11 (X input) is switched to low level during rewind mode, tape transport will stop if pin 9 (A-PLAY) is at high level, and commence in play mode if at low level. If the **MEMORY** switch is off during rewind mode, C713 will be charged up by the 5V applied via R715. So even if the counter switch has been turned on, the potential at both terminals of C711 will be equal, thereby preventing pin 11 switching to low level. Tape transport will thus remain in rewind mode. If the **MEMORY** switch has been set to the **PLAY** position, on the other hand, C713 will discharge via R714, and the potential of the point of connection between R714 and R715 will become 0.45V approx. If the counter switch is turned on under these conditions C711 will charge up, and pin 11 (X input) will temporarily be switched to low level. The level of input pin 9 (which determines whether the deck will switch to stop mode or play mode) is switched to low level by R711 (8.2k Ω) connected to pin 9, resulting in the IC producing a **PLAY** output following the **REW** output.

Pin 12 (Z input) may also be set to low level during rewind mode. In order to prevent rewind mode being switched directly to play mode when the auto-stop signal is applied to pin 12 (the only terminal to which it can be applied) prior to the tape counter reaching 999, the base of Q708 is connected to pin 12 via R712. So if pin 12 is switched to low level by the auto-stop

signal during rewind mode, Q708 will be turned on, thereby switching pin 9 to high level to activate stop mode.

When the **MEMORY** switch is set to the **STOP** position, the Q708 base current is passed via D705 and R713 to ground, thereby turning the transistor on and setting pin 9 (**AUTO-PLAY** input) to high level. In all other respects, operation is the same as in memory play mode.

9. Returning Tape to Start After Completing Auto-Accu Bias Adjustment

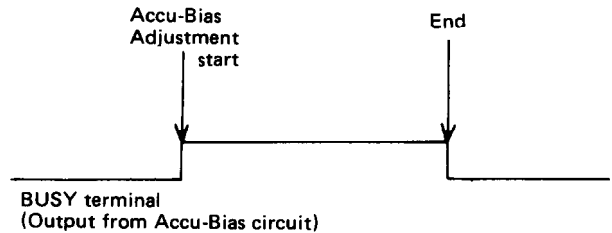

Fig. 13

If pin 10 (Y input) is switched to low level during playback or recording modes, tape transport will stop when pin 8 (**AUTO-REW** input) is high, but switch to rewind mode if the level is low.

At the start of the **Accu-Bias** adjustment, a 5V output signal from the **Accu-Bias** circuit is applied to the **BUSY** terminal, while at the end of the adjustment, the output level drops back to ground level. While this output signal is at high level, Q703 is turned on, and Q702 turned off, thereby preventing the reception of input signals from the operational mode switches. When the **BUSY** terminal signal ceases after completion of the **Accu-Bias** adjustment, C710 is charged up, and pin 10 (Y input) switched instantly to low level. If the **MEMORY** switch is in the **STOP** position at this time, Q707 will be turned on by the charged on C712, thereby switching pin 8 (**AUTO-REW**) to low level to switch the IC to rewind mode. The tape will then come to a stop when the preset counter reaches 999. If, on the other hand, the **MEMORY** switch is set to the **OFF** or **PLAY** positions, Q707 will remain off, and pin 8 remain at high level, resulting in pin 10 being switched immediately to low level to stop the tape at that spot.

6. VOLTAGE CONVERSION (Universal model)

This model is equipped with a universal power transformer to permit operation at either power source of 110, 120, 220 or 240V AC 50/60Hz.

To convert the unit to a different power source voltage, change the plug as illustrated in the drawing below.

CAUTION: DISCONNECT POWER SUPPLY CORD FROM AC OUTLET BEFORE CONVERTING VOLTAGE.

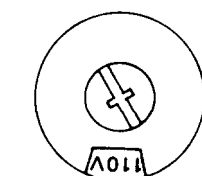
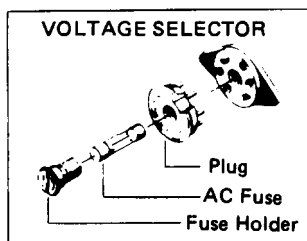

For 110V Operation

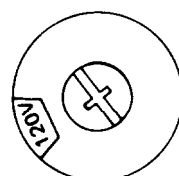

For 120V Operation

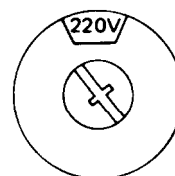

For 220V Operation

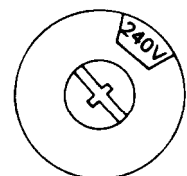

For 240V Operation

7. COMPONENT LOCATION

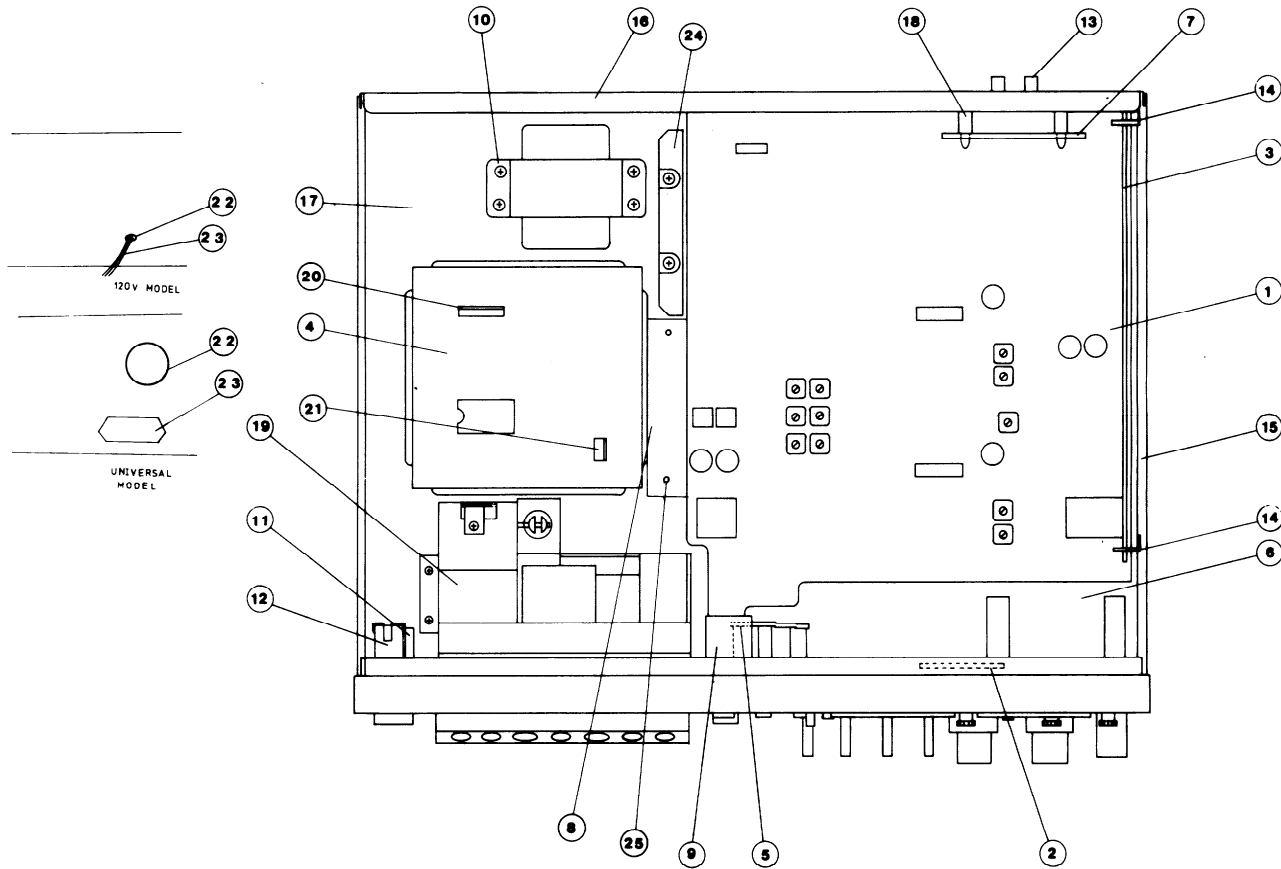

Fig. 14

COMPONENT LOCATION – PARTS LIST

120V model

REF. NO.	CIRCUIT NO.	PARTS NO.	DESCRIPTION
1	U1	16429565	NAAF-665, Rec./pb p.c.b. complete
2	U2	16429563	NADA-563, Meter drive circuit p.c.b. complete
3	U3	16429566	NABC-666, Auto acc. bias circuit p.c.b. complete
4	U4	16429562	NACOC-662, Control p.c.b. complete
5	U6	16429560	NASW-560, Switch p.c.b. complete
6	U8	16429567	NASW-667, Switch p.c.b. complete
7	U9	16429501	NABM-701, Buffer/Memory circuit p.c.b. complete
8	U10	16429507	NAAB-707, Muting circuit p.c.b. complete
9		24606091	Hall IC p.c.b.
10	T901	230299-2	NPT-673D, Power transformer
11	C952	3504012	UL125V103M, UL capacitor
12	S901	25035061A	NPS-121-L26P, Power switch
13		25045025	NPJ-4PRBL03, Input/output terminal
14		27130154	Bracket for p.c.b.
15	A002	27115038A	Side bracket
16	A029	27120135-1	Back panel
17	A003	27100034	Chassis
18	A034	27190040	TCBS-10N, Holder
19	Z001	244009-1	NDM-04, Deck mechanism complete
20	P701	2000133	NSAS-5P010, Socket
21	P702	2000134	NSAS-10P011, Socket
22	A036	270025	SR-3P4, Strainrelief
23		253099	AS-UC3, Power supply cord
24	A017	27160046A	Radiator
25	A026	27190038	Holder

Universal model

REF. NO.	CIRCUIT NO.	PARTS NO.	DESCRIPTION
1	U1	16429565	NAAF-665, Rec./pb p.c.b. complete
2	U2	16429563	NADA-563, Meter drive circuit p.c.b. complete
3	U3	16429566	NABC-666, Auto acc. bias circuit p.c.b. complete
4	U4	16429562	NACOC-662, Control p.c.b. complete
5	U6	16429560	NASW-560, Switch p.c.b. complete
6	U8	16429567	NASW-667, Switch p.c.b. complete
7	U9	16429501	NABM-701, Buffer/Memory circuit p.c.b. complete
8	U10	16429507	NAAB-707, Muting circuit p.c.b. complete
9			Hall IC p.c.b.
10	T901	230300-2	NPT-673ADGQ, Power transformer
11	C952, C953	3500052	PME271Y510CEE, IS capacitor
12	S901	25035051	NPS-121-L16P, Power switch
13		25045025	NPJ-4PRBL03, Input/output terminal
14		27130154	Bracket for p.c.b.
15	A002	27115038A	Side bracket
16	A029	27120144	Back panel
17	A003	27100034	Chassis
18	A034	27190040	TCBS-10N, Holder
19	Z001	244009-1	NDM-04, Deck mechanism complete
20	P701	2000133	NSAS-5P010, Socket
21	P702	2000134	NSAS-10P011, Socket
22		25050021	X-17240, VS Socket
		252002	2A-T, Fuse
		25050018	PA-125, 3P Inlet
24	A017	27160046A	Radiator
25	A026	27190038	Holder

8. EXPLODED VIEW

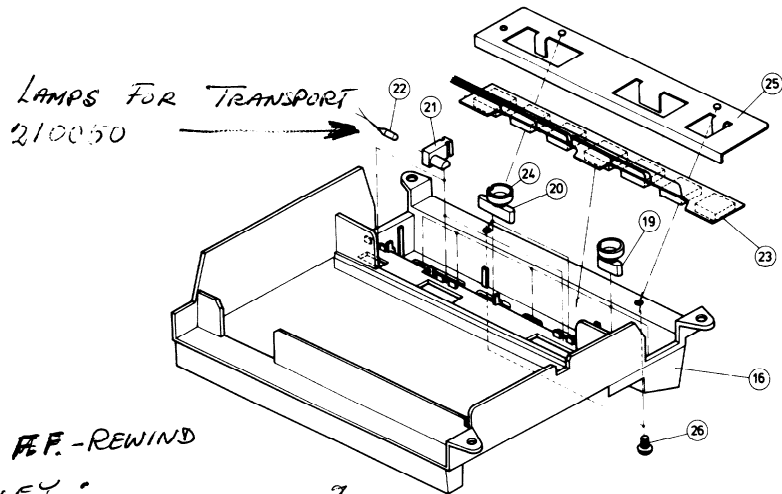

Fig. 15

To CHANGE F.F.-REWIND MOTOR-PULLEY :

- 1. TAKE OUT OPERATING FRAME ASSY (4 SCREWS) (OUT FIRST TAKE OUT FRONT PANEL)
- 2. TAKE OUT CASSETTE PANEL & CASE (4 SMALL SCREWS); DISASSEMBLY A SPRING AND BELT PLUS ONE SMALL LEVER
- 3. TAKE OUT MOTOR (2 SCREWS)
- 4. CHANGE MOTOR OR PULLEY

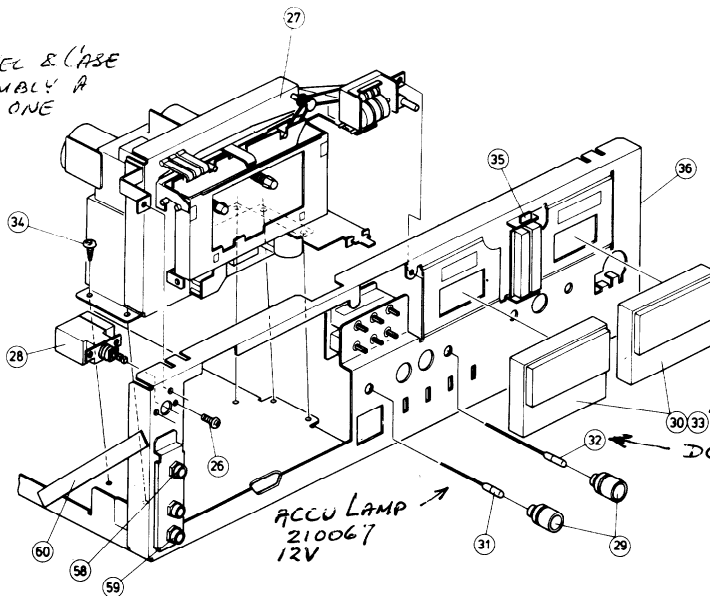

Fig. 16

LAMP IN TRANSPORT
210053
6V - 0.05A

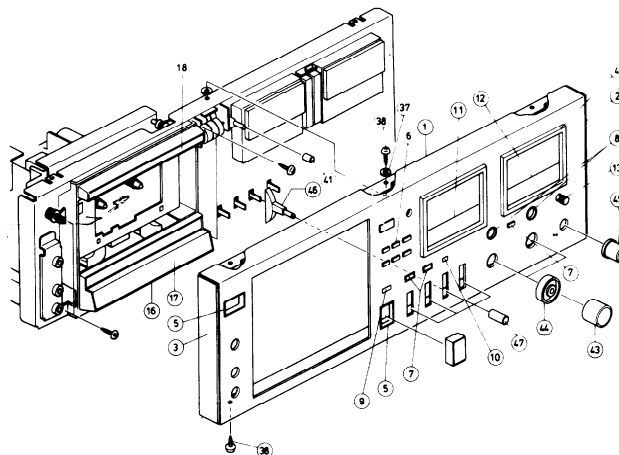
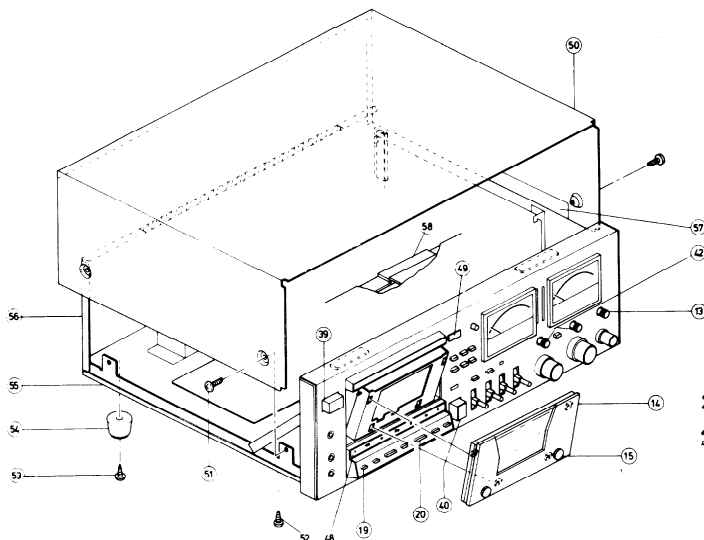

Fig. 17



27300143-1 METAL PLATE
 27300142 DOOR LID GLASS
 27300139A CASSETTE DOOR PLASTIC
 801189 SCREW DECORATION

Fig. 18

REF. NO.	PARTS NO.	DESCRIPTION	REF. NO.	PARTS NO.	DESCRIPTION
1	16429121-1	Front panel ass'y	→	210053	PL6V, 0.05A, Pilot lamp
2	28125060	End cap R	28	25035061A	NPS-121-L26P, Power switch (120V mdl)
3	28125061	End cap L		25035051	NPS-121-L16P, Power switch (Universal model)
4	27300141	Frame for meter			
5	27267027	Guide for power switch	29	270611	Lamp cover
6	16429718	Push switch guide A ass'y	30	243097	NIND-0500S97, Meter
	27267033	Push switch guide A	31	210067	RM5 12V, 30F, Pilot lamp
	28320270-1	Push switch knob A	32	210053	PL6V, 0.05A, Pilot lamp
	27180021	Spring	33	210045	PL6.3V, 0.1A, Pilot lamp
7	16429719	Push switch guide B ass'y	34	834130062	3STS+6BQ, Tapping screw
	27267034	Push switch guide B	35	16429561	NADIS-561, Peak indicator p.c.b. complete
	28320270-1	Push switch knob A			
	27180021	Spring	36	27110068C	Front bracket
8	27267026	Push switch guide	37	87644010	W4 x 10F(BC), Washer
9	28198514	Facet A	38	834430062	3STS+6BQ, Tapping screw
10	28198515	Facet D	39	28320287	Power switch knob
11	27300150	Plate	40	28320288	Eject knob
12	27300151	Plate	41	28320289	Push knob
13	28320291	Knob F ass'y	42	28320290	Volume knob
	27190042	Holder F	43	28320292	Knob L
	27180034	Spring	44	28320293	Knob R
	27267043	Guide F ?	45	28320294	Knob OUT
	893030	E-3, Circlip	46	28335010	Lever
14,15	16429603	Cassette panel ass'y	47	28320328	Knob for lever
14	27300139	Cassette door	48	27300146	Name plate (B)
	27300142	Door		28198516	Facet P
	27300143-1	Name plate for cassette door		28198517	Facet R
15	801189	Decoration screw		28198518	Facet PL
	870052	Washer	49	27300148A	Counter window
	28140203	Cushion	50	28184045	Cover
16	16429123	Operation frame ass'y	51	838440109	4TTB+10C(BC), Tap screw
	27300179-1	Operation frame	52	831130082	3STW+8BQ, Tapping screw
17	27300145B	Name plate (A)	53	834130102	3STS+10BQ, Tapping screw
18	27300147	Name plate (C)	54	27175009	Leg
19	28320269	Knob S	55	27170048A	Bottom board
20	28320268	Knob L	56	27120135-1	Back panel (120V model)
21	27300144	Lamp Holder		27120144	Back panel (Universal model)
22	210050	PL12V, 0.03A, Pilot lamp	57	28140024	Cushion
23	16429559	NASW-559, Switch p.c.b. complete	58	25045046	Stereo headphon Jack
24	27300149	Cushion	59	25045045	Mic. Jack
25	27130139A	Bracket	60	27140240	Bracket (S)
26	82113006	3P+6FN, Pan head screw			
27	244009-1	NDM-04, Deck mechanism complete			

ELECTRICAL ADJUSTMENT PROCEDURES

PRECAUTIONS

1. Tape required:

- | | | | |
|----------------|----------|-------------------------------|--|
| (1) Blank tape | | | |
| MAXELL | UD-XL/I | (Normal) | |
| | UD-XL/II | (High) | |
| SCOTCH | METAFINE | (Metal) | |
| (2) Test tape | | | |
| VICTOR | VTT-658 | 10 kHz, -15 dB | |
| TEAC | MTT-111 | 3 kHz, -10 dB | |
| | MTT-150 | Dolby level calibration tone. | |

2. Instrument required:

- (1) AC VTVM
- (2) Frequency counter
- (3) AF oscillator
- (4) Attenuator
- (5) Oscilloscope

3. The switches and controls should be set as follows unless otherwise specified.

- | | |
|-------------------------|---------|
| Tape bias selector | Normal |
| Tape equalizer selector | Normal |
| Dolby NR filter | Out |
| Source selector | Source |
| Mic. input level | Minimum |
| Output level | Maximum |
| Memory switch | Off |
| Timer switch | Off |
| Dolby rec. cal. switch | Off |
| Dolby rec. cal. level | Center |
| Fade out | Off |

1. Playback and recording amplifier level adjustment *EOR*

- 1) Connect the AC VTVM to the EOL and ~~SI~~ terminals. *EOL TO GROUND*
- 2) Press the Dolby recording calibration switch to ON *SI TO GROUND* position and adjust the line input volume for 500mV.
- 3) Connect the AC VTVM to the DOL and DOR terminals and adjust the ~~R133~~ *R221* and ~~R134~~ *R222* semi-fixed resistor for 500mV.
- 4) After adjustment, set the Dolby recording calibration switch to OFF position.

2. Head azimuth adjustment

- 1) Play the 10 kHz portion of the test tape VTT-658 back. Adjust the head azimuth adjusting screw for maximum V.T.V.M. read.
- 2) If the peak output reads of the right and left channels are different, set the screw to obtain the mechanical center between the peaks.
- 3) After adjustment, lock the screw with bond.

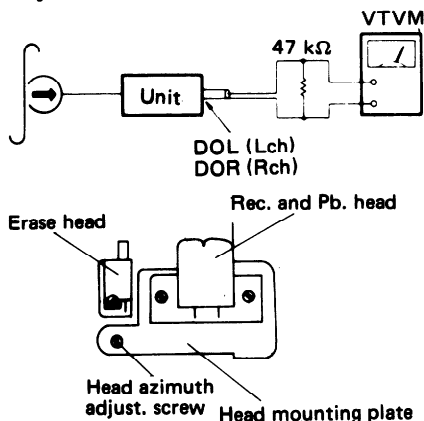

NOTES: Playback frequency adjust. semi-fixed resistor: center

3. Tape speed adjustment

PROCEDURES:

Play the 3 kHz portion of the test tape MTT-111 back. Adjust the tape speed adjusting semi-fixed resistor in the motor for 3,000 Hz counter indication.

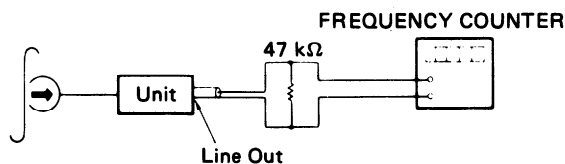

4. Playback output adjustment

- 1) Play the test tape MTT-150 back, adjust R133 and R134 for 775 mV V.T.V.M. read.
- 2) Proceed both for the left and right channels in the same manner.

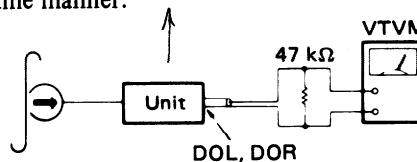

5. VU meter adjustment

- 1) Play the test tape MTT-150 back.
- 2) Adjust R363 and R364 until the VU meter pointer deflects to the Dolby mark (∞ , +3dB) on the meter.

6. Peak indicator adjustment

- 1) Play the test tape MTT-150 back.
- 2) Adjust the R365 and R366 until the indicator of L.E.D. array light up to the +3dB mark.

7. Peak indicator attenuator adjustment

- 1) Turn the Dolby recording calibration switch to ON position and adjust the line input volume until the indicator of L.E.D. array light up to the +7dB mark.
- 2) Turn the source selector switch to tape monitor and adjust R369 so as the left and right channel indicators go off at the same time.

Note: If this adjustment cannot, repeat the steps 6 and 7 as necessary.

8. Playback frequency adjustment

- 1) Set R131 to PM 2:00 position.
- 2) Play the test tape VTT-658 back and adjust R132 so as the same level in both channels.

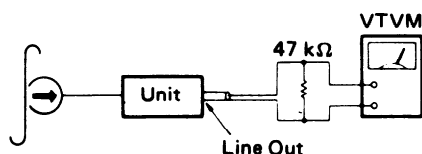
**9. Erase current adjustment**

- 1) Turn the bias selector switch to the metal position and press the auto accu-bias switch to ON position.
- 2) Connect the AC VTVM between the erase head (-) and E(earth) terminals.
- 3) Put the tape deck into recording mode and press the pause button.
- 4) Adjust R404 for 200mV (Minimum 180mV) erase current.
- 5) Press the auto. accu-bias switch to fixed position and adjust R563 for 180mV.

10. Bias current adjustment (Part-1)

- 1) Turn the bias selector switch to metal position.
- 2) Press the pause button and put the tape deck into the recording mode.
- 3) Connect the AC VTVM between the recording head (-) and E(Earth) terminal.
- 4) Adjust R299 and R300 for 14mV.
- 5) Turn the bias selector switch to high position.
- 6) Adjust R403 for 9mV.
- 7) Turn the bias selector switch to normal position.
- 8) Adjust R402 for 7mV.

11. Dolby decoder bias trap adjustment

- 1) Put the tape deck into recording mode.
- 2) Connect the AC VTVM to the line output terminals.
- 3) Adjust L101, and L102 for minimum output.

12. Bias trap adjustment

- 1) Connect the AC VTVM to the R297 and R298 test point terminals.
- 2) Put the tape deck into recording mode.
- 3) Adjust L113 and L114 for minimum voltage.

13. Dolby circuit adjustment

- 1) Connect the 5kHz, 10mV input signal to the line in terminal.
- 2) Connect the VTVM to the ~~EOL~~ and SI terminals.
- 3) Set the tape deck in the stop mode of operation.
- 4) Adjust the input level volume for 23.5mV VTVM read.
- 5) Turn the Dolby NR (MPX Filter) switch to ON.
- 6) Adjust R153 and 154 for 60mV VTVM read.

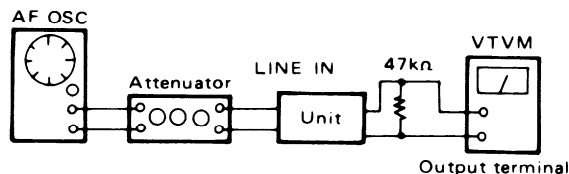
14. Recording bias current adjustment**14-1. Metal**

- 1) Turn the bias selector switch to the metal position.
- 2) Apply the 1,000Hz signal to the line input terminals.
- 3) Press the pause button and put the tape deck into recording mode.
- 4) Adjust the AF oscillator output so that the VU meter reads 0 VU.
- 5) Then set the attenuator for -20dB input level, and release the pause button to record on the tape.
- 6) Read the output level when the source selector is set to the source position.
- 7) Adjust R259 and R260 for same VTVM reading when the source selector is turned to tape monitor position.
- 8) Next change the frequency of 400Hz, and record again.
- 9) Read the output level when the source selector is set to the tape monitor.
- 10) Next change the frequency of the 10kHz and record again.
- 11) Adjust R299 and R300 so that the 400Hz and 10kHz level is same.

14-2. High

- 1) Turn the bias selector switch to the high position.
- 2) Apply the 1,000Hz signal to the line input terminals.
- 3) Press the pause button and put the tape deck into recording mode.
- 4) Adjust the AF oscillator output so that the VU meter reads 0 VU.
- 5) Then set the attenuator for -20dB input level, and release the pause button to record on the tape.
- 6) Read the output level when the source selector is set to the source position.
- 7) Adjust R257 and R258 for same VTVM reading when the source selector is turned to tape monitor position.
- 8) Next change the frequency of 400Hz, and record again.
- 9) Read the output level when the source selector is set to the tape monitor.

- 10) Next change the frequency of the 10kHz and record again.
- 11) Adjust the R403 so that the 400Hz and 10kHz level is same.

14-3 Normal

- 1) Turn the bias selector switch to the normal position.
- 2) Apply the 1,000Hz signal to the line input terminals.
- 3) Press the pause button and put the tape deck into recording mode.
- 4) Adjust the AF oscillator output so that the VU meter reads 0 VU.
- 5) Then set the attenuator for -20dB input level, and release the pause button to record on the tape.
- 6) Read the output level when the source selector is set to the source position.
- 7) Adjust R255 and R256 for same VTVM reading when the source selector is turned to tape monitor position.
- 8) Next change the frequency of 400Hz, and record again.
- 9) Read the output level when the source selector is set to the tape monitor.
- 10) Next change the frequency of the 10kHz and record again.
- 11) Adjust the R402 so that the 400Hz and 10kHz level is same.

- 2) Adjust the R527 so that the 400Hz and 10kHz mixing signal is same level (as shown below).
- 3) Adjust R529 for 100mV reading.

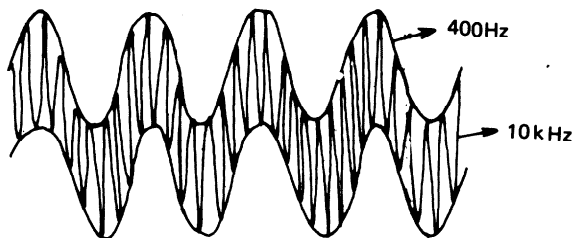

16. Accu. adjustment stop signal adjustment

- 1) Turn the bias selector switch to the normal position.
- 2) Press the auto. accu-bias switch to ON position.
- 3) Apply the 400Hz signal to the line input terminals.
- 4) Press the pause button and put the tape deck into recording mode.
- 5) Adjust the AF oscillator output so that the VU meter reads 0 VU.
- 6) Then set the attenuator for -20dB input level, and release the pause button to record on the tape.
- 7) Read the output level when the source selector is set to the source position.
- 8) Read the output level when the source selector is set to the tape monitor.
- 9) Next change the frequency of the 10kHz and record again.
- 10) Adjust the R516 so that the 400Hz and 10kHz level is same.

15. Accu. signal adjustment

- 1) Connect the oscilloscope and AC VTVM to the SO terminals.

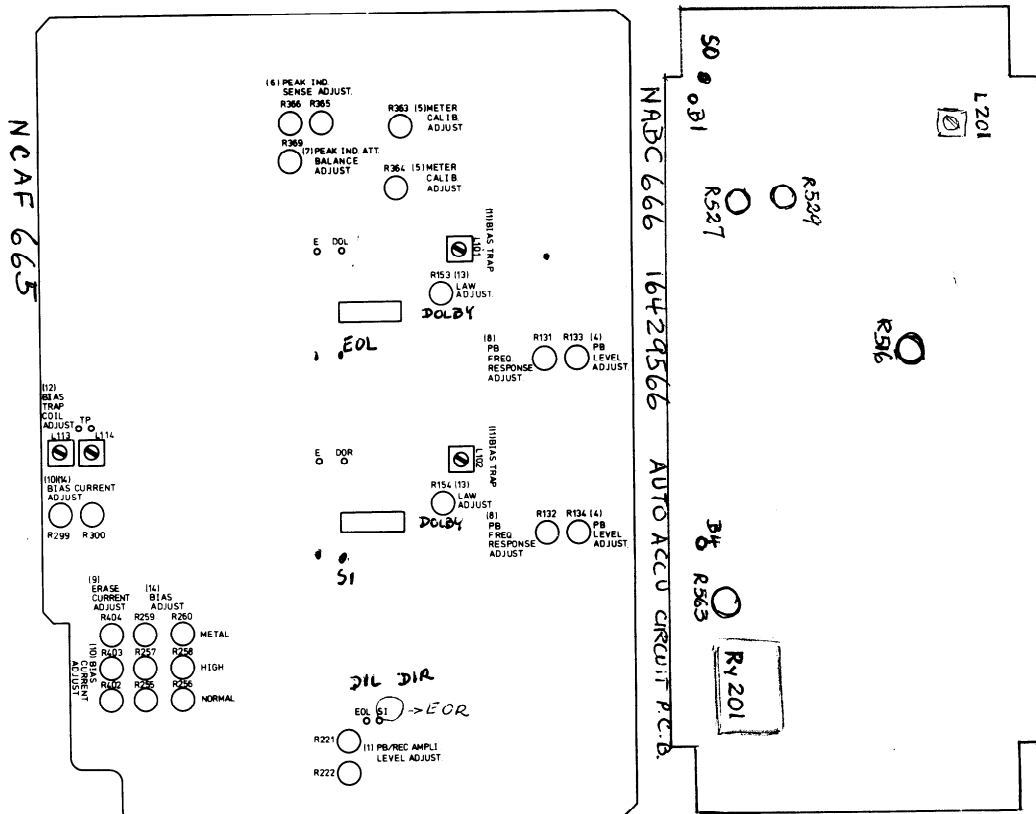

11. BLOC DIAGRAM
AMPLIFIER SECTION

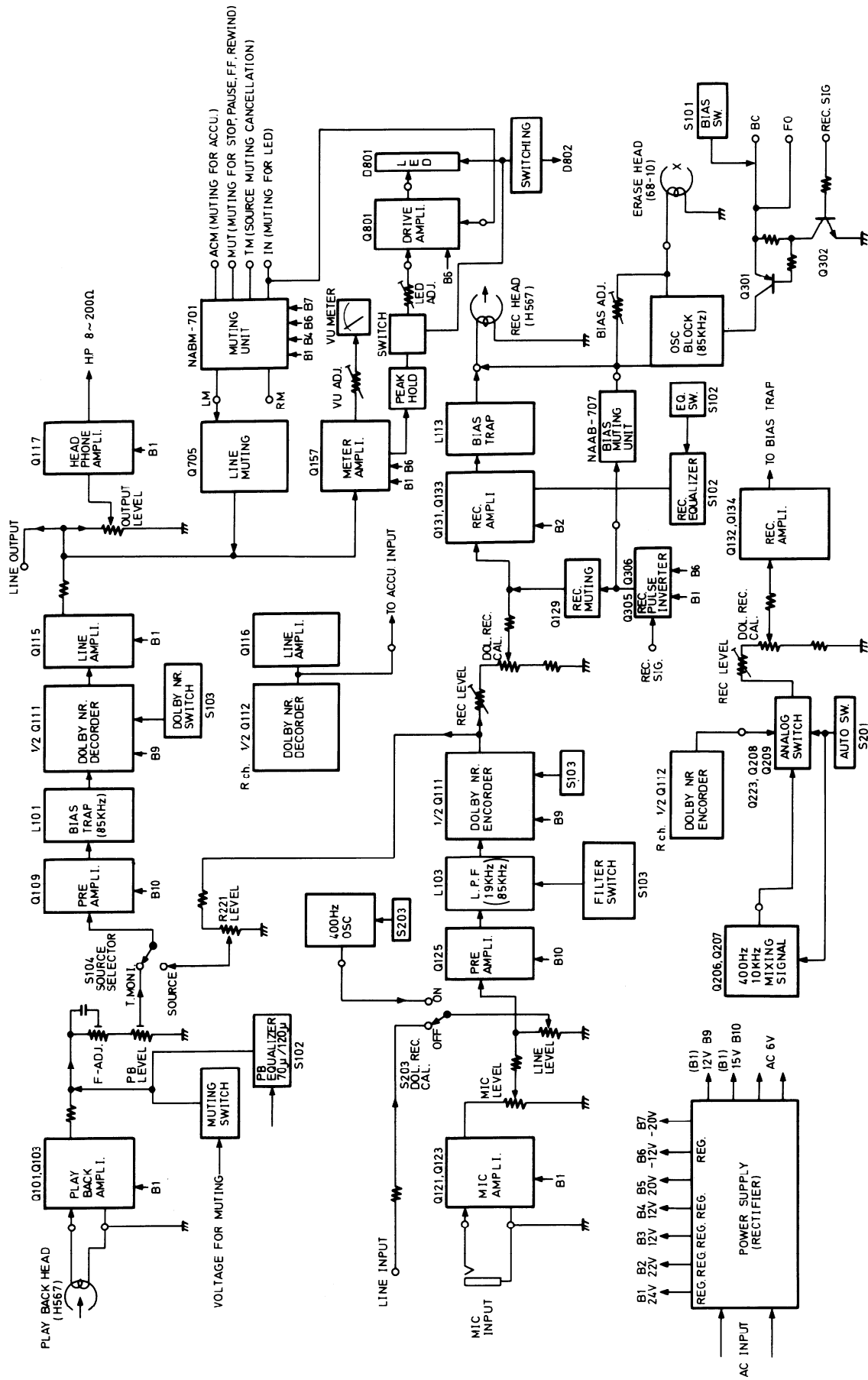

Fig. 21

CONTROL SECTION

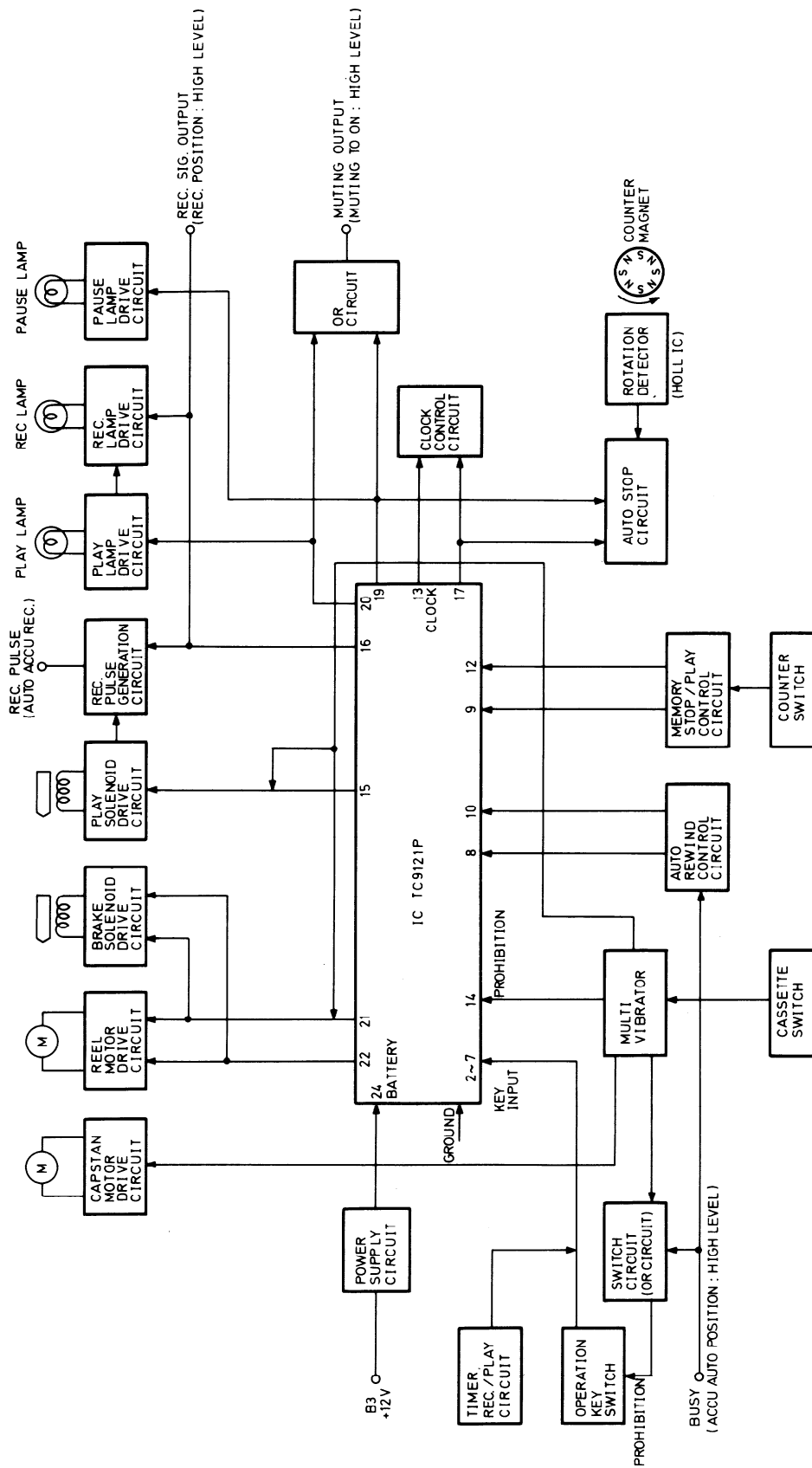
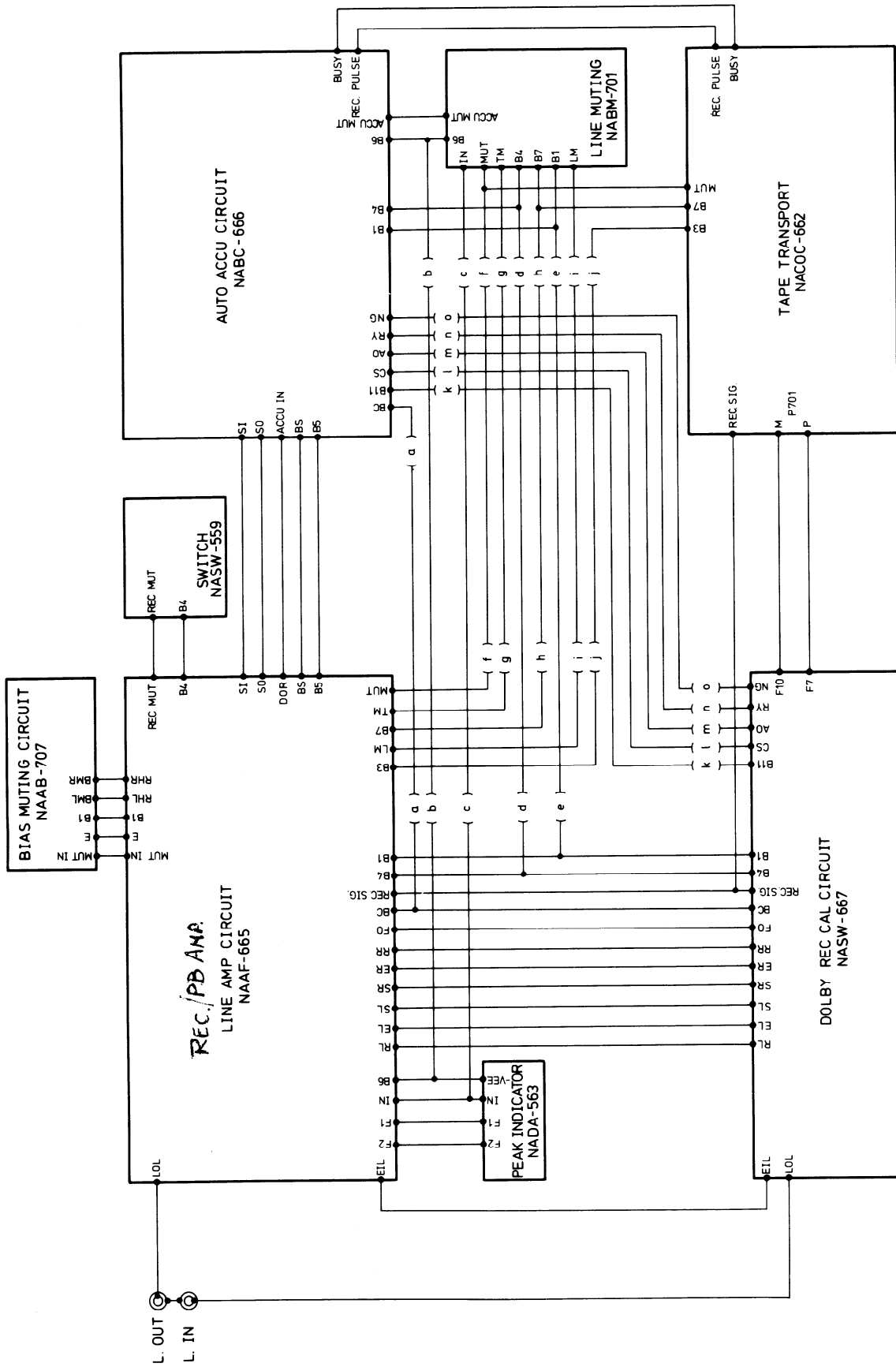
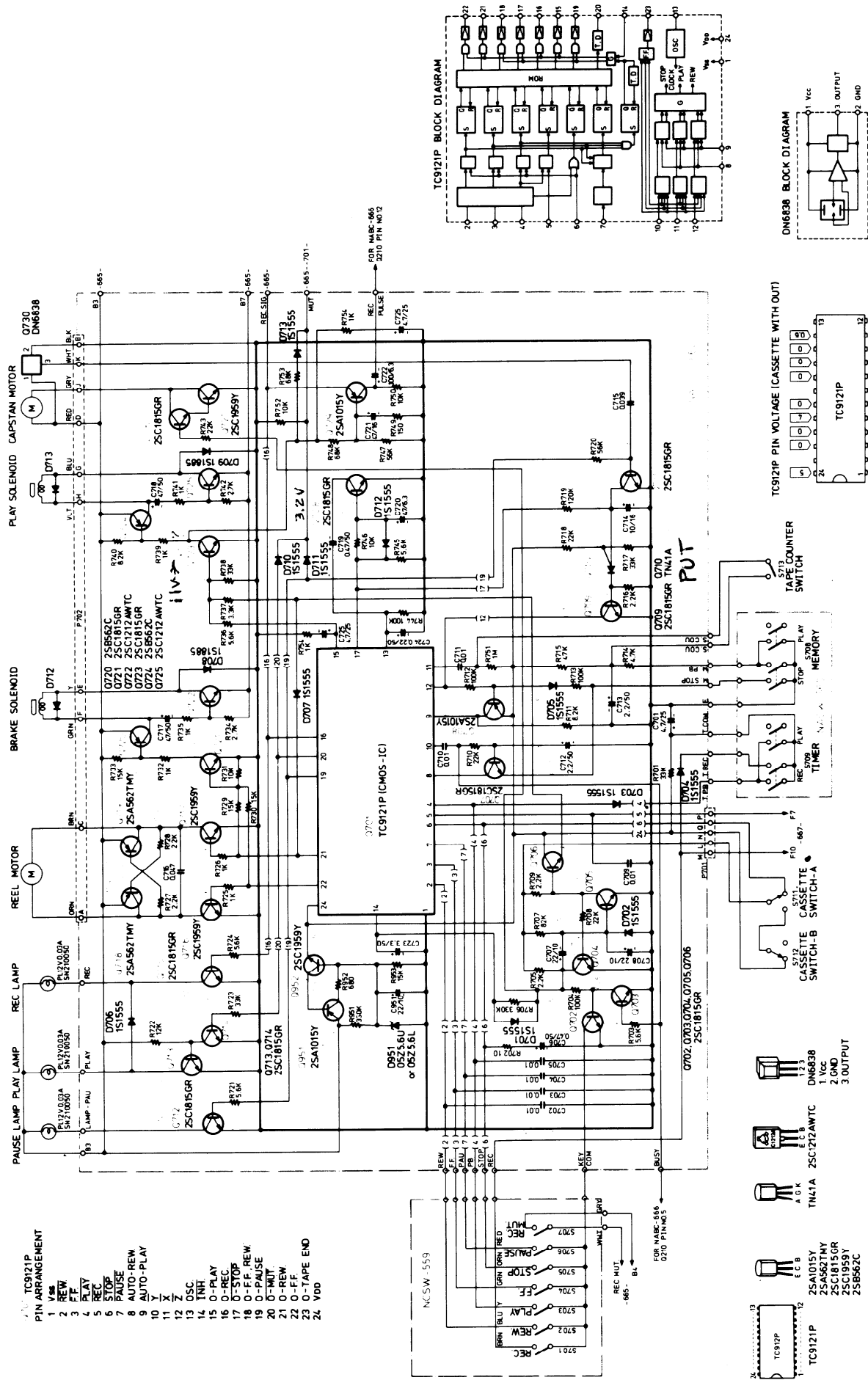

Fig. 22

CONNECTION DIAGRAM



MECHANISM OPERATION - SCHEMATIC DIAGRAM *NACOC-662*



- TC9121P
PIN ARRANGEMENT
- 1 REW
 - 2 F.F
 - 3 PLAY
 - 4 STOP
 - 5 REC
 - 6 PAUSE
 - 7 AUTO-PLAY
 - 8 AUTO-REW
 - 9 PAUSE
 - 10 F.F
 - 11 STOP
 - 12 REC
 - 13 OSC
 - 14 TNH
 - 15 D-PLAY
 - 16 D-REC
 - 17 D-STOP
 - 18 D-F.F
 - 19 D-PAUSE
 - 20 D-REW
 - 21 D-REC
 - 22 D-F.F
 - 23 D-PAUSE
 - 24 VDD

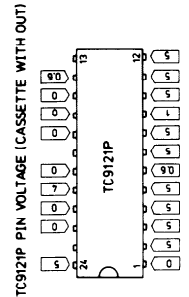
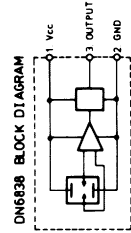
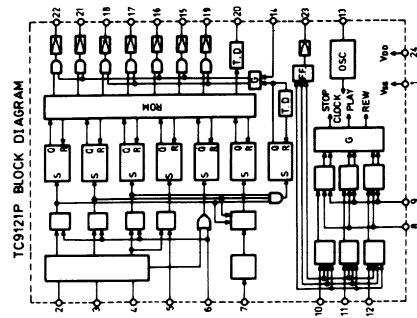

- S701 REC. KEY
- S702 REW KEY
- S703 PLAY KEY
- S704 F.F. KEY
- S705 STOP KEY
- S706 PAUSE KEY
- S707 REC. MUT. KEY
- S708 MEMORY SWITCH (OFF)
- S709 TIMER SWITCH (OFF)
- S710 ERASURE PREVENTION SW. (CASSETTE WITH OUT)
- S711 CASSETTE SWITCH A (CASSETTE WITH OUT)
- S712 CASSETTE SWITCH B (CASSETTE WITH OUT)
- S713 TAPE COUNTER SWITCH

- NOTES:
- ALL RESISTORS ARE IN OHMS 1/4 WATTS.
 - ALL CAPACITORS ARE IN JUF 50W V.
 - ELECTROLYTIC CAPACITORS (2-8-) ARE IN JUF/WV.
 - VOLTAGE ARE MEASURED WITH V.T.V.M. (WITH OUT CASSETTE TAPE) UNIT.

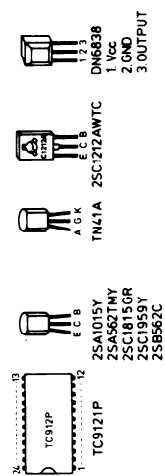

FOR NARC-666
0270 PIN NO.2

FOR NARC-666
0270 PIN NO.5

FOR NARC-666
0270 PIN NO.6

CIRCUIT NO.	PARTS NO.	DESCRIPTION	CIRCUIT NO.	PARTS NO.	DESCRIPTION
Q701	IC 222506MOS	TC-9121P $\frac{1}{2}$ S.O.8	P701	Plugs 25065055	NPLG-5P11
Q702-Q707	Transistors	2SC1815(GR)	P702	25065056	NPLG-10P12
Q708	2211255	2SA1015(Y)	TAPE DECK CONTROL SWITCH PC BOARD (NASW-559) - PARTS LIST		
Q709	2211454	2SC1815(GR)	CIRCUIT NO. PARTS NO. DESCRIPTION		
Q710	2211255	TN41A	Switches		
Q711-Q715	2211255	2SC1815(GR)	S701-S707	25035089	NPS-111-554
Q716, Q717	2211544	2SC1959(Y)	TIMER/MEMORY SWITCH PC BOARD (NASW-560) - PARTS LIST		
Q718, Q719	2211554	2SA562TMY	CIRCUIT NO. PARTS NO. DESCRIPTION		
Q720	2211563	2SB562(C)	S708, S709	25035090	NPS-321-L55, Switch
Q721	2211255	2SC1815(GR)	PEAK INDICATOR PC BOARD (NADIS-561) - PARTS LIST		
Q722	2210863	2SC1212AWTC	CIRCUIT NO. PARTS NO. DESCRIPTION		
Q723	2211255	2SC1815(GR)	D801, D802	225023	TLR-401, Diode array
Q724	2211563	2SB562(C)	PEAK INDICATOR DRIVE CIRCUIT (NADA-563) - PARTS LIST		
Q725	2210863	2SC1212AWTC	CIRCUIT NO. PARTS NO. DESCRIPTION		
Q726	2211255	2SC1815(GR)	Q801	222507	TA-7612P
Q727	2211544	2SC1959(Y)	Q802, Q803	Transistors	2SC1815(GR)
Q728	2211255	2SC1815(GR)	Q804, Q805	2211255	2SC1959(Y)
Q729, Q951	2211454	2SA1015(Y)	C801, C802	Capacitor	0.47 μ F, 50V, Elect.
Q952	2211544	2SC1959(Y)	NOTES:		
D701-D707	Diodes	1S1555	1. Voltage are measured with V. T. V. M. at the stop position.		
D708, D709	223105	1S1885	2. Capacitors		
D710-D713	223105	1S1555	DE: Non-inductive polyester film capacitor.		
D951	224041	05Z5.6U	ST: Polystyren film capacitor.		
C701	Capacitors	4.7 μ F, 25V, Elect.	LL: Low Leakage current type electrolytic capacitor.		
C706	352750471	0.47 μ F, 50V, Elect.	PP: Polypropylene capacitor.		
C707, C708	352784791	22 μ F, 10V, Elect.			
C712, C713	352732201	2.2 μ F, 50V, Elect.			
C714	352780221	10 μ F, 16V, Elect.			
C717, C718	352741001	47 μ F, 50V, Elect.			
C719	352784701	0.47 μ F, 50V, Elect.			
C720	352724701	47 μ F, 6.3V, Elect.			
C721	352744701	47 μ F, 16V, Elect.			
C722	352721011	100 μ F, 6.3V, Elect.			
C723	352780331	3.3 μ F, 50V, Elect.			
C724	392882297	0.22 μ F, 50V, LL			
C725	352750471	4.7 μ F, 25V, Elect.			
C951	352732201	22 μ F, 10V, Elect.			

16. AUTO-ACCU. BIAS PC BOARD VIEW FROM BOTTOM SIDE

AUTO ACCU. BIAS CONTROL CIRCUIT (NABC-666) – PARTS LIST

CIRCUIT NO.	PARTS NO.	DESCRIPTION	CIRCUIT NO.	PARTS NO.	DESCRIPTION
	ICs				
Q205	222424	TA-7504S	Q235	2210863	2SC1212AWTC
Q210	222510	TD3408AP	Q238	2211255	2SC1815(GR)
Q211	222512	TD3402AP			Diodes
Q233	222511	TD3493BP	D301-D304	223103	1N60
Q234	222545	μPC741C	D305	224038	05Z5.1L
	Transistors		D306-D310	223105	1S1555
Q201-Q204	2211255	2SC1815(GR)	D311,D312	223103	1N60
Q206,Q207	2211255	2SC1815(GR)	D313	224038	05Z5.1L
Q208,Q209	2210274	2SK30A(Y), F.E.T.	D314	223103	1N60
Q212,Q213	2211454	2SA1015(Y)	D315	223802	1S1885
Q220,Q221	2211255	2SC1815(GR)	D904	224038	05Z5.1L
Q222,Q223	2211454	2SA1015(Y)			Coil
Q224-Q227	2211255	2SC1815(GR)	L201	233146	NCH-4021
Q228	2211683	2SD468C			Capacitors
Q229-Q232	2211255	2SC1815(GR)	C401	352784791	0.47μF, 50V, Elect.

CIRCUIT NO.	PARTS NO.	DESCRIPTION
	Resistor	
R516	5225029	N10HR3.3KBD, Semi-fixed
R527	5225016	N10HR100KBD, Semi-fixed
R529	5225032	N10HR22KBD, Semi-fixed
R562,R583	441626804	68Ω, 1W, Metal
R563	5225033	N10HR33KBD, Semi-fixed
	Relay	
	25065063	NRL4P3ADC12-02

SWITCH PC BOARD (NASW-667) – PARTS LIST

CIRCUIT NO.	PARTS NO.	DESCRIPTION
	Transistors	
Q214-Q218	2211255	2SC1815(GR)
Q236	2211255	2SC1815(GR)
Q237	2211683	2SD468(C)
	Diode	
D316	223105	1S1555
	Capacitors	
C461	352750471	4.7μF, 25V, Elect.
C462	352751011	100μF, 25V, Elect.
	Resistors	
R263,R264	5104067	N16RLC30KB20, Variable
	Switches	
S201,S202	25035091	NPS-222-S56
S203	25035130	NPS-142-L94
S204	25035128	NPS-142-S93

BUFFER/MEMORY CIRCUIT PC BOARD (NABM-701) – PARTS LIST

CIRCUIT NO.	PARTS NO.	DESCRIPTION
	Transistors	
Q701-Q703	2211255	2SC1815(GR)
Q704	2211454	2SA1015(Y)
Q705,Q706	2211255	2SC1815(GR)
Q707	2210274	2SK30A(Y)
	Diodes	
D701-D704	223105	1S1555
	Capacitors	
C701	352742211	220μF, 16V, Elect.
C702	352751001	10μF, 25V, Elect.
C703	352742211	220μF, 16V, Elect.

MUTING CIRCUIT PC BOARD (NAAB-707) – PARTS LIST

CIRCUIT NO.	PARTS NO.	DESCRIPTION
	Transistor	
Q481-Q483	2211255	2SC1815(GR)
	Diode	
D481,D482	223105	1S1555
	Capacitor	
C481	352742211	220μF, 16V, Elect.

CIRCUIT NO.	PARTS NO.	DESCRIPTION
C402	352721011	100μF, 6.3V, Elect.
C409	352750471	4.7μF, 25V, Elect.
C418	352750471	4.7μF, 25V, Elect.
C419	352784791	0.47μF, 50V, Elect.
C420	352741001	10μF, 16V, Elect.
C421	352742201	22μF, 16V, Elect.
C427,C429	352780331	3.3μF, 50V, Elect.
C428,C430	352741001	10μF, 16V, Elect.
C434	352751011	100μF, 25V, Elect.
C437	352750471	4.7μF, 25V, Elect.
C439,C440	352780101	1μF, 50V, Elect.
C443,C445	352721011	100μF, 6.3V, Elect.
C447,C448	352750471	4.7μF, 25V, Elect.
C449	392882297	0.22μF, 50V, LL
C450	352780221	2.2μF, 50V, Elect.
C918	352721011	100μF, 6.3V, Elect.

NOTES:

1. Voltage are measured with V.T.V.M. at the stop position.
 2. Capacitors
- DE: Non-inductive polyester film capacitor.
 ST: Polystyren film capacitor.
 LL: Low Leakage current type electrolytic capacitor.
 PP: Polypropylene capacitor.

19. REC./PB AMPLI. PC BOARD – PARTS LIST

REC./PLAYBACK PC BOARD (NAAF-665) – PARTS LIST

CIRCUIT NO.	PARTS NO.	DESCRIPTION	CIRCUIT NO.	PARTS NO.	DESCRIPTION
ICs			C155,C156	352743301	33 μ F, 16V, Elect.
Q111,Q112	222460	HA-11226	C157	352741011	100 μ F, 16V, Elect.
Q117	222543	LA4170	C158	352741001	10 μ F, 16V, Elect.
Q157	222509	TA7318P	C159,C160	352734701	47 μ F, 10V, Elect.
Q901	222552	FS-7824M	C169,C170	392850477	4.7 μ F, 25V, LL
Q902	222549	FS-7812	C173,C174	352780221	2.2 μ F, 50V, Elect.
Q903	222542	FS-7812M	C175,C176	352741001	10 μ F, 16V, Elect.
Q904	222553	FS-7912M	C179-C182	352780331	3.3 μ F, 50V, Elect.
Transistors			C183,C184	352750471	4.7 μ F, 25V, Elect.
Q101-Q104	2211406	2SC2240(BL)	C187,C188	392883397	0.33 μ F, 50V, LL
Q105-Q108	2211255	2SC1815(GR)	C189,C190	373134723	4,700pF \pm 1%, 100V, PP
Q109,Q110	2211405	2SC2240(GR)	C191-C194	373131533	0.015 μ F \pm 1%, 100V, PP
Q115,Q116	2211255	2SC1815(GR)	C195,C196	392883397	0.33 μ F, 50V, LL
Q121-Q126	2211405	2SC2240(GR)	C199,C200	352741001	10 μ F, 16V, Elect.
Q129,Q130	2211255	2SC1815(GR)	C201-C204	352750471	4.7 μ F, 25V, Elect.
Q131-Q134	2211405	2SC2240(GR)	C205,C206	392882297	0.22 μ F, 50V, LL
Q135-Q140	2211255	2SC1815(GR)	C209	352741001	10 μ F, 16V, Elect.
Q151,Q152	2211454	2SA1015(Y)	C219,C220	352780471	4.7 μ F, 50V, Elect.
Q153,Q154	2211255	2SC1815(GR)	C226	352741001	10 μ F, 16V, Elect.
Q155,Q156	2211454	2SA1015(Y)	C227,C228	352780221	2.2 μ F, 50V, Elect.
Q301	2211563	2SB562(C)	C253,C254	392881097	0.1 μ F, 50V, LL
Q302,Q305	2211255	2SC1815(GR)	C255,C256	352780101	1 μ F, 50V, Elect.
Q306			C257,C258	352784791	0.47 μ F, 50V, Elect.
F.E.T.			C259,C260	352734701	47 μ F, 10V, Elect.
Q113,Q114	2210274	2SK30A(Y)	C301	352780221	2.2 μ F, 50V, Elect.
Q127,Q128			C303	352731011	100 μ F, 10V, Elect.
Diodes			C304,C305	374124725	4,700p \pm 10%, 50V, DE
D101,D102	2231031	1N60(N)FM	C306-C308	374121035	0.01 μ F \pm 10%, 50V, DE
D103,D104	223105	1S1555	C901	352781021	1,000 μ F \pm 50V, Elect.
D105,D106	2231031	1N60(N)FM	C903	352754701	47 μ F, 25V, Elect.
D107,D108	223105	1S1555	C908	352751021	1,000 μ F, 25V, Elect.
D109,D110	224039	05Z5.1U	C910	352744701	47 μ F, 16V, Elect.
D111,D112	223105	1S1555	C912	352744701	47 μ F, 16V, Elect.
D204			C913	352751021	1,000 μ F, 25V, Elect.
D901	223847	1B4B41	C915	352744701	47 μ F, 16V, Elect.
D903	223860	KBF02	C916	352744711	470 μ F, 16V, Elect.
Coils			C917	352741021	1,000 μ F, 16V, Elect.
L101,L102	233185	NCH-4031	C919	352762211	220 μ F, 35V, Elect.
L103,L104	233134-1	NMC-5009	C920	352741001	10 μ F, 16V, Elect.
L105,L106	233135	NMC-5010	Resistors		
L107,L108	233183	NCH-2029	R131-R134	5225034	N10HR47KBD, Semi-fixed
L109,L110	233184	NCH-2030	R153,R154	5225015	N10HR10KBD, Semi-fixed
L111,L112	233131	NCH-2018	R177,R178	5148020	N16RGM10KA30, Variable
L113,L114	233186	NCH-3032	R199,R200	5104068-1	N16RKL20KA35F, Variable
L118	233188	NCH-1033	R217,R218	5104066-1	N16RKL100KA35F, Mic. variable
Oscillator block			R221,R222	5225024	N10HR1KBD, Semi-fixed
L117	24606093	NOB-006	R255-R260	5225016	N10HR100KBD, Semi-fixed
Capacitors			R299,R300	5225034	N10HR47KBD, Semi-fixed
C101,C102	392850477	4.7 μ F, 25V, LL	R363,R364	5225026	N10HR470BD, Semi-fixed
C103,C104	352751001	10 μ F, 25V, Elect.	R365,R366	5225016	N10HR100KBD, Semi-fixed
C111,C112	352732201	22 μ F, 10V, Elect.	R369	5225032	N10HR22KBD, Semi-fixed
C113,C114	392880107	1 μ F, 50V, LL	R402-R404	5225032	N10HR22KBD, Semi-fixed
C121,C122	352780331	3.3 μ F, 50V, Elect.	Switches		
C123,C124	352750471	4.7 μ F, 25V, Elect.	S101	25040050	NLS-123-2715-L25, Bias selector
C127,C128	392883397	0.33 μ F, 50V, LL	S102	25040049	NLS-143-2715-L24, Equalizer selector
C129,C130	373134723	4,700pF \pm 1%, 100V, PP	S103	25040045	NLS-163-2715-L21, Dolby NR filter
C131,C132	373131533	0.015 μ F \pm 1%, 100V, PP	S104	25040063	NLS-142-2715-L37, Source selector
C133,C134	352744711	470 μ F, 16V, Elect.	Radiator		
C135,C136	373131533	0.015 μ F \pm 1%, 100V, PP	27160029A		
C137,C138	352741001	10 μ F, 16V, Elect.	NOTES:		
C139,C140	392883397	0.33 μ F, 50V, LL	1. Voltage are measured with V.T.V.M. at the stop position.		
C143,C144	352741001	10 μ F, 16V, Elect.	2. Capacitors		
C145-C150	352750471	4.7 μ F, 25V, Elect.	DE: Non-inductive polyester film capacitor.		
C151	352781011	100 μ F, 50V, Elect.	ST: Polystyrene film capacitor.		
C153,C154	352750471	4.7 μ F, 25V, Elect.	LL: Low Leakage current type electrolytic capacitor.		
			PP: Polypropylene capacitor.		

20. PACKING PROCEDURES

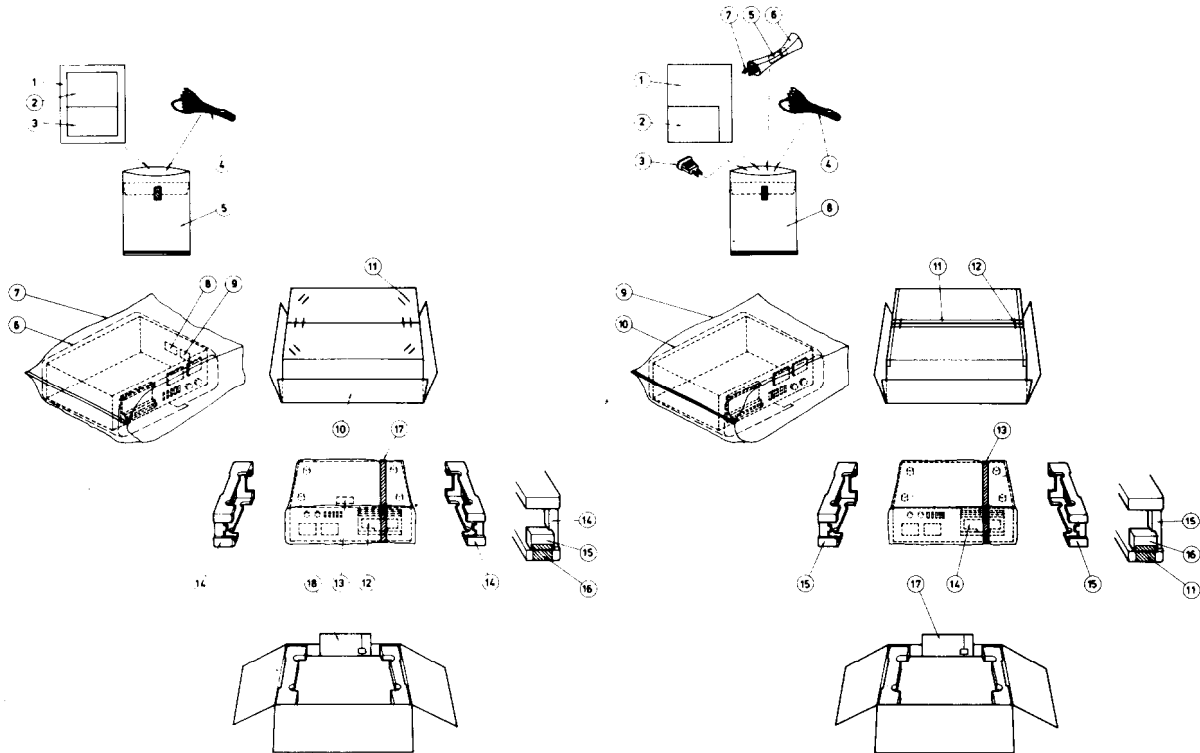

120V model

REF. NO.	PARTS NO.	DESCRIPTION
1	29340337	Instruction manual
2	29358002	Service station list (USA)
3	29365006	Warranty card (USA)
4	253074	Connection cord
5	29100005	330 x 220mm, Poly bag
6	290093	500 x 1,200mm, Protection sheet
7	29100034	850 x 650mm, Poly bag
8	282969	Caution label A (USA)
9	29380040	Cabinet composite label (USA)
10	29050222-1	Carton box
11	282301	Sealing hook
12	29095116	Protection sheet
13	293041	Caution label (USA)
14	29090352	Pad
15	29090434A	Pad
16	260012	W = 50mm, Damplon tape
17	261504	W = 30mm, Adhesive tape
18	16429119	Accessory bag

Note: (USA): only U.S.A. model

Universal model

REF. NO.	PARTS NO.	DESCRIPTION
1	29340351	Instruction manual
2	29365005-1	Warranty card (G)
3	25055018	Conversion plug (U)
4	253074	Connection cord
5	29380038	Voltage tag
6	290076	Paper for 7
7	13876801	Power supply cord (U)
	253089	Power supply cord (G)
8	29100006	350 x 250mm, Poly bag
9	29100034	850 x 650mm, Poly bag
10	290093	500 x 1,200mm, Protection sheet
11	260012	W = 50mm, Damplon tape
12	282301	Sealing hook
13	261504	W = 30mm, Tape
14	29095116	Protection sheet
15	29090352	Pad
16	29090434A	Pad
17		Accessory bag

Note: (U): Only Universal model
(G): Only Germany model

ONKYO CORPORATION

International Division: No. 24 Mori Bldg., 23-5, 3-chome, Nishi-Shinbashi, Minato-ku, Tokyo, Japan
Telex: 2423551 ONKYO J. Phone: 03-432-6981

ONKYO U.S.A. CORPORATION

Eastern Office
42-07 20th Avenue, Long Island City, New York 11105, U.S.A. Phone: (212) 728-4639

Midwest Office
935 Sivert Drive, Wooddale, Illinois 60191, U.S.A. Phone: (312) 595-2970

ONKYO DEUTSCHLAND GMBH, ELECTRONICS

8034 München-Germering, Industriestrasse 18, West Germany. Telex: 521726 Telefon: (089)-84-5041

AUTO-ACCU. BIAS - SCHEMATIC DIAGRAM

NOTE VOLTAGE IN STOP POSITION AND ACCU ON UNIT Y.

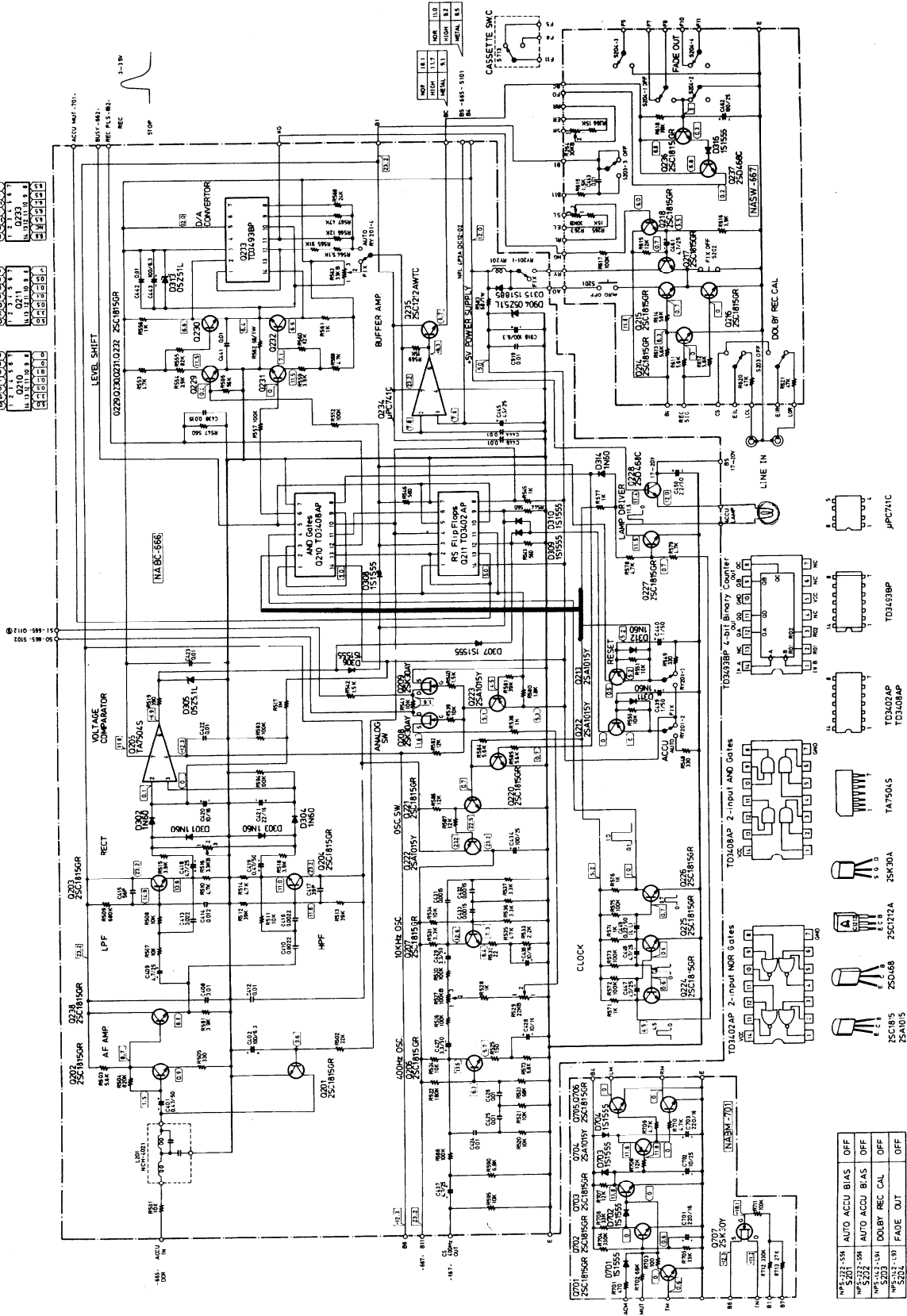

10. MECHANISM EXPLODED VIEW

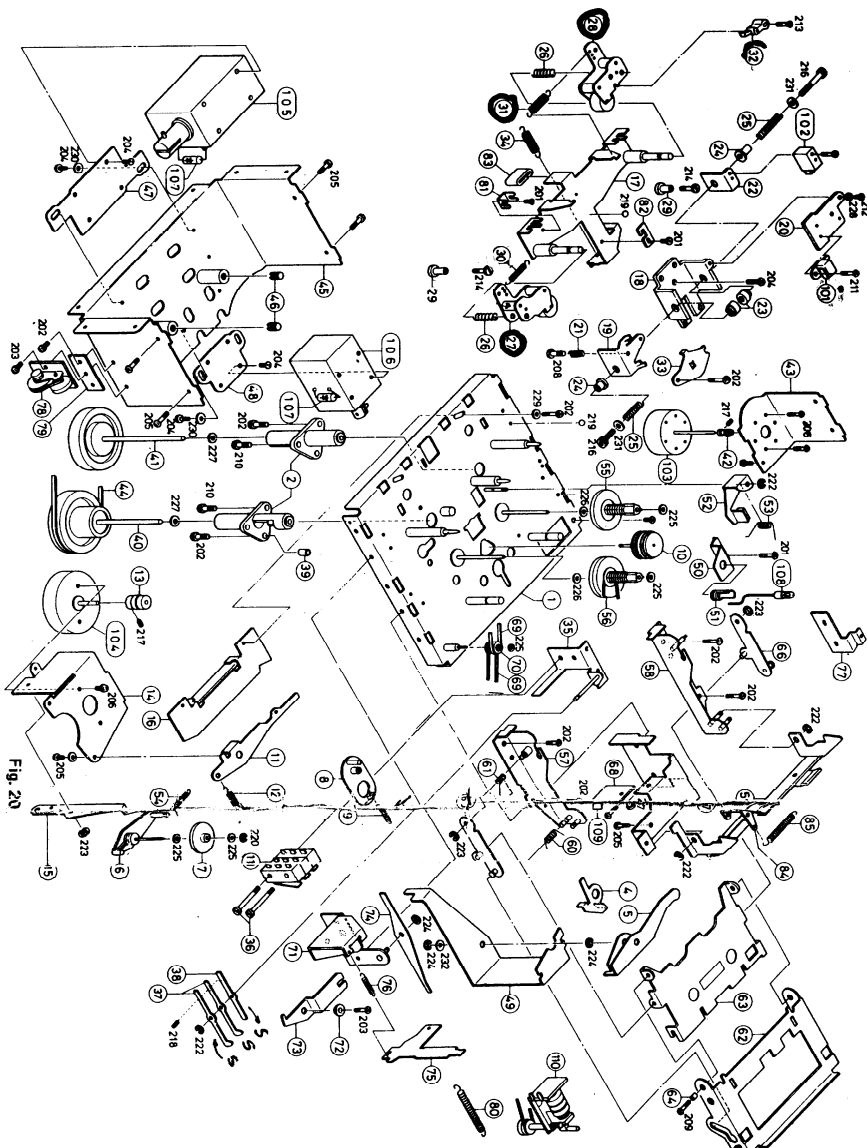

REF. NO.	PARTS NO.	DESCRIPTION
1	24610231	Chassis
2	24610232	Beam, capstan
3	24603103	Cancellation lever, idler
4	24603104	Play lever
5	24602033	Guide, play idler
6	24602035	Guide, fastforward/rewind idler
7	24610234	Spring for B
8	24602034	FR lever ass'y
9	24602035	Spring for B
10	24603105	Motor pulley ass'y
11	24601038	Spring for 11
12	24603106	Bracket, motor
13	24603106	Plunger lever B
14	24603106	Stop plate B
15	24610236	Sub-chassis ass'y
16	24610237	Rest, head
17	24610238	Rest, head
18	24610239	Head azimuth rest
19	24605146	Spring for 19
20	24610242	Extra head rest
21	24610243	Nut, head rest
22		
23		

REF. NO.	PARTS NO.	DESCRIPTION
24	24610244	Collar, head rest
25	24605147	Spring for 24
26	24605148	Head azimuth spring
27	24610245	Pinch arm R ass'y
28	24610246	Pinch arm L ass'y
29	24610247	Adjustment nail
30	24605149	Spring for 27
31	24605150	Print roller spring
32	24610250	Print guide
33	24610251	Spring for 32
34	24610252	Stamp, 1/2" ball
35	24610253	Stamp holder
36	24610254	Screw for switch
37	24603108	Lever B
38	24603108	Drive pulley
39	24610254	Flywheel L
40	24602057	Flywheel R
41	24602058	P motor pulley
42	24601039	Plate for P motor
43	24510256	Drive belt
44	24610255	Drive belt
45	24610251	Screw
46		

REF. NO.	PARTS NO.	DESCRIPTION
47	24610258	Solenoid plate A
48	24602059	Solenoid plate B
49	24603109	P coupled lever
50	24610260	Lamp holder
51	24610261	Rubber bush
52	24610262	Tension plate
53	24602063	Tension spring
54	24602064	FR pulley
55	24602065	FR pulley spring
56	24602066	FR pulley base
57	24610265	Bracket L
58	24610265	Bracket R
59	24605154	Lock plate spring
60	24605155	Door arm spring
61	24610266	Cassette case B
62	24610267	Cassette panel
63	24610267	Collar
64	24610191	Door arm B (Right)
65	24610268	Door arm B (Left)
66	24610270	Holder for counter
67	24605091	IC P.c.b.
68	24602062	Counter belt
69		

REF. NO.	PARTS NO.	DESCRIPTION
70	24601040	Motor pulley B
71	24610271	Eject holder ass'y
72	24604032	Pause lever collar
73	24603111	Pause lever
74	24603112	Cancellation lever
75	24603113	Button lever
76	24605089	Inter lock spring
77	24610272	Bracket
78	24610182	Pulley ass'y
79	24610274	Plate
80	24610275	Stringing ass'y
81	24610248	Hold, wire
82	24610249	Timing plate
83	24603110	Clutch
84	24605156	Lever
85	24605156	Spring
101	24600013	R/P head
102	24600014	E head
103	24601041	P motor
104	24601042	FR motor
105	24606085	Solenoid B
106	24606086	Solenoid C
107	22386585	1N4001, Diode
108	24606088	Lamp
109	222870	Diode
110	24601043	Counter
111	24606090	Microswitch
201	801117	M2.6 x 4.5 Screw
202	801117	M2.6 x 4.5 Screw
203	801181	M2.6 x 6 Screw
204	801182	M3 x 6 Screw
205	801180	M3 x 6 Screw
206	82112603	M2.6 x 3.5 Screw
207	82112604	M2.6 x 4.5 Screw
208	82112608	M2.6 x 8 Screw
209	8252605	M2.6 x 6.5 Screw
210	82212605	M2.6 x 5.5 Screw
211	801199	M2 x 3.5 Screw
212	801184	M2 x 3.5 Screw
213	801200	M2 x 12 Screw
214	801203	M2 x 12 Screw
215	801205	M2 x 12 Screw
216	801202	M2 x 3.5 Screw
217	801204	M3 x 6.5 Screw
218	24610279	3φ Steelball
219	891012	E1.2, Circlip
220	891015	E1.2, Circlip
221	891020	E2.5, Circlip
222	891025	E2.5, Circlip
223	891025	E2.5, Circlip
224	891030	E3.5, Circlip
225	24610216	1.7 x 3.2, Poly slider washer
226	24610217	2.2 x 6, Nylon washer
227	826122504	3.2 x 4.5, Washer
228	826122504	3.2 x 4.5, Washer
229	826122505	3.2 x 4.5, Washer
230	826122505	3.2 x 4.5, Washer
231	826122505	3.2 x 4.5, Washer
232	826122505	3.2 x 4.5, Washer
233	826122505	3.2 x 4.5, Washer