

ONKYO SERVICE MANUAL

STEREO CASSETTE TAPE DECK MODEL TA-2130

Black models

UDN, UDC, UD	120V AC, 60Hz
UG	220V AC, 50Hz
UW	120 or 220V AC, 50/60Hz
UQA, UQB	240V AC, 50Hz

SAFETY-RELATED COMPONENT WARNING!!

COMPONENTS IDENTIFIED BY MARK \triangle ON THE SCHEMATIC DIAGRAM AND IN THE PARTS LIST ARE CRITICAL FOR RISK OF FIRE AND ELECTRIC SHOCK. REPLACE THESE COMPONENTS WITH ONKYO PARTS WHOSE PARTS NUMBERS APPEAR AS SHOWN IN THIS MANUAL.

MAKE LEAKAGE-CURRENT OR RESISTANCE MEASUREMENTS TO DETERMINE THAT EXPOSED PARTS ARE ACCEPTABLY INSULATED FROM THE SUPPLY CIRCUIT BEFORE RETURNING THE APPLIANCE TO THE CUSTOMER.

SPECIFICATIONS

Track System:	4-tracks, 2-channels
Erasing System:	AC erase
Tape Speed:	4.8 cm/sec (1-7/8 i.p.s.)
Wow and Flutter:	0.06% (WRMS)
Frequency Response:	20—15,000Hz (Normal) (30—14,000Hz \pm 3dB) 20—16,000Hz (High) (30—15,000Hz \pm 3dB) 20—17,000Hz (Metal) (30—16,000Hz \pm 3dB)
S/N Ratio:	Dolby NR off: 58dB (metal position tape) A noise reduction of 10dB above 5kHz and 5dB at 1kHz is possible with Dolby B NR. A noise reduction of 20dB at 5kHz is possible with Dolby C NR.
Input Jacks:	Microphone jacks: 2 Input sensitivity: 0.6mV/600 ohms Input impedance: 2.7 kohms Line IN: 2 Input sensitivity: 60mV Input impedance: 50 kohms
Outputs:	Headphone jack: 1 Optimum load impedance: 8 to 200 ohms Line OUT: 2 Standard output level: 500mV (0dB) Optimum load impedance: over 50 kohms
Motors:	DC servo motor x 1; DC motor x 1
Heads:	REC/PB: Special Hard Permalloy x 1; Erase head: Ferrite x 1



Power Supply Rating: AC 120V, 60Hz
 Power Consumption: 18 watts
 Dimensions: 435(W) x 112(H) x 262(D)mm
 (17-1/8" x 4-3/8" x 10-3/8")
 Weight: 4.1 kg. (9.1 lbs.)

Specifications and external appearance are subject to change without notice because of product improvements.

SERVICE PROCEDURES

1. Replacing the lamp

This unit used the lamp listed below.

Circuit No.	Parts No.	Description
PL901	210090	PL14V 150mA

Caution: Before replacing the lamp. Be sure to unplug the power supply cable.

2. Instruction resistance measurement

Connect the insulating-resistance tester between the plug of power supply cord and chassis.

Specifications; 500V more than 10MΩ

3. Replacement of power supply cord

There are two power supply cord outlets on the strainrelief. Insert them in prescribed direction to ensure safety. AS-UC-3 (UD<120V> model) should be inserted lengthwise and other types of cords should be inserted horizontally.

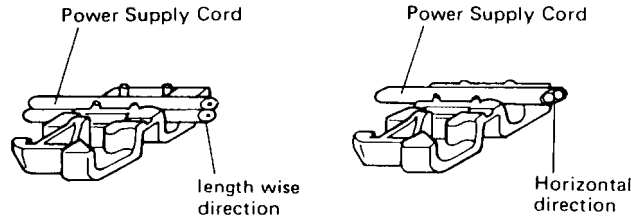

4. Replacing the Hall ICs

Cautions: As the position of leg of DN6838 and DN838K differ, use the same Hall IC when replacing.

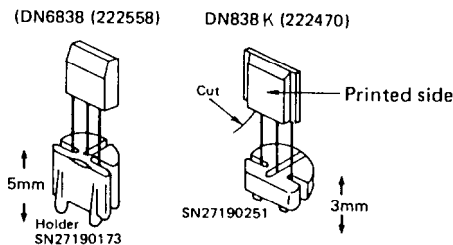

5. Method for removing BOTTOM BOARD (refer to exploded view of chassis)

1. Remove top cover.
2. Remove front panel.
3. Remove the 2 mounting screws of the main PC board (NAAF-2947-1).
4. Remove the 2 holders from the PC board.
5. Remove the 1 fastening screw of the Power Switch PC board (NAPS-2951-1).
6. Remove the holder from the PC board.
7. Remove the 4 fastening screws of the back panel and bottom board.
8. Remove the 3 fastening screws of the front bracket and bottom board.
9. Remove the ground terminal.
10. Remove the bottom board by taking from the lower direction.

6. Mechanism operation

This mechanism consists of a capstan motor, reel motor, and solenoid, with the power assist method by means of the capstan motor. In the operation, there are 3 conditions: STOP, PLAY, and CUE/REV. When the position is triggered by the solenoid, by means of intermittent rotation of the gear from the flywheel, as shown in Fig. 1, cyclic shifting is done.

To go from STOP to PLAY, if the solenoid is pulled in for 30ms, after about 150ms there is a shift to the PLAY condition. From this condition, if the solenoid is again pulled in, in that interval the condition shifts to CUE/REV. However, to suppress heat generation in the solenoid, the supply voltage must be reduced. If the power to the solenoid is cut off, the head lowers, and the condition goes to STOP. In order to have a cyclic operation as stated above, and to know the existing condition, a play switch is provided, and this switch is ON for PLAY and OFF for STOP (CUE/REV) is indefinite. When power is turned ON, the mechanism makes use of an initializer.

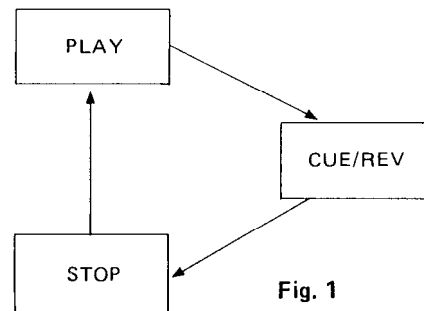
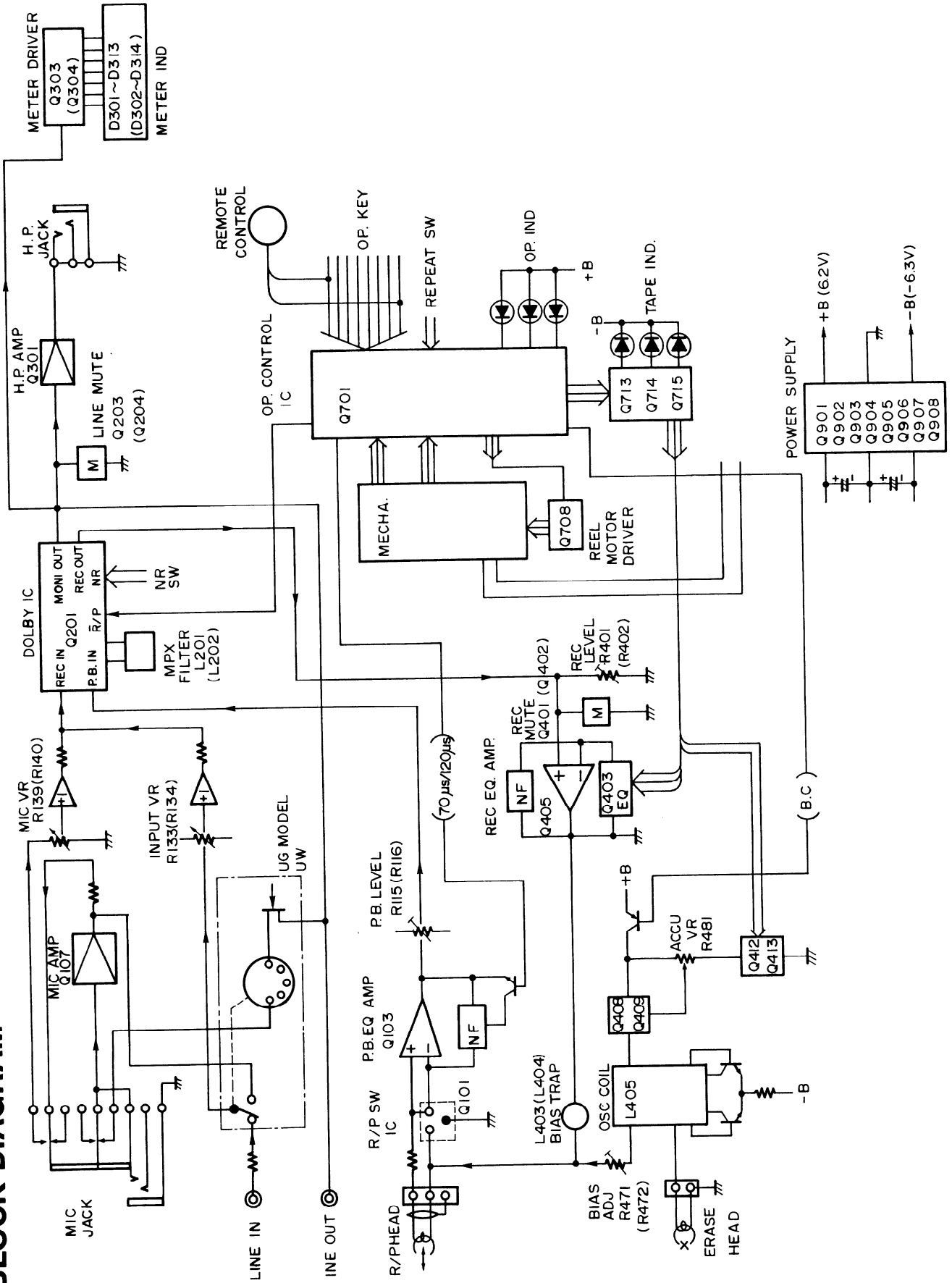

Fig. 1

BLOCK DIAGRAM



ADJUSTMENT PROCEDURES

PRECAUTIONS

- Before adjustment, clean the following parts with an alcohol moistend swab.
 - * record/playback head
 - * pinch roller
 - * erase head
 - * capstan
- Do not use magnetized screwdriver for adjustments.
- Demagnetize record/playback head with a head demagnetizer.

TEST EQUIPMENT/TOOLS REQUIRED:

Audio oscillator
Digital frequency counter

Oscilloscope

Attenuator

AC voltmeter

Non-magnetic screw driver

Blank tapes (completely erased)

NORMAL NEW UD90

HIGH NEW XL-II90

METAL NEW MX60

Test tapes

VTT-658 : 10 KHz, -15dB

MTT-111 : 3 kHz, -10dB

MTT-150 : Dolby level calibration
400Hz, tone 200nWb/m

Item	Connection of instrument	Line input	Test tape	Mode	Output indicator	Adjustment point	Adjust	Remarks
1	Tape speed Frequency counter to LINE output terminal		MTT-111	PB	Frequency counter	Semi-fixed on the motor	3,010 to 3,020Hz	
2	Head azimuth AC voltmeter and oscilloscope to LINE output terminal		VTT-658	PB	AC voltmeter	Head azimuth screw	Maximum and same phase at channels L and R	
3	Playback level AC voltmeter to terminals TP-1 and TP-2		MTT-150	PB	AC voltmeter	R-115(Ch.L) R-116(Ch.R)	245mV	
4	Bias frequency Frequency counter to P401. E head read (loose coupling)		METAL TAPE	REC	Frequency counter	L-405	85kHz	
6	Bias current AC voltmeter to LINE output terminal	1kHz, -20dB and 12kHz, -20dB	NEW XL-II90	REC/PB	AC voltmeter	R-471(Ch.L) R-472(Ch.R)	Same level at REC/PB	Input VR maximum
7	Record level Fig-1	1kHz		REC PAUSE	AC voltmeter	Attenuator of AF OSC output	350mV	Input VR maximum
				REC/PB	AC voltmeter	R-401(Ch.L) R-402(Ch.R)	Same level at REC/PB	
8	Clock Frequency counter to TP-5 10 : 1 cable				Frequency counter	R-722	160 to 170kHz	

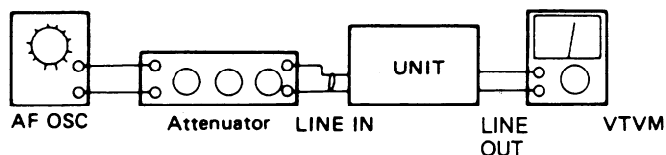
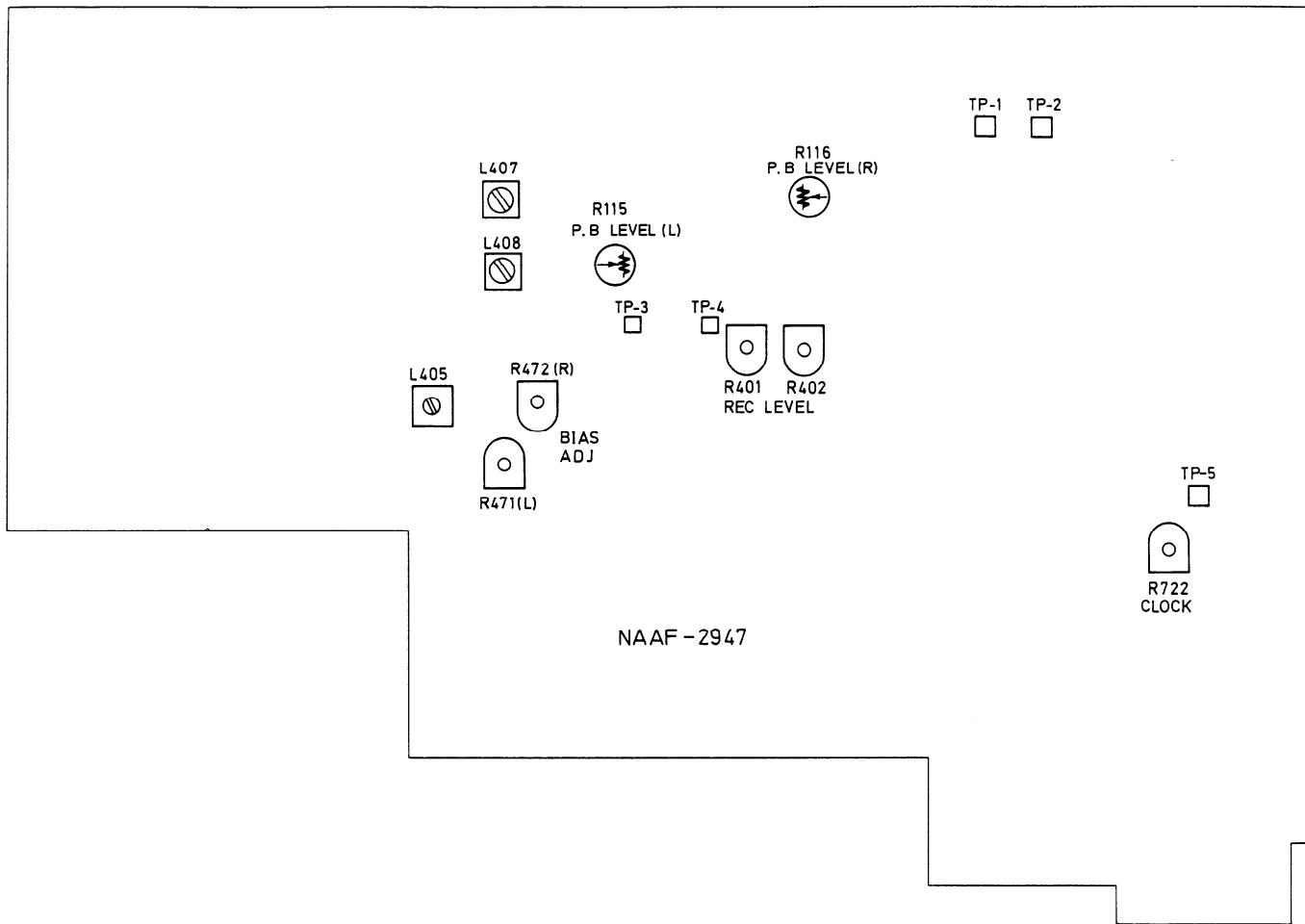
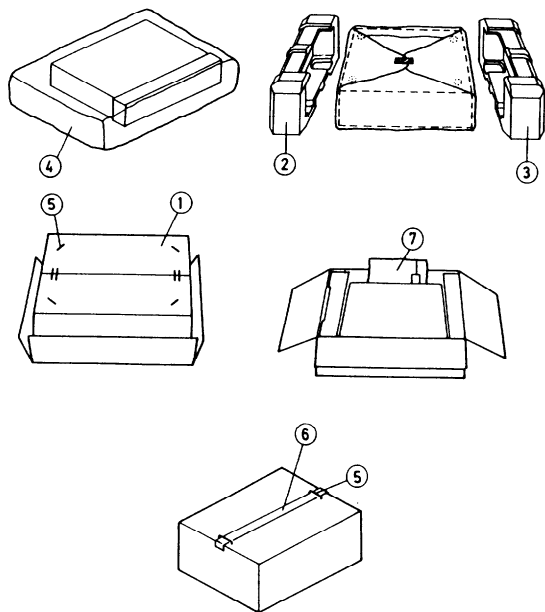

fig-1



PACKING VIEW



NOTE
 (N) : Only U.S.A. Model
 (W) : Only 120/220V Model

D MODEL

REF NO.	PART NO.	DESCRIPTION
1	29051517	Master carton box
2	29090987	Pad(L)
3	29090988	Pad(R)
4	29100037A	650 x 500 Poly bag
5	282301	Sealing hook
6	260012	Damplon tape
7	Accessory bag ass'y	
	29341145	Instruction manual
	2010095	Connection cable
	29365019	Waranty card (N)
	29358002E	Service station list (N)
	29100006A	350 x 250 Poly bag

G/W MODEL

REF NO.	PART NO.	DESCRIPTION
1	29051517	Master carton box
2	29090987	Pad(L)
3	29090988	Pad(R)
4	29100037A	650 x 500 Poly bag
5	282301	Sealing hook
6	260012	Damplon tape
7	Accessory bag ass'y	
	29341146	Instruction manual
	29341163	Instruction manual (I)
	2010095	Connection cable
	25055018	Conversion plug (CV-K-2) (W)
	29100006A	350 x 250 Poly bag

CHASSIS-EXPLODED VIEW-PARTS LIST

REF.NO.	PART NO.	DESCRIPTION	REF.NO.	PART NO.	DESCRIPTION
1	27110359	FRONT BRACKET AS	▲ P101	253099C	AS-UC-3, POWER SUPPLY CORD (D)
1-1	28194266	DECORATION PLATE (M)		253129A	AS-CEE, POWER SUPPLY CORD (G/W)
1-2	28322938	KNOB(SLIDE)AS		253118	AS-SAA, POWER SUPPLY CORD (Q)
2	24601176	COUNTER	S902	25065123	NSS-1258P, VOLTAGE SELECTOR (W)
3	27100122A	BOTTOM BOARD	Z1	244106	NDM-98, TAPE MECHANISM ASS'Y
4	27141120	BRACKET (C)	U1	1N003547-2	NAAF-2947-2, MAIN PC BOARD ASS'Y (D)
5	27273069A	JOINT (POW)		1N003547-2A	NAAF-2947-2A, MAIN PC BOARD ASS'Y (G/W/Q)
6	28133179	BACK PLATE		1N007549-1	NADIS-2949-1, PLAY BACK AMPLIFIER PC BOARD ASS'Y
7	28130245	INDICATOR PLATE	U2	1N007550-1	NAETC-2950-1, SEARCH AMP PC BOARD ASS'Y
8	27190520	HOLDER	▲ U4	1N007551-1	NAPS-2951-1, POWER SWITCH PC BOARD ASS'Y
10	27120985	BACK PANEL (D)	U5	1N007552-1	NAAR-2952-1, HEAD PHONE TERMINAL PC BOARD ASS'Y
	27120986	BACK PANEL (G)	U6	1N007554-1	NAAR-2954-1, REMOTE CONTROL PC BOARD ASS'Y
	27120988	BACK PANEL (W)	U7	1N003555-1	NAETC-2955-1, HALL IC PC BOARD ASS'Y
	27121018	BACK PANEL (Q)	U8	1N003543-4	NADIS-2943-4, DISPLAY PC BOARD ASS'Y
▲ 11	27300750	STRAINRELIEF	NOTE:	(D):	Only 120V model
13	86414010	FLANGE NUT FWN4X10FN		(G):	Only 220V model
14	28322940A	KNOB (SKIP)		(W):	Only 120V/220V model
15	28400312	CASSETTE LID		(Q):	Only 240V model
16	28400314	WINDOW			
17	27180272	SPRING (CA)			
18	28400282	DAMPER			
19	27180334	SPRING			
20	28184346-1	TOP COVER			
21	1N002121	FRONT PANEL			
24	28322946	KNOB (BAL)			
25	28322948	KNOB (VOL)			
26	28322795	KNOB (POW)			
27	28322970	KNOB AS (EJ)			
30	27190524	HOLDER			
31	28191397	CLEAR PLATE			
33	27175028	LEG			
34	834430088	TAP-TIGHT SCREW 3TTS+8BBC			
35	834430108	TAP-TIGHT SCREW 3TTS+10BB			
36	831130088	TAP-TIGHT SCREW 3TTW+8B			
37	833430080	TAP-TIGHT SCREW 3TTP+8PBC			
38	830440109	TAP-TIGHT SCREW 4TTC+10CB			
39	82142604	PAN-HEAD SCREW 2.6P+4F BC			
40	834230108	TAP-TIGHT SCREW 3TTS+10BN			
▲ T901	2300203	NPT-956D, POWER TRANSFORMER (D)			
	2300205	NPT-956G, POWER TRANSFORMER (G)			
	2300204	NPT-956DG, POWER TRANSFORMER (W)			
	2300241	NPT-956Q, POWER TRANSFORMER (Q)			

NOTE: THE COMPONENTS IDENTIFIED BY MARK ▲ ARE CRITICAL FOR RISK OF FIRE AND ELECTRIC SHOCK. REPLACE ONLY WITH PART NUMBER SPECIFIED.

CHASSIS-EXPLODED VIEW

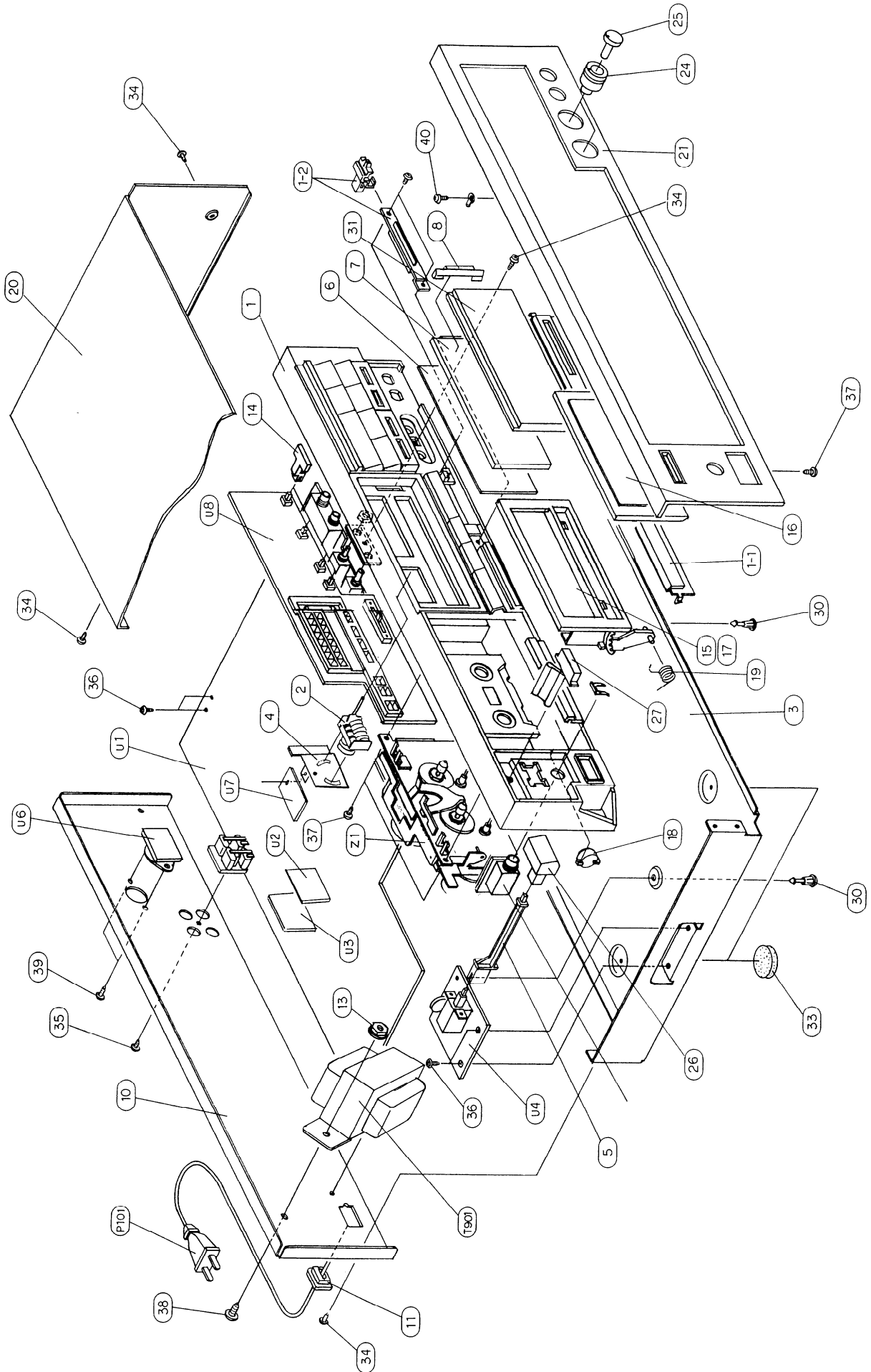

MICROCOMPUTER (LM6405L-1994)

In the microcomputer, the operating voltage is high with the NMOS type LM6405L using $V_{DD} = 6V$. The clock uses a condenser/resistor oscillator and is designed for a frequency of 170KHz. (Frequency measurement can be made by connection through a $100K\Omega \sim 330K\Omega$ to pin No. 1.)

Port No.	Name	Function
1	XTAL	Connected to resistor of oscillator for clock use
2	$\overline{\text{BIAS OUT}}$	Output port for turning bias oscillator ON/OFF: Oscillation with 0 level
3	$\overline{\text{LINE MUTE}}$	Output port for line muting: Muting with 0 level
4	$\overline{\text{REC. MUTE}}$	Output port for recording muting: Muting with 0 level
5	$\overline{\text{CASSETTE IN}}$	Input for cassette loading detection: Cassette loading with 0 level
6	ROTATION SENSOR	Pulse input rotation detection
7	$\overline{\text{RESET}}$	System reset for microcomputer use
8	CrO ₂	Input for automatic detection of chrome tape: Chrome use hole detection with 1 level
9	METAL	Input for automatic detection of metal tape: Metal use hole detection with 1 level
10	$\overline{\text{PLAY SWITCH}}$	Input for PLAY position detection: PLAY position with 0 level
11	REC. INH	Lug detection input for recording prevention: Disable with 1 level
12	REEL FF	Output for reel motor rotation in fast forward direction: Rotation with 1 level
13	REEL REW	Output for reel motor rotation in rewind direction: Rotation with 1 level
14	O PLAY	Reel motor rotation selection: Slow with 1 Fast with 0
15	$\overline{\text{PLAY LED}}$	LED output for PLAY indication: Lights with 0
16	$\overline{\text{PAUSE LED}}$	LED output for PAUSE indication: Lights with 0
17	$\overline{\text{REC LED}}$	LED output for REC indication: Lights with 0
18	$\overline{\text{SOL, P-UP}}$	Output for solenoid pull in: Pull in with 0
19	$\overline{\text{SOL}}$	Output for solenoid pull in hold (low power): Pull in hold with 0
20	TEST	Input for microcomputer chip inspection (Normally connected to V_{SS})
21	V_{SS}	Ground terminal
22	$70 \mu s / 120 \mu s$	For input to pins 8, 9, output for play back equalizer selection
23	$\overline{\text{NORMAL}}$	For input to pins 8, 9, output for record equalizer selection (NORMAL)
24	HIGH	For input to pins 8, 9, output for record equalizer selection (HIGH)
25	METAL	For input to pins 8, 9, output for record equalizer selection (METAL)
26	SINGLE SIG.	Input for recording signal detection for single repeat when in low speed
27	AMCS SIG.	Input for recording signal detection for AMCS use when in high speed
28	$\overline{\text{REPEAT OFF/ON}}$	Input for repeat operation ON/OFF: Operates with 0
29	$\overline{\text{SINGLE/FULL}}$	Selection of SINGLE/FULL operation: Full repeat with 0

Port No.	Name	Function
30	$\overline{P\ OFF}$	Input for power off detection: Off with 0
31	$\overline{TIMER\ REC}$	Input for timer recording ON/OFF: Operates with 0
32	$\overline{TIMER\ PLAY}$	Input for timer play back ON/OFF: Operates with 0
33	\overline{AMCS}	Key input to cause AMCS operation: Operation with 0
34	\overline{REW}	Key input to cause rewinding: Operation with 0
35	\overline{FF}	Key input to cause fast forward operation: Operation with 0
36	\overline{STOP}	Key input to cause stop operation: Operation with 0
37	$\overline{AUTO\ SPACE}$	Key input to cause auto space operation: Operation with 0
38	\overline{PAUSE}	Key input to cause pause or recording pause: Operation with 0
39	\overline{REC}	Key input pushed together with PLAY key to cause recording: Operation with 0
40	\overline{PLAY}	Key input for play back or recording: Operation with 0
41	V _{DD}	Power source terminal
42	EXTAL	Connects to resistor and condenser of oscillator for clock

NOTE 0: Low level
1: High level

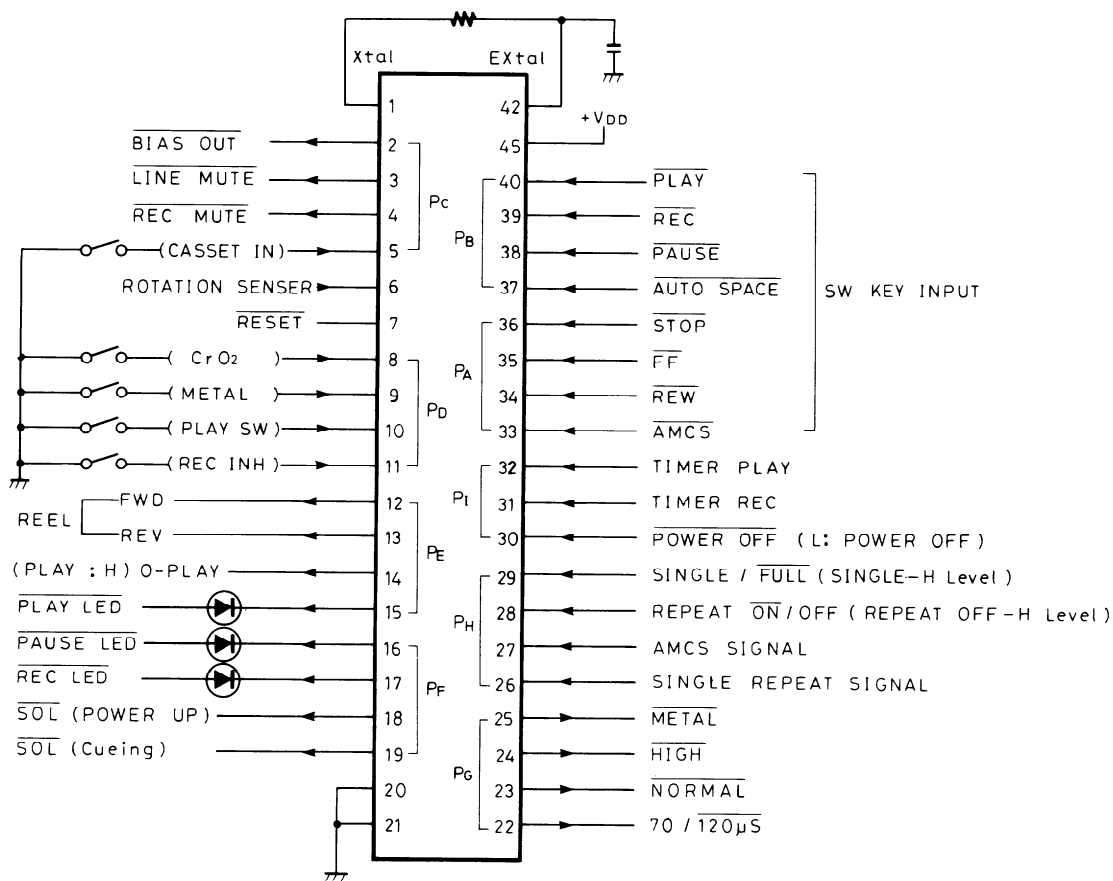

IC BLOCK DIAGRAM

NJM-2068D-D

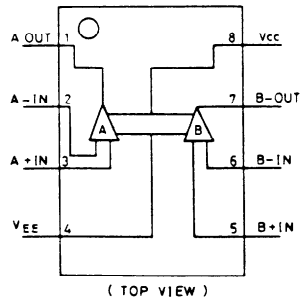
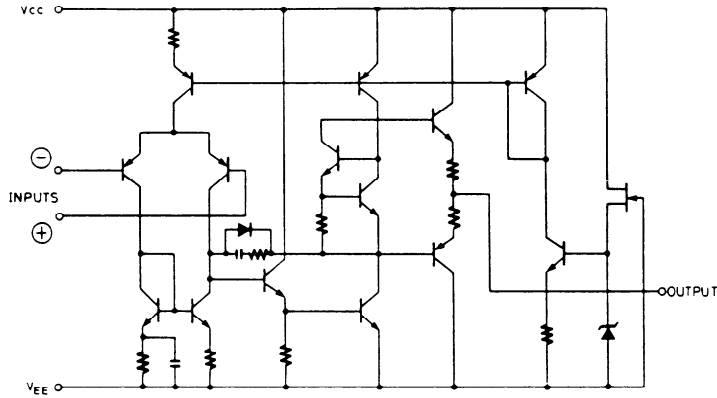

CX20187 (DOLBY N.R)

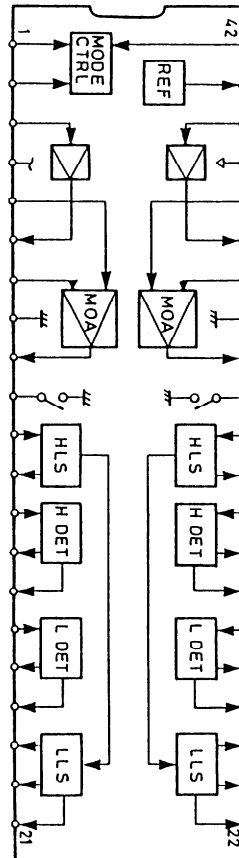
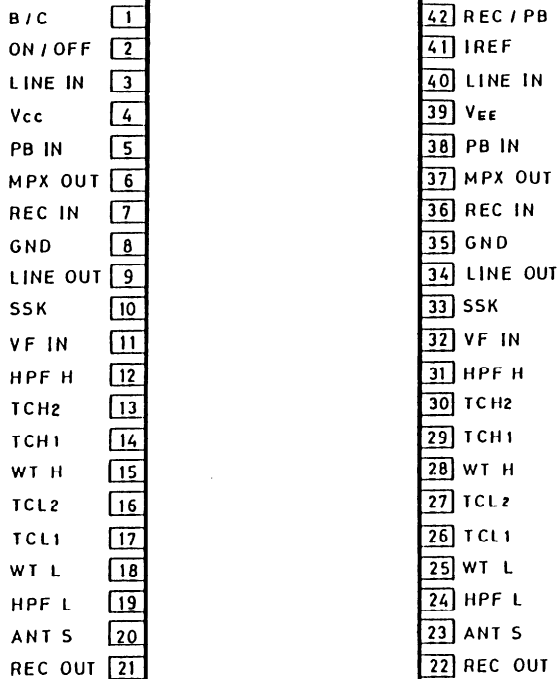

PRINTED CIRCUIT BOARD PARTS LIST

NAAF-2947-2

CIRCUIT NO.	PART NO.	DESCRIPTION			
	Ics		D107	223150, 223124 or 223145	US1040, 1S2473 or 1S2076TD
Q101	22240008	μ PC-1290C			
Q107	222502	NJM4558DX	D401, D402, D404-D406	223163 or 223155	1SS133 or 1SS138
Q109, Q111	222465 or 222921	NJM4558D or BA4558D	D601	2239553 or 2243193	RD8.2EB3 or (G/W/Q) MTZ8.2C
Q201	222999	CX-20187	D701	223150,	US1040,
Q301	222652	M5218L	D704	223124 or 223145	1S2473 or 1S2076TD
Q303, Q304	222623	IR2E02			
Q403	222918	BA6251	D703	223163 or 223155	1SS133 or 1SS138
Q405	222465 or 222921	NJM4558D or BA4558D	D901-D904	223894	1N4002F
Q701	222955	LM6405L-1994	D905, D906	223163 or 223155	1SS133 or 1SS138
Q708	222775	BA6229	D907	2239472 or 2243152	RD5.6EB2 or MTZ5.6B
	Transistors		D908, D909	223163 or 223155	1SS133 or 1SS138
Q113, Q114	2212303 or 2211944	2SK381C or (G/W/Q) 2SK246Y			
Q203, Q204, Q401, Q402	2212794 or 2212795	2SD1468R or 2SD1468S			
Q407	2211455 or 2212495	2SA1015GR or JA101Q			
Q408	2201593 or 2201594	2SD1189P or 2SD1189Q			
Q409	2211255 or 2210746	2SC1815GR or 2SC945AP			
Q410, Q411	2211544	2SC1959Y			
Q412-Q413	221281	DTC114YS			
Q601	2211255 or 2210746	2SC1815GR or 2SC945AP			
Q602	2212600	DTA124ES			
Q603	221281	DTC114YS (G/W/Q)			
Q703, Q704	2211455 or 2212495	2SA1015GR or JA101Q			
Q705, Q706	2212855, 2212853, 2212852, 2212846 or 2212845	2SB1068U, 2SB1068K, 2SB1068L, 2SB598F or 2SB598E			
Q707	221282	DTC144ES			
Q709, Q710	2211255 or 2210746	2SC1815GR or 2SC945AP			
Q711-Q713	2213090	DTA114YS			
Q901	2201385	2SD330E			
Q902, Q904	2211255 or 2210746	2SC1815GR or 2SC945AP			
Q905	2201275 or 2201276	2SB772Q or 2SB772P			
Q906	2211455 or 2212495	2SA1015GR or JA101Q			
Q907	2212303 or 2211944	2SK381C or 2SK246Y			
Q908, Q909	2211455 or 2212495	2SA1015GR or JA101Q			
	Diodes				
D101-D104	223163 or 223155	1SS133 or 1SS138			
D105-D106	223150, 223124 or 223145	US1040, (G/W/Q) 1S2473 or 1S2076TD			
				Coils	
			L201, L202	233313	NMC6048
			L203, L204	233353	NMC2058
			L401, L402	24606072, 231085 or 231040	NCH1010, NCH2133 or NCH2080
			L403, L404	233314	NCH2097
			L405	231063	NLO2037
			L406	231077 or 231025	NCH2125 or NCH1064
				Capacitors	
			C103, C104	354721019	100 μ F, 6.3V, Elect.
			C111, C112	354780479	4.7 μ F, 50V, Elect.
			C123, C124	354741009	10 μ F, 16V, Elect.
			C127, C128	354780109	1 μ F, 50V, Elect.
			C201, C202	352980226	2.2 μ F, 50V, NP
			C203, C204	352950476	4.7 μ F, 25V, NP
			C225-C228	354780479	4.7 μ F, 50V, Elect.
			C229	352980226	2.2 μ F, 50V, NP
			C231, C232	352980226	2.2 μ F, 50V, NP
			C321, C322	354780479	4.7 μ F, 50V, Elect.
			C323, C324	354780109	1 μ F, 50V, Elect.
			C401, C402	354742209	22 μ F, 16V, Elect.
			C411, C412	354784799	0.47 μ F, 50V, Elect.
			C413, C414	354780479	4.7 μ F, 50V, Elect.
			C451	354744709	47 μ F, 16V, Elect.
			C452	354744709	47 μ F, 16V, Elect.
			C455	370131234	0.12 μ F, 100V, APS.
			C478	354742209	22 μ F, 16V, Elect.
			C479	354784799	0.47 μ F, 50V, Elect.
			C601, C603	354780109	1 μ F, 50V, Elect.
			C604, C605	354741009	10 μ F, 16V, Elect.
			C700	354744709	47 μ F, 16V, Elect.
			C701	354780109	1 μ F, 50V, Elect.
			C702	354781099	0.1 μ F, 50V, Elect.
			C706	352942206	22 μ F, 16V, NP
			C709	354724719	470 μ F, 6.3V, Elect.
			C903	354746829	6800 μ F, 16V, Elect.
			C904	354744729	4700 μ F, 16V, Elect.
			C907	354781099	0.1 μ F, 50V, Elect.
			C908	354741009	10 μ F, 16V, Elect.
			C909, C910	354721019	100 μ F, 6.3V, Elect.
			C911	354724719	470 μ F, 6.3V, Elect.

C912	354780479	4.7μF, 50V, Elect.
C913, C914	354742209	22μF, 16V, Elect.
C915	354780109	1μF, 50V, Elect.
C917-C918	354744709	47μF, 16V, Elect.
Resistors		
R115, R116	5210064	N06HR10kB, Semi-fixed
R133, R134	5104203	N09RGL50kA, Variable
R139, R140	5104203	N09RGL50kA, Variable
R401, R402	5215045	N08HR10kBC, Semi-fixed
R431	441521014	100Ω, 1/2W, Oxidefilm
R471, R472	5215025	N08HR200kBC, Semi-fixed
R701-R713	49163392413	3.9kΩ X 13, 1/10W, Network
R714-R721	49163392408	3.9kΩ X 8, 1/10W, Network
R722	5215003	N08HR20kBC, Semi-fixed
R730	441723904	39Ω, 1/2W, Oxidefilm
R731	441622204	22Ω, 1W, Oxidefilm
R901, R902	442520104	1Ω, 1/2W, Oxidefilm
R906	442522704	27Ω, 1/2W, Oxidefilm
Plugs		
P101	25055136	NPLG-6P120
P401	25055132	NPLG-2P116
P704	25055185	NPLG-4P169
P710	25055141	NPLG-11P125
Terminal		
P103	25045217	NPJ-4PDBL95, Input/output
P105	25045134	HLJ4337-01-010, Mic.
P107	25050064	NSCT-5P18, DIN (G/W/Q)
Socket		
	25050272	NSCT-8P100, Meter
	25050270	NSCT-6P98, Accu VR.
	25050273	NSCT-9P101
	25050270	NSCT-6P98, DOL B/C
Miscellaneous		
	27160151	RAD54, Radiator(Q905)
	27160150	RAD53, Radiator(Q901)
	82143006	3P+6FN, Screw
	27141121	Bracket(SW)

VAAF-2949-1

CIRCUIT NO.	PART NO.	DESCRIPTION
	IC	
Q103	22240020	NJM2068S-D
	Transistors	
Q105, Q106	2211255 or 2210746	2SC1815GR or 2SC945AP
	Plug	
Q109	25055324	NPLG-10P307

VAETC-2950-1

CIRCUIT NO.	PART NO.	DESCRIPTION
	ICs	
Q501	222736	NJM4558S
Q503	222695, 222681 or 22240040	LA6324, IR3702 or NJM2902N
	Diodes	
Q501-D506	223163 or 223155	1SS133 or 1SS138

CIRCUIT NO.	PART NO.	DESCRIPTION
	Capacitors	
C504	354781099	0.1μF, 50V, Elect.
C505	354780109	1μF, 50V, Elect.
C506	354741009	10μF, 16V, Elect.

CIRCUIT NO.	PART NO.	DESCRIPTION
	Plug	
P501	25055324	NPLG-10P307

NAPS-2951-1

CIRCUIT NO.	PART NO.	DESCRIPTION
△ C901	3500065A	0.01μF, 400V, AC, Capacitor IS
△ S901	25035559	NPS-111-L521P, Power

NAAR-2952-1

CIRCUIT NO.	PART NO.	DESCRIPTION
P301	25045139	HLJ0540-01-010, Headphone

NAAR-2954-1

CIRCUIT NO.	PART NO.	DESCRIPTION
P701	25050070	NSCT-7P20, Socket

NADIS-2943-4

CIRCUIT NO.	PART NO.	DESCRIPTION
	LEDs	
D301-D308	225228-J or 225228-K	SLV-31MC(J) or SLV-31MC(K)
D310-D314	225227	SLV-31VC
D661, D662	225227	SLV-31VC
D663-D665,	225228-J or 225228-K	SLV-31MC(J) or SLV-31MC(K)

△ PL901	Lamp 210090	150mA, 14V, Lamp
---------	-----------------------	------------------

R481	Resistor 6111002	5kBSZ, Variable
------	----------------------------	-----------------

S601, S602	Switches 25035523	NPS-122L485, Push
S712,		
S714-S720	25035548	NPS-111-S510, Push
S724, S725	25035523	NPS-122L485, Push

P704A	Socket 2000665	NSAS-8P621
-------	--------------------------	------------

	Holder 27190523A	Holder(LED-25)
--	----------------------------	----------------

NAETC-2955-1

CIRCUIT NO.	PART NO.	DESCRIPTION
	IC	
Q720	222558 or 222470	DN6838 or DN838K
	Spacer	
	27190173	Holder(for DN6838)
	27190251	Spacer(for DN838K)

NOTE: THE COMPONENTS IDENTIFIED BY MARK △ ARE CRITICAL FOR RISK OF FIRE AND ELECTRIC SHOCK. REPLACE ONLY WITH PARTS NUMBER SPECIFIED.

NOTE: [G]: Only 220V model
[W]: Only Worldwide model
[Q]: Only 240V model

SCHEMATIC DIAGRAM

A B C D E F G

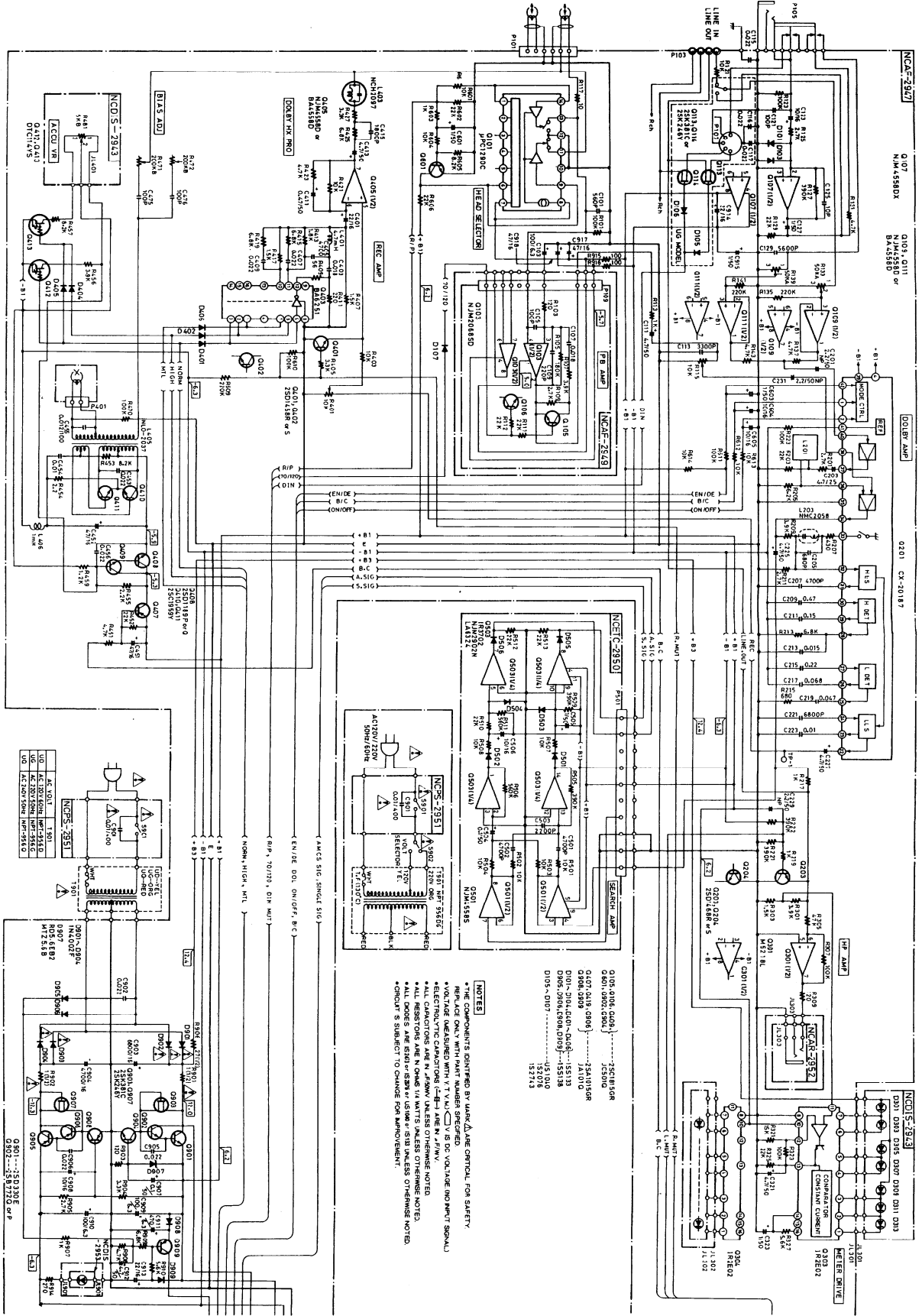

- NOTES**
- * COMPONENTS OBTAINED BY USER ARE CONTROL FOR SAFETY.
 - ** RES. LOC. ONLY. PART NUMBER SPECIFIED.
 - *** VOLTAGE MEASURED WITH "T.V.A. C.V." IS DC VOLTAGE (NO INPUT SIGNAL).
 - **** ELECTROLYTIC CAPACITORS (E-C) ARE IN μ F/V.V.
 - ***** ALL CAPACITORS ARE IN μ F/V.V. UNLESS OTHERWISE NOTED.
 - ***** ALL RESISTORS ARE IN Ω , K , M UNLESS OTHERWISE NOTED.
 - ***** CIRCUIT'S SUBJECT TO CHANGE FOR IMPROVEMENT.

ONKYO CORPORATION

TAPE MECHANISM-EXPLODED VIEW

