

ONKYO SERVICE MANUAL

STEREO CASSETTE TAPE DECK MODEL TA-2140

Black models

UDN, UDC, UD	120V AC, 60Hz
UG	220V AC, 50Hz
UW	120 or 220V AC, 50/60Hz
UQA, UQB	240V AC, 50Hz

SAFETY-RELATED COMPONENT WARNING!!

COMPONENTS IDENTIFIED BY MARK Δ ON THE SCHEMATIC DIAGRAM AND IN THE PARTS LIST ARE CRITICAL FOR RISK OF FIRE AND ELECTRIC SHOCK. REPLACE THESE COMPONENTS WITH ONKYO PARTS WHOSE PARTS NUMBERS APPEAR AS SHOWN IN THIS MANUAL.

MAKE LEAKAGE-CURRENT OR RESISTANCE MEASUREMENTS TO DETERMINE THAT EXPOSED PARTS ARE ACCEPTABLY INSULATED FROM THE SUPPLY CIRCUIT BEFORE RETURNING THE APPLIANCE TO THE CUSTOMER.

SPECIFICATIONS

Track System:	4-tracks, 2-channels
Erasing System:	AC erase
Tape Speed:	4.8 cm/sec (1-7/8 i.p.s.)
Wow and Flutter:	0.06% (WRMS)
Frequency Response:	20—15,000Hz (Normal) (30—14,000Hz \pm 3dB) 20—16,000Hz (High) (30—15,000Hz \pm 3dB) 20—17,000Hz (Metal) (30—16,000Hz \pm 3dB)
S/N Ratio:	Dolby NR off: 58dB (metal position tape) A noise reduction of 10dB above 5kHz and 5dB at 1kHz is possible with Dolby B NR. A noise reduction of 20dB at 5kHz is possible with Dolby C NR.
Input Jacks:	Microphone jacks: 2 Input sensitivity: 0.6mV/600 ohms Input impedance: 2.7 kohms Line IN: 2 Input sensitivity: 60mV Input impedance: 50 kohms
Outputs:	Line OUT: 2 Standard output level: 500mV (0dB) Optimum load impedance: over 50 kohms
Motors:	DC servo motor x 1; DC motor x 1
Heads:	REC/PB: Special Hard Permalloy x 1; Erase head: Ferrite x 1
Power Supply:	AC 120V, 60Hz
Power Consumption:	20 watts
Dimensions:	435(W) x 112(H) x 262(D)mm (17-1/8" x 4-3/8" x 10-3/8")



Weight: 4.1 kg. (9.1 lbs.)

Specifications and external appearance are subject to change without notice because of product improvements.

SERVICE PROCEDURES

1. Replacing the lamp

This unit used the lamp listed below.

Circuit No.	Parts No.	Description
PL901	210090	PL14V 150mA

Caution: Before replacing the lamp. Be sure to unplug the power supply cable.

2. Instruction resistance measurement

Connect the insulating-resistance tester between the plug of power supply cord and chassis.

Specifications; 500V more than 10MΩ

3. Replacement of power supply cord

There are two power supply cord outlets on the strainrelief. Insert them in prescribed direction to ensure safety. AS-UC-3 (UD<120V> model) should be inserted lengthwise and other types of cords should be inserted horizontally.

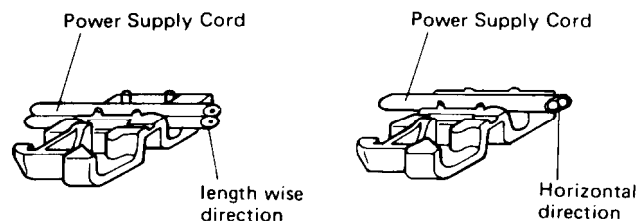

4. Method for removing BOTTOM BOARD (refer to exploded view of chassis)

1. Remove top cover.
2. Remove front panel.
3. Remove the 2 mounting screws of the main PC board (NAAF-2947-1).
4. Remove the 2 holders from the PC board.
5. Remove the 1 fastening screw of the Power Switch PC board (NAPS-2951-1).
6. Remove the holder from the PC board.
7. Remove the 4 fastening screws of the back panel and bottom board.
8. Remove the 3 fastening screws of the front bracket and bottom board.
9. Remove the ground terminal.
10. Remove the bottom board by taking from the lower direction.

5. Mechanism operation

This mechanism consists of a capstan motor, reel motor, and solenoid, with the power assist method by means of the capstan motor. In the operation, there are 3 conditions: STOP, PLAY, and CUE/REV. When the position is triggered by the solenoid, by means of intermittent rotation of the gear from the flywheel, as shown in Fig. 1, cyclic shifting is done.

To go from STOP to PLAY, if the solenoid is pulled in for 30ms, after about 150ms there is a shift to the PLAY condition. From this condition, if the solenoid is again pulled in, in that interval the condition shifts to CUE/REV. However, to suppress heat generation in the solenoid, the supply voltage must be reduced. If the power to the solenoid is cut off, the head lowers, and the condition goes to STOP. In order to have a cyclic operation as stated above, and to know the existing condition, a play switch is provided, and this switch is ON for PLAY and OFF for STOP (CUE/REV) is indefinite. When power is turned ON, the mechanism makes use of an initializer.

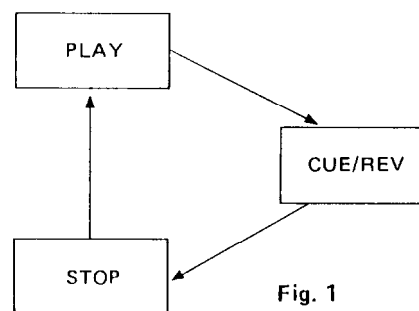
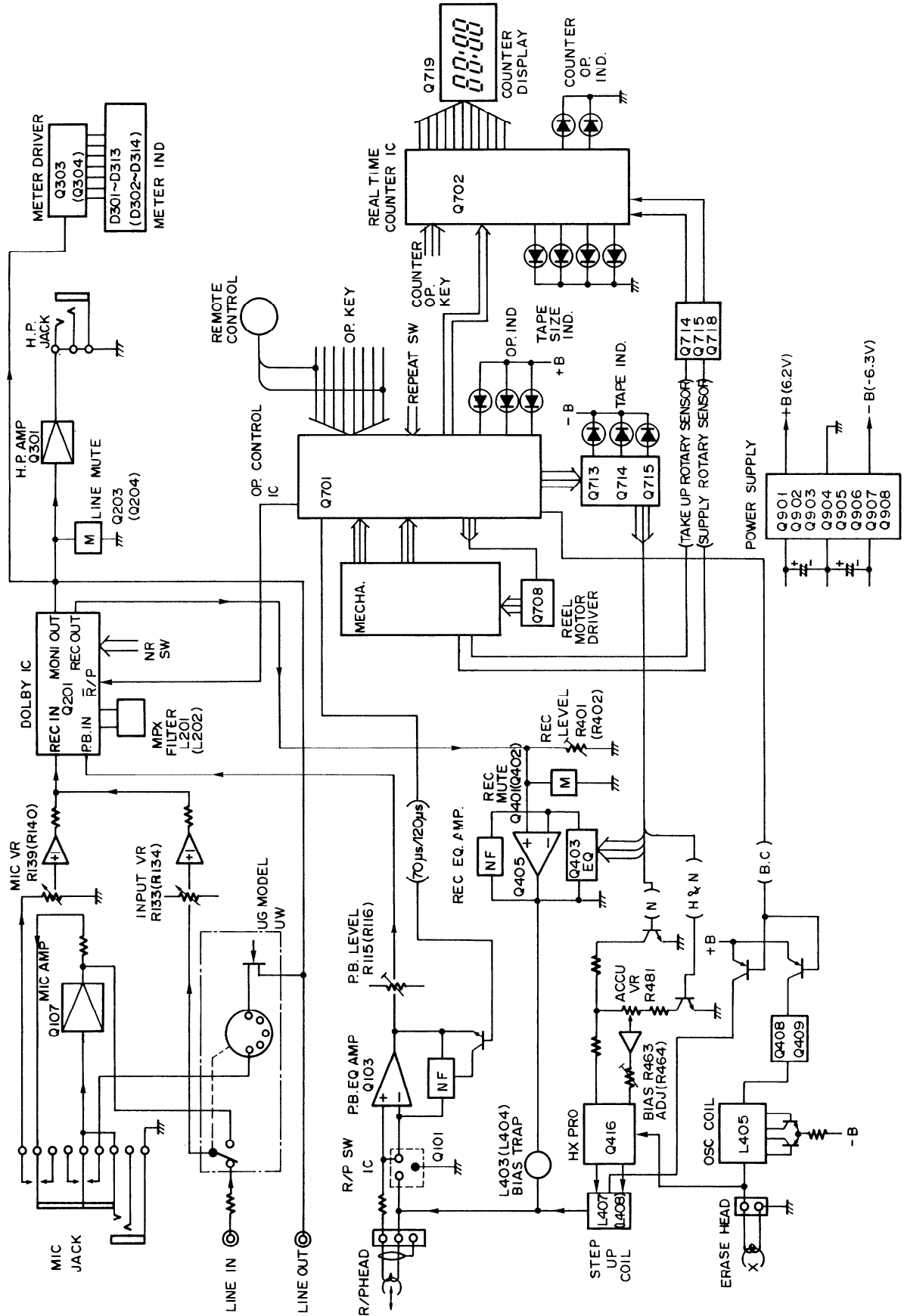

Fig. 1

BLOCK DIAGRAM



ADJUSTMENT PROCEDURES

PRECAUTIONS

- Before adjustment, clean the following parts with an alcohol moistend swab.
 - * record/playback head
 - * pinch roller
 - * erase head
 - * capstan
- Do not use magnetized screwdriver for adjustments.
- Demagnetize record/playback head with a head demagnetizer.

TEST EQUIPMENT/TOOLS REQUIRED:

- Audio oscillator
- Digital frequency counter

- Oscilloscope
- Attenuator
- AC voltmeter
- Non-magnetic screw driver
- Blank tapes (completely erased)
 - NORMAL NEW UD90
 - HIGH NEW XL-II90
 - METAL NEW MX60
- Test tapes
 - VTT-658 : 10 KHz, -15dB
 - MTT-111 : 3 kHz, -10dB
 - MTT-150 : Dolby level calibration
400Hz, tone 200nWb/m

Item	Connection of instrument	Line input	Test tape	Mode	Output indicator	Adjustment point	Adjust	Remarks
1	Tape speed		MTT-111	PB	Frequency counter	Semi-fixed on the motor	3,010 to 3,020Hz	
2	Head azimuth		VTT-658	PB	AC voltmeter	Head azimuth screw	Maximum and same phase at channels L and R	
3	Playback level		MTT-150	PB	AC voltmeter	R-115(Ch.L) R-116(Ch.R)	245mV	
4	Bias frequency		METAL TAPE	REC	Frequency counter	L-405	85kHz	
5	HX-PRO		METAL TAPE	REC	AC voltmeter	L-407(Ch.L) L-408(Ch.R)	Maximum	
6	Bias current	1kHz, -20dB and 12kHz, -20dB	NEW XL-II90	REC/PB	AC voltmeter	R-463(Ch.L) R-464(Ch.R)	Same level at REC/PB	Input VR maximum
7	Record level	Fig-1	1kHz	REC PAUSE	AC voltmeter	Attenuator of AF OSC output	350mV	Input VR maximum
				REC/PB	AC voltmeter	R-401(Ch.L) R-402(Ch.R)	Same level at REC/PB	
8	Clock				Frequency counter	R-722	160 to 170kHz	

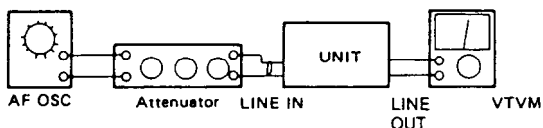
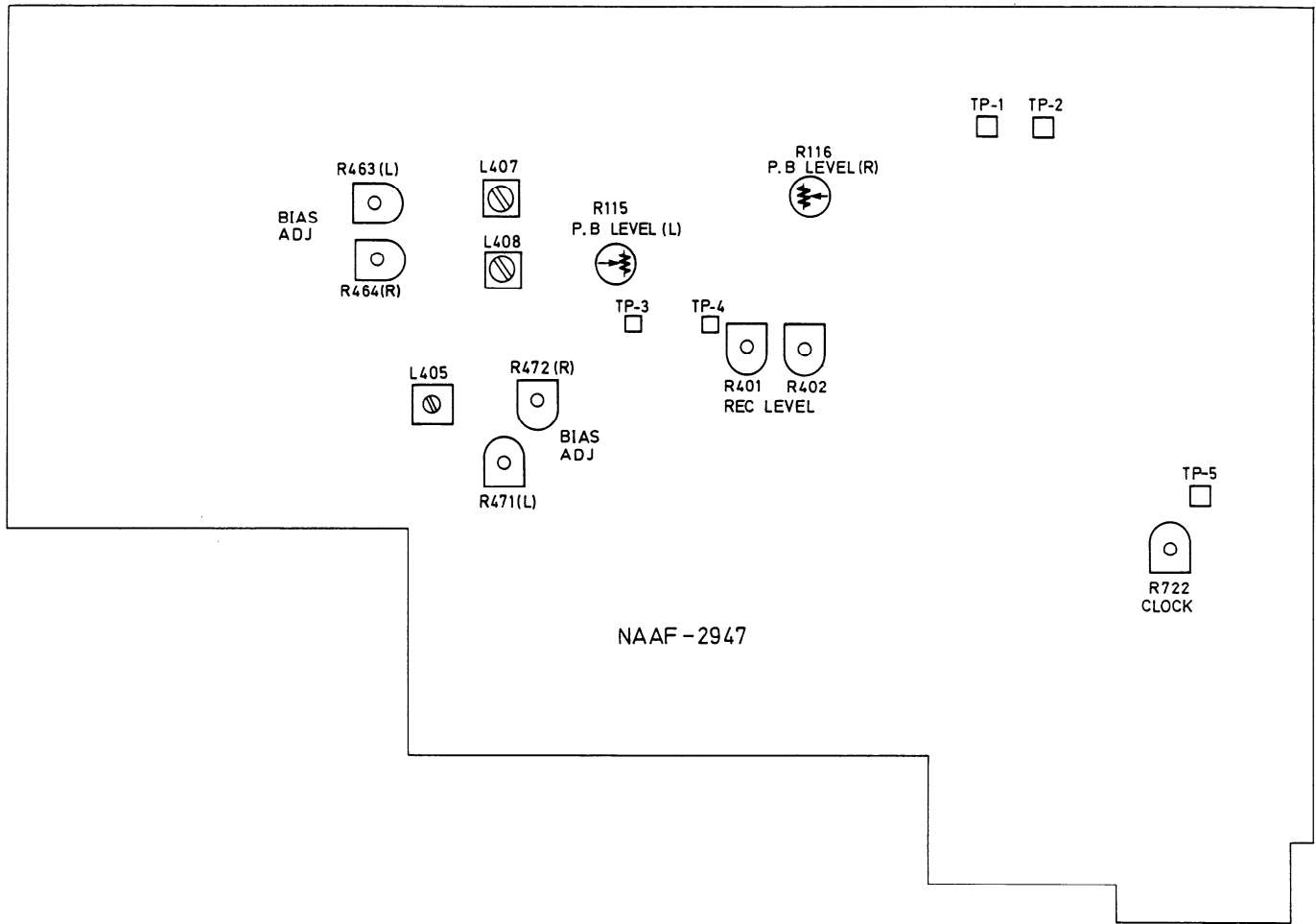
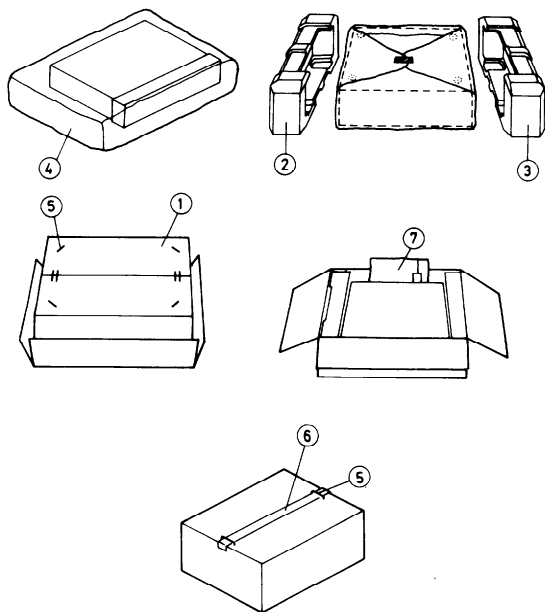

fig-1



PACKING VIEW



NOTE
 (N) : Only U.S.A. Model
 (W) : Only 120/220V Model
 (G) : Only 220V Model

D Model

REF NO.	PART NO.	DESCRIPTION
1	29051487	Master carton box
2	29090987	Pad(L)
3	29090988	Pad(R)
4	29100037A	650X500 Poly bag
5	282301	Sealing hook
6	260012	Damplon tape
7	Accessory bag ass'y	
	29341131	Instruction manual
	2010095	Connection cable
	29365019	Waranty card(N)
	29358002E	Service station list(N)
	29100006A	350X250 Poly bag

G/W Model

REF NO.	PART NO.	DESCRIPTION
1	29051487	Master carton box
2	29090987	Pad(L)
3	29090988	Pad(R)
4	29100037A	650X500 Poly bag
5	282301	Sealing hook
6	260012	Damplon tape
7	Accessory bag ass'y	
	29341132	Instruction manual
	29341164	Instruction manual I(G)
	2010095	Connection cable
	25055018	Conversion plug (CV-K-2)(W)
	29100006A	350X250 Poly bag

CHASSIS EXPLODED VIEW PART LIST

REF.NO.	PART NO.	DESCRIPTION	REF.NO.	PART NO.	DESCRIPTION
1	27110347	FRONT BRACKET AS	P101	△ 253099C	AS-UC-3, POWER SUPPLY
1-1	28194266	DECORATION PLATE (M)			CORD (D)
1-2	28322938	KNOB(SLIDE)AS		△ 253129A	AS-CEE, POWER SUPPLY
3	27100122	BOTTOM BOARD		△ 253118	CORD (G/W)
4	27141119	BRACKET (PC)		△ 25065123	AS-SAA, POWER SUPPLY
5	27273069A	JOINT (POW)	S901		CORD (Q)
6	28133178A	BACK PLATE			NSS-1258P, VOLTAGE
7	28130244A	INDICATOR PLATE			SELECTOR (W)
8	27190520	HOLDER	Z1	244104	NDM-96, TAPE MECHANISM
9	27190521	HOLDER (L.E.D.-5)			ASS'Y
10	27120965	BACK PANEL (D)	U1	1N007547-1	NAAF-2947-1, MAIN PC BOARD
	27120966	BACK PANEL (G)			ASS'Y (D)
	27120967	BACK PANEL (W)			NAAF-2947-1A, MAIN PC BOARD
	27121017	BACK PANEL (Q)			ASS'Y (G/W/Q)
11	△ 27300750	STRAINRELIEF	U2	1N007548-1	BOARD ASS'Y
13	86414010	FLANGE NUT FWN4X10FN			NADIS-2948-1, DISPLAY PC
14	28322940A	KNOB (SKIP)	U3	1N007549-1	NADIS-2949-1, PLAY BACK
15	28400312	CASSETTE LID			AMPLIFIER PC BOARD ASS'Y
16	28400313A	WINDOW	U4	1N007550-1	NAETC-2950-1, SEARCH AMP PC
17	27180272	SPRING (CA)			BOARD ASS'Y
18	28400282	DAMPER	U5	△ 1N007551-1	NAPS-2951-1, POWER SWITCH PC
19	27180334	SPRING			BOARD ASS'Y
20	28184346-1	TOP COVER	U6	1N007552-1	NAAR-2952-1, HEAD PHONE
21	1N006121	FRONT PANEL			TERMINAL PC BOARD ASS'Y
24	28322946	KNOB (BAL)	U7	1N007553-1	NADIS-2953-1, HX PRO INDICATOR
25	28322948	KNOB (VOL)			PC BOARD ASS'Y
26	28322795	KNOB (POW)	U8	1N007554-1	NAAR-2954-1, REMOTE CONTROL
27	28322970	KNOB AS (EJ)			PC BOARD ASS'Y
30	27190524	HOLDER	U9	1N007543-2	NADIS-2943-2
31	28191396	CLEAR PLATE	U10	1N007544-2	NADIS-2944-2
33	27175028	LEG			
34	834430088	TAP-TIGHT SCREW 3TTS+8BBC			
35	834430108	TAP-TIGHT SCREW 3TTS+10BB			
36	831130088	TAP-TIGHT SCREW 3TTW+8B			
37	833430080	TAP-TIGHT SCREW 3TTP+8PBC			
38	830440109	TAP-TIGHT SCREW 4TTC+10CB			
39	82142604	PAN-HEAD SCREW 2.6P+4F BC			
40	834230108	TAP-TIGHT SCREW 3TTS+10BN			
T901	△ 2300203	NPT-956D, POWER			
	△ 2300205	TRANSFORMER (D)			
	△ 2300204	NPT-956G, POWER			
	△ 2300204	TRANSFORMER (G)			
	△ 2300241	NPT-956DC, POWER			
	△ 2300241	TRANSFORMER (W)			
		NPT-956Q, POWER			
		TRANSFORMER (Q)			

NOTE (D): Only 120V model
 (G): Only 220V model
 (W): Only 120V/220V model
 (Q): Only 240V model
 (B): Black model

NOTE: THE COMPONENTS IDENTIFIED BY MARK △ ARE CRITICAL FOR RISK OF FIRE AND ELECTRIC SHOCK. REPLACE ONLY WITH PART NUMBER SPECIFIED.

CHASSIS-EXPLODED VIEW

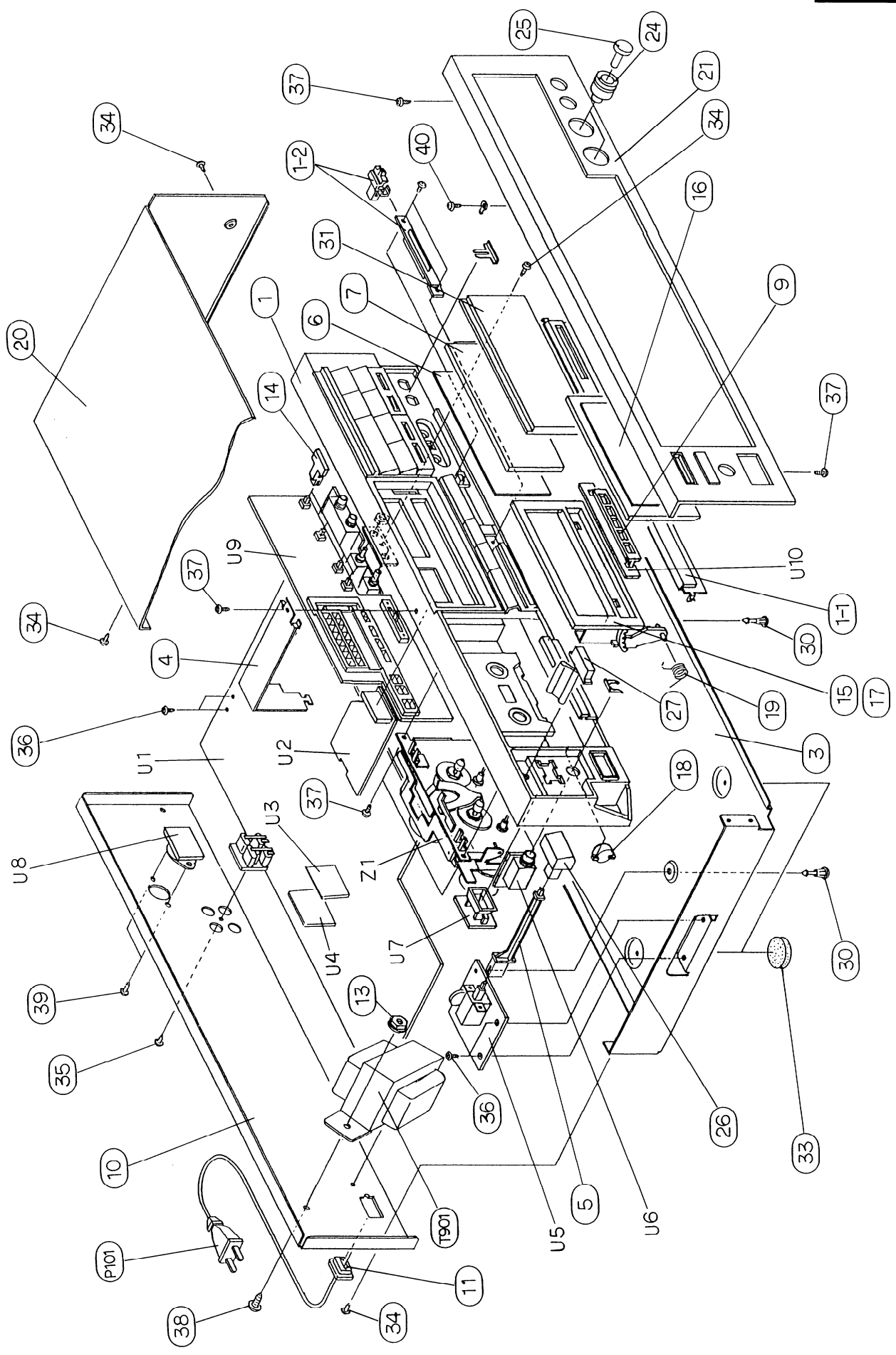

MICROCOMPUTER (LM6405L-1994)

In the microcomputer, the operating voltage is high with the NMOS type LM6405L using $V_{DD} = 6V$. The clock uses a condenser/resistor oscillator and is designed for a frequency of 170KHz. (Frequency measurement can be made by connection through a $100K\Omega \sim 330K\Omega$ to pin No. 1.)

Port No.	Name	Function
1	XTAL	Connected to resistor of oscillator for clock use
2	$\overline{\text{BIAS OUT}}$	Output port for turning bias oscillator ON/OFF: Oscillation with 0 level
3	$\overline{\text{LINE MUTE}}$	Output port for line muting: Muting with 0 level
4	$\overline{\text{REC. MUTE}}$	Output port for recording muting: Muting with 0 level
5	$\overline{\text{CASSETTE IN}}$	Input for cassette loading detection: Cassette loading with 0 level
6	ROTATION SENSOR	Pulse input rotation detection
7	$\overline{\text{RESET}}$	System reset for microcomputer use
8	CrO ₂	Input for automatic detection of chrome tape: Chrome use hole detection with 1 level
9	METAL	Input for automatic detection of metal tape: Metal use hole detection with 1 level
10	$\overline{\text{PLAY SWITCH}}$	Input for PLAY position detection: PLAY position with 0 level
11	REC. INH	Lug detection input for recording prevention: Disable with 1 level
12	REEL FF	Output for reel motor rotation in fast forward direction: Rotation with 1 level
13	REEL REW	Output for reel motor rotation in rewind direction: Rotation with 1 level
14	O PLAY	Reel motor rotation selection: Slow with 1 Fast with 0
15	$\overline{\text{PLAY LED}}$	LED output for PLAY indication: Lights with 0
16	$\overline{\text{PAUSE LED}}$	LED output for PAUSE indication: Lights with 0
17	$\overline{\text{REC LED}}$	LED output for REC indication: Lights with 0
18	$\overline{\text{SOL. P-UP}}$	Output for solenoid pull in: Pull in with 0
19	$\overline{\text{SOL}}$	Output for solenoid pull in hold (low power): Pull in hold with 0
20	TEST	Input for microcomputer chip inspection (Normally connected to V_{SS})
21	V_{SS}	Ground terminal
22	$70 \mu s / 120 \mu s$	For input to pins 8, 9, output for play back equalizer selection
23	$\overline{\text{NORMAL}}$	For input to pins 8, 9, output for record equalizer selection (NORMAL)
24	HIGH	For input to pins 8, 9, output for record equalizer selection (HIGH)
25	METAL	For input to pins 8, 9, output for record equalizer selection (METAL)
26	SINGLE SIG.	Input for recording signal detection for single repeat when in low speed
27	AMCS SIG.	Input for recording signal detection for AMCS use when in high speed
28	$\overline{\text{REPEAT OFF/ON}}$	Input for repeat operation ON/OFF: Operates with 0
29	$\overline{\text{SINGLE/FULL}}$	Selection of SINGLE/FULL operation: Full repeat with 0

Port No.	Name	Function
30	$\overline{\text{P OFF}}$	Input for power off detection: Off with 0
31	$\overline{\text{TIMER REC}}$	Input for timer recording ON/OFF: Operates with 0
32	$\overline{\text{TIMER PLAY}}$	Input for timer play back ON/OFF: Operates with 0
33	$\overline{\text{AMCS}}$	Key input to cause AMCS operation: Operation with 0
34	$\overline{\text{REW}}$	Key input to cause rewinding: Operation with 0
35	$\overline{\text{FF}}$	Key input to cause fast forward operation: Operation with 0
36	$\overline{\text{STOP}}$	Key input to cause stop operation: Operation with 0
37	$\overline{\text{AUTO SPACE}}$	Key input to cause auto space operation: Operation with 0
38	$\overline{\text{PAUSE}}$	Key input to cause pause or recording pause: Operation with 0
39	$\overline{\text{REC}}$	Key input pushed together with PLAY key to cause recording: Operation with 0
40	$\overline{\text{PLAY}}$	Key input for play back or recording: Operation with 0
41	V _{DD}	Power source terminal
42	E. XTAL	Connects to resistor and condenser of oscillator for clock

NOTE 0: Low level
1: High level

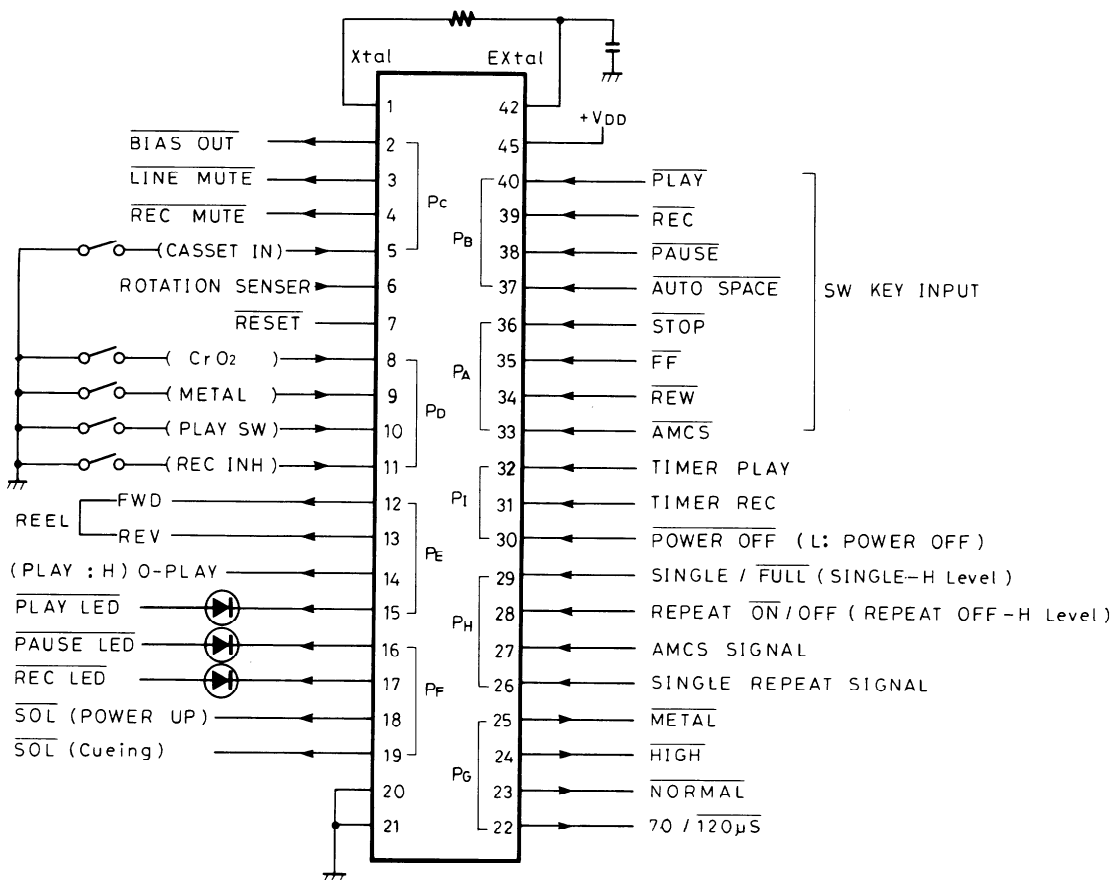

HD614120S-A27 (Counter)

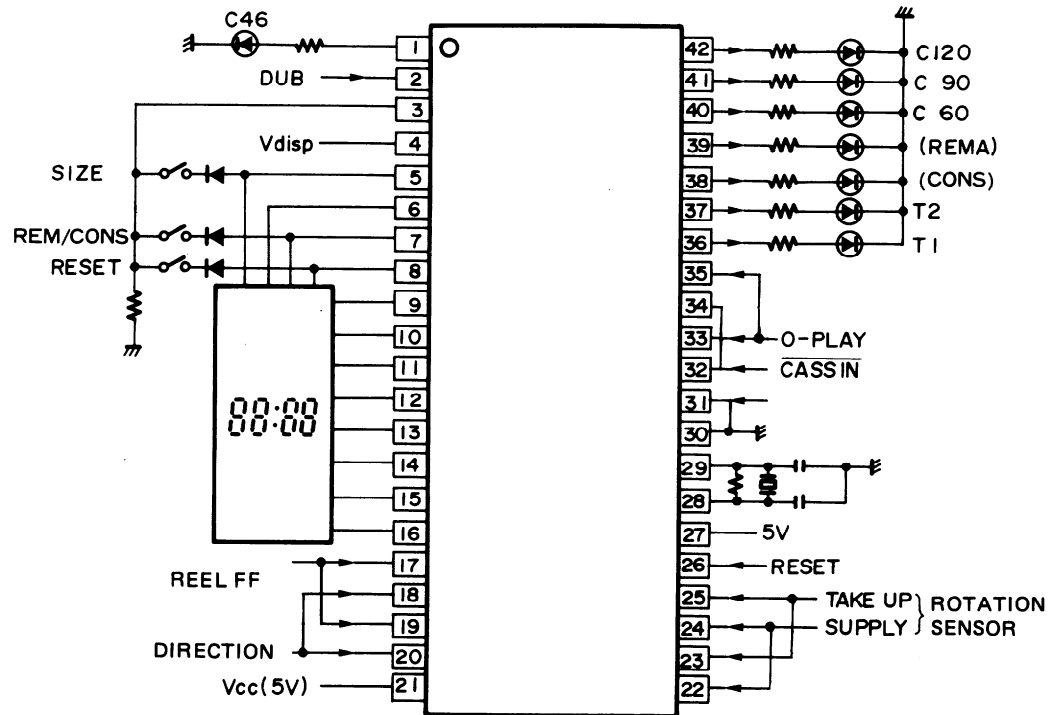

CX20187 (DOLBY N.R)

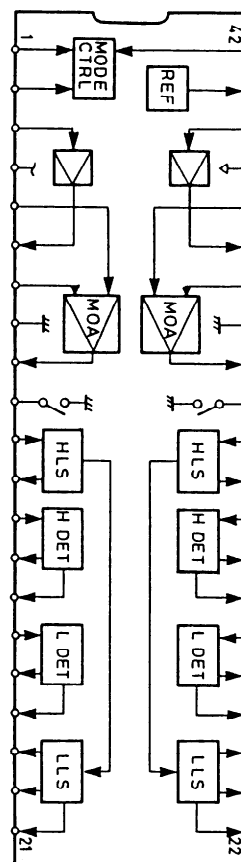
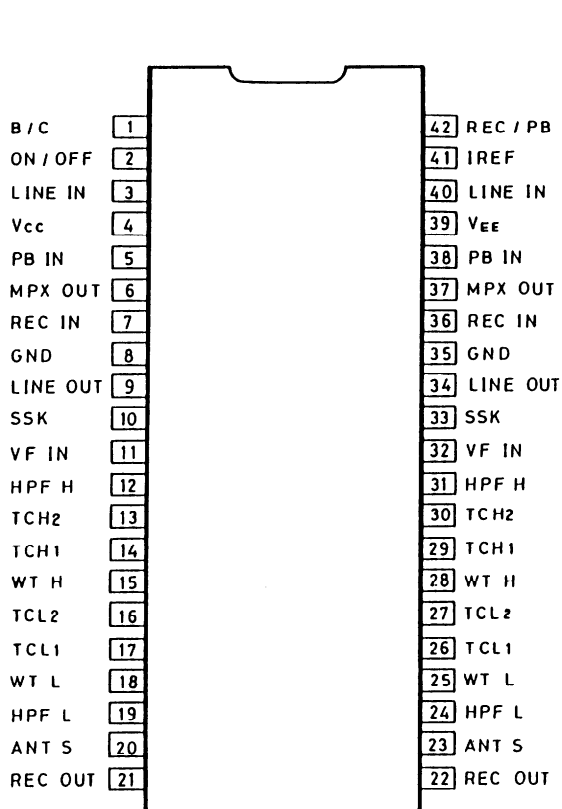

μPC1297CA (DOLBY HX PRO SYSTEM)

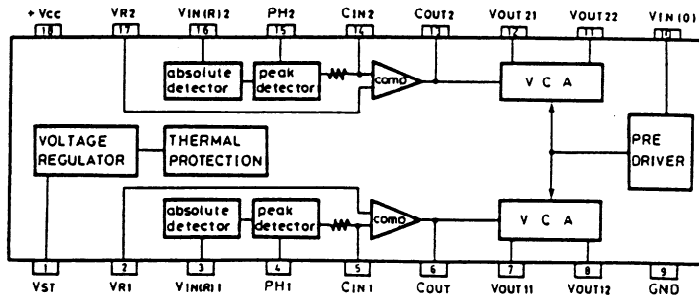

When the HX PRO is operation, by means of the recording signal coming from the recording head, a modulating oscillator voltage is applied to the absolute value detection circuit, and by means of the recording signal level peak detection value, the bias current is instantaneously controlled. At such time, by means of the CR integrated circuit, the frequency characteristic is maintained.

μPC1290C

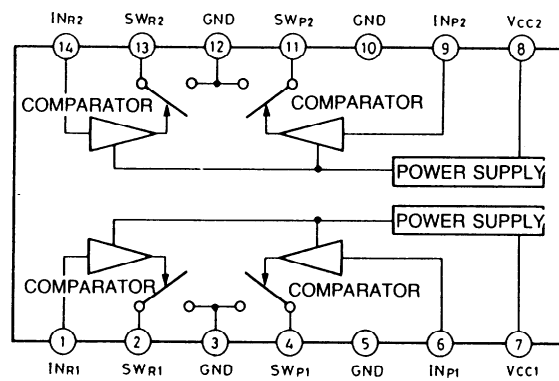

IR2E02 (LEVEL METER DRIVE)

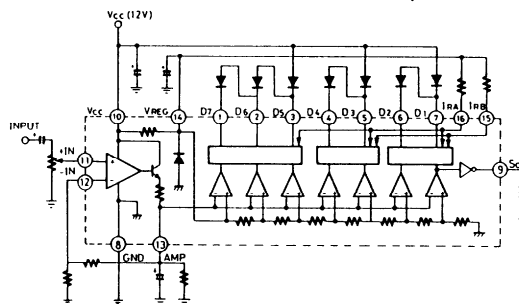

BA6251 (REC AMP. EQ. SW)

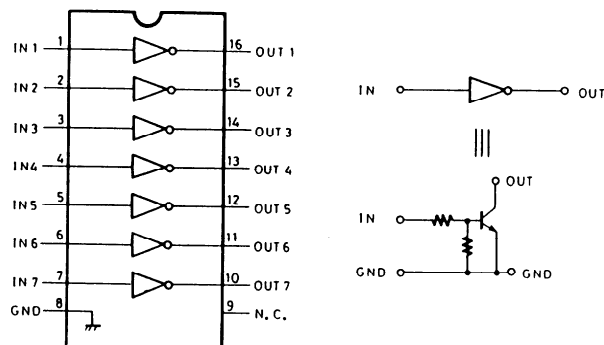

TAPE MECHANISM-PART LIST

REF NO.	PART NO.	DESCRIPTION	REF NO.	PART NO.	DESCRIPTION
1	24611206	CHASSIS (A)	74	24611229	PLASTIC WASHER 1.6X3.5X.5
2	24606244	SOLENOID COIL	75	24611296	PLASTIC WASHER 2.1X4.0X.5
3	24611207	HOUSING AS (R)	76	24611230	NYLON WASHER 1.9X5X.5
4	24607048	SHIFT ARM AS	78	833120047	TAP-TIGHT SCREW M2X4
5	24604077	COLLAR (SHIFT ARM)	79	838120047	TAP-TIGHT SCREW M2X4
6	24605604	SPRING (SHIFT ARM)	80	833120057	TAP-TIGHT SCREW M2X5
7	24602370	GEAR AS (IDLER) (7)+(8)+(9) +(11)+(10)	81	833120087	TAP-TIGHT SCREW M2X8
8	24611208	WASHER (IDLER)	84	801369	FLAT SCREW M2.6X4
9	24602362	GEAR (IDLER)	85	82112604	PAN-HEAD SCREW 2.6P+4F
10	24611312	BE-SU (IDLER)	86	82152011	SCREW M2X11
11	24605605	SPRING (CLUTCH)	87	801370	SCREW/W.WASHER M2X10
12	24602363	GEAR (MOTOR)	88	801371	SEMS SCREW M2.6X4
14	24611210	GUIDE (CASSETTE)	90	24611231	SHIELD PLATE
15	24611211	GUIDE (CASSETTE) L	93	24603333	BRAKE LEVER (N)
16	24611212	GUIDE (CASSETTE) R	94	24607051	BRAKE ARM
17	24605606	SPRING (PACK)	95	24605616	SPRING (BRAKE)
18	24611213	WASHER (REEL)	97	24604080	COLLAR (SHIFT ARM)
19	24605607	SPRING (REEL)	103	24611233	PLASTIC WASHER 1.7X3.5X.5
20	24602364	REEL	104	24611234	PLASTIC WASHER 2.1X6.8X.4
21	24605617	SPRING (HEAD CHASSIS) F			
22	24611214	HEAD CHASSIS (A)			
23	24611215	HEAD BASE			
24	24605608	SPRING (HEAD)			
25	24605609	SPRING (REEL) C			
26	24602365	GEAR (PLAY)			
27	24607064	PL ARM			
28	24605610	SPRING (PL ARM)			
29	24602366	FLYWHEEL AS			
30	24604078	SPACER (CAPSTAN)			
31	24611216	HOLDER (MOTOR) A			
32	24602367	BELT (A)			
33	24602368	MOTOR PULLEY (A)			
34	24602369	PINCH ROLLER AS (R)			
35	24605611	SPRING (PINCH ROLLER) R			
36	24611217	PROTECTOR (SW)			
38	24611218	HOLDER (EJECT)			
39	24611219	STOPPER (CASSETTE)			
40	24611220	EJECTOR			
41	24605612	SPRING (EJECT) A			
42	24605613	SPRING (EJECT) B			
43	24607050	ARM (EJECT LOCK)			
44	24604079	COLLAR (LOCK ARM)			
45	24605614	SPRING (LOCK ARM)			
47	24611313	REFLECTOR			
48	24606275	P.C.BOARD			
49	24606276	PHOTO REFLECTOR RPS401			
52		3P WIRE			
53		3P WIRE			
54		11P WIRE			
55		6P WIRE			
56		2P WIRE			
60	24611227	CORD CLAMPER			
61	24611228	CORD CLAMPER			
62	24600051	R/P HEAD			
63	24600041	E HEAD			
64	24601200	CAPSTAN MOTOR AS ((33)+(64))			
65	24601201	REEL MOTOR AS ((12)+(63)+(90))			
66	24606245	LEAF SWITCH			
67	24606246	LEAF SWITCH			
69	801367	SCREW (A)			
70	801368	SCREW (B)			
73	8771224303	WASHER (L)			

PRINTED CIRCUIT BOARD-PARTS LIST

N AAF-2947-1

CIRCUIT NO.	PART NO.	DESCRIPTION	CIRCUIT NO.	PART NO.	DESCRIPTION
	Ics				
Q101	22240008	μPC-1290C	D107	223150,	US1040,
Q107	222502	NJM4558DX		223124 or	1S2473 or
Q109, Q111	222465 or	NJM4558D or		223145	1S2076TD
	222921	BA4558D	D401, D402,	223163 or	1SSI33 or
Q201	222999	CX-20187	D404-D406	223155	1SSI38
Q301	222652	M5218L	D601	2239553 or	RD8.2EB3 or (G)
Q303, Q304	222623	IR2E02		2243193	MTZ8.2C
Q403	222918	BA6251	D701, D702,	223150,	US1040,
Q405, Q415	222465 or	NJM4558D or	D704	223124 or	1S2473 or
	222921	BA4558D		223145	1S2076TD
Q417	222959	μPC-1297CA	D703	223163 or	1SSI33 or
Q701	222955	LM6405L-1994		223155	1SSI38
Q708	222775	BA6229	D901-D904	223891	RL152
	Transistors		D905, D906	223163 or	1SSI33 or
Q113, Q114	2212303 or	2SK381C or (G/W/Q)		223155	1SSI38
	2211944	2SK246Y	D907	2239472 or	RD5.6EB2 or
Q203, Q204,	2212794 or	2SD1468R or		2243152	MTZ5.6B
Q401, Q402	2212795	2SD1468S	D908, D909	223163 or	1SSI33 or
Q407	2211455 or	2SA1015GR or		223155	1SSI38
	2212495	JA101Q		Coils	
Q408	2201593 or	2SD1189P or	L201, L202	233313	NMC6048
	2201594	2SD1189Q	L203, L204	233353	NMC2058
Q409	2211255 or	2SC1815GR or	L401, L402	24606072,	NCH1010,
	2210746	2SC945AP		231085 or	NCH2133 or
Q410, Q411	2211544	2SC1959Y		231040	NCH2080
Q412-Q414	221281	DTC114YS	L403, L404	233314	NCH2097
Q419	2211455 or	2SA1015GR or	L405	231063	NLO2037
	2212495	JA101Q	L406	231077 or	NCH2125 or
Q601	2211255 or	2SC1815GR or		231025	NCH1064
	2210746	2SC945AP	L407, L408	231127	NCH4183
Q602	2212600	DTA124ES		Capacitors	
Q603	221281	DTC114YS (G/W/Q)	C103, C104	354721019	100μF, 6.3V, Elect.
Q703, Q704	2211455 or	2SA1015GR or	C111, C112	354780479	4.7μF, 50V, Elect.
	2212495	JA101Q	C123, C124	354741009	10μF, 16V, Elect.
Q705, Q706	2212855,	2SB1068U,	C127, C128	354780109	1μF, 50V, Elect.
	2212853,	2SB1068K,	C201, C202	352980226	2.2μF, 50V, NP
	2212852,	2SB1068L,	C203, C204	352950476	4.7μF, 25V, NP
	2212846 or	2SB598F or	C225-C228	354780479	4.7μF, 50V, Elect.
	2212845	2SB598E	C229	352980226	2.2μF, 50V, NP
Q707	221282	DTC144ES	C231, C232	352980226	2.2μF, 50V, NP
Q709, Q710	2211255 or	2SC1815GR or	C321, C322	354780479	4.7μF, 50V, Elect.
	2210746	2SC945AP	C323, C324	354780109	1μF, 50V, Elect.
Q711-Q713	2213090	DTA114YS	C401, C402	354742209	22μF, 16V, Elect.
Q714	2211255 or	2SC1815GR or	C411, C412	354784799	0.47μF, 50V, Elect.
	2210746	2SC945AP	C413, C414	354780479	4.7μF, 50V, Elect.
Q901	2201385	2SD330E	C451	354741009	10μF, 16V, Elect.
Q902, Q904	2211255 or	2SC1815GR or	C452	354744709	47μF, 16V, Elect.
	2210746	2SC945AP	C455	370131234	0.12μF, 100V, APS.
Q905	2201275 or	2SB772Q or	C469, C470	370131514	150PF, 100V, APS.
	2201276	2SB772P	C471-C473	354741009	10μF, 16V, Elect.
Q906	2211455 or	2SA1015GR or	C477	354721019	100μF, 6.3V, Elect.
	2212495	JA101Q	C479	354784799	0.47μF, 50V, Elect.
Q907	2212303 or	2SK381C or	C480	354742209	22μF, 16V, Elect.
	2211944	2SK246Y	C601, C603	354780109	1μF, 50V, Elect.
Q908, Q909	2211455 or	2SA1015GR or	C604, C605	354741009	10μF, 16V, Elect.
	2212495	JA101Q	C700	354744709	47μF, 16V, Elect.
	Diodes		C701	354780109	1μF, 50V, Elect.
D101-D104	223163 or	1SSI33 or	C702	354781099	0.1μF, 50V, Elect.
	223155	1SSI38	C706	352942206	22μF, 16V, NP
D105-D106	223150,	US1040, (G/W/Q)	C709	354724719	470μF, 6.3V, Elect.
	223124 or	1S2473 or	C903	354746829	6800μF, 16V, Elect.
	223145	1S2076TD	C904	354744729	4700μF, 16V, Elect.

CIRCUIT NO.	PART NO.	DESCRIPTION	CIRCUIT NO.	PART NO.	DESCRIPTION
C907	354781099	0.1 μ F, 50V, Elect.			
C908	354741009	10 μ F, 16V, Elect.			
C909, C910	354721019	100 μ F, 6.3V, Elect.			
C911	354724719	470 μ F, 6.3V, Elect.			
C912	354780479	4.7 μ F, 50V, Elect.			
C913, C914	354742209	22 μ F, 16V, Elect.			
C915	354780109	1 μ F, 50V, Elect.			
C916-C918	354744709	47 μ F, 16V, Elect.			
	Resistors				
R115, R116	5210064	N06HR10kB, Semi-fixed			
R133, R134	5104203	N09RGL50kA, Variable			
R139, R140	5104203	N09RGL50kA, Variable			
R401, R402	5215045	N08HR10kBC, Semi-fixed			
R431	441521014	100 Ω , 1/2W, Oxidefilm			
R463, R464	5215045	N08HR10kBC, Semi-fixed			
R701-R713	49163392413	3.9k Ω X13, 1/10W, Network			
R714-R721	49163392408	3.9k Ω X8, 1/10W, Network			
R722	5215003	N08HR20kBC, Semi-fixed			
\ R730	441723904	39 Ω , 1/2W, Oxidefilm			
\ R731	441622204	22 Ω , 1W, Oxidefilm			
\ R901, R902	442520104	1 Ω , 1/2W, Oxidefilm			
\ R906	442522704	27 Ω , 1/2W, Oxidefilm			
	Plugs				
P101	25055136	NPLG-6P120			
P401	25055132	NPLG-2P116			
P704	25055185	NPLG-4P169			
P710	25055141	NPLG-11P125			
P711	25055133	NPLG-3P117			
	Terminal				
P103	25045217	NPJ-4PDBL95, Input/output			
P105	25045134	HLJ4337-01-010, Mic.			
P107	25050064	NSCT-5P18, DIN (G/W/Q)			
	Socket				
	25050272	NSCT-8P100, Meter			
	25050270	NSCT-6P98, Accu VR.			
	25050273	NSCT-9P101			
	25050270	NSCT-6P98, DOL B/C			
	Miscellaneous				
	27160151	RAD54, Radiator(Q905)			
	27160150	RAD53, Radiator(Q901)			
	82143006	3P+6FN, Screw			
	27141121	Bracket(SW)			

N ADIS-2948-1

CIRCUIT NO.	PART NO.	DESCRIPTION
	Ics	
Q702	22240041	HD614120S-A27
Q715	222840692	4069UBP
	Transistoers	
Q716	221282	DTC-144ES
Q717	2212600	DTA-124ES
Q718	2211255 or 2210746	2SC1815GR or 2SC945AP
	Diodes	
D710-D712	223163 or 223155	1SS133 or 1SS138
	Capacitors	
C714	354741009	10 μ F, 16V, Elect.
C715	354744709	47 μ F, 16V, Elect.

NOTE (G): Only 220V model
(W): Only 120V/220V model
(Q): Only 240V model

NOTE: THE COMPONENTS IDENTIFIED BY MARK  ARE CRITICAL FOR RISK OF FIRE AND ELECTRIC SHOCK. REPLACE ONLY WITH PART NUMBER SPECIFIED.

PRINTED CIRCUIT BOARD PARTS LIST

NAETC-2950-1

CIRCUIT NO. PART NO. DESCRIPTION

Q501 222736 NJM4558S
 Q503 222695, LA6324,
 222681 or IR3702 or
 22240040 NJM2902N

Diodes

D501-D506 223163 or 1SS133 or
 223155 1SS138

Capacitors

C504 354781099 0.1 μ F, 50V, Elect.
 C505 354780109 1 μ F, 50V, Elect.
 C506 354741009 10 μ F, 16V, Elect.

Plug

P501 25055324 NPLG-10P307

N APS-2951-1

CIRCUIT NO. PART NO. DESCRIPTION

 C901 3500065A 0.01 μ F, 400V, AC, Capacitor IS
 S901 25035559 NPS-111-L521P, Power

NAAR-2952-1

CIRCUIT NO. PART NO. DESCRIPTION

P301 25045139 HLJ0540-01-010, Headphone

N ADIS-2953-1

CIRCUIT NO. PART NO. DESCRIPTION

D901 225228-J or SLV-31MC(J) or
 225228-K SLV-31MC(K)
 27190522 Holder(LED-1)

NAAR-2954-1

CIRCUIT NO. PART NO. DESCRIPTION

P701 25050070 NSCT-7P20, Socket

NADIS-2943-2

CIRCUIT NO. PART NO. DESCRIPTION

LEDs

D301-D308 225228-J or SLV-31MC(J) or
 225228-K SLV-31MC(K)
 D310-D314 225227 SLV-31VC
 D661, D662 225227 SLV-31VC
 D663-D665, 225228-J or SLV-31MC(J) or
 D751-D756 225228-K SLV-31MC(K)

Lamp

 PL901 210090 150mA, 14V, Lamp

Resistor

R481 6111002 5k Ω 5Z, Variable

Switches

S601, S602 25035523 NPS-122L485, Push
 S712-S723 25035548 NPS-111S510, Push
 S724, S725 25035523 NPS-122L485, Push

CIRCUIT NO. PART NO. DESCRIPTION

Socket
 P702A 2000665 NSAS-8P621
 P703A 2000603 NSAS-12P559

Holder

27190523A Holder(LED-25)

NADIS-2944-2

CIRCUIT NO. PART NO. DESCRIPTION

LED

D666, ~~D668~~ 225190 GL1PRI
 D667 225192 GLING1

Socket

P704A 2000516 NSAS-8P472

NOTE: THE COMPONENT IDENTIFIED BY MARK  ARE CRITICAL FOR RISK OF FIRE AND ELECTRIC SHOCK. REPLACE ONLY WITH PART NUMBER SPECIFIED.

ONKYO CORPORATION

International Division: No. 24 Mori Bldg., 23-5, Nishi Shimbashi 3-chome, Minato-ku,
 TOKYO 105, JAPAN Tel: 03-432-6987 Fax: 03-436-6979 TLX: 242-3551 ONKYO J

ONKYO U.S.A. CORPORATION

200 Williams Drive, Ramsey, N.J. 07446, U.S.A. Tel: 201-825-7950 Fax: 201-825-8150

SCHEMATIC DIAGRAM (CONTROL SECTION)

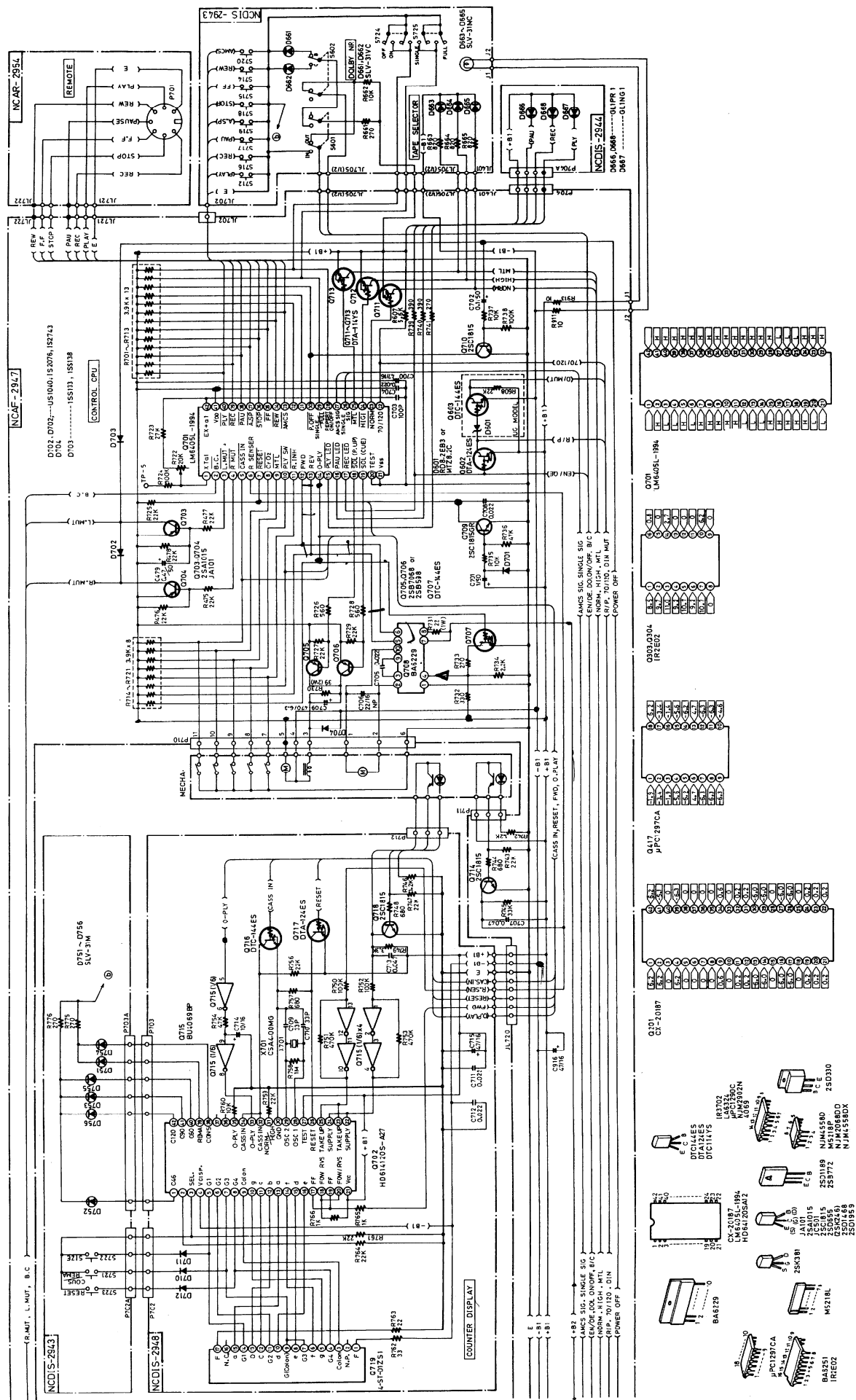

ONKYO CORPORATION

- ICs: NCDIS-2943, NCAAF-2947, NCAR-2954, NCDIS-2944
- Transistors: OT15, OT16, OT17, OT18, OT20
- Diodes: D01, D02, D03, D04, D05, D06, D07, D08, D09, D10, D11
- Resistors: R101, R102, R103, R104, R105, R106, R107, R108, R109, R110, R111, R112, R113, R114, R115, R116, R117, R118, R119, R120, R121, R122, R123, R124, R125, R126, R127, R128, R129, R130, R131, R132, R133, R134, R135, R136, R137, R138, R139, R140, R141, R142, R143, R144, R145, R146, R147, R148, R149, R150, R151, R152, R153, R154, R155, R156, R157, R158, R159, R160, R161, R162, R163, R164, R165, R166, R167, R168, R169, R170, R171, R172, R173, R174, R175, R176, R177, R178, R179, R180, R181, R182, R183, R184, R185, R186, R187, R188, R189, R190, R191, R192, R193, R194, R195, R196, R197, R198, R199, R200
- Capacitors: C101, C102, C103, C104, C105, C106, C107, C108, C109, C110, C111, C112, C113, C114, C115, C116, C117, C118, C119, C120, C121, C122, C123, C124, C125, C126, C127, C128, C129, C130, C131, C132, C133, C134, C135, C136, C137, C138, C139, C140, C141, C142, C143, C144, C145, C146, C147, C148, C149, C150, C151, C152, C153, C154, C155, C156, C157, C158, C159, C160, C161, C162, C163, C164, C165, C166, C167, C168, C169, C170, C171, C172, C173, C174, C175, C176, C177, C178, C179, C180, C181, C182, C183, C184, C185, C186, C187, C188, C189, C190, C191, C192, C193, C194, C195, C196, C197, C198, C199, C200
- Other: Counter Display, Cassette Motor, Relay, Switches, Connectors

SCHEMATIC DIAGRAM (AUDIO SECTION)

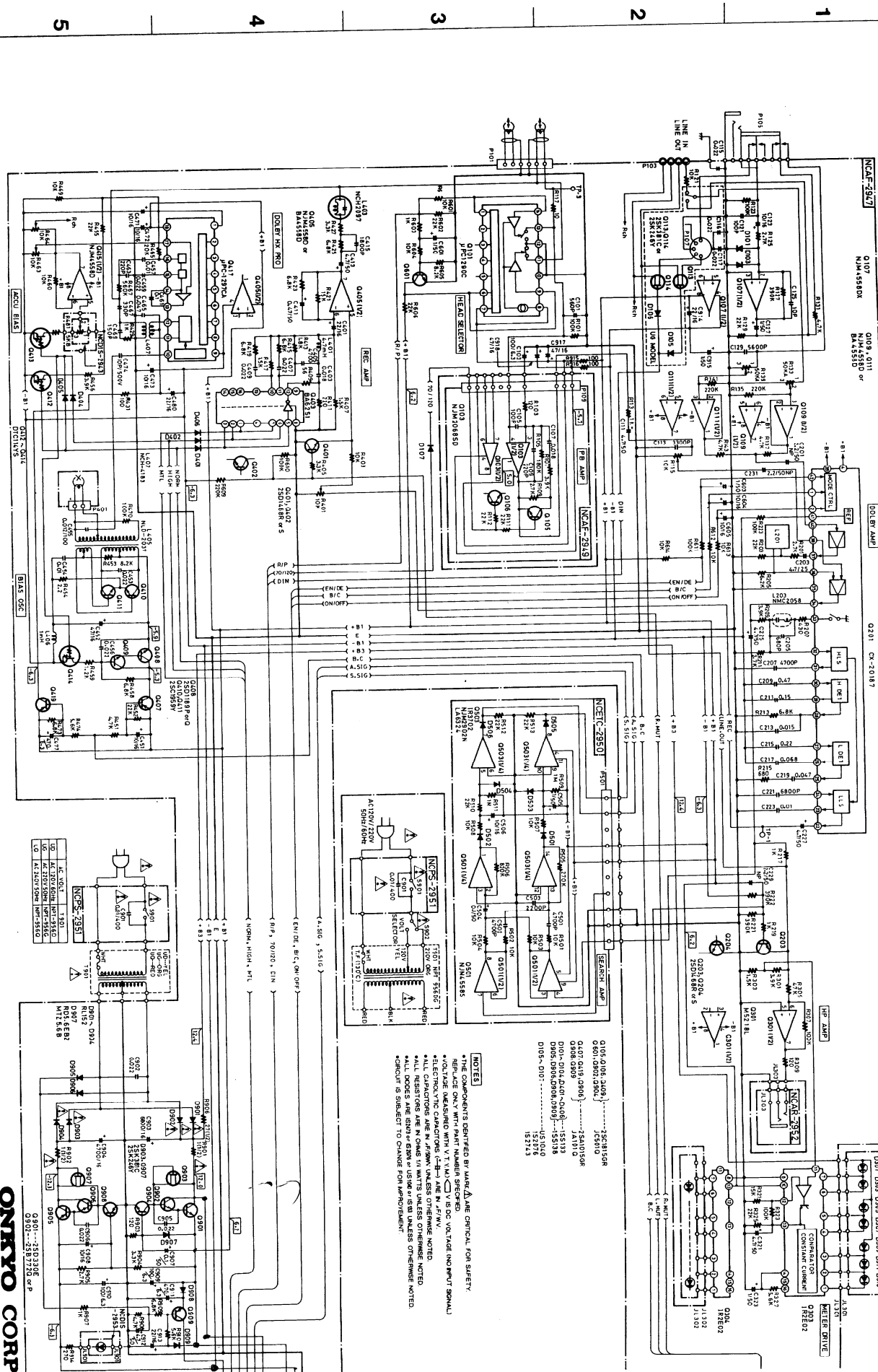

A B C D E F G

- 0105 0108 2A08 5C8181508
 0101 0205 0206 JCS910
 0107 0419 0906 25A01056
 0308 0309 1A1010
 0104 0104 0104 0104 155138
 0101 0101 0101 0101 155138
 0103 0103 0103 0103 155106
 0103 0103 152716
 152716

NOTES

- *THE COMPONENTS IDENTIFIED BY MARK Δ ARE CRITICAL FOR SAFETY.
- REPLACE ONLY WITH PART NUMBER SPECIFIED.
- *OUTPUT (MEASURED WITH V.T.M.) IS IN D.C. VOLTAGE (NO W.P. SIGNAL).
- *ELECTRICAL CHARACTERISTICS ARE IN P.P.M. UNLESS OTHERWISE NOTED.
- *ALL RESISTORS ARE IN OHMS UNLESS OTHERWISE NOTED.
- *ALL DIODES ARE IN OHMS UNLESS OTHERWISE NOTED.
- *SIGNAL IS SUBJECT TO CHANGE FOR IMPROVEMENT.

A B C D E F G

TAPE MECHANISM-EXPLODED VIEW

